

AD-A172 689

ENVIRONMENTAL IMPACT RESEARCH PROGRAM RANGELAND DRILL
SECTION 843 US ARMY (U) ARMY ENGINEER WATERWAYS
EXPRIMENT STATION VICKSBURG MS ENVIR T B DOERR
JUL 86 WES/TR/EL-86-41 F/G 2/4

1/1

UNCLASSIFIED

NL



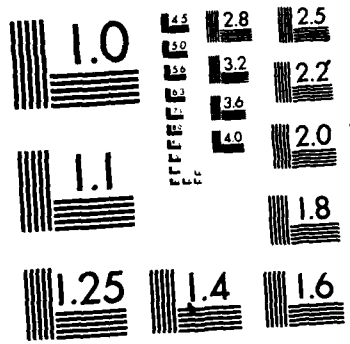

MICROCOPY RESOLUTION TEST CHART
NATIONAL BUREAU OF STANDARDS-1963-A



US Army Corps of Engineers

AD-A172 689

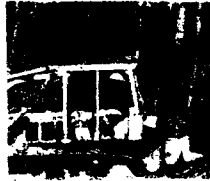

DTIC FILE COPY

ENVIRONMENTAL IMPACT RESEARCH PROGRAM

TECHNICAL REPORT EL-86-41

RANGELAND DRILL

Section 8.4.3, US ARMY CORPS OF ENGINEERS WILDLIFE RESOURCES MANAGEMENT MANUAL

by

Ted B. Doerr

Environmental Laboratory

DEPARTMENT OF THE ARMY Waterways Experiment Station, Corps of Engineers PO Box 631, Vicksburg, Mississippi 39180-0631

DTIC ELECTE

OCT 3 1986

S [Handwritten signature]

B



July 1986

Final Report

Approved For Public Release. Distribution Unlimited

Prepared for DEPARTMENT OF THE ARMY US Army Corps of Engineers Washington, DC 20314-1000

Under EIRP Work Unit 31631

411388 p1m 86 10 01 167

12

861001160

Unclassified

AD-A172689

SECURITY CLASSIFICATION OF THIS PAGE

Form Approved
OMB No 0704-0188
Exp Date Jun 30 1986

REPORT DOCUMENTATION PAGE			
1a REPORT SECURITY CLASSIFICATION Unclassified		1b RESTRICTIVE MARKINGS	
2a SECURITY CLASSIFICATION AUTHORITY		3 DISTRIBUTION / AVAILABILITY OF REPORT Approved for public release; distribution unlimited.	
2b DECLASSIFICATION / DOWNGRADING SCHEDULE			
4 PERFORMING ORGANIZATION REPORT NUMBER(S) Technical Report EL-86-41		5 MONITORING ORGANIZATION REPORT NUMBER(S)	
6a NAME OF PERFORMING ORGANIZATION USAEWES Environmental Laboratory	6b OFFICE SYMBOL (if applicable)	7a NAME OF MONITORING ORGANIZATION	
6c ADDRESS (City, State, and ZIP Code) PO Box 631 Vicksburg MS 39180-0631		7b ADDRESS (City, State, and ZIP Code)	
8a NAME OF FUNDING / SPONSORING ORGANIZATION US Army Corps of Engineers	8b OFFICE SYMBOL (if applicable)	9 PROCUREMENT INSTRUMENT IDENTIFICATION NUMBER	
8c ADDRESS (City, State, and ZIP Code) Washington, DC 20314-1000		10 SOURCE OF FUNDING NUMBERS	
		PROGRAM ELEMENT NO	PROJECT NO
		TASK NO	WORK UNIT ACCESSION NO
			EIRP 31631
11 TITLE (Include Security Classification) Rangeland Drill: Section 8.4.3, US Army Corps of Engineers Wildlife Resources Management Manual			
12 PERSONAL AUTHOR(S) Doerr, Ted B.			
13a TYPE OF REPORT Final report	13b TIME COVERED FROM _____ TO _____	14 DATE OF REPORT (Year, Month, Day) July 1986	15 PAGE COUNT 11
16 SUPPLEMENTARY NOTATION Available from National Technical Information Service, 5285 Port Royal Road, Springfield, VA 22161.			
17 COSATI CODES		18 SUBJECT TERMS (Continue on reverse if necessary and identify by block number)	
FIELD	GROUP	SUB-GROUP	
			Rangeland drill
			Drill Seeders
			Equipment
			Range restoration
			Reclamation
			Planting methods
19 ABSTRACT (Continue on reverse if necessary and identify by block number)			
<p>An equipment report on the rangeland drill is provided as Section 8.4.3 of the US Army Corps of Engineers Wildlife Resources Management Manual. The report is designed to assist the Corps District or project biologist with the selection and use of types of equipment and materials available for habitat development and manipulation. Topics covered include description, operation and maintenance, limitations, and availability.</p> <p>The rangeland drill is a heavy-duty, side-wheel drill developed for seeding rough terrain in semiarid regions. Management objectives for using the rangeland drill are stated, and benefits to wildlife habitat are discussed. The design and assembly of equipment are described and illustrated, and general specifications are provided. Methods of operation are described, and maintenance and safety requirements are given. Appropriate cautions and limitations are discussed.</p>			
20 DISTRIBUTION / AVAILABILITY OF ABSTRACT <input checked="" type="checkbox"/> UNCLASSIFIED UNLIMITED <input type="checkbox"/> SAME AS RPT <input type="checkbox"/> DTIC USERS		21 ABSTRACT SECURITY CLASSIFICATION Unclassified	
22a NAME OF RESPONSIBLE INDIVIDUAL		22b TELEPHONE (Include Area Code)	22c OFFICE SYMBOL

PREFACE

This work was sponsored by the Office, Chief of Engineers (OCE), US Army, as part of the Environmental Impact Research Program (EIRP), Work Unit 31631, entitled Management of Corps Lands for Wildlife Resource Improvement. The Technical Monitors for the study were Dr. John Bushman and Mr. Earl Eiker, OCE, and Mr. Dave Mathis, Water Resources Support Center.

This report was prepared by Mr. Ted B. Doerr, Range Science Department, Colorado State University, Fort Collins, Colo. Mr. Doerr was employed by the Environmental Laboratory (EL), US Army Engineer Waterways Experiment Station (WES), under an Intergovernmental Personnel Act contract with Colorado State University during the period this report was prepared. Mr. Chester O. Martin, Team Leader, Wildlife Resources Team, Wetlands and Terrestrial Habitat Group (WTHG), EL, was principal investigator for the work unit. Information and specifications on equipment were provided by Mr. Dan W. McKenzie, USDA Forest Service, Equipment Development Center, San Dimas, Calif., and Mr. David B. McMIndes, Colorado Yampa Coal Company, Yampa, Colo. Review and comments were provided by Mr. Martin, WES, and Mr. Larry E. Marcy, Texas A&M University.

The report was prepared under the general supervision of Dr. Hanley K. Smith, Chief, WTHG, EL; Dr. Conrad J. Kirby, Chief, Environmental Resources Division, EL; and Dr. John Harrison, Chief, EL. Dr. Roger T. Saucier, WES, was Program Manager, EIRP. The report was edited by Ms. Jessica S. Ruff of the WES Publications and Graphic Arts Division (PGAD). Drawings were prepared by Mr. John R. Harris, Scientific Illustrations Section, PGAD, under the supervision of Mr. Aubrey W. Stephens, Jr.

COL Allen F. Grum, USA, was the previous Director of WES. COL Dwayne G. Lee, CE, is the present Commander and Director. Dr. Robert W. Whalin is Technical Director.

This report should be cited as follows:

Doerr, Ted B. 1986. "Rangeland Drill: Section 8.4.3, US Army Corps of Engineers Wildlife Resources Management Manual," Technical Report EL-86-41, US Army Engineer Waterways Experiment Station, Vicksburg, Miss.

NOTE TO READER

This report is designated as Section 8.4.3 in Chapter 8 -- EQUIPMENT, Part 8.4 -- DRILL AND BROADCAST SEEDERS, of the US ARMY CORPS OF ENGINEERS WILDLIFE RESOURCES MANAGEMENT MANUAL. Each section of the manual is published as a separate Technical Report but is designed for use as a unit of the manual. For best retrieval, this report should be filed according to section number within Chapter 8.



Accession For	
NTIS GRA&I	<input checked="" type="checkbox"/>
DTIC TAB	<input type="checkbox"/>
Unannounced	<input type="checkbox"/>
Justification	
By	
Distribution/	
Availability Codes	
Availability	
Dist	Special
A1	

RANGELAND DRILL

Section 8.4.3, US ARMY CORPS OF ENGINEERS
WILDLIFE RESOURCES MANAGEMENT MANUAL

DESCRIPTION	3	LIMITATIONS	7
OPERATION	6	AVAILABILITY	7
MAINTENANCE	6	LITERATURE CITED	8

The rangeland drill is a heavy-duty, side-wheel drill developed for seeding rough terrain in semiarid regions. The drill is better adapted to rocky sites and hard soils than conventional grain drills and can be used with or without previous site preparation. The rangeland drill can also be used as a deep-furrow drill to break up compaction and is adapted to mine spoil seeding. It has the capacity to control small brush and annuals and is often used in areas that have been burned or chemically treated (Brown 1977, Larson 1980). The drill has been used mainly in the West and Midwest to establish vegetation for erosion control and "special-use" pastures. It has also been used extensively to improve range sites for wildlife and livestock production.

DESCRIPTION

The rangeland drill features large wheels, a high-clearance reinforced frame, and single-disk openers independently suspended on trailing arms (Fig. 1). Specifications for full-sized and half-sized models are given in Table 1. Ten single-disk furrow openers can be spaced 1 to 1.5 ft apart, and disks have depth control band settings of 14, 16, 18, and 20 in. to ensure proper seeding depth (Brown 1977, Larson 1980). Seeder arms are protected from rocks and brush by skid plates, and drag chains or pipe drags are pulled behind the seeder arms to bury seed in furrows. Each disk is independently hinged to go over obstacles without bearing the weight of the drill, thereby reducing breakdowns. A brush guard in front of the seeder and steel plating around the gear train also reduce breakdowns (Vallentine 1971).

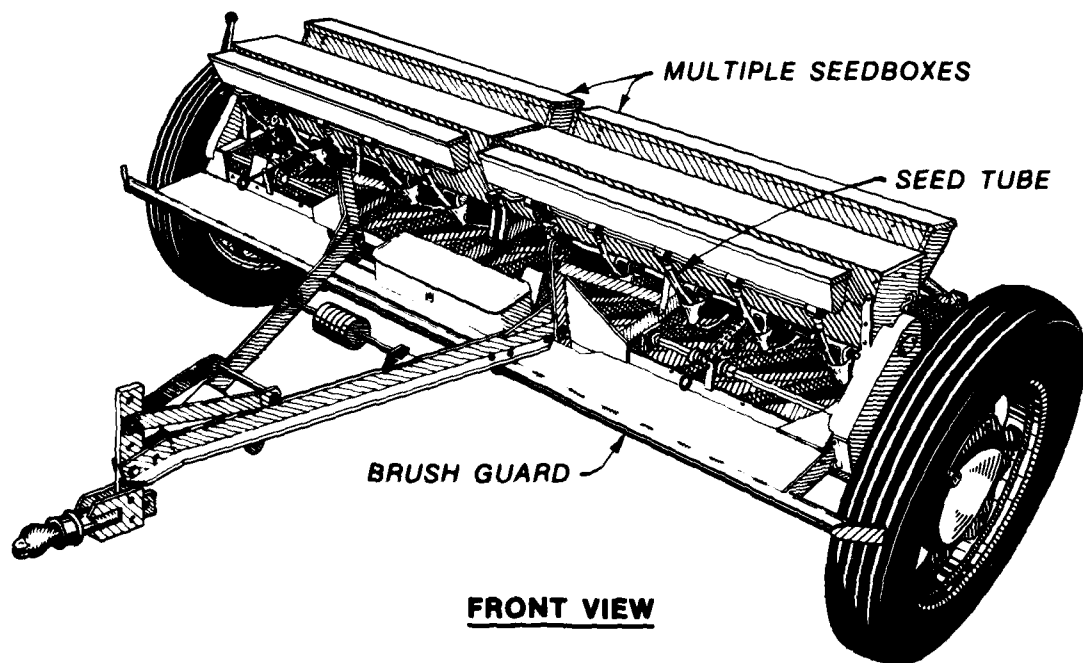

FRONT VIEW

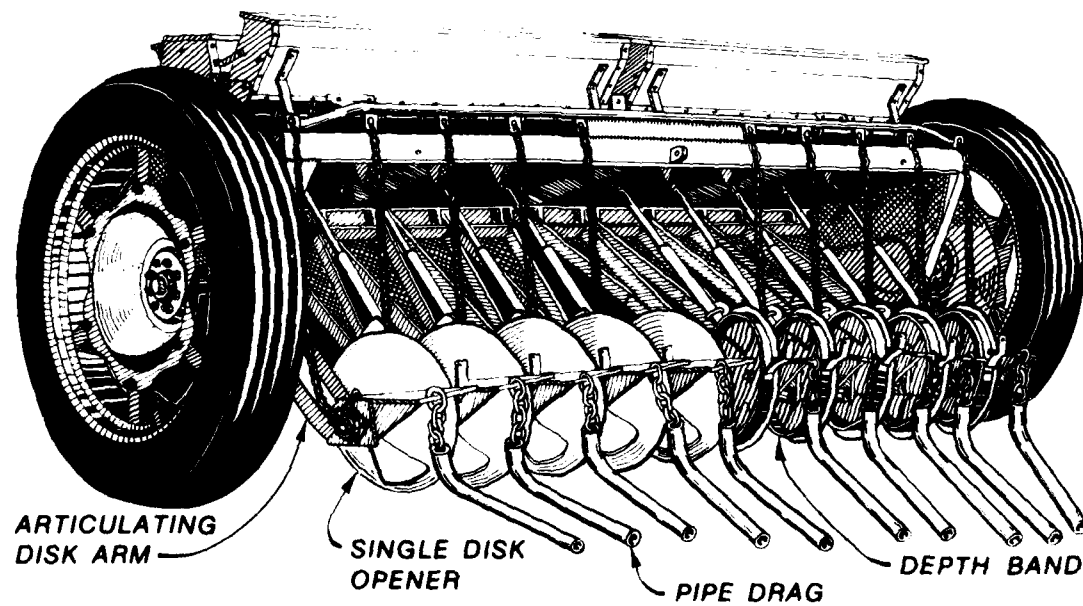

REAR VIEW

Figure 1. Front and rear views of the rangeland drill, showing major features (after USDA Forest Service 1967)

Table 1. Specifications for rangeland drills*

Feature	Full-sized Model
Furrow opener mechanism	Single disk
Furrow depth	2, 4, or 6 in.
Furrow spacing	12 or 18 in.
Furrow cover mechanism	Drag chains or pipe harrows
Number of furrows created	10; 5 for half-sized model
Seedbox types	Legume; grass seed
Seedbox capacity	13-36 cu ft
Seedbox agitators	Paddle or auger
Overall width	13.5 ft; 8.5 ft for half-sized model
Power requirements	
Single drill	40-45 hp
Dual drills	65 hp
Area seeded/hour	2.5-5.0 ac/hr
Optimum seeding speed	3.5-4 mph

* Specifications pertain to both full- and half-sized models except where noted.

Drills can be equipped for deep-furrow drilling with special furrowing arms and heavy-duty 24-in. disks. The disk angles can be adjusted on the arms to better control small brush and annuals in the furrows. Furrow depth can be controlled with the depth bands or by adding weights to the trailing arms; pipe drags are attached to pack soil during deep-furrow drilling operations. Other implements available for the drill include (1) a small-seed hopper attachment, (2) a fertilizer attachment, (3) a brush guard to protect the running gear, and (4) steel wheels for use on sites with extensive brush snags where rubber tires cannot function properly (Larson 1980). The drill can be modified for reduced seeding rates and large-scale chemical application. Half-size, or 5-ft, models are also available with 5 single-disk furrow openers (Larson 1980).

Rangeland drills are equipped with 1 or 2 seedboxes. The standard seedbox is best adapted for seeding only 1 species, or several species when the seeds are equivalent in weight and size, such as a mixture of cool-season

grass seed. A second legume seedbox is used to meter smaller, heavy legume seeds separately from grass seed. Seed agitators in the seedbox (that ensure even mixing of the species) and seed-metering apparatus are mechanically powered by the wheel axle. As with other seed drills, the rangeland drill accurately meters the amount of seed at the proper planting depth and ensures good soil-seed contact. Poor "fluffy" seed metering was a problem with original rangeland drill seedboxes; however, a seedbox has been modified to provide more accurate metering and placement of fluffy seed using a special agitator, redesigned picker wheel, semicircular seedbox, and oversized seed tubes (Wiedemann et al. 1980, Wiedeman and Cross 1981).

OPERATION

Drills can be pulled singly or in sets of 2 or 3 using multiple hitch attachments. However, there is a loss of maneuverability and a greater power requirement when additional drills are used simultaneously (Larson 1980). Single drills should be pulled by a 45-hp tractor; double and triple drills should be pulled by 65- and 90-hp tractors, respectively. Tractors should not be driven at speeds in excess of 4 mph to minimize breakdowns and ensure good seed placement, and drills should be operated on the contour on slopes no greater than 3:1. Operators can seed 2.5 to 5.0 acres/hour using rubber-tired drills (Larson 1980).

One person is sufficient to operate the drill, but 2 people will allow smoother operation. The second person can increase efficiency by making sure that seeder arms are free of debris, disks are not broken, and seed is being metered accurately. No specific safety requirements are necessary, but trained personnel should be in charge to ensure proper usage of equipment. No repairs should be undertaken while equipment is in motion, and hands and tools should be clear of all mechanical apparatus when in use.

MAINTENANCE

The rangeland drill does not require special storage conditions or maintenance. Periodic lubrication and inspection of fittings for tightness and excessive wear are usually sufficient. Spot welding will have to be performed as old welds break and as metal fatigue occurs.

LIMITATIONS

The rangeland drill has few limitations when used on moderate slopes and pulled by a small tractor. Large tractors should not be used to pull single drills because excessive horsepower is responsible for more damage than any other factor (Brown 1977). The drill must not be operated on slopes too steep for contour furrowing (greater than 18%). Seeding can be accomplished on wet soils, but it is not recommended. Seeders become easily plugged with dirt, which increases the amount of time required for seeding and reduces the efficiency of vegetation establishment.

AVAILABILITY

The rangeland drill is available from the following company:

Laird Welding and Manufacturing Works
Box 1053
531 S. Highway 59
Merced, California 95340

LITERATURE CITED

- Brown, D. 1977. Equipment for reclaiming strip mined land. USDA For. Serv. Equipment Development Center, Catalogue No. 7728 2503. 58 pp.
- Larson, J. E. 1980. Revegetation equipment catalogue. USDA For. Serv. Equipment Development Center, Catalogue No. 8042 2501. 198 pp.
- USDA Forest Service. 1967. Service and parts manual for the rangeland drill - models PD-10X6 & B-20-6. USDA For. Serv. Equipment Development Center. San Dimas, Calif. 77 pp.
- Vallentine, J. F. 1971. Range Development and Improvements. Brigham Young Univ. Press, Provo, Utah. 516 pp.
- Wiedemann, H. T., J. H. Brock, C. E. Fisher, and B. T. Cross. 1980. Seed metering and placement devices for rangeland seeder. Trans. Am. Soc. Agric. Eng. 22:972-977.
- _____, and B. T. Cross. 1981. Rangeland seeder development using semi-circular seedbox and auger agitation seed metering concept. J. Range Manage. 34:340-342.

END

11-86

DT/C