

MICROCOPY RESOLUTION TEST CHART  
NATIONAL BUREAU OF STANDARDS 1963-A

CLASSIFIED  
SECURITY CLASSIFICATION

2

AD-A173 183

ITATION PAGE

1a. REPORT SECURITY CLASSIFICATION  
Unclassified

b. RESTRICTIVE MARKINGS

2a. SECURITY CLASSIFICATION AUTHORITY  
SELECTED

3. DISTRIBUTION/AVAILABILITY OF REPORT  
Approved for public release;  
distribution unlimited.

2b. DECLASSIFICATION/DOWNGRADING SCHEDULE  
OCT 17 1986

4. PERFORMING ORGANIZATION REPORT NUMBER(S)  
D9

5. MONITORING ORGANIZATION REPORT NUMBER(S)  
AFOSR-TR. 85-0809

6a. NAME OF PERFORMING ORGANIZATION  
University of New Mexico

6b. OFFICE SYMBOL  
(If applicable)

7a. NAME OF MONITORING ORGANIZATION  
AFOSR

6c. ADDRESS (City, State and ZIP Code)  
Center for Advanced Studies  
800 Yale Blvd. NE  
Albuquerque, NM 87131

7b. ADDRESS (City, State and ZIP Code)  
Building 410  
Bolling AFB, D.C. 20332-6448

8a. NAME OF FUNDING/SPONSORING ORGANIZATION  
AFOSR

8b. OFFICE SYMBOL  
(If applicable)  
NP

9. PROCUREMENT INSTRUMENT IDENTIFICATION NUMBER  
AFOSR-85-0109

8c. ADDRESS (City, State and ZIP Code)  
Building 410  
Bolling AFB, D.C. 20332-6448

10. SOURCE OF FUNDING NOS.  
PROGRAM ELEMENT NO. PROJECT NO. TASK NO. WORK UNIT NO.  
61102F 2301 A8

11. TITLE (Include Security Classification)  
"THE CORRELATED EMISSIONS LASER GYROSCOPES AND G-WAVE DETECTORS", Unclassified

10. LASER - TOWARDS HIGH SENSITIVITY RING

12. PERSONAL AUTHOR(S)  
Dr's M. O. Scully & L. M. Pedrotti

13a. TYPE OF REPORT  
FINAL

13b. TIME COVERED  
FROM 85/03/01 TO 86/05/31

14. DATE OF REPORT (Yr., Mo., Day)  
September, 1986

15. PAGE COUNT  
114

16. SUPPLEMENTARY NOTATION

17. COSATI CODES		
FIELD	GROUP	SUB. GR.

18. SUBJECT TERMS (Continue on reverse if necessary and identify by block number)

19. ABSTRACT (Continue on reverse if necessary and identify by block number)

In addition to this fundamental research in the nature of the noise present in a measurement of phase, and the consequent development of the CEL concept, we have carried out research in a number of related topics. This includes acting as a theoretical support group for (now defunct) large, passive, resonant-ring gyroscope experimental effort which was carried out at F. J. Seiler laboratories at the Air Force Academy. In addition, a preliminary experimental RLG effort has begun at the University of New Mexico under the auspices of this contract. Finally, we studied in a somewhat general manner the quantum distribution functions. Techniques involved in this latter study are very useful in calculations of quantum noise. (See for example attached preprint B).

OTIC FILE COPY

20. DISTRIBUTION/AVAILABILITY OF ABSTRACT  
UNCLASSIFIED/UNLIMITED  SAME AS RPT.  DTIC USERS

21. ABSTRACT SECURITY CLASSIFICATION  
UNCLASSIFIED

22a. NAME OF RESPONSIBLE INDIVIDUAL  
Dr. Robert J. Barker

22b. TELEPHONE NUMBER  
(Include Area Code)  
202(767-5011)

22c. OFFICE SYMBOL  
NP

**AFOSR-TR. 86-0899**

Final Scientific Report for the AFOSR-85-0109 Contract:  
**THE CORRELATED EMISSION LASER - TOWARDS HIGH SENSITIVITY  
RING LASER GYROSCOPES AND G-WAVE DETECTORS**

by

M. O. Scully and L. M. Pedrotti

Center for Advanced Studies and  
Dept. of Physics and Astronomy  
University of New Mexico  
Albuquerque, NM 87131

and

Max-Planck-Institute fur Quantenoptik  
D-8046 Garching bei Munchen  
West Germany

Approved for public release;  
distribution unlimited.

September, 1986

AIR FORCE OFFICE OF SCIENTIFIC RESEARCH (AFSC)  
NOTICE OF TRANSMITTAL TO DTIC  
This technical report has been reviewed and is  
approved for public release IAW AFR 190-12.  
Distribution is unlimited.  
MATTHEW J. KETTER  
Chief, Technical Information Division

**86 10 6 064**

## TABLE OF CONTENTS

- I. INTRODUCTION
- II. CONVENTIONAL QUANTUM LIMITS TO RLG SENSITIVITY
- III. TESTS OF GENERAL RELATIVITY
- IV. THEORY OF CORRELATED SPONTANEOUS EMISSION LASERS
- V. CEL G-WAVE DETECTOR
- VI. RELATED RESEARCH
- VII. SUMMARY
  - A. Quantum-Limited Sensitivity
  - B. Related Topics

Accession For	
NTIS CRA&I	<input checked="" type="checkbox"/>
DTIC TAB	<input type="checkbox"/>
Unannounced	<input type="checkbox"/>
Justification	
By	
Distribution/	
Availability Codes	
Dist	Avail and/or Special
A-1	

## I. INTRODUCTION

In this final scientific report we summarize the research completed under AFOSR contract number 85-0109. The general area of research involved finding a means to improve the quantum limit sensitivities of ring laser gyroscopes (RLG'S) for use as rotation sensors.

A ring gyro sensitive to rotation rates  $10^{-10}$  times that of the rotation rate of the earth ( $\Omega_E$ ) would revolutionize experimental general relativity, since it would be sensitive to a class of effects which have yet to be detected. In particular, such an RLG could detect the so-called Lense-Thirring effect (sometimes called magnetic gravity). This effect has never been seen, and alternate detection schemes involve launching a mechanical gyroscope into orbit. A detection scheme involving a RLG has the great advantage that it could be used on the surface of the earth. This is because environmental noise tends to cancel in the output of an RLG, since this output involves heterodyning two beams which have counterpropagated around a ring cavity. Thus, the noise tends to influence both modes in the same way and so cancels in the heterodyne output. In addition to probing metric gravity, such an ultrasensitive RLG would push the measurement of many geophysical effects (such as measurement of earth rate, azimuth sensing, and seismic disturbances) into a new regime of precision.

In the most promising variant of the RLG (the active scheme) the limiting noise source is due to diffusion in the relative phase between the two counterpropagating laser modes. This phase diffusion results from independent spontaneous emission events into the two laser modes. These events add to the individual modes with random phase and hence cause a diffusion of the relative phase. We have developed a means to completely quench noise due to spontaneous emission in the relative phase between two different modes. This can be done

in a new type of laser which we call the correlated spontaneous emission laser (CEL). The concept is completely, new and we believe that it can be used to improve the ultimate ability to measure the relative phase between two laser fields such as is needed in RLG's and gravity-wave detection.

In this report we describe the CEL concept (more detail is found in reprints A-C attached to this report) and show how it may be used to increase the ultimate sensitivity of gravity-wave detectors (GWD's). We believe that a very similar scheme (indeed, we are currently developing just such a scheme) can be used to improve the ultimate sensitivities of RLG's.

In addition to this fundamental research on the nature of the noise present in a measurement of phase, and the consequent development of the CEL concept, we have carried out research in a number of related topics. This includes acting as a theoretical support group for the (now defunct) large, passive, resonant-ring gyroscope experimental effort which was carried out at F. J. Seiler laboratories at the Air Force Academy. In addition, a preliminary experimental RLG effort was begun at the University of New Mexico under the auspices of this contract. Finally, we studied in a somewhat general manner the quantum distribution functions. Techniques involved in this latter study are very useful in calculations of quantum noise. (See for example attached preprint B).

This report is organized in the following manner. In Section II we review the quantum noise limitations to conventional RLG schemes. We show in Section III that these schemes are not as yet, with current state-of-the-art technology, sensitive enough to probe the nature of metric gravity. In Section IV we introduce the CEL concept, and in Section V show how the CEL can be incorporated into a differential length-measuring device (the GWD) in such a way as to improve the sensitivity of this device. Finally, in Section VI we

describe the research done in related areas.

## II. CONVENTIONAL QUANTUM LIMITS TO RLG SENSITIVITY

In this section we briefly review the operating principles of the RLG and derive the quantum noise limits associated with two standard schemes. Comparing the limits obtained in this way to the sensitivities necessary for probing metric gravity (and improving geophysical measurements) allows us to derive the technological requirements which the standard RLG schemes must meet if they are to be useful in this regard. We conclude that these requirements are beyond what is possible with present, state-of-the-art, techniques. This is intended as motivation for considering the novel CEL concept to be discussed later in this report.

There are essentially two standard RLG schemes. We call these the passive and active schemes and depict prototypes of these in Fig's 1 and 2.

Both devices are based upon the Sagnac effect. The Sagnac effect is the splitting between the effective round-trip path lengths in the two directions around a rotating ring cavity. It has been shown that this path length difference can be expressed as

$$\Delta L = L^+ - L^- = \frac{4A\Omega}{c} , \quad (1a)$$

where  $\Omega$  is the rotation rate of the ring,  $A$  the area enclosed by the light path,  $c$  the speed of light,  $L^+$  the round-trip path length in the same direction as the ring's rotation and  $L^-$  the path length in the opposite direction. The active and passive schemes differ in how they utilize the Sagnac effect. Note that in the detection of gravity waves (to which we have successfully applied the CEL concept) the g-wave imposes a differential length in the two arms of an interferometer (see Fig. 3) given by

$$\Delta L = \frac{h(t)}{2} L_0 \quad (1b)$$

where  $L_0$  is the length of each arm of the interferometer in the absence of the gravity wave and  $h(t)$  is the time-dependent amplitude which characterizes the strength of the g-wave. Typically the magnitude of  $h(t)$  at the surface of the earth due to astronomical sources of g-waves is  $\sim 10^{-21}$ . Equations (1a) and (1b) emphasize the great similarity between RLG's and GWD's. Both are concerned with measurements of extremely small length changes by optical means. In the passive RLG the phase shift associated with the difference in path length is measured by noting the phase shift between two portions of an external beam which is split and counterpropagated around a passive ring cavity see Fig. 1 and then recombined on a photodetector. This phase shift is given by

$$\phi_p = \frac{\Delta L}{\lambda} = \frac{4A}{\lambda c} \Omega \quad (2)$$

where  $\lambda$  is the reduced wavelength of the laser light. In a situation where the light is bounced around the ring many times before it exits (such as when using a fiber coil as the cavity or a Fabry-Perot type of device) the phase shift given by Eq. (2) is enhanced as

$$\phi_p = \frac{c}{\gamma P} \frac{4A}{\lambda c} \Omega = \frac{4A}{\lambda P} \frac{1}{\gamma} \Omega \equiv \frac{S}{\gamma} \Omega \quad (3)$$

where  $P$  is the perimeter of the ring path and  $\gamma$  is the loss rate of the cavity (thus  $c/P\gamma$  is just the number of bounces an average photon makes before it exits the ring to be detected). In Eq. 3 we have made the common replacement  $S = 4A/\lambda P$ .

In the active device [Fig. 2] a lasing medium is placed inside the ring cavity. Thus, the lasing frequency into the two directions around the ring is

determined by the respective round trip cavity lengths. That is, the lasing frequencies,  $\nu^+$  and  $\nu^-$ , of the two counterpropagating laser modes are given by

$$\nu^\pm = \frac{n\pi c}{L^\pm} \quad . \quad (4)$$

The frequency difference is then given by

$$\Delta\nu = \nu^- - \nu^+ = n\pi c \left( \frac{1}{L^-} - \frac{1}{L^+} \right) \approx \nu^0 \frac{\Delta L}{P} \quad , \quad (5)$$

where  $\nu^0$  is the (degenerate) lasing frequency in the absence of rotation (i.e. when  $\Delta L = 0$ ) and  $P$  is the physical perimeter of the ring. Using Eq. 1 in Eq. 5 yields the well known result

$$\Delta\nu = \frac{4A}{\lambda P} \Omega = S\Omega \quad . \quad (6)$$

It is convenient to re-express Eq. 6 as the phase shift accumulated in a measurement time  $\tau_m$ , so that it can be compared to the phase shift generated in a passive scheme. That is, the active phase shift is given by

$$\phi_a = S\tau_m\Omega \quad . \quad (7)$$

Comparison with the passive phase shift (Eq. 3) shows that the active phase difference signal is larger than the passive one so long as the measurement time  $\tau_m$  is longer than the inverse of the cavity decay rate  $\gamma^{-1}$ . The maximum measurement time is strictly limited only by the period (or duration) of the disturbance which causes the rotation rate  $\Omega$  of the ring to change. For the situations in which we are interested (probes of metric gravity, geophysical effects) this period is on the order of one day ( $\sim 10^5$  s). On the other hand, typical cavity ring-down times are  $\gamma^{-1} \sim 10^{-5}$  seconds. Thus we see that, under these conditions the active RLG generates a signal some  $10^{10}$  times larger than

a passive device of the same dimensions.

In determining the ultimate sensitivity of a device, however, signal strength is only half the story. The ultimate sensitivity depends upon the signal to noise ratio. The limiting noise source in the passive device is so-called shot noise which can be attributed either to the statistical properties of the detection process or the intrinsic photon number uncertainty in a coherent electromagnetic field. In either case the uncertainty in a phase measurement due to shot noise has the well-known form

$$\delta\phi|_{\text{shot}} = \sqrt{\frac{h\nu}{P\tau_m}} \quad , \quad (8)$$

where  $P$  is the laser output power,  $\tau_m$  the measurement time,  $\nu$  the lasing frequency, and  $h$  Planck's constant. Note that the factor inside the square root in Eq. 8 is essentially the inverse of the number of photons in the laser field. Equating this intrinsic noise to the passive signal and solving for  $\Omega$  yields the minimum rotation rate which can be reliably measured with a passive device. This procedure yields

$$\Omega_{\text{min}} = \frac{\gamma}{S} \sqrt{\frac{h\nu}{P\tau_m}} \quad . \quad \text{Passive Shot Noise Limit} \quad (9)$$

Note that the limit can be lowered by using cavities with lower losses, higher power, or larger scale factor (essentially longer perimeter). We will insert typical numbers into this formula after demonstrating that the active scheme, although it generates a much larger signal, also has an ultimate sensitivity limit of the same form as Eq. 9 because it suffers from a larger additional noise source due to spontaneous emission.

While the active device also exhibits an uncertainty due to shot noise, its largest intrinsic noise source is, by far, the independent spontaneous-

emission-induced phase drift of the two laser fields which counterpropagate around the active ring cavity. The counterpropagating fields in a passive device originate with a single external laser and hence any spontaneous emission-induced phase drift is common to both fields and cancels in a heterodyne measurement. However, in an active device lasing action occurs independently into the two directions around the ring and so the phases of these fields drift independently due to spontaneous emission. The uncertainty introduced into the relative phase is given by

$$\delta\phi = \sqrt{2D\tau_m} \quad \text{Spontaneous Emission Noise} \quad (10)$$

Here  $D$  is the characteristic diffusion rate of the phase of a laser field due to random spontaneous emission events. It is given by

$$D = \frac{\gamma}{2\bar{n}} = \frac{\gamma^2 h\nu}{2P} \quad , \quad (11)$$

where  $\bar{n}$  is the average number of photons in the laser cavity. Inserting Eq. (11) into Eq. (10) gives the limiting noise in an active RLG. That is,

$$\delta\phi = \gamma \sqrt{\frac{h\nu\tau_m}{P}} \quad \text{Spontaneous Emission Noise} \quad (12)$$

A more detailed account leading to Eq. (12) is given in the attached reprint C.

Equating the active signal and noise and solving for  $\gamma$  yields,

$$\gamma_{\min} = \frac{\gamma}{S} \sqrt{\frac{h\nu}{P\tau_m}} \quad \text{Active Spontaneous Emission Limit} \quad (13)$$

Comparison of the active and passive (Eq. 9) limits show that they are identical. In the passive scheme the signal is small but it only suffers from the relatively small shot noise. The active device has a much larger signal,

but this is accompanied by a larger noise source due to the independent drift of the phases of the counterpropagating gyro modes. This observation led us to develop the CEL, in which spontaneous emission noise in the relative phase between two laser fields can be quenched. Incorporating a CEL into a ring gyro scheme might, then, allow for a device with the large active signal and yet suffer only from the small intrinsic uncertainty due to shot noise. Such a device would clearly have a favorable sensitivity limit over both conventional active and passive schemes.

An argument precisely paralleling (see attached preprint D) the above RLG discussion can be carried out for GWD's by starting with the expression for the length difference due to a g-wave (Eq. (1b)), rather than that due to the Sagnac effect (Eq. (1a)). The result is a limit on the minimum detectable strength of g-wave which again applies to both active and passive devices.

That is,

$$h_{\min} = \frac{2\gamma}{v} \sqrt{\frac{h\nu}{P_{\text{in}}}} \quad , \quad \text{Conventional G-Wave Limit} \quad (14)$$

We show in Section V that incorporating a CEL into the active GWD scheme leads to a limit better than the conventional one given by Eq. (14).

### III. TESTS OF GENERAL RELATIVITY

The principal motivation for the development of ultra-sensitive RLG's is to probe metric gravity. It has been shown that a ring gyro on the surface of the earth should exhibit effective rotation rates due to purely general-relativistic effects. The frequency difference between the counter-running modes of a rotating gyroscope on the surface of the earth is

$$\Delta\nu = S[\omega_E + \omega_0 + \omega_{\text{mach}} + \omega_{\text{cosmos}} + \omega_{\text{curv}}] \quad . \quad (15)$$

The first two terms on the right hand side of Eq. (15) are due simply to the

rotation of the earth and the rotation of the gyro with respect to the earthbound laboratory. The last three terms are due to the curvature of spacetime.

The three gravitational contributions to the effective rotation rate of the ring can be viewed as follows. The term  $\Omega_{\text{mach}}$  is predicted to be nonzero by Einstein's theory whenever the gyro is near a massive rotating body (such as the earth or the sun.) This term describes the Lense-Thirring effect, and is said to be due to magnetic gravity, in analogy to the way in which a spinning electron has a magnetic moment. On the surface of the earth  $\Omega_{\text{mach}}$  is predicted to be on the order of  $10^{-10} \Omega_E$ . This term is of particular interest because no experimental evidence for "magnetic gravity" exists. The existence or absence of the second term  $\Omega_{\text{cosmos}}$  is a test for a preferred coordinate system in the universe. The existence of such a term would indicate the existence of a preferred frame. Einstein's theory does not have a preferred rest frame and so predicts that  $\Omega_{\text{cosmos}}$  should be zero. Other theories of metric gravity (such as that due to Ni) predict the existence of a preferred frame. A gyro sensitivity of  $10^{-10} \Omega_E$  would be necessary to push the experimental evidence for the absence of a preferred frame beyond the current limits set by lunar ranging experiments. The last term  $\Omega_{\text{curv}}$  is due to the static deformation of space by massive bodies near the gyro. Terms of this sort are predicted to give an effective rotation rate on the order of  $10^{-9} \Omega_E$ . It is evident that a RLG sensitive to rotation rates on the order of  $10^{-10} \Omega_E$  is necessary to be useful as a probe of metric gravity. This sensitivity is four orders of magnitude beyond the capability of any existing RLG.

The RLG test has one great advantage over other proposed probes of metric gravity which would be sensitive to the heretofore unseen magnetic gravity effects; the RLG device would be earthbound. Other proposed tests involve the

use of ordinary mechanical gyroscopes in orbiting satellites (to eliminate frictional noise).

Active ring laser gyros have been built by the aerospace industry which have sensitivities to  $10^{-6} \Omega_E$  in a 1000 second measurement time. These devices are essentially already at the quantum noise limit. No other devices have been built which approach this sensitivity. Further improvement depends upon bettering the technological state of the art. We can make an optimistic estimate of the best sensitivity which a conventional active RLG is likely to achieve in the next few years by inserting the following state-of-the-art parameters into Eq. 13. Consider a square cavity 10m on a side which utilizes 1 watt of stabilized He-Ne power. Let the decay rate of the cavity be  $10^5$  Hz and consider measurements times of 1000 seconds. These numbers lead to a minimum detectable rotation rate on the order of  $10^{-9} \Omega_E$ .

Thus, even under the most optimistic (and to some extent unrealistic) estimates an active RLG does not have the sensitivity required to act as a probe of metric gravity. There are two routes to improvement. One can either develop techniques which improve the state-of-the-art parameters employed above, or one can develop a novel scheme which has a favorable quantum noise limit. We choose the latter.

#### IV. THEORY OF CORRELATED SPONTANEOUS EMISSION LASERS

Here we summarize some of the results of the theory of CEL's obtained so far (attached preprints A-C). Clearly, in order to establish a correlation between the random spontaneous emission events which are responsible for phase diffusion, the two lasers considered must have a common gain medium. In addition to this, some applications (e.g., gravity-wave detection) require the two modes to oscillate in different cavities. One must then be able to separate them, which may be achieved if they have sufficiently different

frequencies (by using dichroic mirrors) or different polarizations (see Fig. 4. This leads one naturally to consider three-level schemes such as in Fig. 4, in which two different laser transitions share one common lower level. The two transitions may correspond to different frequencies as in Fig. 4 or polarizations or both.

Mutual coherence between the two modes will be achieved if one manages to excite the atoms into a coherent superposition of the two upper levels, i.e., a quantum-mechanical superposition of  $|a\rangle$  and  $|b\rangle$  in Fig. 1 with well-defined coefficients. Then the spontaneously emitted photons will of course have a random phase (since they are emitted at random times) but their projections on each of the two modes will have a well-defined relative phase (e.g.,  $\pi/2$ , if the two modes considered are two orthogonal linear polarizations and the spontaneous photons are circularly polarized). Such photons will not cause any diffusion of the relative phase of the two modes provided that the two modes already are oscillating with the right phase (and amplitude) relationship. In the examples we have studied, we obtain, in fact, a diffusion coefficient for the relative phase  $\psi$  given by

$$D(\psi) = \frac{1}{8} (\alpha_1/\rho_1^2 + \alpha_2/\rho_2^2 - \frac{\alpha_{12} + \alpha_{21}^*}{\rho_1\rho_2} e^{-i\psi}) + \text{c.c.} \quad (16)$$

where  $\alpha_1, \alpha_2$  are (amplitude gain coefficients (per unit time),  $\alpha_{12}$  and  $\alpha_{21}$  linear mode coupling coefficients arising from the coherent mixing of the atomic levels  $|a\rangle$  and  $|b\rangle$ ,  $\rho_1$  and  $\rho_2$  the (real) amplitudes of the two modes, (in units where  $\rho^2 =$  number of photons), and the angle  $\psi$  is defined in general as

$$\psi = (\nu_1 - \nu_2 - \nu_3)t + \phi_1 - \phi_2 - \phi_3 \quad (17)$$

Here  $\nu_1$  and  $\nu_2$  are the frequencies of the two modes, and  $\nu_3$  is the frequency of

an external field used to mix the atomic levels  $|a\rangle$  and  $|b\rangle$ . If the frequencies of the atomic transitions  $|a\rangle \rightarrow |c\rangle$  and  $|b\rangle \rightarrow |c\rangle$  are  $\omega_1$  and  $\omega_2$ , respectively, we require  $\nu_3 = \omega_1 - \omega_2$ , i.e., the external field (perhaps a microwave field) is resonant with the  $|a\rangle \rightarrow |b\rangle$  transition. (This is the scheme we refer to as the quantum-beat laser.) In the case where  $|a\rangle$  and  $|b\rangle$  are degenerate (Hanle-effect laser), the  $\nu_3$  term is absent from Eq. (17). In this case no external field is necessary, and atomic coherence is achieved by the pumping mechanism, which must prepare the atoms in a coherent superposition of  $|a\rangle$  and  $|b\rangle$ . Finally, the angle  $\phi$  in Eq. (17) is a constant that depends on the details of the coherent mixing/pumping mechanism.

In the cases we have investigated, it is possible to make  $\alpha_1 = \alpha_2 = \alpha_{12} = \alpha_{21} \equiv \alpha$ . Then, if things are arranged so that the two modes have the same amplitude ( $\rho_1 = \rho_2$ ), Eq. (15) gives

$$D(\psi) = \frac{\alpha}{2\bar{n}} (1 - \cos\psi) \quad , \quad (18)$$

where  $\bar{n}$  is the average number of photons in each mode. This is to be compared with Eq. (11) for ordinary laser operation. As mentioned above, this can be made zero when the two modes are oscillating with the right relative phase, i.e.,  $\psi = 0$ . Not surprisingly, such a configuration turns out to be preferred by the system, and the phase  $\psi$  is found to obey a mode-locking equation,

$$\dot{\psi} = -2\alpha \sin\psi \quad . \quad (19)$$

Now, Eqs. (18) and (19) show that the diffusion in the relative phase between two laser modes can indeed be made to vanish due to the CEL quenching of spontaneous emission noise. Note that this implies that  $\Delta\omega$  due to spontaneous emission (see Eq. (10)) vanishes.

The remaining question, then, is whether one can still extract some

information from the relative phase of the system, despite the fact that it tends to lock at the value  $\psi = 0$ .

#### V. CEL G-WAVE DETECTOR

In this section we show briefly how the CEL concept can be applied to an active g-wave detection scheme in order to improve the sensitivity of such a device beyond the standard limit given by Eq. (14). A much more detailed account of the system we envision is given in the attached reprint D.

Basically, we consider a system like the one shown in Fig. 4. A g-wave is taken to be incident from the left on the doubly resonant CEL cavity. This g-wave affects the length between mirrors  $M_0$  and  $M_3$  but leaves that between  $M_0$  and  $M_2$  unchanged. Thus, the resonant cavity frequency seen by the  $\nu_1$  lasing transition remains unchanged, but that seen by  $\nu_2$  is modified. This effective detuning changes the CEL mode-locking relation (Eq. (19) according to

$$\dot{\psi} = \frac{1}{2} \nu_1 h - \gamma \sin \psi \quad . \quad (20)$$

Here, we note that the intensity cavity loss rate  $\gamma$  is equal to twice the amplitude gain  $\alpha$  and  $\frac{1}{2} \nu_1 h$  is the detuning caused by the g-wave. (Recall that  $h$  is the dimensionless amplitude of the g-wave.) This locking equation has the steady state solution,

$$\psi_{ss} = \frac{\nu_1 h}{2\gamma} \quad , \quad (21)$$

so long as  $\nu_1 h \ll \gamma$ , which is always the case in practice. Using this in the expression for  $D(\psi)$  (Eq. (18)) and expanding the cosine leads to

$$D(\psi_{ss}) = \frac{\gamma}{4n} \left( \frac{\nu_1 h}{2\gamma} \right)^2 \quad , \quad (22)$$

which is much smaller than the diffusion coefficient for ordinary laser

operation given by Eq. (11). In fact, the limiting noise source becomes shot noise in this CEL case and the phase diffusion noise characterized by Eq. (22) can be ignored.

Thus, we have demonstrated that we can have effective noise quenching (Eq. (22)) and still retain a phase signal (Eq. (21)) proportional to the g-wave disturbance. However, considering shot noise (Eq. (8)) as the new limiting noise source, Eq. (21) leads to

$$h_{\min} = \frac{2\gamma}{\nu} \sqrt{\frac{\hbar\nu}{P\tau_m}} , \quad (23)$$

which is the conventional result given by Eq. (14). The problem is that the CEL coupling did eliminate spontaneous emission noise but at the same time it reduced the signal strength to essentially the same size as in a passive device. An active signal is given by Eq. (20) without the CEL locking term. This active signal phase is

$$\psi_a = \frac{1}{2} \nu_1 h \tau_m \gg \psi_{ss} = \frac{\nu_1 h}{2\gamma} . \quad (24)$$

How then can we retain the noise quenching and regain some of the active signal strength? The key can be found by examining Eqs. (20) and (21). Note that, if we could reduce the effective locking coefficient  $\gamma$  the steady-state value of the phase would be enhanced. We find that, by extracting some light from the mode with frequency  $\nu_1$  (by letting some light leak out of mirror  $M_2$  in Fig. 4 and injecting it with the right phase into the other mode (through mirror  $M_3$ ) and vice-versa, we can modify the locking equation to read

$$\psi = \frac{1}{2} \nu_1 h - (\gamma - R) \sin \psi , \quad (25)$$

where  $R$  is the rate at which light is extracted from one mode and coupled into

the other. This leads to a steady-state phase

$$\dot{\psi}_{ss} = \frac{v_1 h}{2(\gamma - R)} \quad , \quad (26)$$

which is clearly larger than the simple CEL scheme without the extra-cavity coupling. Phase diffusion is still negligible so that equating Eq. (26) to the shot noise phase error (Eq. (8) gives the favorable limit,

$$h_{\min}|_{\text{cel}} = \frac{2(\gamma - R)}{\nu} \sqrt{\frac{\hbar \nu}{P_{Tm}}} = \frac{\gamma - R}{\gamma} h_{\min}|_{\text{conventional}} \quad . \quad (27)$$

Just how small can we make this CEL enhancement factor,  $\gamma - R/\gamma$ ? In principle, the modified locking coefficient must be larger than the frequency  $\omega_g$  of the gravitational disturbance (we envision a sinusoidal  $g$ -wave of the form  $h(t) = h_0 \sin \omega_g t$ ), so that the system has time to lock to a steady-state phase value during one  $g$ -wave period and so insure noise quenching.

In this case,

$$h_{\min}|_{\text{cel}} = \frac{\omega_g}{\gamma} h_{\min}|_{\text{conventional}} \quad . \quad (28)$$

Now,  $\omega_g$  is typically 100 Hz and  $\gamma \sim 10^5$  Hz. Thus, we see that the CEL has a potential sensitivity some three orders of magnitude greater than conventional devices. (A more detailed analysis given in the attached preprint D shows that the enhancement factor  $\omega_g/\gamma$  should be replaced by  $\sqrt{\omega_g/\gamma}$  for the scheme we have proposed). This result is very interesting for several reasons. First it is interesting from a fundamental point of view. It shows that the fact that the conventional active and passive detection schemes have the same quantum limit does not mean that this limit cannot be bettered by a clever system such as the one we have developed. Second, this improvement by several orders of magnitude is not purely academic.  $G$ -wave detectors are rapidly approaching the state of

development where they will be quantum noise limited. The conventional quantum limit (with current technology) places them just on the verge of the sensitivity required to detect g-waves of the expected strength. Thus any reduction of the quantum noise limit may prove crucial to the eventual success of these detectors. Finally, we believe that a similar CEL scheme can be successfully applied to ring laser gyroscopes. In fact, we have carried out some preliminary research in this regard and find that the enhanced sensitivity of an RLG may be even larger (since the frequency associated with the general-relativistic effects which affect the gyro rotation rate are typically of order  $(24 \text{ hrs})^{-1} \sim 10^{-5} \text{ hz}$ , rather than the 100 Hz signal associated with g-waves).

#### VI. RELATED RESEARCH

In addition to the development of the CEL-RLG, we accomplished some research in related areas. One of us (L. Pedrotti) spent a summer at F. J. Seiler research labs at the Air Force Academy in Colorado Springs collaborating with the group there working on the (now defunct) large passive resonant ring gyroscope. Indeed, while this project was in existence, close collaboration existed between them and our group at the University of New Mexico. We advised them on the nature of the quantum noise limitations to their proposed device (which has the same form as the other conventional devices as given in the text by Eq. 9) and carried out several calculations involving the susceptibility of the large passive ring to environmental noise.

At the University of New Mexico some preliminary RLG experiments were setup towards research into novel RLG schemes involving the introduction of a nonlinear element into a ring cavity. Such a scheme had been suggested as a possible way to enhance the Sagnac effect by making the difference in the round-trip cavity lengths in the two directions around the ring depend

nonlinearly on the rotation rate of the ring. This preliminary experimental effort was intended to lay the necessary ground work for both independent RLG research at the University of New Mexico and as a means of supplementing the research effort at the F.J. Seiler laboratory.

Finally, in collaboration with Prof. Cohen of Hunter College, work was done involving generalizing the quantum distribution functions commonly used in quantum optics. An example of this research is attached as preprint E. While this work has no direct bearing on ring laser gyro physics, the techniques involved in handling the quantum distribution functions (such as Glauber's  $P(\alpha)$ ) are very useful in calculating expectation values of quantum noise operators. These sorts of calculations are one way to perform a rigorous quantum-mechanical treatment of the quantum limitations to the measurement of the relative phase between two laser fields (see preprint B). This of course has direct bearing on the ultimate sensitivity of ring laser gyroscopes.

## VII. SUMMARY

Here we summarize the major research contributions accomplished under this contract. We divide the work as follows:

### A. Quantum Limited Sensitivity

(1). We performed a thorough investigation of the quantum limits to conventional ring laser gyroscopes and gravitational wave detectors. We found that both active and passive devices have the same ultimate signal-to-noise ratio, even though the signal of an active device is much larger than that of a passive device of similar construction. The active scheme suffers from a large additional noise source due to spontaneous emission.

(2). We developed the correlated spontaneous emission laser with which it is possible to quench spontaneous emission noise in a measurement of the relative phase between two laser fields. This remarkable result

constitutes the major contribution performed under the auspices of this contract.

(3). We showed that the CEL concept can be incorporated into an active g-wave detection scheme with a better potential sensitivity than the conventional schemes. We anticipate that a similar scheme could be used to produce a ring laser gyroscope with a similarly enhanced sensitivity. Such an enhancement might make feasible an RLG probe of metric gravity.

#### B. Related Topics

(1). Theoretical support was provided to the large passive resonant-ring gyroscope effort at F. J. Seiler laboratory.

(2). A preliminary RLG experimental effort was initiated at the University of New Mexico.

(3). Research into the general nature of quantum distribution functions was done with future applications to better understanding the precise way in which quantum mechanics limits the precision with which measurements can be made.

We conclude by noting that the question of ultimate quantum noise limits is one of great fundamental and practical importance. If the sensitivities of g-wave detectors and RLG's could be improved (for instance by using the CEL) to the point where gravity waves and the Lense-Thirring effects could be detected, experimental astronomy and astrophysics would be revolutionized. In addition, this experimental evidence should provide great clarification of the consequences of general relativity and the nature of astrophysical events.

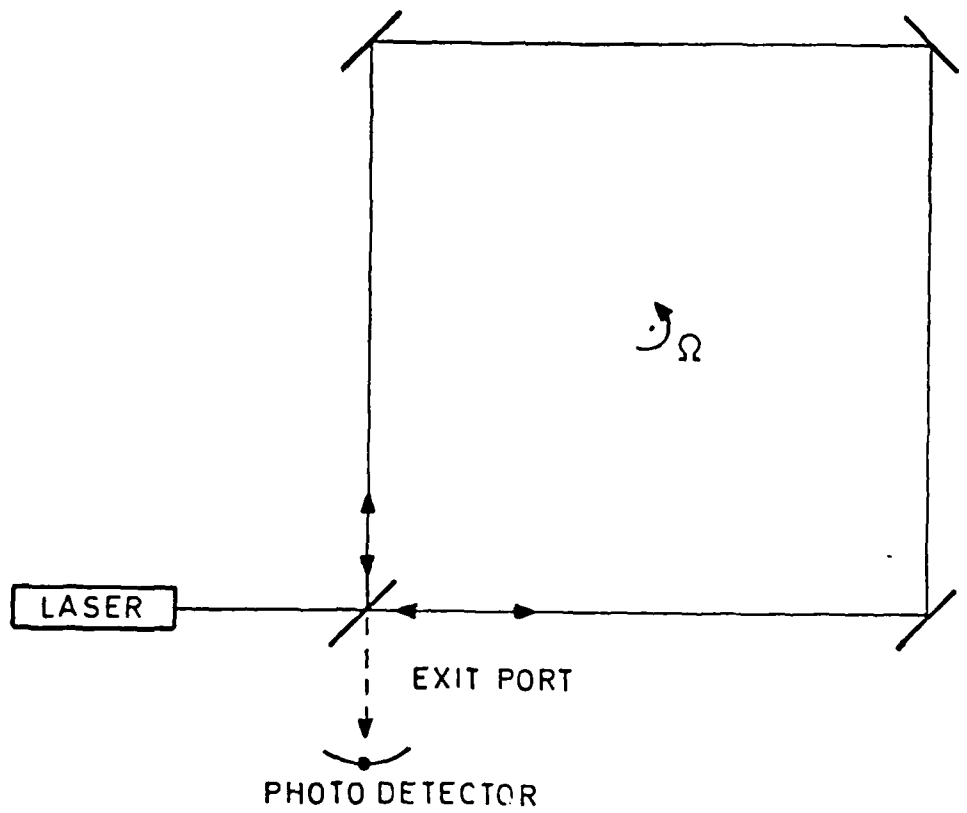

Fig. 1. Passive Ring Laser Gyro

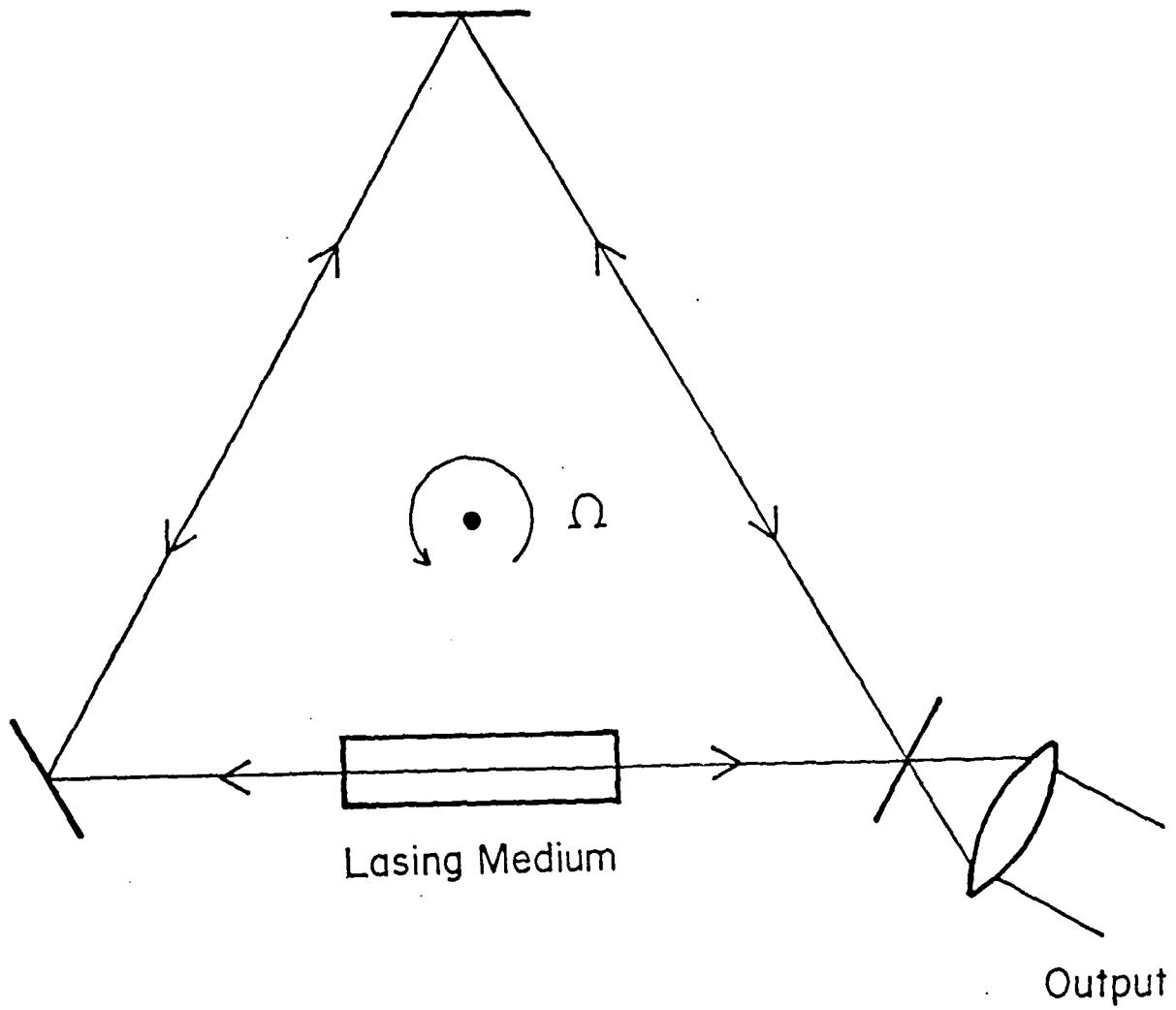
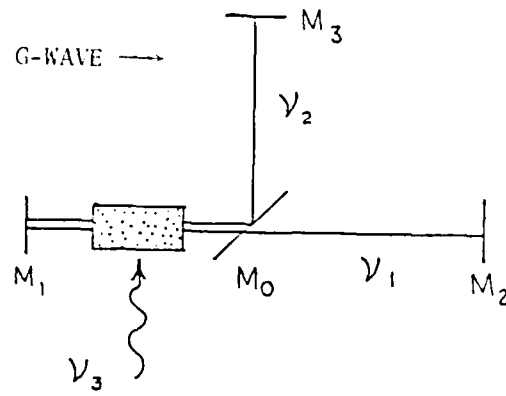
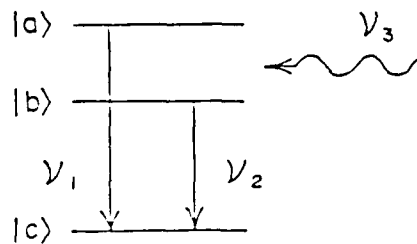

Fig. 2. Active Ring Laser Gyro



(a)



(b)

Fig. 3. CEL G-Wave Detector

- (a) Laser consisting of three-level atoms coherently mixed by external microwave signal at  $\nu_3$ . Dichroic mirror causes light to be deflected in vertical direction for frequency  $\nu_2$  but transmits light at frequency  $\nu_1$ .
- (b) Three-level atomic medium. Microwave signal,  $\nu_3$ , coherently mixes the upper,  $|a\rangle$  and  $|b\rangle$  levels.

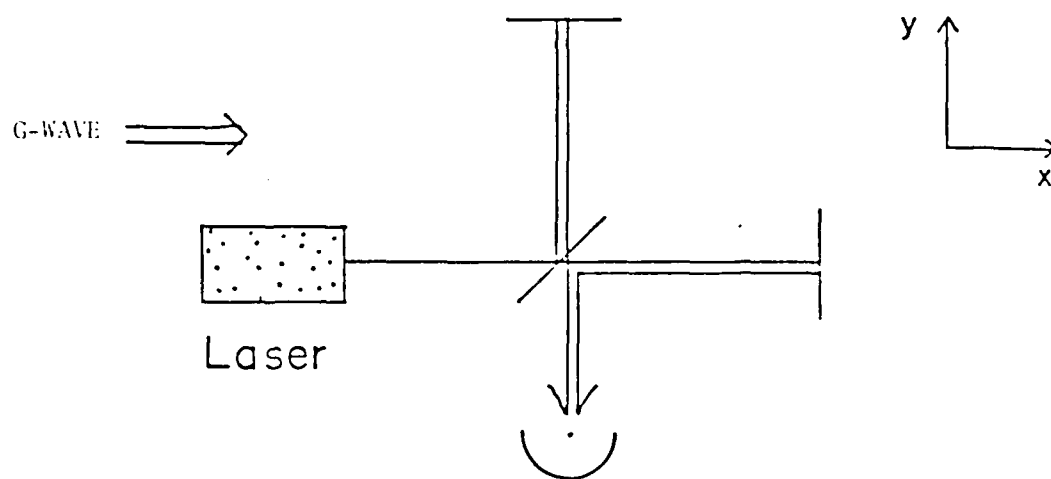

Fig. 4. Passive G-Wave Detector

G-Wave differentially changes the lengths of the arms of the Michelson interferometer.

## Correlated Spontaneous-Emission Lasers: Quenching of Quantum Fluctuations in the Relative Phase Angle

A

Marlan O. Scully

*Max-Planck-Institut für Quantenoptik, D-8046 Garching bei München, West Germany, and Center for Advanced Studies and Department of Physics and Astronomy, University of New Mexico, Albuquerque, New Mexico 87131*

(Received 26 September 1985)

In quantum-beat and Hanle-effect experiments, spontaneous-emission events from two coherently excited states are strongly correlated. A doubly resonant laser cavity driven by such atomic configurations can have vanishing diffusion coefficient for the relative phase angle.

PACS numbers: 42.50.+q, 42.55.Bi

In many areas of modern physics ultrasmall displacements are measured by placing a lasing medium in an optical cavity, and sensing a frequency shift associated with the change in optical path length caused by various effects, e.g., the motion of a mirror. In such experiments the frequency shift is typically determined by beating or heterodyning the light from the variable-frequency laser with that from a companion reference laser. Examples include the laser gyroscope,<sup>1</sup> the precision measurement of thermal-expansion coefficients,<sup>2</sup> and proposed variations on existing laser gravity-wave detectors.<sup>3</sup>

The limiting source of quantum noise in such experiments is often spontaneous-emission fluctuations<sup>4</sup> in the relative phase angle between the two lasers. In this Letter we show that diffusion of the relative phase angle between two such laser modes may be eliminated by preparing a laser medium consisting of "three-level" atoms, and arranging that the two transitions  $|a\rangle \rightarrow |c\rangle$  and  $|b\rangle \rightarrow |c\rangle$  drive a doubly resonant cavity; see Fig. 1. In this way the optical paths may be

differentially affected by the external influence of interest (e.g., a gravity wave or a Sagnac frequency shift).

However, the atomic transitions driving the two optical paths are strongly correlated when the upper levels  $|a\rangle$  and  $|b\rangle$  are prepared in a coherent superposition as in quantum-beat<sup>5</sup> or Hanle-effect<sup>6</sup> experiments. In the quantum-beat case the coherent mixing is produced by a strong<sup>7</sup> external microwave signal as in Fig. 1(a). In the Hanle-effect example, the levels  $|a\rangle$  and  $|b\rangle$  can be taken to the "linear polarization" states formed from a single "elliptical polarization" state as shown in Fig. 1(b). The fields 1 and 2 emitted by the atoms of Fig. 1(a) will differ in frequency while fields produced by the atoms of Fig. 1(b) will differ in polarization.

In both cases discussed above the heterodyne beat note between the spontaneously emitted fields 1 and 2 shows that they are strongly correlated.<sup>8</sup> To see this, consider the atoms of Figs. 1 interacting with a quantized field. The state vector is given by

$$|\psi\rangle = \alpha e^{-i\phi_a}|a, 0\rangle + \beta e^{-i\phi_b}|b, 0\rangle + \gamma_1|c, 1_1\rangle + \gamma_2|c, 1_2\rangle, \quad (1)$$

where  $|1_i\rangle$  is the state  $\hat{a}_i^\dagger|0\rangle$ ,  $i = 1, 2$ , and  $\hat{a}_i^\dagger$  ( $\hat{a}_i$ ) are the creation (annihilation) operators for photons having frequency  $\nu_i$ . Now the expectation value for the electric field operator  $\hat{E}_1$ ,

$$\hat{E}_1(\mathbf{r}, t) = \epsilon_1 \hat{a}_1 e^{i(\mathbf{k}_1 \cdot \mathbf{r} - \nu_1 t)}, \quad (2)$$

calculated using Eq. (1) is easily seen to vanish since the states  $|a\rangle$ ,  $|b\rangle$ , and  $|c\rangle$  are orthogonal. Similar arguments show that  $\langle \hat{E}_2 \rangle$  likewise vanishes. However, the cross term<sup>9</sup> does not vanish:

$$\langle \psi | \hat{E}_1^\dagger \hat{E}_2 | \psi \rangle = \epsilon_1 \epsilon_2 \gamma_1^* \gamma_2 \langle c | c \rangle \exp[-i(\mathbf{k}_1 - \mathbf{k}_2) \cdot \mathbf{r} + i(\nu_1 - \nu_2)t]. \quad (3)$$

That is, the spontaneously emitted photons at  $\nu_1$  and  $\nu_2$  are correlated.

Motivated by the preceding arguments we are led to investigate diffusion in the relative phase angle when such (three-level) lasing atoms are prepared in a coherent superposition of the upper two levels, and are placed in a doubly resonant cavity as in Fig. 1. The quantum theory of such laser configurations may be conveniently cast in terms of the following equations of motion involving Langevin quantum-noise operators<sup>4</sup> for the systems of Figs. 1. In both cases the operator equations of motion are found to be

$$\dot{\hat{a}}_1 = -i(\Omega_1 - \nu_1)\hat{a}_1 + \alpha_1 \hat{a}_1 + \alpha_{12} \hat{a}_2 e^{i\phi(t)} - \gamma_1 \hat{a}_1 + \beta_{11}(\hat{a}_1, \hat{a}_1^\dagger) + \beta_{12}(\hat{a}_1, \hat{a}_1^\dagger; \hat{a}_2, \hat{a}_2^\dagger) + \hat{F}_1(t) + \hat{G}_1(t), \quad (4a)$$

$$\dot{\hat{a}}_2 = -i(\Omega_2 - \nu_2)\hat{a}_2 + \alpha_2 \hat{a}_2 + \alpha_{21} \hat{a}_1 e^{-i\phi(t)} - \gamma_2 \hat{a}_2 + \beta_{22}(\hat{a}_2, \hat{a}_2^\dagger) + \beta_{21}(\hat{a}_2, \hat{a}_2^\dagger; \hat{a}_1, \hat{a}_1^\dagger) + \hat{F}_2(t) + \hat{G}_2(t). \quad (4b)$$

When the coherent mixing of levels  $|a\rangle$  and  $|b\rangle$  is produced via a microwave signal having frequency  $\omega_0$ , the

phase angle  $\Phi$  is given by

$$\Phi(t) = (\nu_1 - \nu_2 - \omega_0)t - \phi, \quad (5a)$$

where  $\phi$  is the (microwave determined) atomic phase difference  $\phi_a - \phi_b$ . In the case of polarization "labeling" of fields 1 and 2 as per Fig. 1(b) the phase angle is

$$\Phi(t) = (\nu_1 - \nu_2)t - \phi, \quad (5b)$$

where  $\phi$  is again the relative phase between levels  $|a\rangle$  and  $|b\rangle$  but determined this time by the state of elliptical polarization of the pump light used to excite the atoms.

The frequencies  $\Omega_i$ ,  $i=1,2$ , are the empty-cavity frequencies while  $\nu_i$  denotes the actual lasing frequencies. The detailed form of the linear gain constants ( $\alpha_1$  and  $\alpha_2$ ) and the cross-coupling coefficients ( $\alpha_{12}$  and  $\alpha_{21}$ ) need not concern us here; however, we note that they are determined respectively by the diagonal and off-diagonal elements of the atomic density matrix.

The nonlinear self-saturation and cross-coupling terms are denoted by  $\beta_{11}$  and  $\beta_{12}$  and will not be necessary for the purposes of this paper. The linear loss rate is  $\gamma_1$ . Finally, the quantum Langevin-noise operators  $\hat{F}_1$  and  $\hat{G}_1$  are associated with the gain, cross coupling, and loss for mode 1. Identical definitions apply to mode 2 with the interchange of the indices 1 and 2. The noise operators are defined by their diffusion coefficients

$$\langle \hat{G}_i^\dagger(t) \hat{G}_j(t') \rangle = 2\gamma_i \bar{n}_i \delta_{ij} \delta(t-t'), \quad (6a)$$

where  $\bar{n}_i$  is the thermal photon number for the  $i$ th cavity.<sup>10</sup> For the active medium

$$\langle \hat{F}_i^\dagger(t) \hat{F}_j(t') \rangle = 2D_{ij} \delta(t-t'), \quad (6b)$$

and the diffusion constants are determined from the generalized Einstein relation

$$2D_{ij} = \left\langle \frac{\partial}{\partial t} (\hat{a}_i^\dagger \hat{a}_j) \right\rangle - \left\langle \left( \frac{\partial \hat{a}_i^\dagger}{\partial t} \right) \hat{a}_j \right\rangle - \left\langle \hat{a}_i^\dagger \left( \frac{\partial \hat{a}_j}{\partial t} \right) \right\rangle. \quad (6c)$$

The Einstein relation<sup>11</sup> (6c) is evaluated by use of the equation of motion for the density matrix describing the laser radiation field  $\hat{\rho}(\hat{a}_1, \hat{a}_1^\dagger; \hat{a}_2, \hat{a}_2^\dagger)$ , that is,

$$\frac{d\hat{\rho}}{dt} = \sum_{ij} \hat{\mathcal{L}}_{ij} \hat{\rho}, \quad (7)$$

where the linear gain and cross-coupling Liouville operators are given by<sup>12</sup>

$$\hat{\mathcal{L}}_{11} \hat{\rho} = -\frac{1}{2} [\alpha_1 \hat{\rho} \hat{a}_1 \hat{a}_1^\dagger + \alpha_1^* \hat{a}_1 \hat{a}_1^\dagger \hat{\rho} - (\alpha_1 + \alpha_1^*) \hat{a}_1^\dagger \hat{\rho} \hat{a}_1], \quad (8a)$$

$$\hat{\mathcal{L}}_{12} \hat{\rho} = -\frac{1}{2} [\alpha_{12} \hat{\rho} \hat{a}_2 \hat{a}_1^\dagger + \alpha_{21}^* \hat{a}_2 \hat{a}_1^\dagger \hat{\rho} - (\alpha_{12} + \alpha_{21}^*) \hat{a}_1^\dagger \hat{\rho} \hat{a}_2] e^{i\Phi}, \quad (8b)$$

$$\hat{\mathcal{L}}_{21} \hat{\rho} = -\frac{1}{2} [\alpha_{21} \hat{\rho} \hat{a}_1 \hat{a}_2^\dagger + \alpha_{12}^* \hat{a}_1 \hat{a}_2^\dagger \hat{\rho} - (\alpha_{21} + \alpha_{12}^*) \hat{a}_2^\dagger \hat{\rho} \hat{a}_1] e^{-i\Phi}. \quad (8c)$$

With use of Eqs. (6), (7), and (8) we find the diffusion coefficients as they appear in Eq. (6b) to be

$$D_{ii} = \frac{1}{4} (\alpha_i + \alpha_i^*), \quad i=1,2, \quad (9a)$$

and

$$D_{12} = \frac{1}{4} (\alpha_{21} + \alpha_{12}^*) e^{-i\Phi}, \quad D_{21} = D_{12}^*. \quad (9b)$$

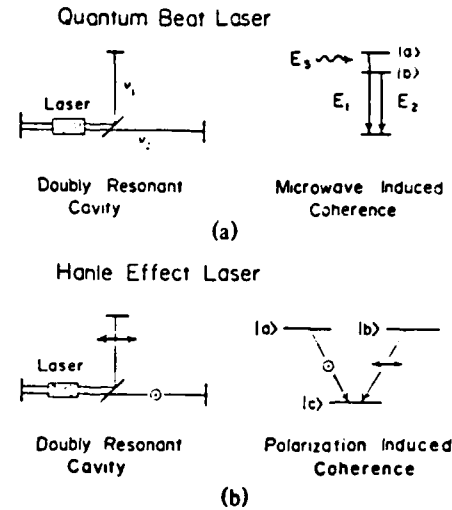

FIG. 1. (a) Active medium consisting of coherently excited three-level atoms drives doubly resonant cavity. Similar atomic configurations are prepared in quantum-beat experiments. Coherence is generated by, e.g., an external microwave field. (b) Active medium is prepared in coherent excitation of states  $|a\rangle$  and  $|b\rangle$ , which decay to state  $|c\rangle$  via emission of radiation of differing polarization states as in Hanle-effect experiments. A polarization-sensitive mirror is used to couple a doubly resonant cavity.

We may now proceed to calculate the phase diffusion time for our heterodyne average  $\langle a_1^\dagger a_2 \rangle$  with use of Eqs. (4)–(9) in the usual way (see, e.g., SSL<sup>4</sup> Sect. 20-3). We associate  $\hat{a}_i(t)$  with the complex signal  $\rho_i \exp[-i\theta_i(t)]$  and write

$$\langle \hat{a}_1^\dagger(t) \hat{a}_2(t) \rangle = \rho_1 \rho_2 \exp\left\{-\frac{1}{2} \langle [\theta_1(t) - \theta_2(t)]^2 \rangle\right\}. \quad (10)$$

The phases in Eq. (10) are determined from Eqs. (4) to be

$$\theta_i(t) = \int_{t_0}^t dt' \frac{i}{2\rho_i} [\hat{F}_i(t') e^{i\theta_i} - \hat{F}_i^\dagger(t') e^{-i\theta_i}]. \quad (11)$$

Inserting Eq. (11) into Eq. (10) and using Eqs. (9), we find

$$\langle \hat{a}_1^\dagger(t) \hat{a}_2(t) \rangle = \rho_1 \rho_2 \exp(-Dt), \quad (12a)$$

where

$$D = \frac{1}{16} \left[ \left( \frac{\alpha_1}{\rho_1^2} + \frac{\alpha_2}{\rho_2^2} \right) - \frac{(\alpha_{12} + \alpha_{21}^*) e^{-i\psi}}{\rho_1 \rho_2} \right] + \text{c.c.} \quad (12b)$$

and  $\psi = \Phi + \theta_1 - \theta_2$  with  $\theta_i$  being the phase of the  $i$ th field.

Now in deriving Eqs. (12) we have made use of the fact that the phase angle  $\psi$  will (under normal operating conditions) lock to a constant value. This constant phase angle is determined by the locking equation of motion for  $\psi(t)$  as obtained from Eqs. (4), namely<sup>13</sup>

$$\dot{\psi}(t) = a - b \sin\psi(t), \quad (13)$$

where the locking parameter  $b$  is determined (in part) by  $\alpha_{12}$  and  $\alpha_{21}$ , and  $a$  is a small frequency difference which can be made to vanish by a proper choice of  $\Omega_1 - \Omega_2$ . In that case  $\psi$  locks<sup>14</sup> to zero and the rate of phase diffusion as given by Eq. (12b) vanishes; the terms in curly brackets cancel. Detailed analysis, to be published elsewhere, shows that this can be satisfied for a variety of laser parameters. For example, when all  $\alpha$ 's were equal and  $\rho_1 = \rho_2$  then  $D$  as defined by Eq. (12b) would obviously vanish when  $\psi = 0$ . Further discussion of this point and experimental arrangements designed to maximize signal-to-noise ratio will be given in a future paper.

In addition to its intrinsic interest within the field of quantum optics, the possibility of noise suppression<sup>15</sup> via correlated-emission lasers holds promise for application in several areas of research. The analysis of such potential applications will be presented elsewhere.

The support of the U.S. Air Force Office of Scientific Research and the U.S. Office of Naval Research is gratefully acknowledged. The author wishes to express his thanks to several colleagues for seminal discussions at the University of New Mexico Center for

Advanced Studies, including D. Anderson, R. Chiao, D. Depatie, J. Gea-Banacloche, L. Pedrotti, W. Schleich, and K. Thorne. The stimulating atmosphere at the Max-Planck Institute lead to many useful discussions with J. Eberly, J. Ehlers, M. Kleber, G. Leuchs, P. Meystre, W. Sandle, M. Sargent, A. Seigman, H. Walther, K. Wodkiewicz, and S. Zubairy.

<sup>1</sup>See, for example, the recent review by W. W. Chou *et al.*, *Rev. Mod. Phys.* **57**, 61 (1981).

<sup>2</sup>J. Berthold and S. Jacobs, *Appl. Opt.* **15**, 2344 (1976).

<sup>3</sup>We have found the review by K. Thorne, *Rev. Mod. Phys.* **52**, 285 (1980), to be very helpful. For a review of recent optical work see the excellent review by C. Borde and co-workers, *Ann. Phys. (Paris)* **10**, 201 (1985); see also *Quantum Optics, Experimental Gravitation, and Measurement Theory*, edited by P. Meystre and M. O. Scully, NATO Advanced Study Institute Series B, Vol. 94 (Plenum, New York, 1983).

<sup>4</sup>M. Lax, in *Statistical Physics, Phase Transitions, and Superfluidity*, edited by M. Chretien *et al.* (Gordon and Breach, New York, 1966), Vol. 2; H. Haken, *Handbuch der Physik* (Springer-Verlag, New York, 1970); M. Sargent, III, M. O. Scully, and W. E. Lamb, Jr., *Laser Physics* (Addison-Wesley, Reading, Mass., 1974) (hereafter referred to as SSL).

<sup>5</sup>The pioneering work in quantum-beat experiments was carried out by G. Series and co-workers. The author thanks W. Sandle for stimulating discussions in this regard. The atomic-beam experiment of S. Baskin provides a dramatic example of this effect. Papers especially relevant to the present work are W. Chow, M. Scully, and J. Stoner, *Phys. Rev. A* **11**, 1380 (1975); R. Herman, H. Grotch, R. Kornblith, and J. Eberly, *Phys. Rev. A* **11**, 1389 (1975); I. Senitzky, *Phys. Rev. Lett.* **35**, 1755 (1975).

<sup>6</sup>W. Hanle, *Z. Phys.* **30**, 93 (1924). An account of this problem oriented along the present lines is given by M. Scully, in *Atomic Physics I*, edited by B. Bederson, V. W. Cohen, and F. M. Pichanick (Plenum, New York, 1969), p. 81.

<sup>7</sup>The microwave field must be a strong field since states  $|a\rangle$  and  $|b\rangle$  cannot be coupled by a dipole transition, since the transitions  $|a\rangle$  to  $|c\rangle$  and  $|b\rangle$  to  $|c\rangle$  obey dipole selection rules. One would therefore anticipate a weaker coupling between the upper two levels and would compensate for this by, for example, driving the transition with a strong external field. Alternatively one could use, e.g., a molecular system in which parity is not a good quantum number.

<sup>8</sup>The notion of correlated spontaneous emission is discussed in Ref. 7 and also more recently in M. Scully and K. Drühl, *Phys. Rev. A* **25**, 2203 (1982). See also the interesting recent paper by I. Senitzky, *J. Opt. Soc. Am. B* **1**, 879 (1984).

<sup>9</sup>For a discussion of optical correlation theory see R. Glauber, in *Quantum Optics and Electronics*, edited by B. DeWitt *et al.* (Gordon and Breach, New York, 1964). We are here using the Onsager regression theorem as applied in Chap. 18 of SSL, Ref. 4.

<sup>10</sup>We may take the number of thermal photons  $\bar{n}_i$  to be zero for the optical transitions here considered.

<sup>11</sup>The partial derivatives in Eq. (6) remind us that the Einstein relation is found from mean drift only (ignoring diffusion). The Einstein relation measures the extent to which the usual product rule of differentiation does not apply to stochastic processes.

<sup>12</sup>The exact form of the  $\alpha$ 's need not concern us here and will be given in the quantum-beat laser case in a forthcoming paper by M. Scully and S. Zubairy. The Hanle-laser parameters will be published in a paper by J. Gea-Banacloche and M. Scully.

<sup>13</sup>A discussion of mode locking as it appears in the present problem can be found in SSL (Ref. 4), or in Ref. 1.

<sup>14</sup>Although the phase locks, information associated with path length differences can still be extracted by various strategies. For example, the relative phase between the two beams will be shifted by the frequency differential of interest according to the expression  $\delta\psi = a/b$  for the small frequency shifts we wish to measure. Other measurement

strategies using correlated spontaneous-emission lasers will be discussed elsewhere.

<sup>15</sup>In conversations with my colleagues it has been necessary to point out that this work is unrelated to the beautiful "two-photon-squeezed state" studies of C. Caves, J. Shapiro, D. Walls, H. Yuen, and co-workers. However, upon completion of this paper it was pointed out to the author that there is an interesting connection between the present work and the cross-correlation studies of B. Dalton and P. Knight, *J. Phys. B* **15**, 3997 (1982), and *Opt. Commun.* **42**, 411 (1982); and of T. Kennedy and S. Swain, *J. Phys. D* **17**, 1751 (1984). In their studies they consider the noise reduction effects of *nonlinear* (third-order) cross coupling whereas our coupling is first order. They find that the linewidth can be reduced by a factor of one-half through this nonlinear coupling effect whereas our results lead to a vanishing linewidth. The author is indebted to S. Zubairy for pointing out these references.

Theory of the Quantum Beat Laser

(B)

M.O. Scully and M.S. Zubairy\*

Max-Planck-Institut für Quantenoptik  
D-8046 Garching bei München  
West Germany

and

Center for Advanced Studies  
Department of Physics and Astronomy  
University of New Mexico  
Albuquerque, New Mexico 87131

ABSTRACT

A theory of the quantum beat laser is developed using a general Fokker-Planck approach. An explicit expression for the diffusion coefficient for the relative phase angle of the two modes is derived. It is shown that the diffusion coefficient can vanish under certain conditions.

\*Permanent Address: Department of Physics  
Quaid-i-Azam University  
Islamabad, Pakistan

## 1. INTRODUCTION

In a recent paper [1], it was shown that the linewidth and the attendant uncertainty of the difference frequency between two laser modes may be eliminated by preparing the laser medium in a coherent superposition of two upper states as in quantum beat experiments [2,3]. Such a "quantum beat laser" has potential application in many areas e.g., gravitational wave detection [4,5] and tests of metric theories of gravitation [6].

The arguments of Ref. [1] were of a general nature but expressions for the various laser parameter e.g. gain and cross coupling coefficients were not given. In this paper we develop a more general Fokker-Planck approach to this problem and derive an explicit expression for the diffusion constant for the relative phase angle of the two modes. The conditions under which this diffusion constant vanishes are given.

## 2. EQUATION OF MOTION FOR THE DENSITY MATRIX

We consider a system of three level atoms, as shown in Fig. 1, which are being pumped in the state  $|a\rangle$  at a rate  $r_a$ . The laser cavity is arranged such that it would resonantly contain both modes  $\nu_1$  and  $\nu_2$ . The transitions between levels  $|a\rangle - |c\rangle$  are assumed dipole allowed. The dipole forbidden  $|a\rangle - |b\rangle$  transition is induced by some external means (such as, for instance, by applying a strong magnetic field for a magnetic dipole-allowed transition). The corresponding Rabi frequency is denoted by  $\Omega e^{-i\phi}$  where  $\Omega$  and  $\phi$  are the real amplitude and phase. We shall treat the  $|a\rangle - |b\rangle$  transition semiclassically and to all orders in the Rabi frequency. The  $|a\rangle - |c\rangle$  transitions will be treated fully quantum mechanically but only to the second-order in the corresponding coupling constants.

The Hamiltonian for the system is

$$H = H_0 + V, \tag{1a}$$

$$H_0 = \sum_{i=a,b,c} \hbar \omega_i |i\rangle \langle i| + \hbar \nu_1 a_1^\dagger a_1 + \hbar \nu_2 a_2^\dagger a_2, \quad (1b)$$

$$\begin{aligned} V = & \hbar g_1 (a_1 |a\rangle \langle c| + a_1^\dagger |c\rangle \langle a|) \\ & + \hbar g_2 (a_2 |b\rangle \langle c| + a_2^\dagger |c\rangle \langle b|) \\ & - \frac{\hbar \Omega}{2} (e^{-i\phi - i\nu_3 t} |a\rangle \langle b| + e^{i\phi + i\nu_3 t} |b\rangle \langle a|), \end{aligned} \quad (1c)$$

where  $a_1, a_1^\dagger, a_2, a_2^\dagger$  are the destruction and creation operators for the fields in modes of frequencies  $\nu_1$  and  $\nu_2$  respectively,  $g_1$  and  $g_2$  are the coupling constants associated with the  $|a\rangle - |c\rangle$  and  $|b\rangle - |c\rangle$  transitions respectively, and  $\nu_3$  is the frequency of the field which induces the transition between levels  $|a\rangle$  and  $|b\rangle$  and it is assumed to be at resonance with the  $|a\rangle - |b\rangle$  transition, i.e.,  $\nu_3 = \omega_a - \omega_b$ .

In order to derive the equation of motion for the reduced density matrix for the field  $\rho_F$  we first obtain an equation for the off-diagonal matrix element:

$$\begin{aligned} \langle n_1, n_2 | \rho_F | n'_1, n'_2 \rangle = & \langle a, n_1, n_2 | \rho | a, n'_1, n'_2 \rangle \\ & + \langle b, n_1, n_2 | \rho | b, n'_1, n'_2 \rangle \\ & + \langle c, n_1, n_2 | \rho | c, n'_1, n'_2 \rangle, \end{aligned} \quad (2)$$

where  $\rho$  is the atom-field density matrix and a trace over atomic states is taken. Let us define the following atom-field states.

$$|1\rangle = |a, n_1 - 1, n_2\rangle, \quad (3a)$$

$$|2\rangle = |b, n_1, n_2 - 1\rangle, \quad (3b)$$

$$|3\rangle = |c, n_1, n_2\rangle. \quad (3c)$$

The Schrödinger equation for the matrix element  $\langle n_1, n_2 | \dot{\rho}_F | n_1', n_2' \rangle$  is therefore

$$\begin{aligned}
 \langle n_1, n_2 | \dot{\rho}_F | n_1', n_2' \rangle = & -\frac{i}{\hbar} (V_{13} \rho_{31'} - \rho_{13'} V_{3'1'})_{\substack{n_1 \rightarrow n_1+1 \\ n_1' \rightarrow n_1'+1}} \\
 & -\frac{i}{\hbar} (V_{23} \rho_{32'} - \rho_{23'} V_{3'2'})_{\substack{n_2 \rightarrow n_2+1 \\ n_2' \rightarrow n_2'+1}} \\
 & -\frac{i}{\hbar} (V_{31} \rho_{13'} + V_{32} \rho_{23'} \\
 & - \rho_{31'} V_{1'3'} - \rho_{32'} V_{2'3'}) .
 \end{aligned} \tag{4}$$

We must now evaluate  $\rho_{31'}$ ,  $\rho_{13'}$ ,  $\rho_{32'}$ , and  $\rho_{23'}$ .

The wave vector  $|\psi\rangle$  can be expanded in terms of the eigenstates of the atom-field system:

$$|\psi\rangle = \sum_{i=a,b,c} \sum_{m_1, m_2} A_{i m_1 m_2} |i, m_1, m_2\rangle, \tag{5}$$

where  $A_{i m_1 m_2}$  is the probability amplitude for finding the atom in state  $|i\rangle$  and the fields of modes 1 and 2 in the states  $|m_1\rangle$  and  $|m_2\rangle$  respectively. We first treat the  $|a\rangle - |b\rangle$  transition semi-classically to all orders in  $\Omega$ . The equations of motion for the amplitudes  $A_{a n_1 n_2}$  and  $A_{b n_1 n_2}$  are

$$\dot{A}_{a n_1 n_2} = -i(\omega_a' - \frac{i\gamma}{2}) A_{a n_1 n_2} + \frac{i\Omega}{2} e^{-i\phi - i\nu_3 t} A_{b n_1 n_2}, \tag{6}$$

$$\dot{A}_{b n_1 n_2} = -i(\omega_b' - \frac{i\gamma}{2}) A_{b n_1 n_2} + \frac{i\Omega}{2} e^{i\phi + i\nu_3 t} A_{a n_1 n_2}, \tag{7}$$

where  $\omega_i' = \omega_i + n_1 \nu_1 + n_2 \nu_2$  ( $i = a, b, c$ ) and  $\gamma$  is the decay constant for the levels  $a, b$ , and  $c$  (for simplicity we have taken them equal). If the atoms are injected at random initial times  $t_0$  in level  $|a\rangle$ , the solution of Eqs. (6) and (7) is

$$A_{a, n_1, n_2}(t) = e^{-i(\omega_a' - i\frac{\gamma}{2})(t-t_0)} \cos\left(\frac{\Omega}{2}(t-t_0)\right) A_{n_1, n_2}^F, \quad (8a)$$

$$A_{b, n_1, n_2}(t) = i e^{-i\phi - i\omega_b' t + i\omega_a' t_0 - \frac{\gamma}{2}(t-t_0)} \sin\left(\frac{\Omega}{2}(t-t_0)\right) A_{n_1, n_2-1}^F, \quad (8b)$$

where  $A_{n_1, n_2}^F$  are the probability amplitudes for the field only. The equation of motion for the amplitude  $A_{c, n_1, n_2}$  is

$$\dot{A}_{c, n_1, n_2} = -i\left(\omega_c' - \frac{i\gamma}{2}\right) A_{c, n_1, n_2} - i g_1 \sqrt{n_1} A_{a, n_1-1, n_2} - i g_2 \sqrt{n_2} A_{b, n_1, n_2-1}. \quad (9)$$

Here we treat the  $|a\rangle - |c\rangle$  and  $|b\rangle - |c\rangle$  transitions to the lowest order only. It follows, on integrating Eq. (9), that

$$A_{c, n_1, n_2}(t) = -i \int_{t_0}^t d\tau e^{-i\left(\omega_c' - \frac{i\gamma}{2}\right)(t-\tau)} \left[ g_1 \sqrt{n_1} A_{a, n_1-1, n_2}(\tau) + g_2 \sqrt{n_2} A_{b, n_1, n_2-1}(\tau) \right], \quad (10)$$

where  $A_{a, n_1-1, n_2}$  and  $A_{b, n_1, n_2-1}$  can be obtained by appropriately shifting  $n_1$  and  $n_2$  in Eqs. (8a) and (8b).

We can now determine  $S_{13}'$  by summing the contribution  $A_{a, n_1-1, n_2}(t) A_{c, n_1, n_2}^*(t)$  of all atoms which are injected at random times at a rate  $r_a$ , i.e.,

$$S_{13}' = r_a \int_{-\infty}^t dt_0 A_{a, n_1-1, n_2}(t) A_{c, n_1, n_2}^*(t) \quad (11)$$

On substituting from Eqs. (8a) and (10) we obtain after some straightforward algebra:

$$S_{13}' = T_{11} \langle n_1-1, n_2 | \rho_F | n_1-1, n_2 \rangle + T_{12} \langle n_1-1, n_2 | \rho_F | n_1, n_2-1 \rangle, \quad (12)$$

where

$$T_{11} = i g_1 \sqrt{n_1} \nu_a \left[ \left( \frac{1}{\gamma - i\Omega} + \frac{1}{\gamma} \right) \frac{1}{(\gamma + i(\Delta_1 - \frac{\Omega}{2}))} + \left( \frac{1}{\gamma + i\Omega} + \frac{1}{\gamma} \right) \frac{1}{(\gamma + i(\Delta_1 + \frac{\Omega}{2}))} \right], \quad (13a)$$

$$T_{12} = -i g_2 \sqrt{n_2} \nu_a \left[ \left( \frac{1}{\gamma - i\Omega} - \frac{1}{\gamma} \right) \frac{1}{(\gamma + i(\Delta_2 - \frac{\Omega}{2}))} - \left( \frac{1}{\gamma + i\Omega} - \frac{1}{\gamma} \right) \frac{1}{(\gamma + i(\Delta_2 + \frac{\Omega}{2}))} \right] e^{i\Phi(t)}, \quad (13b)$$

with  $\Delta_1 = \omega_a - \omega_c - \nu_1$ ,  $\Delta_2 = \omega_b - \omega_c - \nu_2$ , and  $\Phi(t) = (\nu_1 - \nu_2 - \nu_3)t - \phi$ . In a similar manner we obtain

$$\mathcal{S}_{23}' = T_{22} \langle n_1, n_2 - 1 | \mathcal{S}_F | n_1', n_2' - 1 \rangle + T_{21} \langle n_1, n_2 - 1 | \mathcal{S}_F | n_1' - 1, n_2' \rangle, \quad (14)$$

where

$$T_{22} = i g_2 \sqrt{n_2} \nu_a \left[ \left( \frac{1}{\gamma - i\Omega} - \frac{1}{\gamma} \right) \frac{1}{(\gamma + i(\Delta_2 - \frac{\Omega}{2}))} + \left( \frac{1}{\gamma + i\Omega} - \frac{1}{\gamma} \right) \frac{1}{(\gamma + i(\Delta_2 + \frac{\Omega}{2}))} \right], \quad (15a)$$

$$T_{21} = i g_1 \sqrt{n_1} \nu_a \left[ \left( \frac{1}{\gamma - i\Omega} + \frac{1}{\gamma} \right) \frac{1}{(\gamma + i(\Delta_1 - \frac{\Omega}{2}))} - \left( \frac{1}{\gamma + i\Omega} + \frac{1}{\gamma} \right) \frac{1}{(\gamma + i(\Delta_1 + \frac{\Omega}{2}))} \right] e^{-i\Phi}. \quad (15b)$$

Also

$$\mathcal{S}_{31}' = T_{11}^* \langle n_1 - 1, n_2 | \mathcal{S}_F | n_1' - 1, n_2' \rangle + T_{12}^* \langle n_1, n_2 - 1 | \mathcal{S}_F | n_1', n_2' \rangle, \quad (16)$$

$$\mathcal{S}_{32}' = T_{22}^* \langle n_1, n_2 - 1 | \mathcal{S}_F | n_1', n_2' - 1 \rangle + T_{21}^* \langle n_1 - 1, n_2 | \mathcal{S}_F | n_1', n_2' - 1 \rangle. \quad (17)$$

It then follows, on substituting for  $\mathcal{S}_{12}'$ ,  $\mathcal{S}_{31}'$ ,  $\mathcal{S}_{32}'$ , and  $\mathcal{S}_{23}'$  from Eqs. (12), (14), (15), and (16) in Eq. (4), that

$$\dot{S}_F = \sum_{i,j=1}^2 L_{ij} (a_i, a_i^+) S_F, \quad (18)$$

where

$$L_{ii} S_F = -\frac{1}{2} [\alpha_{ii}^* a_i a_i^+ S_F + \alpha_{ii} S_F a_i a_i^+ - (\alpha_{ii} + \alpha_{ii}^*) \times a_i^+ S_F a_i], \quad (19a)$$

$$L_{12} S_F = -\frac{1}{2} [\alpha_{21}^* a_1^+ a_2 S_F + \alpha_{12} S_F a_1^+ a_2 - (\alpha_{12} + \alpha_{21}^*) \times a_1^+ S_F a_2] e^{i\Phi} \quad (19b)$$

$$L_{21} S_F = -\frac{1}{2} [\alpha_{12}^* a_1 a_2^+ S_F + \alpha_{21} S_F a_1 a_2^+ - (\alpha_{21} + \alpha_{12}^*) \times a_2^+ S_F a_1] e^{-i\Phi} \quad (19c)$$

with

$$\alpha_{11} = \frac{g_1^2 \lambda_a}{2} \left[ \left( \frac{1}{\gamma} + \frac{i}{\gamma - i\Omega} \right) \frac{i}{(\gamma + i(\Delta_1 - \frac{\Omega}{2}))} + \left( \frac{1}{\gamma} + \frac{i}{\gamma + i\Omega} \right) \frac{i}{(\gamma + i(\Delta_1 + \frac{\Omega}{2}))} \right], \quad (20a)$$

$$\alpha_{12} = \frac{g_1 g_2 \lambda_a}{2} \left[ \left( \frac{1}{\gamma} - \frac{i}{\gamma - i\Omega} \right) \frac{i}{(\gamma + i(\Delta_2 - \frac{\Omega}{2}))} - \left( \frac{1}{\gamma} - \frac{i}{\gamma + i\Omega} \right) \frac{i}{(\gamma + i(\Delta_2 + \frac{\Omega}{2}))} \right], \quad (20b)$$

$$\alpha_{21} = \frac{g_1 g_2 \lambda_a}{2} \left[ \left( \frac{1}{\gamma} + \frac{i}{\gamma - i\Omega} \right) \frac{i}{(\gamma + i(\Delta_1 - \frac{\Omega}{2}))} - \left( \frac{1}{\gamma} + \frac{i}{\gamma + i\Omega} \right) \frac{i}{(\gamma + i(\Delta_1 + \frac{\Omega}{2}))} \right], \quad (20c)$$

$$\alpha_{22} = \frac{g_2^2 \lambda_a}{2} \left[ \left( \frac{1}{\gamma} - \frac{i}{\gamma - i\Omega} \right) \frac{i}{(\gamma + i(\Delta_2 - \frac{\Omega}{2}))} + \left( \frac{1}{\gamma} - \frac{i}{\gamma + i\Omega} \right) \frac{i}{(\gamma + i(\Delta_2 + \frac{\Omega}{2}))} \right]. \quad (20d)$$

In Eq. (18) we ignored the cavity loss terms because they do not contribute to the diffusion constant of the relative phase angle.

### 3. FOKKER-PLANCK EQUATION AND VANISHING OF DIFFUSION CONSTANT FOR RELATIVE PHASE

We now derive the Fokker-Planck equation for the coherent-state representation for the field  $P(\varepsilon_1, \varepsilon_2)$  which is defined by

$$\rho_F = \int P(\varepsilon_1, \varepsilon_2) |\varepsilon_1, \varepsilon_2\rangle \langle \varepsilon_1, \varepsilon_2| d^2\varepsilon_1 d^2\varepsilon_2 . \quad (21)$$

Here  $|\varepsilon_1, \varepsilon_2\rangle$  is the coherent state which is an eigenstate of  $a_1$  and  $a_2$  with eigenvalues  $\varepsilon_1$  and  $\varepsilon_2$  respectively. By using the relations [7]

$$a_i |\varepsilon_1, \varepsilon_2\rangle = \varepsilon_i |\varepsilon_1, \varepsilon_2\rangle , \quad (22a)$$

$$a_i^+ |\varepsilon_1, \varepsilon_2\rangle = \left( \frac{\partial}{\partial \varepsilon_i} + \frac{\varepsilon_i^*}{2} \right) |\varepsilon_1, \varepsilon_2\rangle , \quad (22b)$$

we can reduce the density operator equation (18) to a c-number equation for  $P$ . The resulting Fokker-Planck equation in terms of the variables  $\rho_1, \rho_2, \theta$  and  $\mu$ , where

$$\rho_i = |\varepsilon_i|^2 \quad (i = 1, 2) , \quad (23a)$$

$$\theta = \theta_1 - \theta_2 , \quad (23b)$$

$$\mu = \frac{1}{2} (\theta_1 + \theta_2) , \quad (23c)$$

$$\theta_i = i \ln \left( \frac{\varepsilon_i}{\rho_i} \right) \quad (i = 1, 2) , \quad (23d)$$

is

$$\begin{aligned}
 \dot{P} = & d_0 P + d(\beta_1) \frac{\partial P}{\partial \beta_1} + d(\beta_2) \frac{\partial P}{\partial \beta_2} + d(\mu) \frac{\partial P}{\partial \mu} \\
 & + d(\theta) \frac{\partial P}{\partial \theta} + D(\theta) \frac{\partial^2 P}{\partial \theta^2} + D(\mu) \frac{\partial^2 P}{\partial \mu^2} + D(\beta_1) \frac{\partial^2 P}{\partial \beta_1^2} \\
 & + D(\beta_2) \frac{\partial^2 P}{\partial \beta_2^2} + D(\theta, \mu) \frac{\partial^2 P}{\partial \theta \partial \mu} + D(\beta_1, \beta_2) \frac{\partial^2 P}{\partial \beta_1 \partial \beta_2} \\
 & + D(\beta_1, \mu) \frac{\partial^2 P}{\partial \beta_1 \partial \mu} + D(\beta_2, \mu) \frac{\partial^2 P}{\partial \beta_2 \partial \mu} \\
 & + D(\beta_1, \theta) \frac{\partial^2 P}{\partial \beta_1 \partial \theta} + D(\beta_2, \theta) \frac{\partial^2 P}{\partial \beta_2 \partial \theta} ,
 \end{aligned} \tag{24}$$

with

$$d_0 = -\frac{1}{2} [\alpha_1 + \alpha_2] + c.c. , \tag{25a}$$

$$d(\beta_1) = -\frac{i}{4} \left[ \alpha_{11} \left( \beta_1 - \frac{1}{2\beta_1} \right) + \alpha_{12} \beta_2 e^{-i\psi} \right] + c.c. , \tag{25b}$$

$$d(\beta_2) = -\frac{i}{4} \left[ \alpha_{22} \left( \beta_2 - \frac{1}{2\beta_2} \right) + \alpha_{21} \beta_1 e^{i\psi} \right] + c.c. , \tag{25c}$$

$$d(\mu) = \frac{i}{8} \left[ \alpha_{11} + \alpha_{22} + \alpha_{12} \frac{\beta_2}{\beta_1} e^{-i\psi} + \alpha_{21} \frac{\beta_1}{\beta_2} e^{i\psi} \right] + c.c. , \tag{25d}$$

$$d(\theta) = -\frac{i}{4} \left[ \alpha_{11} - \alpha_{22} + \alpha_{12} \frac{\beta_2}{\beta_1} e^{-i\psi} - \alpha_{21} \frac{\beta_1}{\beta_2} e^{i\psi} \right] + c.c. , \tag{25e}$$

$$D(\theta) = \frac{1}{8} \left[ \frac{\alpha_{11}}{\beta_1^2} + \frac{\alpha_{22}}{\beta_2^2} - \frac{\alpha_{12}}{\beta_1 \beta_2} e^{-i\psi} - \frac{\alpha_{21}}{\beta_1 \beta_2} e^{i\psi} \right] + c.c. , \tag{25f}$$

$$D(\mu) = \frac{1}{32} \left[ \frac{\alpha_{11}}{\beta_1^2} + \frac{\alpha_{22}}{\beta_2^2} + \frac{\alpha_{12}}{\beta_1 \beta_2} e^{-i\psi} + \frac{\alpha_{21}}{\beta_1 \beta_2} e^{i\psi} \right] + c.c. , \tag{25g}$$

$$D(\beta_1) = \frac{\alpha_{11}}{8\beta_1^2} + c.c. , \tag{25h}$$

$$D(\beta_2) = \frac{\alpha_{22}}{8\beta_2^2} + c.c. , \tag{25i}$$

$$D(\theta, \mu) = \frac{1}{8} \left[ \frac{\alpha_{11}}{\beta_1^2} - \frac{\alpha_{22}}{\beta_2^2} \right] + c.c. , \quad (25j)$$

$$D(\beta_1, \beta_2) = \frac{1}{8} \left[ \alpha_{12} e^{-i\psi} + \alpha_{21} e^{i\psi} \right] + c.c. , \quad (25k)$$

$$D(\beta_1, \mu) = \frac{i}{16\beta_2} \left[ \alpha_{21} e^{i\psi} - \alpha_{12} e^{-i\psi} \right] + c.c. , \quad (25l)$$

$$D(\beta_2, \mu) = \frac{i}{16\beta_1} \left[ \alpha_{12} e^{-i\psi} - \alpha_{21} e^{i\psi} \right] + c.c. , \quad (25m)$$

$$D(\beta_1, \theta) = \frac{-i}{8\beta_2} \left[ \alpha_{21} e^{i\psi} + \alpha_{12} e^{-i\psi} \right] + c.c. , \quad (25n)$$

$$D(\beta_2, \theta) = \frac{-i}{8\beta_1} \left[ \alpha_{12} e^{-i\psi} + \alpha_{21} e^{i\psi} \right] + c.c. , \quad (25p)$$

and  $\psi = \theta + \phi$ .

We are interested in finding conditions under which the diffusion constant  $D(\theta)$  for the relative phase angle  $\theta = \theta_1 - \theta_2$  of the two modes vanish. Here we mention two such conditions.

When  $\psi = 0$ ,  $\beta_1 = \beta_2 = \beta$  then  $D(\theta) = 0$  if

$$\text{Re}(\alpha_{11} + \alpha_{22} - \alpha_{12} - \alpha_{21}) = 0 . \quad (26)$$

This equation is satisfied (with  $g_1 = g_2$ ) when

$$\Delta_1 = \frac{\Omega}{2} + \frac{2\gamma^2}{\Omega} , \quad (27a)$$

$$\Delta_2 = -\frac{3\Omega}{2} . \quad (27b)$$

This gives a condition on the detunings, the Rabi frequency of the driving field that couples levels  $|a\rangle$  and  $|b\rangle$ , and the decay constants of the atomic levels.

Another interesting condition under which the spontaneous emission in the two-modes gets highly correlated is (with  $g_1 = g_2 = g$ ,

$$\rho_1 = \rho_2 = \rho)$$

$$\Omega \gg \gamma, \quad (28a)$$

$$\Delta_1 = \Delta_2 = \frac{\Omega}{2}, \quad (28b)$$

i.e., the field detunings from the corresponding atomic lines are equal to the half the Rabi frequency of the driving field that coherently mixes the level  $|a\rangle$  and  $|b\rangle$  and they are much larger than the atomic decay constant. In this case (For details, see Appendix A)

$$D(\theta) = \frac{\alpha_0}{4\beta^2} (1 - \cos\psi), \quad (29)$$

where

$$\alpha_0 = \frac{\beta^2 \lambda_a}{2\gamma^2}. \quad (30)$$

When  $\psi = 0$ , the vanishing of the diffusion constant takes place.

In order to establish the stability of these conditions, a nonlinear theory of the quantum beat laser needs to be formulated. The present approach, however, shows in a simple way that it is possible for a two-mode laser to have a vanishing diffusion constant for the relative phase angle. It is interesting to note that the conditions under which  $D(\theta)=0$  does not lead to a vanishing of  $D(\mu)$  where  $\mu = (\theta_1 + \theta_2)/2$ . Physically we can understand the quenching of the spontaneous emission fluctuations in the relative phase  $\theta$  by referring to Fig. 2. Here we consider the "random walk" of the tips of electric field phases of the two modes in the complex  $\alpha$ -phase. If we ignore the amplitude fluctuations, the phase fluctuations in the field associated with the spontaneous emission allows the tips of the field to diffuse out around a circle in the complex plane. When  $D(\theta) = 0$ , the spontaneous emission in the two modes becomes highly correlated so that the relative phase angle  $\theta$  is "locked" to a particular value (say  $\theta_0$ ). The average phase variable  $\mu$  has however nonvanishing diffusion.

#### 4. CONCLUDING REMARKS

We have shown that in a "quantum beat laser" the spontaneous emission noise in the two modes can be made highly correlated under certain conditions. It is worthwhile to mention that in a recent paper, Kennedy and Swain [8] show the high correlation between the two modes well above threshold in a coupled two-mode laser [9]. A careful analysis of their results however indicates that the diffusion constant for the relative phase angle of the two modes  $D(\theta)$  ( $\mu(1,-1)$  in the notation of Ref. [8]) in the coupled two-mode laser is equal to  $C/2\bar{n}$ , independent of how far above threshold the laser is operating. (Here  $C$  is the cavity loss parameter and  $\bar{n}$  is the mean number of photons in either mode). An alternative derivation of their results using a Fokker-Planck approach is given in Appendix B. Well above threshold ( $\alpha \gg C$ ;  $\alpha$  being the gain coefficient) there is therefore a reduction of the order  $C/\alpha$ . This is in contrast with the results of this paper where we show a cancellation of all the terms proportional to  $\alpha/\bar{n}$  (since  $\alpha = C$  near threshold) in the diffusion constant  $D(\theta)$ .

#### ACKNOWLEDGEMENTS

The authors wish to thank J. Gea-Banachloche, G. Leuchs, L. Pedrotti, W. Sandle, and H. Walther for many useful discussions. This research was supported by the U.S. Office of Naval Research and the U.S. Air Force Office of Scientific Research.

APPENDIX A: SIMPLE ASSYNTOTIC FORM FOR  $\alpha_{ij}$  WHEN  $\Delta_1 = \Delta_2 = \Omega/2$  AND  $\Omega \gg \gamma$

It follows from Eq. (20a) that, when  $\Delta_1 = \Delta_2 = \Delta$  and  $\Delta = \Omega/2$ ,

$$\alpha_{11} = \frac{g^2 \lambda_a}{2} \left[ \left( \frac{1}{\gamma} + \frac{\gamma + i\Omega}{\gamma^2 + \Omega^2} \right) \frac{1}{\gamma} + \left( \frac{1}{\gamma} + \frac{\gamma - i\Omega}{\gamma^2 + \Omega^2} \right) \frac{\gamma - i\Omega}{\gamma^2 + \Omega^2} \right]. \quad (A1)$$

We have assumed  $g_1 = g_2 = g$ . It follows from Eq. (A1) that

$$\text{Re } \alpha_{11} = \frac{g^2 \lambda_a}{2} \left[ \frac{1}{\gamma^2} + \frac{2}{\gamma^2 + \Omega^2} + \frac{\gamma^2 - \Omega^2}{(\gamma^2 + \Omega^2)^2} \right]. \quad (A2)$$

when  $\Omega \gg \gamma$ , Eq. (A2) simplifies considerably and we obtain

$$\text{Re } \alpha_{11} \approx \frac{g^2 \lambda_a}{2} \left[ \frac{1}{\gamma^2} + o\left(\frac{1}{\Omega^2}\right) \right]. \quad (A3)$$

Similarly

$$\text{Re } \alpha_{22} \approx \frac{g^2 \lambda_a}{2} \left[ \frac{1}{\gamma^2} + o\left(\frac{1}{\Omega^2}\right) \right]. \quad (A4)$$

Also

$$\begin{aligned} \alpha_{12} + \alpha_{21}^* &= \frac{g^2 \lambda_a}{2} \left[ \frac{2}{\gamma^2} - \frac{2(\gamma + i\Omega)}{\gamma(\gamma^2 + \Omega^2)} - \frac{4i\Omega\gamma}{(\gamma^2 + \Omega^2)^2} \right] \\ &\approx \frac{g^2 \lambda_a}{2} \left[ \frac{2}{\gamma^2} + o\left(\frac{1}{\Omega^2}\right) \right]. \end{aligned} \quad (A5)$$

It follows, on substituting for  $\text{Re } \alpha_{11}$ ,  $\text{Re } \alpha_{22}$ , and  $\alpha_{12} + \alpha_{21}^*$  from Eqs. (A3) - (A5) in Eq. (25f), that  $D(\theta)$  is given by Eq. (29).

APPENDIX B: DERIVATION OF  $D(\theta)$  IN THE COUPLED TWO-MODE LASER MODEL OF REF. [8] USING FOKKER-PLANCK APPROACH

Here we derive the diffusion coefficient for the relative phase angle of the two modes in the coupled two-mode laser model of Ref. [9]. The equation of motion for the matrix elements  $\rho(n_1, n_2; m_1, m_2) = \langle n_1, n_2 | \rho_F | m_1, m_2 \rangle$  of the reduced density matrix for the field is [8].

$$\begin{aligned} \dot{\rho}(n_1, n_2; m_1, m_2) = & - \left[ \frac{A}{2} (n_1 + 1 + m_1 + 1) + \frac{B}{16} (m_1 - n_1 + m_2 - n_2)^2 \right] \rho \\ & \times \mu(n_1, n_2; m_1, m_2) + A \sqrt{n_1 m_1} \mu(n_1 - 1, n_2; m_1 - 1, m_2) \\ & - \frac{C}{2} (n_1 + m_1) \rho(n_1, n_2; m_1, m_2) \\ & + C [(n_1 + 1)(m_1 + 1)]^{1/2} \rho(n_1 + 1, n_2; m_1 + 1, m_2) \\ & + [1 \leftrightarrow 2], \end{aligned} \quad (B1)$$

where A, B, C are the gain, saturation and cavity loss parameters respectively for either mode and

$$\begin{aligned} \mu(n_1, n_2; m_1, m_2) = & \left[ 1 + \frac{B}{2A} (m_1 + n_1 + m_2 + n_2 + 4) + \frac{B^2}{16A^2} \times \right. \\ & \left. \times (m_1 - n_1 + m_2 - n_2)^2 \right]^{-1} \rho(n_1, n_2; m_1, m_2). \end{aligned} \quad (B2)$$

This equation for the density matrix can be translated into an equivalent equation for the coherent-state representation  $P(\epsilon_1, \epsilon_2)$  via the relation

$$\begin{aligned} \rho(n_1, n_2; m_1, m_2) = & \int P(\epsilon_1, \epsilon_2) e^{-|\epsilon_1|^2 - |\epsilon_2|^2} \times \\ & \times \frac{\epsilon_1^{n_1} (\epsilon_1^*)^{m_1} \epsilon_2^{n_2} (\epsilon_2^*)^{m_2}}{\sqrt{n_1! m_1! n_2! m_2!}} d^2\epsilon_1 d^2\epsilon_2. \end{aligned} \quad (B3)$$

The resulting equation for  $P(\epsilon_1, \epsilon_2)$  is

$$\begin{aligned} \dot{P} = & -\frac{A}{2} \left[ \frac{\partial}{\partial \epsilon_1} \epsilon_1 + \frac{\partial}{\partial \epsilon_2} \epsilon_2 + \frac{\partial}{\partial \epsilon_1^*} \epsilon_1^* + \frac{\partial}{\partial \epsilon_2^*} \epsilon_2^* - 2 \frac{\partial^2}{\partial \epsilon_1 \partial \epsilon_1^*} - 2 \frac{\partial^2}{\partial \epsilon_2 \partial \epsilon_2^*} \right. \\ & \left. + \frac{B}{4A} \left( \frac{\partial}{\partial \epsilon_1} \epsilon_1 + \frac{\partial}{\partial \epsilon_2} \epsilon_2 - \frac{\partial}{\partial \epsilon_1^*} \epsilon_1^* - \frac{\partial}{\partial \epsilon_2^*} \epsilon_2^* \right) \right] M \\ & + \frac{C}{2} \left[ \frac{\partial}{\partial \epsilon_1} \epsilon_1 + \frac{\partial}{\partial \epsilon_2} \epsilon_2 + \frac{\partial}{\partial \epsilon_1^*} \epsilon_1^* + \frac{\partial}{\partial \epsilon_2^*} \epsilon_2^* \right] P \end{aligned} \quad (B4)$$

where

$$\begin{aligned} M = & \left[ 1 - \frac{B}{2A} \left( \frac{\partial}{\partial \epsilon_1} \epsilon_1 + \frac{\partial}{\partial \epsilon_2} \epsilon_2 + \frac{\partial}{\partial \epsilon_1^*} \epsilon_1^* + \frac{\partial}{\partial \epsilon_2^*} \epsilon_2^* \right) \right. \\ & - 2(2 + |\epsilon_1|^2 + |\epsilon_2|^2) + \frac{1}{16} \frac{B^2}{A^2} \left( \frac{\partial}{\partial \epsilon_1} \epsilon_1 + \frac{\partial}{\partial \epsilon_2} \epsilon_2 \right. \\ & \left. \left. - \frac{\partial}{\partial \epsilon_1^*} \epsilon_1^* - \frac{\partial}{\partial \epsilon_2^*} \epsilon_2^* \right) \right]^{-1} P \end{aligned} \quad (B5)$$

We now change the variables from  $\epsilon_i, \epsilon_i^*$  ( $i=1,2$ ) to  $\rho_i$  ( $i=1,2$ ),  $\theta$ , and  $\mu$  in accordance with Eqs. (23a) - (23d). It can then be shown, in a straightforward manner, that the diffusion constant is

$$D(\theta) = \frac{A}{4\bar{n} \left( 1 + \frac{2B}{A} \bar{n} \right)} \quad (B6)$$

In deriving Eq. (B6) we assumed  $\rho_1^2 = \rho_2^2 \cong \bar{n}$  and  $\bar{n} \gg 1$ . Since [9]

$$\bar{n} = \frac{A(A-C)}{2BC} \quad (B7)$$

it follows that

$$D(\theta) = \frac{C}{2\bar{n}} \quad (B8)$$

This result, which is independent of how far above threshold the laser is operating, is in agreement with the results of Kennedy and Swain [8].

## REFERENCES

1. M.O. Scully, Phys. Rev. Lett. 55, 2802 (1985).
2. W.W. Chow, M.O. Scully, and J. Stoner, Phys. Rev. A 11, 1380 (1975).
3. M.O. Scully and K. Druhl, Phys. Rev. A 25, 2208 (1982).
4. See, for example, C.M. Caves, K.S. Thorne, R.W.P. Drever, V.D. Sandberg, and M. Zimmermann, Rev. Mod. Phys. 52, 341 (1980).
5. J. Gea-Banachloche and M.O. Scully, Phys. Rev. A (in press).
6. M.O. Scully, M.S. Zubairy, and M.P. Haugen, Phys. Rev. A 24, 2009 (1981).
7. See, for example, M. Sargent III, M.O. Scully, and W.E. Lamb, Jr., Laser Physics (Addison-Wesley, Reading, Mass., 1974).
8. T.A.B. Kennedy and . Swain, J. Phys. B 17, L 751 (1984).
9. S. Singh and M.S. Zubairy, Phys. Rev. A 21, 281 (1980).

FIGURE CAPTIONS

Fig. 1 Energy level diagram for the Quantum Beat Laser.

Fig. 2 Random walk of the correlated electric field phasors of magnitudes  $\rho_1$  and  $\rho_2$  in the complex  $\mathcal{E}$ -plane.

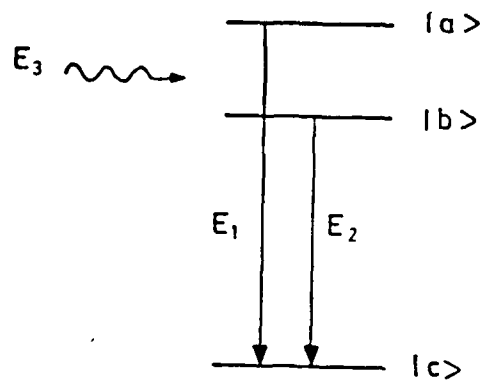

Fig 1:  
Scully & Zubairy

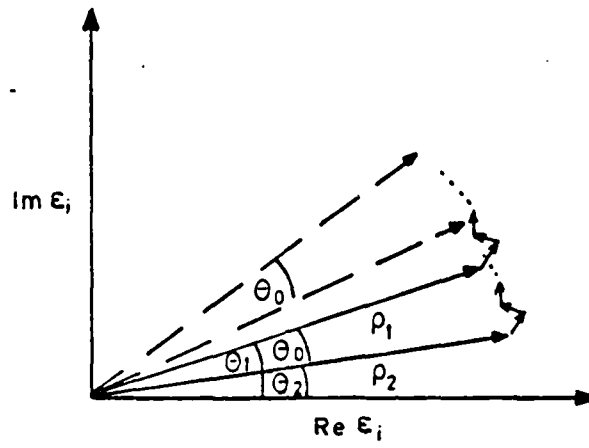

Fig 2:  
Scully & Zubairy

C

A PHYSICAL PICTURE FOR THE QUENCHING OF QUANTUM FLUCTUATIONS  
IN THE RELATIVE PHASE ANGLE IN THE QUANTUM BEAT LASER

Leno M. Pedrotti  
Center for Advanced Studies and Department of Physics and  
Astronomy, University of New Mexico, Albuquerque, NM 87131,  
U.S.A.

and

Marian O. Scully  
Max-Planck-Institute fur Quantenoptik, D-8046 Garching  
bei Munchen, West Germany.

Abstract. We provide a physical picture for the quenching of spontaneous emission noise between two laser fields which share the same, three-level, atomic medium but occupy different optical cavities. We call such a configuration a "quantum beat laser".

1. INTRODUCTION

It is well known that the laser has an intrinsic frequency linewidth due to spontaneous emission<sup>1-3</sup>. This finite linewidth is often responsible for limiting the sensitivity in certain types of experiments measuring changes in the resonant frequencies of optical laser cavities. Interferometers of this type include the ring laser gyroscope<sup>4</sup> and a new variety of proposed gravitational wave detector<sup>5</sup>. The expected change in resonant frequency induced by, e.g. gravitational radiation or the general relativistic Lense-Thirring effect<sup>6</sup> is so small that the spontaneous emission linewidth of the laser light could mask the signal.

In such experiments the frequency of a given laser is often inferred by beating the "signal" laser against another, stable "reference" laser. The electronic current produced by such a heterodyne scheme oscillates at the frequency difference of the two lasers and so can easily be resolved by conventional electronics. In the devices mentioned above, the frequency of the signal laser carries information concerning gravitational radiation

rotation rate, etc. If the random drift, due to spontaneous emission, of the laser frequency has a larger amplitude than the deterministic signal then no reliable information about the physical parameter of interest can be obtained.

In a recent paper we have shown that spontaneous emission noise in the relative phase can be made to vanish<sup>7</sup>. In this paper we provide a physical picture for this "quenching" of phase noise. In the quantum beat laser (see Figure 1) a lasing medium of three level atoms is prepared such that two of the atomic transitions (in the notation of Figure 1, the  $|a\rangle$  to  $|c\rangle$  and  $|b\rangle$  to  $|c\rangle$  transitions) drive a double resonant

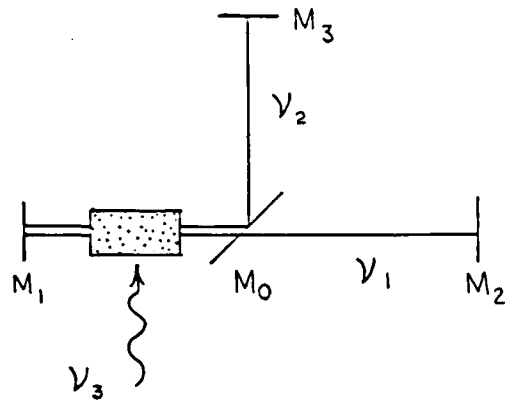

Fig.1(a)

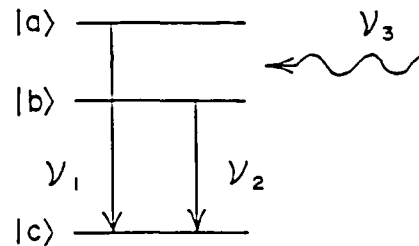

Fig.1(b)

Figure 1. (a) Laser consisting of three-level atoms coherently mixed by external microwave signal at  $\nu_3$ . Dichroic mirror causes light to be deflected in vertical direction for frequency  $\nu_2$  but transmits light at frequency  $\nu_1$ .

Figure 1. (b) Three-level atomic medium. Microwave signal,  $\nu_3$ , coherently mixes the upper,  $|a\rangle$  and  $|b\rangle$  levels.

laser cavity. These two laser fields are taken to oscillate with frequencies  $\nu_1$  and  $\nu_2$  respectively. By using such a doubly resonant cavity the two laser modes can be differentially affected by external

influences and yet, the noise in the relative phase angle between these modes can be quenched.

In the next section we discuss the model corresponding to the physical system shown in Figure 1. The equations which govern the mean value of, and spontaneous emission noise in, the relative phase angle between the two laser fields are also displayed and discussed in that section. Finally in section III a physical base for understanding this noise quenching is presented.

## II. THE QUANTUM BEAT LASER

In this section we present a more detailed description of the "quantum beat" laser shown in Figure 1. The central mirror,  $M_0$ , in the configuration is a dichroic mirror which transmits light of frequency  $\nu_1$  and reflects light of frequency  $\nu_2$ . In this way the transition between the atomic states,  $|a\rangle$ , and  $|c\rangle$ , can be used to drive a laser field of frequency  $\nu_1$  which occupies the cavity bounded by the mirrors  $M_1$  and  $M_2$ . Similarly the transition between the atomic states  $|b\rangle$  and  $|c\rangle$  can be used to drive a laser field of frequency  $\nu_2$  which occupies the cavity bounded by the mirrors  $M_1$  and  $M_3$ . The three level atomic medium is confined to the region bounded by the mirrors  $M_1$  and  $M_0$  and is fully illuminated by an external microwave field of frequency  $\nu_3$ , which is nearly resonant with the  $|a\rangle$  to  $|b\rangle$  atomic transition. It is this microwave field which prepares the  $|a\rangle$  and  $|b\rangle$  states into a coherent superposition which ultimately makes the noise quenching possible. Since the two cavity modes occupy two different cavities the beat note between the two modes could carry information concerning external effects (such as gravitational radiation) which change the two cavity lengths differentially. The details of how this system could be used to obtain information concerning the changing lengths of the two cavities is the subject of another series of papers.

In Reference [7] the quantum theory of such a two mode configuration was developed using the Langevin noise operator method. It was shown there that the phase diffusion, in the appropriate limit, could be made to

vanish. Specifically the equations which determine the mean evolution of, and the noise in, the relative phase were found to be,

$$\dot{\psi} = \delta\Omega - \gamma \sin \psi, \quad \text{"signal"} \quad (1)$$

and

$$D(\psi) = \frac{\gamma}{4\bar{n}} (1 - \cos \psi). \quad \text{"noise"}$$

where,  $\psi$  is the relative phase between the laser modes and the microwave field, and  $D(\psi)$  is the diffusion rate of this phase. Note that when  $\psi = 0$ ,  $D(\psi)$  vanishes. The parameters  $\gamma$  and  $\bar{n}$  are, respectively, the bandwidth of, and average number of photons in each segment of the doubly resonant cavity of Figure 1. The quantity,  $\delta\Omega$ , represents the difference in the cavity frequencies minus the microwave frequency. The relative phase has the specific form,

$$\psi = (\nu_1 - \nu_2 - \nu_3)t + \theta_1(t) - \theta_2(t) - \phi_{ab}, \quad (3)$$

where the quantities  $\theta_1(t)$  and  $\theta_2(t)$  represent the slowly varying phases of the lasing modes. The phase  $\phi_{ab}$  is the relative phase between the atomic levels  $|a\rangle$  and  $|b\rangle$  and in the present case is determined by the phase of the microwave field,  $\phi_\mu$ . The electromagnetic fields, corresponding to the two laser modes and the microwave field, respectively, would be represented classically as

$$E_1 = \epsilon_1 e^{-i\nu_1 t - i\theta_1(t)}, \quad (4a)$$

$$E_2 = \epsilon_2 e^{-i\nu_2 t - i\theta_2(t)}, \quad (4b)$$

and

$$E_3 = \epsilon_3 e^{-i\nu_3 t - i\phi_\mu}. \quad (4c)$$

The quantity,  $D(\psi)$ , given by Equation (2) is the diffusion rate of the relativistic phase angle  $\psi$  due to spontaneous emission. Equation (1) is the deterministic equation for the evolution of the mean value of  $\psi$ . For the present purposes it is sufficient to note that Equation (1) governs the deterministic behaviour of  $\psi$  and Equation (2) the noise in  $\psi$  due to spontaneous emission. Equation (1) implies  $\dot{\psi} \approx 0$  for small  $\delta\Omega$  and therefore, from Equation (2), the spontaneous emission noise,  $D(\psi)$ , vanishes. This is the "punch line". Indeed, so long as  $\delta\Omega \ll \gamma$ ,  $\psi$  reaches a steady state value given by

$$\psi_{ss} = \frac{\delta\Omega}{\gamma} \quad (5)$$

and the diffusion rate has the approximate value,

$$D(\psi) = \frac{\gamma}{4\bar{n}} \left( \frac{\delta\Omega^2}{2\gamma^2} \right) \quad (6)$$

which is drastically reduced from the spontaneous emission diffusion rate between two independent lasers which goes as  $\gamma/\bar{n}$ . To summarize: Equations (1) and (2) comprise our main point which is that the quantum mechanical diffusion rate,  $D(\psi)$ , for the relative phase in the quantum beat laser can be quenched when  $\dot{\psi} \approx 0$ .

### III. PHYSICAL DESCRIPTION FOR THE NOISE QUENCHING

It is our purpose here to provide a simple physical picture for understanding this vanishing of spontaneous emission noise in the relative phase. To this end, we consider the following two questions:

1. Why might one expect the noise in the relative phase could be quenched in a quantum beat laser?, and 2. Why must the phases of the two modes be locked to zero before the quenching becomes complete.

Concerning the first question we recall that in quantum beat experiments spontaneous emission events involving photons of frequencies  $\nu_1$  and  $\nu_2$  are correlated due to the preparation of a coherent superposition of upper atomic states,  $|a\rangle$ , and  $|b\rangle$ . A spontaneous emission event from

such an atom consists of a superposition of spontaneously emitted  $\nu_1$  and  $\nu_2$  photons. This is the so called quantum beat phenomenon<sup>8-10</sup>. That such a correlation is possible is demonstrated by the experimental observation of quantum beats<sup>11-14</sup>. A typical experiment set-up is depicted in Figure 2. Atoms are impulsively excited into a superposition of two closely spaced upper levels and a lower level by passage through

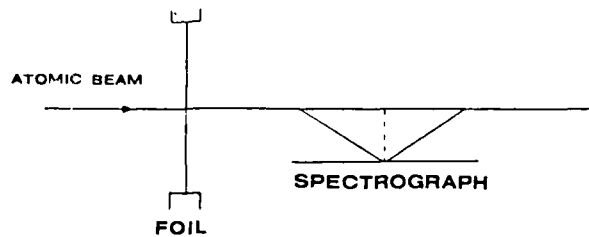

Figure 2. Experimental geometry and apparatus for a beam-foil type of quantum beat experiment.

a carbon foil. The light resulting from the decay of the upper levels is recorded by a spectrograph in such a way that spatial intensity variations in the spectrograph imply time-dependent oscillations (quantum beats) in the emitted light intensity. These quantum beats (which are observed in the light emitted from a single atom) imply a correlation between the spontaneously emitted photons from the two upper levels. As we shall see this correlation can be exploited to quench the noise in a relative phase between the two modes of a quantum beat laser.

This existence of correlated spontaneous emission can be argued on physical grounds as follows. Consider the state vector which describes the atoms of Figure 1(b),

$$|\psi\rangle = \alpha e^{-i\phi_a} |a\rangle + \beta e^{-i\phi_b} |b\rangle + \gamma e^{-i\phi_c} |c\rangle. \quad (7)$$

Equation (7) implies that the (semiclassical) spontaneously emitted fields would go as,

$$E_{1s} = \epsilon_1 e^{-i(\phi_a - \phi_b) - i\nu_1 t} \quad (8a)$$

and

$$E_{2s} = \epsilon_2 e^{-i(\phi_b - \phi_c) - i\nu_2 t}, \quad (8b)$$

where  $\epsilon \propto \alpha\gamma\chi_{ab}$  and  $\epsilon_2 \propto \beta\gamma\chi_{bc}$ , with  $\chi_{ab}$  and  $\chi_{bc}$  being matrix elements coupling the respective atom states via dipole interactions. The phases  $\phi_a$  and  $\phi_b$  of the upper atomic levels can be fixed by preparing the atoms in a coherent superposition of  $|a\rangle$  and  $|b\rangle$ . The phase of the lower level, however, is a random variable so that the average fields  $\langle E_1 \rangle$  and  $\langle E_2 \rangle$  vanish. However, this random phase,  $\phi_c$ , does not appear in the heterodyne cross term,

$$\langle E_1^* E_2 \rangle = \epsilon_1 \epsilon_2 e^{i(\phi_a - \phi_b) + i(\nu_1 - \nu_2)t} \quad (9)$$

which consequently, does not vanish.

Similar conclusions obtain when the field is quantized<sup>15</sup>. The fully quantized version of Equation (7) is,

$$|\psi\rangle = \alpha|a,0,0\rangle + \beta|b,0,0\rangle + \gamma_1|c,1,0\rangle + \gamma_2|c,0,1\rangle + \gamma_2|c,0,1\rangle \quad (10)$$

where the second and third "slots" in the kets on the right hand side of Equation (10) refer to the number states of the field containing photons with frequency  $\nu_1$  and  $\nu_2$  respectively. The expectation value of the electric field operator  $\hat{E}_1$ ,

$$\hat{E}_1 = \epsilon_1 \hat{a}_1 e^{i\vec{k}_1 \cdot \vec{r} - i\nu_1 t}, \quad (11)$$

is easily seen to vanish due to the orthogonality of the atomic states. However, as in the semiclassical treatment, the expectation value of the heterodyne cross term,

$$\langle \psi | E_1^+ E_2 | \psi \rangle = \epsilon_1^* \epsilon_2 \gamma_1^* \gamma_2 \langle c | c \rangle e^{-i(k_1 - k_2) \cdot \vec{r} + i(\nu_1 - \nu_2)t}, \quad (12)$$

does not vanish again showing that the spontaneously emitted photons at  $\nu_1$  and  $\nu_2$  are correlated in the sense that a spontaneous emission event from any given atom consists of a superposition of spontaneously emitted  $\nu_1$  and  $\nu_2$  photons.

This discussion shows that the spontaneous emission into the two modes of a quantum beat laser is correlated but, as per the second question we have provided no insight into the requirement that the relative phase (between the laser modes and the microwave field),  $\psi$ , must lock to zero before the noise due to spontaneous emission can be quenched completely. This last requirement is a result of the manner in which spontaneous emission causes a diffusion in the phase of a laser field. Before considering the problem of correlated spontaneous emission we briefly review spontaneous emission noise in an ordinary laser.

The effect of spontaneous emission on the phase of a laser field can be understood by considering Figure 3 which is a phasor diagram of the electric field vector for a laser. The length of the vector,  $\vec{E}$ , represents the amplitude of the laser field. The frequency of the laser field is represented by the rate at which the vector  $\vec{E}$  rotates about the origin. In Figure 3 the phasor diagram is drawn in a frame rotating with the laser frequency so that the vector  $\vec{E}$  is at rest (except for noise "jitter") relative to the x-axis. Hence the angle which  $\vec{E}$  makes with the x-axis represents the instantaneous phase,  $\theta$ , of the laser field. If not for spontaneous emission, the vector  $\vec{E}$  would be completely at rest in the rotating frame (corresponding to no drift in the laser phase) since all stimulated photons add to the field with the same phase. However, spontaneous emission occurs with random phase which leads to a drift in the laser phase. This process is depicted in Figure 3. The small vector,  $\vec{E}_s$ , represents a single spontaneous emission event which changes the laser field vector from  $\vec{E}$  to  $\vec{E}' = \vec{E} + \vec{E}_s$ . Since  $|\vec{E}'| \gg |\vec{E}_s|$  (and since the magnitude of  $\vec{E}$  is constrained by the laser's steady state operating condition) the dominant contribution which

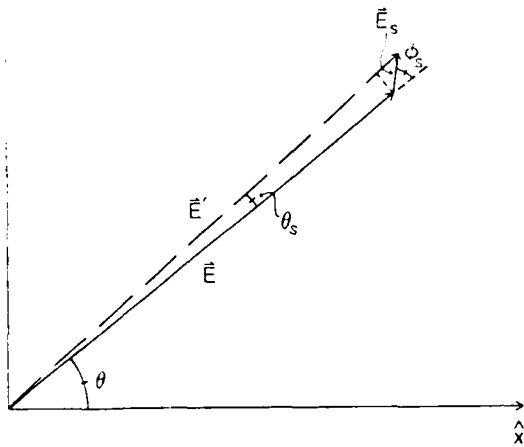

Figure 3. The vector  $\vec{E}$  represents the laser field.  $\vec{E}_s$  is the contribution due to a spontaneous emission event. Note that  $\vec{E}_s$  changes the phase of  $\vec{E}$  by an amount  $\theta_s$  when the angle between  $\vec{E}$  and  $\vec{E}_s$  is  $\phi_s$ .

spontaneous emission makes to the laser field is to change its phase. That is, only the portion of  $\vec{E}_s$  in quadrature with  $\vec{E}$  makes a significant contribution. From Figure 3 it is evident that the effect of this projection of  $\vec{E}_s$  perpendicular to  $\vec{E}$  is to change the phase of  $\vec{E}$  by an amount,

$$\theta_s = \frac{|\vec{E}_s|}{|\vec{E}|} \sin \phi_s, \tag{14}$$

where  $\phi_s$  is the relative phase between the laser field and the spontaneous emission event. Since spontaneous emission occurs with random phase,  $\theta_s$  has a vanishing average value. So, in order to make an estimate of the effect of many spontaneous emission events on the laser phase we consider the mean square contribution to the phase made by each event. Using Equation (14) we find

$$\overline{\theta_s^2} = \frac{|\vec{E}_s|^2}{|\vec{E}|^2} \sin^2 \phi_s = \frac{1}{2\bar{n}}. \tag{15}$$

In Equation (15) we have used the fact that ratio of the intensity of one spontaneous photon to that of the laser field is  $1/n$ . The diffusion rate,  $D_1$ , of the phase of the laser field can be interpreted as the rate at which the square of the uncertainty of the laser phase grows due to spontaneous emission events. Since  $\theta_s$  has zero mean,  $D_1$  can be written as,

$$D_1 = \frac{1}{2} \theta_s^2 \gamma = \frac{\gamma}{4n}, \quad (16)$$

where  $\gamma$  is the rate at which spontaneous photons exit the laser cavity<sup>16</sup>. This discussion gives a physical picture for the diffusion of the laser phase.

A similar phasor diagram adapted for the quantum beat laser can be used to demonstrate the necessity of locking the relative phase of the quantum beat laser modes to zero before correlated spontaneous emission will result in complete quenching of noise in the relative phase. In Figure 4,

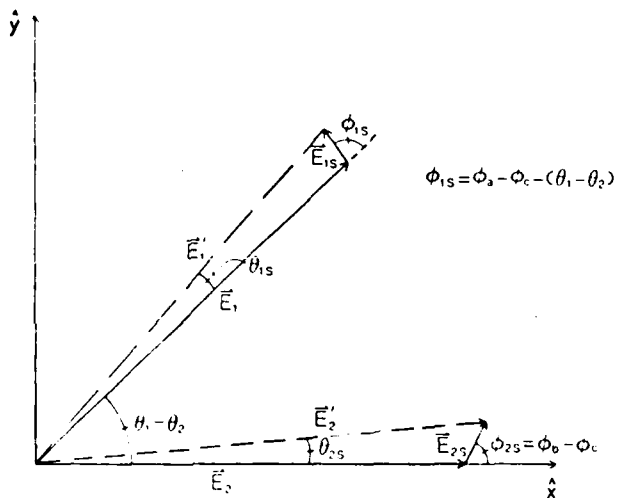

Figure 4. Contribution to the phases of fields,  $\vec{E}_1$  and  $\vec{E}_2$ , of a quantum beat laser due to a spontaneous emission event. When  $\theta_{1s} = \theta_{2s}$ , spontaneous emission does not change the relative phase,  $\theta_1 - \theta_2$ . This occurs only when  $\theta_1 - \theta_2 - (\phi_a - \phi_b) = 0$ .

the vectors  $\vec{E}_1$  and  $\vec{E}_2$  represent the two modes of the quantum beat laser (see Figures (4a) and (4b)). We consider the physical situation in which the laser modes are locked (but not necessarily locked to zero) so that the relative phase angle,  $\psi$ , (see Equation (3)) has the constant value,

$$\psi_0 = \theta_1 - \theta_2 - (\phi_a - \phi_b) . \quad (17)$$

The angles which  $\vec{E}_1$  and  $\vec{E}_2$  make with the x-axis of Figure 4 correspond to the phases of the two laser fields,  $\theta_1$  and  $\theta_2$  respectively. We will see that if  $\psi_0 = 0$ , then  $D(\psi_0)$  can be shown to vanish by a construction similar to that leading to Equation (16). A single spontaneous emission event makes the contributions  $\vec{E}_{1s}$  and  $\vec{E}_{2s}$  to the respective fields. In the following discussion we take, for simplicity, the magnitude of these vectors to be equivalent and also take  $|\vec{E}_1| = |\vec{E}_2|$ .

In the notation of Equations (7)-(9) the phases of the respective spontaneous contributions are  $\phi_a - \phi_c$  and  $\phi_b - \phi_c$ . Then, from Figure 4 we see that the angle between  $\vec{E}_1$  and  $\vec{E}_{1s}$ , and that between  $\vec{E}_2$  and  $\vec{E}_{2s}$ , are given respectively by,

$$\phi_{1s} = \phi_a - \phi_c - (\theta_1 - \theta_2) \quad (18a)$$

and

$$\phi_{2s} = \phi_b - \phi_c . \quad (18b)$$

These result in contributions to the overall phases of the laser fields of (compare to Equation (14)),

$$\theta_{1s} = \frac{|\vec{E}_{1s}|}{|\vec{E}_1|} \sin \phi_{1s} \quad (19a)$$

and

$$\theta_{2s} = \frac{|\vec{E}_{2s}|}{|\vec{E}_2|} \sin \phi_{2s} . \quad (19b)$$

In order that a spontaneous emission event does not contribute to the relative phase the condition  $\theta_{1s} = \theta_{2s}$  must be met. From Equations (18) and (19) we see that this condition is met if

$$\psi_0 = \theta_1 - \theta_2 - (\phi_a - \phi_b) = 0. \quad (20)$$

We have thus recovered, heuristically the requirement that the relative phase,  $\psi$ , must vanish in order that correlated spontaneous emission results in a complete quenching of the relative phase noise. In this case, the pair of vectors  $\vec{E}_1$  and  $\vec{E}_2$  "diffuse" together so that  $\theta_1 - \theta_2$  remains constant.

The precise form of the diffusion rate,  $D(\psi_0)$  of the relative phase for the general case ( $\psi_0 \neq 0$ ) can be obtained by defining (in analogy with Equation (14)),

$$D(\psi_0) = \frac{1}{2} \overline{(\theta_{1s} - \theta_{2s})^2} \gamma. \quad (21)$$

Using Equations (18) and (19) we write

$$(\theta_{1s} - \theta_{2s})^2 = \frac{1}{2n} \left[ \sin(\phi_a - \phi_c - \theta_1 + \theta_2) - \sin(\phi_b - \phi_c) \right]^2. \quad (22)$$

The factor of one half appearing in Equation (22) reflects the fact that each spontaneous emission event results in a contribution of "one half photon" of frequency  $\nu_1$  and "one half photon" of frequency  $\nu_2$  to the respective fields. A little trigonometric massaging transforms Equation (22) into

$$(\theta_{1s} - \theta_{2s})^2 = \frac{1}{n} (1 - \cos\psi_0) \cos^2 \left[ \frac{1}{2} (\phi_a + \phi_b - 2\phi_c - \theta_1 + \theta_2) \right]. \quad (23)$$

The last factor in Equation (23) has a mean value of one half since it contains the random variable,  $\phi_c$ , as an argument. Thus, by using Equation (23) in Equation (21) we find,

$$D(\psi_0) = \frac{\gamma}{4\bar{n}} (1 - \cos\psi_0) . \quad (24)$$

This is the same result as Equation (2) which was obtained via a detailed quantum noise calculation.

We note that, were it not for the microwave field which correlates the phases of the upper atomic levels, the angle,  $\psi_0$ , as given by Equation (17), would be a random variable. In this case  $\cos\psi_0 = 0$  and Equation (24) would take the value,  $D(\psi_0) = \gamma/4\bar{n}$ , which is precisely the result for the diffusion of the phase of an ordinary laser. This emphasizes the crucial role which the preparation of the upper atomic levels,  $|a\rangle$  and  $|b\rangle$ , plays in the quenching of the phase noise.

A brief summary of the arguments of this section: The noise in the relative phase between the two laser modes of the quantum beat laser can be made to vanish when the microwave pump field locks the phase of the two laser modes such that the correlated spontaneous emission noise adds to each laser mode in the same fashion and hence makes no net contribution to the relative phase. This argument is intended to suggest the basis of a physical understanding of the central results of the previous section (Equations (1) and (2)).

#### IV. CONCLUSIONS

In this paper we described a model which allows for the creation of two laser fields of different frequency which have vanishing spontaneous-emission-induced noise in their relative phase. Such a system may be of interest in new schemes for devices such as the ring laser gyro and a certain type of proposed gravitational radiation detector. Both systems depend on an accurate measurement of the relative phase between two laser fields and are fundamentally limited by the spontaneous emission drift in this relative angle.

## REFERENCES

1. Lax, M., In "Statistical Physics, Phase Transitions, and Superfluidity", ed. by M. Chretien et al., Gordon and Breach (1966) Vol. 2.
2. Haken, H., Handbuch der Physik, Springer Verlag (1970).
3. Sargent, M. III, Scully, M.O. & Lamb, W.E., Jr., Laser Physics, Addison-Wesley (1974).
4. See, for example, Chow, W.W. et al., Rev. Mod. Phys. 57, 61 (1984).
5. Scully, M.O. & Gea, J., to be published in Phys. Rev.
6. Scully, M.O., Zubairy, M.S. & Just, K., Phys. Lett. 77A, 88 (1980).
7. Scully, M.O., Phys. Rev. Lett. 55, 2802 (1985).
8. Chow, W.W., Scully, M.O. & Stoner, J., Phys. Rev. A11, 1380 (1975).
9. Grotch, H., Kornblith, R. & Eberly, J., Phys. Rev. A11, 1389 (1975)
10. Senitzky, J., Phys. Rev. Lett., 1755 (1975).
11. The pioneering work in quantum beat experiments was carried out by G. Series and co-workers. The authors thank W. Sandle for stimulating discussions in this regard.
12. Sellin, I.A. et al., Phys. Rev. Lett. 31, 1335 (1973).
13. Gaup, A., Andra, H.J. & Macek, J., Phys. Rev. Lett. 32, 268 (1974).
14. Bickel, W.S. & Bashkin, S., Phys. Rev. 162, 12 (1967).
15. This pioneering work in the quantum theory of photodetection was carried out by R.J. Glauber. A summary of this work is given in: R.J. Glauber in "Quantum Optics and Electronics" Les Houches Summer Lectures, ed. by C. DeWitt et al., Gordon and Breach (1965).
16. The factor of one half appearing in the definition of  $D_1$  is inserted to conform with the notation of Reference 7.
17. Strictly speaking there is no rotating frame in which both  $\vec{E}_1$  and  $\vec{E}_2$  are at rest since these vectors rotate at the frequencies  $\nu_1$  and  $\nu_2$  respectively. However in the case in which the relative phase angle locks, the difference between  $\nu_1$  and  $\nu_2$  is given by the constant, microwave frequency  $\nu_3$ . Thus we depict (in Figure 4) the vectors  $\vec{E}_1$  and  $\vec{E}_2$  as if they were at rest in the same frame when discussing the jitter in their relative phase.

Gravity Wave Detection via Correlated Spontaneous Emission Lasers



Marlan O. Scully and Julio Gea-Banacloche

Max-Planck-Institute fur Quantenoptik

D-8046 Garching bei Munchen

West Germany

and

Center for Advanced Studies and

Dept. of Physics and Astronomy

University of New Mexico

Albuquerque, NM 87131

Abstract

We show that, in principle, an active gravity wave detector based on a correlated spontaneous emission laser has potential advantages over the more usual passive scheme.

Work supported by the ONR and the AFOSR.

## I. INTRODUCTION

The current generation of laser interferometer gravity wave (g-wave) detectors<sup>1</sup> operate as passive phase-measuring devices, see Fig. 1a. In that figure a laser source drives two arms of an interferometer and the phase difference between the light propagating in these two arms is a measure of the intensity of the gravitational radiation. The shot noise limit of such a passive system yields a minimum detectable gravity wave given by

$$h_{\min}^{(p)} = \frac{\gamma}{\nu} \sqrt{\frac{\hbar\nu}{Pt_m}} \quad (\text{passive device shot noise limit}), \quad (1)$$

where  $\gamma$  is the cavity decay rate,  $\nu$  is the laser frequency,  $\hbar\nu$  is the energy per photon,  $P$  is the laser power and  $t_m$  is the measuring time.

On the other hand, putting the lasing medium inside the cavities as in Fig. 1b yields a much more favorable sensitivity to gravitational radiation in the shot noise limit. Such a device is said to be active because of the presence of an active medium inside the cavity. The shot-noise limited sensitivity of such a device is given by

$$h_{\min}^{(a)} = \frac{\omega_g}{\nu} \sqrt{\frac{\hbar\nu}{Pt_m}} \quad (\text{active device shot noise limit}), \quad (2)$$

where  $\omega_g$  is the gravity wave frequency.

The shot noise limit of the active system is interesting in that it is: (1) potentially more sensitive than the passive device, since  $\omega_g$  may be much smaller than  $\gamma$ ; (2) the envisioned device may be of laboratory (rather than kilometer) dimensions. In this context it is worth noting that a similar situation is encountered in ring laser gyro interferometry<sup>2</sup>. There when one makes a passive laser gyro device based on measuring the phase difference between the counter propagating waves (with the laser external to the Sagnac interferometer) long path lengths are required. This is accomplished by

winding a fiber optical wave guide many times around the perimeter of the optical circuit. On the other hand, gyros based on measuring the frequency difference (with the laser inside the optical cavity) between the counter-propagating laser beams do not require the many windings approach and achieve high sensitivity with modest optical paths.

However, as discussed below, the two-laser active interferometer device of Fig. 1b is limited not by shot noise, but by the spontaneous emission noise associated with each of the independent lasers of that figure. The phase fluctuations associated with spontaneous emission lead to a minimum detectable gravity wave of amplitude

$$h_{\min}^{(a)} \approx \frac{\gamma}{\nu} \sqrt{\frac{\hbar\nu}{Pt_m}} \quad (\text{active device spontaneous emission limit}), \quad (3)$$

i.e. the same limit as that associated with the passive device, Eq. (1).

In recent research associated with correlated emission lasers (CEL), e.g. the quantum-beat laser, it has been shown that uncertainty in the relative phase angle due to spontaneous emission can be eliminated. This device holds promise for a system in which the g-wave detector could operate as an active interferometer but without spontaneous emission noise. For such a system we find the sensitivity

$$h_{\min} \approx \epsilon \frac{\gamma}{\nu} \sqrt{\frac{\hbar\nu}{Pt_m}} \quad (\text{active detector based on CEL}), \quad (4)$$

where  $\epsilon$  is a function of  $\omega_g/\gamma$ . As discussed in Section IV,  $\epsilon$  is around  $10^{-2}$ , assuming reasonable values for  $\omega_g$  and  $\gamma$ .

It is the purpose of this paper to inquire as to whether a "correlated spontaneous emission" g-wave detector might in principle improve the active

system limit of Eq. (3). An example of such a scheme is offered herein. It is emphasized that there are many subtleties involving such a system, and the questions associated with measurement strategy for such a device require care in their analysis. It is hoped that this paper will provoke critical discussions, in particular concerning the extent to which such devices might be useful in future generation g-wave detectors. It is clearly worthwhile to investigate examples which challenge the accepted quantum noise "limits" and sharpen our understanding of these limits.

## II. PASSIVE VERSUS ACTIVE GRAVITY WAVE INTERFEROMETERS

For a gravity wave propagating in the x direction the correction to the metric from flat space time may be written<sup>3</sup> as

$$h_{uv}(x,t) = \begin{bmatrix} 0 & 0 & 0 \\ 0 & 0 & 0 \\ 0 & 0 & 1 \\ 0 & 0 & -1 \end{bmatrix} h(x,t) , \quad (5a)$$

where

$$h(x,t) = h_0 \cos(\omega_g t - k_g x) . \quad (5b)$$

In the above  $h_0$  represents the strength of the gravity wave,  $\omega_g$  its frequency and  $k_g$  its wave vector. From the covariant Maxwell equations we obtain a modified wave equation for an electromagnetic signal propagating in the y- and x-directions of Fig. 1. Noting that the gravity wave frequency is much smaller than the optical frequency we find

$$\frac{\partial^2 E_1}{\partial y^2} - \frac{1 + h(x,t)}{c^2} \frac{\partial^2 E_1}{\partial t^2} = 0 , \quad (6a)$$

$$\frac{\partial^2 E_2}{\partial x^2} - \frac{1}{c^2} \frac{\partial^2 E_1}{\partial t^2} = 0 . \quad (6b)$$

Equations (6a,b) lead to the following simple dispersion relations for the laser fields  $E_1$  and  $E_2$

$$k_1^2 - v_1^2(1 + h)/c^2 = 0 \quad , \quad (7a)$$

$$k_2^2 - v_2^2/c^2 = 0 \quad . \quad (7b)$$

We may view the above dispersion relations as implying a change in wave vector or frequency depending on whether the light source is taken as external or internal to the optical cavities under consideration. In the case of the laser external to the Michelson gravity wave detector (see Fig. 1a), Eqs. (7a) and (7b) yield

$$k_1 - k_2 = \frac{1}{2} \frac{v_1}{c} h_0 \cos(\omega_g t - k_g x_0) \quad , \quad (8)$$

while for the case of internal laser(s) (see Fig. 1b) the wave vector is viewed as constant and Eqs. (7a) and (7b) imply a frequency difference

$$v_1 - v_2 = \frac{1}{2} c k_1 h_0 \cos(\omega_g t - k_g x_0) \quad . \quad (9)$$

In the case of the passive device of Fig. 1a, the signal due to a gravity wave translates into a phase shift obtained from Eq. (8) by multiplying by the effective path length  $\tilde{L}$ , which is essentially the number of bounces times the length of the arm  $L_1$ . In this case the g-wave induced phase shift is given by  $\Delta\phi^{(p)} = 2\pi\tilde{L}h_0/\lambda$ . In such an experiment the fundamental quantum limit is given by "photon shot noise". Denoting the average number of laser photons by  $\bar{n}$ , the

power at the detector by  $P$  and assuming unit quantum efficiency for present purposes, one has the phase uncertainty due to shot noise for a measurement of duration  $t_m$

$$\Delta\phi_n = \frac{1}{\sqrt{n}} = [h\nu/Pt_m]^{1/2} . \quad (10)$$

Equating  $\Delta\phi^{(p)}$  to  $\Delta\phi_n$  one finds the minimum detectable g-wave amplitude for such a passive system to be

$$h_{\min}^{(p)} = \frac{\lambda}{2\pi L} \sqrt{\frac{h\nu}{Pt_m}} = \frac{\gamma}{v} \sqrt{\frac{h\nu}{Pt_m}} , \quad (11)$$

where we have introduced the cavity decay rate  $\gamma = c/\tilde{L}$ .

Consider next the active system of Fig. 1a. The tiny frequency separation given by Eq. (9) implies a phase difference accumulated during a time  $t_m$  of magnitude

$$\Delta\phi_g = \frac{v}{\omega_g} h_0 [\sin(\omega_g t_m - k_g x_0) - \sin k_g x_0] . \quad (12)$$

Now if we take the phase uncertainty to again be given by the shot noise limit, equating (10) to (12) the minimum detectable gravity wave due to this active configuration is found to be<sup>4</sup>

$$h_{\min}^{(a)} = \frac{\omega_g}{v} \sqrt{\frac{h\nu}{Pt_m}} \quad (\text{shot noise limit}) . \quad (13)$$

This result differs from the passive result of Eq. (11) in two ways. First the sensitivity is improved by the factor  $(\omega_g/\gamma)^{-1} \sim 10^3 - 10^4$ . Furthermore we note that the sensitivity of the passive device goes as  $\tilde{L}^{-1}$  and therefore large

systems are implied in order to reach maximum sensitivity. No such dependence accrues for Eq. (13). This suggests that the active system may involve only laboratory (meter) dimensions.

However in the analysis of an active device such as indicated in Figure 1b, we really have two independent lasers and there is therefore an additional source of frequency uncertainty due to the independent spontaneous emission fluctuations<sup>5</sup> of these two lasers. This implies an uncertainty in the frequency<sup>6</sup> between the two lasers of magnitude  $\Delta\nu(\text{spont.}) \approx \gamma\sqrt{\hbar\nu/Pt_m}$ . Equating this frequency error to the g-wave induced frequency difference given by Eq. (5) we find the spontaneous emission limit for the minimum detectable gravity wave signal

$$h_{\min}^{(a)} = \frac{\gamma}{\nu} \sqrt{\frac{\hbar\nu}{Pt_m}} \quad (\text{spontaneous emission limit}). \quad (14)$$

We see that this result is the same as that given above in Eq. (11) and therefore the two systems have an identical sensitivity and dependence on cavity length.

In recent studies stimulated by the above considerations, we have investigated a method for quenching spontaneous emission noise in the relative phase angle between two laser signals.<sup>7</sup> We found that the spontaneous emission linewidth and associated uncertainty of the difference frequency between two laser modes could be eliminated by preparing the laser medium in a coherent superposition of two upper states (via e.g., a microwave field coupling  $|a\rangle$  and  $|b\rangle$ ) as in quantum beat experiments, or by coherent pumping, as in the Hanle effect) as in Fig. 2. The heterodyne beat note of the radiation emitted from these states can, under the appropriate conditions, be freed from spontaneous emission noise. We here apply these considerations to the detection of

gravitational radiation. In the next section we develop the theory for such experiments and apply it to a possible experimental scheme.

### III. THEORY OF A CORRELATED SPONTANEOUS EMISSION G-WAVE DETECTOR

Consider the g-wave detector of Fig. 2. There we depict a quantum-beat/Hanle laser driving a doubly resonant cavity having frequencies  $\Omega_1$  and  $\Omega_2$ . The frequency  $\Omega_2$  is independent of the g-wave, while the other cavity mode frequency  $\Omega_1$  is dependent on the gravitational radiation according to the relation

$$\Omega_1 = \frac{n_1 \pi c}{2L_1} \left( 1 - \frac{1}{2} h_0 \cos(\omega_g t - k_g x_0) \right). \quad (15)$$

Now the heterodyne cross term may be written in terms of amplitude  $\rho_i$  and phase  $\theta_i(t)$  parameters as

$$\langle a_1^\dagger a_2 \rangle = \rho_1 \rho_2 \langle e^{-i\theta(t)} \rangle e^{-i(\nu_1 - \nu_2)t}, \quad (16)$$

where the relative phase difference  $\theta(t) = \theta_1(t) - \theta_2(t)$  undergoes random fluctuations due to spontaneous emission and  $\nu_i$ ,  $i = 1, 2$  is the actual lasing frequency of the  $i$ -th mode having amplitude  $\rho_i$ . It is expression (16) which is of interest experimentally since the frequencies appearing therein are dependent on the g-wave amplitude through Eq. (15).

As in Ref. 7 we define the overall phase angle  $\psi(t)$  as

$$\psi(t) = (\nu_1 - \nu_2 - \nu_3)t + \theta_1 - \theta_2 - \phi, \quad (17a)$$

$$\psi(t) = (\nu_1 - \nu_2)t + \theta_1 - \theta_2 - \phi, \quad (17b)$$

where Eq. (17a) is appropriate to the quantum-beat laser ( $\phi$  is the microwave-induced phase difference between atomic states  $|a\rangle$  and  $|b\rangle$  and  $\nu_3$  is the microwave frequency) and Eq. (17b) applies to the Hanle-effect laser, with  $\phi$  determined by the choice of pump-radiation polarization. It follows directly from Ref. 7 that the amplitudes  $\rho_i$ ,  $i = 1, 2$  and the phase angle  $\psi$  obey the equations of motion

$$\dot{\rho}_1 = \frac{1}{2}\alpha_{11}\rho_1 + \frac{1}{2}\alpha_{12}\rho_2 \cos\psi - \frac{1}{2}\gamma_1\rho_1 \quad , \quad (18a)$$

$$\dot{\rho}_2 = \frac{1}{2}\alpha_{22}\rho_2 + \frac{1}{2}\alpha_{21}\rho_1 \cos\psi - \frac{1}{2}\gamma_2\rho_2 \quad , \quad (18b)$$

$$\dot{\psi} = a - b \sin\psi \quad . \quad (18c)$$

In the above the linear gain and cross-correlation coefficients are given by  $\alpha_i = rg_i^2/\gamma_a^2$  and  $\alpha_{12} = \alpha_{21} = rg_1g_2/\gamma_a^2$  where  $r$  is the rate of excitation to state  $|a\rangle$ ,  $g_i$  is the atom-field coupling constant and  $\gamma_a$  is the atomic decay rate which we take as the same for all atomic levels. The cavity decay rates are denoted by  $\gamma_i$ ,  $a$  is given by Eq. (23), and the "locking" frequency  $b$  is given by

$$b = \frac{1}{2}\alpha_{12} \frac{\rho_1}{\rho_2} + \frac{1}{2}\alpha_{21} \frac{\rho_2}{\rho_1} \quad . \quad (19)$$

Finally, in Ref. 7 it was shown that the ensemble average of the heterodyne signal (16) can, in the appropriate limit, be written as

$$\langle \hat{a}_1^\dagger(t) \hat{a}_2(t) \rangle = \rho_1 \rho_2 e^{-D(\psi)t + i(\nu_1 - \nu_2)t} \quad (20)$$

where

$$D(\psi) = \frac{1}{16} \{ \alpha_1 / \rho_1^2 + \alpha_2 / \rho_2^2 - (\alpha_{12} + \alpha_{21}) e^{-i\psi} / \rho_1 \rho_2 \} + \text{c.c.} \quad (21)$$

The equations of motion (18a,b,c) and the phase diffusion coefficient  $D(\psi)$  as given by Eq. (21) provide a description of our coupled laser system. Let us consider the physically reasonable case of  $g_1 = g_2$  and  $\rho_1 = \rho_2$ ; then all  $\alpha$ 's reduce to a single rate,  $\alpha$ , and Eq. (21) assumes the simple form

$$D(\psi) = \frac{\alpha}{4\bar{n}} (1 - \cos\psi) \quad (22)$$

where  $\bar{n} = \rho_1^2 = \rho_2^2$ .

The other essential ingredient in our analysis is the equation of motion for  $\psi(t)$  provided by Eq. (18c). From Eqs. (15, 17) we see that the frequency,  $a$ , appearing in Eq. (18c) is given by

$$a = \Delta + \frac{1}{2} \nu_1 h_0 \cos(\omega_g t - k_g x_0) \quad (23)$$

where  $\Delta = \nu_1 - \nu_2 - \nu_3$  for the quantum-beat and  $\nu_1 - \nu_2$  for the Hanle-effect lasers. Note that  $\nu_1 - \nu_2 \approx \nu_3$  for the first and  $\nu_1 - \nu_2 = 0$  for the second.

#### IV. A MEASUREMENT STRATEGY

Now from Eq. (18c) we see that when  $a = 0$  the relative phase angle locks to the constant value  $\psi = 0$ . In this case  $D(\psi)$ , as given by Eq. (22), vanishes. We must now address the problem of extracting g-wave information while taking advantage of the "noise quenched" configuration occurring when  $D(\psi) = 0$ .

To this end consider the superheterodyne signal as per Fig. 3. Note that when we are locked the beat frequency contains no g-wave information but the relative phase angle  $\delta\psi$  is given by (see Appendix A)

$$\delta\psi = [\Delta + \frac{1}{2} v_1 h_0 \cos(\omega_g t - k_g x_0)]/b, \quad (24)$$

which does depend on the g-wave.

Thus when we are locked such that  $\Delta = 0$ , Eq. (24) yields

$$\delta\psi = \frac{1}{2} \frac{v_1}{b} h_0 \cos(\omega_g t - k_g x_0), \quad (25)$$

where we have noted that  $v_1 h_0/b \ll 1$  and are considering times  $t \ll \omega_g^{-1}$ .

Equating (25) to the shot noise error (10) we find

$$h_{\min} \approx \frac{b}{v_1} \sqrt{\frac{h\nu}{Pt_m}}, \quad (26)$$

and since in the above  $b = \alpha$  (compare Eq. (19)) this reduces to the familiar result given by Eq. (11), since  $\alpha \approx \gamma$ .

In order to improve the sensitivity, we introduce a mode-mode coupling designed to "reduce"  $b$ . In other words, we want a mode coupling that will result in the addition of a term  $c \sin\psi$  to the phase equation (18c). We do

this by injecting some light from one of the cavities into the other. To this end it is convenient to replace the resonator of Fig. 2 by two coupled ring cavities as in Fig. 4 and 5. The outside loops are necessary to be able to control separately the injection phases. Other schemes lead to a coupled-cavity problem which does not produce the  $c \sin \nu$  term in the phase equation (see Eq. (35c) below). This is discussed further in Appendix B.

Consider first the Hanle-laser system of Fig. 4. There we couple the (running wave) fields by taking the light which is transmitted through a mirror of one cavity, changing the polarization, and injecting it into the other cavity. This we do with an efficiency  $\kappa$ .

For the case of the quantum beat laser, we remove light from one cavity and inject it into the other while using a nonlinear element as a parametric frequency converter, see Fig. 5. The parametric process is described<sup>8</sup> by the interaction Hamiltonian

$$H_p = g \hat{a}_1^\dagger \hat{a}_2 \alpha_3 + g^* \hat{a}_1 \hat{a}_2^\dagger \alpha_3^* \quad (27)$$

where  $\alpha_3$  is the (classical) microwave field strength and  $g$  is the purely imaginary coupling constant  $g = i|g|$ . The equation of motion for the conversion process<sup>9</sup> is then given by

$$\frac{\partial \hat{a}_1}{\partial t} = |g| \alpha_3 \hat{a}_2 \quad (28a)$$

$$\frac{\partial \hat{a}_2}{\partial t} = - |g| \alpha_3^* \hat{a}_1^* \quad ; \quad (28b)$$

again we denote the conversion efficiency by  $\kappa$ .

In either the Hanle or quantum-beat case, we note that in coupling the field out of, say, cavity 2 we have

$$E_2(\text{out}) = t_3 E_2(\text{in}), \quad (29a)$$

where  $t_3$  is the transmission of mirror  $m_3$ , and passing through the polarization or frequency converter yields

$$\Delta E_1(\text{out}) = \kappa t_3 E_2(\text{in}) e^{-i\phi - i\delta_1}, \quad (29b)$$

where  $\Delta E_1$  is the field with the appropriate polarization or frequency generated with an efficiency  $\kappa$ . The phase shift along the outside loop is written as  $\phi + \delta_1$ , with  $\phi$  as in Eqs. (17). Finally we note that this couples into cavity 1 through mirror 4 to yield

$$\Delta E_1(\text{in}) = t'_4 t_3 \kappa \rho_2(\text{in}) e^{-i\theta_2 - i\phi - i\delta_1}, \quad (30)$$

where  $t'_4$  is the transmission coefficient of mirror 4 (going in). Now light is emitted from cavity 2 according to the round trip time  $\Delta t = c/p_2$ , where  $p_2$  is the perimeter of the second ring, so that

$$\frac{\Delta E_1}{\Delta t} = \frac{ct'_4 t_3}{p_2} \kappa \rho_2 e^{-i(\theta_2 + \phi) - i\delta_1} = \frac{1}{2} \gamma_{12} \rho_2 e^{-i(\theta_2 + \phi) - i\delta_1}, \quad (31)$$

where we have defined

$$\frac{1}{2} \gamma_{12} = \frac{ct'_4 t_3}{p_2} \kappa. \quad (32)$$

Similarly removal of field from cavity 1, frequency converting and injecting into cavity 2 leads to

$$\frac{\Delta E_2}{\Delta t} = \frac{1}{2} \gamma_{12} \rho_1 e^{-i(\theta_1 - \phi) + i\delta_2} \quad , \quad (33)$$

where now

$$\frac{1}{2} \gamma_{12} = \frac{ct_5 t_6'}{p} \kappa \quad . \quad (34)$$

The injection rates as given by Eqs. (31) and (33) alter the time evolution of the cavity amplitude and phases so that when  $\delta_1 = \delta_2 = \pi$  Eqs. (18a,b,c) become

$$\dot{\rho}_1 = \frac{1}{2} \alpha_1 \rho_1 + \frac{1}{2} \alpha_{12} \rho_2 \cos \psi - \frac{1}{2} \gamma_1 \rho_1 - \frac{1}{2} \gamma_{12} \rho_2 \cos \psi \quad , \quad (35a)$$

$$\dot{\rho}_2 = \frac{1}{2} \alpha_2 \rho_2 + \frac{1}{2} \alpha_{21} \rho_1 \cos \psi - \frac{1}{2} \gamma_2 \rho_2 - \frac{1}{2} \gamma_{21} \rho_1 \cos \psi \quad , \quad (35b)$$

$$\dot{\psi} = a - b \sin \psi + c \sin \psi \quad . \quad (35c)$$

Here  $\gamma_1$  represents the total loss rate of cavity 1, and  $\gamma_2$  that of cavity 2. The coupling mirrors  $m_4$  and  $m_5$  introduce losses in cavity 1 at a rate  $(1-r)c/p_1$  (where  $r = r_4, r_5$ ), so that one may write, for the amplitude loss rate  $\gamma_1/2$

$$\frac{1}{2} \gamma_1 = (1-r_4) \frac{c}{p_1} + (1-r_5) \frac{c}{p_1} + \frac{1}{2} \gamma_{\text{other}} \quad , \quad (36)$$

where  $\gamma_{\text{other}}$  represents any other losses for cavity 1. Eq. (36) assumes that  $r_4, r_5$  are real and positive. In this case, the reflection coefficients  $r_4', r_5'$ , for light of frequency/polarization 1 incident on the mirrors from the other side, must be equal in magnitude, but negative. The various transmitted and reflected waves at mirror 4 are shown in Fig. 6, assuming  $t_4' = t_4$ , real and positive, and taking into account the fact that  $\delta_1$  must equal  $\pi$  in order to have the correct sign for  $c$  in Eq. (35c). Note that, then, the light leaving the system at that mirror has amplitude

$$E_{\text{out}} = -r_4' t_3 E_2 e^{-i\phi} + t_4 E_1 = r_4 t_3 E_2 e^{-i\phi} + t_2 E_1 \quad (37)$$

(and frequency or polarization 1). This is important, as will be discussed later.

Let us now for simplicity assume that all the coupling mirrors have the same transmission and reflection coefficients, and that  $\rho_1 = \rho_2$ . We have then

$$c = \kappa \gamma_c \quad (38)$$

when  $\rho_1 = \rho_2$ , where  $\gamma_c$ , the loss rate for each cavity associated with the coupling mirrors ( $m_4$  and  $m_5$  for cavity 1,  $m_3$  and  $m_5$  for cavity 2) equals

$$\frac{1}{2} \gamma_c = 2(1-r) \frac{c}{p} \approx \frac{t^2 c}{p} \approx \frac{1}{2} \frac{\gamma_{12}}{\kappa} = \frac{1}{2} \frac{\gamma_{21}}{\kappa} \quad (39)$$

(compare with Eqs. (32) and (34)). The total loss rate  $\gamma$ , assumed again to be the same for both cavities, is then simply

$$\gamma = \gamma_c + \gamma_{\text{other}} , \quad (40)$$

as in Eq. (36).

Now we can see that Eq. (35c) gives the g-wave induced phase angle

$$\psi = \frac{1}{2} \frac{v_1}{b-c} h_0 \cos(\omega_g t - k_g x_0) , \quad (41)$$

(as shown in appendix A, this is true only if  $t \gg (b-c)^{-1}$ , and  $b-c \gg \omega_g$ ; however, Eq. (A.3) shows that Eq. (41) still gives the correct order of magnitude of  $\psi$  when  $b-c \sim \omega_g$  and  $t \sim 1/\omega_g$ .) The shot-noise limit (26) now reads

$$h_{\min} \approx \frac{\alpha - \gamma_c}{v} \sqrt{\frac{\hbar v}{P t_m}} , \quad (42)$$

since  $b-c = \alpha - \gamma_c$  when  $\rho_1 = \rho_2$  and  $\kappa = 1$ .

Now the question naturally arises "how small can  $\alpha - \gamma_c$  be?" From the results in Appendix A (with  $b$  replaced by  $\alpha - \gamma_c$ ) it may be seen that nothing substantial is gained by letting it be smaller than about  $\omega_g$ , if the measurement time  $t_m < \omega_g^{-1}$ . If indeed  $\alpha - \gamma_c \approx \omega_g$ , Eq. (42) becomes once again the active-device shot-noise limit of Eq. (2).

A problem arises, however, because, as a result of the phase-matching necessary to achieve our purposes, the light leaving the system (at mirrors  $m_4$  and  $m_5$  in Fig. 4) is in a superposition of modes 1 and 2 with a relative phase equal to  $\psi$ , which is very close to zero (see Eq. (37), and Fig. 6). They therefore interfere to give a "bright fringe" and under these conditions the very small phase difference  $\psi$  cannot be detected with the precision assumed in Eq. (42). This point is discussed further in Appendix C.

To be able to combine the fields  $E_1$  and  $E_2$  with a relative phase suitable for detection ( $\pi + \psi$  or  $\pm \pi/2 + \psi$ ; see Appendix C) we need to extract some

additional light from the cavity (indicated at mirrors  $m_7$  and  $m_8$  on Figs. 4,5) so that we can combine it with the appropriate relative phase. But any additional loss (beyond that associated with  $\gamma_c$ ) is going to require larger gain to bring the system above threshold, so that  $\alpha - \gamma_c$  will increase. Clearly, then, if we still want to have  $\alpha - \gamma_c \approx \omega_g$ , the losses introduced by the extraction of a "signal" beam must be kept small enough that one still has

$$\gamma - \gamma_c \approx \omega_g \quad , \quad (43)$$

where  $\gamma$  is the total loss rate for each cavity (including  $\gamma_c$  and the signal-beam extraction losses). As a result of this we find that the power in the signal beams  $P_s$  (coupled out at  $m_7, m_8$ ) is related to the actual power of the laser  $P_0$  (e.g., the power escaping at mirror  $m_4$ ) by

$$P_s = (\omega_g / \gamma) P_0 \quad . \quad (44)$$

It is this  $P_s$  that must be used for  $P$  in Eq. (42). The result is then seen to be of the form (4) with an  $\epsilon$  given by  $\epsilon = \sqrt{\omega_g / \gamma}$ ; i.e.

$$h_{\min} \approx \sqrt{\frac{\omega_g}{\gamma}} \frac{\gamma}{\nu} \sqrt{\frac{h\nu}{P_0 t_m}} \quad . \quad (45)$$

Thus if we assume  $\omega_g \sim 10^2$  and  $\gamma \sim 10^6$  we see that  $\epsilon \sim 10^{-2}$ . At this point we do not discount the possibility that a more efficient coupling mechanism might be found to reduce  $\epsilon$  even further. The important point is that  $\epsilon$  can be substantially less than unity. Some insight into the origin of the new limit (45) is provided in the following section.

## V. INTERPRETATION OF THE RESULTS

The new limit (45) has a simple interpretation in terms of the fundamental physics involved in the correlated spontaneous emission laser. Such a laser may be understood as actually operating in a single generalized mode of the radiation field when the relative phase angle  $\psi$  is locked to zero, i.e., in the absence of a gravitational wave. The gravitational wave may then be envisioned as exciting another mode (orthogonal to the original one), and detection of the gravity wave requires the detection of at least one photon in the new mode. This condition leads to the limit (45).

For definiteness, consider the Hanle-effect laser (similar results obtain for the quantum-beat laser). As before, we define annihilation operators associated with the modes of the two cavities as  $\hat{a}_1$  and  $\hat{a}_2$  (corresponding, for instance, to orthogonal linear polarizations), but when the locking condition  $\psi = 0$  is satisfied, the laser is effectively operating in the single mode

$$\hat{a}_+ = \frac{1}{\sqrt{2}} (\hat{a}_1 + e^{-i\phi} \hat{a}_2) \quad (46)$$

(which may correspond to circularly-polarized light, for example). In fact, from the semiclassical equations

$$\dot{E}_1 = \frac{1}{2}(\alpha - \gamma)E_1 + \frac{1}{2}\alpha e^{-i\phi} E_2 \quad , \quad (47a)$$

$$\dot{E}_2 = \frac{1}{2}(\alpha - \gamma)E_2 + \frac{1}{2}\alpha e^{+i\phi} E_1 \quad , \quad (47b)$$

and the definitions,

$$E_{\pm} = \frac{1}{\sqrt{2}} (E_1 \pm e^{-i\phi} E_2) \quad , \quad (48)$$

one proceeds, by multiplying Eq. (47.b) by  $e^{-i\phi}$  and adding (subtracting) the resulting equation to (47.a), to obtain

$$\dot{E}_{+} = \frac{1}{2}(2\alpha - \gamma) E_{+} \quad , \quad (49a)$$

$$\dot{E}_{-} = -\frac{1}{2}\gamma E_{-} \quad (49b)$$

(note that  $\phi$  is time-independent, being determined solely by the pumping mechanism to levels  $|a\rangle$  and  $|b\rangle$ , as mentioned in connection with Eq. (17.b)).

Equations (49) are decoupled, and in fact it may be shown that this decoupling holds also when nonlinear terms are taken into account, (i.e., when  $\alpha$  is the saturated gain). This will be shown in a later publication. Equations (49) also show that the mode  $E_{+}$  ( $\hat{a}_{+}$  in the quantum theory) is above threshold, while the mode  $E_{-}$  ( $\hat{a}_{-}$ ) is damped. The damping of  $E_{-}$  turns out to be equivalent to the locking of the phases  $\theta_1(t)$  and  $\theta_2(t)$  of  $E_{+}$  and  $E_{-}$  to the particular value  $\theta_1 - \theta_2 - \phi = 0$ . This may be seen as follows: from Eq. (48), we have

$$E_1 = (E_{+} + E_{-})/\sqrt{2} \quad , \quad (50a)$$

$$E_2 = e^{i\phi}(E_{+} - E_{-})/\sqrt{2} \quad (50b)$$

Then when  $E_- \rightarrow 0$  we are left with just

$$E_1(t) = E_+(t)/\sqrt{2} \quad , \quad (51a)$$

$$E_2(t) = e^{i\phi} E_+(t)/\sqrt{2} \quad , \quad (51b)$$

so that  $E_1(t) = E_2(t)e^{-i\phi}$ . This implies  $\rho_1 = \rho_2$  and  $\theta_1(t) = \theta_2(t) + \phi$ , or  $\psi = 0$ .

Also, one can see from this argument why when  $E_- = 0$  (i.e.,  $\psi = 0$ ) the relative phase diffusion due to spontaneous emission is zero. Equations (49) show that the atomic medium contributes gain to the  $E_+$  mode only. Therefore the spontaneous emission takes place only in this mode. The spontaneous  $E_+$  photons have of course a random phase, and will cause a random change in the phase of  $E_+(t)$ , but when Eqs. (51) apply this random phase change will be common to  $E_1(t)$  and  $E_2(t)$ ; hence the relative phase  $\theta_1(t) - \theta_2(t)$  will not change.

Consider now what happens in the presence of a gravitational wave. It will modify the frequency of mode 1, which may be represented by adding a term  $-ih(t)\nu E_1/2$  to the r.h.s. of Eq. (47a). This leads to the coupling

$$\dot{E}_+ = (\alpha - \frac{1}{2}\gamma - ih(t)\nu/2\sqrt{2})E_+ - ih(t)\nu E_-/2\sqrt{2} \quad , \quad (52a)$$

$$\dot{E}_- = -(\frac{1}{2}\gamma + ih(t)\nu/2\sqrt{2})E_- - ih(t)\nu E_+/2\sqrt{2} \quad . \quad (52b)$$

Since  $h_0 v \ll \alpha, \gamma, \omega_g$ , and  $|E_-| \ll |E_+|$  if we are never very far from the locked-in regime, the modifications to Eq. (49a) may be neglected, but Eq. (52b) will read

$$\dot{E}_- = -\frac{1}{2}\gamma E_- - ih(t)vE_+/\sqrt{2}, \quad (53)$$

which shows that the gravity wave acts as a source of photons in the "E<sub>-</sub>" mode. If we want to detect a signal proportional to  $\sin \psi$  (operation halfway between a dark and a bright fringe; see Appendix C) we will combine  $E_1$  and  $E_2$  at the detector in the form

$$e^{i\phi} E_1 E_2^* - E_1^* E_2 e^{-i\phi} = E_- E_+^* - E_-^* E_+. \quad (54)$$

Hence, in order to detect any signal at all, at least one photon of the "E<sub>-</sub>" type must reach the detector. The same is true for operation at a dark fringe (in that case the power at the detector is proportional to just  $|E_-|^2$ .) Suppose that all losses are transmission losses, so that the  $\gamma$  in Eq. (53) gives the rate at which the "E<sub>-</sub>" photons are leaving the cavity. Then we have

$$\dot{n}'_- = \gamma n_-, \quad (55)$$

where  $n'_-$  is the number of photons outside, and  $n_-$  the number of photons inside the cavity. If  $E_+$  in Eq. (53) is taken as constant, and the observation time is large enough compared to  $\gamma$ , one will get the steady-state result

$$E_- = \frac{-ihv}{\sqrt{2}\gamma} E_+ \quad (56)$$

or

$$n_- = \frac{h^2 \nu^2}{2\gamma^2} n_+ \quad (57)$$

When substituted in Eq. (55) this gives, over a measurement time  $t$ ,

$$n'_- = \frac{h^2 \nu^2}{2\gamma} n_+ t_m \quad (58)$$

for the number of " $E_-$ " photons reaching the detector. The condition that this number equals at least one gives

$$h_0 = \frac{1}{\nu} \sqrt{\frac{h\nu}{n_+ t_m}} \quad (59)$$

Now suppose that we may arrange for the  $E_+$  and  $E_-$  modes to have different decay rates, given by  $\gamma_+$  and  $\gamma_-$ . The nominal power of the laser is  $\gamma_+ n_+ h\nu$ , so we have

$$h_0 = \frac{1}{\nu} \sqrt{\gamma_+ \gamma_-} \sqrt{\frac{h\nu}{P_0 t_m}} \quad (60)$$

where we have noted that the  $\gamma$  that appears in Eq. (59) is now  $\gamma_-$ . Note that if  $\gamma_- \sim \omega_g$ , Eq. (60) gives the limit (45).

It is in fact possible to show, from a more careful analysis of the system (53) and (55), that the maximum signal is obtained when  $\gamma_- \sim \omega_g$  (the analysis above is an approximation valid only when  $\gamma_- \gg \omega_g$ ). To do this, one must actually integrate Eqs. (53) and (55), assuming a definite form for  $n(t)$ ; for instance, Eq. (5b).  $E_+$  in Eq. (53) may still be treated as approximately constant in steady state. Then  $E_-(t)$  is obtained by integrating Eq. (53), and used to obtain  $n_-(t)$ ; this is in turn substituted into Eq. (53) which is then

integrated between  $t = 0$  and  $t = t_m$  to give the total number of  $E_-$  photons leaving the cavity (and reaching the detector) in a time  $t_m$ . The calculation is straightforward, but lengthy; the result for  $n'(t_m)$  is

$$n'_- = \gamma_- \frac{h^2 v^2 n_+}{\gamma_-^2 + 4\omega_g^2} \left[ t_m + \frac{(\sin(2\omega_g t_m + 2\chi) - \sin 2\chi)}{2\omega_g} - (\cos \delta - e^{-\gamma_- t_m / 2} \cos(\omega_g t_m + \delta)) / \sqrt{\gamma_-^2 + 4\omega_g^2} + 2(1 - e^{-\gamma_- t_m}) \cos^2(\chi) / \gamma_- \right] \quad (61)$$

where  $\delta$  and  $\chi$  are unimportant phases. It is easy to see that, for given  $t_m$  and  $\omega_g$ , the factor  $\gamma_- (\gamma_-^2 + 4\omega_g^2)^{-1}$  is maximum when  $\gamma_- = 2\omega_g$ , and that the factor  $\gamma_- (\gamma_-^2 + 4\omega_g^2)^{-3/2}$ , occurring in the third term, is maximum when  $\gamma_- = \omega_g \sqrt{2}$ . As for the last term, it goes as  $(1 - e^{-2\gamma_- t_m}) / (\gamma_-^2 + 4\omega_g^2)$ , and it is maximum also around  $\gamma_- \sim \omega_g$  or  $1/t_m$ . Hence we see that  $n'$  is maximum when  $\gamma_- \sim \omega_g$ , in which case its order of magnitude is

$$n'_- \sim \frac{h^2 v^2 n_+ t_m}{\omega_g} \quad (62)$$

which is like Eq. (58) with  $\gamma(\gamma_-) = \omega_g$ . The limit (60), then, with  $\gamma_- = \omega_g$ , is seen to coincide with the result (45).

In effect, then, we may say that what the extraction-reinjection technique discussed here accomplishes is to make  $\gamma_+$  different from  $\gamma_-$ , and  $\gamma_- \sim \omega_g$ . This can also be seen directly from Eqs. (35), specialized to the case  $\alpha_1 = \alpha_2 = \alpha_{12} = \alpha_{21}$ ,  $\gamma_1 = \gamma_2 = \gamma$ ,  $\gamma_{12} = \gamma_{21} = \gamma_c$ ; for the complex amplitudes  $E_1, E_2$  one then has (in the absence of the gravity wave)

$$\dot{E}_1 = \frac{1}{2}(\alpha - \gamma)E_1 + \frac{1}{2}(\alpha - \gamma_c)e^{-i\phi} E_2 \quad (63a)$$

$$\dot{E}_2 = \frac{1}{2}(\alpha - \gamma)E_2 + \frac{1}{2}(\alpha - \gamma_c)e^{i\phi} E_1 \quad (63b)$$

Then, using the definition (48) again, one finds the equations for  $E_+$ ,  $E_-$ ,

$$\dot{E}_+ = \frac{1}{2}(2\alpha - \gamma - \gamma_c)E_+ \quad (64a)$$

$$\dot{E}_- = -\frac{1}{2}(\gamma - \gamma_c)E_- \quad (64b)$$

so that  $\gamma_+ \equiv \gamma + \gamma_c$ , and  $\gamma_- \equiv \gamma - \gamma_c = \gamma_{\text{other}} \sim \omega_g$ , as per Eqs. (40) and (43).

#### IV. CONCLUSIONS AND FINAL COMMENTS

In this paper we have discussed the passive and active-cavity approaches to interferometric detection of very small displacements. We have shown how, with an appropriate measurement scheme, a correlated spontaneous emission laser may be used to achieve a sensitivity surpassing (in principle) the conventional schemes.

We note in conclusion that the "nonlocal" or "tidal" nature of the g-wave interaction with the detector takes a very different form in passive and active devices. In the passive case the signal goes as

$$\Delta\psi^{(P)} = \frac{\gamma}{\lambda} h_0 \quad (65)$$

where  $\tilde{L}$  equals the number of bounces times the cavity length, whereas in the active scheme we have

$$\Delta\phi^{(a)} = \frac{v}{\omega_g} h_0 \quad (66)$$

Thus, for a passive device, it is clear that gravity wave detection is a nonlocal effect and measures deviations from Lorentzian spacetime only when  $\tilde{L}$  is appreciable. For an active detector the factor of  $\lambda/\tilde{L}$  is replaced by  $v/\omega_g$ . In this case the nonlocality is to be understood as a comparison of the g-wave amplitude at different points in spacetime, i.e. comparing the g-wave induced phase difference between detectors at different points in space, or comparing the phase shift of a single detector at different times. In this sense we are viewing the effect of the g-wave (according to Eq. (6a)) as leading to a kind of time-dependent "red shift". We recall that red shift experiments as carried out by Pound and Rebka involved the emission of radiation from nuclei localized at one point in space and the subsequent comparison with an absorber at another point in spacetime. In their experiment, we note that the atoms have vanishing physical extent as compared with the gravitational parameters, just as in our case the size of our "quantum beat g-wave detector" may be small compared to the gravitational wavelength  $\lambda_g$ .

Finally, we note that the largest useful  $\tilde{L}$ , as it appears in Eq. (65), is  $\lambda_g$ , and in that case

$$\Delta\phi^{(p)} = \frac{\lambda_g}{\lambda} h_0 \quad (\text{passive}) \quad (67)$$

But, since  $v = c/\lambda$  and  $\omega_g = c/\lambda_g$ , Eq. (66) may be written as

$$\Delta\phi^{(a)} = \frac{\lambda}{\lambda} h_0 = \frac{\lambda}{\lambda} h_0 \quad (\text{active}) \quad (63)$$

so that the active and passive phase shifts are seen to be the same in this limit.

#### ACKNOWLEDGEMENTS

This work sprang from seminal discussions with D. Anderson, R. Chiao, J. Ehlers, G. Leuchs, L. Pedrotti, W. Schleich, K. Thorne, and H. Walther. Useful communications are gratefully acknowledged with C. Caves, R. O'Connell, W. Sandle, A. Siegman, D. Walls, R. Weiss, and M. S. Zubairy. We are especially indebted to W. Sandle for a critical reading of the manuscript.

## APPENDIX A: CEL RESPONSE IN THE LOCKED REGIME

Consider the locking equation (18c) with  $a$  given by Eq. (23). By Eq. (19),  $b$  is of the order of magnitude of  $\alpha_{12}$ , which will be equal to  $\alpha$ , the gain rate; this in turn will be of the order of magnitude of  $\gamma$ , the cavity loss rate. Assuming that both the detuning  $\Delta$  and  $h_0\nu$  are much smaller than  $\gamma$  we have  $a \ll b$  (typical numbers might be  $\gamma \sim 10^6$  Hz for the cavity loss rate,  $\nu \sim 10^{15}$  Hz for the laser frequency and  $h_0 \sim 10^{-21}$  for the gravity wave). Then we expect the solution of Eq. (18c) to be very close to the stable steady-state solution that obtains when  $a = 0$ , namely,  $\psi = 0$ . Deviations of  $\psi$  from 0 will be of the order of  $a/b$ , so one may expand the sine function to first order, and obtain

$$\dot{\psi} = a(t) - b\psi . \quad (\text{A.1})$$

With the initial condition that  $\psi = 0$  (the steady-state solution in the absence of the gravitational wave) the solution to Eq. (A.1) is

$$\psi = \int_0^t e^{-b(t-t')} a(t') dt' . \quad (\text{A.2})$$

Substitution of Eq. (23) for  $a(t')$  gives

$$\begin{aligned} \psi(t) = \frac{\Delta}{b} (1 - e^{-bt}) + \frac{1}{2} \frac{\nu h_0}{b^2 + \omega_g^2} [b \cos(\omega_g t - k_g x_0) \\ + \omega_g \sin(\omega_g t - k_g x_0) - e^{-bt} (b \cos k_g x_0 - \omega_g \sin k_g x_0)] . \end{aligned} \quad (\text{A.3})$$

If the cavity decay rate  $\gamma$  is much larger than the frequency  $\omega_g$  of the gravitational wave we will have  $b \gg \omega_g$ , and it is easy to see then that Eq. (A.3) approaches Eq. (24) after a time  $t \gg 1/b$  (which may still be much smaller than one gravitational wave period). In this case, the phase of the field inside the cavity follows "instantaneously" the gravitational wave. The case in which the effective  $b$  is of the order of  $\omega_g$  is treated in detail in Section V.

#### APPENDIX B: RING CAVITIES VS. LINEAR CAVITIES

The transition from the system illustrated in Fig. 2 to the one presented in Figs. 4 and 5 may appear to involve a "quantum jump" in complexity, for which the motivation provided in the body of the paper may seem insufficient. We have explained how the system may be unlocked by extracting some light from one cavity and injecting it into the other one, and shown in detail how this works for our proposed cavity arrangement. What we wish to address in this Appendix is why we have chosen this particular arrangement (specifically, two ring cavities) to illustrate our scheme, rather than the linear "doubly-resonant" cavities of Fig. 2. The main reasons are as stated in Section IV, namely, to avoid feedback along the injection loops, and to retain control over the phase difference between the extracted and the injected signal (the  $\delta$ 's in Eqs. (29) - (33), which as discussed in the text, should be equal to  $\pi$ ). We will elaborate on these points here.

It may at first seem that the extraction-reinjection technique proposed in Section IV to reduce the locking might be used with the linear cavity of Fig. 2. In fact, with reference to e.g., Fig. 2b, assume that the top mirror is used to extract an amount of light from cavity 1 which is then rotated in polarization and injected into cavity 2 via the mirror on the right. If the

length of the path between the mirrors equals a half-integer number of wavelengths, the term added to the field  $E_2$  in cavity 2 is

$$\Delta E_2 = -t^2 E_1, \quad (\text{B.1})$$

every round trip, if both mirrors have amplitude transmission coefficients  $t$ . This may be seen by writing the standing-wave fields in both cavities as a sum of traveling waves and looking at how these traveling waves are coupled by the extraction and reinjection of light. In the same way, the same circuit would lead to an amount  $\Delta E_1 = -t^2 E_2$  being added to the field in cavity 1. This is actually more than is needed to unlock the system, since the cavity losses per round trip are only

$$(\Delta E)_{\text{loss}} = -(1-r)E = \frac{t^2}{2} E. \quad (\text{B.2})$$

This reasoning, however, fails for the following reason. When light from cavity 1 reaches the right-hand side mirror in Fig. 2, it is partly reflected and sent back on itself together with the transmitted field from cavity 2. What is then added to cavity 1 is not just some field from cavity 2, but a superposition

$$-t(tE_2 + rE_1). \quad (\text{B.3})$$

Again, some of this light will be reflected at the top mirror, and sent back to cavity 2. We find then that there is no simple way to estimate the magnitude - and, most importantly, the phase - of the field added to either cavity. In effect, we have set up a coupled-cavity problem, the solution of which is not

trivial; and it is not obvious that when equations of motion for  $E_1$  and  $E_2$  are written, that take into account the multiple reflections within the outside circuit (now a cavity in its own right), they will have the form that we want them to have.

Compared to this, we believe, it may be appreciated that the scheme illustrated in Figs. 4 and 5 has a greater conceptual simplicity, since (1) there is no possibility of feedback along the injection loops and (2) the phase-shift of the injected light may be easily controlled by choosing the optical path length of the injection loop.

Note that feedback appears to be unavoidable as long as we use the same mirror for extraction from, and injection into, a given cavity. One could easily think of schemes, based on the linear cavities of Fig. 2, with two separate injection loops, involving beam splitters, and one-way isolators to prevent feedback. The simplest of these schemes do not work, because they lead to losses larger than the coupling they provide; this is understandable intuitively, since light must be absorbed or otherwise lost at the one-way isolators.

We are still considering the coupled-cavity problem, and do not rule out the possibility that a useful coupling might be achieved in that case, but we believe that at the present time the scheme presented in this paper is the simplest "proof-of-principle" demonstration of our ideas. This point is argued further in Appendix D, which considers an alternative solution to the problem of how to extract the signal beams.

## APPENDIX C: THE OUTPUT FIELD.

We mention in the text that the field leaving the system at the mirrors  $m_4$  and  $m_c$  is not in a state useful for detection purposes. Since this is an important point it should be made as clear as possible.

Recall that the success of the extraction-reinjection "unlocking" technique requires that the injected field be out of phase by  $\pi$  radians relative to the phase difference with which the system tends to lock. That is, if the system, as indicated by Eq. (18.c) tends to lock at  $\psi = 0$ , the injected light should tend to lock the system at  $\psi = \pi$ . This results in phase relationships between the waves at, e.g., mirror 4 as shown in Fig. 6. There the phase of the cavity field (proportional to  $E_1$ ) relative to the injected wave is  $\theta_1 - \theta_2 - \phi - \pi = \psi - \pi$ . As a result of this, however, the output waves (bottom part of the beam splitter) have a phase difference of  $\psi$ . As shown in Eq. (37), the output field goes as

$$E_{\text{out}} = r_4 t_3 E_2 e^{-i\phi} + t_2 E_1 . \quad (\text{C.1})$$

where  $r_4$ ,  $t_2$ ,  $t_3$  are assumed real and positive for definiteness. The basic result discussed here does not arise from any particular choice of phase shifts at the beam splitter, but from general properties of (nonabsorptive) beam splitters; in particular, time reversal invariance requires  $r_4 = -r_4'$ .

The g-wave information is entirely contained in the phase difference  $\psi$ . We normally measure  $\psi$  by combining the fields  $E_1$  and  $E_2$  and looking at the interference term. The output field (Eq. (C.1)) contains both  $E_1$  and  $E_2$ , but their relative phase is such that they add almost in phase (since  $\psi \ll 1$ ). That is, on the outside of the mirrors  $m_4$  and  $m_c$  the beams interfere to give a "bright fringe". We emphasize that this results solely from the fact, pointed

out above, that on the opposite side of the beam splitter they must add "almost out of phase", i.e., with a phase difference  $\psi + \pi$ , for the "unlocking" mode coupling to be effective.

Essentially, then, to try to measure  $\psi$  by looking at the output of mirror 4 (or mirror 6) would be to look at a bright fringe, which is an unfavorable condition. Favorable conditions are at a dark fringe (beams combined with a phase difference  $\psi + \pi$ ) or halfway between bright and dark (beams combined with a phase difference  $\psi \pm \pi/2$ ). In the first case (dark fringe) the power at the detector would go like

$$P_{\text{det}} = 2P_0 (1 - \cos\psi) \approx P_0 \psi^2, \quad (\text{C.3})$$

(assuming equal power in both beams, for simplicity) while halfway between bright and dark one would have

$$P_{\text{det}} = 2P_0 \pm 2P_0 \sin\psi \approx 2P_0 \pm 2P_0 \psi. \quad (\text{C.4})$$

The first case has smaller photon counting noise and a smaller signal, the second one larger photon counting noise and a larger signal. If we write the equivalent photon counting power as

$$P_{\text{noise}} = \sqrt{P_{\text{det}} \frac{h\nu}{t_m}}, \quad (\text{C.5})$$

(if  $n = P_{\text{det}} t_m / h\nu$  is the total number of photons reaching the detector in the measurement time  $t_m$ , Eq. (C.5) is simply  $P_{\text{noise}} = \sqrt{n} h\nu / t_m$ ), we see that for the dark-fringe detector  $P_{\text{det}} \equiv P_0 \psi^2$ , so

$$P_{\text{noise}} = \psi \sqrt{\frac{P_0 \hbar \nu}{t_m}} ; P_{\text{signal}} = P_0 \psi^2 , \quad (\text{C.6})$$

while for the detector halfway between bright and dark fringes  $P_{\text{det}} \approx 2P_0$  (the dominant term) and so

$$P_{\text{noise}} = \sqrt{2P_0 \frac{\hbar \nu}{t_m}} ; P_{\text{signal}} = 2P_0 \psi . \quad (\text{C.7})$$

We see that Eqs. (C.6) and (C.7) give the same signal-to-noise ratio (aside from a factor  $\sqrt{2}$ ). On the other hand, at a bright fringe

$$P_{\text{det}} = 2P_0 (1 + \cos\psi) = 4P_0 - P_0 \psi^2 , \quad (\text{C.8})$$

so that

$$P_{\text{noise}} = 2 \frac{P_0 \hbar \nu}{t_m} ; P_{\text{signal}} = P_0 \psi^2 , \quad (\text{C.9})$$

which gives a much smaller S/N ratio than either Eq. (C.6) or Eq. (C.7), since  $\psi \ll 1$ .

The only way to combine  $E_1$  and  $E_2$  to obtain either a dark fringe or a half-fringe is then to extract some additional light from both cavities, since the light leaving the two output mirrors  $m_4$  and  $m_6$  is a superposition with the wrong phase difference ( $\psi$ , "bright fringe"). Hence the introduction of the beam splitters  $m_7$  and  $m_9$ . A possible alternative arrangement to operate on a dark fringe is discussed in the next Appendix.

## APPENDIX D: OPERATION AT A DARK FRINGE?

We have considered the possibility, for the Hanle-effect laser, of extracting the field from the cavity in a way that would not make use of the beam splitters  $m_7$  and  $m_6$  and would lead to operation "at a dark fringe" (see Appendix C). In this scheme (see Fig. 7), mirror  $m_1$  would be an ordinary 50/50 beam splitter. The polarization of the field in cavity 1 would be rotated just before it reaches  $m_1$ , to align it with the field in cavity 2, and the path lengths of both cavities would be chosen so that in the absence of a gravity wave one would have destructive interference (a dark fringe) between  $E_1$  and  $E_2$  at the "out" port of  $m_1$ ; that is, no net field would leave the cavity at  $m_1$ , and the field inside cavity 1 would change from  $E_1$  to

$$\frac{1}{\sqrt{2}} E_0 + \frac{1}{\sqrt{2}} E_2 e^{-i\phi} . \quad (\text{D.1})$$

Immediately behind  $m_1$ , a quarter-wave plate would convert this field to the appropriate circular polarization to interact with the gain medium. After passage through the gain medium, the beam would once again be split into its x and y polarization components at the dichroic mirror  $m_2$ .

With this arrangement no light would leave the cavity unless the phases of  $E_1$  and  $E_2$  were mismatched, so that the interference at the out port of the beam splitter were no longer entirely destructive. If a relative phase difference  $\psi$  developed, the output field would be proportional to

$$E_1 - E_2 e^{-i\psi} = \rho_1 e^{-i\theta_1} - \rho_2 e^{-i\theta_2 - i\psi} = -i\rho_2 e^{-i\theta_1} , \quad (\text{D.2})$$

AD-A173 103

THE CORRELATED EMISSION LASER - TOWARDS HIGH  
SENSITIVITY RING LASER GYROSC. (U) NEW MEXICO UNIV  
ALBUQUERQUE NM CENTER FOR ADVANCED STUDIES  
H O SCULLY EE AL. SEP 86 AFOSR-TR-86-0099

2/2

UNCLASSIFIED

F/G 20/5

NL



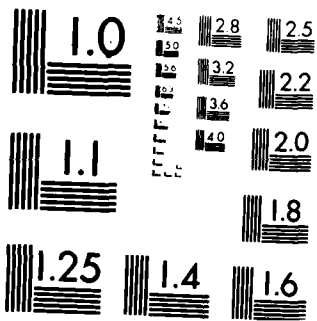

MICROCOPY RESOLUTION TEST CHART  
NATIONAL BUREAU OF STANDARDS 1963-A

if  $\rho_1 = \rho_2 = \rho$  and  $\psi = \theta_1 - \theta_2 - \phi$ . The total output power would therefore be proportional to  $\psi^2$ , as in the dark-fringe detection schemes discussed in Appendix C.

We have concluded, however, that this approach is not satisfactory for the following reason. Equation (D.1) implies a very strong coupling between the modes. The change in  $E_1$  in one round trip due to the beam splitter  $m_1$  would be

$$\Delta E_1 = \frac{1}{\sqrt{2}} E_2 e^{-i\phi} - \left(1 - \frac{1}{\sqrt{2}}\right) E_1 . \quad (D.3)$$

The first term leads to an equivalent mode-coupling coefficient

$$b' = \sqrt{2} \frac{c}{L} , \quad (D.4)$$

after dividing by the round trip time  $L/c$ . This is larger than the usual mode-coupling coefficient  $b$  (Eq. (19)) which, as discussed in the text, would be of the order of magnitude of  $2\gamma \sim t^2 c/L$ , where  $t$  is the mirror transmission. The phase difference between the modes  $E_1$  and  $E_2$  would lock to the value

$$\psi \sim \frac{1}{2} h\nu \frac{L}{c} , \quad (D.5)$$

which is smaller, by a factor  $t^2$ , than the usual locked result  $h\nu/2\gamma$ . Note that  $1/t^2$  is essentially the number of bounces. The strong coupling between the modes therefore reduces the size of the signal to that which would be obtained with just a single-pass cavity. Also, the locking coefficient is so large that our extraction-reinjection technique would be ineffective in trying to unlock it. We therefore conclude that this approach is not useful for our system, at least in the simple form discussed here.

## REFERENCES

1. For an early discussion of laser interferometer detection of gravitational radiation, see R. Weiss, Quarterly Progress Report, Research Laboratory of Electronics, MIT, 105; 54 (1972). For general background we have found the article by K. Thorne, Rev. Mod. Phys. 52, 285 (1980) to be helpful. A more up to date review of work at Cal Tech and Glasgow is described in the article of Drever, et al. and that of the Max-Planck Gravity Wave Group in the paper by H. Billing, et al. may be found in "Quantum Optics, Experimental Gravitation and measurement Theory", ed. by P. Meystre and M. Scully, NATO ASI Series, Vol. 94 (1983). For a review of recent optical g-wave detection work see the articles by C. Borde and coworkers, in Ann. de Physique 10, 201 (1985).
2. See for example: W. W. Chow, J. Gea-Banacloche, L. M. Pedrotti, V. E. Sanders, W. Schleich and M. O. Scully, Rev. Mod. Phys. 57, 61 (1985).
3. See for example, J. Weber, "General Relativity and Gravitational Waves" (Interscience Publishers, 1961), or "Gravitation" by C. Misner, K. Thorne and J. Wheeler (Freeman, San Francisco, 1973).
4. Considerations along these lines involving active detection have been put forth by N. Chebotayev and coworkers, see: S. Bagayev, et al., Appl. Phys. 25, 161 (1981).
5. See for example, M. Sargent III, M. O. Scully, and W. E. Lamb, Jr. Laser Physics (Addison-Wesley, Reading, MA 1974).
6. J. Gea-Banacloche, M. Scully and D. Anderson, Opt. Commun. (to be published).
7. M. Scully, Phys. Rev. Lett., 55, 2802 (1985).
8. See for example A. Yariv, Quantum Electronics, (Wiley 1967).

9. It has long been recognized that frequency conversion via parametric processes is free of quantum fluctuations. See for example W. Louisell, A. Yariv and A. Siegman, Phys. Rev. 124, 1646 (1961). For a more recent treatment see R. Graham, in "Quantum Optics", ed by S. Kay and A. Maitland (Acad. Press, 1970).
10. If we consider the quantization of the microwave field, then noise will accrue in the parametric process as well. In this case the noise in the microwave maser driving the quantum beam laser and the parametric converters would go as [maser intensity]<sup>-1</sup> and this could be made very small since the energy per photon is small. Reasonable estimates indicate that this noise could be made negligible on the scale of the present "experiment". On the other hand, the polarization converter used in the Hanle-laser case would clearly be noise free.

## FIGURE CAPTIONS

- Fig. 1a. Passive system: an external laser drives a Michelson interferometer which is influenced by an incident g-wave denoted by  $h_{\mu\nu}$ , traveling in the positive x direction.
- Fig. 1b. Active system: an incident g wave drives two independent lasers, which emit fields  $E_1$  and  $E_2$ . These fields are heterodyned in order to observe the temporal beat note.
- Fig. 2a. Quantum-beat-laser gravity-wave detector. Gravitational radiation perturbs frequency  $\Omega_1$  of doubly resonant cavity. Laser consisting of three level atoms coherently mixed by external microwave signal at frequency  $\nu_3$  drives cavities  $\Omega_1$  and  $\Omega_2$ . Dichroic mirror causes light to be deflected in vertical direction for frequency  $\nu_1$  but transmits light at frequency  $\nu_2$ .
- Fig. 2b. Hanle-effect-laser gravity-wave detector, similar to quantum beat system of Fig. 2a in that coherently excited atoms emit light of two polarizations which drives doubly resonant cavity via polarization sensitive mirror. Frequency of vertical arm is affected by gravitational radiation whereas horizontal laser radiation (copropagating with gravitational waves) is not affected by gravitational radiation.
- Fig. 3. Schematic illustration of experimental setup for quantum-beat laser. Radiation at  $\nu_1$  and  $\nu_2$  from quantum-beat laser influenced by g-wave is heterodyne detected by photomultiplier. The current at the beat-note frequency  $\nu_1 - \nu_2$  is superheterodyned with the external microwave signal at frequency  $\nu_3$ . The signal exiting the mixer is at frequency  $\nu_1 - \nu_2 - \nu_3$ . When gravity wave is present a small phase angle develops, as indicated in the figure.

Fig. 4. Running-wave Hanle-laser gravity-wave detector consisting of two coupled ring cavities. Lasing medium is common to both cavities. Mirrors  $m_1$  and  $m_2$  totally reflect polarization of cavity 1 and totally transmit polarization of cavity 2. Gravitational radiation incident from left influences frequency of cavity 1 whereas cavity 2 remains essentially unaffected. Running waves propagate in the indicated directions. Light of polarization 1 leaves cavity 1 at  $m_5$ , its polarization is changed and it is then partly coupled into cavity 2 via the mirror  $m_6$ . Similarly light is extracted from cavity 2 at the mirror  $m_3$ , polarization-rotated, and partly coupled into cavity 1 at mirror  $m_4$ . Mirrors  $m_7$  and  $m_8$  remove a small fraction of laser radiation for purpose of heterodyne detection.

Fig. 5. Figure illustrating the coupling of  $E_1$  and  $E_2$  via parametric frequency conversion in order to increase system sensitivity in quantum beat system. Analogous to Fig. 4 except that now light is frequency-upshifted or downshifted in the outside loops, and the mirrors  $m_1, m_2$  discriminate between frequencies rather than polarizations.

Fig. 6. Incident, reflected and transmitted waves at mirror  $m_4$ . Note that one must have  $r'_4 = -r_4$ . A similar picture is obtained at mirror  $m_6$ , in Figs. 4 and 5.

Fig. 7. A possible scheme for operation at a dark fringe. Part (a) of the figure shows the arrangement to be used in the inset (dashed box) shown in (b). The optical elements in (a) are as follows: A. polarization rotator by  $90^\circ$ .  $m_1$ , ordinary 50/50 beam splitter. B. quarter-wave plate. C. gain medium.  $m_2$ , polarization-sensitive mirror.

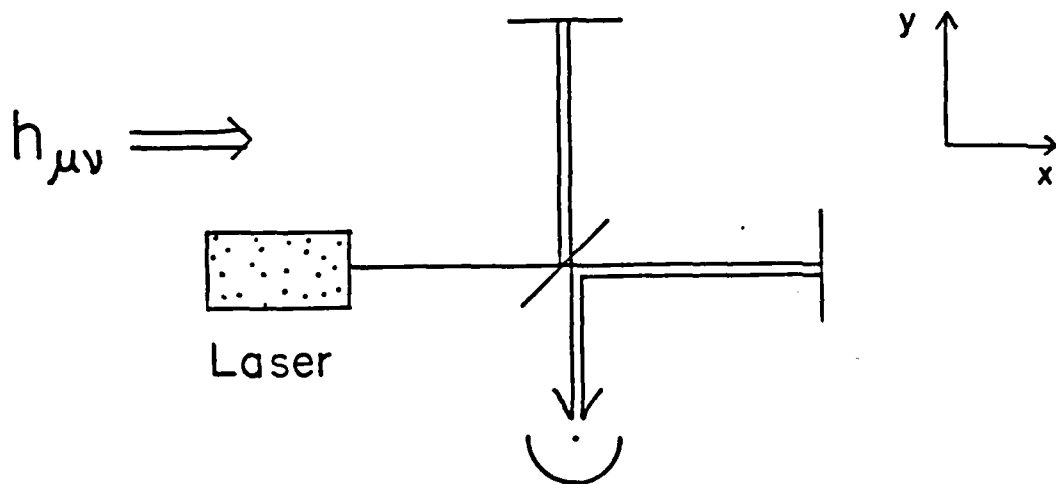

$$E_1^* E_2 = E_0^2 e^{ikLh}$$

(a) Passive Detection

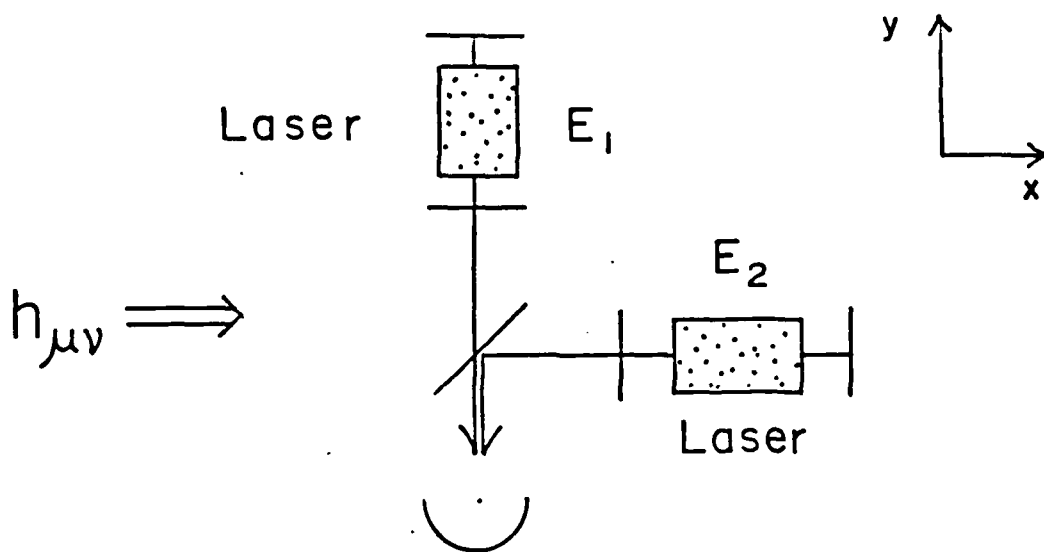

$$E_1^* E_2 = E_0^2 e^{i\nu h / \omega_g}$$

(b) Active Detection

# Quantum Beat Laser

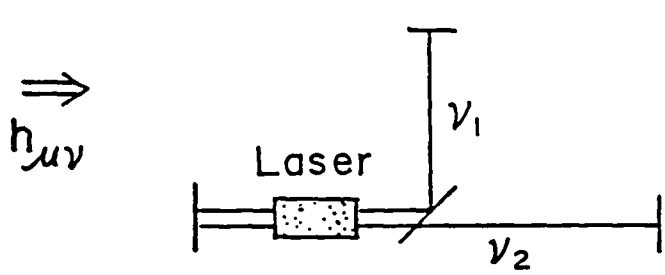

Doubly Resonant Cavity

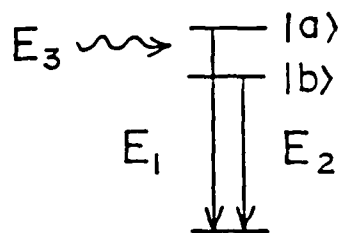

Microwave Induced Coherence

(a)

# Hanle Effect Laser

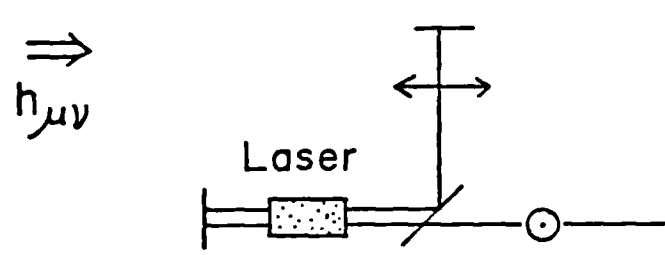

Doubly Resonant Cavity

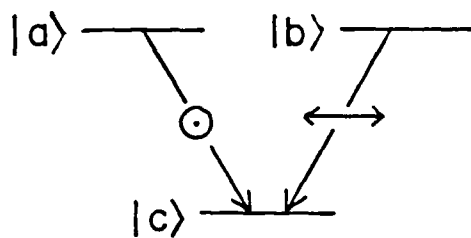

Polarization Induced Coherence

(b)

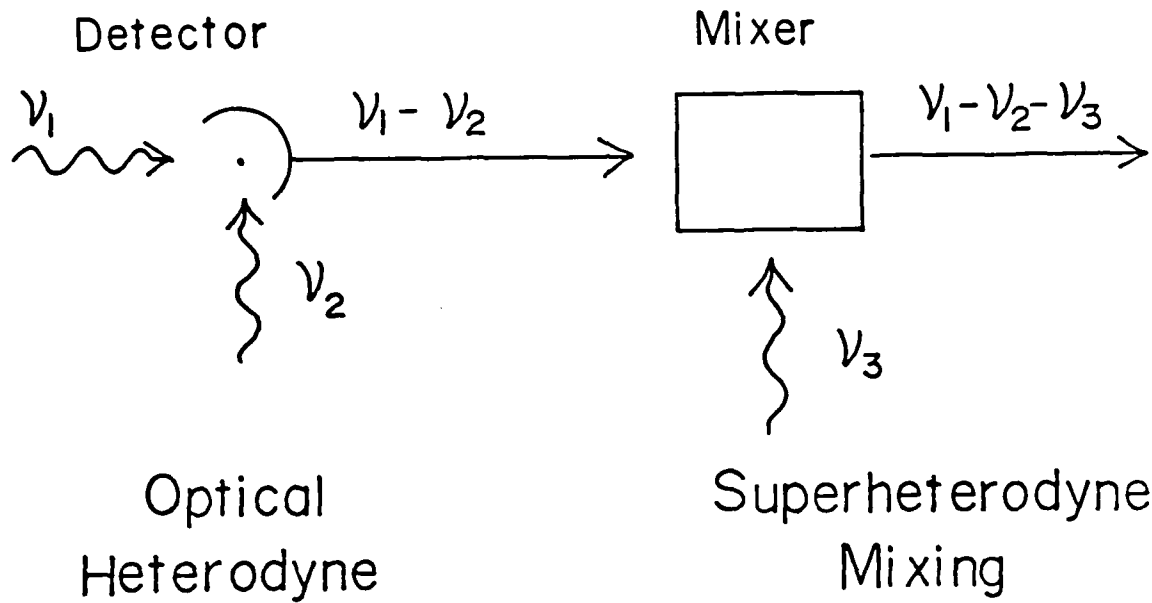

No Gravity Wave

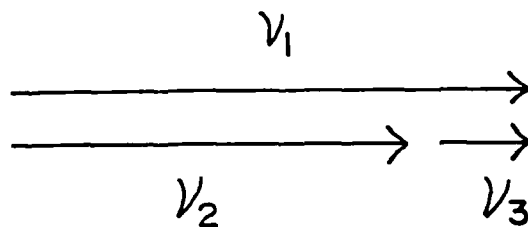

Gravity Wave

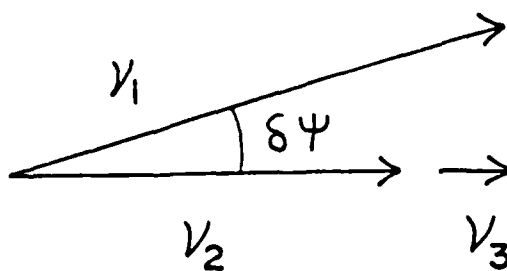

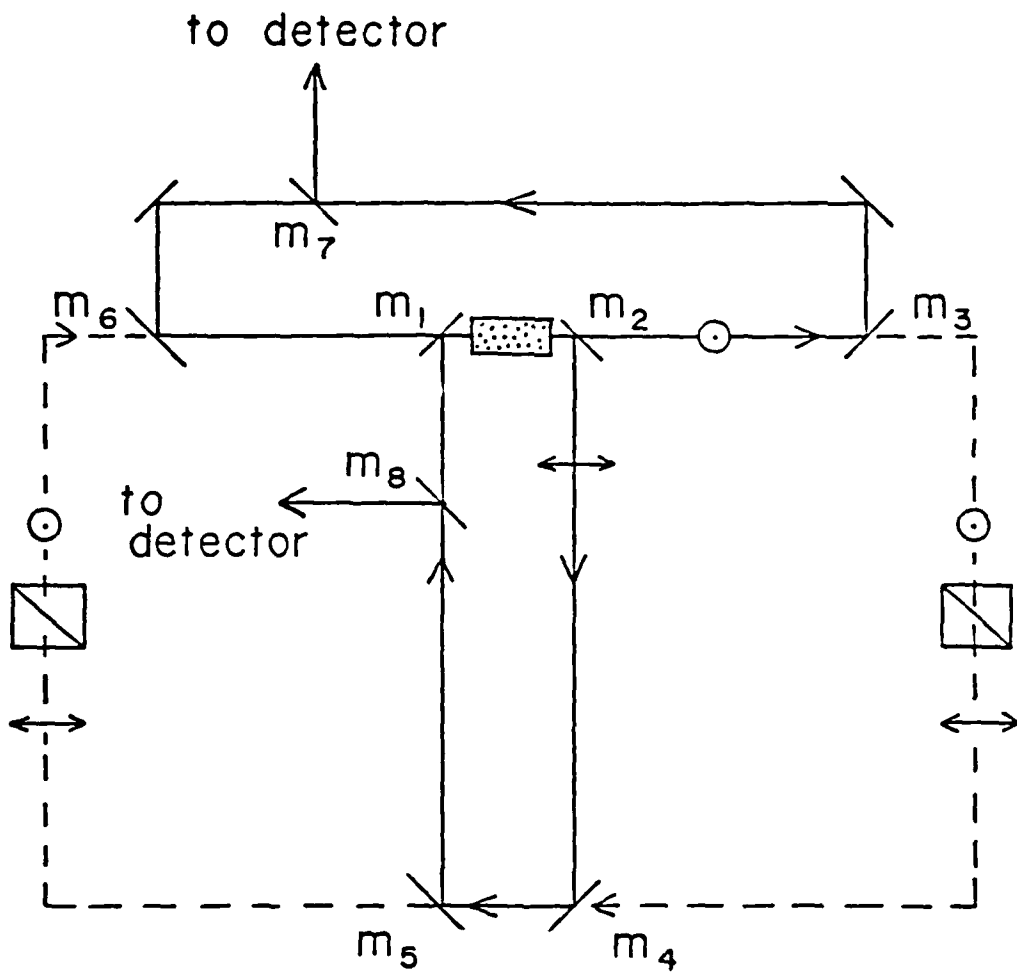

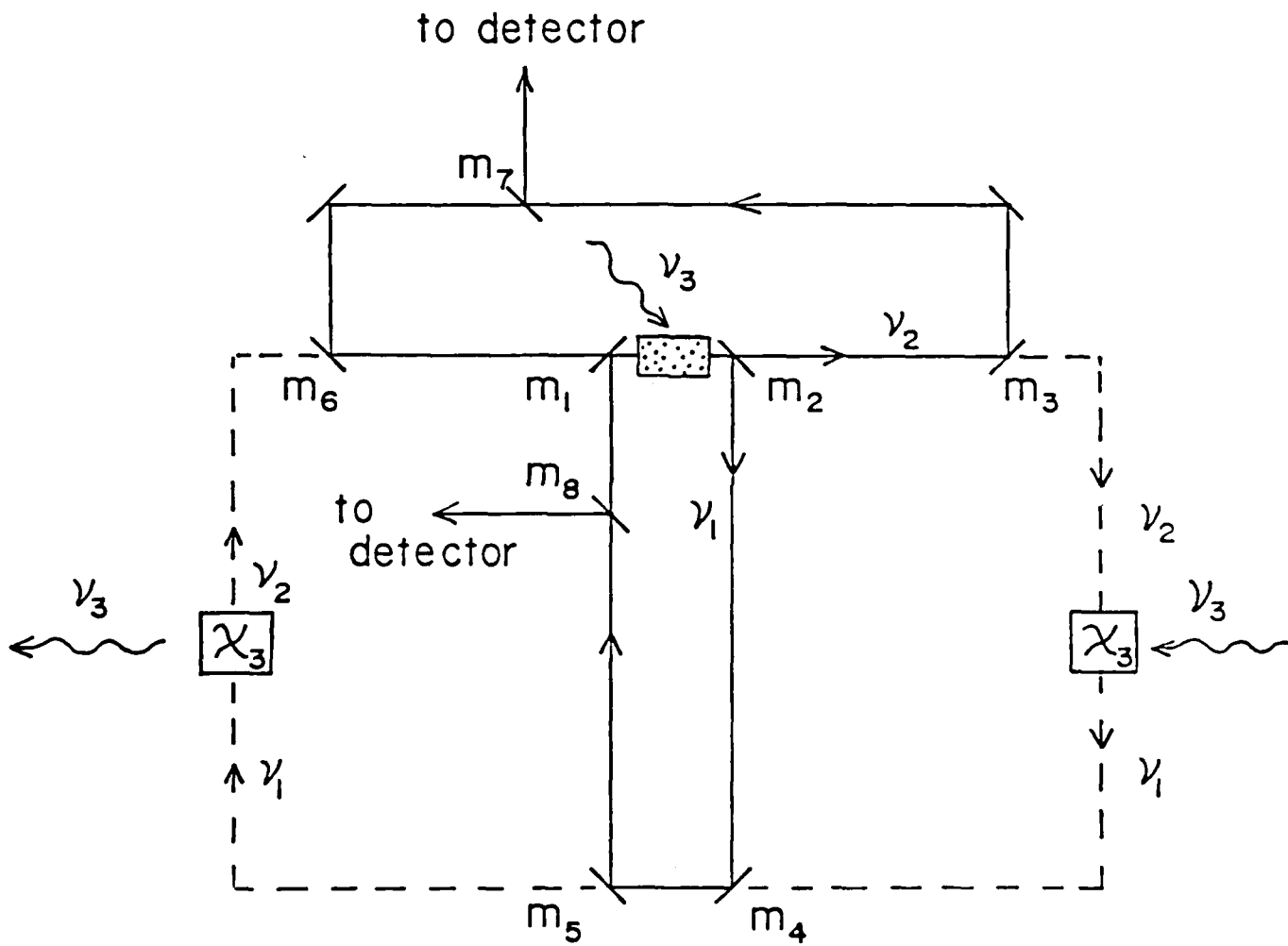
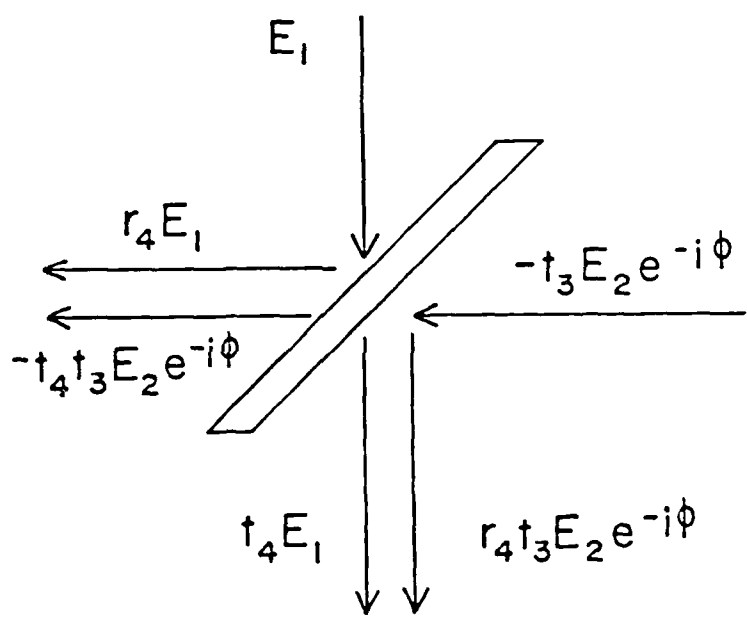
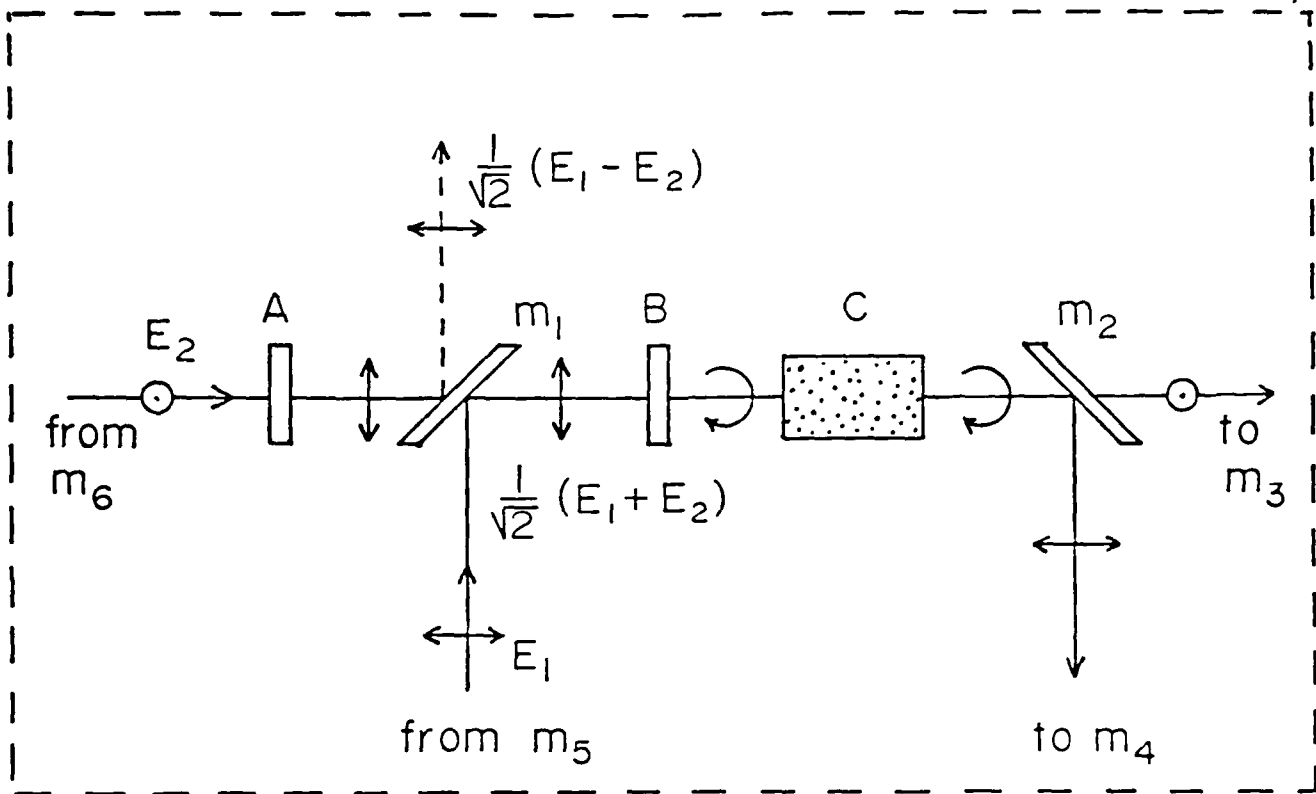
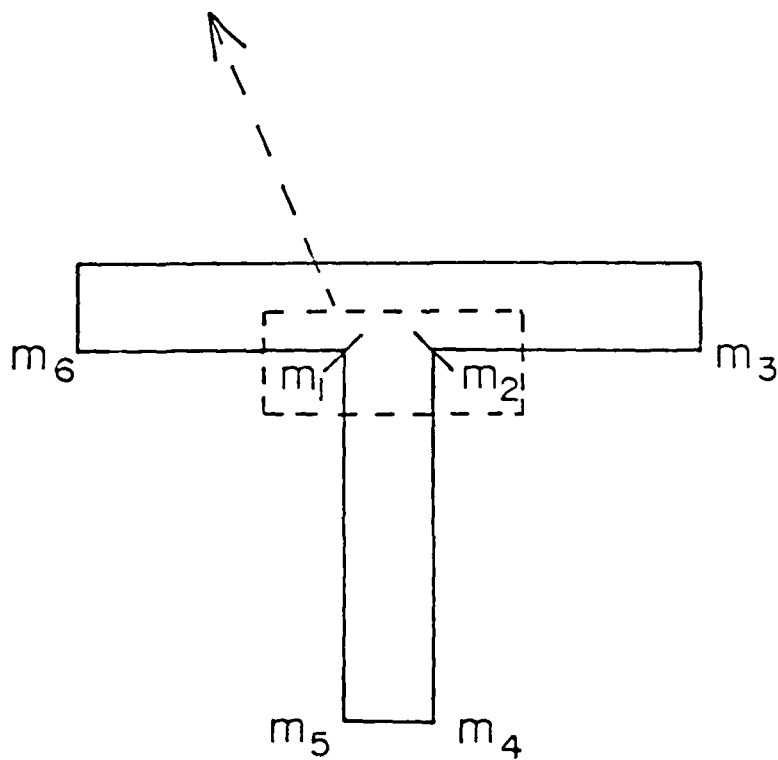

Fig. 5. ... P 3038





(a)



(b)

(E)

EPRB and the Wigner Distribution for Spin 1/2 Particles

Marlan O. Scully\*

Center for Advanced Studies  
and  
Department of Physics and Astronomy  
University of New Mexico, Albuquerque, NM 87131  
and  
Max-Planck Institut fur Quantenoptik  
D-8046 Garching bei Munchen  
West Germany

and

Leon Cohen

Hunter College of the City University  
New York, New York 10021  
and  
Center for Advanced Studies  
University of New Mexico, Albuquerque, NM 87131

Abstract

It is shown that the Wigner distribution for spin 1/2 particles provides a different perspective to the EPRB problem.

\* Work supported by the AFOSR and the ONR.

In recent work we have applied Wigner type quasi-probability distributions theory to the problem of spin 1/2 systems.<sup>1,2,3</sup> We here relate those results to the Einstein, Podolsky, Rosen Bohn (EPRB) problem. The (EPRB) "experiment" may be summarized or epitomized by asking: What is the probability for simultaneous passage of both spin partners through Stern-Gerlach apparatus (SGA) at angles  $+\theta_\alpha$  and  $-\theta_\beta$  respectively? If the state of the spin singlet is denoted by  $|\psi\rangle$  then this is clearly given by

$$P^{(2)}(+\theta_\alpha, -\theta_\beta) = |\langle +\theta_\alpha | \langle -\theta_\beta | \psi \rangle|^2$$

$$= \langle \psi | +\theta_\alpha \rangle \langle -\theta_\beta | \psi \rangle = \langle \psi | \pi(+\theta_\alpha) \pi(-\theta_\beta) | \psi \rangle, \quad (1)$$

where

$$\pi(\theta_i) = |\theta_i\rangle \langle \theta_i| = \frac{1}{2} (1 + \sigma(\theta_i)) \quad ; \quad i = \alpha, \beta \quad (2)$$

Since  $\pi(\theta_\alpha)$  and  $\pi(\theta_\beta)$  commute we may choose to write Eq. (1) in the symmetric form

$$P^{(2)}(+\theta_\alpha, -\theta_\beta) = \langle \psi | \frac{1}{2} [\pi(+\theta_\alpha) \pi(-\theta_\beta) + \pi(-\theta_\beta) \pi(+\theta_\alpha)] | \psi \rangle. \quad (3)$$

Taking  $|\psi\rangle$  to be in an antisymmetric "S" state Eq. (3) yields the usual result:

$$P^{(2)}(+\theta_\alpha, -\theta_\beta) = \frac{1}{4} (1 - \cos(\theta_\alpha - \theta_\beta)). \quad (4)$$

Next we ask: what do we get if we naively extend Eq. (3) to one particle physics? To answer this we calculate:

$$P_{+-}^{(1)}(+\theta_1, -\theta_2) = \langle \psi | \frac{1}{2} [\pi(+\theta_1) \pi(-\theta_2) + \pi(-\theta_2) \pi(+\theta_1)] | \psi \rangle \quad (5)$$

where 1 and 2 signify two arbitrary spin directions for the single particle. After a little algebra, Eq. (5) reduces to

$$P_{+-}^{(1)}(+\theta_1, -\theta_2) = \frac{1}{4} [1 + \langle \sigma_1 \rangle - \langle \sigma_2 \rangle - \cos(\theta_1 - \theta_2)], \quad (6)$$

and likewise we find

$$P_{-+}(-\theta_1, +\theta_2) = \frac{1}{4} [1 - \langle \sigma_1 \rangle + \langle \sigma_2 \rangle - \cos(\theta_1 - \theta_2)]. \quad (7)$$

where the state information appears only in  $\langle \sigma_1 \rangle$  and  $\langle \sigma_2 \rangle$ .

Now we see that if we take the average of (6) and (7) we find the usual EPRB result

$$\frac{1}{2} (P_{+-} + P_{-+}) = \frac{1}{4} (1 - \cos(\theta_1 - \theta_2)) \quad (8)$$

Thus we see that the incoherent average of the single particle "joint passage" expression, Eq. (8), equals the EPRB simultaneous passage probability Eq. (4).

But what is the physical and/or mathematical meaning of  $P^{(1)}(\pm\theta_1, \mp\theta_2)$  as given by Eqs. (6,7)? We give two answers to this question as follows:

A. Wigner joint count probability for spin 1/2:

As discussed in detail elsewhere<sup>1</sup> we define

$$P^{(1)}(s_1, s_2) = \frac{1}{4\pi^2} \iint e^{-i\xi s_1 - i\tau s_2} M(\xi, \tau) d\xi d\tau, \quad (9a)$$

where the characteristic function is

$$M(\xi, \tau) = \frac{1}{2} \langle e^{i\xi \sigma_1} e^{i\tau \sigma_2} + e^{i\tau \sigma_2} e^{i\xi \sigma_1} \rangle. \quad (9b)$$

Evaluating Eq. (9b) and inserting into (9a) as in Ref 1 we find

$$\begin{aligned} P^{(1)}(s_1, s_2) &= P_{++}(\theta_1, \theta_2) \delta(s_1 - 1) \delta(s_2 - 1) \\ &+ P_{+-}(\theta_1, \theta_2) \delta(s_1 - 1) \delta(s_2 + 1) \\ &+ P_{-+}(\theta_1, \theta_2) \delta(s_1 + 1) \delta(s_2 - 1) \end{aligned}$$

$$+ P_{--} (+e_1, +e_2) \delta(s_1 + 1) \delta(s_2 + 1) \quad (10)$$

where

$$P_{++} = \frac{1}{4} (1 + \langle \sigma_1 \rangle + \langle \sigma_2 \rangle + \cos \delta) \quad (11a)$$

$$P_{+-} = \frac{1}{4} (1 + \langle \sigma_1 \rangle - \langle \sigma_2 \rangle - \cos \delta) \quad (11b)$$

$$P_{-+} = \frac{1}{4} (1 - \langle \sigma_1 \rangle + \langle \sigma_2 \rangle - \cos \delta) \quad (11c)$$

$$P_{--} = \frac{1}{4} (1 - \langle \sigma_1 \rangle - \langle \sigma_2 \rangle + \cos \delta) \quad (11d)$$

and where  $\delta$  is the angle formed by directions 1 and 2.

We note that Eq. (10)-(11) may be written in the compact form

$$P^{(1)}(s_1, s_2) = \frac{1}{4} (1 + s_1 \langle \sigma_1 \rangle + s_2 \langle \sigma_2 \rangle + s_1 s_2 \cos \delta) \quad s_1, s_2 = \pm 1 \quad (12)$$

Thus, we see that  $P_{+-}^{(1)}$  and  $P_{-+}^{(1)}$  of eqs. (5,6) are just the joint probability distributions (11b) and (11c).

#### B. "Physical" interpretation for $P^{(1)}(\pm e_1, \pm e_2)$ :

Consider the state resulting from passing our particles (initially described by  $|\psi\rangle$ ) through a SGA tipped at angle  $\theta_1$  and accepting only those on the + path, this is given by

$$|+\theta_1\rangle\langle +\theta_1| \psi\rangle, \quad (13a)$$

and likewise the particles emerging on the - path of a SGA tipped at  $\theta_2$  is

$$|-\theta_2\rangle\langle -\theta_2| \psi\rangle. \quad (13b)$$

The overlap between (13a) and (13b) is

$$\langle \pi | -\theta_2 \rangle \langle -\theta_2 | +\theta_1 \rangle \langle +\theta_1 | \psi \rangle = \langle \psi | \pi(-\theta_2) \pi(+\theta_1) | \psi \rangle \quad (14)$$

Hence we see that, physically, the (symmetrized) overlap matrix element (14) is the same as Eq. (4).

In conclusion, we see that the two particle simultaneous passage probability  $P^{(2)}(\theta_1, \theta_2)$  of Eq. (4), is reproduced by the incoherent average of single particle joint quasi-distribution.

$$P^{(2)}(\theta_1, \theta_2) = \frac{1}{2} [P_{+-}^{(1)}(+\theta_1, -\theta_2) + P_{-+}^{(1)}(-\theta_1, \theta_2)] \quad (15)$$

The importance of coherent and incoherent mixtures in the EPRB problem has been stressed elsewhere.<sup>4</sup>

REFERENCES

1. L. Cohen and M. Scully, John A. Wheeler Festschrift, Foundations of Physics, to be published. See also M. Scully, Phys. Rev. D28, 2477 (1983).
2. We note that R. O'Connell and E. Wigner (Phys. Rev. 139, 21617 (1984) have studied the application of the Wigner distribution to many particle physics in which spin and statistics are important. That interesting problem is different in scope and direction from the present work. Also see H. Margenau and R. N. Hill, Prog. Theoret. Phys. 26, 722 (1961).
3. Related studies have been reported by W. Wootten and D. Mermin: This conference.
4. C. D. Cantrell and M. O. Scully, Physics Reports, 43, 499 (1978); M. O. Scully, R. Shea and J. D. McCullen, Physics Reports 43, 485 (1978).

END

12-86

DTIC