

AD-A173 360

FIELD TEST RESULTS OF ALUMINUM STANDING-SEAM ROOFING

1/1

(U) CONSTRUCTION ENGINEERING RESEARCH LAB (ARMY)

CHAMPAIGN IL M J ROSENFELD JUL 86 CERL-TR-M-86/14

UNCLASSIFIED

MIPR-81-938-16

F/G 13/13

NL

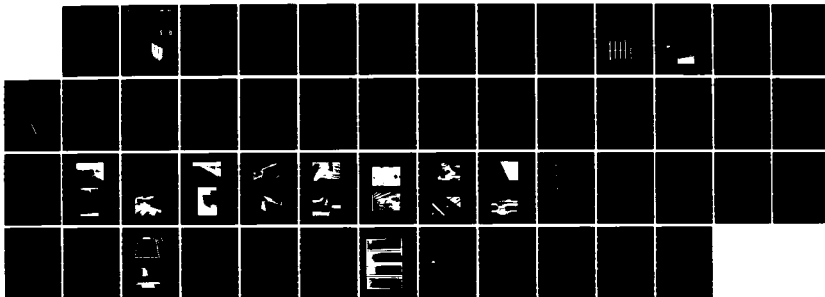

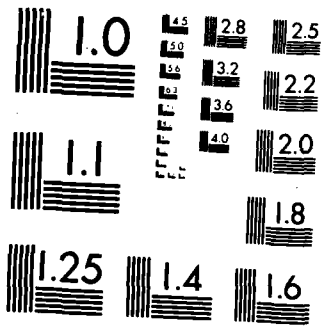

MICROCOPY RESOLUTION TEST CHART  
NATIONAL BUREAU OF STANDARDS-1963-A



US Army Corps  
of Engineers  
Construction Engineering  
Research Laboratory

AD-A173 360

USA-CERL

TECHNICAL REPORT M-86/14  
July 1986

# Field Test Results of Aluminum Standing-Seam Roofing

by  
Myer J. Rosenfield

DTIC  
ELECTE  
OCT 23 1986  
S D D

The overall objective of this project was to determine the behavior of aluminum standing-seam roofing over two annual cycles and to evaluate its capacity for long-term, trouble-free performance. The roofing system was installed on three warehouses at the Defense Construction Supply Center (DCSC) at Columbus, OH. Thermocouples and gage points were installed to measure surface and substrate temperatures, expansion, contraction, and lateral deflection. Measurements were taken at the time of installation and at 6-month intervals for the next 2 years. Data indicated the roofing system expanded and contracted without restraint, performing as expected. Temperature measurements also indicated that the system reacted to solar radiation and the ambient temperature as expected. Visual observations indicated that many important details of flashings and connections were deficient in design, fabrication, or both. These should be corrected for the system to function properly.

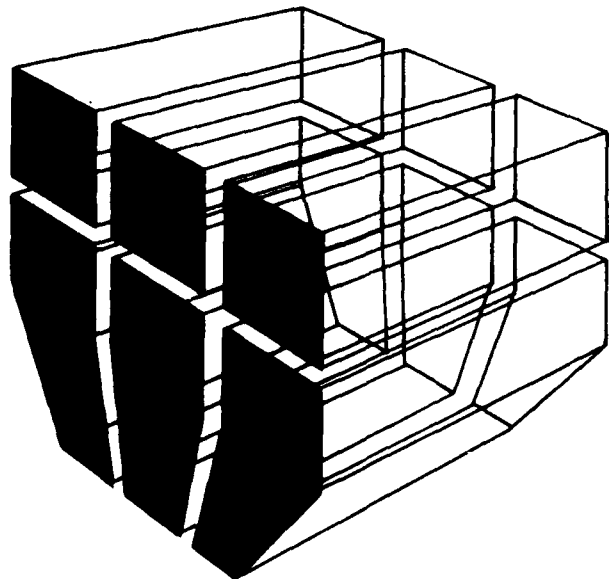

DTIC FILE COPY

Approved for public release; distribution unlimited.

49-10-40-0-2

The contents of this report are not to be used for advertising, publication, or promotional purposes. Citation of trade names does not constitute an official indorsement or approval of the use of such commercial products. The findings of this report are not to be construed as an official Department of the Army position, unless so designated by other authorized documents.

*DESTROY THIS REPORT WHEN IT IS NO LONGER NEEDED  
DO NOT RETURN IT TO THE ORIGINATOR*

UNCLASSIFIED

SECURITY CLASSIFICATION OF THIS PAGE (When Data Entered)

REPORT DOCUMENTATION PAGE		READ INSTRUCTIONS BEFORE COMPLETING FORM
1. REPORT NUMBER CERL TR M-86/14	2. GOVT ACCESSION NO. <b>ADA173360</b>	3. RECIPIENT'S CATALOG NUMBER
4. TITLE (and Subtitle) FIELD TEST RESULTS OF ALUMINUM STANDING-SEAM ROOFING	5. TYPE OF REPORT & PERIOD COVERED Final	
	6. PERFORMING ORG. REPORT NUMBER	
7. AUTHOR(s) Myer J. Rosenfield	8. CONTRACT OR GRANT NUMBER(s) MIPR 81-938-16	
9. PERFORMING ORGANIZATION NAME AND ADDRESS U.S. Army Construction Engr Research Laboratory P.O. Box 4005 Champaign, IL 61820-1305	10. PROGRAM ELEMENT, PROJECT, TASK AREA & WORK UNIT NUMBERS	
11. CONTROLLING OFFICE NAME AND ADDRESS Defense Logistics Agency Cameron Station Alexandria, VA 22314	12. REPORT DATE July 1986	
	13. NUMBER OF PAGES 50	
14. MONITORING AGENCY NAME & ADDRESS (if different from Controlling Office)	15. SECURITY CLASS. (of this report) UNCLASSIFIED	
	15a. DECLASSIFICATION/DOWNGRADING SCHEDULE	
16. DISTRIBUTION STATEMENT (of this Report) Approved for public release; distribution unlimited.		
17. DISTRIBUTION STATEMENT (of the abstract entered in Block 20, if different from Report)		
18. SUPPLEMENTARY NOTES Copies are available from the National Technical Information Service Springfield, VA 22161		
19. KEY WORDS (Continue on reverse side if necessary and identify by block number) roofs Defense Construction Supply Center, Columbus, OH aluminum		
20. ABSTRACT (Continue on reverse side if necessary and identify by block number) The overall objective of this project was to determine the behavior of aluminum standing-seam roofing over two annual cycles and to evaluate its capacity for long-term, trouble-free performance. The roofing system was installed on three warehouses at the Defense Construction Supply Center (DCSC) at Columbus, OH. Thermocouples and gage points were installed to measure surface and substrate temperatures, expansion, contraction, and lateral deflection. Measurements were taken at the time of installation and at 6-month intervals for the next 2 years. Data indicated the roofing system expanded and contracted without restraint, performing as expected. Temperature measurements also		

DD FORM 1 JAN 73 1473 EDITION OF 1 NOV 65 IS OBSOLETE

UNCLASSIFIED

SECURITY CLASSIFICATION OF THIS PAGE (When Data Entered)

UNCLASSIFIED

SECURITY CLASSIFICATION OF THIS PAGE(When Data Entered)

BLOCK 20 (Cont'd)

→ indicated that the system reacted to solar radiation and the ambient temperature as expected. Visual observations indicated that many important details of flashings and connections were deficient in design, fabrication, or both. These should be corrected for the system to function properly.

*Keywords: roofs, aluminum*

UNCLASSIFIED

SECURITY CLASSIFICATION OF THIS PAGE(When Data Entered)

## FOREWORD

This investigation was performed for the Defense Logistics Agency (DLA) by the Engineering and Materials Division (EM) of the U.S. Army Construction Engineering Research Laboratory (USA-CERL). The work was performed under Military Interdepartmental Purchase Request No. 81-938-16, dated 17 August 1981. Mr. Marvin U. DuBois was the DLA project monitor.

Appreciation is expressed to Mr. William Gordon of USA-CERL-EM for his efforts in installing the instrumentation and performing the measurements, and to Mr. Herbert Neff of the Ohio River Division, Corps of Engineers, and Mr. William Smith of the Facilities Engineer Office of the Defense Construction Supply Center, Columbus, OH, for their assistance.

Dr. R. Quattrone is Chief of USA-CERL-EM, COL Paul J. Theuer is Commander and Director of USA-CERL, and Dr. L. R. Shaffer is Technical Director.

Accession For	
NTIS CRA&I	<input checked="" type="checkbox"/>
DTIC TAB	<input type="checkbox"/>
Unannounced	<input type="checkbox"/>
Justification	
By _____	
Distribution /	
Availability Codes	
Dist	Avail and/or Special
A7	



## CONTENTS

	Page
DD FORM 1473	1
FOREWORD	3
LIST OF TABLES AND FIGURES	5
<b>1 INTRODUCTION</b> .....	<b>7</b>
Background	
Objective	
Approach of Overall Study	
Description of the Roofing System	
Mode of Technology Transfer	
<b>2 TEST PROGRAM INSTRUMENTATION</b> .....	<b>9</b>
Thermocouple Installation	
Gage Point Installation	
Instrumentation Measurements	
<b>3 DISCUSSION OF MEASUREMENTS</b> .....	<b>12</b>
Temperature Measurements	
Expansion Measurements	
Lateral Deflection Measurements	
<b>4 DISCUSSION OF VISUAL OBSERVATIONS</b> .....	<b>19</b>
Ridge Caps	
Counterflashing at Firewalls	
Ridge Vents	
Plumbing Stack Flashings	
Lightning Rod Installation	
Locking Panels to Anchor Clips	
<b>5 CONCLUSIONS AND RECOMMENDATIONS</b> .....	<b>22</b>
Conclusions	
Recommendations	
<b>APPENDIX: NBS Report</b>	<b>37</b>
<b>DISTRIBUTION</b>	

## TABLES

Number		Page
1	Hourly Temperatures, 16 July 1982	13
2	Hourly Temperatures, 4 January 1983	13
3	Hourly Temperatures, 12 July 1983	14
4	Hourly Temperatures, 4 January 1984	14
5	Hourly Temperatures, 17 July 1984	15
6	Expansion and Contraction Measurements	18
7	Deviation of Standing Seam from a Straight Line, 16 July 1982	20
8	Deviation of Standing Seam from a Straight Line, 4 January 1983	20
9	Deviation of Standing Seam from a Straight Line, 12 July 1983	21
10	Deviation of Standing Seam from a Straight Line, 4 January 1984	21
11	Deviation of Standing Seam from a Straight Line, 17 July 1984	22

## FIGURES

1	Warehouses at DCSC	7
2	NBS Test Rack of Samples for Corrosion Tests	8
3	Typical Thermocouple on Aluminum Panel	9
4	Cross Section of Warehouse 5 Showing Thermocouple Locations	10
5	Arrangement of Elongation and Deflection Measurement Points	11
6	Typical Elongation and Deflection Measurement Point	11
7	Temperature Data, 16 July 1982	15
8	Temperature Data, 4 January 1983	16
9	Temperature Data, 12 July 1983	16
10	Temperature Data, 4 January 1984	17
11	Temperature Data, 17 July 1984	17
12	Deviation of Standing Seam from a Straight Line, 16 July 1982	23

## FIGURES (Cont'd)

Number		Page
13	Deviation of Standing Seam from a Straight Line, 4 January 1983	24
14	Deviation of Standing Seam from a Straight Line, 12 July 1983	24
15	Deviation of Standing Seam from a Straight Line, 4 January 1984	25
16	Deviation of Standing Seam from a Straight Line, 17 July 1984	25
17	Damage to Ridge Cap (July 1983)	26
18	Damage at Ridge Cap Expansion Joint (July 1984)	26
19	Manufacturer's Design of Ridge Cap Expansion Joint	27
20	Buckled Flange of Ridge Cap (July 1984)	27
21	Firewall Counterflashing (July 1982)	28
22	Interlocked Ends of Counterflashing (July 1982)	28
23	Separation of Counterflashing from Wall (July 1984)	29
24	Connection of Ridge Cap to Ventilator Flashing (January 1984)	29
25	Buckled Flange of Ventilator Flashing (July 1983)	30
26	Broken Flange Joint of Ventilator Flashing (January 1984)	30
27	Poor Alignment of Plumbing Stacks (July 1984)	31
28	Panel Seam Cut Twice for Plumbing Stacks (July 1984)	31
29	Close-up of Plumbing Stack Flashing (July 1984)	32
30	Lightning Rod Installation (January 1984)	32
31	Open Hole Around Lightning Rod (July 1983)	33
32	Lightning Rod on Ventilator (January 1984)	33
33	Multiple Button Punches Along a Row of Clips (July 1984)	34
34	Recommended Attachment of Ridge Cap to Panel Closure	34
35	Recommended Firewall Counterflashing Detail	35

# FIELD TEST RESULTS OF ALUMINUM STANDING-SEAM ROOFING

## 1 INTRODUCTION

### Background

Most Army facilities use conventional roofing systems, such as built-up roofing (BUR), that are sometimes expensive and complicated to construct. Such systems are often comparatively short-lived, resulting in high life-cycle roofing costs. The Office of the Chief of Engineers has tasked USA-CERL with identifying alternative, easy-to-install roofing systems that can improve the performance of Army roofing and reduce its life-cycle costs.

The Defense Logistics Agency (DLA) was preparing to replace 6-year-old BUR with aluminum standing-seam roofing on warehouses 4, 5, and 8 at the Defense

Construction Supply Center (DCSC) at Columbus, OH (Figure 1). Being aware of the roofing investigation program, DLA asked USA-CERL and the National Bureau of Standards (NBS) to review the drawings and specifications, observe the construction, and monitor the behavior of the system for 2 years following completion. A report describing and evaluating the construction was published in 1983.<sup>1</sup>

### Objective

The overall objective of this project is to determine the behavior of aluminum standing-seam roofing over two annual cycles and to evaluate its capacity for long-term, trouble-free performance. This report describes the instrumentation and discusses the results of the measurements and visual observations.

<sup>1</sup> Rosenfield, Myer J., *Construction of Aluminum Standing-Seam Roofing at an Army Facility*. Interim Report M-336/ADA136401 (USA-CERL, November 1983).

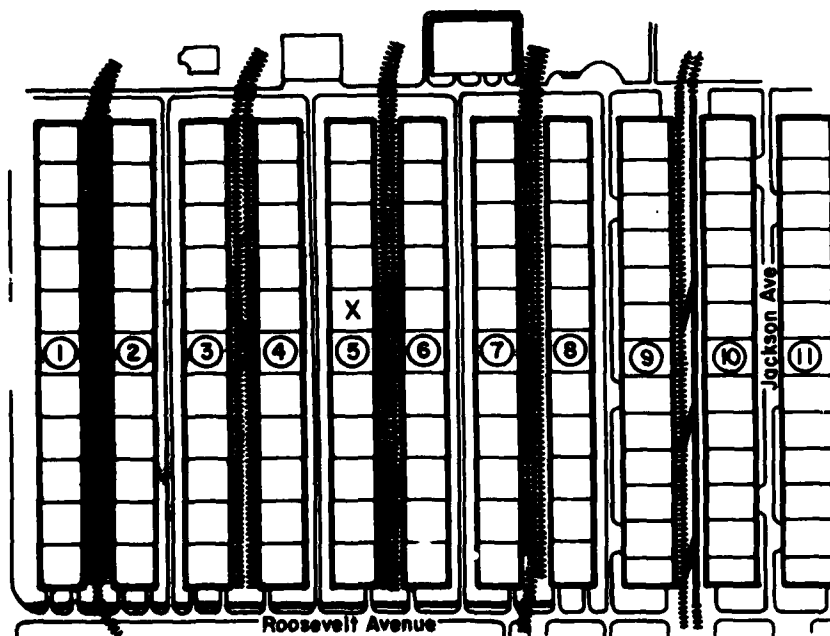

X = INSTRUMENTED SECTION  
BUILDING 5 SECTION 5

Figure 1. Warehouses at DCSC.

### Approach of Overall Study

The following tasks were established to accomplish the work:

1. Observe and monitor the construction of the roofing.
2. Perform the following specific measurements and observations on the roofing every 6 months for 2 years:
  - a. Observe condition and performance of the roofing system at periodic intervals and conduct required testing. This work would include checking each component, such as panel, flashing, and ridgecap, for corrosion, deformation, and movement.
  - b. Measure deformation and movement of the roof panels.
  - c. Measure temperatures of the metal roofing, the existing BUR and the building interior with thermocouples.
  - d. Analyze and evaluate the results of these observations and measurements.

NBS has analyzed panel samples to determine the extent and type of corrosion, using appropriate metallographic techniques such as microphotography and scanning electron microscopy. The samples are mounted on a special rack on Warehouse 5 (Figure 2). The appendix provides their report.

### Description of the Roofing System

Warehouse 5 at DCSC was selected for instrumentation. This warehouse is 160 ft\* wide by 1541 ft long, and divided by firewalls into 11 approximately equal sections, each about 140 ft long. Roofs are constructed with a slope of approximately 5/8 in. per foot (5 percent). Roofing panels are 1 ft wide. With panels continuous from the central ridge to the eaves, each panel is 80 ft long. Thus, there are about 3036 individual panels on each warehouse.

Panels are held in place by clips fastened to the roof. Each clip has bulbs at the top which fit into the seam and prevent the roof panels from lifting off while permitting expansion and contraction. Clips along the center of the panels act as anchors, permitting the panels to expand or contract freely at the ends.

### Mode of Technology Transfer

Information derived from this investigation will be used as the basis for revisions to Corps of Engineers Guide Specifications CEGS-07413, *Metal Roofing and Siding, Plain* and CEGS-07415, *Metal Roofing and Siding, Factory-Color-Finished*.

\*Metric conversion factors are provided on p 23.

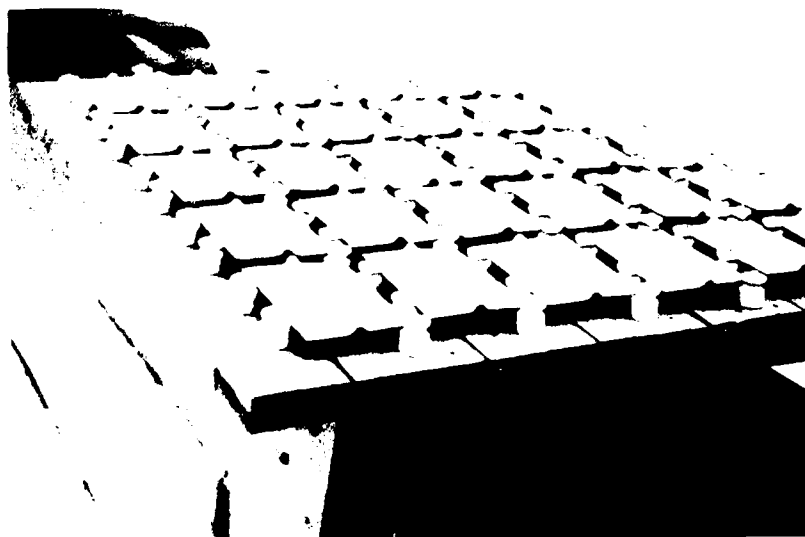

Figure 2. NBS test rack of samples for corrosion tests.

## 2 TEST PROGRAM INSTRUMENTATION

### Thermocouple Installation

Six vertical stacks of thermocouples were installed on Warehouse 5, Bay 5, approximately 37 ft from the north firewall parapet. Each stack consists of three thermocouples: one on top of the aluminum roof panel, one on top of the existing BUR, and one on the lower surface of the roof deck, inside the warehouse. On the aluminum panel, the thermocouples were epoxied to the surface and covered with aluminized silicone sealant (Figure 3). On the existing BUR, they were set in and covered with melted asphalt. The interior thermocouples were nailed to the underside of the roof deck. Two additional thermocouples were also installed for reference purposes: one nailed to the building exterior on the west side below the gutter, approximately 5 ft from the north end of the bay, and one just below a switchbox on an interior column 40 ft from the north wall and 60 ft from the east wall. All 20 thermocouple cables were run to a multiposition switchbox and digital readout where temperature data could be easily taken. Thermocouple locations are shown in Figure 4. Thermocouples 1, 4, 7, 10, 13, and 16 are on the aluminum panel; thermocouples 2, 5, 8, 11, 14, and 17 are on the BUR; and thermocouples 3, 6, 9, 12, 15, and 18 are on the underside of the deck. Thermocouple 19 is below the switchbox and 20 is on the exterior wall.

### Gage Point Installation

Fifteen reference points (S1-S15) were measured off and marked with a center punch at 5-ft intervals on the top of a standing seam on both the east and west sides of the roof approximately 36 ft from the north end of the bay, starting 5 ft from the eave. These gage points were used for expansion-contraction measurements along the length of the roof panels and for lateral deflection measurements of the standing seam. Gage point locations are shown in Figure 5 and a typical gage point in Figure 6.

### Instrumentation Measurements

Measurements were taken and recorded at the time of the initial installation in July 1982 and at 6-month intervals for the next 2 years: January 1983, July 1983, January 1984, and July 1984. Readings from all 20 thermocouples were recorded at 1-hour intervals from before sunrise to after sunset, for 1 day of each inspection visit. Local weather conditions were also noted at the time of each reading.

Expansion-contraction measurements were taken with a 100-ft steel tape. Two sets of measurements were taken on the same day as the hourly temperature measurements: one in the morning and one in the afternoon. Readings were taken to the nearest 1/8-in.

Lateral deflection measurements were taken by measuring the offset of the gage points from a taut string stretched between the end points. A 6-in. steel

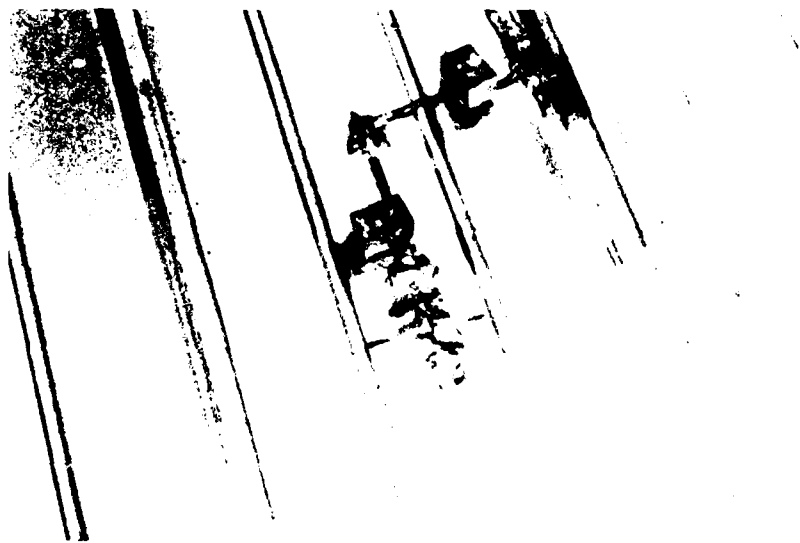

Figure 3. Typical thermocouple on aluminum panel.

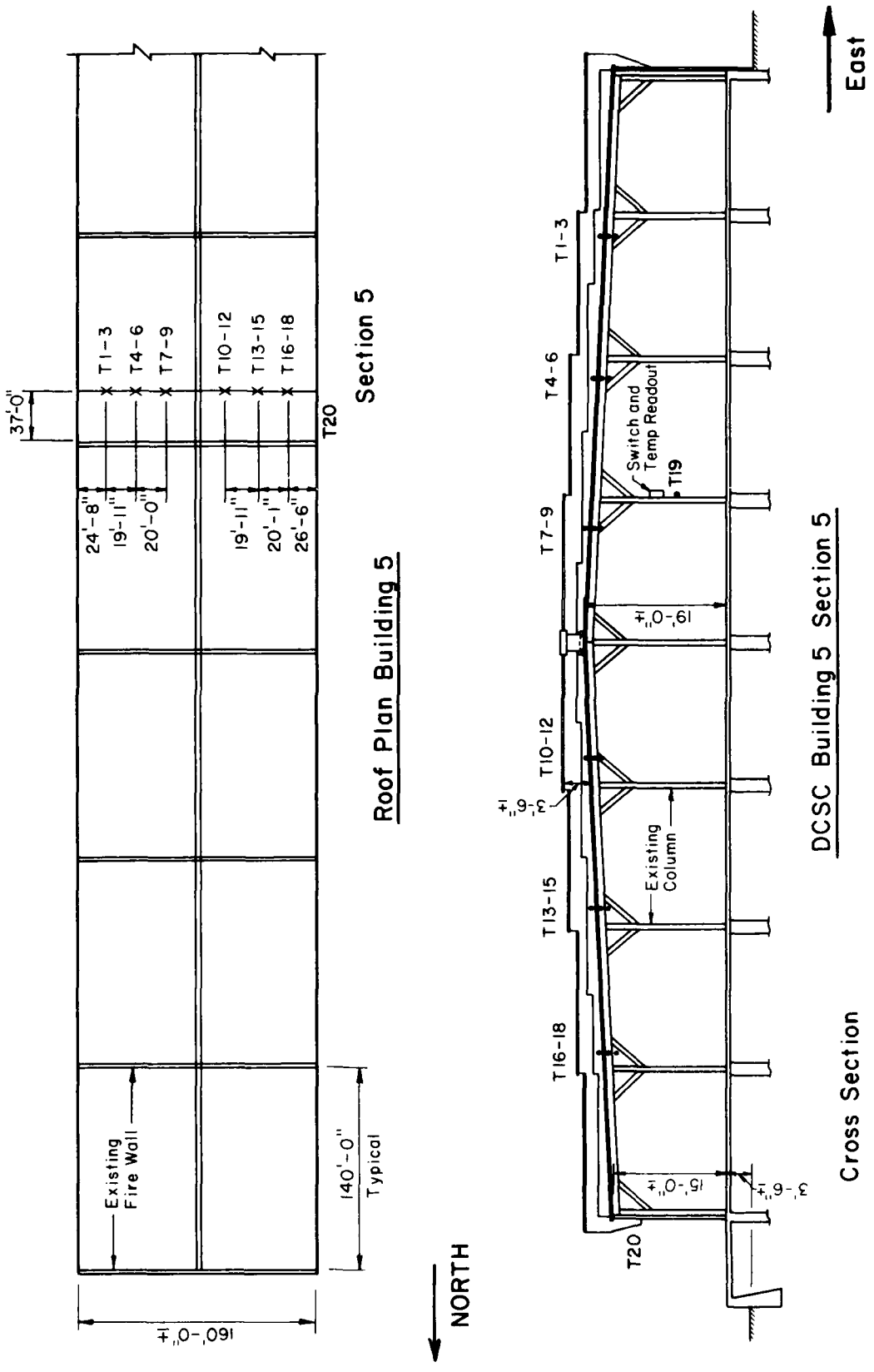

Figure 4. Cross section of Warehouse 5 showing thermocouple locations.

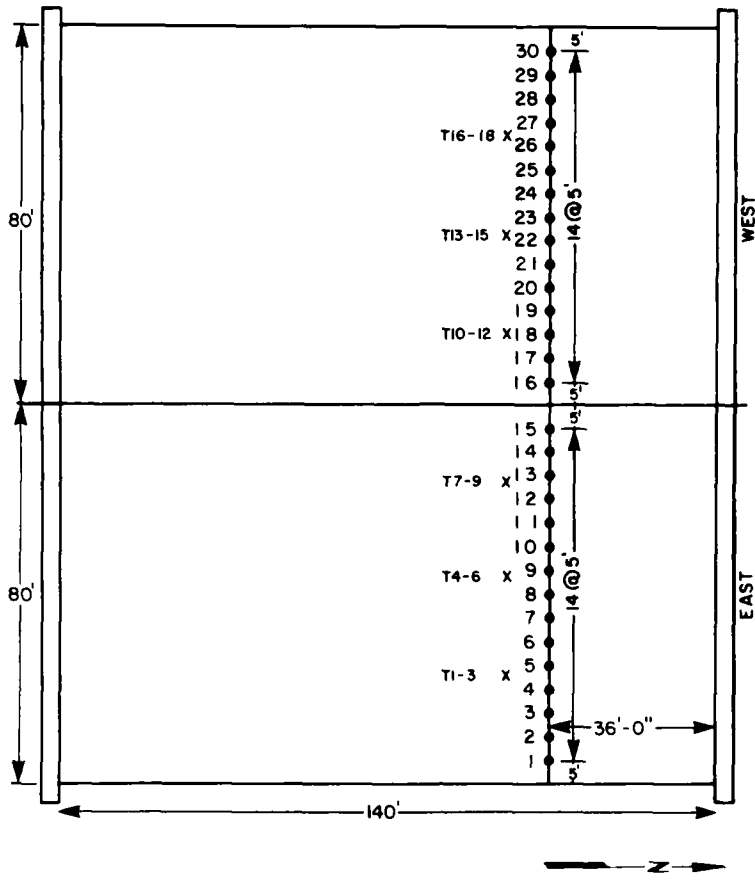

Figure 5. Arrangement of elongation and deflection measurement points.



Figure 6. Typical elongation and deflection measurement point.

scale was used for this purpose. Wind gusts induced vibrations in the 70-ft long string, causing inaccuracies in the readings, which were taken to the nearest 1/64 in. Before readings were taken, a sign convention was established whereby all positions of the seam to the north of the string were considered positive (+) and all to the south were considered negative (-). Since the entire seam was bent to the south, the sign convention is not used in presenting the data in the report.

### 3 DISCUSSION OF MEASUREMENTS

#### Temperature Measurements

Recorded temperatures (Tables 1 through 5) indicate that although external temperatures varied by as much as 80°F during the summer, indoor temperatures, whether on the underside of the roof deck or on the column below the switch box, never varied by more than 5°F during the summer and 3°F during the winter. To illustrate the differences between these extremes, data from one thermocouple stack were plotted for each inspection visit (Figures 7 through 11).

The data show that although the surface temperature of the aluminum panels (T1 curves) dropped below the ambient temperature (T20 curves) during the night, it rose higher on winter days, and much higher on summer days. The wide range in hourly readings indicates that the aluminum roofing is not capable of storing heat, but absorbs and radiates it readily. The BUR beneath it, on the other hand, can retain its heat longer. The BUR temperatures (T2 curves) were higher than the aluminum temperatures during the night, lower on winter days and much lower during the heat of summer days. In all cases, there was a 4- or 5-hour lag between maximum aluminum temperature and maximum BUR temperature. Also, the aluminum temperature was more responsive to the solar radiation than to the ambient temperature (T20 curves), peaking in most instances at about 1330 hours Eastern Daylight Time (EDT), when the sun is closest to its maximum height. The lag in reaching maximum aluminum temperature on 17 July 1984 is probably due to the clouds which were continually passing overhead; it was completely overcast by 1600 hours.

The warehouse was not cooled during the summer nor heated during the two winter heating seasons when

the testing was conducted. The interior temperature was maintained by solar radiation alone, at a level to prevent freezing or frosting of the contents. The temperature at the underside of the roof deck (T3 curves) differed only slightly from the interior temperature measured at the column by thermocouple T19. (T19 values can be read in Tables 1 through 5.)

The slight changes in indoor temperatures, especially during the summer, indicate that even though the aluminum roof itself can reach a high temperature, this heat is not transmitted into the building, but is reflected back into the atmosphere.

#### Expansion Measurements

As previously stated, expansion-contraction measurements were taken with a steel tape and read to the nearest 1/8 in. These measurements were converted to decimals of a foot (Table 6) as an aid in performing calculations. To determine true changes in length from summer to winter conditions when using a steel tape to measure lengths of aluminum, the differences in coefficients of thermal expansion must be considered. Aluminum will change twice as much as steel, lengths and temperature changes being equal. The tape manufacturer stated that the tape was fabricated from AISI 1095 steel, and was calibrated at 68°F. For higher temperatures, it is necessary to add the calculated expansion of the steel to the measured expansion of the aluminum to obtain the true expansion of the aluminum. For lower temperatures, it is necessary to add the calculated contraction of the steel to the measured contraction of the aluminum to obtain the true contraction of the aluminum. Theoretically, the sum of the expansion and contraction should equal the total change in length between summer and winter.

This reasoning can be used to check the measurements recorded at the site.

Let  $L_{31}$  = Tape reading at 0915 on 4 Jan 83 between gage points S1 and S15 = 69.9883

$L_{145}$  = Tape reading at 1415 on 12 July 83 between gage points S1 and S15 = 70.0000

The equation for the aluminum panel is

$$\Delta L_A = L_N \cdot C_A \cdot \Delta T \quad [Eq 1]$$

where  $\Delta L_A$  = Calculated change in length of aluminum panel

$L_N$  = Nominal distance between gage points S1 and S15 = 70 ft

**Table 1**  
**Hourly Temperatures, 16 July 1982**

Thermocouple	Time																	
	6	7	8	9	10	11	12	13	14	15	16	17	18	19	20	21	22	
T1	67	72	83	96	105	110	116	117	117	117	116	109	98		87	80	80	
T2	72	73	74	76	79	82	84	87	89	89	91	91	90		87	85	85	
T3	75	75	75	75	75	75	76	76	76	77	77	78	78		78	77	79	
T4	67	72	83	97	105	113	118	121	120	118	118	110	98		87	80	80	
T5	73	73	74	76	79	82	85	88	89	90	92	92	92		89	85	86	
T6	74	75	75	75	75	75	75	76	76	77	77	77	77		78	76	79	
T7	67	72	84	98	107	114	119	122	121	119	119	110	98		87	79	80	
T8	72	73	74	76	79	82	87	89	91	92	93	94	93		90	86	87	
T9	75	75	75	75	74	75	75	76	76	76	77	78	78		78	77	79	
T10	66	69	79	87	99	112	116	120	119	117	121	112	99		87	80	80	
T11	64	65	69	78	89	94	96	95	95	94	94	93	92		89	85	86	
T12	74	75	74	74	75	75	76	77	77	77	77	78	78		78	77	79	
T13	65	69	78	88	101	111	114	119	119	117	121	111	98		88	81	80	
T14	62	63	69	80	99	95	95	96	96	96	96	96	94		91	87	86	
T15	74	75	74	74	74	75	76	76	76	77	77	78	78		79	77	79	
T16	65	69	78	87	98	112	114	120	119	116	121	112	99		87	81	80	
T17	62	64	70	84	101	94	94	94	93	94	93	93	92		89	86	85	
T18	74	74	74	74	75	76	76	77	77	77	77	78	78		79	78	79	
T19	75	76	75	75	75	75	75	75	76	76	76	76	77		77	78	79	
T20	74	73	73	77	80	84	87	92	93	98	101	97	94		90	86	83	

**Table 2**  
**Hourly Temperatures, 4 January 1983**

Thermocouple	Time																	
	6	7	8	9	10	11	12	13	14	15	16	17	18					
T1	20	20	21	29	37	48	54	55	58	52	45	39	35					
T2	28	27	27	28	33	35	37	40	42	44	45	44	43					
T3	47	47	47	46	48	47	47	47	47	48	48	48	48					
T4	21	21	21	28	38	49	53	56	57	52	44	38	34					
T5	27	27	27	29	34	36	38	40	43	45	46	44	43					
T6	48	47	47	47	48	47	47	47	47	48	49	48	48					
T7	20	20	21	28	39	49	53	56	56	52	44	38	34					
T8	27	26	26	29	33	35	37	39	42	44	45	44	43					
T9	48	47	47	48	47	47	47	47	48	48	49	48	49					
T10	21	21	21	28	36	47	52	56	59	55	47	39	35					
T11	28	27	27	28	32	34	37	39	42	44	45	45	44					
T12	48	47	47	47	48	47	47	47	48	48	49	48	49					
T13	21	21	21	28	37	47	52	55	58	55	47	39	35					
T14	28	27	27	28	32	34	37	40	42	44	46	45	43					
T15	48	47	47	47	48	47	47	47	47	48	49	48	49					
T16	23	23	23	29	37	47	52	55	57	55	47	39	35					
T17	29	28	28	30	34	36	39	41	44	46	47	45	44					
T18	48	47	47	47	48	47	47	47	47	48	49	48	49					
T19	49	49	49	48	50	49	48	49	49	49	51	49	49					
T20	18	20	21	23	24	31	34	43	47	46	43	36	25					

**Table 3**  
**Hourly Temperatures, 12 July 1983**

Thermocouple	Time															
	6	7	8	9	10	11	12	13	14	15	16	17	18	19	20	21
T1	67	72	86	107	125	133	135	144	147	144	139	136	124	110	97	89
T2	73	72	74	77	82	87	91	97	102	104	105	106	106	104	102	97
T3	75	74	74	74	74	75	75	76	77	77	78	78	79	79	79	79
T4	67	72	87	108	126	133	136	142	145	143	139	134	123	108	97	88
T5	73	72	74	78	83	89	93	98	102	105	105	106	105	103	101	96
T6	74	74	74	74	74	74	75	76	77	77	77	78	78	78	79	79
T7	67	72	87	107	125	131	134	137	141	140	136	131	122	107	96	88
T8	73	72	74	77	82	87	92	97	100	103	104	104	104	102	100	96
T9	74	74	74	74	74	74	75	75	76	77	77	77	78	78	78	78
T10	67	71	85	102	120	128	134	136	141	141	137	135	126	111	98	88
T11	73	72	73	76	81	86	91	96	100	103	104	105	105	103	101	97
T12	74	74	74	74	74	74	75	75	76	76	77	77	78	78	78	78
T13	68	72	85	102	120	127	134	131	136	136	134	134	125	110	98	89
T14	73	73	74	77	83	88	92	98	102	105	106	107	107	105	102	98
T15	74	74	74	74	74	74	75	75	76	77	77	78	78	79	79	79
T16	68	72	86	103	122	138	134	128	135	132	134	133	124	109	97	88
T17	73	73	74	77	82	87	92	96	100	102	103	103	103	101	99	95
T18	75	74	74	74	74	74	75	75	76	77	78	78	79	79	80	80
T19	75	75	75	75	75	75	75	75	76	76	76	76	77	77	77	77
T20	73	72	75	77	82	86	90	91	93	93	96	98	96	94	93	90

**Table 4**  
**Hourly Temperatures, 4 January 1984**

Thermocouple	Time													
	6	7	8	9	10	11	12	13	14	15	16	17	18	
T1		37	36	39	44	45	46	48	43	43	42	38	37	
T2		39	37	38	38	40	40	41	42	41	43	41	40	
T3		43	41	42	41	43	41	41	42	41	43	42	42	
T4		37	35	39	44	45	45	48	43	43	42	38	37	
T5		39	37	38	38	40	40	41	42	41	42	41	40	
T6		43	41	42	41	43	41	41	42	42	43	42	42	
T7		37	35	39	42	45	45	48	43	43	42	38	37	
T8		39	37	38	38	40	40	41	41	41	42	41	40	
T9		43	41	42	41	43	41	41	42	42	43	42	42	
T10		37	35	39	43	45	45	48	43	43	42	38	37	
T11		39	37	38	38	40	40	40	41	41	42	41	40	
T12		43	41	42	41	43	41	42	42	42	43	42	42	
T13		37	36	39	43	45	45	48	43	43	42	38	37	
T14		39	37	38	38	40	40	41	41	41	42	41	40	
T15		43	41	42	42	43	41	41	42	42	43	43	42	
T16		37	36	40	44	45	45	48	43	42	42	38	37	
T17		40	37	39	39	41	41	41	42	41	43	41	40	
T18		43	41	42	42	43	41	42	42	42	43	42	42	
T19		45	42	43	42	43	42	42	43	43	44	43	43	
T20		37	35	37	38	39	38	39	39	38	39	37	37	

**Table 5**  
**Hourly Temperatures, 17 July 1984**

Thermocouple	Time																			
	6	7	8	9	10	11	12	13	14	15	16	17	18	19	20	21				
T1	57	64	82	107	118	126	132	133	143	144	128	114	104	91	85	75				
T2	65	65	67	70	76	82	86	91	95	99	100	100	99	95	90	85				
T3	73	73	73	73	73	75	74	75	76	76	77	77	77	77	77	77				
T4	57	64	84	108	119	128	133	133	141	142	127	112	103	91	85	75				
T5	65	65	68	72	78	83	88	91	96	100	100	100	99	95	90	84				
T6	73	74	74	74	74	75	74	75	75	76	76	76	76	77	77	76				
T7	56	64	83	107	119	127	132	132	138	139	126	112	102	90	84	75				
T8	65	65	70	71	77	82	86	90	94	98	98	98	97	94	89	84				
T9	73	74	74	74	75	76	75	76	76	77	76	76	76	76	76	76				
T10	57	60	77	99	113	124	129	129	137	138	124	113	102	90	84	75				
T11	66	65	66	69	75	80	85	88	93	97	98	99	98	94	90	85				
T12	73	75	75	76	76	77	77	77	77	78	77	76	77	77	77	77				
T13	57	61	77	100	112	123	127	128	135	134	123	111	101	90	85	75				
T14	65	65	67	61	66	82	86	90	95	99	101	101	100	96	90	85				
T15	73	76	76	76	77	77	77	78	78	79	77	77	77	77	77	76				
T16	57	61	78	102	112	124	127	128	134	133	122	109	98	88	84	75				
T17	65	65	67	71	77	82	86	89	93	97	97	97	95	91	87	83				
T18	74	76	76	76	76	77	77	77	78	78	77	77	77	77	77	77				
T19	74	74	74	74	74	75	75	75	75	75	76	75	76	75	76	76				
T20	61	63	67	70	74	78	79	82	84	87	88	87	84	82	78	79				

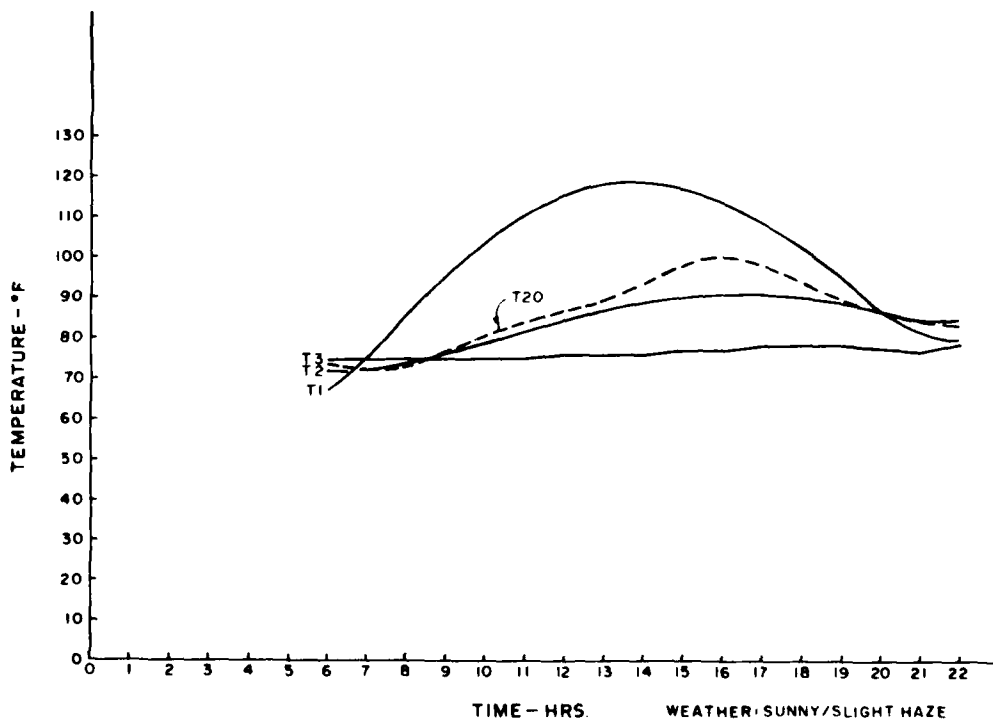

Figure 7. Temperature data, 16 July 1982.

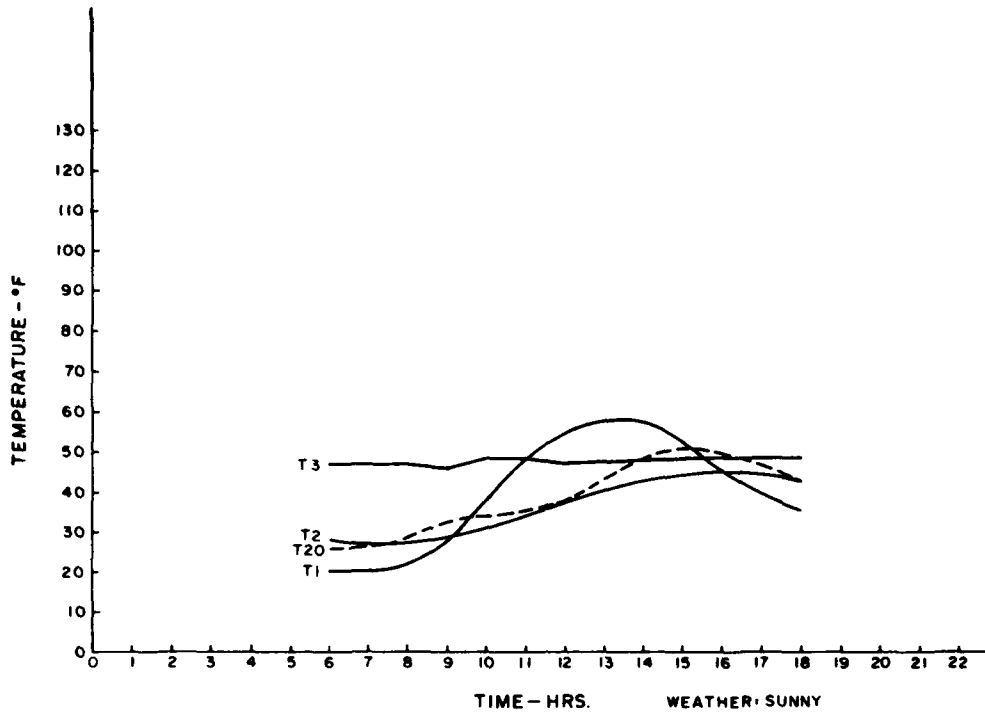

Figure 8. Temperature data, 4 January 1983.

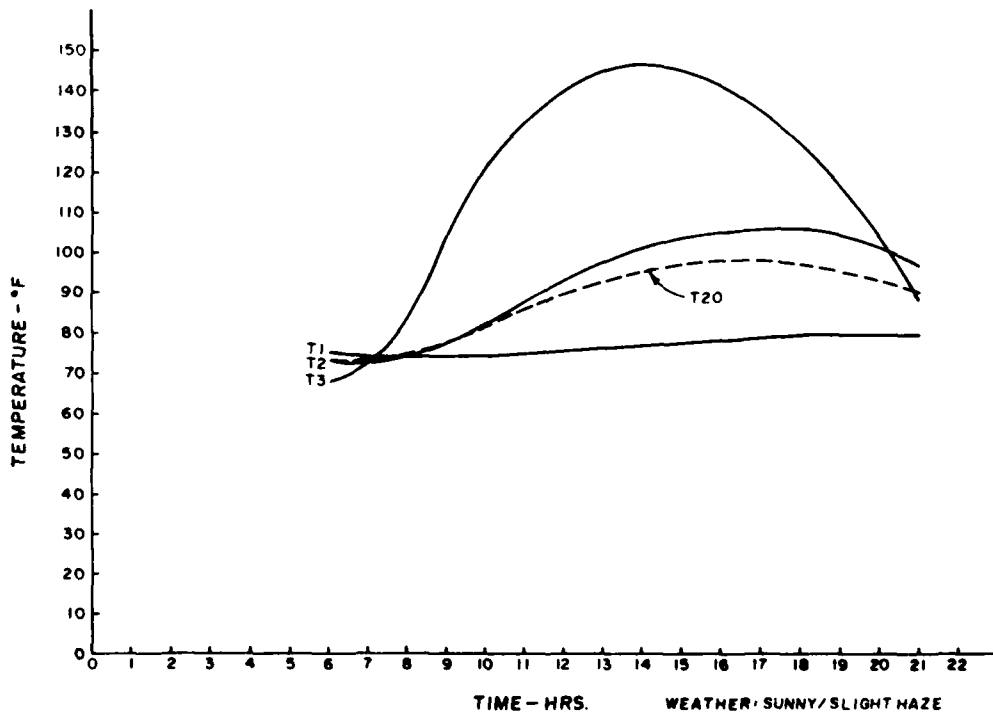

Figure 9. Temperature data, 12 July 1983.

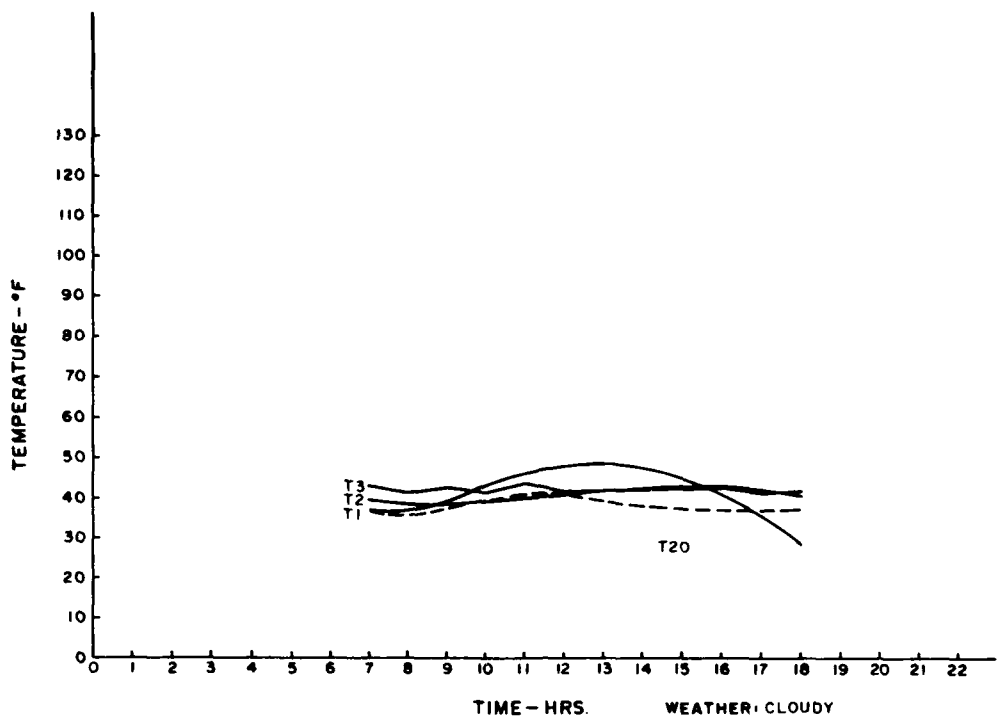

Figure 10. Temperature data, 4 January 1984.

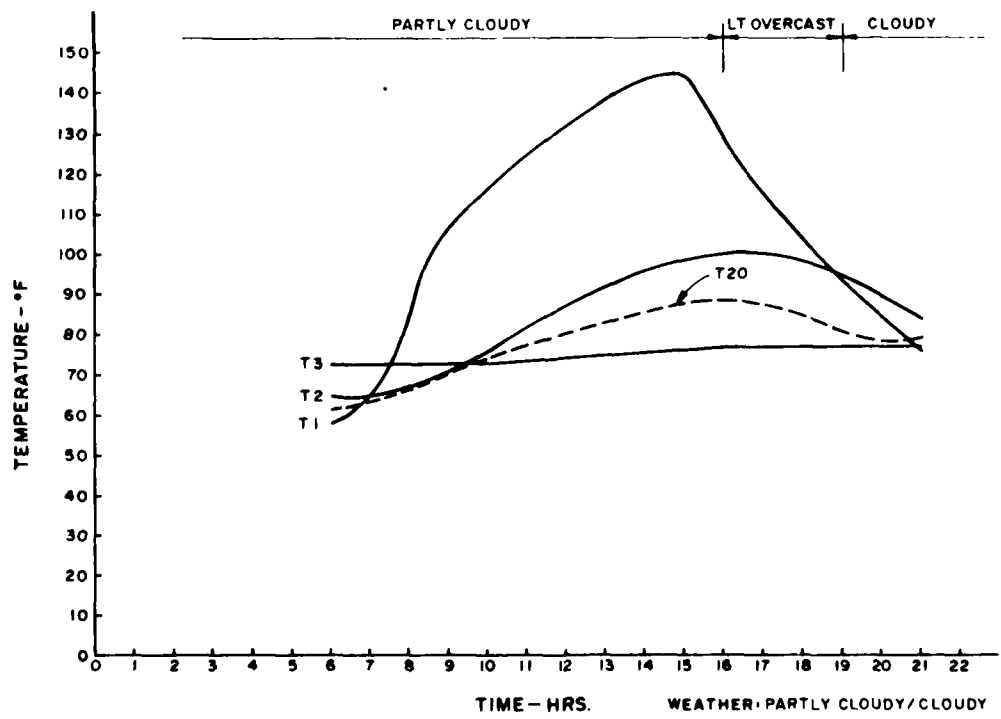

Figure 11. Temperature data, 17 July 1984.

**Table 6**  
**Expansion and Contraction Measurements**

Date	Time	Surface Temp. °F	Weather	East Side		West Side				
				S1-S8	S8-S15	S1-S15	S16-S23	S23-S30	S16-S30	
16 July 82	0815	84	Haze	34.9792	34.9792	69.9688				
	1130	113	Sunny	34.9792	34.9896	69.9896	35.0000	35.0000	69.9896	
	1430	118	Sunny	34.9792	34.9896	69.9792	34.9896	35.0000	70.0000	
4 Jan 83	0915	31	Sunny	34.9792	34.9792	69.9583	34.9896	34.9896	69.9792	
	1500	52	Sunny	34.9792	34.9792	69.9583	34.9792	34.9792	69.9792	
12 July 83	0930	116	Haze	34.9896	34.9167	69.9583	35.0156	35.0417	70.0417	
	1415	145	Sunny	35.0000	34.9792	70.0000	35.0521	35.0313	70.0417	
4 Jan 84	0930	41	Pt. Cldy	34.9792	34.9792	69.9583	34.9792	34.9792	69.9583	
	1415	43	Cloudy	34.9792	34.9792	69.9583	34.9896	34.9896	69.9792	
17 July 84	0920	112	Pt. Cldy	34.9792	34.9896	69.9792	34.9896	35.0104	69.9792	
	1400	143	Pt. Cldy	34.9896	35.0000	70.0000	35.0000	35.0000	70.0104	

$C_A$  = Coefficient of thermal expansion of aluminum = 0.0000129

$\Delta T = 145 - 31 = 114F^\circ$ , assuming tape and panel are at the same temperature.

The equation for the steel tape is:

$$\Delta L_S = L_N \times C_S \times \Delta T \quad [\text{Eq 2}]$$

where  $\Delta L_S$  = calculated change in length of steel tape

$$L_N = 70 \text{ ft}$$

$C_S$  = coefficient of thermal expansion of steel = 0.0000065

$$\Delta T = 114$$

Using values from Table 6 and the above, the calculations are as follows:

$$\begin{aligned} \Delta L_A &= L_N \times C_A \times \Delta T \\ &= 70 \times 0.0000129 \times 114 \\ &= 0.1029 \text{ ft} \end{aligned}$$

$$\begin{aligned} \Delta L_S &= L_S \times C_S \times \Delta T \\ &= 70 \times 0.0000065 \times 114 \end{aligned}$$

$$= 0.0519 \text{ ft.}$$

The theoretical measured change in length from winter to summer will then be  $0.1029 - 0.0519 = 0.0510$  ft.

The actual measured change in length was  $L_{145} - L_{31}$ , or  $70.0000 - 69.9583 = 0.0417$  ft.

The difference between the theoretical and actual changes is  $0.0510 - 0.0417 = 0.0093$  ft or 0.1116 in., which is less than 1/8 in., the experimental error of reading the tape.

Besides verifying the tape reading, this calculation also indicates that the roofing system expands and contracts freely, thus performing as expected.

It is now only necessary to determine the force required to stretch the tape 1/8 in.

The equation for calculating this force can be expressed as:

$$P = \frac{\delta AE}{L} \quad [\text{Eq 3}]$$

where  $P$  = the force

$\delta$  = the amount of stretch = 1/8 in.

$A$  = the cross section area of the tape

L = the nominal length = 70 ft (converted to inches)

E = the modulus of elasticity =  $30 \times 10^6$  psi.

The tape dimensions are 0.375 in. wide  $\times$  0.008 in. thick.

Substituting the proper values,

$$P = \frac{0.125 \times 0.375 \times 0.008 \times 30 \times 10^6}{70 \times 12}$$
$$= 13.3 \text{ lb.}$$

It is very doubtful that a force of this magnitude would be used in holding the tape to take the measurements.

#### Lateral Deflection Measurements

The lateral deflection of one of the east side standing seams was measured to check for buckling resulting from binding at any of the clips. The expansion calculations have shown that the aluminum roofing panels tend to expand and contract freely, so buckling should not occur. This is borne out by examining the data and studying the curves plotted from them. The curves, of course, are drawn as averages through the data points. From the similarity of their shapes, it can be deduced that the camber (horizontal curvature) was built into the seam during construction and was retained for the entire 2 years. As with the expansion measurements, this also indicates that the system expands and contracts without restraint. The data are in Tables 7 through 11 and the curves are in Figures 12 through 16.

## 4 DISCUSSION OF VISUAL OBSERVATIONS

Although the roofing appeared to be in very good condition and was performing well, close examination revealed several places where more care should have been exercised in design, fabrication, and installation. Those places are as follows.

#### Ridge Caps

Of all the components of the aluminum roofing system, the ridge cap is the least supported. Only the flanges are fastened to the roofing panels. The raised portion relies on its own stiffness. If this should be

inadvertently stepped on, which probably caused the damage shown in Figure 17, it may not be possible to straighten the cap without first removing it. It is unlikely that the damage was caused by expansion. An expansion joint is visible in Figure 17 and its design is such that it should act as a slip joint between sections.

Figure 18 shows a damaged expansion joint in the ridge cap. It also shows that the expansion joint was fabricated similar to the manufacturer's design, as detailed in Figure 19, but was not installed properly. A buckled flange was noted at one location on the ridge cap (Figure 20). This may have occurred during original installation rather than as a result of expansion. However, the exact cause is not known. The effect is not serious since there is already a space between the top of the panel closure and the ridge cap, which is not gasketed.

#### Counterflashing at Firewalls

The most serious damage to roofing components has been associated with the counterflashing. Aluminum has a high coefficient of thermal expansion to begin with, and if this is not taken into account when the system is designed and installed, the results can be disastrous. Such has happened to this system. The counterflashing was made in 10-ft long sections, stepped and tapered to follow the roof slope, as shown in Figure 21. These sections were installed so the end of the outer section was slit to interlock with the end of the inner section, as shown in Figure 22. This was done to make it more difficult for the wind to lift the section of counterflashing. The actual effect of this interlocking was to restrain the sections from expanding freely, causing the counterflashing to separate from the wall and the sealant to split (Figure 23).

#### Ridge Vents

It was previously reported<sup>2</sup> that the ridge cap and ridge ventilator flashing dimensions were not coordinated when they were fabricated, so a large amount of sealant was needed to waterproof the connections. The effect of this error has become apparent. Figure 24 shows a condition typical of all these connections. The sealant has completely split, opening the joint between the two metal components and allowing wind and water to enter.

Figure 25 shows the effect of expansion on the flange of one of the ventilator flashings. Note that both flanges are fastened to the panel closure.

<sup>2</sup> Rosentfield, Interim Report M-336.

**Table 7**  
**Deviation of Standing Seam from a Straight Line,**  
**16 July 1982**

Time	0815	1150	1410
Temperature	78	90	95
Weather	Haze	Sunny	Sunny
<b>East Side</b>			
S1	0	0	0
S2	13/64	17/64	10/32
S3	23/64	13/32	29/64
S4	13/32	15/32	15/32
S5	13/32	31/64	15/32
S6	13/32	1/2	15/32
S7	7/16	33/64	1/2
S8	27/64	17/32	17/32
S9	25/64	17/32	33/64
S10	7/16	35/64	9/32
S11	7/16	9/16	31/64
S12	3/8	17/32	15/32
S13	5/16	25/64	25/64
S14	1/4	11/32	13/32
S15	0	0	0
<b>West Side</b>			
S16		0	0
S17		3/8	3/8
S18		7/16	7/16
S19		7/16	13/32
S20		7/16	3/8
S21		15/32	15/32
S22		1/2	29/64
S23		5/8	23/32
S24		9/16	11/16
S25		25/32	7/8
S26		23/32	23/32
S27		61/64	59/64
S28		17/32	9/16
S29		7/16	1/2
S30		0	0

**Table 8**  
**Deviation of Standing Seam from a Straight Line,**  
**4 January 1983**

Time	0915	1500
Temperature	23	44
Weather	Sunny	Sunny
<b>East Side</b>		
S1	0	0
S2	1/4	7/32
S3	7/16	5/16
S4	1/2	3/8
S5	1/2	13/32
S6	1/2	7/16
S7	17/32	1/2
S8	1/2	15/32
S9	7/16	7/16
S10	15/32	15/32
S11	13/32	15/32
S12	5/16	11/32
S13	7/32	5/16
S14	3/32	7/32
S15	0	0
<b>West Side</b>		
S16	0	0
S17	5/16	3/16
S18	13/32	1/4
S19	13/32	5/16
S20	3/8	5/16
S21	1/2	13/32
S22	9/16	15/32
S23	19/32	1/2
S24	7/16	3/8
S25	11/16	19/32
S26	9/16	7/16
S27	21/32	19/32
S28	5/16	3/16
S29	1/4	1/8
S30	0	0

As the photograph shows, the flange of the flashing is fastened to the panel closures at the ends of the panels. Since the 80-ft panels are anchored at the center, the expansion from 40 ft pushes toward the ventilator. At the same time, the ventilator flashing tends to expand opposite to the movement of the panel. The buckled flange is the result of the two opposing movements.

Another effect of this expansion can be seen in Figure 26. In this case, only one flange was fastened to the panel closure, and the flange joint broke open instead of buckling.

#### Plumbing Stack Flashings

The plumbing stacks were flashed according to the manufacturer's details. Due to the original building construction, the stacks could not be centered on a single panel of the roofing system (Figures 27 and 28). Figure 27 shows that one stack could be centered within a panel, so that the panel seams could be left undisturbed, while the other stack was sufficiently off-center that the seam had to be cut to clear the counterflashing. Figure 28 shows that one seam had to be cut twice with one stack centered on the seam. (A close-up of this condition is shown in Figure 29.) Note the heavy application of sealant around the

**Table 9**  
**Deviation of Standing Seam from a Straight Line,**  
**12 July 1983**

Time	0930	1430	1530
Temperature	81	100	100
Weather	Haze	Sunny	Pt. Cldy
<b>East Side</b>			
S1	0	0	
S2	15/64	11/32	
S3	13/32	31/64	
S4	7/16	1/2	
S5	27/64	25/64	
S6	29/64	7/16	
S7	33/64	15/32	
S8	31/64	1/2	
S9	15/32	15/32	
S10	15/32	17/32	
S11	33/64	29/64	
S12	13/32	25/64	
S13	25/64	13/32	
S14	1/4	13/64	
S15	0	0	
<b>West Side</b>			
S16	0		0
S17	3/8		3/8
S18	25/64		25/64
S19	29/64		15/32
S20	15/32		29/64
S21	17/32		1/2
S22	33/64		33/64
S23	11/16		5/8
S24	33/64		17/32
S25	47/64		3/4
S26	21/32		5/8
S27	51/64		47/64
S28	29/64		7/16
S29	13/32		13/32
S30	0		0

**Table 10**  
**Deviation of Standing Seam from a Straight Line,**  
**4 January 1984**

Time	0930	1415
Temperature	32	38
Weather	Pt. Cldy	Cloudy
<b>East Side</b>		
S1	0	0
S2	1/4	1/4
S3	7/16	7/16
S4	15/32	15/32
S5	3/8	3/8
S6	7/16	7/16
S7	9/16	17/32
S8	7/16	7/16
S9	3/8	13/32
S10	13/32	11/32
S11	13/32	3/8
S12	1/4	7/32
S13	3/16	3/16
S14	1/16	1/16
S15	0	0
<b>West Side</b>		
S16	0	0
S17	3/16	7/32
S18	13/32	11/32
S19	5/16	13/32
S20	7/16	7/16
S21	11/32	1/2
S22	1/2	1/2
S23	19/32	21/32
S24	7/16	9/16
S25	11/16	19/32
S26	19/32	5/8
S27	23/32	23/32
S28	11/32	13/32
S29	5/16	5/16
S30	0	0

base. Not visible in the photograph are the rubber plugs that the manufacturer suggests be inserted into the open ends of the seams. Those plugs tend to dry and shrink as they age, thus losing their effectiveness as seals. The contractor did not initially install rubber plugs, but sealed many openings with nonhardening sealant. The plugs were installed some time after construction.

#### Lightning Rod Installation

The original lightning protection system was left on the buildings when the aluminum roofing was installed. No provision for this could be found in the specifications and no details were on the drawings.

The result was that holes were cut into the ridge caps to allow for the rods, and sealant was applied to close them (Figure 30). As the sealant aged and the ridge cap moved back and forth from expansion and contraction, the sealant lost its function and left the hole open (Figure 31). Lightning rods were also mounted to the ridge ventilators (Figure 32). All cables are stranded copper, as are the lightning rods themselves, and the fittings are copper or bronze. The cables lie beneath the aluminum roofing on the old BUR surface. The metal roofing system is not grounded.

#### Locking Panels to Anchor Clips

The manufacturer recommends anchoring the panels at the center of their run, so that expansion

**Table 11**  
**Deviation of Standing Seam from a Straight Line,**  
**17 July 1984**

Time	0930	1415
Temperature	74	95
Weather	Pt. Cldy	Pt. Cldy
<b>East Side</b>		
S1	0	0
S2	5/32	1/8
S3	11/32	5/16
S4	3/8	11/32
S5	3/8	3/8
S6	13/32	11/32
S7	7/16	7/16
S8	7/16	7/16
S9	13/32	7/16
S10	13/32	15/32
S11	7/16	1/2
S12	9/32	13/32
S13	9/32	9/32
S14	1/8	3/16
S15	0	0
<b>West Side</b>		
S16	0	0
S17	3/16	9/32
S18	5/16	3/8
S19	11/32	3/8
S20	11/32	7/16
S21	15/32	1/2
S22	1/2	17/32
S23	17/32	9/16
S24	13/32	15/32
S25	19/32	23/32
S26	17/32	5/8
S27	5/8	11/16
S28	5/16	3/8
S29	1/4	5/16
S30	0	0

and contraction can occur freely at the ridge and eave ends. A special type of clip is provided for this purpose, and the panel seam is locked to the clip by means of a button punch. If the workman did not provide a means of accurately locating the anchor clip, many buttons had to be punched into a seam before the panel was anchored. As can be seen in Figure 33, the condition existed in several seams along the row of anchor clips.

## 5 CONCLUSIONS AND RECOMMENDATIONS

### Conclusions

Aluminum standing-seam roofing is capable of long-term, trouble-free performance, provided the design, fabrication and/or installation deficiencies are corrected. Methods to correct the deficiencies are listed below.

The temperature measurements indicated the roofing system performed as desired. Although the aluminum readily absorbed radiant energy, the resulting heat was not transmitted into the building.

The expansion and contraction measurements indicated the system behaved as predicted, within the experimental error of reading the tape. There is no impediment to free movement of the panels.

The visual examination revealed that many important details were deficient in design, fabrication, or installation.

### Recommendations

#### Ridge Caps

The ridge caps will be the easiest components of the roofing system to remove, repair, and replace. At the firewall ends, the ridge caps should be anchored to the walls by aluminum or stainless steel clip angles. The counterflashing could then incorporate a flange to cover the cap. Fasteners holding the ridge cap flanges to the panel closures should be removed and the holes sealed with closures similar to tinker's dams. Clip angles should be attached to the panel closures, and the ridge cap fastened to these clips through slotted holes. This recommendation is illustrated in Figure 34. Ridge cap expansion joints should be checked to determine if they are free to slide, and comply with the manufacturer's recommendation (Figure 19).

#### Counterflashing at Firewalls

Counterflashing should be removed and redesigned before being replaced. To reduce expansion, the counterflashing should be made of two pieces of stainless steel. A hook strip should be inserted into the

reglet and sealed into place. The counterflashing should then be hung from this hook strip, fastened at the center to keep it in place, with the lower edge supported by the existing hooks (Figure 35). Ends of the counterflashings should not be interlocked as they now are.

**Ridge Vents**

A new cover should be fabricated to fit over the connections between the ridge cap and the ventilator flashings. This cover would divert any water from entering the split joints. The flanges of the ventilator flashings should be attached to the panel closures with clip angles, similar to those recommended for the ridge cap. This design will help prevent buckling.

**Plumbing Stack Flashings**

Redesign of the plumbing stack flashing is not necessary. All that is required is to inspect all the opening seals, remove them if they are dried and shrunken, and replace with a new rubbery mastic.

**Lightning Rods**

A flanged sleeve made from aluminum tubing should be fastened to the ridge cap around the lightning rod. An umbrella-type counterflashing of copper or a copper-bearing alloy should then be fastened to the rod to cover the sleeve. Alternatively, a prefabricated rubber boot could be installed. In addition, the whole roofing system should be grounded.

Metric Conversion Factors	
1 in.	= 25.4 mm
1 ft	= 0.305 m
1 sq ft	= 0.093 m <sup>2</sup>
°C	= 5/9 (°F-32)
1 psi	= 6.89 kPa

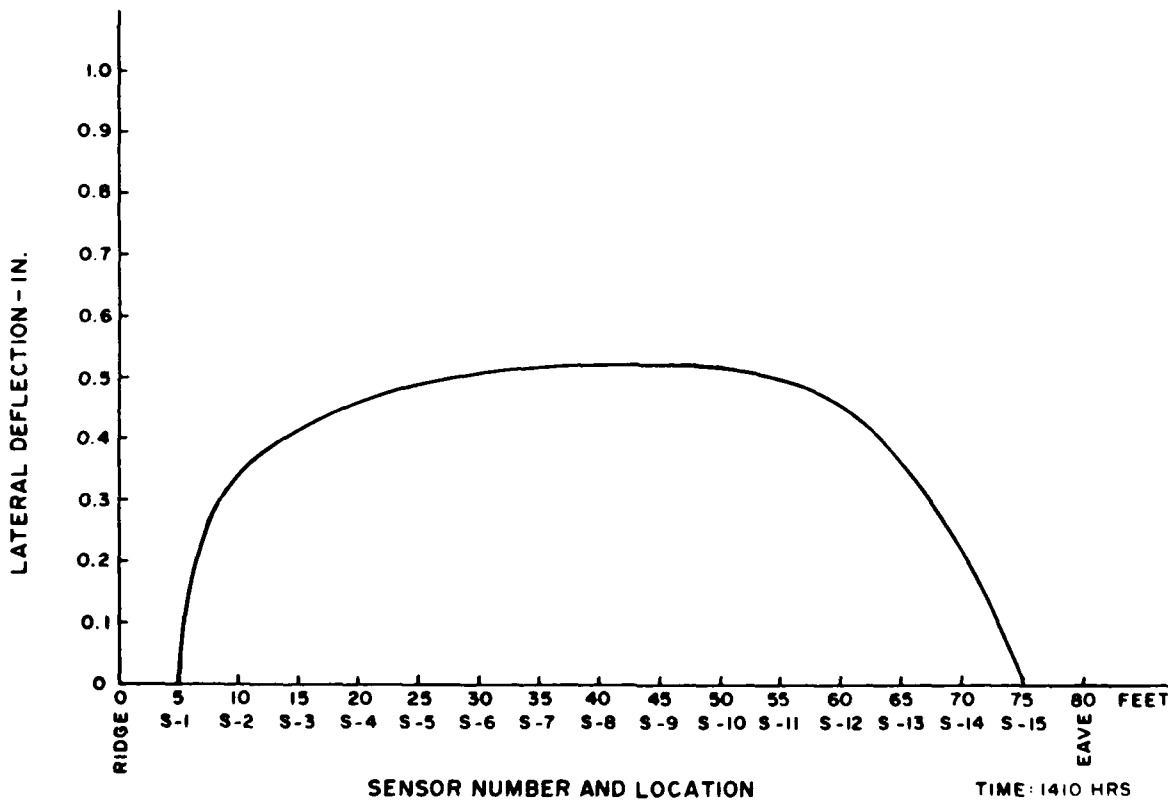

Figure 12. Deviation of standing seam from a straight line, 16 July 1982.

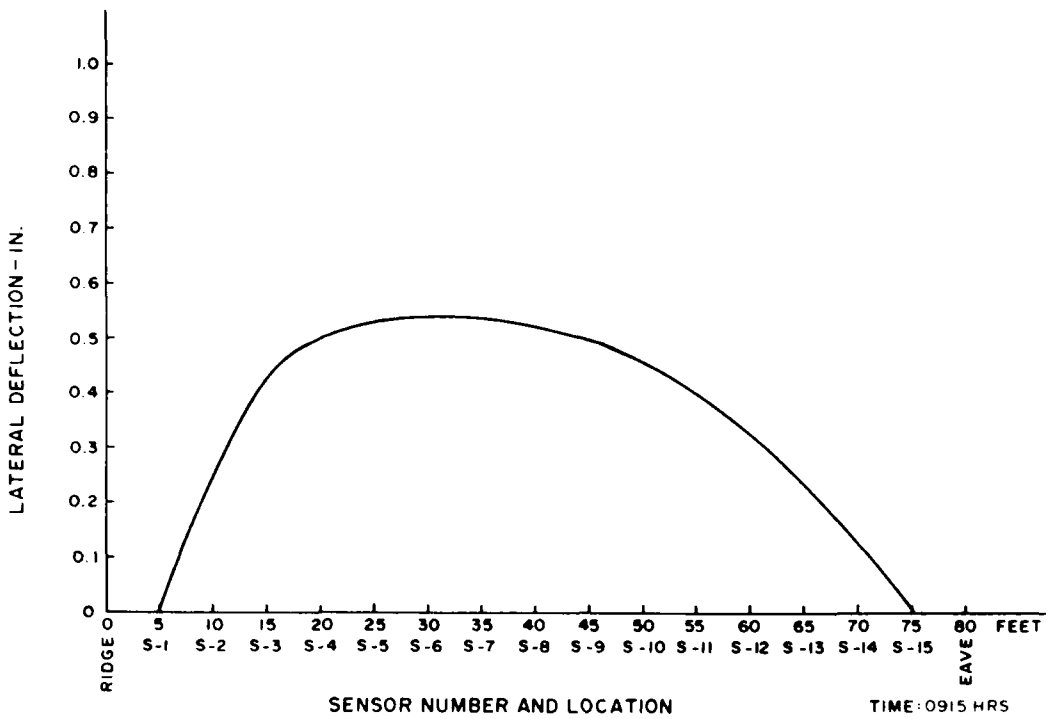

Figure 13. Deviation of standing seam from a straight line, 4 January 1983.

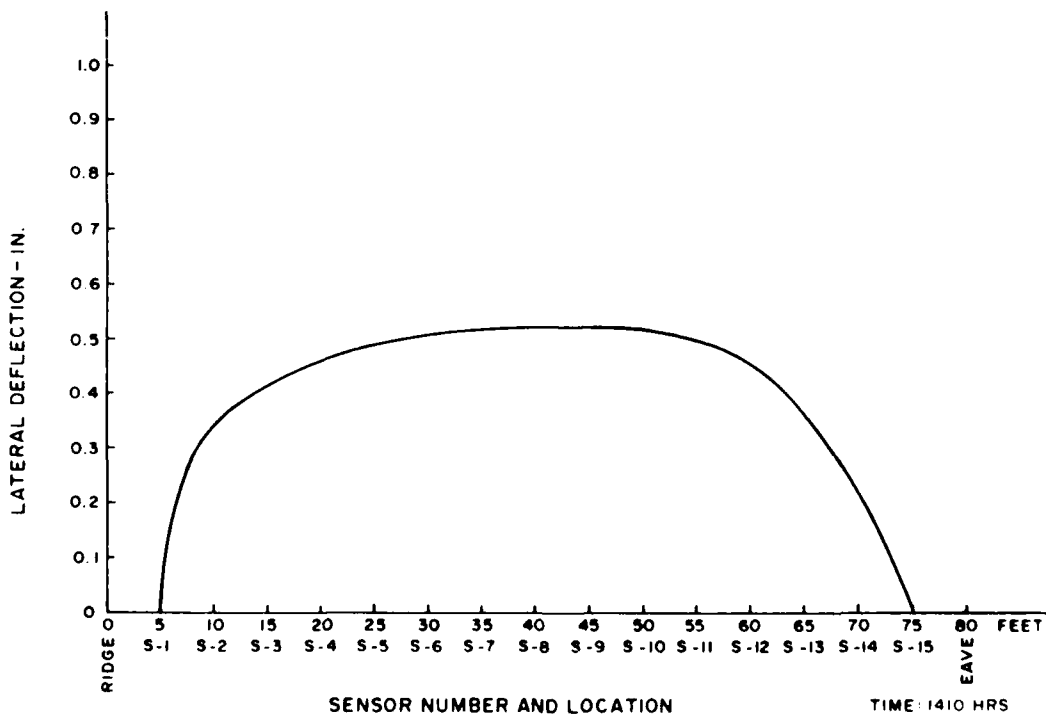

Figure 14. Deviation of standing seam from a straight line, 12 July 1983.

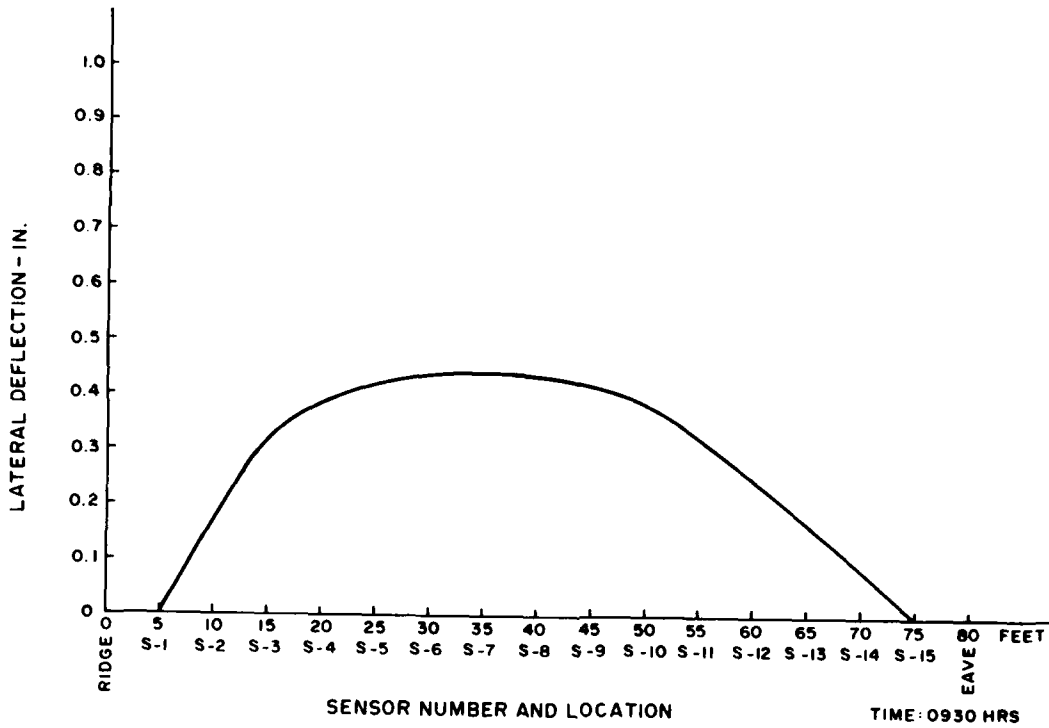

Figure 15. Deviation of standing seam from a straight line, 4 January 1984.

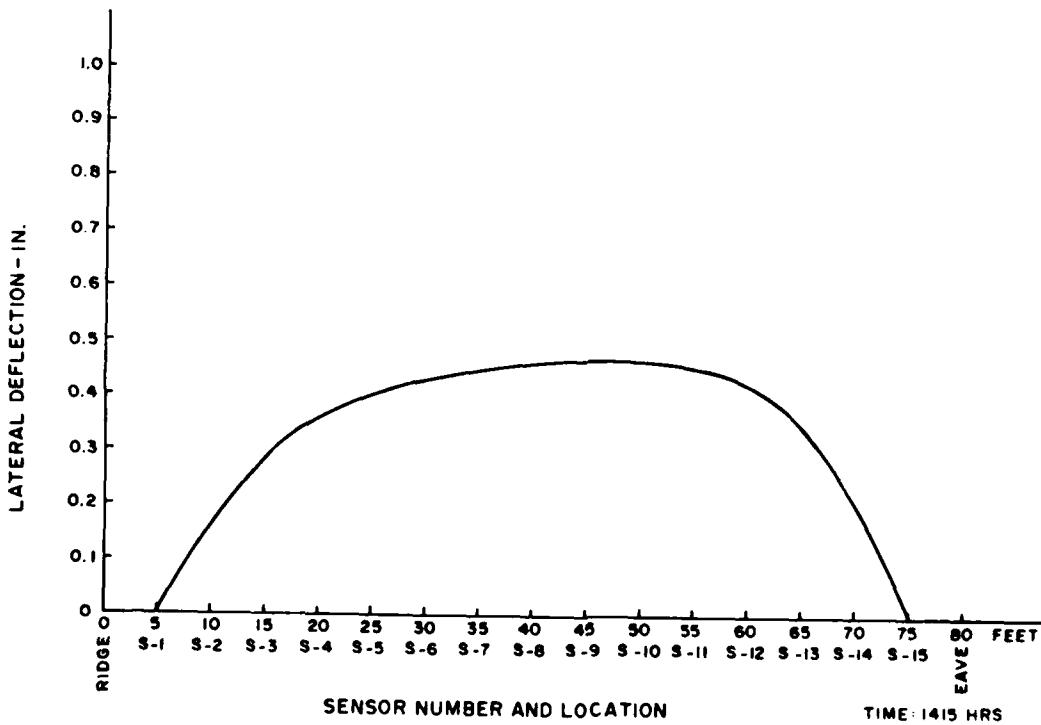

Figure 16. Deviation of standing seam from a straight line, 17 July 1984.

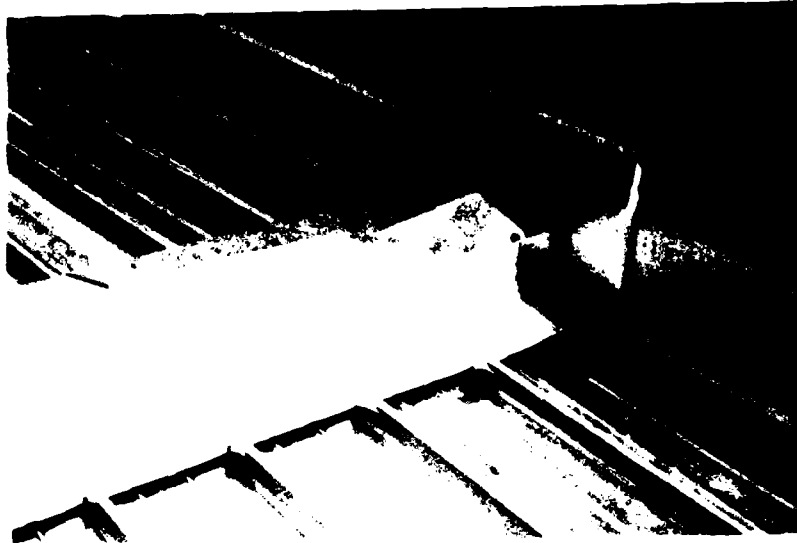

Figure 17. Damage to ridge cap (July 1983).



Figure 18. Damage at ridge cap expansion joint (July 1984).

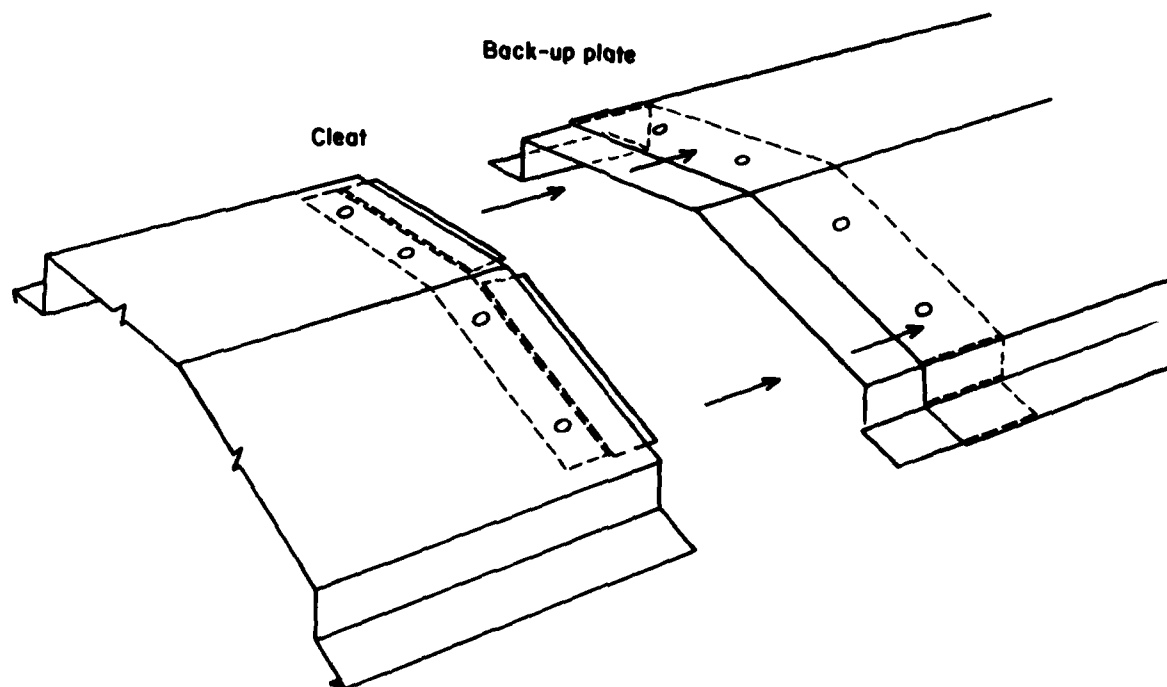

Figure 19. Manufacturer's design of ridge cap expansion joint.

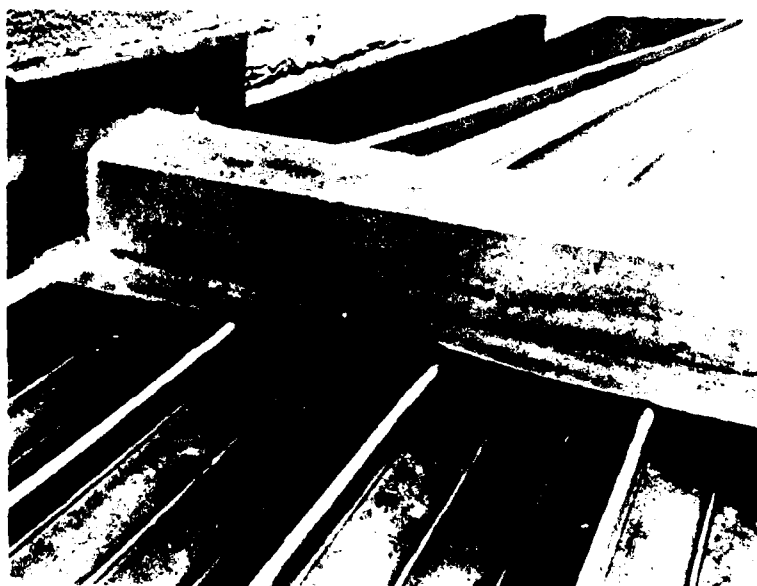

Figure 20. Buckled flange of ridge cap (July 1984).



Figure 21. Firewall counterflashing (July 1982).

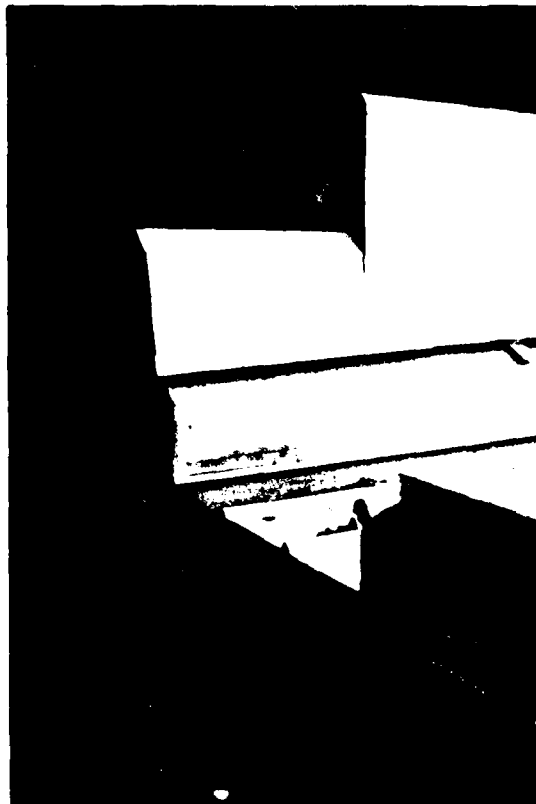

Figure 22. Interlocked ends of counterflashing (July 1982).



**Figure 23.** Separation of counterflashing from wall (July 1984).



**Figure 24.** Connection of ridge cap to ventilator flashing (January 1984).

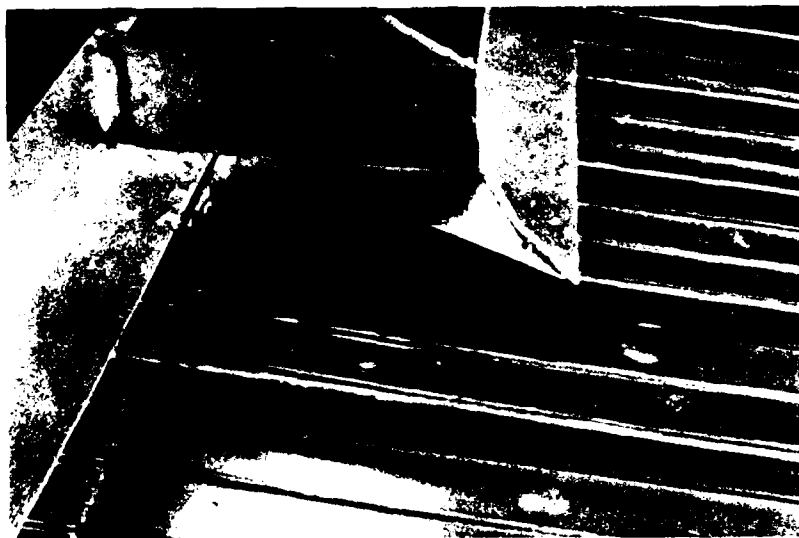

Figure 25. Buckled flange of ventilator flashing (July 1983).



Figure 26. Broken flange joint of ventilator flashing (January 1984).

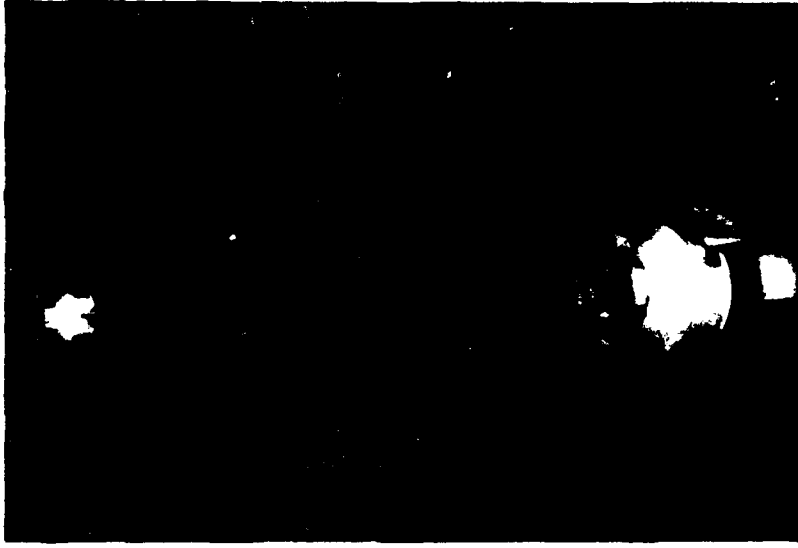

Figure 28. Panel seam cut twice for plumbing stacks (July 1984).

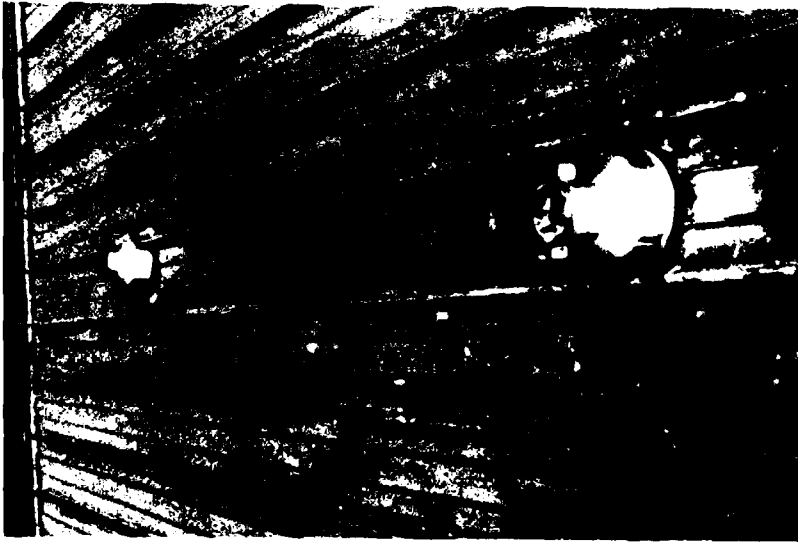

Figure 27. Poor alignment of plumbing stacks (July 1984).



Figure 29. Close-up of plumbing stack flashing (July 1984).

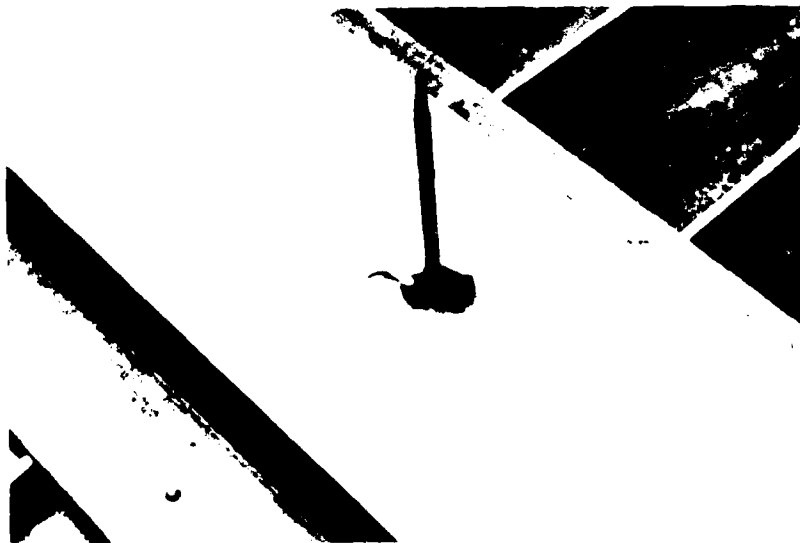

Figure 30. Lightning rod installation (January 1984).



Figure 31. Open hole around lightning rod (July 1983).

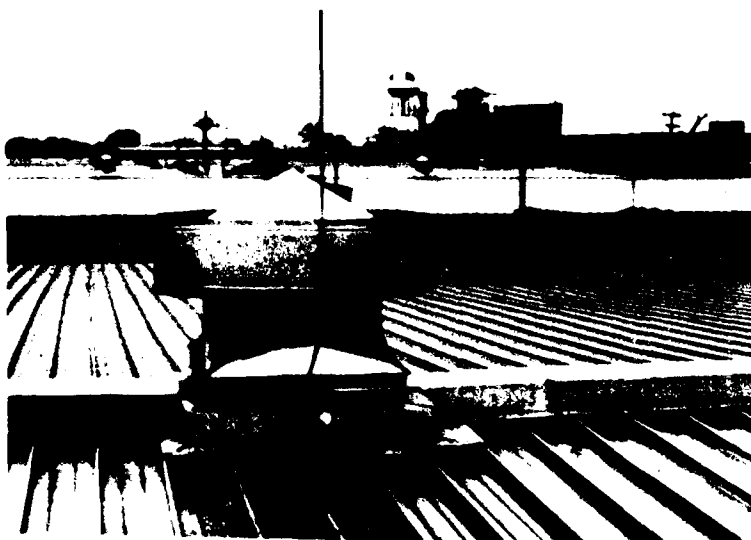

Figure 32. Lightning rod on ventilator (January 1984).

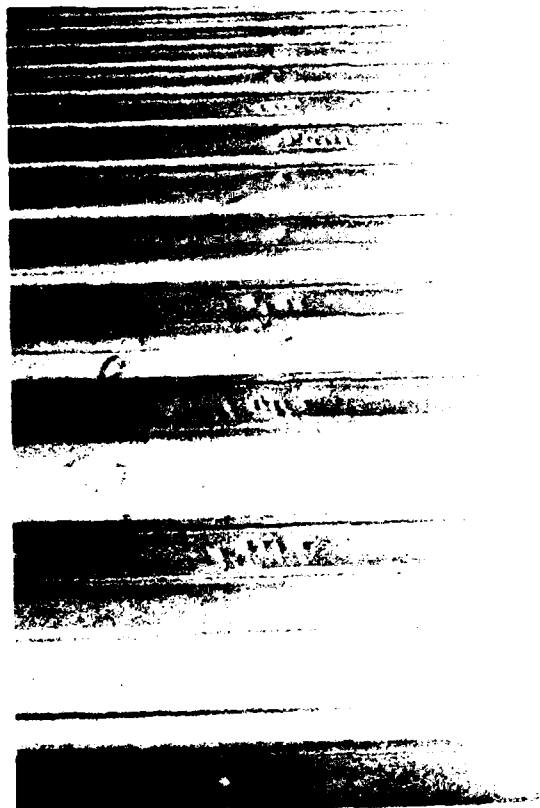

Figure 33. Multiple button punches along a row of clips (July 1984).

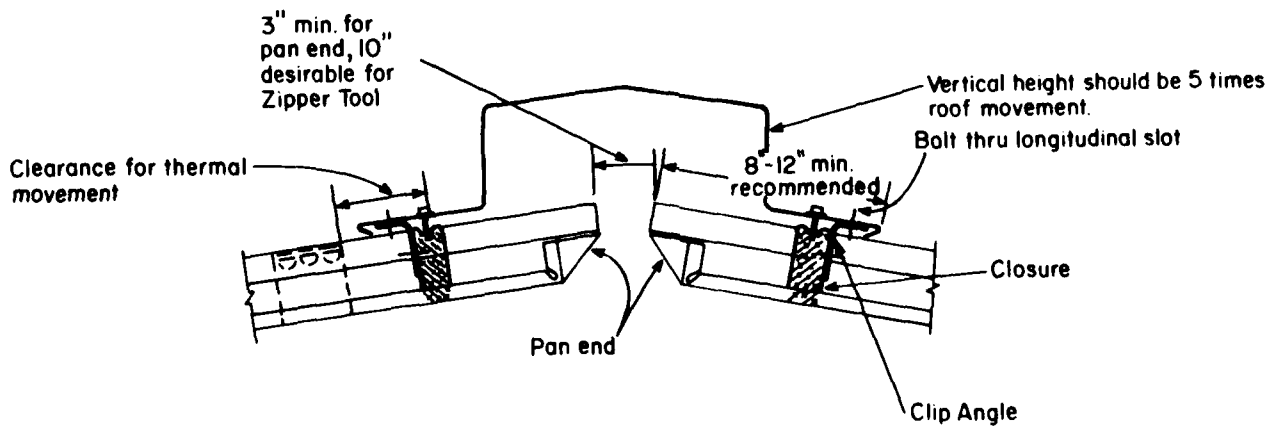

Figure 34. Recommended attachment of ridge cap to panel closure.

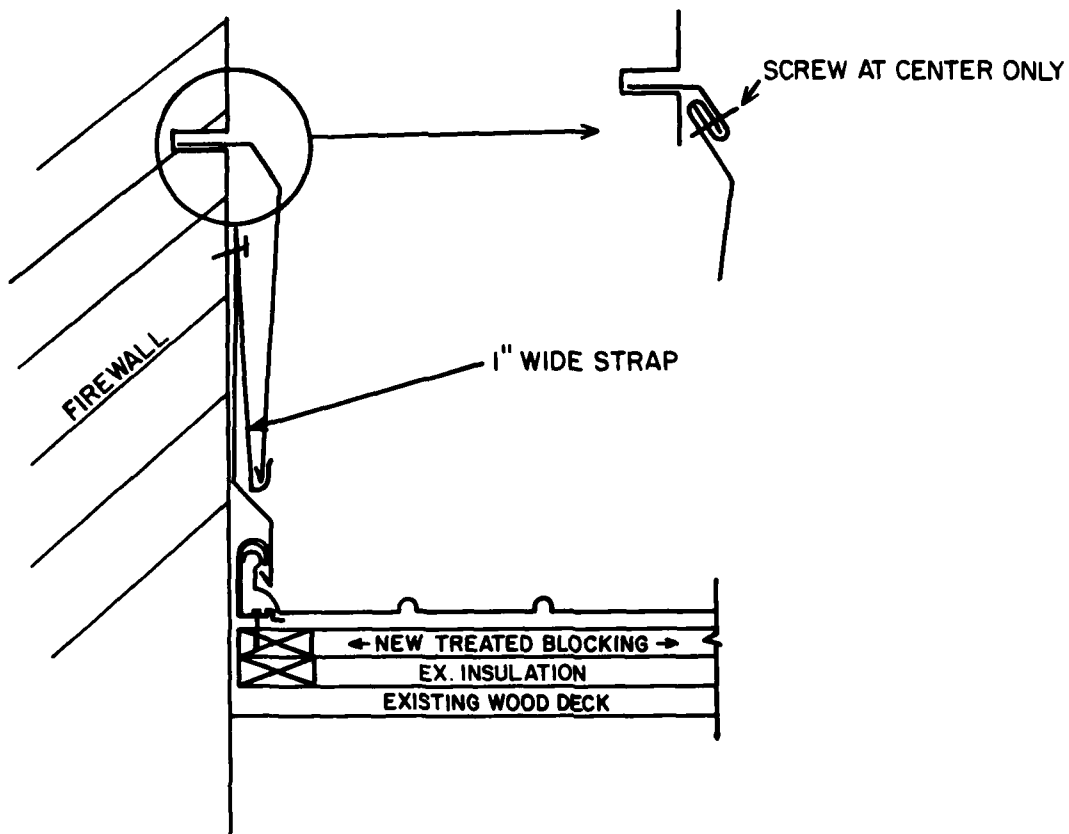

Figure 35. Recommended fire wall counterflashing detail.

APPENDIX:

NBSIR 86-3387

NBS REPORT

**INVESTIGATION OF THE CORROSION OF  
ALUMINUM STANDING-SEAM  
ROOFING AT AN ARMY FACILITY**

---

Robert G. Mathey

U.S. DEPARTMENT OF COMMERCE  
National Bureau of Standards  
National Engineering Laboratory  
Center for Building Technology  
Gaithersburg, MD 20899

June 1986

Prepared for:  
U.S. Army Corps of Engineers  
Construction Engineering Research Laboratory  
P.O. Box 4005  
Champaign, IL 61820

and

Defense Logistics Agency  
Installations Division  
Cameron Station  
Alexandria, VA 22314



---

**U.S. DEPARTMENT OF COMMERCE, Malcolm Baldrige, Secretary**  
**NATIONAL BUREAU OF STANDARDS, Ernest Ambler, Director**

#### ABSTRACT

An investigation was conducted to determine the extent of corrosion of an aluminum standing-seam roofing system exposed to weathering over a period of nearly three years. The aluminum roofing was installed on three large warehouses at an Army facility in Columbus, Ohio. A high performance elastomeric sealant was used in forming the standing seams of the roofing system. The roof slope, about 5 percent, was less than that usually recommended for unsoldered standing-seam roofing. The roofs were located in a region having a high level of acid rain.

In this preliminary study, small scale samples of the same material as the aluminum roofing were exposed on a rack mounted on the roof of one of the warehouses. The extent of corrosion of the roofing system was determined from measurements of mass and observations of the exposed small scale aluminum roofing samples. The change in mass of the exposed samples was compared to that of the control samples. The average rate of mass loss was calculated to be  $0.038 \text{ mg/dm}^2 \cdot \text{day}$ . Low power microscopic observations to determine the surface condition of the exposed samples after nearly three years exposure indicated a loss of gloss, an increase in surface roughness, and many small dark spots. At the dark spots, which were thought to be incipient corrosion, there was essentially no pitting.

## 1. INTRODUCTION

### 1.1 Background

In July 1981, the Defense Logistics Agency (DLA) requested that the National Bureau of Standards (NBS) and the U.S. Army Construction Engineering Research Laboratory (CERL) provide technical assistance for a project involving the installation of aluminum standing-seam roofing on three large warehouses at the Defense Construction Supply Center (DCSC) in Columbus, Ohio. Both NBS and CERL were given copies of the plans and specifications for review. At a preconstruction conference held at DCSC in October 1981, comments from both agencies and details regarding the aluminum roofing systems were discussed.

Aluminum standing-seam roofing was specified to replace built-up bituminous roofing on the three warehouses which were each about 160 ft (48.8 m) wide and 1541 ft (470 m) long. Firewalls divided the roof into approximately 11 equal sections, each about 138 ft (42 m) long. The centrally located ridge of the roof extended the length of the building. The roof slope from ridge to eaves was about 5/8 in. per foot (50 mm/m). The aluminum panels used in the roofing system were 1 ft (305 mm) wide, 0.032 in (0.81 mm) thick, and 80 ft (24 m) long. They were rolled-formed with a 2-1/2 in. (64 mm) high rib on each side and two low profile equally spaced intermediate ribs. A strip type sealant was used in forming the standing seam which joined two panels together. The purpose of the sealant was to make the seam watertight. Construction of the aluminum standing-seam roofing at DCSC is described in CERL interim report M-336 [1]\*.

One concern with the aluminum roofing system was the relatively low slope of the roof. The Department of Defense Manual on Maintenance and Repair of Roofs states that unsoldered standing-seam roofing should be used with slopes of 3 in. per foot (250 mm/m) or greater [2]. In addition, the standing-seam method for metal (unsoldered seams) roofing illustrated in the Architectural Sheet Metal Manual [3] is recommended for roofs having a slope of 3 in. per foot (250 mm/m) or greater. It is noted that the manufacturer of the aluminum roofing system recommended a minimum slope of 1/2 in. per foot (40 mm/m). Because of the relatively low slope of the aluminum roofs and also because Columbus, Ohio is located in an area having a high level of acid rain, DLA requested that NBS conduct a preliminary assessment of the performance of the aluminum roofing with regard to corrosion.

In carrying out the DLA aluminum roofing project, CERL had the overall responsibility to determine the behavior of the aluminum standing-seam roofing system over two annual cycles and to evaluate its capacity for long-term, trouble-free performance. The CERL report [1] documents the construction and instrumentation of the roof system for one of the three DCSC warehouses on which it was installed. Specific tasks assigned to CERL were to observe and monitor the construction of the roofing on the warehouses, to observe condition and performance of the roofing at periodic intervals, to measure deformation

---

\* Numbers in brackets indicate references listed in Section 5.

and movement of roof panels at appropriate locations, to measure temperatures of the metal and existing built-up roofing, and analyze and evaluate the results of the observations and measurements. The results of the analysis and evaluation will be documented by CERL in a final report.

## 1.2 OBJECTIVE AND SCOPE

The objective of this study was to conduct a preliminary assessment of the corrosion of the aluminum roofing system over a three year period using samples of the same roofing material that were exposed on a rack mounted on the roof of one of the warehouses. The change in mass of the exposed samples was measured and low power microscopic observations were conducted to determine the surface condition and extent of corrosion.

## 2. OUTDOOR EXPOSURE OF ALUMINUM ROOFING SAMPLES

### 2.1 DESCRIPTION AND PROPERTIES OF SAMPLES

Fourteen pieces, each about 16 in. (40 cm) long, of the 1 ft (30 cm) wide aluminum roofing panels were obtained and used to prepare samples for the exposure tests. These 16 in. (40 cm) long pieces were cut from the 80 ft (24 m) long panels at ventilator locations on the roof. Four samples for exposure tests were prepared from each of the 16 in. (40 cm) length of panel. The exposure samples were approximately 4 x 6 in. (10 x 15 cm) and had a low profile rib in the center that extended the length of the sample. Figures 1 and 2 show the sample configuration; figure 2 also shows a large area of the aluminum roofing system.

The aluminum panels has a nominal thickness of 0.032 in. (0.81 mm) and a textured finish described by the manufacturer as "stucco embossed." The average density of the aluminum roofing panels determined from tests of 42 specimens was 171.12 lb/ft<sup>3</sup> (2.74 g/cm<sup>3</sup>). The manufacturer reported the panels to be corrosion resistant Alclad 3004\* and they were furnished in mill finish.

### 2.2 EXPOSURE TESTS

Thirty samples were mounted on a rack and exposed at the same angle as the roofing. Figures A1 and A2 show the exposure rack mounted on the firewall of one of the warehouses at DCSC. The exposure rack faced west.

Each of the aluminum roofing samples was supported by six porcelain insulators. The method of support allowed for expansion and contraction of the samples without introducing stress in them. The samples were not in contact with any other material. Round slots in the insulators where the samples were supported (figure A2) allowed some movement of the samples and still maintained their adequate attachment. The insulators were held in place by screws attached to the wood rack. The distance between the samples and the wood rack was about 7/8 in. (22 mm).

The cleaning of the samples for their initial weighing and exposure consisted of soaking them in acetone for 10 to 30 minutes and rinsing them in ethyl alcohol. It is noted that this initial cleaning was found to be unsatisfactory. Because of this, the average rate of mass loss of the exposed samples was determined from a second exposure period. The samples for exposure were chemically cleaned before and after the second exposure period. Of the 56 samples included in the tests, 30 were selected for exposure and 26 were used

---

\* This description was used to identify the aluminum roofing material, it does not represent an endorsement or disapproval by the National Bureau of Standards.

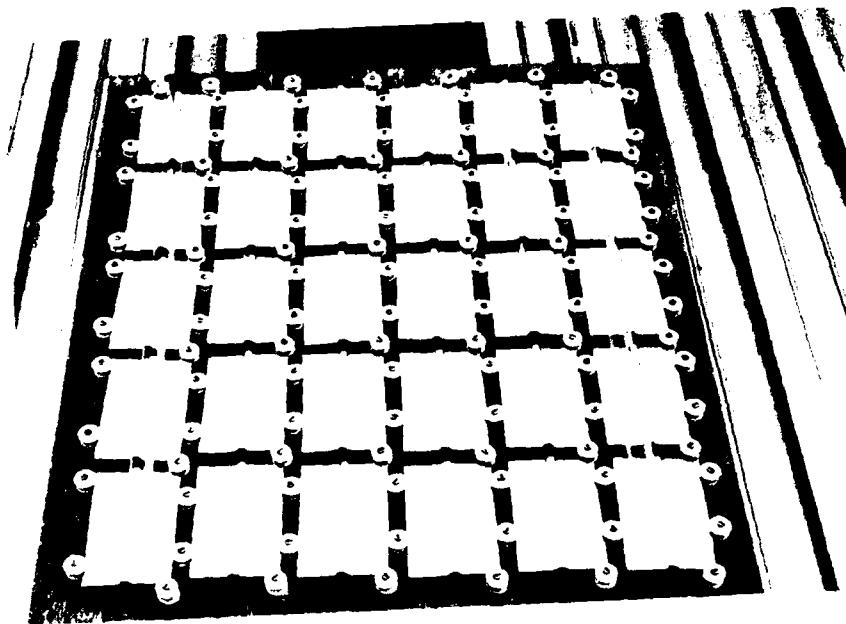

Figure A1. Aluminum roofing samples mounted on exposure test rack.

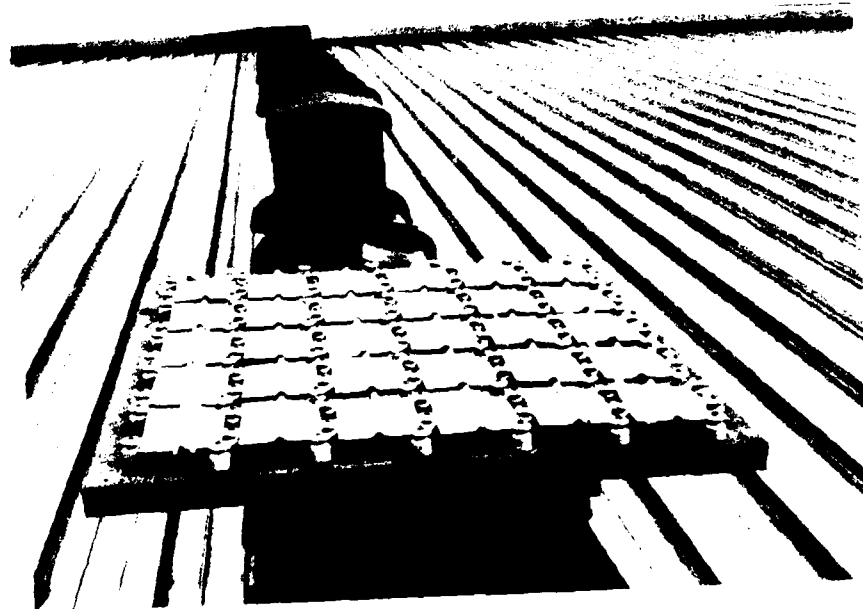

Figure A2. Exposure test rack attached to fire wall between sections of roofing.

as control samples. The control samples were stored in the laboratory in polyethylene bags and protected from light, moisture, and sources of contamination.

After 206 days of exposure (first exposure) the samples were returned to the laboratory, and both the exposed and control samples were weighed, chemically cleaned, following the methods in ASTM G1-81 [4], and weighed again. The exposure surfaces, or tops, of the samples were subjected to low power microscopic examination. The samples were then reinstalled on the exposure rack and exposed for 797 days (second exposure). After this second exposure they were returned to the laboratory and weighed, chemically cleaned, and weighed again. They were also examined visually and by using a light microscope at 10x.

### 3. LABORATORY MEASUREMENTS AND OBSERVATIONS

#### 3.1 MASS LOSS

The samples were initially installed for exposure at DCSC on August 10, 1982, and removed for laboratory tests and observations on March 3, 1983 (first exposure). The samples were reinstalled on the exposure rack at DCSC on May 23, 1983, and removed for the second time for laboratory tests on August 1, 1985 (second exposure).

The samples were weighed before and after cleaning prior to the initial exposure and for each of the two times that they were returned to the laboratory for testing. The initial cleaning consisted of soaking them in acetone for 10 to 20 minutes and rinsing them in ethyl alcohol. When the samples were returned to the laboratory after exposure at DCSC they were chemically cleaned essentially as described by ASTM G1-81 for aluminum alloys [4]. The chemical cleaning of both the exposed and control samples was conducted as follows:

#### step

1. Samples were dipped in the following mixture:

Chromic acid ( $\text{CrO}_3$ )	20 g
Phosphoric acid ( $\text{H}_3\text{PO}_4$ , sp gr 1.69)	50 ml
Water to make	1 liter
Temperature of the mixture	80°C (176°F)
Time in the mixture	6 to 7 minutes
2. Rinse sample in distilled water 6 to 7 minutes
3. Scrub specimens lightly with a bristle brush under running water
4. Rinse specimens in distilled water 6 to 7 minutes
5. Place specimens in methyl alcohol 6 to 7 minutes

After cleaning and weighing the samples after their second exposure (May 23, 1983 to August 1, 1985) at DCSC, 4 exposed and 4 control samples were cleaned again as described above and then weighed. The reason for this second cleaning of these 8 samples was to determine the effect of the cleaning on mass loss.

The loss of mass of the aluminum roofing samples after each of the two exposure periods is given in table A1. The average value of the mass of the control and exposed samples is given for the samples after the first period of exposure and chemical cleaning. It can be seen from the mass loss data in table A1 that there was considerably more loss of mass of the control specimens after the shorter, first exposure, period than for the longer, second exposure, period. This may possibly be due to the initial cleaning of the specimens (acetone and alcohol) not removing as much adhered material from the samples as compared to the chemical cleaning procedure. The estimate of mass loss due to exposure

Table A1. Mass Loss of Aluminum Roofing Samples

Type of Sample	Mass of Samples After First Exposure <sup>1/</sup> (g)		Mass Loss After First Exposure <sup>1/</sup> (g)		Mass Loss After Second Exposure <sup>2/</sup> (g)	
	$\bar{x}_3$	$\sigma_4$	$\bar{x}_3$	$\sigma_4$	$\bar{x}_3$	$\sigma_4$
Control	35.7280	0.4878	0.0055	0.0009	0.0012	0.0003
Exposed	35.9003	0.5554	0.0188	0.0035	0.0485	0.0091

<sup>1/</sup> First exposure period was August 10, 1982 to March 28, 1983 (206 days).

<sup>2/</sup> Second exposure period was May 28, 1983 to August 1, 1985 (797 days).

<sup>3/</sup> Average value of 30 exposed and 26 control samples.

<sup>4/</sup> Standard deviation.

reported herein is therefore based on the second exposure period since the samples were chemically cleaned before and after this exposure period.

The surface area of the 4 x 6 in. (10 x 15 cm) samples is estimated to be 25.14 in.<sup>2</sup> (0.016 m<sup>2</sup>), since the samples have a low profile rib that extends along the center of the longitudinal direction. The average effective width of the samples, including the rib, was determined to be 4.19 in. (10.6 cm) from measurements of six samples. Using data from the second exposure period ( $X = 0.0485$  g) the average rate of mass loss was calculated to be 0.038 mg/dm<sup>2</sup>·day.

It was noted earlier that after cleaning and weighing the samples after the second exposure, 4 exposed and 4 control samples were again chemically cleaned and weighed to determine the effect of cleaning on mass loss. There was essentially no change in mass of the control samples after the second chemical cleaning of the samples from the second exposure, however, for the exposed samples the mass loss averaged 0.0016 g.

### 3.2 MICROSCOPIC EXAMINATIONS

ASTM Standards G1-81 [4] and G48-76 [5] were considered in examining and determining the extent of corrosion. It can be seen from the photograph (figure A3) of a typical exposed and control sample, that the exposed sample on the left has less gloss and greater surface roughness than the control sample on the right. Also, it can be seen that the surface of the exposed sample contains many small dark spots. It is thought that these dark spots

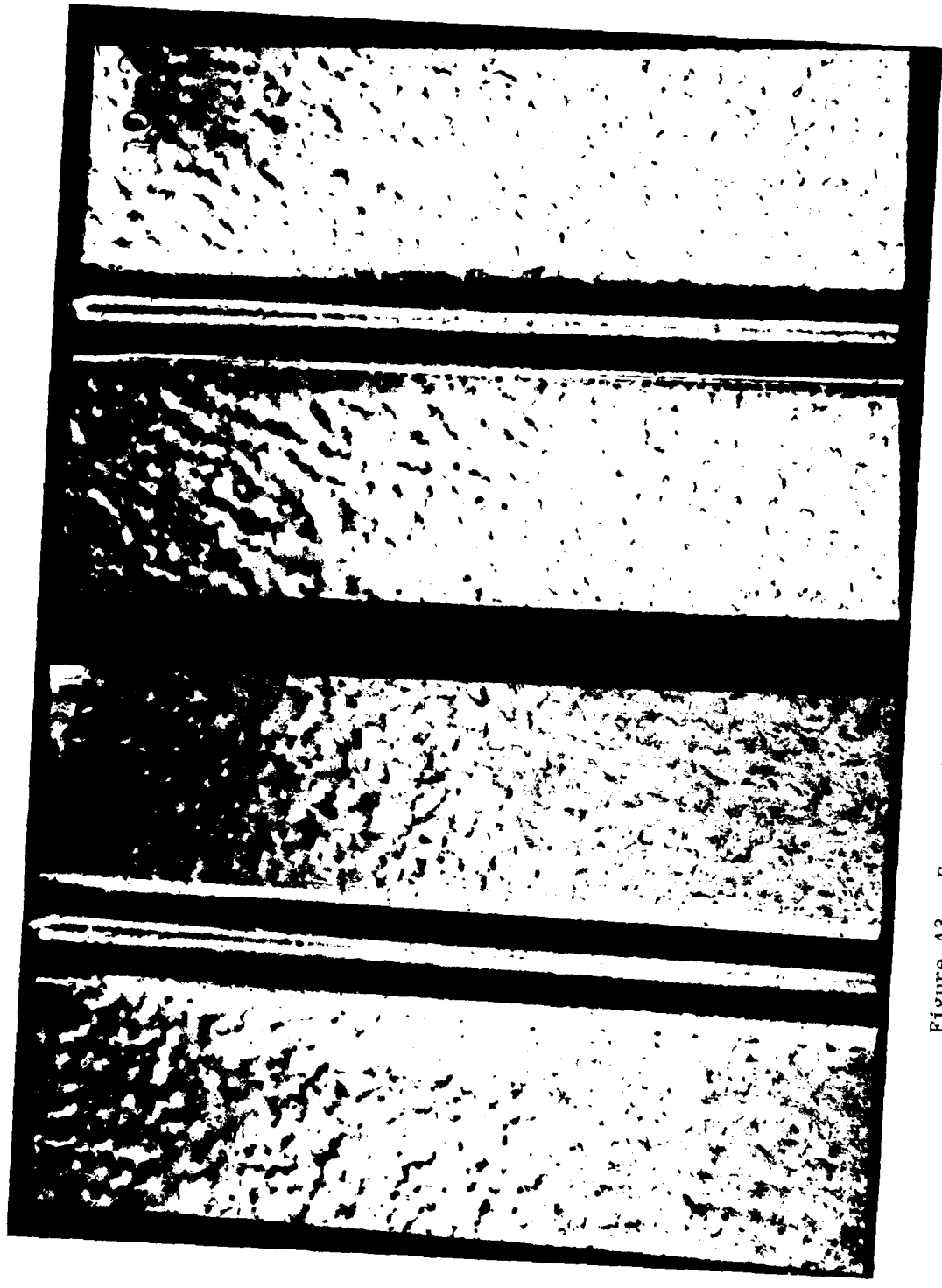

Figure A3. Exposed (left) and control (right) specimens.

represent incipient corrosion. Photomicrographs (10x) of a portion of the surfaces of typical exposed and control samples after the second exposure are presented in figures A4 and A5, respectively. The dark spots on the exposed sample seen in figure A3 are shown in more detail in figure A4. At the dark spots (incipient corrosion) there was essentially no pitting. The total time of outdoor exposure at DCSC of the exposed samples was 33 months and 26 days.



Figure A4. Photomicrograph (10x) of portion of surface area of exposed sample.

Figure A5. Photomicrograph (10x) of portion of surface area of control sample.

#### 4. SUMMARY

Aluminum roofing samples, 4 x 6 in. (10 x 15 cm) in size were exposed to outdoor weathering for nearly three years on a rack mounted on one of the roofs of the buildings at the Defense Construction Supply Center (DCSC) in Columbus, Ohio that were reroofed with an aluminum standing-seam roofing system. The samples were of the same material as the roofing system. The objective of the study was to conduct a preliminary assessment of the extent of corrosion of the aluminum roofing over a period of nearly three years. Changes in mass of the exposed samples were measured and the average rate of corrosion was calculated to be 0.038 mg/dm<sup>2</sup>·day. Photographs and photomicrographs of exposed and control samples indicated a loss of gloss, increased surface roughness, and dark spots (incipient corrosion) at many locations on the surface due to the outdoor exposure. Observations of the surface of the exposed samples indicated that essentially no pitting occurred.

#### REFERENCES

1. Rosenfield, Myer J., "Construction of Aluminum Standing-Seam Roofing at an Army Facility," U.S. Army Corps of Engineers Construction Engineering Laboratory Interim Report M-336, November 1983.
2. "Facilities Engineering Maintenance and Repair of Roofs," Army TM 5-617, Navy NAVFAC MO-113, Air Force AFM 91-31, and Marine Corps MCO P11014.9, January 1974.
3. "Architectural Sheet Metal Manual," Sheet Metal and Air Conditioning Contractors National Association, Inc., Third Edition, Vienna, VA, 1979.
4. "Standard Practice for Preparing, Cleaning, and Evaluating Corrosion Test Specimens," ASTM Designation G1-81, 1982 Annual Book of ASTM Standards, Part 10, American Society for Testing and Materials, Philadelphia, PA.
5. "Standard Recommended Practice for Examination and Evaluation of Pitting Corrosion," ASTM Designation G48-76 (Reapproval 1980), 1981 Annual Book of ASTM Standards, Part 10, American Society for Testing and Materials, Philadelphia, PA.

#### ACKNOWLEDGMENTS

This study was sponsored by the U.S. Army Corps of Engineers Construction Engineering Research Laboratory and the Defense Logistics Agency. Special thanks and appreciation are expressed to Myer J. Rosenfield, CERL, Marvin U. Dubois, DLA, and William J. Smith, DCSC, for their assistance in carrying out this study.

## USA-CERL DISTRIBUTION

<p>Chief of Engineers            ATTN: Tech Monitor            ATTN: DAEN-IMS-L (2)            ATTN: DAEN-CCP            ATTN: DAEN-CW            ATTN: DAEN-CWE            ATTN: DAEN-CWM-R            ATTN: DAEN-CWO            ATTN: DAEN-CWP            ATTN: DAEN-EC            ATTN: DAEN-ECC            ATTN: DAEN-ECE            ATTN: DAEN-ECR            ATTN: DAEN-RD            ATTN: DAEN-RDC            ATTN: DAEN-RDM            ATTN: DAEN-RM            ATTN: DAEN-ZCE            ATTN: DAEN-ZCF            ATTN: DAEN-ZCI            ATTN: DAEN-ZCM            ATTN: DAEN-ZCZ</p> <p>FESA, ATTN: Library 22060            ATTN: DET III 79906</p> <p>US Army Engineer Districts            ATTN: Library (41)</p> <p>US Army Engineer Divisions            ATTN: Library (14)</p> <p>US Army Europe            AEAEN-ODCS/Engr 09403            ISAE 09081            V Corps            ATTN: DEH (11)            VII Corps            ATTN: DEH (15)            21st Support Command            ATTN: DEH (12)            USA Berlin            ATTN: DEH (11)            USASETAF            ATTN: DEH (10)            Allied Command Europe (ACE)            ATTN: DEH (3)</p> <p>8th USA, Korea (19)</p> <p>USA Japan (USARJ)            ATTN: AJEN-DEH 96343            ATTN: DEH-Honshu 96343            ATTN: DEH-Okinawa 96331</p> <p>416th Engineer Command 60623            ATTN: Facilities Engineer</p> <p>US Military Academy 10966            ATTN: Facilities Engineer            ATTN: Dept of Geography &amp;            Computer Science            ATTN: DSCPER/MAEN-A</p> <p>AMMRC, ATTN DRXMR-WE 02172</p> <p>USA ARRCOM 61299            ATTN: DRCIS-RI-1            ATTN: DRSAR-IS</p> <p>AMC - Dir., Inst., &amp; Serve            ATTN: DEH (23)</p> <p>DLA ATTN: DLA-WI 22314</p> <p>DNA ATTN: NADS 20305</p> <p>FORSCOM            FORSCOM Engr, ATTN: AFEN-DEH            ATTN: DEH (23)</p> <p>HSC            ATTN: HSLO-F 78234            ATTN: Facilities Engineer            Fitzsimons AMC 80240            Walter Reed AMC 20012</p> <p>INSCOM - Ch, Instl. Div            ATTN: Facilities Engineer (3)</p>	<p>ROK/US Combined Forces Command 96301            ATTN: EUSA-HHC-CFC/Engr            MDW, ATTN: DEH (3)</p> <p>MTMC            ATTN: MTMC-SA 20315            ATTN: Facilities Engineer (3)</p> <p>NARADCOM, ATTN: DRDNA-F 01760</p> <p>TARCOM, Fac. Div. 48090</p> <p>TRADOC            HQ, TRADOC, ATTN: ATEN-DEH            ATTN: DEH (19)</p> <p>TSARCOM, ATTN: STSAS-F 63120</p> <p>USACC, ATTN: Facilities Engr (2)</p> <p>WESTCOM            ATTN: DEH, Ft. Shafter 96858            ATTN: APEN-IM</p> <p>SHAPE 09055            ATTN: Surv. Section, CCB-OPS            Infrastructure Branch, LANDA</p> <p>HQ USEUCOM 09128            ATTN: ECJ 4/7-LOE</p> <p>FORT BELVOIR, VA 22060 (7)            ATTN: Canadian Liaison Officer            ATTN: British Liaison Officer            ATTN: Australian Liaison Officer            ATTN: French Liaison Officer            ATTN: German Liaison Officer            ATTN: Water Resources Support Ctr            ATTN: Engr Studies Center            ATTN: Engr Topographic Lab.            ATTN: ATZA-DTE-SU            ATTN: ATZA-DTE-EM            ATTN: R&amp;D Command</p> <p>CRREL, ATTN: Library 03755</p> <p>WES, ATTN: Library 39180</p> <p>HQ, XVIII Airborne Corps            and Fort Bragg            ATTN: AFZA-FE-EE 28307</p> <p>Area Engineer, AEDC-Area Office            Arnold Air Force Station, TN 37389</p> <p>Chanute AFB, IL 61868            3345 CES/DE, Stop 27</p> <p>Norton AFB, CA 92409            ATTN: AFRCE-MX/DEE</p> <p>AFESC, Tyndall AFB, FL 32403</p> <p>NAVFAC            ATTN: Engineering Command (7)            ATTN: Division Offices (6)            ATTN: Naval Public Works Center (9)            ATTN: Naval Civil Engr Lab. (3)</p> <p>ATTN: Library, Code L08A NCEL 93043</p> <p>Defense Technical Info. Center 22314            ATTN: DDA (2)</p> <p>Engr Societies Library, NY 10017</p> <p>Natl Guard Bureau Instl. Div 20310</p> <p>US Govt Print Office 22304            Receiving Sect/Depository Copies (2)</p> <p>US Army Env. Hygiene Agency            ATTN: HSHB-E 21010</p> <p>National Bureau of Standards 20899</p>
--	---

EMC Team Distribution

Chief of Engineers 20314  
ATTN: DAEN-ZCF-B  
ATTN: DAEN-ECZ-A  
ATTN: DAEN-ECB (2)  
ATTN: DAEN-ZCP

US Army Engineer District  
New York 10007  
ATTN: Chief, Design Br  
Pittsburgh 15222  
ATTN: Chief, ORPCD  
ATTN: Chief, Engr Div  
Philadelphia 19106  
ATTN: Chief, NAPEN-D  
Baltimore 21203  
ATTN: Chief, Engr Div  
Norfolk 23510  
ATTN: Chief, NAOEN-M  
ATTN: Chief, NAOEN-D  
Huntington 25721  
ATTN: Chief, ORHED-F  
Wilmington 28401  
ATTN: Chief, SAWCO-C  
ATTN: Chief, SAWEN-D  
Charleston 29402  
ATTN: Chief, Engr Div  
Savannah 31402  
ATTN: Chief, SASAS-L  
Jacksonville 32232  
ATTN: Const Div  
Mobile 36628  
ATTN: Chief, SAMEN-D  
ATTN: Chief, SAMEN-F  
ATTN: Chief, SAMEN  
Nashville 37202  
ATTN: Chief, ORNED-F  
Memphis 38103  
ATTN: Chief, Const Div  
ATTN: Chief, LMMED-D  
Vicksburg 39180  
ATTN: Chief, Engr Div  
Louisville 40201  
ATTN: Chief, Engr Div  
Detroit 48231  
ATTN: Chief, NCEED-T  
St. Paul 55101  
ATTN: Chief, ED-D  
ATTN: Chief, ED-F  
Chicago 60604  
ATTN: Chief, NCCC0-C  
ATTN: Chief, NCCED-F  
Rock Island 61201  
ATTN: Chief, Engr Div  
ATTN: Chief, NCRED-F  
St. Louis 63101  
ATTN: Chief, ED-D  
Kansas City 64106  
ATTN: Chief, Engr Div  
Omaha 68102  
ATTN: Chief, Engr Div  
New Orleans 70160  
ATTN: Chief, LMNED-DG  
Little Rock 42203  
ATTN: Chief, Engr Div  
Tulsa 74102  
ATTN: Chief, Engr Div  
Ft. Worth 76102  
ATTN: Chief, SWFED-D  
ATTN: Chief, SWFED-F  
Galveston 77550  
ATTN: Chief, SWGAS-L  
ATTN: Chief, SWGCO-C  
ATTN: Chief, SWGED-DC  
Albuquerque 87103  
ATTN: Chief, Engr Div  
Los Angeles 90053  
ATTN: Chief, SPLED-F  
San Francisco 94105  
ATTN: Chief, Engr Div  
Sacramento 95814  
ATTN: Chief, SPKED-D  
ATTN: Chief, SPKCO-C  
Far East 96301  
ATTN: Chief, Engr Div

US Army Engineer District  
Portland 97208  
ATTN: Chief, DB-6  
ATTN: Chief, FM-1  
ATTN: Chief, FM-2  
Seattle 98124  
ATTN: Chief, NPSCO  
ATTN: Chief, NPSEN-FM  
ATTN: Chief, EN-DB-ST  
Walla Walla 99362  
ATTN: Chief, Engr Div  
Alaska 99501  
ATTN: Chief, NPASA-R

US Army Engineer Division  
New England 02154  
ATTN: Chief, NEDED-T  
ATTN: Laboratory  
ATTN: Chief, NEDCD  
Middle East (Rear) 22601  
ATTN: Chief, MEDED-T  
North Atlantic 10007  
ATTN: Chief, NADEN  
South Atlantic 30303  
ATTN: Laboratory  
ATTN: Chief, SADEN-TC  
ATTN: Chief, SADEN-TS  
Huntsville 35807  
ATTN: Chief, HNDED-CS  
ATTN: Chief, HNDED-M  
ATTN: Chief, HNDED-SR  
Lower Mississippi 39180  
ATTN: Chief, LMVED-G  
Ohio River 45201  
ATTN: Laboratory  
ATTN: Chief, Engr Div  
Missouri River 68101  
ATTN: Chief, MRDED-G  
ATTN: Laboratory  
Southwestern 75202  
ATTN: Laboratory  
ATTN: Chief, SWDED-MA  
ATTN: Chief, SWDED-TG  
South Pacific 94111  
ATTN: Laboratory  
Pacific Ocean 96858  
ATTN: Chief, Engr Div  
ATTN: FM&S Branch  
ATTN: Chief, PODED-D  
North Pacific 97208  
ATTN: Laboratory  
ATTN: Chief, Engr Div

6th US Army 94129  
ATTN: AFKC-EN

7th US Army 09407  
ATTN: AETTM-HRD-EHD

HQ, Combined Field Army (ROK/US) 96358  
ATTN: CFAR-EN

HQDA SGRD-EDE 20314

US Army Foreign Science and  
Tech Center  
ATTN: Charlottesville, VA 22901  
ATTN: Far East Office 96328

USA ARRADCOM 07801  
ATTN: DRDAR-LCA-OK

HQ, USAMRDC  
ATTN: SGRD-PLC  
Fort Detrick, MD 21701

West Point, NY 10996  
ATTN: Dept of Mechanics  
ATTN: Library

Ft. Belvoir, VA 22060  
ATTN: ATSE-TD-TL (2)  
ATTN: Learning Resource Center

Ft. Benning, GA 31905  
ATTN: ATZB-FE-EP  
ATTN: ATZB-FE-BC

Ft. Leavenworth, KS 66627  
ATTN: ATZLCA-SA

Ft. Lee, VA 23801  
ATTN: DRXMC-D (2)

Ft. McPherson, GA 30330  
ATTN: AFEN-CD

Ft. Monroe, VA 23651  
ATTN: ATEN-AD (3)  
ATTN: ATEN-FE-ME  
ATTN: ATEN-FE-EN (2)

Ft. Richardson, AK 99505  
ATTN: AFZT-FE-E

Rocky Mountain Arsenal 80022  
ATTN: SARRM-CO-FEP

USA-WES 39180  
ATTN: C/Structures  
ATTN: Soils & Pavements Lab

Naval Facilities Engr Command 22332  
ATTN: CODE 2013 C

COMMANDER (CODE 2636) 93555  
Naval Weapons Center

Little Rock AFB  
ATTN: 314/DEEE

Bldg. Research Advisory Board 20418

Dept of Transportation Library 20590  
Transportation Research Board 20418

Division of Building Research  
National Research Council  
Ottawa, Ontario, Canada K1A 0R6

133  
7/86

END

12-86

DTIC