

MICROCOPY RESOLUTION TEST CHART
NATIONAL BUREAU OF STANDARDS 1963-A

AD-A173 392

USA-CERL

US Army Corps
of Engineers
Construction Engineering
Research Laboratory

TECHNICAL REPORT M-86/18
August 1986
Rapidly Erectable and Relocatable
Lightweight Structures

Laboratory Testing of Internal Bracing Systems for a Lightweight Relocatable Structure

by
Anthony M. Kao
Steven C. Sweeney

DTIC
SELECTED
OCT 23 1986
S D D

This report documents laboratory testing and evaluation of internal lateral bracing schemes for use in commercially available, off-the-shelf lightweight relocatable structures (LRS) selected for possible military application in a Theater of Operations (TO). The structural system used for the test was a panelized building manufactured by Kelly Klosure, Inc. The purpose of this study was to find a way to eliminate the guy wires currently incorporated in this LRS. To be acceptable, a bracing scheme had to satisfy Army facilities Component System design criteria for initial construction (0 to 6 months) and be easy to incorporate into the building system.

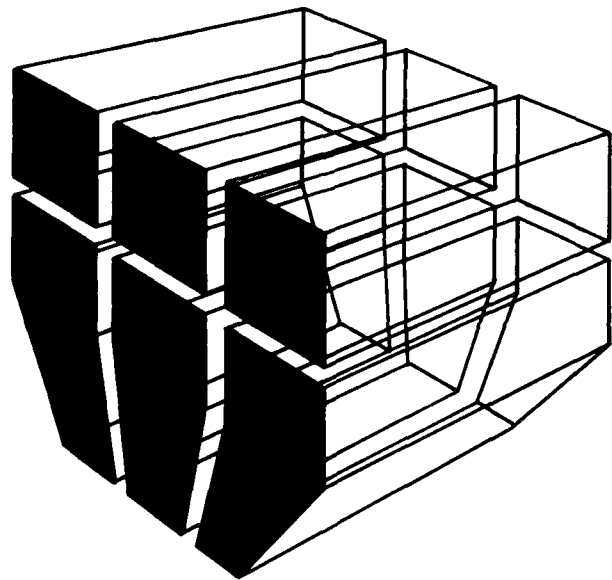

Three bracing schemes were tested, and all satisfied loading requirements. One of these systems is not yet commercially available. The other two systems (a wood knee brace and a steel knee brace) developed by the U.S. Army Construction Engineering Research Laboratory (USA-CERL) can be easily fabricated with commercially available materials. Although all systems tested increase construction time, cost, and logistics somewhat, they are better adapted to various soil conditions and occupy less space when constructed.

DTIC FILE COPY

Approved for public release; distribution unlimited.

86 10 21 081
86 10 21 081

UNCLASSIFIED

SECURITY CLASSIFICATION OF THIS PAGE (When Data Entered)

REPORT DOCUMENTATION PAGE		READ INSTRUCTIONS BEFORE COMPLETING FORM
1. REPORT NUMBER CERL TR M-86/18	2. GOVT ACCESSION NO.	3. RECIPIENT'S CATALOG NUMBER
4. TITLE (and Subtitle) LABORATORY TESTING OF INTERNAL BRACING SYSTEMS FOR A LIGHTWEIGHT RELOCATABLE STRUCTURE		5. TYPE OF REPORT & PERIOD COVERED Final
		6. PERFORMING ORG. REPORT NUMBER
7. AUTHOR(s) Anthony M. Kao Steven C. Sweeney		8. CONTRACT OR GRANT NUMBER(s)
9. PERFORMING ORGANIZATION NAME AND ADDRESS U.S. Army Construction Engr Research Laboratory P.O. Box 4005 Champaign, IL 61820-1305		10. PROGRAM ELEMENT, PROJECT, TASK AREA & WORK UNIT NUMBERS 4A162731AT41-E-049
11. CONTROLLING OFFICE NAME AND ADDRESS		12. REPORT DATE July 1986
		13. NUMBER OF PAGES 49
14. MONITORING AGENCY NAME & ADDRESS (if different from Controlling Office)		15. SECURITY CLASS. (of this report) UNCLASSIFIED
		15a. DECLASSIFICATION/DOWNGRADING SCHEDULE
16. DISTRIBUTION STATEMENT (of this Report) Approved for public release; distribution unlimited.		
17. DISTRIBUTION STATEMENT (of the abstract entered in Block 20, if different from Report)		
18. SUPPLEMENTARY NOTES Copies are available from the National Technical Information Service Springfield, VA 22161		
19. KEY WORDS (Continue on reverse side if necessary and identify by block number) lightweight relocatable structures test and evaluation Kelly Klosure bracing system prefabricated building		
20. ABSTRACT (Continue on reverse side if necessary and identify by block number) This report documents laboratory testing and evaluation of internal lateral bracing schemes for use in commercially available, off-the-shelf lightweight relocatable structures (LRS) selected for possible military application in a Theater of Operations (TO). The structural system used for the test was a panelized building manufactured by Kelly Klosure, Inc. The purpose of this study was to find a way to eliminate the guy wires currently incorporated in this LRS. To be acceptable, a bracing scheme had to satisfy Army Facilities Component System design criteria for initial construction (0 to 6 months) and be easy to incorporate into the building system.		

DD FORM 1 JAN 73 1473 EDITION OF 1 NOV 65 IS OBSOLETE

UNCLASSIFIED

SECURITY CLASSIFICATION OF THIS PAGE (When Data Entered)

UNCLASSIFIED

SECURITY CLASSIFICATION OF THIS PAGE(When Data Entered)

BLOCK 20 (Cont'd)

Three bracing schemes were tested, and all satisfied loading requirements. One of these systems is not yet commercially available. The other two systems (a wood knee brace and a steel knee brace) developed by the U.S. Army Construction Engineering Research Laboratory (USA-CERL) can be easily fabricated with commercially available materials. Although all systems tested increase construction time, cost, and logistics somewhat, they are better adapted to various soil conditions and occupy less space when constructed.

UNCLASSIFIED

SECURITY CLASSIFICATION OF THIS PAGE(When Data Entered)

FOREWORD

This research was performed for the Office of the Assistant Chief of Engineers (OACE), under Project 4A162731AT41, "Military Facilities Engineering Technology"; Task Area E, "Military Engineering"; Work Unit 049, "Rapidly Erectable and Relocatable Lightweight Structures." The work was performed by the Engineering and Materials Division (EM), U.S. Army Construction Engineering Research Laboratory (USA-CERL). The OACE Technical Monitors were Dr. Clemens Meyer (DAEN-ZCM) and Mr. Michael Shama (DAEN-ZCM).

Dr. A. Kao was the USA-CERL Principal Investigator. Dr. R. Quattrone is Chief of USA-CERL-EM. COL Paul J. Theuer is Commander and Director of USA-CERL, and Dr. L. R. Shaffer is Technical Director.

Accession For	
NTIS CRA&I	<input checked="" type="checkbox"/>
DTIC TAB	<input type="checkbox"/>
Unannounced	<input type="checkbox"/>
Justification	
By	
Distribution/	
Availability Codes	
Dist	Avail and/or Special
A-1	



CONTENTS

	Page
DD FORM 1473	1
FOREWORD	3
LIST OF TABLES AND FIGURES	5
1 INTRODUCTION	7
Background	
Objective	
Approach	
Mode of Technology Transfer	
2 KELLY KLOSURE SYSTEM	9
AFCS Building System Requirements	
Kelly Klosure Description	
Construction and Erection Procedures	
3 TEST PROGRAM	11
Bracing Systems	
Load Analysis	
Test Configuration	
Test Programs and Instrumentation	
4 RESULTS AND ANALYSIS	14
Constructability	
Load Capacity	
Roof	
Foundation	
Logistics	
Cost	
Summary	
5 CONCLUSIONS AND RECOMMENDATIONS	18
METRIC CONVERSION FACTORS	18
TABLES AND FIGURES	19
APPENDIX: Applied Loads and Wall Deflections	45
DISTRIBUTION	

TABLES

Number		Page
1	Material Costs for Galvanized Steel and Fiberboard Panel Structures	19
2	System Costs for 20- x 8- x 40-ft Structure	19
3	Logistics Requirements: System A	19
4	Logistics Requirements: System B	20
5	Logistics Requirements: System C	20
6	Cost Estimate System A	21
7	Cost Estimate System B	22
8	Cost Estimate System C	23
9	Test Results Summary	23

FIGURES

1	Panel Racks	24
2	System A Assembly	24
3	Framing Anchor	25
4	System A Dimensions	25
5	Lateral Bracing of Chords	26
6	System B Assembly	26
7	System B Dimensions	27
8	System C U-Bolt Connector	27
9	System C Frame	28
10	System C Column Base	28
11	Average Wind Force Coefficients	29
12	Locally Severe Wind Force Coefficients	29
13	Load Frame	30
14	Roller Plate in Place	30

FIGURES (Cont'd)

Number		Page
15	Hydraulic Ram and Pump	31
16	Windward Loading	31
17	Leeward Loading	32
18	Equipment Rack	32
19	Uplift Load Scheme	33
20	Pulley System	33
21	Sandbag Loading	34
22	Position Transducer	34
23	Load Application and Deflection Readings	35
24	Flattened Chord Bracket and Stiffback	36
25	Double Angle Connection	37
26	Column to Rafter Connection	37
27	Wind Speed Vs. Lateral Force	38
28	System A Test Results	38
29	Test 1 Failure	39
30	System A Failure	39
31	Leeward Framing Anchor Failure	40
32	System B Test Results	40
33	System B Deflection	41
34	System C Failure	41
35	System C Test Results	42
36	Total Load Vs. Wind Speed--Roof Test	42
37	Roof Test Results	43
38	Roof Test Failure	43
39	Sandbag Foundation	44

LABORATORY TESTING OF INTERNAL BRACING SYSTEMS FOR A LIGHTWEIGHT RELOCATABLE STRUCTURE

1 INTRODUCTION

Background

The Army Facilities Component System (AFCS) provides facilities for two different construction standards: initial (0 to 6 months) and temporary (up to 24 months). Most AFCS systems are designed to meet the temporary structure standard requirements. However, the Army also needs building types that are appropriate for initial standard construction and can also meet the temporary standard.

A previous study by the U.S. Army Construction Engineering Research Laboratory (USA-CERL) identified and evaluated Lightweight Relocatable Structures (LRS) that meet AFCS initial requirements.¹ Of the systems evaluated, the Kelly Klosure building system was selected as being most suitable for military Theater of Operations (TO) applications.

The next phase of the study field-tested the Kelly Klosure LRS to evaluate erection procedures and determine system constructability, durability, and habitability. The first part of the field testing was done in a desert environment,² and the second part was done in a temperate environment.³ The tests identified various problems, and modifications were suggested to improve system performance. The problem of greatest concern was the use of the guy wire bracing system in various soil conditions. In loose soils, the ground anchor provided inadequate uplift resistance, while in hard, rocky soils the anchor could not be driven deeply enough. Furthermore, the guy wires required additional space and posed a safety hazard. Elimination of these guy wires would improve the system's adaptability to different conditions.

Objective

The objective of this study was to develop an internal lateral bracing scheme that could (1) replace the guy wires in the Kelly Klosure LRS structure, (2) satisfy AFCS design criteria, and (3) be easily incorporated into a building system.

¹A. M. Kao, et al., *Evaluation of Lightweight Relocatable Structures for Use in Theaters of Operation*, Technical Report M-314/ADA117038 (U.S. Army Construction Engineering Research Laboratory [USA-CERL], 1982).

²A. M. Kao, et al., *Field Testing of a Lightweight Relocatable Structure on a Desert Environment*, Technical Report M-361/ADA148841 (USA-CERL, 1984).

³A. M. Kao, et al., *Field Testing of a Lightweight Relocatable Structure in a Temperate Environment*, Technical Report M-85/10/ADA155171 (USA-CERL, 1985).

Approach

Structural loads were determined using the American National Standards Institute's (ANSI) minimum design loads standards.⁴ Three different bracing schemes were chosen as possible solutions to the problems. USA-CERL developed two of the systems, and Kelly Klosure developed a third. Worst case loadings were determined, and each structure was then laboratory-tested for ultimate load resistance. Cost, logistics, and constructability of each system were also evaluated.

Mode of Technology Transfer

It is recommended that the results of the field test be incorporated into Army Technical Manuals 5-301, 5-302, and 5-303.⁵

⁴ANSI A58.1-1982, *American National Standard Minimum Design Loads for Buildings and Other Structures* (American National Standards Institute, 1982).

⁵Technical Manual (TM) 5-301, *Army Facilities Component System—Planning* (Headquarters, Department of the Army [HQ DA], March 1982); TM 5-302, *Army Facilities Component—Design* (HQ DA, March 1982); TM 5-303, *Army Facilities Component System—Logistics Data and Bills of Materials* (HQ DA, March 1982).

2 KELLY KLOSURE SYSTEM

AFCS Building System Requirements

The major concern in LRS systems development has been their capability to be field-erected in the TO. The system must be easy to ship and erect in the field and must be able to be modified to meet climatic or other TO demands. An AFCS system must satisfy the following criteria for standardized construction:

1. Minimize the time needed to erect building components
2. Minimize weight and volume logistical requirements
3. Be container-compatible
4. Minimize construction costs
5. Minimize construction skills and required equipment and maximize simplicity of erection components.

Technical objectives of a potential system include:

1. Compatibility with existing AFCS interior design
2. Ease of relocation
3. Ease of adaption to different climatic conditions
4. Adequate shelf life.

Any adaptations to LRS systems must also be evaluated by these criteria.

Kelly Klosure Description

The Kelly Klosure System is a modular panelized system, based on a 1-1/2- x 1-1/2- x 1/8-in.* steel frame panel. The basic panel sizes are 4 x 4 ft, 4 x 8 ft, and 4 x 12 ft, and they come in galvanized steel, structural fiberboard, and fiberglass. Corrugated galvanized steel panels made from 28-gauge corrugated steel were used for the test. Each 4- x 8-ft panel weighs 61 lb.

The panel frame, eave angles, corner angles, ridge angles, and chord brackets are all made of M1020 merchants bar steel. Other building components include 2- x 6-in. wood chords, a 2- x 6-in. wood baseplate, lag bolts, guy wire system, and Kelly Klosure keys made of zinc-plated steel. The system is "keyed" together, eliminating most nuts and bolts; this allows quick erection and takedown times. Since all the components interconnect readily, a variety of configurations may be assembled with different sizes of panels. Thus, a large variety of building sizes could be provided in a TO environment in a short time. The system is shipped in a storage rack of 24 to 30 panels, with

*Metric conversion factors are provided on p 18.

additional components strapped on top (Figure 1)*. Table 1 gives material costs for both galvanized steel and fiberboard panels used in typical 20- x 8- x 40-ft and 20- x 12- x 40-ft buildings.

Construction and Erection Procedures

The Kelly Klosure systems can be erected directly on unfinished ground, a concrete slab, or a suitable raised wood foundation. Appendix A of USA-CERL Technical Report M-361 provides details of the construction and erection procedures for the standard structure. Modifications to these procedures required for use of the alternative bracing schemes are provided in this report.

*Tables and figures begin on p 19.

3 TEST PROGRAM

Bracing Systems

Three alternate bracing designs were tested. USA-CERL developed Systems A and B (a wood knee brace and a steel angle knee brace, respectively); Kelly Klosure developed System C--a steel gable support with knee braces. The standard roof system was also tested independently for resistance to uplift loads caused by severe wind forces.

System A

The wood knee brace design consists of 2 x 4 knee braces fastened to the standard 2 x 6 chord member and to the 2 x 6 stiffback members added to the system. Figure 2 shows the assembly of System A. The knee is bolted to each 2 x 6 by a single 3/8- x 3-1/2-in. bolt with washers. The stiffback is fastened to the panel at the top using the Kelly Klosure flattened chord bracket, at the midsection using a 2 x 6 stiffback clamp, and at the bottom using 1-1/2-in. framing anchor that resists both shear and axial forces (Figure 3). Figure 4 shows the actual dimensions of the knee brace components.

Further modifications to the standard system include addition of a 2 x 8 base plate to provide adequate area for the panel and stiffback. Also, the 2 x 6 chord member must be braced at midspan over the structure's entire length. This can be done with any number of 2 x 4 members that are run the length of the structure and nailed to the top of each chord member (Figure 5).

System B

The steel knee brace incorporates double 1-1/2- x 1-1/2- x 1/8-in. steel angle braces. Knee angles are bolted through predrilled holes to the inside edge of the wall and roof panels. Also, a double-angle ridge brace is bolted between the two roof panels. Figure 6 is an assembly drawing of one 4-ft section. The chord and stiffback members used in System A are also used in this system. The stiffback increases the wall panel stiffness, while the chord helps distribute lateral loads in the structure. Figure 7 shows dimensions of the steel angle braces.

Additional modifications to the standard system include use of a 2 x 8 base plate instead of a 2 x 6 base plate. Also, the 20-ft chord members must be laterally braced as in System A.

System C

The third system uses 7-1/2- x 2-3/4-in. cold-rolled steel C-sections. Special U-bolt connectors (Figure 8) connect these sections directly to the panels. The sections are bolted together at the ends and braced with a 2- x 2- x 1/8-in. angle (Figure 9). A steel plate welded to the end of the column pieces is secured to the base plate with two 3/8-in. lag bolts (Figure 10). This system requires a 2 x 12 base plate to support the panel and column base. The 20-ft chord member and the chord brackets to attach it are eliminated. System C is still under development by Kelly Klosure and is not currently available.

Load Analysis

Pressure coefficients for wind forces were taken to obtain the average loads on the main wind-force-resisting systems. The windward wall was assumed to have a uniform pressure calculated at the mean roof height of 10 ft. The basic ANSI equation for wind pressure is:

$$q = 0.00256 K_z (IV)^2 \quad [\text{Eq 1}]$$

where: q = velocity pressure calculated at mean roof height
 K_z = exposure coefficient
 I = importance factor
 V = basic wind speed.

For a temporary structure less than 15 ft tall, both K_z and I are 1. The velocity pressure is used to calculate design pressure:

$$p = qG_h C_p - q(GC_{pi}) \quad [\text{Eq 2}]$$

where: p = design pressure (psf)
 q = velocity pressure (from Eq 1)
 G_h = gust response factor
 C_p = external pressure coefficient
 GC_{pi} = internal pressure coefficient.

For open terrain with scattered obstructions, G_h is 1.32. Values of internal pressure coefficients can vary from +0.75 to -0.25; however, this will not affect the total lateral force on the structure.

External pressure coefficients are based on the structure's geometry. Figure 11 shows values of C_p for the Kelly Klosure 20-ft gable building. Instances of locally high wind pressures must also be included when considering the performance of individual components and cladding. These factors act on the roof and around the corners of the structure. Figure 12 shows the high localized roof pressures considered significant for certain building configurations.

AFCS requires that buildings with a life expectancy of less than 5 years be designed for a basic wind speed equal to 50 mph.⁶ Therefore, the 50-mph static load requirement was set as the minimum acceptable force resistance for this test. Snow loads were also considered, but were determined to be insignificant to the critical loading conditions.

Test Configuration

Each bracing system was subjected to full-scale load testing. Single 4-ft-wide, 8-ft-high bay sections were tested in a special load frame erected for the test (Figure 13). Sections were constructed outside the frame and lifted into place with an overhead crane. Boundary conditions along the panel's edges were satisfied using plates mounted with rollers (Figure 14). These plates were bolted to the panels at the top of

⁶ANSI A58.1-1982.

the wall and at the peak of the roof. With the rollers bearing on smooth plywood sheets, sideways and twisting were prevented while allowing for lateral and vertical displacement from the loading.

Test Programs and Instrumentation

Load Application

Lateral forces were applied to both windward and leeward walls with hydraulic rams operated by a hand pump (Figure 15). Load was applied to the windward wall at the middle and top of the panel (Figure 16) and to the middle of the stiffback or column on the inside of the leeward wall (Figure 17). Load was measured with BLH load cells model V3G1 (10,000-lb capacity). Loads were monitored and recorded with an HP 9825A calculator, HP 3455 digital voltmeter, and HP 3495A scanner (Figure 18).

Uplift forces had to be applied so as to apply a constant load while allowing for all building deflections. The loading scheme shown in Figure 19 applied a four-point uniform load to each roof section. The cable and pulley system, combined with the sandbag gravity loads (Figures 20 and 21), gave the system the required flexibility. The sandbags were weighed prior to testing, and loads were recorded manually.

Failure for this test was defined as breaking or buckling of a force-resisting component. Failure was also defined as excessive deflection of the structure beyond the test equipment's loading capabilities. Loads were applied linearly at an approximate rate of 98 lb lateral load per minute until failure occurred.

Displacements

Displacements under load were measured at the top of both the windward and leeward wall sections. Position transducers were mounted to the load frame perpendicular to the wall sections (Figure 22). Deflection data were monitored and recorded with the same equipment as the load data. Figure 23 is a schematic of load application and deflection readings for the various tests.

4 RESULTS AND ANALYSIS

Constructability

Each test frame was assembled and disassembled by one or two people. Only single-bay sections were erected at one time. The following information on the constructability of each system includes details for assembling and erecting the systems.

System A

All lumber for System A can be prefabricated or cut and drilled onsite.

The 8-ft frame is assembled as specified for a 12-ft wall structure, including the 2 x 6 stiffbacks and flattened chord brackets (Figure 24). The stiffback clamps are nailed in place and the knee braces bolted to the chord and stiffback. All parts readily fit the building system.

When erecting sections for the testing, the braced frames give additional stiffness, reducing twisting and chance of damage to building components. After the section is keyed in place, the stiffback is nailed to the base plate using the framing anchor and the panel lag-bolted to the base plate as usual. If the lumber is prefabricated, about 3 extra manhours are required to assemble the 20- x 40-ft structure; however, eliminating guy wires⁷ saves 3 manhours, resulting in no increase in net construction time. To cut and drill material on site takes an additional 6 manhours.

System B

As with System A, both the wood stiffbacks and the chords for System B can be prefabricated or made on-site. The steel angles are difficult to cut and drill in the field and are best suited for prefabrication. The steel angles bolt through predrilled holes in the panel frames, so the panels do not have to be modified.

Each bay section is assembled as specified in the erection guide, except that assembly includes the 8-ft stiffbacks, using the flattened chord brackets and stiffback clamps. The bay section is rotated into place and keyed to previously erected sections. The double knee braces and ridge brace are then fastened to the panel joint (Figure 25). The stiffback is finally nailed to the base plate using the framing anchors, and the panel is lag-bolted to the base plate. An estimated 2 extra manhours are required to install this system in a 40-ft-long building. There were no compatibility problems with the building system during the testing.

System C

All parts for System C were prefabricated. The standard panels did not have to be modified for the testing.

The outer frame of the building is assembled with no chord brackets or wood members. Next, the steel C-sections are connected to the wall and roof panel frames using the special U-bolt connectors. The C-sections are bolted together with single bolts through predrilled holes (Figure 26). The steel knee and ridge braces are then bolted in

⁷TM 5-301.

place. The frame is rotated onto the base plate and keyed in place, and finally, the base of the columns and wall panels are lag-bolted to the base plate.

The modified frame was found to be compatible with the building system. This frame was intended for use in every other bay section, so only five frames would be needed for the structure. However, laboratory tests showed that 12-ft frame spacing would be adequate, thus decreasing the number of required frames to four. The weight of the sections caused construction problems. Rotating the frame onto the base plate, which was done with an overhead crane, caused severe twisting on the bay section. Although there was no damage to the panels, the ridge brace buckled. Therefore, temporary ridge braces were installed to lift the section into place and later removed. When upright, the system is unstable until fastened into place. An estimated 3 extra manhours are required to install this system in a 40-ft building.

Load Capacity

System A

System A was tested under lateral loads only, with lateral roof forces applied to the top of the wall panel. Four tests were performed: tests 1, 2, and 3 used all new panels and wood members, while test 2a replaced only the failed member from test 2. The Appendix gives actual loads applied in all tests and the resultant wall deflections.

To determine a corresponding wind for each load, total lateral force on the frame was computed using both test and design loadings. Figure 27 shows lateral force vs. wind speed. Actual forces under test loads were calculated by summing the windward and leeward applied forces. The corresponding wind speed is that which produces the same lateral force as the test loads.

Figure 28 gives wind speed vs. deflection results for all four tests. The average maximum wind speed was 66.6 mph, with a low value in test 1 of 62.4 mph. Maximum deflection before failure occurred in test 2 at 8.16 in., with an average deflection of 7.4 in. Failure in test 1 occurred when the framing anchor at the windward wall pulled away from the base plate (Figure 29). This showed that an anchor providing both axial and shear resistance was needed. Failure for tests 2, 2a, and 3 occurred when the 2 x 6 stiffback on the windward wall split at the flattened chord bracket connection (Figure 30). At maximum deflection, the leeward stiffback pulled out of the framing anchor (Figure 31).

System B

System B was tested under a combination of lateral and uplift forces. Three tests were performed on the system; all three used new materials. The Appendix gives the actual loads applied on each test and the deflections for tests 1 and 3. No deflection readings were recorded for test 2. To determine corresponding wind speed for each load increment, the lateral force on the frame was calculated by the equation:

$$F = W_w + L_w + (L_R - W_R) \sin 24^\circ \quad [\text{Eq 3}]$$

where:

- F = lateral force on frame (lb)
- W_w = applied load on windward wall (lb)
- L_w = applied load on leeward wall (lb)
- L_R = applied load on leeward roof (lb)
- W_R = applied load on windward roof (lb).

Kelly Klosure literature shows a roof pitch of 4 in 12, or 18 degrees; however, actual measurement of the roof angle is 24 degrees. The corresponding wind speed is determined from the lateral force, using the 4-ft spacing curve shown in Figure 27. Figure 32 shows wind speed vs. deflection for tests 1 and 3.

System B failed because of excess deflection in roof and wall panels. The large deflections are evident in Figure 33. The average maximum wind speed for the three tests was 83.4 mph, with a low value of 77.3 mph occurring in test 1. Maximum deflection measured was 15.9 in., with an average for tests 1 and 3 of 13 in.

System C

System C was tested under a combination of lateral and uplift forces. One frame (provided by Kelly Klosure) was tested. The Appendix provides the actual loads applied during the test. Lateral force for the frame was calculated using Eq 3. Since this frame was intended to be used every 8 ft, it had to support twice the tributary area and thus carry twice the load. Figure 27 shows the wind speed vs. lateral force for the 8-ft frame spacing.

Loading in this test was so large that the plate, which had been modified for the required 12-in. width, did not adequately hold the column foot. Loading caused failure in the leeward knee brace (Figure 34) corresponding to a wind speed of 79.6 mph, producing a deflection of 3.65 in. Given the high strength of the system, it is possible to use one frame every 12 ft. Figure 27 shows the wind speed vs. lateral force for 12-ft spacing. Maximum wind speed for 12-ft spacings would be 65.0 mph. Therefore, analysis of this system assumes 12-ft brace spacing. Figure 35 shows wind speed vs. deflection results for System C, assuming 4-, 8-, and 12-ft frame spacing.

Roof

The roof, which was tested under uplift loads only, was subjected to forces corresponding to high pressures caused by unsteady air flow. Vertical deflections at the middle of the roof sections were recorded manually. Figure 36 shows total load vs. wind speed. Three tests were performed; the Appendix provides the test results, and Figure 37 gives wind speed vs. deflection curves for each test. Average ultimate wind speed was 60.8 mph, with a low value of 57.2 mph. Maximum deflection measured was 7.1 in. All three test failures occurred when the 4-ft eave angle buckled at a key connection (Figure 38).

Foundation

Analysis of the three systems shows that when erected with the base plate on bare ground, the 18-in. ground stake is inadequate to resist uplift forces in most soils. Ground stakes must still be used to prevent lateral movement. However, additional uplift resistance must be added.

A single row of sandbags, placed on the base plate around the entire inside perimeter of the structure, will prevent movement. One sandbag per foot, or about 120 sandbags, are needed (Figure 39). Assuming 1 manhour to place 25 sandbags, 4.8 extra manhours are required for foundation work. For structures bolted to a concrete or wood floor, no additional weight is required.

Logistics

Weight and volume must be minimized to best satisfy AFCS logistics criteria. The basic structure weighs 4871 lb and occupies 273 cu ft. The panel racks shown in Figure 1 allow for easy relocation and storage of the structures.

System A

Table 3 gives the additional weight and volume requirements of System A. For a 20- x 40-ft structure, an additional 607.4 lb of material are required, which adds 16 cu ft of volume. The lumber can be stacked easily on skids, and all accessories can be tied to the tops of panel racks with the original building components.

System B

Table 4 provides a breakdown of added weight and volume requirements for System B. Weight is increased by 853.2 lb, and 14.2 cu ft are added to the volume. The lumber can be stacked easily for transportation, and fasteners and steel angles can be strapped to the top of the panel racks.

System C

Table 5 gives the added weight and volume requirements for System C. Weight is increased by 367 lb, and 17.5 cu ft of volume are added. The steel C-sections can be stacked on a pallet, and all fasteners can be tied to the tops of the panel racks with the other building accessories.

Cost

The cost for the basic 20- x 8- x 40-ft galvanized steel structure is \$5626.18 (Table 2). Adding the cost of lumber for the base plate and chord members (\$115.20) brings the total to \$5741.38. Tables 6, 7, and 8 provide a detailed cost breakdown for each system. System A has the lowest cost (\$5818.53), while System C is the most expensive at \$6725.12. All Kelly Klosure costs include a 20 percent General Services Administration (GSA) discount. Other materials costs are from suppliers. Costs are correct as of August 1985.

Summary

Table 9 compares all test results. Construction times for the basic structure were recorded in field tests at Fort Irwin, CA.⁸ Construction, logistics, and cost data are given as totals for the entire 20- x 8- x 40-ft structure. Deflections were compared at the 50-mph wind level. All systems satisfied the minimum load requirements.

Of the three, System A is the best bracing system. It rates first or second in all five categories shown in Table 9, including the lowest cost and shortest erection time. Furthermore, System A is the easiest to erect and is best suited for field fabrication. None of the systems show a clear logistical advantage over the others. System C did show a greater stiffness than A; however, it is difficult to erect and more expensive.

⁸TM 5-301.

5 CONCLUSIONS AND RECOMMENDATIONS

Laboratory test results support the use of internal lateral bracing schemes to replace guy wires in LRS. The three systems tested all withstood at least a 60-mph design wind load, satisfying the AFCS 50-mph requirement for structures erected for less than 5 years. System C proved to be the stiffest frame, deflecting 2.6 in. under a 50-mph load.

When these systems are constructed on bare ground, the base plate must be weighted to provide adequate uplift resistance. A single row of sandbags placed on the base plate over the entire inside perimeter will provide adequate uplift resistance. No additional weight is required for structures built on concrete slabs or wood floors.

All three systems are well suited for use of prefabricated components. System A, with nonstandard components of wood only, is best suited for field fabrication. System A also provided the most stiffness in sections during construction and was easiest to erect. Use of these systems does not significantly increase the building's construction time.

Volume requirements do not differ significantly among the three systems. Weight varies from 5249 lb for System C to 5677 lb for System B.

System A is the most cost-effective scheme, and System C is the most expensive. System C is still under development and is not yet available from the company. Modifications may reduce the system's price.

Cable units and auger anchors should not be included when purchasing Kelly Klosure structures to be built without guy wires. Instead, two flattened chord brackets and two 2 x 6 stiffback clamps should be purchased for every 4-ft length of building. Either System A or System B can then be used, depending on material availability. When System C becomes available, it should be reevaluated to confirm feasibility for TO applications.

Metric Conversion Factors

1 in.	=	25.4 mm
1 ft	=	0.3048 m
1 lb	=	0.453 kg
1 cu ft	=	0.028m ³
1 mph	=	1.609 kph

Table 1

**Material Costs for Galvanized Steel
and Fiberboard Panel Structures**

Building configuration	Panel insert	Base cost*
20 x 8 x 40 ft	Galvanized steel	\$5626.18
20 x 8 x 40 ft	Structural fiberboard	\$4672.35
20 x 12 x 40 ft	Galvanized steel	\$6341.13
20 x 12 x 40 ft	Structural fiberboard	\$5081.90

*The cost (August 1985) includes the 20 percent GSA discount to freight on board (F.O.B.) Fremont, NE, but excludes the cost of the 2- x 6-in. lumber used for the chords and baseplate.

Table 2

System Costs for 20- x 8- x 40-ft Structure

	Added cost	Total cost
System A	\$ 77.15	\$5818.53
System B	\$279.75	\$6039.13
System C	\$983.74	\$6725.12

Table 3

Logistics Requirements: System A

	Volume (cu ft)	Weight (lb)
Basic 20- x 8- x 40-ft structure	273.4	4871.0
Added:		
2 x 6 stiffbacks	9.2	320.0
2 x 4 knee braces and lateral brace	4.3	153.6
2 x 8 vs. 2 x 6 base plate	2.5	76.8
Flattened chord bracket	*	60.0
Stiffback clamps	*	11.2
Fasteners	*	17.0
Eliminated:		
24-in. cable unit	*	10.0
Auger anchors	*	21.2
<u>Net change</u>	<u>16.0</u>	<u>607.4</u>
Total	289.4	5478.4

*No significant change.

Table 4**Logistics Requirements: System B**

	Volume (cu ft)	Weight (lb)
Basic 20- x 8- x 40-ft structure	273.4	4871.0
Added:		
2 x 6 stiffbacks	9.2	320.0
2 x 4 lateral brace	1.5	51.2
2 x 8 vs. 2 x 6 base plate	2.5	76.8
1½ x 1½ x 1/8 steel angle	1.0	355.2
Flattened chord bracket	*	60.0
Fasteners	*	11.2
Eliminated:		
24-in. cable unit	*	10.0
Auger anchors	*	21.2
<u>Net change</u>	<u>14.2</u>	<u>853.2</u>
Total	287.6	5724.2

*No significant change.

Table 5**Logistics Requirements: System C**

	Volume (cu ft)	Weight (lb)
Basic 20- x 8- x 40-ft structure	273.4	4871.0
Added:		
Steel C-sections	21.8	592.0
Steel braces	*	92.0
2 x 12 vs. 2 x 6 base plate	7.2	288.0
Fasteners	*	5.0
Eliminated:		
2 x 6 chords	11.5	518.4
Chord brackets	*	60.0
24-in. cable unit	*	10.0
Auger anchors	*	21.2
<u>Net change</u>	<u>17.5</u>	<u>367.4</u>
Total	290.9	5238.4

*No significant change.

Table 6

Cost Estimate: System A

Cost of basic 20- x 8- x 40-ft structure	\$5741.38
Additional costs	
Lumber:	
2 x 4 knee braces, 80 ft @ .23	18.40
2 x 8 vs. 2 x 6 base plate, 120 ft @ .50 - .36	16.80
2 x 6 stiffbacks, 160 ft @ .36	57.60
2 x 4 lateral brace, 40 ft. @ .23	9.20
Kelly Klosure parts:	
Flattened chord brackets, 20 @ 4.28	85.60
Stiffback clamps, 20 @ 2.72	54.40
Miscellaneous:	
Framing anchors, 20 @ .18	3.60
Nails, 5 lb @ .39	1.95
3/8- x 3½-in. bolts, 40 @ .22	8.80
	<u>256.35</u>
Eliminated costs	
Kelly Klosure parts:	
24-in. cable unit, 8 @ 18.72	149.76
Auger anchors, 8 @ 3.68	29.44
	<u>178.20</u>
Total additional cost	<u>77.15</u>
Total cost	\$5818.53

Table 7

Cost Estimate: System B

Cost of basic 20- x 8- x 40-ft structure \$5741.38

Additional costs

Lumber:

2 x 8 vs. 2 x 6 base plate, 120 ft @ .50 - .36	16.80
2 x 6 stiffbacks, 160 ft @ .36	57.60
2 x 4 lateral brace, 40 ft. @ .23	9.20

Steel:

1½ x 1½ x 1/8 angle, 289 ft @ .839	242.40
------------------------------------	--------

Kelly Klosure parts:

Flattened chord brackets, 20 @ 4.28	85.60
Stiffback clamps, 20 @ 2.72	54.40

Miscellaneous:

Framing anchors, 20 @ .18	3.60
Nails 5 lb @ .39	1.95
3/8- x 1-in. bolts, 54 @ .10	5.40
	476.95

Eliminated costs

Kelly Klosure parts:

24-in. cable unit, 8 @ 18.72	149.76
Auger anchors, 8 @ 3.68	29.44
	179.20

Total additional cost 297.75

Total cost \$6039.13

Table 8
Cost Estimate: System C

Cost of basic 20- x 8- x 40- ft structure	\$5741.38
Additional costs	
Lumber:	
2 x 12 vs. 2 x 6 base plate, 120 ft @ 0.86 - 0.36	60.00
Kelly Klosure parts:	
Steel frame, 4 @ 315.14	1260.54
	<u>1320.54</u>
Eliminated costs	
Lumber:	
Chord members, 200 ft @ 0.36	72.00
Kelly Klosure parts:	
Chord brackets, 20 @ 4.28	85.60
24-in. cable unit, 8 @ 18.72	149.76
Auger anchors, 8 @ 3.68	29.44
	<u>366.80</u>
Total additional cost	<u>983.74</u>
Total cost	\$6725.12

Table 9
Test Results Summary
for 20- x 8- x 40-ft Structure

	System A	System B	System C
Time to construct (manhours)	39.3	41.3	42.3
Average 50-mph deflection (in.)	3.91	4.26	2.44
Weight (lb)	5478	5724	5238
Volume (cu ft)	289.4	287.6	290.9
Cost (\$)	5818.53	6039.13	6725.12

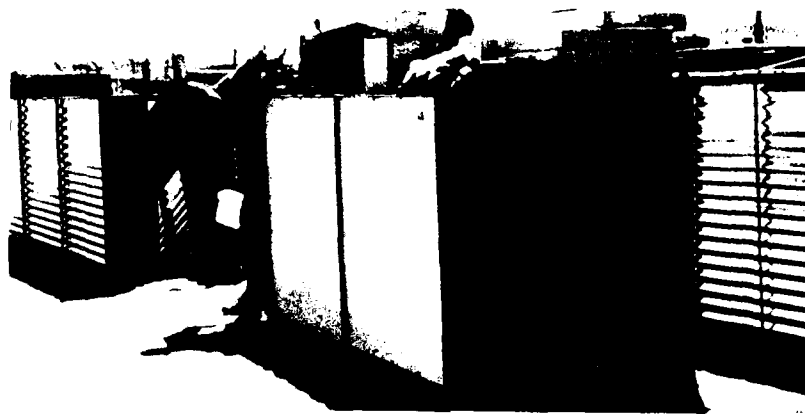

Figure 1. Panel racks.

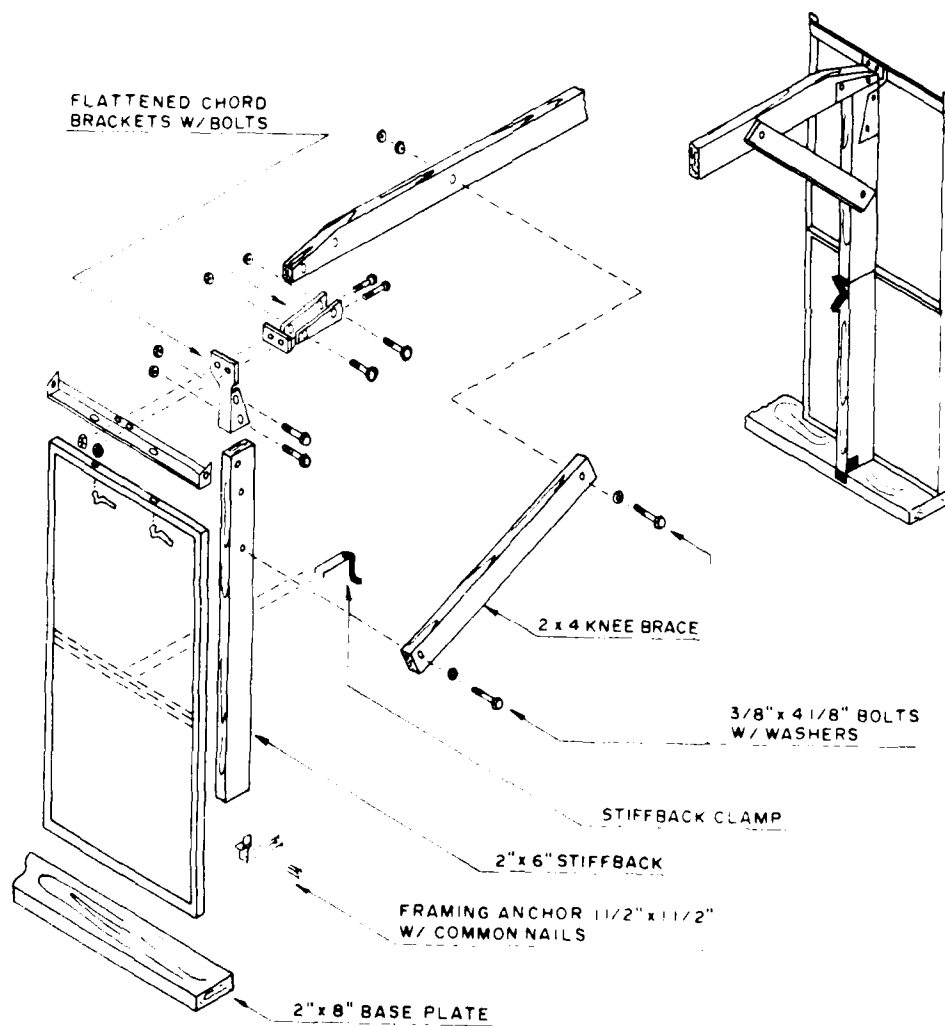

Figure 2. System A assembly.

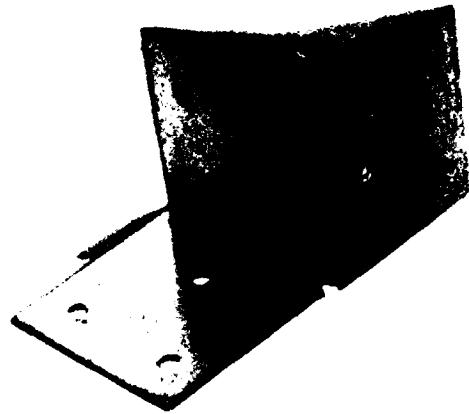

Figure 3. Framing anchor.

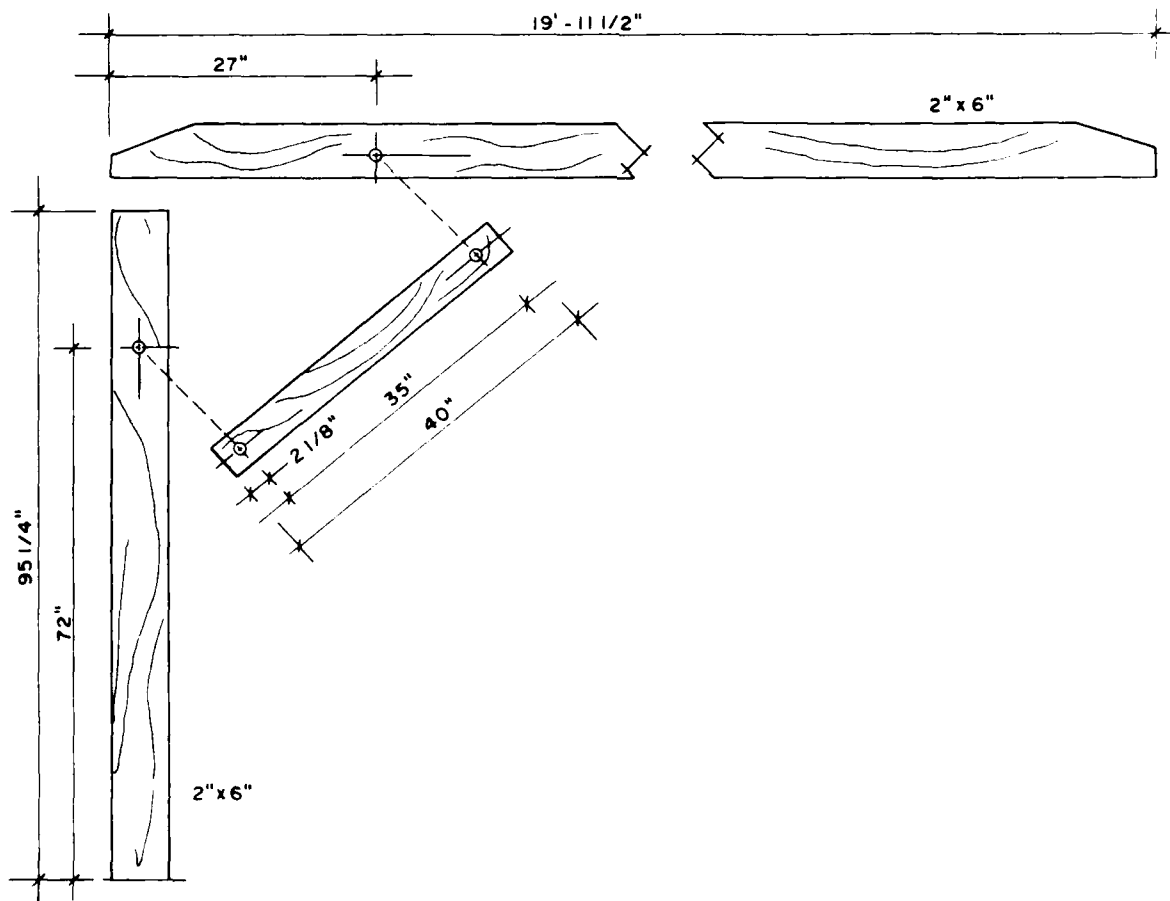

Figure 4. System A dimensions.

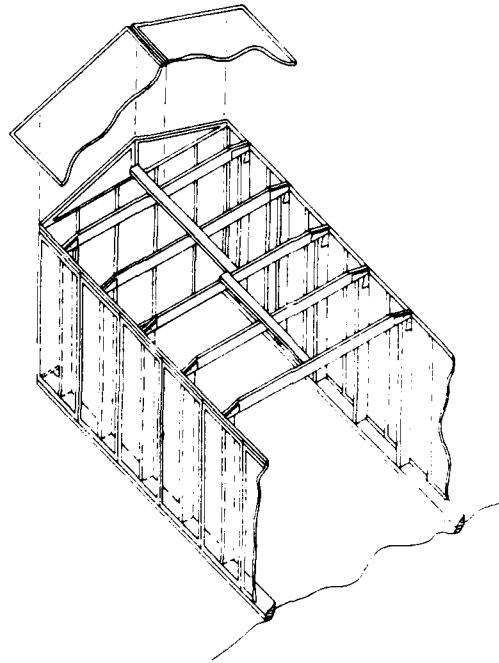

Figure 5. Lateral bracing of chords.

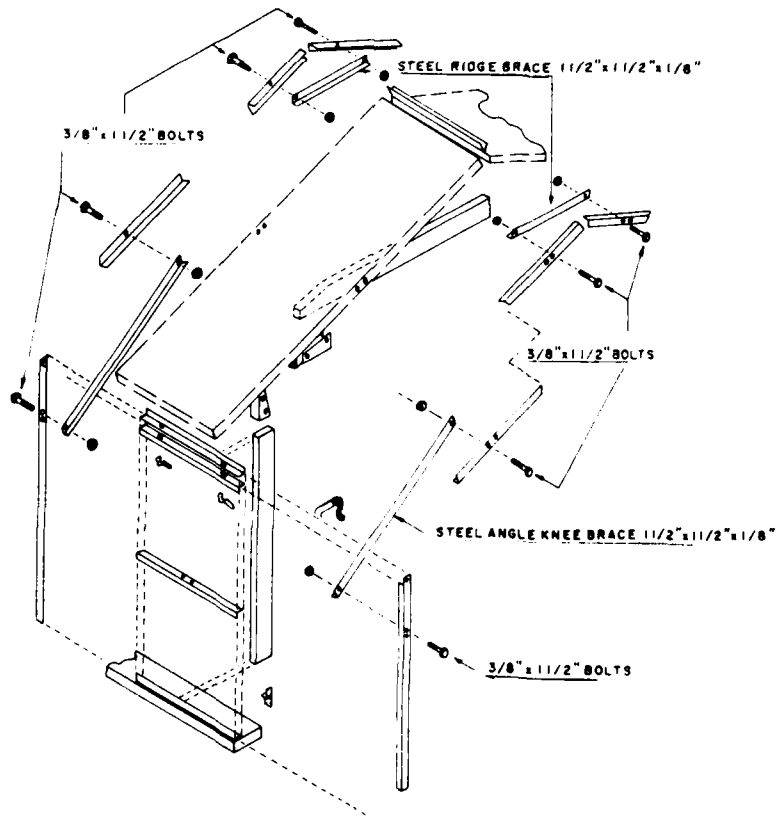

Figure 6. System B assembly.

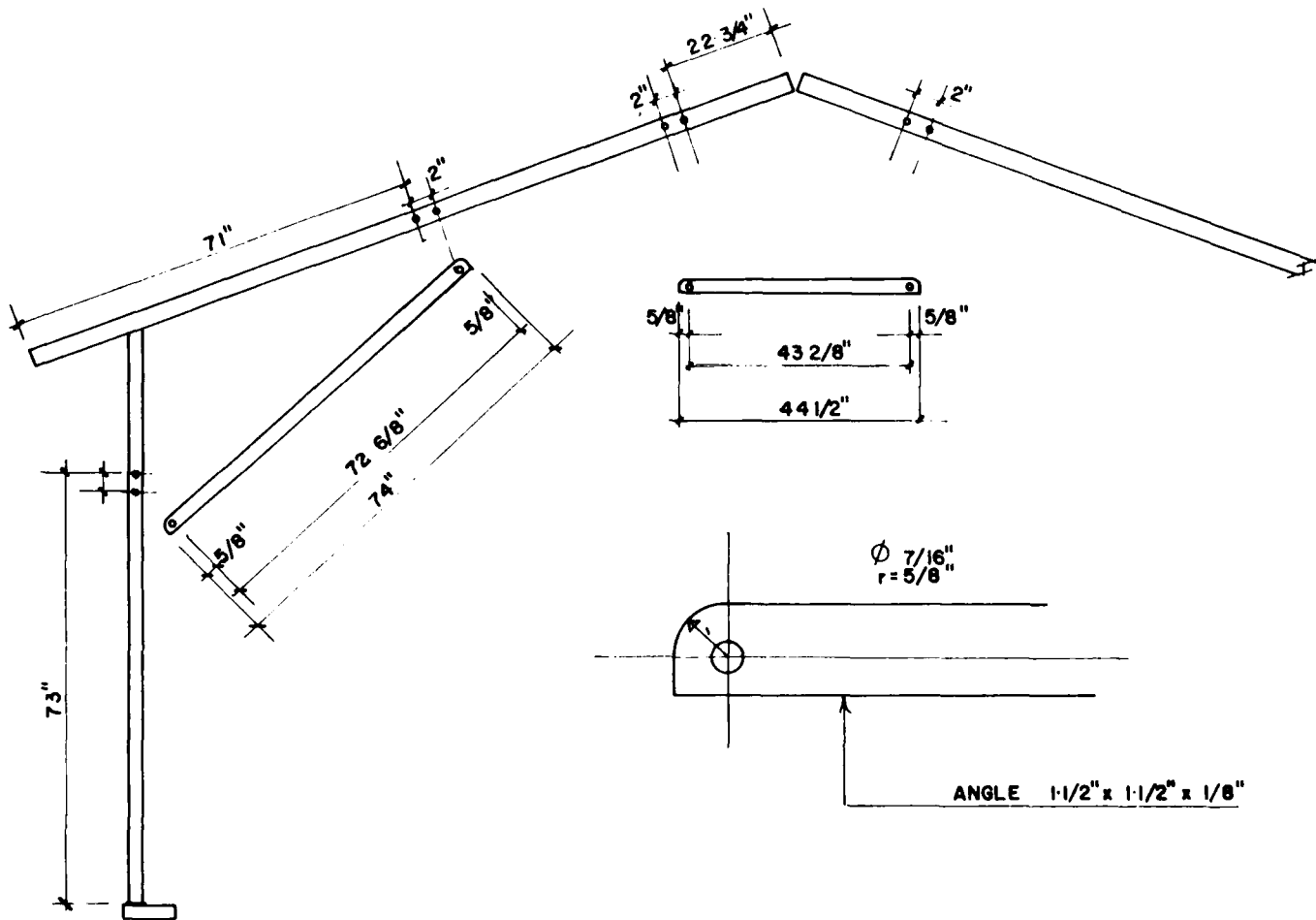

Figure 7. System B dimensions.

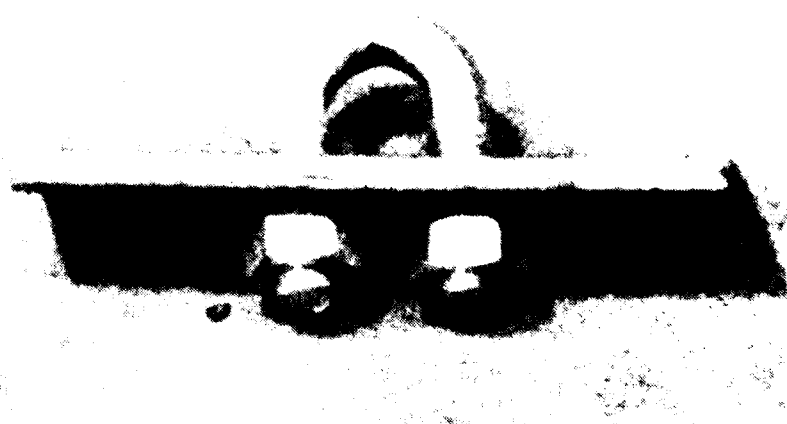

Figure 8. System C U-bolt connector.

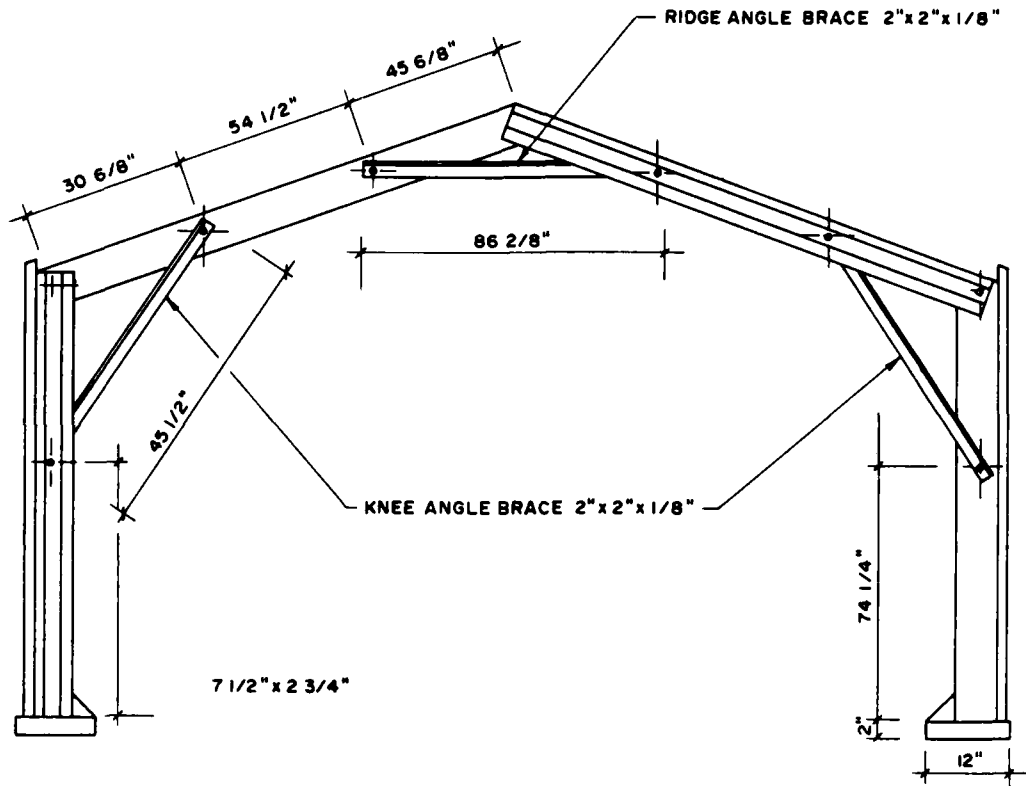

Figure 9. System C frame.



Figure 10. System C column base.

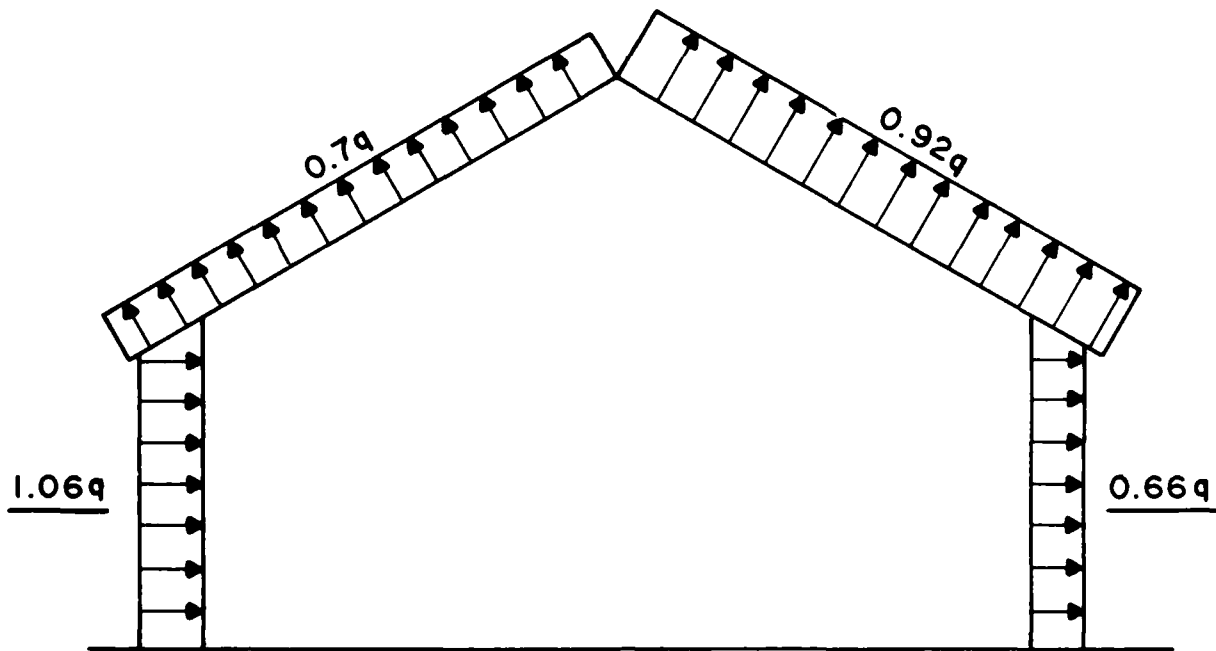

Figure 11. Average wind force coefficients, GC_p .

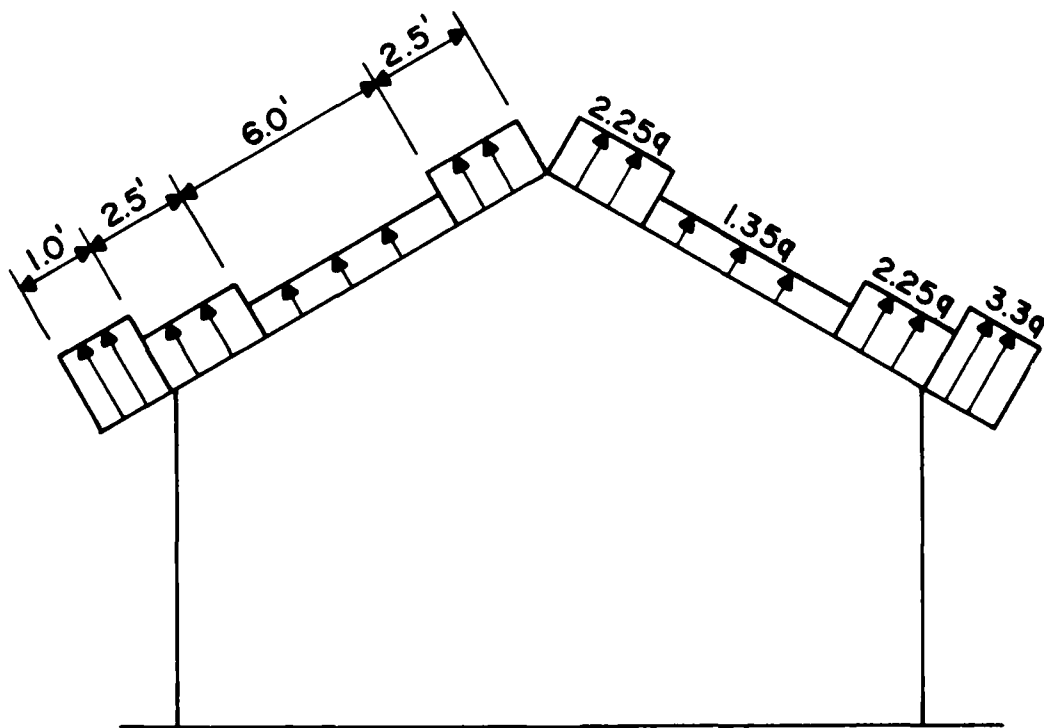

Figure 12. Locally severe wind force coefficients, GC_p .

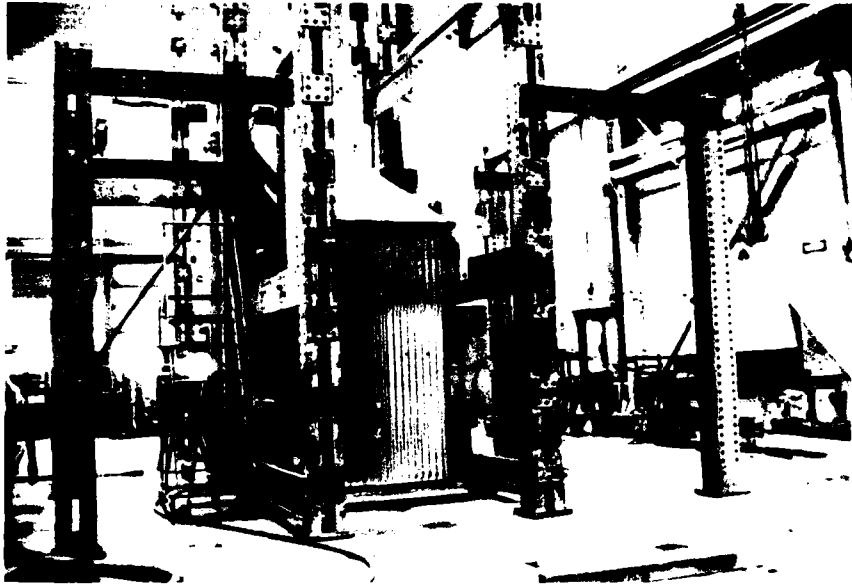

Figure 13. Load frame.



Figure 14. Roller plate in place.

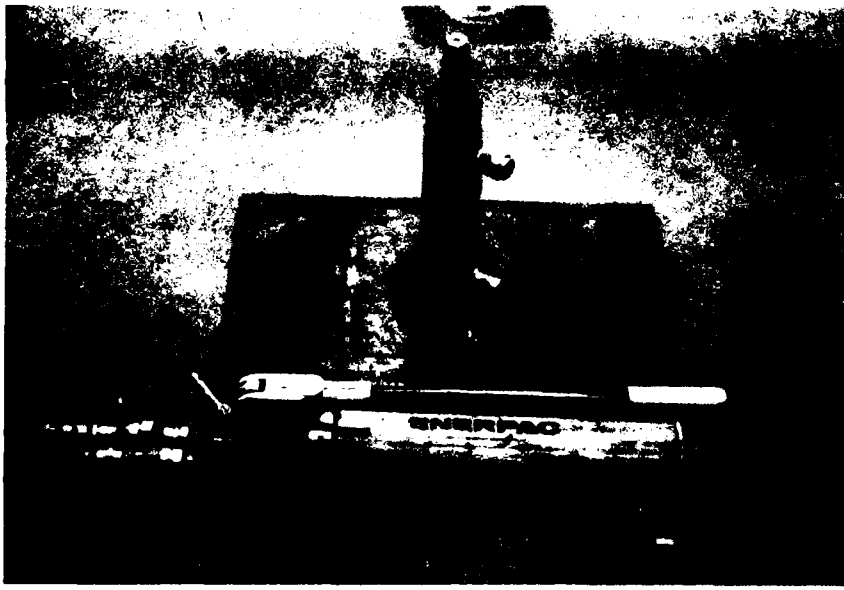

Figure 15. Hydraulic ram and pump.



Figure 16. Windward loading.



Figure 17. Leeward loading.



Figure 18. Equipment rack.

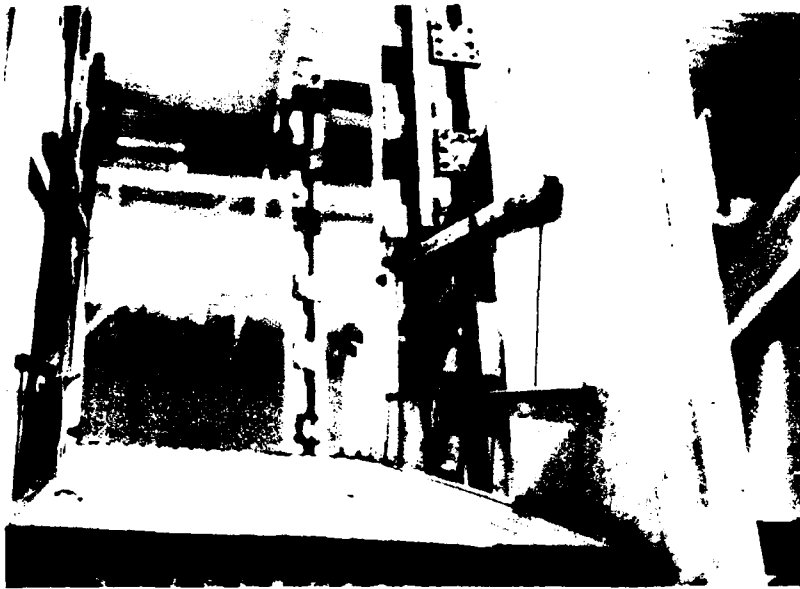

Figure 19. Uplift load scheme.

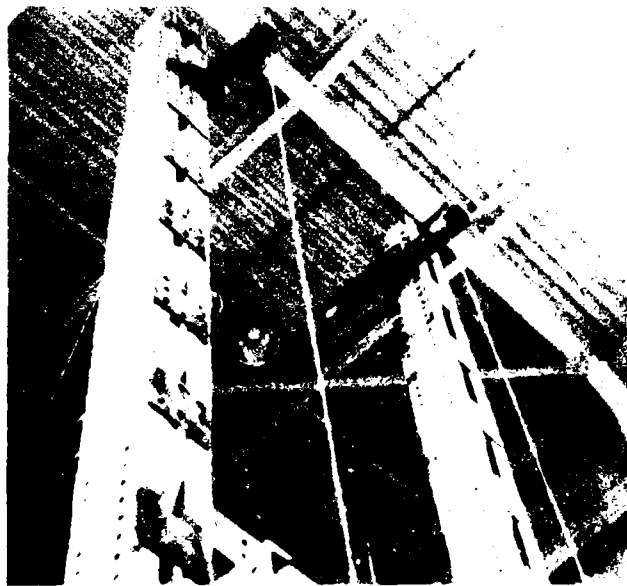

Figure 20. Pulley system.

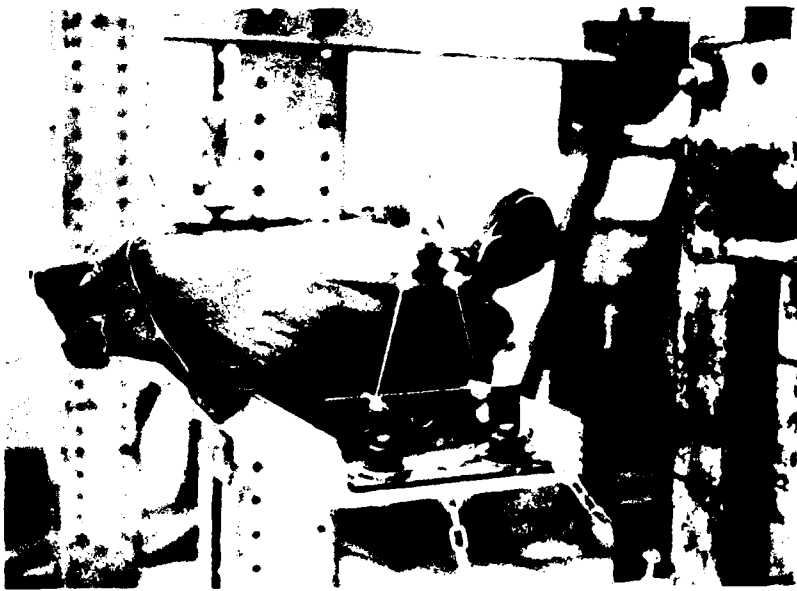

Figure 21. Sandbag loading.

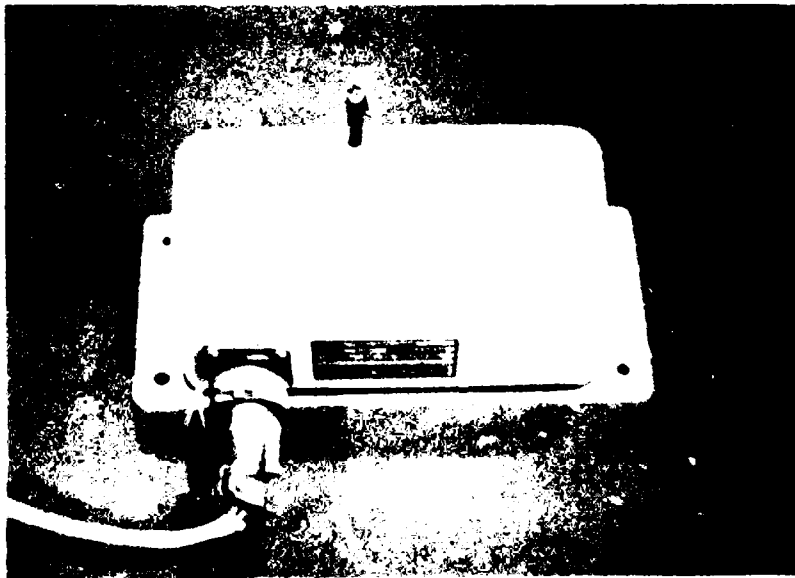
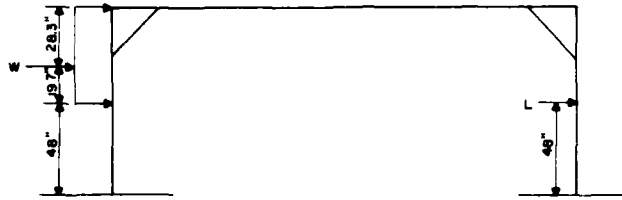
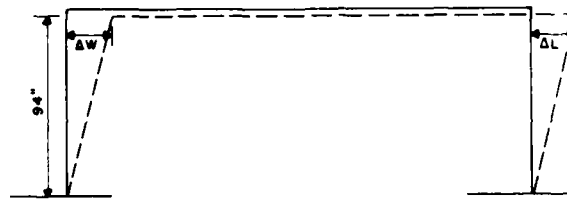

Figure 22. Position transducer.



TEST LOADING, SYSTEM A



DEFLECTIONS RECORDED, SYSTEM A

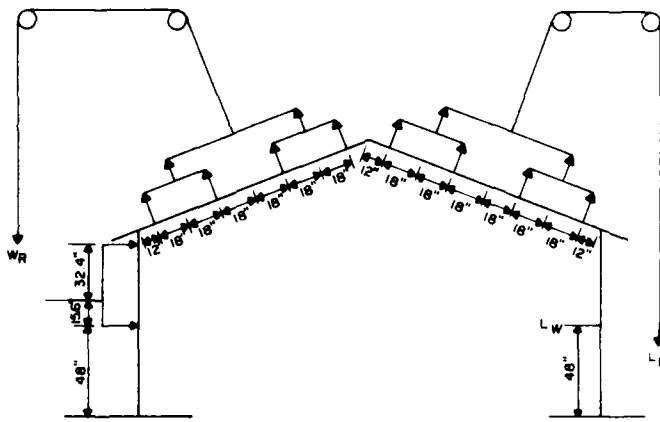

TEST LOADING, SYSTEMS B AND C

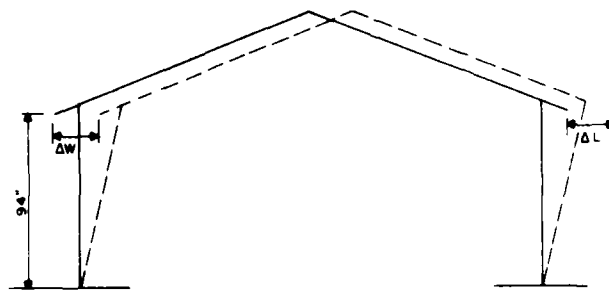

DEFLECTIONS RECORDED, SYSTEMS B AND C

Figure 23. Load application and deflection readings.

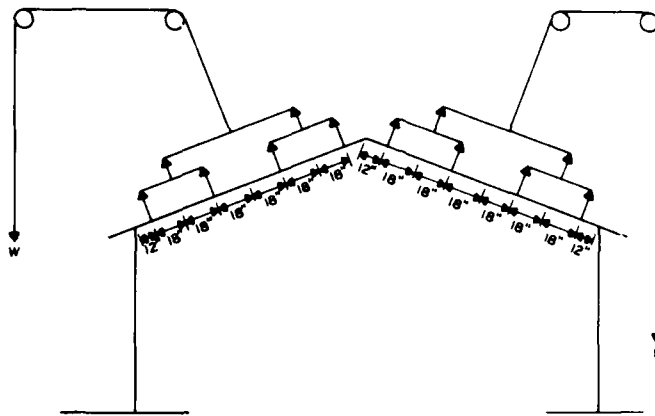

TEST LOADING, ROOF

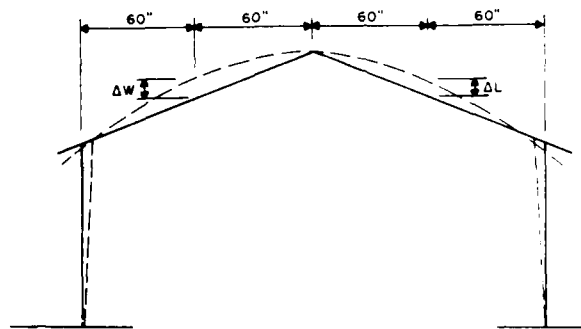

DEFLECTIONS RECORDED, ROOF TEST

Figure 23. (Cont'd)



Figure 24. Flattened chord bracket and stiffback.

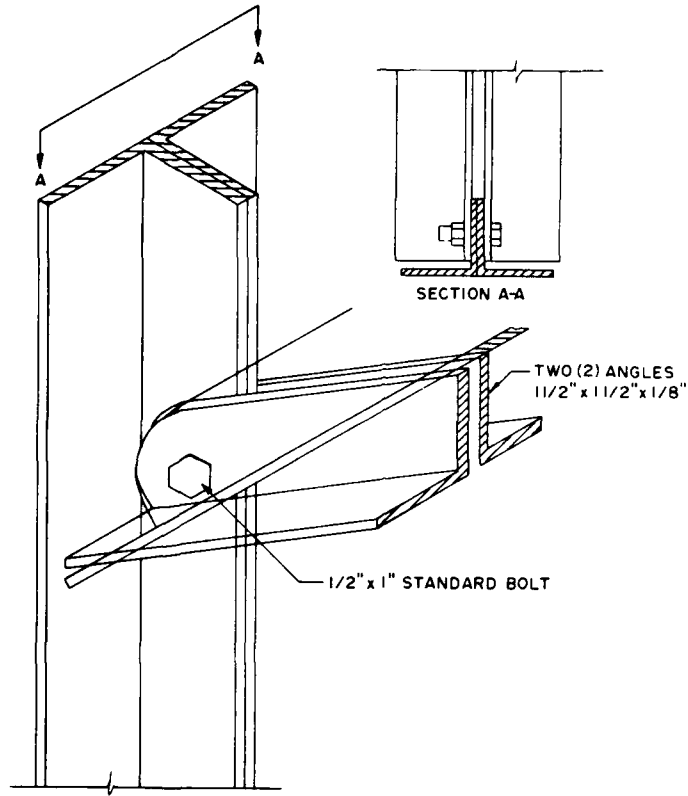

Figure 25. Double angle connection.



Figure 26. Column to rafter connection.

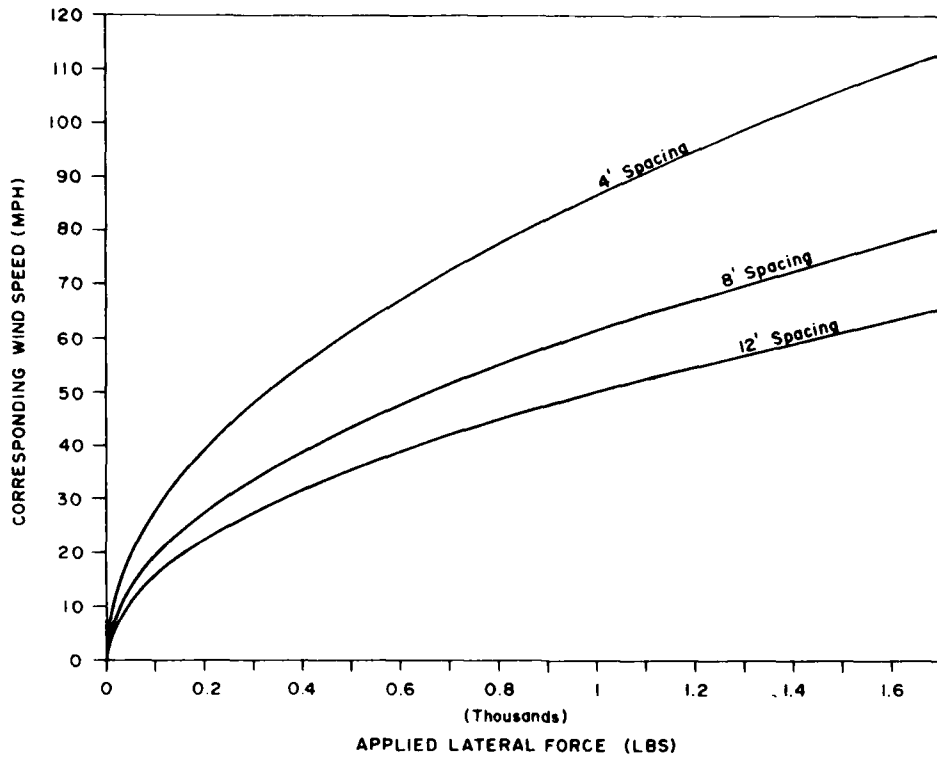

Figure 27. Wind speed vs. lateral force.

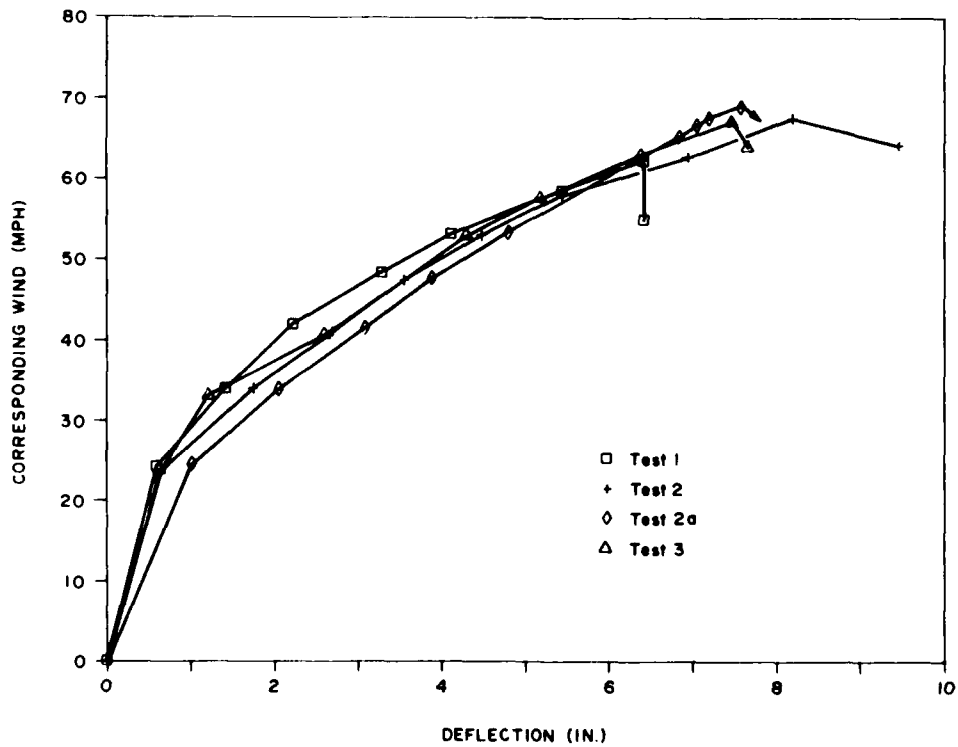

Figure 28. System A test results.



Figure 29. Test 1 failure.

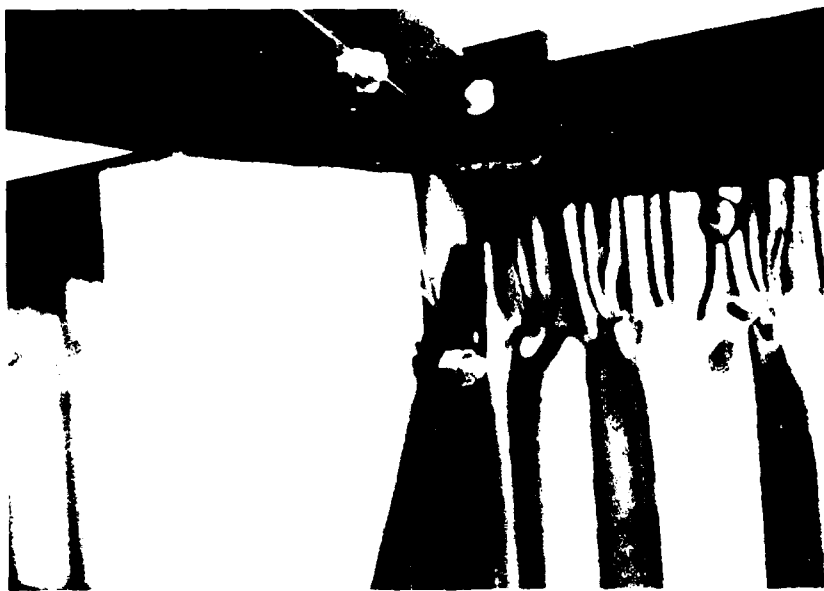

Figure 30. System A failure.



Figure 31. Leeward framing anchor failure.

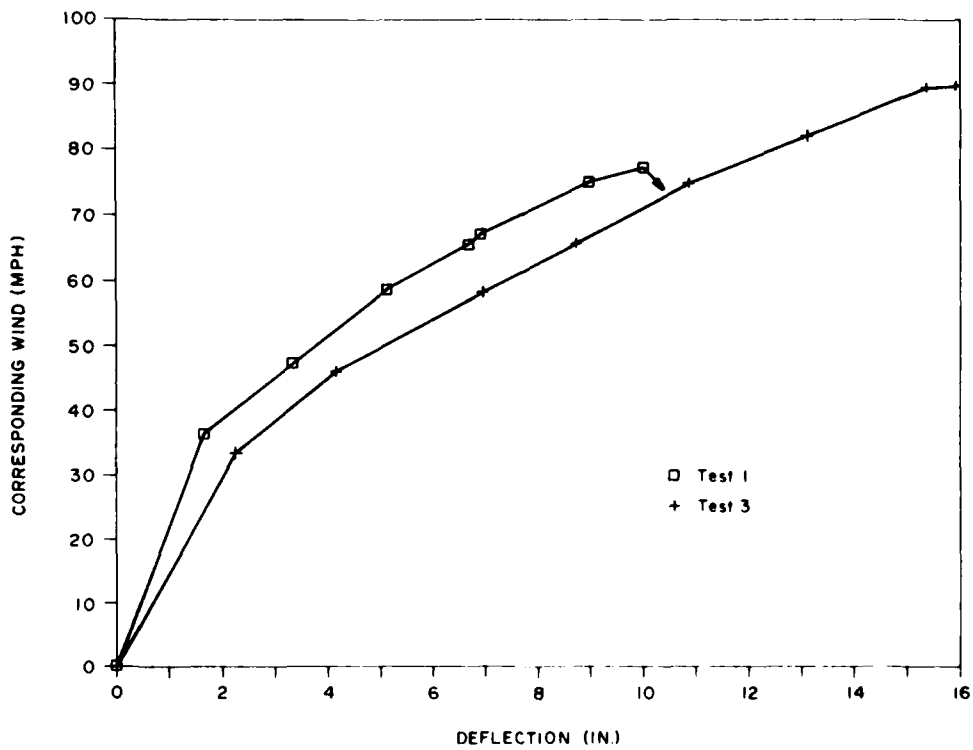

Figure 32. System B test results.

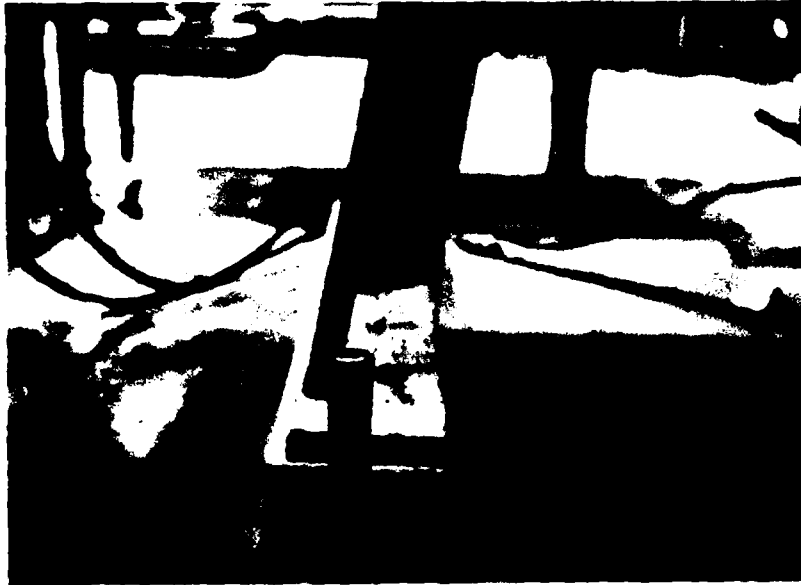

Figure 33. System B deflection.



Figure 34. System C failure.

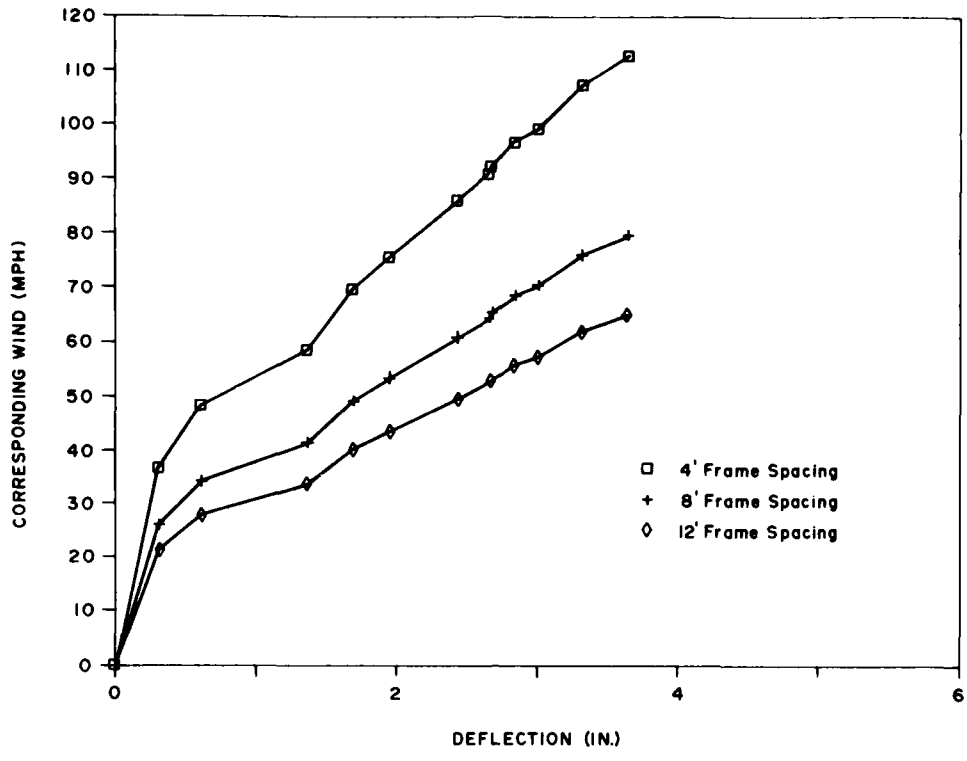

Figure 35. System C test results.

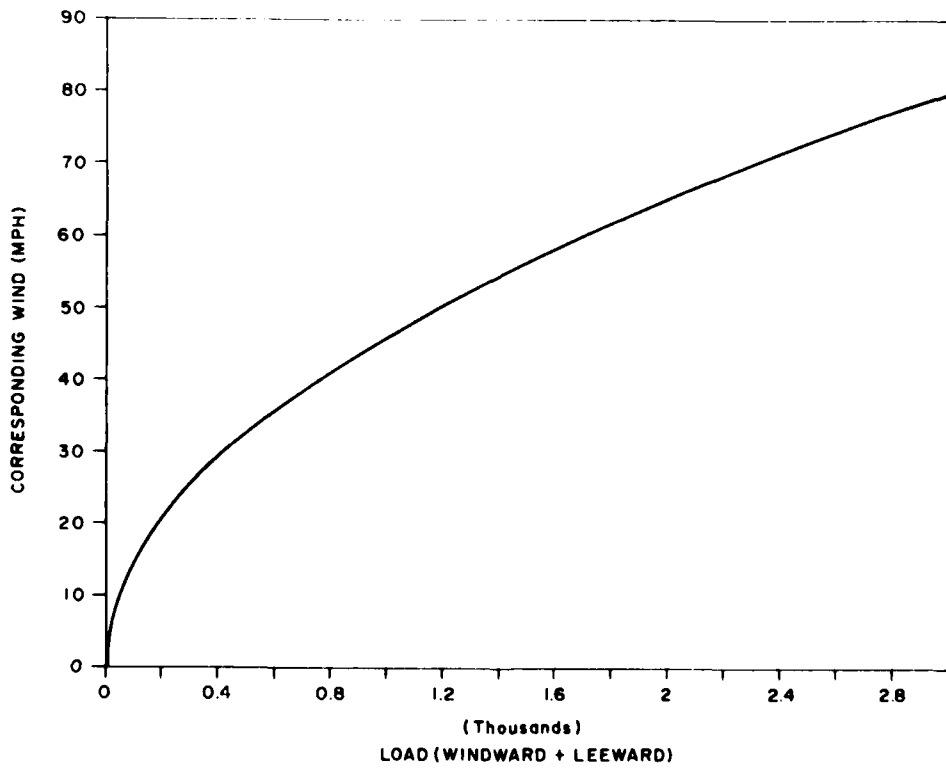

Figure 36. Total load vs. wind speed—roof test.

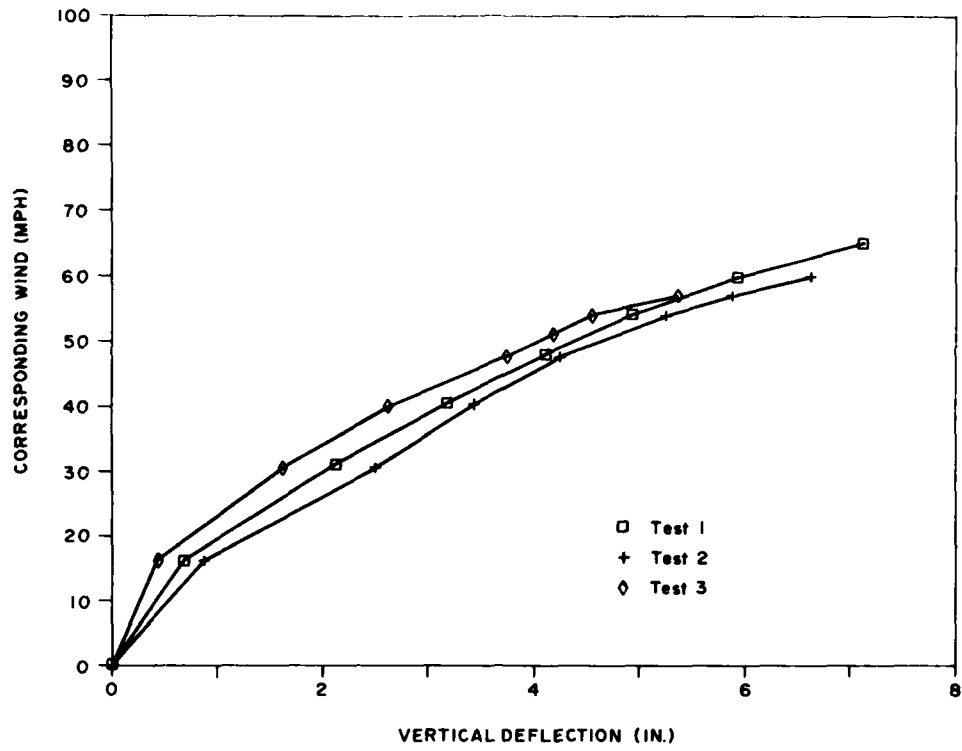

Figure 37. Roof test results.

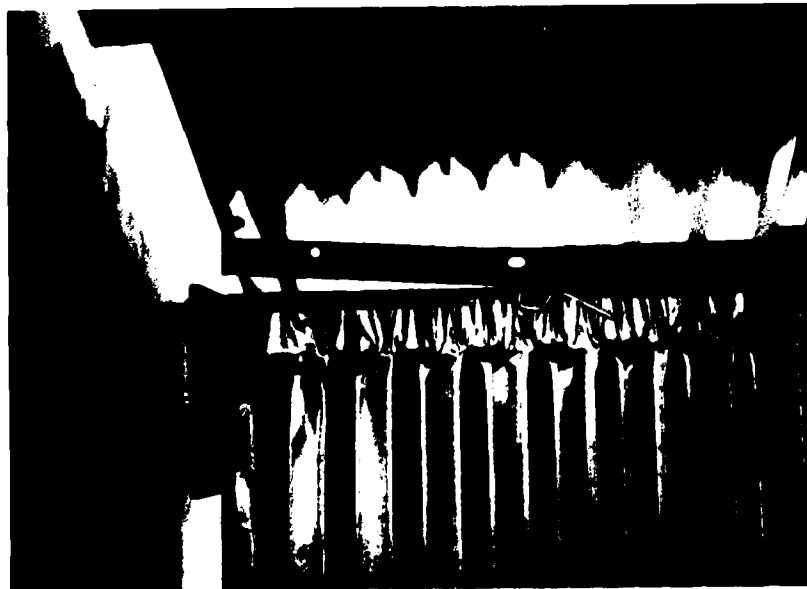

Figure 38. Roof test failure.

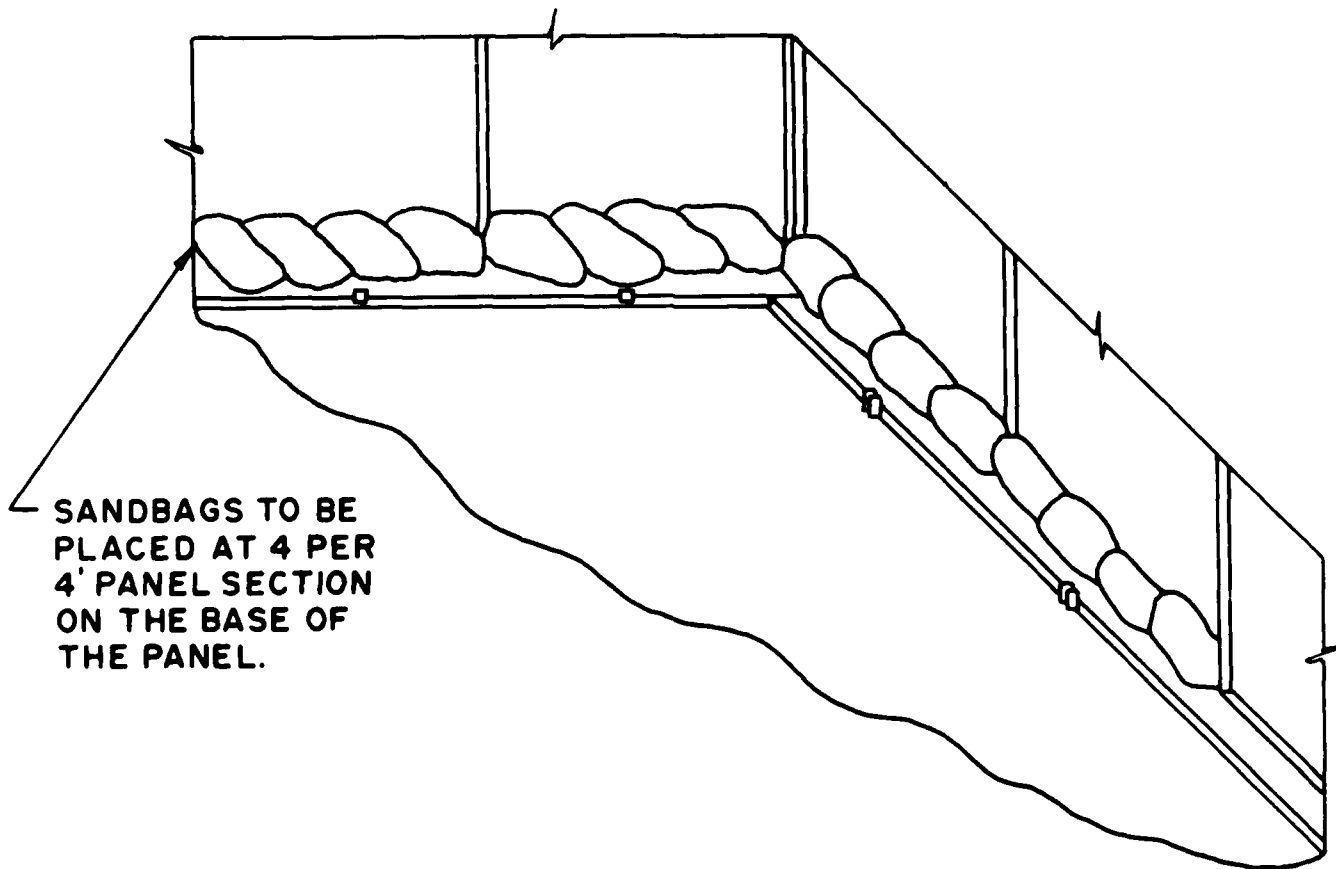

Figure 39. Sandbag foundation.

APPENDIX:

APPLIED LOADS AND WALL DEFLECTIONS

System A Test Results

Test 1

<u>Load (lb)</u>			<u>Corresponding wind (mph)</u>	<u>Deflections (in.)</u>		
<u>Windward wall</u>	<u>Leeward wall</u>	<u>Total load</u>		<u>Windward</u>	<u>Leeward</u>	<u>Average</u>
0.00	0.00	0.00	0.00	0.00	0.00	0.00
56.38	20.49	76.87	24.23	0.62	0.60	0.61
110.09	40.31	150.40	33.90	1.46	1.39	1.42
164.46	66.14	230.60	41.97	2.28	2.17	2.22
229.02	80.46	309.48	48.63	3.38	3.20	3.29
220.68	84.30	304.98	48.27	3.38	3.20	3.29
270.55	99.62	370.17	53.18	4.22	4.00	4.11
325.93	124.28	450.21	58.57	5.57	5.29	5.43
370.80	138.44	509.24	62.37	6.57	6.26	6.42
201.16	194.75	395.91	55.00	6.58	6.25	6.42

Test 2

<u>Load (lb)</u>			<u>Corresponding wind (mph)</u>	<u>Deflections (in.)</u>		
<u>Windward wall</u>	<u>Leeward wall</u>	<u>Total load</u>		<u>Windward</u>	<u>Leeward</u>	<u>Average</u>
0.00	0.00	0.00	0.00	0.00	0.00	0.00
56.04	19.16	75.20	23.97	0.67	0.64	0.66
112.59	39.65	152.24	34.10	2.04	1.46	1.75
165.29	53.98	219.27	40.93	2.97	2.34	2.65
217.17	79.30	296.47	47.59	3.88	3.20	3.54
270.71	99.13	369.84	53.16	4.82	4.11	4.47
327.26	115.46	442.72	58.16	5.77	5.04	5.41
379.30	137.78	517.09	62.85	7.29	6.56	6.93
435.68	164.10	599.78	67.69	8.52	7.80	8.16
367.29	175.77	543.06	64.41	9.81	9.07	9.44

Test 2a

Load (lb)			Corresponding wind (mph)	Deflections (in.)		
Windward wall	Leeward wall	Total load		Windward	Leeward	Average
0.00	0.00	0.00	0.00	0.00	0.00	0.00
53.88	25.15	79.03	24.57	1.05	1.00	1.03
106.09	44.31	150.40	33.90	2.12	2.03	2.08
160.80	65.64	226.44	41.59	3.14	3.03	3.09
216.84	82.63	299.47	47.83	3.94	3.83	3.89
263.38	109.95	373.33	53.41	4.91	4.71	4.81
324.76	127.78	452.54	58.80	5.69	5.47	5.58
379.47	140.44	519.91	63.02	6.49	6.24	6.37
447.70	112.12	559.82	65.40	6.97	6.69	6.83
439.69	146.61	586.30	66.93	7.17	6.89	7.03
448.53	153.77	602.30	67.83	7.33	7.04	7.19
496.23	131.28	627.51	69.24	7.73	7.73	7.58

Test 3

Load (lb)			Corresponding wind (mph)	Deflections (in.)		
Windward wall	Leeward wall	Total load		Windward	Leeward	Average
0.00	0.00	0.00	0.00	0.00	0.00	0.00
53.71	20.66	74.37	23.84	0.78	0.53	0.65
106.26	37.82	144.08	33.18	1.39	1.39	1.22
162.80	56.31	219.11	40.91	2.82	2.39	2.60
214.68	80.96	295.64	47.53	3.80	3.29	3.55
279.06	94.29	373.35	53.41	4.59	4.03	4.31
270.22	97.46	367.68	53.00	4.58	4.03	4.31
328.77	112.45	441.22	58.06	5.45	4.89	5.17
323.10	126.61	449.71	58.62	5.72	5.15	5.44
378.81	145.44	524.25	63.29	6.68	6.08	6.38
433.85	156.93	590.78	67.18	7.75	7.12	7.44
281.23	259.73	540.96	64.29	7.94	7.35	7.65

System B Test Results

Test 1

<u>Wall loads (lb)</u>		<u>Roof loads (lb)</u>		<u>Lateral load</u>	<u>Deflections (in.)</u>			<u>Corresponding wind (mph)</u>
<u>Windward</u>	<u>Leeward</u>	<u>Windward</u>	<u>Leeward</u>		<u>Windward</u>	<u>Leeward</u>	<u>Average</u>	
0.00	0.00	0.00	0.00	0.00	0.00	0.00	0.00	0.00
103.08	56.98	70.00	102.00	173.07	1.74	1.59	1.66	36.36
195.99	77.14	139.00	188.00	293.06	3.49	3.20	3.34	47.32
290.73	134.78	208.00	273.00	451.45	5.34	4.90	5.12	58.73
369.80	161.10	279.00	363.00	565.06	7.02	6.37	6.69	65.70
393.81	162.10	279.00	363.00	590.07	7.23	6.57	6.90	67.14
488.72	202.25	351.00	462.00	736.11	9.46	8.50	8.98	74.99
563.12	168.77	420.00	545.00	782.73	10.60	9.43	10.01	77.33

Test 2

<u>Wall loads (lb)</u>		<u>Roof loads (lb)</u>		<u>Lateral load</u>	<u>Deflections (in.)</u>			<u>Corresponding wind (mph)</u>
<u>Windward</u>	<u>Leeward</u>	<u>Windward</u>	<u>Leeward</u>		<u>Windward</u>	<u>Leeward</u>	<u>Average</u>	
0.00	0.00	0.00	0.00	0.00	ND	ND	ND	0.00
94.74	47.81	70.00	90.00	150.68	--	--	--	33.93
197.49	69.97	139.00	192.00	289.02	--	--	--	46.99
300.57	147.61	208.00	275.00	475.43	--	--	--	60.27
396.48	132.61	277.00	374.00	568.54	--	--	--	65.91
499.40	218.08	348.00	459.00	762.62	--	--	--	76.33
588.30	265.73	420.00	545.00	904.87	--	--	--	83.15
423.00	255.90	473.00	629.00	742.35	--	--	--	75.31

Test 3

<u>Wall Loads (lb)</u>		<u>Roof loads (lb)</u>		<u>Lateral load</u>	<u>Deflections (in.)</u>			<u>Corresponding wind (mph)</u>
<u>Windward</u>	<u>Leeward</u>	<u>Windward</u>	<u>Leeward</u>		<u>Windward</u>	<u>Leeward</u>	<u>Average</u>	
0.00	0.00	0.00	0.00	0.00	0.00	0.00	0.00	0.00
99.58	33.99	70.00	102.00	146.58	2.33	2.18	2.26	33.46
194.82	64.64	139.00	185.00	278.17	4.25	4.04	4.15	46.10
297.74	121.12	210.00	275.00	445.30	7.11	6.78	6.95	58.33
384.97	141.61	279.00	374.00	565.22	8.98	8.44	8.71	65.71
489.06	200.92	351.00	460.00	734.31	11.24	10.46	10.85	74.90
599.31	231.74	420.00	545.00	881.89	13.65	12.54	13.10	82.08
694.72	292.88	473.00	629.00	1051.05	16.02	14.66	15.34	89.61
687.38	302.55	546.00	710.00	1056.63	16.63	15.13	15.88	89.85

System C Test Results

Test 1

	<u>Wall loads (lb)</u>		<u>Roof loads (lb)</u>		<u>Lateral load</u>	<u>Deflections (in.)</u>			<u>Corresponding wind (mph)</u>		
	<u>Windward</u>	<u>Leeward</u>	<u>Windward</u>	<u>Leeward</u>		<u>Windward</u>	<u>Leeward</u>	<u>Average</u>	<u>4-ft spacing</u>	<u>8-ft spacing</u>	<u>12-ft spacing</u>
	0.00	0.00	0.00	0.00	0.00	0.00	0.00	0.00	0.00	0.00	0.00
	105.08	63.64	72.00	90.00	176.04	0.30	0.32	0.31	36.67	25.93	21.17
	193.99	98.13	143.00	176.00	305.54	0.64	0.58	0.61	48.31	34.16	27.89
	289.73	132.61	212.00	275.00	447.96	1.44	1.29	1.36	58.50	41.37	33.78
	406.49	198.59	285.00	360.00	635.58	1.78	1.60	1.69	69.68	49.27	40.23
	495.73	216.08	354.00	443.00	748.01	2.07	1.83	1.95	75.60	53.45	43.65
	607.49	322.20	430.00	527.00	969.14	2.57	2.30	2.44	86.05	60.85	49.68
	732.59	311.88	504.00	608.00	1086.77	2.87	2.46	2.67	91.12	64.43	52.61
	804.98	269.23	504.00	608.00	1116.51	2.90	2.45	2.68	92.36	65.31	53.32
	838.17	316.54	504.00	690.00	1230.36	3.07	2.61	2.84	96.95	68.56	55.98
	900.72	313.54	579.00	775.00	1293.97	3.25	2.76	3.00	99.43	70.31	57.40
	989.12	441.49	654.00	856.00	1512.76	3.57	3.07	3.32	107.51	76.02	62.07
	1082.03	482.47	783.00	1019.00	1660.48	3.93	3.37	3.65	112.63	79.64	65.03

Roof Test Results

Test 1

Roof load (lb)		Deflection (in.)		Corresponding wind (mph)
Windward	Leeward	Windward	Leeward	
0.00	0.00	0.00	0.00	0.00
53.00	69.00	0.75	0.63	16.22
229.00	222.00	2.13	2.13	31.19
382.00	382.00	3.00	3.38	40.60
531.00	541.00	4.00	4.25	48.09
681.00	685.00	4.88	5.00	54.28
831.00	833.00	5.75	6.13	59.91
983.00	984.00	6.88	7.38	65.14

Test 2

Roof load (lb)		Deflection (in.)		Corresponding wind (mph)
Windward	Leeward	Windward	Leeward	
0.00	0.00	0.00	0.00	0.00
53.00	69.00	0.88	0.88	16.22
216.00	218.00	2.50	2.50	30.60
383.00	373.00	3.50	3.38	40.38
532.00	523.00	4.25	4.25	47.71
681.00	674.00	5.25	5.25	54.07
755.00	759.00	5.88	5.88	57.15
831.00	842.00	6.63	6.63	60.08

Test 3

Roof load (lb)		Deflection (in.)		Corresponding wind (mph)
Windward	Leeward	Windward	Leeward	
0.00	0.00	0.00	0.00	0.00
53.00	69.00	0.38	0.50	16.22
206.00	229.00	1.63	1.63	30.63
369.00	373.00	2.63	2.63	40.01
531.00	523.00	3.88	3.63	47.68
607.00	608.00	4.25	4.13	51.20
681.00	684.00	4.63	4.50	54.26
755.00	761.00	5.25	5.50	57.19

USA-CERL DISTRIBUTION

Chief of Engineers
 ATTN: Tech Monitor
 ATTN: DAEN-IMS-L (2)
 ATTN: DAEN-CCP
 ATTN: DAEN-CW
 ATTN: DAEN-CWE
 ATTN: DAEN-CWM-R
 ATTN: DAEN-CWO
 ATTN: DAEN-CWP
 ATTN: DAEN-EC
 ATTN: DAEN-ECC
 ATTN: DAEN-ECE
 ATTN: DAEN-ECR
 ATTN: DAEN-RD
 ATTN: DAEN-RDC
 ATTN: DAEN-RDM
 ATTN: DAEN-RM
 ATTN: DAEN-ZCE
 ATTN: DAEN-ZCP
 ATTN: DAEN-ZCI
 ATTN: DAEN-ZCM
 ATTN: DAEN-ZCZ

FESA, ATTN: Library 22060
 ATTN: DET III 79906

US Army Engineer Districts
 ATTN: Library (41)

US Army Engineer Divisions
 ATTN: Library (14)

US Army Europe
 AEAE-ODCS/Engr 09403
 ISAE 09081
 V Corps
 ATTN: DEH (11)
 VII Corps
 ATTN: DEH (15)
 21st Support Command
 ATTN: DEH (12)
 USA Berlin
 ATTN: DEH (11)
 USASETAP
 ATTN: DEH (10)
 Allied Command Europe (ACE)
 ATTN: DEH (3)

8th USA, Korea (19)

USA Japan (USARJ)
 ATTN: AJEN-DEH 96343
 ATTN: DEH-Honshu 96343
 ATTN: DEH-Okinawa 96331

416th Engineer Command 60623
 ATTN: Facilities Engineer

US Military Academy 10966
 ATTN: Facilities Engineer
 ATTN: Dept of Geography &
 Computer Science
 ATTN: DSCPER/MAEN-A

AMMRC, ATTN DRXMR-WE 02172

USA ARRCOM 61299
 ATTN: DRCIS-RI-I
 ATTN: DRSAR-IS

AMC - Dir., Inst., & Servc
 ATTN: DEH (23)

DLA ATTN: DLA-WI 22314

DNA ATTN: NADS 20305

FORSCOM
 FORSCOM Engr, ATTN: AFEN-DEH
 ATTN: DEH (23)

HSC
 ATTN: HSLO-F 78234
 ATTN: Facilities Engineer
 Fitzsimons AMC 80240
 Walter Reed AMC 20012

INSCOM - Ch, Instl. Div
 ATTN: Facilities Engineer (3)

ROK/US Combined Forces Command 96301
 ATTN: EUSA-HHC-CFC/Engr
 MDW, ATTN: DEH (3)

MTMC
 ATTN: MTMC-SA 20315
 ATTN: Facilities Engineer (3)

NARADCOM, ATTN: DRDNA-F 01760

TARCOM, Fac. Div. 48090

TRADOC
 HQ, TRADOC, ATTN: ATEN-DEH
 ATTN: DEH (19)

TSARCOM, ATTN: STSAS-F 63120

USACC, ATTN: Facilities Engr (2)

WESTCOM
 ATTN: DEH, Ft. Shafter 96858
 ATTN: APEN-IM

SHAPE 09055
 ATTN: Surv. Section, CCB-OPS
 Infrastructure Branch, LANDA

HQ USEUCOM 09128
 ATTN: ECJ 4/7-LOE

PORT BELVOIR, VA 22060 (7)
 ATTN: Canadian Liaison Officer
 ATTN: British Liaison Officer
 ATTN: Australian Liaison Officer
 ATTN: French Liaison Officer
 ATTN: German Liaison Officer
 ATTN: Water Resources Support Ctr
 ATTN: Engr Studies Center
 ATTN: Engr Topographic Lab.
 ATTN: ATZA-DTE-SU
 ATTN: ATZA-DTE-EM
 ATTN: R&D Command

CRREL, ATTN: Library 03755

WES, ATTN: Library 39180

HQ, XVIII Airborne Corps
 and Fort Bragg
 ATTN: APZA-FE-EE 28307

Area Engineer, AEDC-Area Office
 Arnold Air Force Station, TN 37389

Chanute AFB, IL 61868
 3345 CES/DE, Stop 27

Norton AFB, CA 92409
 ATTN: APRCE-MX/DEE

AFESC, Tyndall AFB, FL 32403

NAVFAC
 ATTN: Engineering Command (7)
 ATTN: Division Offices (6)
 ATTN: Naval Public Works Center (9)
 ATTN: Naval Civil Engr Lab. (3)

ATTN: Library, Code LOBA NCEL 93043

Defense Technical Info. Center 22314
 ATTN: DDA (2)

Engr Societies Library, NY 10017

Natl Guard Bureau Instl. Div 20310

US Govt Print Office 22304
 Receiving Sect/Depository Copies (2)

US Army Env. Hygiene Agency
 ATTN: HSHB-E 21010

National Bureau of Standards 20899

END

12-86

DTIC