

AD-A173 494

EVALUATION OF INTERCONNECTION TOPOLOGIES BY DISTRIBUTED 1/1  
COMPUTER MODELLING. (U) POLYTECHNIC OF CENTRAL LONDON  
(ENGLAND) Y PAKER FEB 83 DA-ERO-78-G-110

UNCLASSIFIED

F/G 17/2

ML

END

DATE

FILED

1986

FT.

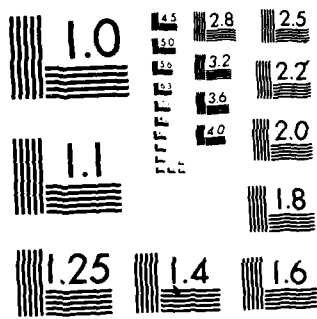

MICROCOPY RESOLUTION TEST CHART  
NATIONAL BUREAU OF STANDARDS-1963-A

UH/15399(5)



EVALUATION OF INTERCONNECTION TOPOLOGIES BY  
DISTRIBUTED COMPUTER MODELLING PACKAGE - MICROSS

1019186

AD-A173 494

Second Year  
Final Technical Report

by

Yakup PAKER

February 1983

European Research Office  
United States Army  
London W1, England  
Grant Number: DA-ERO-78-G-110

The Polytechnic of Central London

DTIC  
ELE  
OCT 24 1986  
A

DTIC FILE COPY

APPROVED FOR PUBLIC RELEASE  
DISTRIBUTION UNLIMITED

26 10 16 395

## **DISCLAIMER NOTICE**

**THIS DOCUMENT IS 'BEST QUALITY PRACTICABLE. THE COPY FURNISHED TO DTIC CONTAINED A SIGNIFICANT NUMBER OF PAGES WHICH DO NOT REPRODUCE LEGIBLY.**

EVALUATION OF INTERCONNECTION TOPOLOGIES BY DISTRIBUTED  
COMPUTER MODELLING PACKAGE - MICROSS

Y. Paker

| <u>Contents</u>                             | <u>Page</u> |
|---|-------------|
| 1. Introduction                             | 1           |
| 2. MICROSS system overview                  | 6           |
| 3. MICROSS system details                   | 12          |
| 4. Graphics facilities in MICROSS           | 34          |
| 5. Evaluation of interconnection topologies | 39          |
| References                                  | 49          |
| Appendix I                                  | 51          |

|                    |                                     |
|--------------------|-------------------------------------|
| Accession For      |                                     |
| NTIS GRA&I         | <input checked="" type="checkbox"/> |
| DTIC TAB           | <input type="checkbox"/>            |
| Unannounced        | <input type="checkbox"/>            |
| Justification      |                                     |
| By _____           |                                     |
| Distribution/      |                                     |
| Availability Codes |                                     |
| Dist               | Special                             |
| A-1                |                                     |



## 1. INTRODUCTION

This report reflects the work done during the second year of the three year project on "Control, Synchronization and Fault-Tolerant Operations in Variable Topology Multicomputer Systems". The first year has been reported in [1]. The overall purpose of the research work has been to investigate the architecture of a network of low cost computers (mini- or microcomputers) linked with serial communication paths which can be reconfigured according to the needs of each computation. This led to a novel architecture named Variable Topology Multicomputer, or VTM for short, developed by a previous three year US European Office Grant [2], [3].

The construction of parallel computer structures where relatively large numbers of computers, reaching two or three digit size has become feasible due to the advances in LSI technology which led to very low cost microprocessors, memories, and ancilliary circuits. Minicomputers have already introduced some degree of de-centralization in real time systems where it has become possible to place a computational resource nearer to the point where such a requirement exists. Such loosely linked computer networks are particularly attractive where the computational task is spatially distributed and has to be performed in real time. Microcomputers have accelerated this tendency to a greater extent by offering the designer remarkably flexible, powerful and low cost

components. Microelectronics industry has produced more powerful circuits such as 16-bit processors and 32-bit processors currently being introduced. On the high performance side, the US Defence Department project is an effort to achieve very high performance microprocessors [4]. Thus the technology limitations for a microcomputer as a point computing resource is yet to be reached. The availability of high performance yet low cost microprocessors is making the use of aggregates of such components as a tightly coupled structure more and more attractive. The software support available for more powerful microprocessors has also greatly improved; in addition to having high level language compilers e.g. Fortran and Pascal, sophisticated operating systems such as Unix are available for these machines. This provides a much richer environment for developing multi-microprocessor systems [5].

Another significant development has been the emergence of Local Area Networks (LAN's). These provide an interconnection medium for relatively large numbers of computers (mainly mini or micro). The contention bus scheme of Ethernet [6], the circulating token structure of the Cambridge Ring [7] and token passing ring [8] are some of the well known approaches. These are fixed topology architectures yet they offer fairly standardised interconnection media, very different from the store-forward scheme used for long-haul networks. However the standardisation is not being extended to the communication protocol level which goes beyond the link level protocols.

Many of the underlying control and synchronization problems are receiving greater attention, some due to LANs, others due to the greater use of distributed computing [9].

Distributed Operating Systems are of much interest as are the higher level language constructs for synchronisation and control, for example the rendezvous concept of the Ada language is designed to achieve synchronization between cooperating tasks.

These developments had fundamental implications in system design. Rather than sharing one powerful central machine, individual processes are identified and allocated to separate smaller machines for execution. Novel computer structures have emerged for implementing real time systems where the computational resources are distributed and interacting according to the requirements imposed by a particular application. Currently there exists an unprecedented range of components to be able to tailor a system such that computational power of required dosage is applied to points where data acquisition and processing functions are required. The current state of system technology, however, is not sufficiently developed to provide a designer with well integrated hardware, software and communication tools to build such networks as distributed computer systems. Given the complexity of many distributed computer systems, there exist very few design tools, if any, to understand and evaluate many of the options and performance under varying

operating conditions of the system prior to implementation and commissioning. Often, evaluation is done subsequent to installation as an afterthought, more for dealing with bottlenecks rather than to ensure that the system functions within well prescribed target specifications.

During 1979-81, a distributed computing simulation package called MICROSS was designed and developed by Dr. Bozyigit and myself, supported by a Science and Engineering Research Council research grant. The details of this package are introduced in this report. This system enables a designer to enter the specifications of a multi-processor system in terms of topology, transmission line and processor characteristics in an interactive manner. Following a simulation phase the reporting is done by plotting performance figures such as delay times, throughput, etc.. Thus MICROSS is a powerful package to evaluate various architectural approaches and topologies graphically in an interactive manner. MICROSS facilities are now offered as a service to various research groups and laboratories who would like to test the design options that they may have in distributed systems. MICROSS is seen as an important tool to evaluate a given architecture against a given application requirement.

In this report, Section 1 presents an introduction to the MICROSS modelling and simulation package. Sections 2 describes MICROSS in a more detailed manner, in particular the way a distributed computer system is specified for

modelling purposes. Section 4 introduces the graphical aids provided by MICROSS. Chapter 5 presents the outcome of a number of experiments carried out by H. English to evaluate the influence of interconnection topology on performance. This is done by taking two sets of network sizes: the first set contains 9 node configurations and the second set contains 16 node configurations. Clearly, facilities are here to study other network sizes and topologies. Section 6 is the conclusions.

## 2. MICROSS SYSTEM OVERVIEW

### 2.1 Modelling of Distributed Computer Systems

There have been numerous studies towards modelling DCS. The great majority, however, have been based on theoretical approaches which require mathematical understanding of the model in relation to the particular system under study. The designers of DCS, as well as those in other fields, are not necessarily in command of the mathematics involved. This gap can normally be filled by specialists who are able to formulate a particular model and present the results to the others involved. This technique, apart from the cost and the time factors involved, presents practical difficulties.

A considerable proportion of modelling studies is based on digital simulation techniques. Especially with high availability of computer power this has become a widespread practice. However, there is not any efficient formal approach despite the availability of some general purpose simulation languages or packets (GPSS, SIMULA, GASP, etc.). Here again, practice has been the development of dedicated simulation systems.

### 2.2 MICROSS approach of modelling of DCS

Development of MICROSS\* is based on an attempt to formalize

---

\* MICROSS' name was originally used as an abbreviation of multi-MICROprocessor based System Simulation

the interaction of basic components at functional level.

The use of MICROSS, it is hoped, will shorten the design cycle by reducing the modelling effort involved in the design of a distributed computer system. The foreseen advantages of MICROSS are as follows:

1. A designer can incorporate his system into MICROSS readily since the terminology used agrees with DCS terminology which he is also accustomed to.
2. MICROSS is interactive. The user is guided through the definition of his system components.
3. Interactive reporting facility provides easy examination and evaluation of a particular configuration.
4. Embedded standard networking alternatives i.e. protocols and routing provide alternative design options.
5. The graphics aid is provided at three levels. Definition of the system can be aided graphically. State of simulation can be graphically displayed at predetermined points in time using incremental simulation times. The graphical presentation of the results provides

for speedy decision making.

6. The adaptability of MICROSS regarding the computer installation, is high, the non-graphic MICROSS source package is coded in FORTRAN language which provides wide portability. The graphical MICROSS uses GINOF graphics package, a PLOT10 version will soon be implemented which will broaden the implementation area further.
7. In view of contemporary widespread implementation and use of distributed computer systems, geographically dispersed as well as local computer networks, MICROSS can be used as an educational tool to provide appreciation of DCS and give insight into their characteristics.

## 2.3 Functional components of a DCS

### 2.3.1 What is a function?

The definition of a function depends on the level with which the function is associated. For example, at one extreme a DCS consists of two main functional components, nodes which undertake application as well as switching tasks, and communication lines which have certain capacity of transmission. At the other extreme, there is circuit and/or instruction level of

functional decomposition which provides extensive details and many more options.

The highest level may be considered too crude, due to the availability of various alternative arrangements of a node made possible with the advances in LSI technology. The lowest level, on the other hand, contains too many redundant details which can easily distract the purpose of simulation, and may even make it unmanageable or impossible.

This study towards generalization of DCS modelling, has assumed an intermediate level where redundant details are excluded but enough means of control can be given to the designer over the hardware and software arrangements of each node involved in this system.

#### 2.3.2 MICROSS functional components and specification considerations

A node in a DCS consists of two main components (Figure 2.1):

1. Host side
2. Communication side as shown in Figure 2.1

The host side has functions associated to the application and communication side. The communication side, on the other hand, performs switching tasks which route messages towards their ultimate destination. Thus the hardware specifications that

# TWO NODES AS SIMULATED IN MICROSS

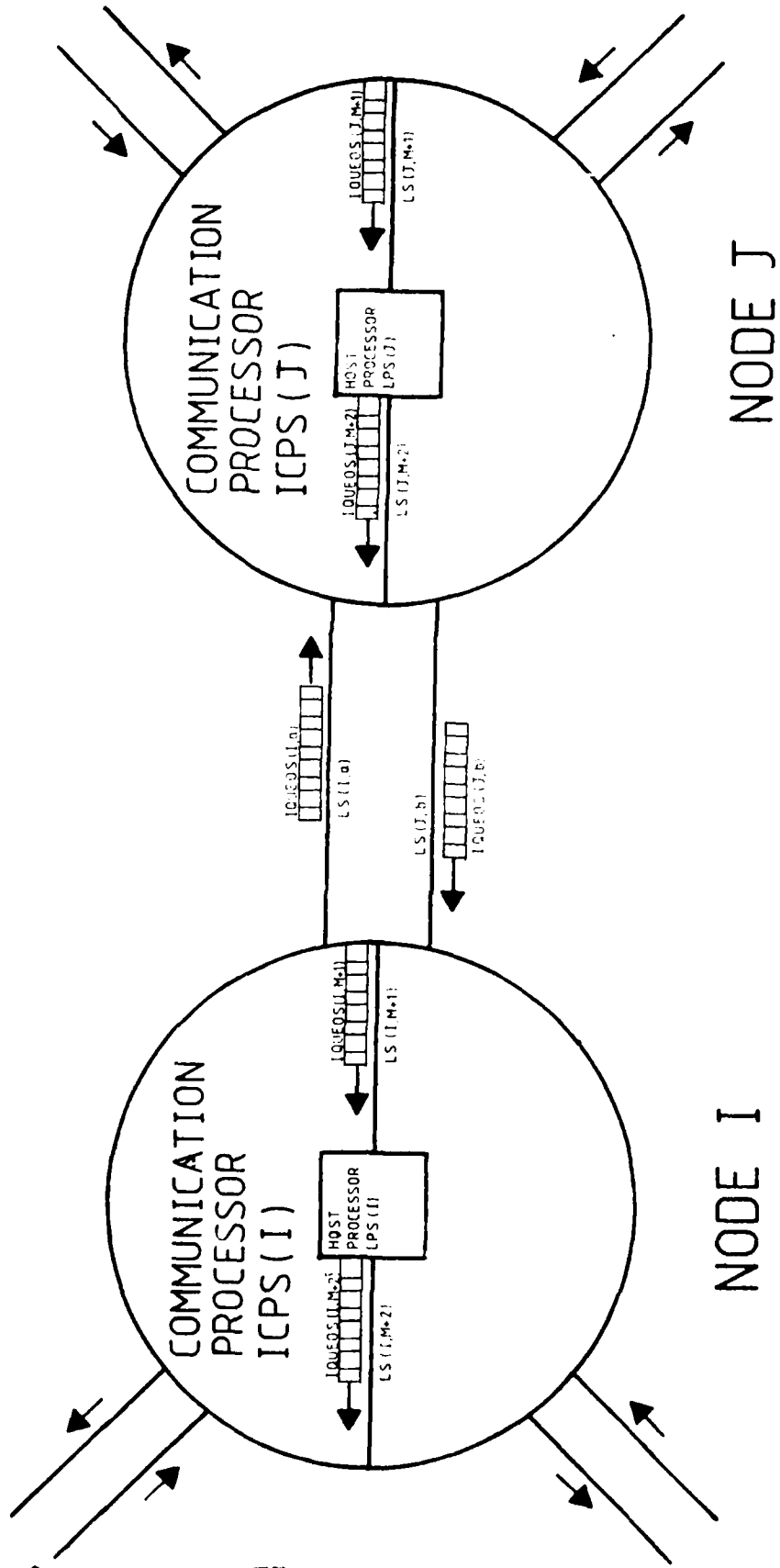

Figure 2.1 TWO NODES AS SIMULATED IN MICROSS

are related to the two components would be speed and memory with which the host and the communication node perform their functions. These speeds in MICROSS are given in kilo (1000) instructions per second. This relates to the size of software involved in carrying out specific tasks involved. The memory size is not a factor of high importance but it should be sufficient for the allocation of the software and the information in transit.

The local interface between the host and the local communication processors is specified by the protocol employed and the transmission speed of the interface circuitry. [The transmission media in the communication subsystem is often connected to the communication mechanism (or protocol) between the communication nodes.]

The interface transmission timing is modelled as

$$t = a + \ell / b$$

where  $a$  is a fixed value per unit information,  $b$  is a coefficient, and  $\ell$  is the number of units of data to be transmitted. The units depend on interpretation if, say,  $\ell$  is in bits and  $b$  is in mega bits per second, then  $a$  and  $t$  are in microseconds.

### 3. MICROSS system details

#### 3.1 Simulation technique

The simulation of DCS, obviously involves concurrent execution of various components on a single processor i.e. a mainframe computer environment. It is, therefore, important how the global time is advanced regarding discernible functional units such as host, communication processors, I/O ports, and communication links.

MICROSS employs an event based discrete simulation technique. This technique involves the ordering of the events, which are referred to as transaction (TX in short), in time and in precedence.

An event in the system can appear in one of the five states:

1. scheduled: waiting to take place
2. active: taking place
3. suspended (or blocked): waiting for the requested  
facility to become free
4. pre-empted: prevented by a higher priority TX
5. dormant: TX completes its life through the system  
and terminates for good.

Figure 3.1 shows the transition of TX states.

# STATES OF A TRANSACTION

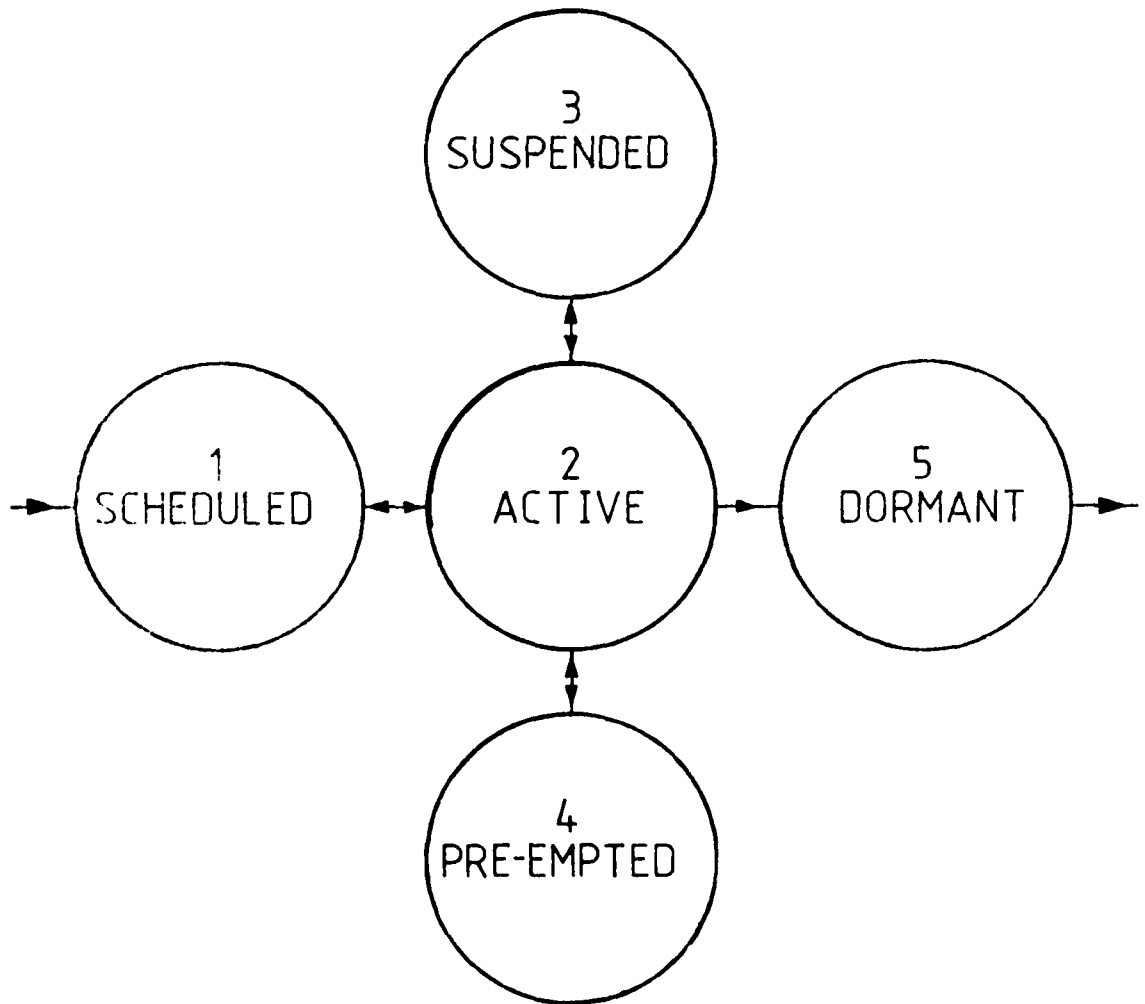

Figure 3.1 TRANSACTION STATES

The states 1 and 2 have the common characteristic, scheduled to wait for a certain duration of time before competing for next facility. The state 1, however, until the involved TX enters the system for the first time, takes place outside of the system with no effect on the system at all.

A TX enters a blocked state if the facility it is competing for is busy. A blocked TX resumes competing upon each transition. The state 4 has not yet been implemented in MICROSS, although provisions are made to include it. The state 5 is obvious. The transactions, be it control or data, come to an end at a particular host or communication node. This state is referred to as TX termination state later in the simulation and reporting parts.

The facilities involved regarding the simulation model are host computers and communication processors, and the transmission medium with host-to-communication subsystem interface and communication-to-communication processor connection.

### 3.2 Basic MICROSS software system

In view of the general modelling aspects mentioned in the previous parts the presentation in this part covers basic descriptions of main components of the MICROSS software system.

MICROSS is organized in the form of three loosely tied submodels and two utilities:

1. Definition
2. Simulation
3. Reporting
4. Restart
5. System snapshot.

The interface between all five is monitored under the control of a small MONITOR.

These main constructs are also transparent to the user. While he is guided interactively through the MICROSS system he will know the submodel in charge of the current action, by the prompt carrying the name of the submodel. Each model has well defined interface with the monitor. There is no control from one to another unless it comes through the monitor.

In this section basic tasks undertaken by each submodel are introduced at a higher level. Further details are included in the User Manual.

### 3.2.1 Control of MICROSS submodels: MONITOR

The MONITOR routine shows all the global data structures with

control over user and other submodels of MICROSS. Figure 3.2 shows the system flowchart of MONITOR. With the interactive control the user can switch between the submodels as many times as found necessary until a convincing architecture is achieved, judged by the analysis of the performance results of each alternative.

MONITOR satisfies the need of clear user interface with MICROSS. The MONITOR is the only path to enter a subsystem and also the only path to exit the system properly.

### 3.2.2 System definition and initialisation

This section provides all the data necessary for the simulation regarding the capabilities of the hardware components such as host computers and communication subsystem, and application such as patterns of external message send requests generated at the hosts. The upper limits are put for modelling constructs such as scheduling lists, and queuing buffers at host and communication subsystem. The options regarding the communication protocols and routine techniques are also specified in this section.

The data structures used to implement simulation constructs and also statistics on the facilities are initiated in this system, as well. The system data can be grouped into four classes:

# MONITOR

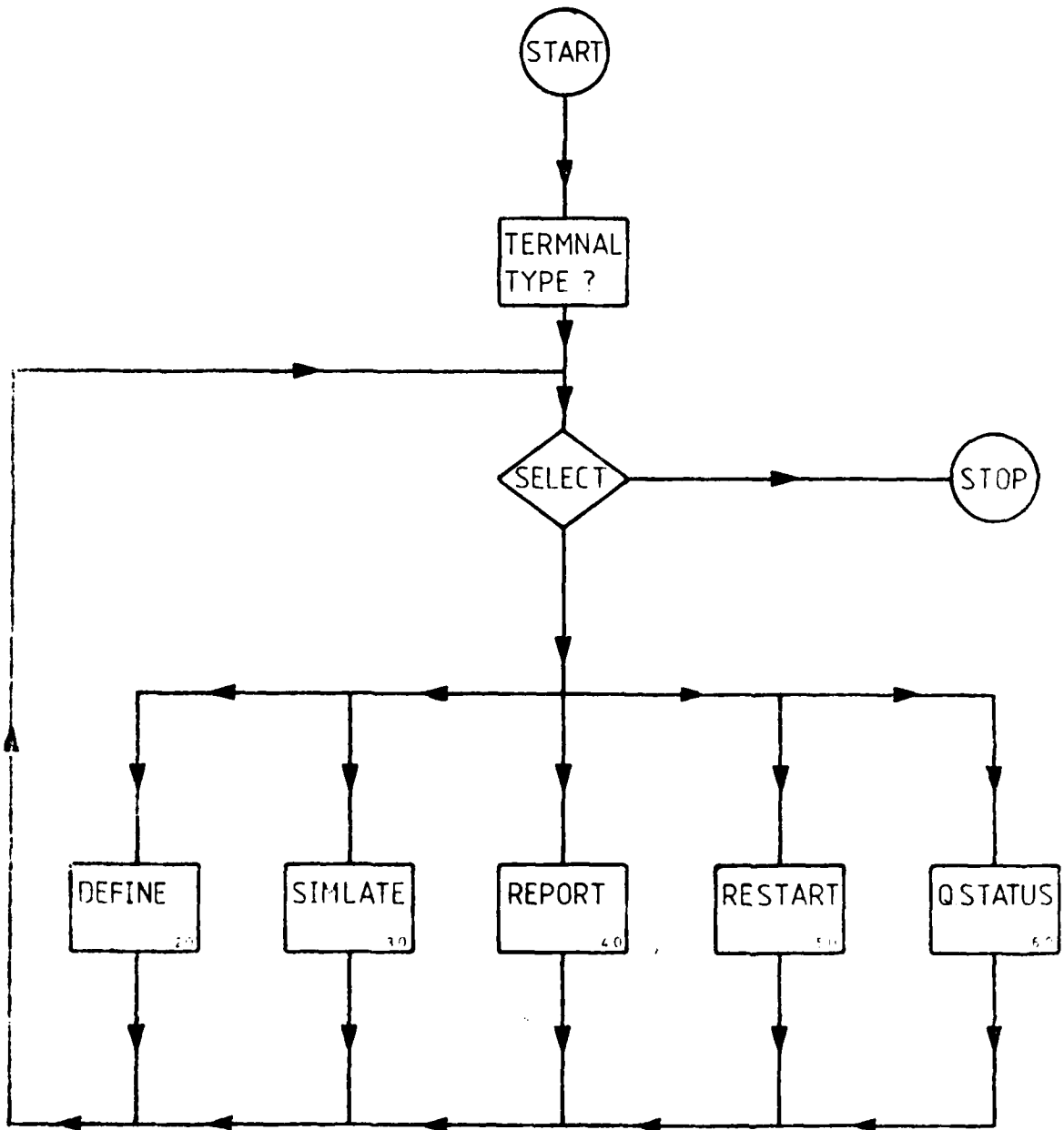

Figure 3.2 MONITOR

A. Topology Definition

Providing he stays within limits imposed by the system, a user can either select his topology from a range of 'regular' and 'standard' topologies or define an irregular network using either interactive graphical input or by means of a connection table. An option available to interactive users is to construct their network with a geographical map as background.

After definition the topology information can be stored in a data file for future use.

B. Hardware Data

- Speed of local processor: kilo instructions/sec.
- Speed of Communication processor: kilo instructions/sec.
- Speed of local transmission medium: kilo bits/sec.
- Speed of the lines between communication nodes:  
kilo bits/sec.
- Local memory at the host for communication software only: kilo bytes
- Communication memory at the communication processor:  
kilo bytes.
- Output queue lengths in terms of number of messages.

The processor speeds are used to simulate the seizure

duration of the processors given a task requiring a certain number of instructions. Memory size, on the other hand, is checked for the sufficient buffer space and is not a critical factor with the low cost factor involved. The lines delay the transactions by an amount proportional to their (TX's) length.

### C. Routing Data

- The routing technique: once decided upon, is applied system-wide. As far as a user is concerned, it can be parameterized for certain well known routing techniques which will be embedded. In the current MICROSS system, two variations of fixed routing have already been implemented. The flooding as well as an adaptive routing technique is being implemented.
  
- Communication protocols: these are also parameterized. Each protocol is simulated by a fixed delay time depending on the complexity involved. The protocols covered are hop-to-hop HDLC protocol, BISYNCH, X25 and a simple handshake. User defined protocols can be incorporated with minor changes, as long as the store-and-forward aspect of the DCS is obeyed.

D. Application Data

- Application data is modelled in terms of the frequency of external message input at each node and a traffic matrix indicating the traffic flow requirements between node pairs. The former is presented in terms of message inter arrival times and the probability distribution function. The latter is presented in terms of a probability matrix. Optionally, actual traffic can be used to feed to the simulated system. This approach is most helpful in testing the model against an existing counterpart.

The traffic can also be grouped into a number of priority classes.

At various points throughout the definition phase the user is given the opportunity to store his specific data on files. This aids in the construction of more exact system models.

### 3.2.3 Simulation Subsystem

#### MICROSS simulation concept

The simulation subsystem utilizes every structure defined and/or reset in the definition subsystem. The software modularity is attempted by functional partitioning so that easy access by the user is possible. There are two disjoint but closely related

sets of functions at higher level. The event (TX) scheduling in time and priority, activation of a particular TX at a point in time (current time), advancement of global time as well as updating the status of the facilities at that instant of current time are all carried out in one of these disjoint sets of subroutines (using FORTRAN language terminology). The other set of subroutines handles the facility seizure upon activation of a particular TX. The seizure can take place because of one of the following functions:

1. Arrival of an external TX at the host computer.
2. Local transmission attempt between the host and the local communication node.
3. Receipt of local external messages at the communication node.
4. Receipt of remote traffic at the communication node.
5. Data transmission requests between two communication nodes.
6. Scheduling the amount of external traffic.

The model provides a degree of interaction between some of the functions. For example, data transmission request at one side of a pair triggers the other side for reception.

The last item, i.e. 6, does not involve seizure of a facility. The pattern of scheduling at a node depends on the application data parameters fed in during system initialization.

Arrival of a message is scheduled but is not guaranteed to be handled at the host right away unless the host is free.

The first five functions may require queuing at one facility and dequeuing at the other depending on the success of action that has taken place, and also the protocols involved. For example if the protocol chosen is an HDLC utilizing hop-to-hop with piggy-back acknowledgement then an arriving message is queued as soon as transmission is complete. Its copy in the sending node is not removed from the queue unless its receipt is acknowledged.

The acknowledgement, queuing and dequeuing operations are performed during the receive action of the host and/or the communication node.

Timing of each operation is necessary to affect the seizure duration of the facility in question. The smallest time increment corresponds to shortest independent process (function). For example, an attempt to transmit by a sender may be aborted because of the busy state of the receiver. However, this attempt itself is an executable process and is timed according to the number of instructions and speed of the processor performing it. Thus the attempted TX is rescheduled to be ready for re-attempt at a later time.

Figure 2.1 shows two nodes as they are simulated by MICROSS, which appears as a network of queues. The host contains one

output queue leading to the local communication node via a link. Communication node possesses  $m$  queues leading to  $m$  other communication nodes and another queue leading to the local host part.

The details of the data structure used to represent the facilities are summarized in the next section.

#### MICROSS basic data structure

The MICROSS data structure can be grouped into four main classes which are closely interlinked:

1. Physical components.
2. Status of physical components.
3. Application traffic and routing.
4. Book-keeping constructs.

Figure 3.3 displays the presentation of the physical components and the related statistics, for all except queues the specification data and status data are given in a simple array type data structure. Queue representation requires higher sophistication. The representation of an output queue is a linked list structure. The status data is kept in a separate array. For modularity reasons each queue is also associated on a separate data area to store the actual messages.

The index of a message in the data area is kept in the right

- |  |                                 |
|--|---------------------------------|
| 1. Processor id number.                              | 1. Processor id.                |
| 2. Instruction execution speed(KIPS).                | 2. Execution speed (KIPS)       |
| 3. Memory size (KBYTE).                              | 3. Number of output ports.      |
| 4. Total external input in number of transactions*   | 4. Number of input ports.       |
| 5. Total number of TXs received*                     | 5. Memory size (KBYTE)          |
| 6. Mean inter-arrival time of external input.        | 6. Total number of TX received* |
| 7. Total busy time*                                  | 7. Total number of TX sent*     |
| 8. Status (1-busy, 0-free)                           | 8. (unused).                    |
| 9. Time scheduled to                                 | 9. Total busy time*             |
| 10. Total time the arriving TSx spent in the system* | 10. Status (0-free-1-busy)      |
| 11. Protocol handling time                           | 11. Time scheduled to be free.  |
|  | 12. Protocol handling time      |
- 
- |                       |                       |
|-----------------------|-----------------------|
| (a) LP Representation | (b) CP Representation |
|-----------------------|-----------------------|
- 
- |                                       |                              |
|---------------------------------------|------------------------------|
| 1. Link id.                           | 1. Queue id.                 |
| 2. Transmission capacity (K bits/sec) | 2. Queue length.             |
| 3. Total busy time*                   | 3. Current content           |
| 4. Total number of TXs handled.       | 4. Total occupancy time*     |
| 5. Status (0-free, 1-busy).           | 5. Total number TX departed* |
| 6. Time scheduled.                    | 6. Status (empty, full)      |
| 7. Transmission time (us)/bit         | 7. Send no. of last TX sent. |
| (*) Statistics                        | 8. Maximum content           |
|                                       | 9. Reserved                  |
- 
- |                           |                         |
|---------------------------|-------------------------|
| (c) L-Link representation | (d) Output Queue status |
|---------------------------|-------------------------|
- 
- |                                 |                          |
|---------------------------------|--------------------------|
| 1. TX id.                       | 1. Data send seq. no.    |
| 2. Current time                 | 2. ack send seq. no.     |
| 3. Index of TX in the data area | 3. data receive seq. no. |
| 4. Front pointer                | 4. ack receive seq. no.  |
| 5. TX send sequence no.         | 5. validity flag         |
| 6. (unused)                     |                          |
- 
- |                              |                           |
|------------------------------|---------------------------|
| (e) An entry of output Queue | (f) Acknowledgement table |
|------------------------------|---------------------------|

Figure 3.3 BASIC DATA STRUCTURE LAYOUTS

queue. Therefore no search is necessary for retrieval.

Further data structures are added depending on the protocols employed. For example, for HDLC protocol, utilizing piggy-back window mechanism for acknowledgement another structure is employed to record the relevant data for each queue.

The application data structure consists of an  $n \times n$  traffic matrix where each entry  $T_{ij}$  indicates the proportion of the traffic sourced at  $i$  and destined for  $j$ .

The routing constructs depend on the specific technique implemented. For fixed routing technique an  $n \times n$  routing matrix ( $R$ ) where  $R_{ij}$  indicates next node after  $i$  on the path to  $j$  is the main structure. As support constructs, we have connection table (ICONT) where each row is a set of adjacent nodes of the corresponding node, and weight table  $W$  where each  $W_{ij}$  indicates the minimum distance between node  $i$  and  $j$  in terms of weight associated to each link on the path  $(i, j)$ .

Two main book-keeping data constructs (LISTX, IACTX) are employed to hold the list of scheduled but inactive transactions, and corresponding active transactions. The TXs pingpong between these two lists until terminated, after which they are removed from either of the lists and also from the system altogether.

Both of these constructs are represented by linked lists in which TXs are in time and priority order. The TX information carried in these lists are:-

1. Source id of the TX
2. destination id
3. TX id
4. time the TX is scheduled at
5. the action to take place next
6. priority
7. link area
8. output queue id
9. current node id.

The TXs are added or removed from the link lists using the avail (garbage collection) lists.

The data structure allows the gathering of statistics on the utilization of the system as well as the individual physical and logical constructs.

#### 3.2.4 Reporting Subsystem

Reporting is naturally referred to only after the completion of simulation for a non-zero increment of time. Once it is entered the level of reporting details is chosen by the user. The small flow diagram in Figure 3.4 shows the reporting options available in MICROSS.

# REPORT

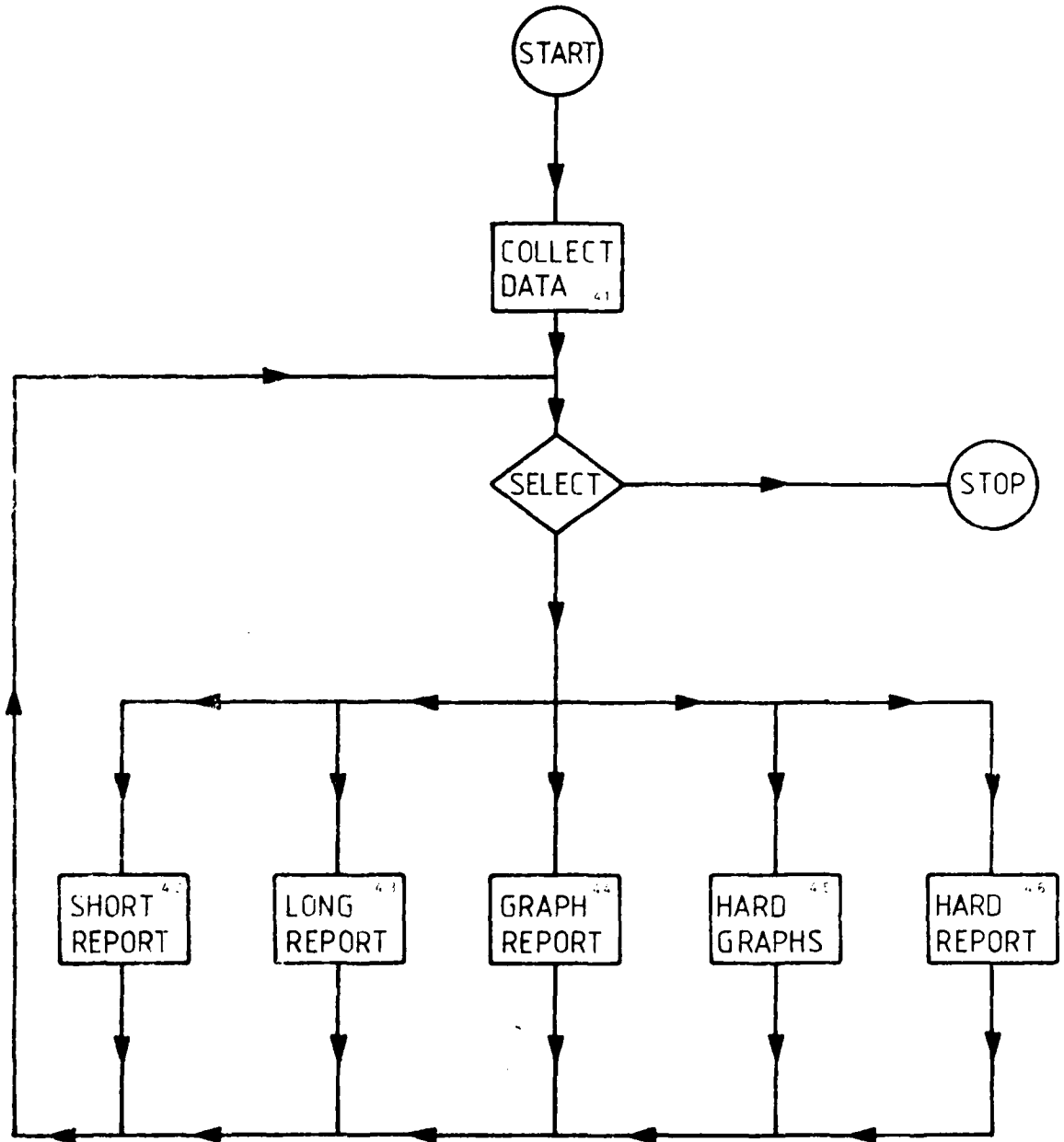

Figure 3.4 REPORTING OPTIONS

A short report displays the main system description data as well as the results concerning the throughput and average delay time experienced. Figure 3.5 presents such a report for a 16 node cross-connected regular and homogeneous DCS. In Figure 3.5, each row of connection tables shows the set of adjacent nodes.

The long report option gives details of External Input, Node Content, Delivered, Received and Unacknowledged Messages, Response Times and Utilisation of Host and Communication Processors, Output Queues and Communication Links separately. A full set of reports for the 16 node system is given in Figure 3.6.

The graphics report produces four graphs showing

1. Response Time statistics
2. Nodal Statistics
3. Utilisation Statistics
4. Output Queue Status.

Examples (again for the 16 node system) are given in Figure 3.7 (a-d).

Notice that the Output Queue Status report is essentially identical to the System Snapshot option in MONITOR: in both cases an arrow represents a link in the direction shown and vertical bars behind the arrow represent messages in the relevant output queue.

```

SIMULATION DURATION (seconds)           =      0.10
AVERAGE DELAY TIME (microseconds)      = 15964.6
TOTAL EXTERNAL TRAFFIC                  =      786
TOTAL HOST CONTENT                       =      17
MESSAGES IN COMMUNICATION SUBSYSTEM     =      47
MESSAGES DELIVERED                      =     722
TOTAL DELIVERED BUT UNACKNOWLEDGED      =       0
PERCENTAGE OF UNACKNOWLEDGED            =      5.0
    
```

\*\*\*\*\*  
 TOTAL TRAFFIC STATISTICS IN NUMBER OF MESSAGES  
 \*\*\*\*\*

| HOST ID | EXTERNAL INPUT | DELIVERED | UNACKNOWLEDGED | CURRENT CONTENT | RECEIVED MESSAGES | MESSAGE TL. Q. |
|---------|----------------|-----------|----------------|-----------------|-------------------|----------------|
| 1       | 50             | 46        | 0              | 1               | 49                | 1              |
| 2       | 50             | 47        | 0              | 1               | 53                | 2              |
| 3       | 49             | 46        | 0              | 1               | 48                | 3              |
| 4       | 49             | 45        | 0              | 1               | 60                | 4              |
| 5       | 49             | 45        | 0              | 1               | 44                | 5              |
| 6       | 49             | 45        | 0              | 1               | 41                | 1              |
| 7       | 49             | 44        | 0              | 1               | 50                | 3              |
| 8       | 49             | 45        | 0              | 1               | 48                | 5              |
| 9       | 49             | 45        | 0              | 1               | 43                | 3              |
| 10      | 49             | 45        | 0              | 1               | 36                | 2              |
| 11      | 49             | 45        | 0              | 1               | 41                | 3              |
| 12      | 49             | 44        | 0              | 1               | 42                | 0              |
| 13      | 49             | 45        | 0              | 1               | 48                | 1              |
| 14      | 49             | 46        | 0              | 1               | 34                | 1              |
| 15      | 49             | 45        | 0              | 1               | 35                | 2              |
| 16      | 49             | 44        | 0              | 2               | 50                | 4              |
| TOTALS  | 786            | 722       | 0              | 17              | 722               | 47             |

\*\*\*\*\*

\*\*\*\*\*  
 CONNECTION TABLE  
 \*\*\*\*\*

| NODE | CONTIVITY | NEIGHBOURS |
|------|-----------|------------|
| 1    | 4         | 2 4 5 13   |
| 2    | 4         | 1 3 6 14   |
| 3    | 4         | 2 4 7 15   |
| 4    | 4         | 1 3 8 16   |
| 5    | 4         | 1 6 8 9    |
| 6    | 4         | 2 5 7 10   |
| 7    | 4         | 3 6 8 11   |
| 8    | 4         | 4 5 7 12   |
| 9    | 4         | 5 10 12 13 |
| 10   | 4         | 6 9 11 14  |
| 11   | 4         | 7 10 12 15 |
| 12   | 4         | 8 9 11 16  |
| 13   | 4         | 1 9 14 16  |
| 14   | 4         | 2 10 13 15 |
| 15   | 4         | 3 11 14 16 |
| 16   | 4         | 4 12 13 15 |

\*\*\*\*\*

Figure 3.5 A SHORT REPORT

| EXTERNAL MESSAGE STATUS                     |   |           |        |        |      |  |
|---|---|-----------|--------|--------|------|--|
| ENTRIES                                     | AVERAGE                                   | STD DEVTN |        |        |      |  |
| 16  | 45.17                                     | 0.94      |        |        |      |  |
| UPPER OBSERVED PER CENT CUMULATIVE MULTIPLE | LIMIT FREQUENCY OF TOTAL PER CENT OF PEAK |           |        |        |      |  |
| 36  | 3   | 18.75     | 18.75  | 50.00  | 0.80 |  |
| 44  | 5   | 24.25     | 50.00  | 68.75  | 0.98 |  |
| 48  | 3   | 18.75     | 68.75  | 87.50  | 1.06 |  |
| 52  | 3   | 18.75     | 87.50  | 93.75  | 1.15 |  |
| 56  | 1   | 6.25      | 93.75  | 100.00 | 1.24 |  |
| 60  | 1   | 6.25      | 100.00 |        | 1.33 |  |
| DELIVERED BUT UNACKNOWLEDGED STATUS         |   |           |        |        |      |  |
| ENTRIES                                     | AVERAGE                                   | STD DEVTN |        |        |      |  |
| 16  | 0.00                                      | 0.00      |        |        |      |  |
| UPPER OBSERVED PER CENT CUMULATIVE MULTIPLE | LIMIT FREQUENCY OF TOTAL PER CENT OF PEAK |           |        |        |      |  |
| 0   | 16  | 100.00    | 100.00 |        | 0.00 |  |
| UNACKNOWLEDGED AT HOST STATUS               |   |           |        |        |      |  |
| ENTRIES                                     | AVERAGE                                   | STD DEVTN |        |        |      |  |
| 11  | 0.00                                      | 0.00      |        |        |      |  |
| UPPER OBSERVED PER CENT CUMULATIVE MULTIPLE | LIMIT FREQUENCY OF TOTAL PER CENT OF PEAK |           |        |        |      |  |
| 0   | 16  | 100.00    | 100.00 |        | 0.00 |  |

| EXTERNAL MESSAGE STATUS                     |   |           |        |  |      |  |
|---|---|-----------|--------|--|------|--|
| ENTRIES                                     | AVERAGE                                   | STD DEVTN |        |  |      |  |
| 16  | 49.17                                     | 0.71      |        |  |      |  |
| UPPER OBSERVED PER CENT CUMULATIVE MULTIPLE | LIMIT FREQUENCY OF TOTAL PER CENT OF PEAK |           |        |  |      |  |
| 52  | 16  | 100.00    | 100.00 |  | 1.06 |  |
| NODE CONTENT STATUS                         |   |           |        |  |      |  |
| ENTRIES                                     | AVERAGE                                   | STD DEVTN |        |  |      |  |
| 16  | 1.00                                      | 0.25      |        |  |      |  |
| UPPER OBSERVED PER CENT CUMULATIVE MULTIPLE | LIMIT FREQUENCY OF TOTAL PER CENT OF PEAK |           |        |  |      |  |
| 1   | 15  | 93.75     | 93.75  |  | 0.94 |  |
| 2   | 1   | 6.25      | 100.00 |  | 1.88 |  |
| DELIVERED MESSAGE STATUS                    |   |           |        |  |      |  |
| ENTRIES                                     | AVERAGE                                   | STD DEVTN |        |  |      |  |
| 16  | 45.17                                     | 0.94      |        |  |      |  |
| UPPER OBSERVED PER CENT CUMULATIVE MULTIPLE | LIMIT FREQUENCY OF TOTAL PER CENT OF PEAK |           |        |  |      |  |
| 48  | 10  | 93.75     | 93.75  |  | 1.06 |  |
| 52  | 1   | 6.25      | 100.00 |  | 1.24 |  |

Figure 3.6 LONG REPORT

HOST RESOURCE STATISTICS

| NODE ID | MEMORY SIZE KB | EXTERNAL ENTRIES | AVERAGE CONTENT | CURRENT CONTENT | MAXIMUM CONTENT | UTILIZATION PER CNT |
|---------|----------------|------------------|-----------------|-----------------|-----------------|---------------------|
| 1       | 100            | 50               | 0.88            | 1               | 1               | 95.75               |
| 2       | 100            | 50               | 0.87            | 1               | 1               | 90.28               |
| 3       | 100            | 49               | 0.88            | 1               | 1               | 80.64               |
| 4       | 100            | 49               | 0.86            | 1               | 1               | 77.91               |
| 5       | 100            | 49               | 0.87            | 1               | 1               | 64.22               |
| 6       | 100            | 49               | 0.87            | 1               | 1               | 60.20               |
| 7       | 100            | 49               | 0.88            | 1               | 1               | 57.40               |
| 8       | 100            | 49               | 0.87            | 1               | 1               | 57.43               |
| 9       | 100            | 49               | 0.87            | 1               | 1               | 50.150              |
| 10      | 100            | 49               | 0.87            | 1               | 1               | 50.150              |
| 11      | 100            | 49               | 0.87            | 1               | 1               | 50.150              |
| 12      | 100            | 49               | 0.87            | 1               | 1               | 50.150              |
| 13      | 100            | 49               | 0.87            | 1               | 1               | 50.150              |
| 14      | 100            | 49               | 0.87            | 1               | 1               | 50.150              |
| 15      | 100            | 49               | 0.87            | 1               | 1               | 50.150              |
| 16      | 100            | 49               | 0.86            | 2               | 2               | 50.150              |

COMM PROCESSOR STATISTICS

| NODE ID | MEMORY SIZE KB | ROUTED ENTRIES | AVERAGE CONTENT | CURRENT CONTENT | MAXIMUM CONTENT | UTILIZATION PER CNT |
|---------|----------------|----------------|-----------------|-----------------|-----------------|---------------------|
| 1       | 10             | 164            | 2.88            | 5               | 15              | 95.75               |
| 2       | 10             | 155            | 2.82            | 3               | 15              | 90.28               |
| 3       | 10             | 152            | 2.73            | 3               | 14              | 80.64               |
| 4       | 10             | 178            | 3.15            | 4               | 16              | 77.91               |
| 5       | 10             | 148            | 2.64            | 3               | 14              | 64.22               |
| 6       | 10             | 154            | 2.87            | 3               | 14              | 60.20               |
| 7       | 10             | 154            | 2.44            | 3               | 14              | 57.40               |
| 8       | 10             | 151            | 2.64            | 3               | 14              | 57.43               |
| 9       | 10             | 145            | 2.67            | 3               | 14              | 50.150              |
| 10      | 10             | 130            | 2.70            | 4               | 15              | 50.150              |
| 11      | 10             | 130            | 2.73            | 3               | 15              | 50.150              |
| 12      | 10             | 147            | 2.61            | 3               | 15              | 50.150              |
| 13      | 10             | 153            | 2.80            | 4               | 16              | 50.150              |
| 14      | 10             | 131            | 2.77            | 3               | 15              | 50.150              |
| 15      | 10             | 152            | 2.77            | 3               | 15              | 50.150              |
| 16      | 10             | 150            | 2.95            | 4               | 15              | 50.150              |

RESOURCE TIME USAGE

| ENTRIES | ALPHA1F  | STD DEVCH |
|---------|----------|-----------|
| 721     | 15364.65 | 348.52    |
| 14      | 1.04     | 1.94      |
| 187     | 25.94    | 27.88     |
| 12      | 1.66     | 29.54     |
| 286     | 0.14     | 29.68     |
| 8       | 39.67    | 69.35     |
| 4       | 1.11     | 70.46     |
| 171     | 0.55     | 71.01     |
| 2       | 23.72    | 14.73     |
| 36      | 0.28     | 95.01     |
| 1850    | 4.99     | 100.00    |
| 13746   |          |           |
| 15642   |          |           |
| 15879   |          |           |
| 17775   |          |           |
| 19671   |          |           |
| 19968   |          |           |
| 21804   |          |           |
| 23700   |          |           |

Figure 3.6

NEW LINE STATISTICS

| LRSC               | TYPE | NEED | LOCAL | UNL | UNL |
|--------------------|------|------|-------|-----|-----|
| 70                 |      |      | 70    | 70  | 70  |
| SOURCE PROCESSOR 1 |      |      |       |     |     |
| 2                  | 1    | 0    | 0     | 0   | 0   |
| 3                  | 2    | 0    | 0     | 0   | 0   |
| 4                  | 3    | 0    | 0     | 0   | 0   |
| 5                  | 4    | 0    | 0     | 0   | 0   |
| 6                  | 5    | 0    | 0     | 0   | 0   |
| 7                  | 6    | 0    | 0     | 0   | 0   |
| 8                  | 7    | 0    | 0     | 0   | 0   |
| 9                  | 8    | 0    | 0     | 0   | 0   |
| 10                 | 9    | 0    | 0     | 0   | 0   |
| 11                 | 10   | 0    | 0     | 0   | 0   |
| 12                 | 11   | 0    | 0     | 0   | 0   |
| 13                 | 12   | 0    | 0     | 0   | 0   |
| 14                 | 13   | 0    | 0     | 0   | 0   |
| 15                 | 14   | 0    | 0     | 0   | 0   |
| 16                 | 15   | 0    | 0     | 0   | 0   |
| 17                 | 16   | 0    | 0     | 0   | 0   |
| 18                 | 17   | 0    | 0     | 0   | 0   |
| 19                 | 18   | 0    | 0     | 0   | 0   |
| 20                 | 19   | 0    | 0     | 0   | 0   |
| 21                 | 20   | 0    | 0     | 0   | 0   |
| 22                 | 21   | 0    | 0     | 0   | 0   |
| 23                 | 22   | 0    | 0     | 0   | 0   |
| 24                 | 23   | 0    | 0     | 0   | 0   |
| 25                 | 24   | 0    | 0     | 0   | 0   |
| 26                 | 25   | 0    | 0     | 0   | 0   |
| 27                 | 26   | 0    | 0     | 0   | 0   |
| 28                 | 27   | 0    | 0     | 0   | 0   |
| 29                 | 28   | 0    | 0     | 0   | 0   |
| 30                 | 29   | 0    | 0     | 0   | 0   |
| 31                 | 30   | 0    | 0     | 0   | 0   |
| 32                 | 31   | 0    | 0     | 0   | 0   |
| 33                 | 32   | 0    | 0     | 0   | 0   |
| 34                 | 33   | 0    | 0     | 0   | 0   |
| 35                 | 34   | 0    | 0     | 0   | 0   |
| 36                 | 35   | 0    | 0     | 0   | 0   |
| 37                 | 36   | 0    | 0     | 0   | 0   |
| 38                 | 37   | 0    | 0     | 0   | 0   |
| 39                 | 38   | 0    | 0     | 0   | 0   |
| 40                 | 39   | 0    | 0     | 0   | 0   |
| 41                 | 40   | 0    | 0     | 0   | 0   |
| 42                 | 41   | 0    | 0     | 0   | 0   |
| 43                 | 42   | 0    | 0     | 0   | 0   |
| 44                 | 43   | 0    | 0     | 0   | 0   |
| 45                 | 44   | 0    | 0     | 0   | 0   |
| 46                 | 45   | 0    | 0     | 0   | 0   |
| 47                 | 46   | 0    | 0     | 0   | 0   |
| 48                 | 47   | 0    | 0     | 0   | 0   |
| 49                 | 48   | 0    | 0     | 0   | 0   |
| 50                 | 49   | 0    | 0     | 0   | 0   |
| 51                 | 50   | 0    | 0     | 0   | 0   |
| 52                 | 51   | 0    | 0     | 0   | 0   |
| 53                 | 52   | 0    | 0     | 0   | 0   |
| 54                 | 53   | 0    | 0     | 0   | 0   |
| 55                 | 54   | 0    | 0     | 0   | 0   |
| 56                 | 55   | 0    | 0     | 0   | 0   |
| 57                 | 56   | 0    | 0     | 0   | 0   |
| 58                 | 57   | 0    | 0     | 0   | 0   |
| 59                 | 58   | 0    | 0     | 0   | 0   |
| 60                 | 59   | 0    | 0     | 0   | 0   |
| 61                 | 60   | 0    | 0     | 0   | 0   |
| 62                 | 61   | 0    | 0     | 0   | 0   |
| 63                 | 62   | 0    | 0     | 0   | 0   |
| 64                 | 63   | 0    | 0     | 0   | 0   |
| 65                 | 64   | 0    | 0     | 0   | 0   |
| 66                 | 65   | 0    | 0     | 0   | 0   |
| 67                 | 66   | 0    | 0     | 0   | 0   |
| 68                 | 67   | 0    | 0     | 0   | 0   |
| 69                 | 68   | 0    | 0     | 0   | 0   |
| 70                 | 69   | 0    | 0     | 0   | 0   |
| 71                 | 70   | 0    | 0     | 0   | 0   |
| 72                 | 71   | 0    | 0     | 0   | 0   |
| 73                 | 72   | 0    | 0     | 0   | 0   |
| 74                 | 73   | 0    | 0     | 0   | 0   |
| 75                 | 74   | 0    | 0     | 0   | 0   |
| 76                 | 75   | 0    | 0     | 0   | 0   |
| 77                 | 76   | 0    | 0     | 0   | 0   |
| 78                 | 77   | 0    | 0     | 0   | 0   |
| 79                 | 78   | 0    | 0     | 0   | 0   |
| 80                 | 79   | 0    | 0     | 0   | 0   |
| 81                 | 80   | 0    | 0     | 0   | 0   |
| 82                 | 81   | 0    | 0     | 0   | 0   |
| 83                 | 82   | 0    | 0     | 0   | 0   |
| 84                 | 83   | 0    | 0     | 0   | 0   |
| 85                 | 84   | 0    | 0     | 0   | 0   |
| 86                 | 85   | 0    | 0     | 0   | 0   |
| 87                 | 86   | 0    | 0     | 0   | 0   |
| 88                 | 87   | 0    | 0     | 0   | 0   |
| 89                 | 88   | 0    | 0     | 0   | 0   |
| 90                 | 89   | 0    | 0     | 0   | 0   |
| 91                 | 90   | 0    | 0     | 0   | 0   |
| 92                 | 91   | 0    | 0     | 0   | 0   |
| 93                 | 92   | 0    | 0     | 0   | 0   |
| 94                 | 93   | 0    | 0     | 0   | 0   |
| 95                 | 94   | 0    | 0     | 0   | 0   |
| 96                 | 95   | 0    | 0     | 0   | 0   |
| 97                 | 96   | 0    | 0     | 0   | 0   |
| 98                 | 97   | 0    | 0     | 0   | 0   |
| 99                 | 98   | 0    | 0     | 0   | 0   |
| 100                | 99   | 0    | 0     | 0   | 0   |
| 101                | 100  | 0    | 0     | 0   | 0   |
| 102                | 101  | 0    | 0     | 0   | 0   |
| 103                | 102  | 0    | 0     | 0   | 0   |
| 104                | 103  | 0    | 0     | 0   | 0   |
| 105                | 104  | 0    | 0     | 0   | 0   |
| 106                | 105  | 0    | 0     | 0   | 0   |
| 107                | 106  | 0    | 0     | 0   | 0   |
| 108                | 107  | 0    | 0     | 0   | 0   |
| 109                | 108  | 0    | 0     | 0   | 0   |
| 110                | 109  | 0    | 0     | 0   | 0   |
| 111                | 110  | 0    | 0     | 0   | 0   |
| 112                | 111  | 0    | 0     | 0   | 0   |
| 113                | 112  | 0    | 0     | 0   | 0   |
| 114                | 113  | 0    | 0     | 0   | 0   |
| 115                | 114  | 0    | 0     | 0   | 0   |
| 116                | 115  | 0    | 0     | 0   | 0   |
| 117                | 116  | 0    | 0     | 0   | 0   |
| 118                | 117  | 0    | 0     | 0   | 0   |
| 119                | 118  | 0    | 0     | 0   | 0   |
| 120                | 119  | 0    | 0     | 0   | 0   |
| 121                | 120  | 0    | 0     | 0   | 0   |
| 122                | 121  | 0    | 0     | 0   | 0   |
| 123                | 122  | 0    | 0     | 0   | 0   |
| 124                | 123  | 0    | 0     | 0   | 0   |
| 125                | 124  | 0    | 0     | 0   | 0   |
| 126                | 125  | 0    | 0     | 0   | 0   |
| 127                | 126  | 0    | 0     | 0   | 0   |
| 128                | 127  | 0    | 0     | 0   | 0   |
| 129                | 128  | 0    | 0     | 0   | 0   |
| 130                | 129  | 0    | 0     | 0   | 0   |
| 131                | 130  | 0    | 0     | 0   | 0   |
| 132                | 131  | 0    | 0     | 0   | 0   |
| 133                | 132  | 0    | 0     | 0   | 0   |
| 134                | 133  | 0    | 0     | 0   | 0   |
| 135                | 134  | 0    | 0     | 0   | 0   |
| 136                | 135  | 0    | 0     | 0   | 0   |
| 137                | 136  | 0    | 0     | 0   | 0   |
| 138                | 137  | 0    | 0     | 0   | 0   |
| 139                | 138  | 0    | 0     | 0   | 0   |
| 140                | 139  | 0    | 0     | 0   | 0   |
| 141                | 140  | 0    | 0     | 0   | 0   |
| 142                | 141  | 0    | 0     | 0   | 0   |
| 143                | 142  | 0    | 0     | 0   | 0   |
| 144                | 143  | 0    | 0     | 0   | 0   |
| 145                | 144  | 0    | 0     | 0   | 0   |
| 146                | 145  | 0    | 0     | 0   | 0   |
| 147                | 146  | 0    | 0     | 0   | 0   |
| 148                | 147  | 0    | 0     | 0   | 0   |
| 149                | 148  | 0    | 0     | 0   | 0   |
| 150                | 149  | 0    | 0     | 0   | 0   |
| 151                | 150  | 0    | 0     | 0   | 0   |
| 152                | 151  | 0    | 0     | 0   | 0   |
| 153                | 152  | 0    | 0     | 0   | 0   |
| 154                | 153  | 0    | 0     | 0   | 0   |
| 155                | 154  | 0    | 0     | 0   | 0   |
| 156                | 155  | 0    | 0     | 0   | 0   |
| 157                | 156  | 0    | 0     | 0   | 0   |
| 158                | 157  | 0    | 0     | 0   | 0   |
| 159                | 158  | 0    | 0     | 0   | 0   |
| 160                | 159  | 0    | 0     | 0   | 0   |
| 161                | 160  | 0    | 0     | 0   | 0   |
| 162                | 161  | 0    | 0     | 0   | 0   |
| 163                | 162  | 0    | 0     | 0   | 0   |
| 164                | 163  | 0    | 0     | 0   | 0   |
| 165                | 164  | 0    | 0     | 0   | 0   |
| 166                | 165  | 0    | 0     | 0   | 0   |
| 167                | 166  | 0    | 0     | 0   | 0   |
| 168                | 167  | 0    | 0     | 0   | 0   |
| 169                | 168  | 0    | 0     | 0   | 0   |
| 170                | 169  | 0    | 0     | 0   | 0   |
| 171                | 170  | 0    | 0     | 0   | 0   |
| 172                | 171  | 0    | 0     | 0   | 0   |
| 173                | 172  | 0    | 0     | 0   | 0   |
| 174                | 173  | 0    | 0     | 0   | 0   |
| 175                | 174  | 0    | 0     | 0   | 0   |
| 176                | 175  | 0    | 0     | 0   | 0   |
| 177                | 176  | 0    | 0     | 0   | 0   |
| 178                | 177  | 0    | 0     | 0   | 0   |
| 179                | 178  | 0    | 0     | 0   | 0   |
| 180                | 179  | 0    | 0     | 0   | 0   |
| 181                | 180  | 0    | 0     | 0   | 0   |
| 182                | 181  | 0    | 0     | 0   | 0   |
| 183                | 182  | 0    | 0     | 0   | 0   |
| 184                | 183  | 0    | 0     | 0   | 0   |
| 185                | 184  | 0    | 0     | 0   | 0   |
| 186                | 185  | 0    | 0     | 0   | 0   |
| 187                | 186  | 0    | 0     | 0   | 0   |
| 188                | 187  | 0    | 0     | 0   | 0   |
| 189                | 188  | 0    | 0     | 0   | 0   |
| 190                | 189  | 0    | 0     | 0   | 0   |
| 191                | 190  | 0    | 0     | 0   | 0   |
| 192                | 191  | 0    | 0     | 0   | 0   |
| 193                | 192  | 0    | 0     | 0   | 0   |
| 194                | 193  | 0    | 0     | 0   | 0   |
| 195                | 194  | 0    | 0     | 0   | 0   |
| 196                | 195  | 0    | 0     | 0   | 0   |
| 197                | 196  | 0    | 0     | 0   | 0   |
| 198                | 197  | 0    | 0     | 0   | 0   |
| 199                | 198  | 0    | 0     | 0   | 0   |
| 200                | 199  | 0    | 0     | 0   | 0   |

Figure 3.6

| AGE                 | SEX | RACE | ETHNIC | RELIG | EDUC | STAT | RESID | INCOME | WEALTH | HEALTH | ACTIVITY | PERSONALITY | ATTITUDE | ADAPTATION |
|---------------------|-----|------|--------|-------|------|------|-------|--------|--------|--------|----------|-------------|----------|------------|
| SOURCE PROCESSOR 9  |     |      |        |       |      |      |       |        |        |        |          |             |          |            |
| 1                   | 40  | 1    | 1      | 1     | 1    | 1    | 1     | 1      | 1      | 1      | 1        | 1           | 1        | 1          |
| 15                  | 40  | 1    | 1      | 1     | 1    | 1    | 1     | 1      | 1      | 1      | 1        | 1           | 1        | 1          |
| 10                  | 40  | 1    | 1      | 1     | 1    | 1    | 1     | 1      | 1      | 1      | 1        | 1           | 1        | 1          |
| 11                  | 40  | 1    | 1      | 1     | 1    | 1    | 1     | 1      | 1      | 1      | 1        | 1           | 1        | 1          |
| 12                  | 40  | 1    | 1      | 1     | 1    | 1    | 1     | 1      | 1      | 1      | 1        | 1           | 1        | 1          |
| SOURCE PROCESSOR 10 |     |      |        |       |      |      |       |        |        |        |          |             |          |            |
| 1                   | 5   | 1    | 1      | 1     | 1    | 1    | 1     | 1      | 1      | 1      | 1        | 1           | 1        | 1          |
| 11                  | 5   | 1    | 1      | 1     | 1    | 1    | 1     | 1      | 1      | 1      | 1        | 1           | 1        | 1          |
| 12                  | 5   | 1    | 1      | 1     | 1    | 1    | 1     | 1      | 1      | 1      | 1        | 1           | 1        | 1          |
| 13                  | 5   | 1    | 1      | 1     | 1    | 1    | 1     | 1      | 1      | 1      | 1        | 1           | 1        | 1          |
| 14                  | 5   | 1    | 1      | 1     | 1    | 1    | 1     | 1      | 1      | 1      | 1        | 1           | 1        | 1          |
| SOURCE PROCESSOR 11 |     |      |        |       |      |      |       |        |        |        |          |             |          |            |
| 1                   | 6   | 1    | 1      | 1     | 1    | 1    | 1     | 1      | 1      | 1      | 1        | 1           | 1        | 1          |
| 11                  | 6   | 1    | 1      | 1     | 1    | 1    | 1     | 1      | 1      | 1      | 1        | 1           | 1        | 1          |
| 12                  | 6   | 1    | 1      | 1     | 1    | 1    | 1     | 1      | 1      | 1      | 1        | 1           | 1        | 1          |
| 13                  | 6   | 1    | 1      | 1     | 1    | 1    | 1     | 1      | 1      | 1      | 1        | 1           | 1        | 1          |
| 14                  | 6   | 1    | 1      | 1     | 1    | 1    | 1     | 1      | 1      | 1      | 1        | 1           | 1        | 1          |
| SOURCE PROCESSOR 12 |     |      |        |       |      |      |       |        |        |        |          |             |          |            |
| 1                   | 8   | 1    | 1      | 1     | 1    | 1    | 1     | 1      | 1      | 1      | 1        | 1           | 1        | 1          |
| 11                  | 8   | 1    | 1      | 1     | 1    | 1    | 1     | 1      | 1      | 1      | 1        | 1           | 1        | 1          |
| 12                  | 8   | 1    | 1      | 1     | 1    | 1    | 1     | 1      | 1      | 1      | 1        | 1           | 1        | 1          |
| 13                  | 8   | 1    | 1      | 1     | 1    | 1    | 1     | 1      | 1      | 1      | 1        | 1           | 1        | 1          |
| 14                  | 8   | 1    | 1      | 1     | 1    | 1    | 1     | 1      | 1      | 1      | 1        | 1           | 1        | 1          |
| SOURCE PROCESSOR 13 |     |      |        |       |      |      |       |        |        |        |          |             |          |            |
| 1                   | 7   | 1    | 1      | 1     | 1    | 1    | 1     | 1      | 1      | 1      | 1        | 1           | 1        | 1          |
| 11                  | 7   | 1    | 1      | 1     | 1    | 1    | 1     | 1      | 1      | 1      | 1        | 1           | 1        | 1          |
| 12                  | 7   | 1    | 1      | 1     | 1    | 1    | 1     | 1      | 1      | 1      | 1        | 1           | 1        | 1          |
| 13                  | 7   | 1    | 1      | 1     | 1    | 1    | 1     | 1      | 1      | 1      | 1        | 1           | 1        | 1          |
| 14                  | 7   | 1    | 1      | 1     | 1    | 1    | 1     | 1      | 1      | 1      | 1        | 1           | 1        | 1          |
| SOURCE PROCESSOR 14 |     |      |        |       |      |      |       |        |        |        |          |             |          |            |
| 1                   | 9   | 1    | 1      | 1     | 1    | 1    | 1     | 1      | 1      | 1      | 1        | 1           | 1        | 1          |
| 11                  | 9   | 1    | 1      | 1     | 1    | 1    | 1     | 1      | 1      | 1      | 1        | 1           | 1        | 1          |
| 12                  | 9   | 1    | 1      | 1     | 1    | 1    | 1     | 1      | 1      | 1      | 1        | 1           | 1        | 1          |
| 13                  | 9   | 1    | 1      | 1     | 1    | 1    | 1     | 1      | 1      | 1      | 1        | 1           | 1        | 1          |
| 14                  | 9   | 1    | 1      | 1     | 1    | 1    | 1     | 1      | 1      | 1      | 1        | 1           | 1        | 1          |
| SOURCE PROCESSOR 15 |     |      |        |       |      |      |       |        |        |        |          |             |          |            |
| 1                   | 7   | 1    | 1      | 1     | 1    | 1    | 1     | 1      | 1      | 1      | 1        | 1           | 1        | 1          |
| 11                  | 7   | 1    | 1      | 1     | 1    | 1    | 1     | 1      | 1      | 1      | 1        | 1           | 1        | 1          |
| 12                  | 7   | 1    | 1      | 1     | 1    | 1    | 1     | 1      | 1      | 1      | 1        | 1           | 1        | 1          |
| 13                  | 7   | 1    | 1      | 1     | 1    | 1    | 1     | 1      | 1      | 1      | 1        | 1           | 1        | 1          |
| 14                  | 7   | 1    | 1      | 1     | 1    | 1    | 1     | 1      | 1      | 1      | 1        | 1           | 1        | 1          |
| SOURCE PROCESSOR 16 |     |      |        |       |      |      |       |        |        |        |          |             |          |            |
| 1                   | 9   | 1    | 1      | 1     | 1    | 1    | 1     | 1      | 1      | 1      | 1        | 1           | 1        | 1          |
| 11                  | 9   | 1    | 1      | 1     | 1    | 1    | 1     | 1      | 1      | 1      | 1        | 1           | 1        | 1          |
| 12                  | 9   | 1    | 1      | 1     | 1    | 1    | 1     | 1      | 1      | 1      | 1        | 1           | 1        | 1          |
| 13                  | 9   | 1    | 1      | 1     | 1    | 1    | 1     | 1      | 1      | 1      | 1        | 1           | 1        | 1          |
| 14                  | 9   | 1    | 1      | 1     | 1    | 1    | 1     | 1      | 1      | 1      | 1        | 1           | 1        | 1          |

Figure 3.6

The graphics output may be sent to a plotting device using reporting Option 4, and Option 5 produces a data file containing both the short and long reports.

After generating reports the user is returned to the MONITOR where he may simulate again after inputting an increment to the simulation time or he may choose one of the other options.

The simulation feedback cycle as shown in Figure 3.8 can continue until the user is satisfied with the networking characteristics of the DCS regarding topology, routing technique, communication protocol, and application traffic.

#### 4. GRAPHICS FACILITIES IN MICROSS

Graphics aid in MICROSS is utilized at 3 levels:

1. Definition
2. Simulation
3. Reporting

Graphics use in reporting is discussed in section 3.3 as a part of basic MICROSS system, and is used to display the statistics in classical sense in the form of histograms, curves, etc.

a) DELAY TIME STATISTICS

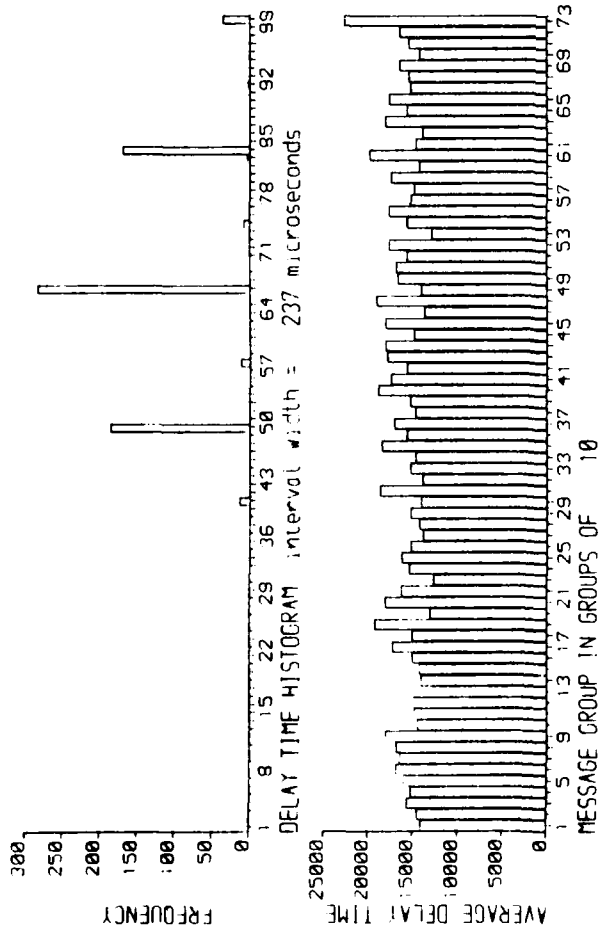

b) NODAL STATISTICS

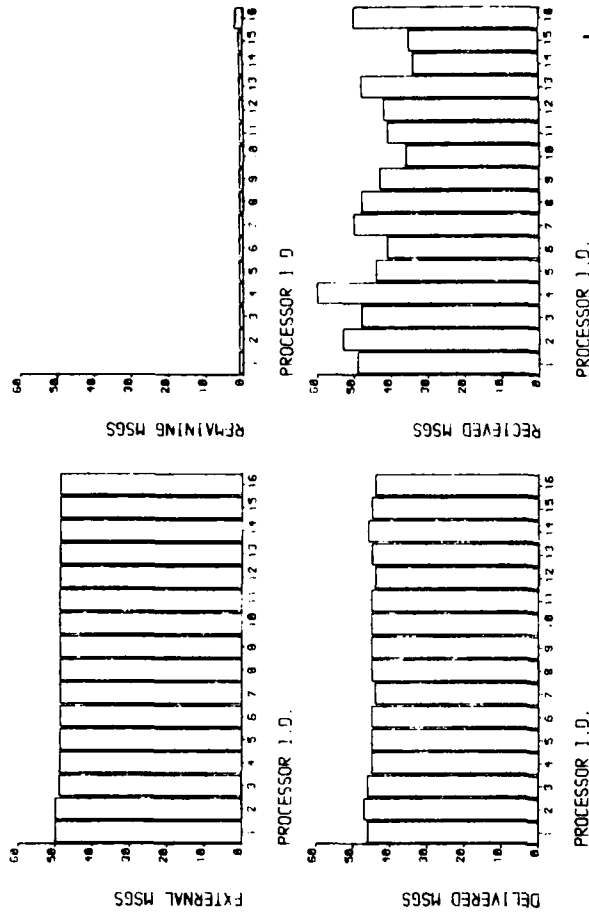

c) UTILISATION STATISTICS

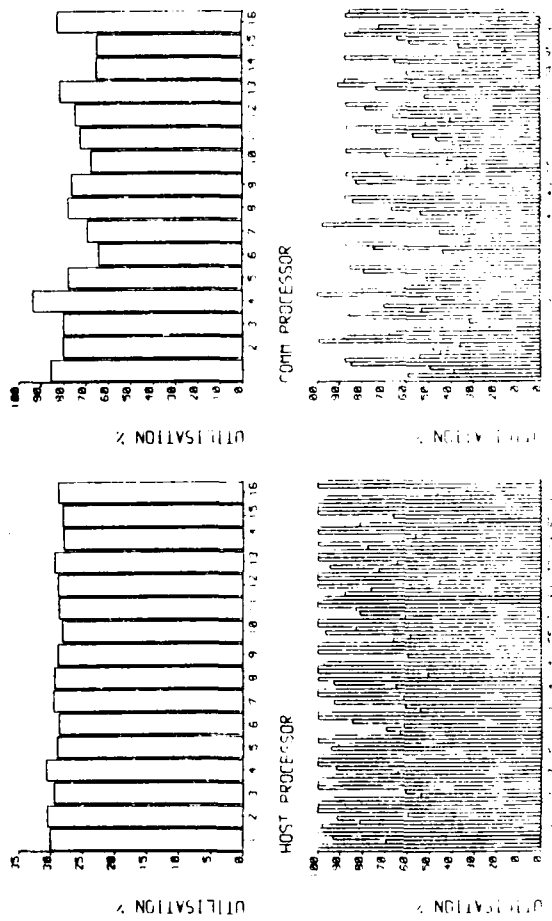

d) OUTPUT QUEUE STATUS

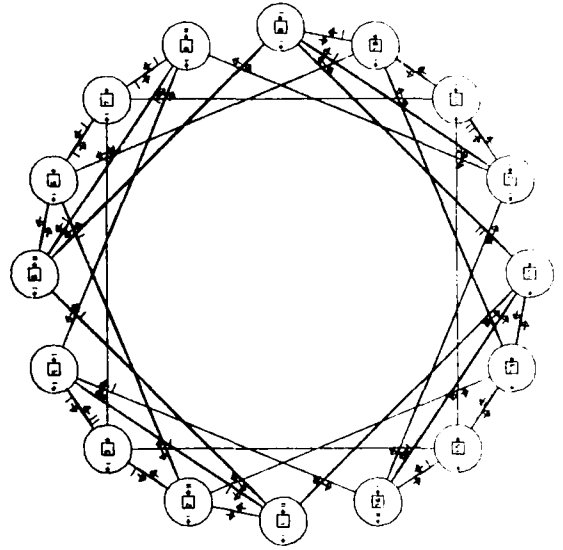

Figure 3.7 GRAPHICS REPORT

## 1.1 Graphics application to system definition

Graphics aid in definition subsystem is limited to the node level topological layouts, although technically there is no restriction on graphical details such as separation of local host from the communication node and processor from the memory. These details, especially in a densely connected environment lose their relevance and are therefore left out unless a multi-processor structure is the subject.

The topological patterns at a node level can be formed from the connection table, only if the physical coordinates of each node on the screen were also known. For regular patterns this data can be generated given the screen particulars, and the connection table which can also be found under the program control triggered by a parameter indicating a specific pattern.

For irregular structures however, the coordinates may be specified interactively under the cursor and program control. In this case the coordinates need to be saved for regeneration and/or snapshot system state display purposes.

Under the program control the cursor input is parameterized to indicate a particular drawing function such as a circle to mean a node and a line in between the two circles to mean a link. The online deletions and additions can also take place. In all cases it is the topology information that is

needed to be saved for simulation and for later display purposes.

In addition networks can be overlaid on the map of a geographical area selected from a small available set or from a user's own data file.

#### 4.2 Graphics aid at simulation level

At the simulation level graphics can be used to express the system state in a concise manner. In MICROSS this is applied to the current queue content at each node in the form of a network of queues as it is illustrated in Figure 3.7.

The simulation and the graphics representation (or snapshot) are incorporated in MONITOR section as shown in Figure 3.2 where for each snapshot the incremental simulation time is added on to the global time. The simulation can then be stopped at a point in time after the exhaustion of the last time increment.

In Figure 3.7 the circles represent the Communication Processor and the square the corresponding Local Processor; the node id is written inside the square. A straight line represents a link between two nodes and an arrow shows the direction of the link (bidirectional links have two arrows). The straight lines behind an arrow represent messages waiting in that output queue. Similarly the arrows and lines inside the Communication Processor represent the internal links between Host and Communication Processor.

# SIMULATION FEEDBACK CYCLE

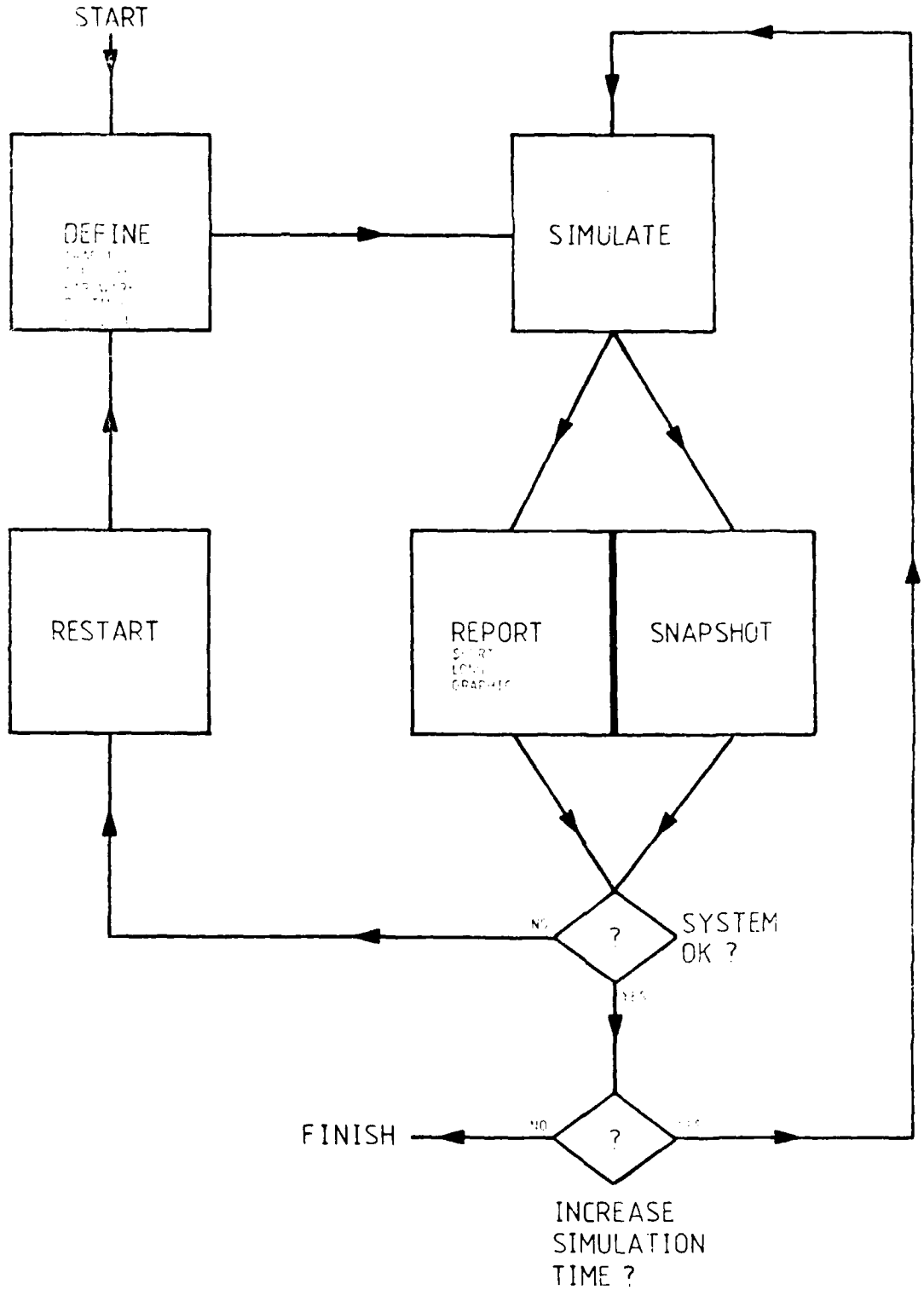

Figure 3.8 SIMULATION FEEDBACK CYCLE

## 5. PERFORMANCE EVALUATION OF INTERCONNECTION TOPOLOGIES

### 5.1 Experiment Specifications

A study has been undertaken to evaluate the performance of a wide variety on networks under the same operational conditions so as to determine the effect of topology on performance. This work also demonstrates the applicability of MICROSS to a relatively large class of network structures.

The size of networks chosen range from 9 to 16 nodes. This was due to our desire to study relatively large numbers of networks within the computational constraints that we have to operate (DEC 10 with large numbers of other users). Clearly MICROSS is able to handle much larger networks and interconnection patterns other than those given here.

A wide variety of 9 and 16 nodes 'regular' and 'standard' networks were investigated together with a few other networks of interest. Due to time and space limitation, only a subset of possible interconnection topologies is presented here.

One of the main performance characteristics of a network is the time taken for a message to be delivered to its destination since its introduction to the system called the Response Time. It is normally required that this time is as short as possible; sometimes it is essential that response time is

|                               |                   |
|-------------------------------|-------------------|
| EXTERNAL TRAFFIC DISTRIBUTION | UNIFORM           |
| MEAN INTER ARRIVAL TIME       | 2000 microseconds |
| DISTRIBUTION                  | UNIFORM           |
| MESSAGE LENGTH                | 16 UNITS          |
| DISTRIBUTION                  | FIXED             |
| INTERNAL MESSAGE DISTRIBUTION | UNIFORM           |
| PRIORITY CLASSES              | NONE              |
| PROTOCOL                      | HANDSHAKE         |
| HARDWARE CLASSES              | NONE              |
| LP SPEEDS                     | 100 Ki/s          |
| CP SPEEDS                     | 100 Ki/s          |
| LP MEMORY SIZES               | 10 K UNITS        |
| CP MEMORY SIZES               | 10 K UNITS        |
| LP-CP LINE SPEEDS             | 10 K/s UNITS/sec  |
| CP-CP LINE SPEEDS             | 10 K/s UNITS/sec  |
| OUTPUT QUEUE LENGTHS          | 8                 |
| BUFFER SIZE                   | 4                 |
| ROUTING                       | CFIXED            |
| SHORTEST PATHS                | LOAD BALANCED     |
| SIMULATION TIME               | 0.1 sec           |

Table 5.1    DEFAULT CONDITIONS

less than a critical maximum allowable limit. Thus, it is important to know the profile of Response Times under varying traffic conditions. Average Response Time, Maximum Response Time and Response Time distribution are typical characteristics of interest.

In this study, we concentrated on the comparison of network topologies, all operating under the same traffic conditions. The set of parameters used for these experiments, called default conditions are given in Table 5.1. As seen in the table, the message generation is assumed to be uniform with mean inter arrival time of 2000 microseconds at each node. Message inter arrival distribution is uniform. Each message is assumed to be a fixed 16 units long. When a message is generated at a node, it is destined to another node with equal probability. There are no priority classes in the messages. All nodes contain the same type of hardware. A "handshake" protocol is used for message acknowledgement.

The routing is based upon the load balanced algorithm which finds the shortest paths while trying to distribute the load evenly when there are more than one minimum length paths between the nodes [19]. Table 5.1 lists other characteristics of the node computers and interconnecting lines.

## 5.2 Experimental Results

The results of the experiments are given as a short report

together with a representation of the network topology in Appendix I (Figures 1 to 33) for each system and a summary of the main features as tables 5.2 and 5.3. In the tables the results are divided into two groups for 9 and 10 node systems and for 15 and 16 node systems. In each group the networks are ranked in increasing number of output links. The tables also list the Average Response Time and the Average Path Length (number of inter node links traversed by a transaction).

An example of a complete set of results for a 16 node 'Regular' Cross Connected network is given as Figures 3.5 to 3.7. For the majority of experiments the package default conditions were used, and these are outlined in Table 5.1. However, for the 'fixed path length' experiments the distribution of destinations was adjusted so that all transactions had a known fixed path length of 1 to 4 (Experiment 26).

The results of the experiment have also been plotted on two graphs of:

1. Average Response Time vs. Total Output Links  
(Figure 5.1)
2. Average Response Time vs. Average Path Length  
(Figure 5.2)

We find a good correlation between Response Time and Path

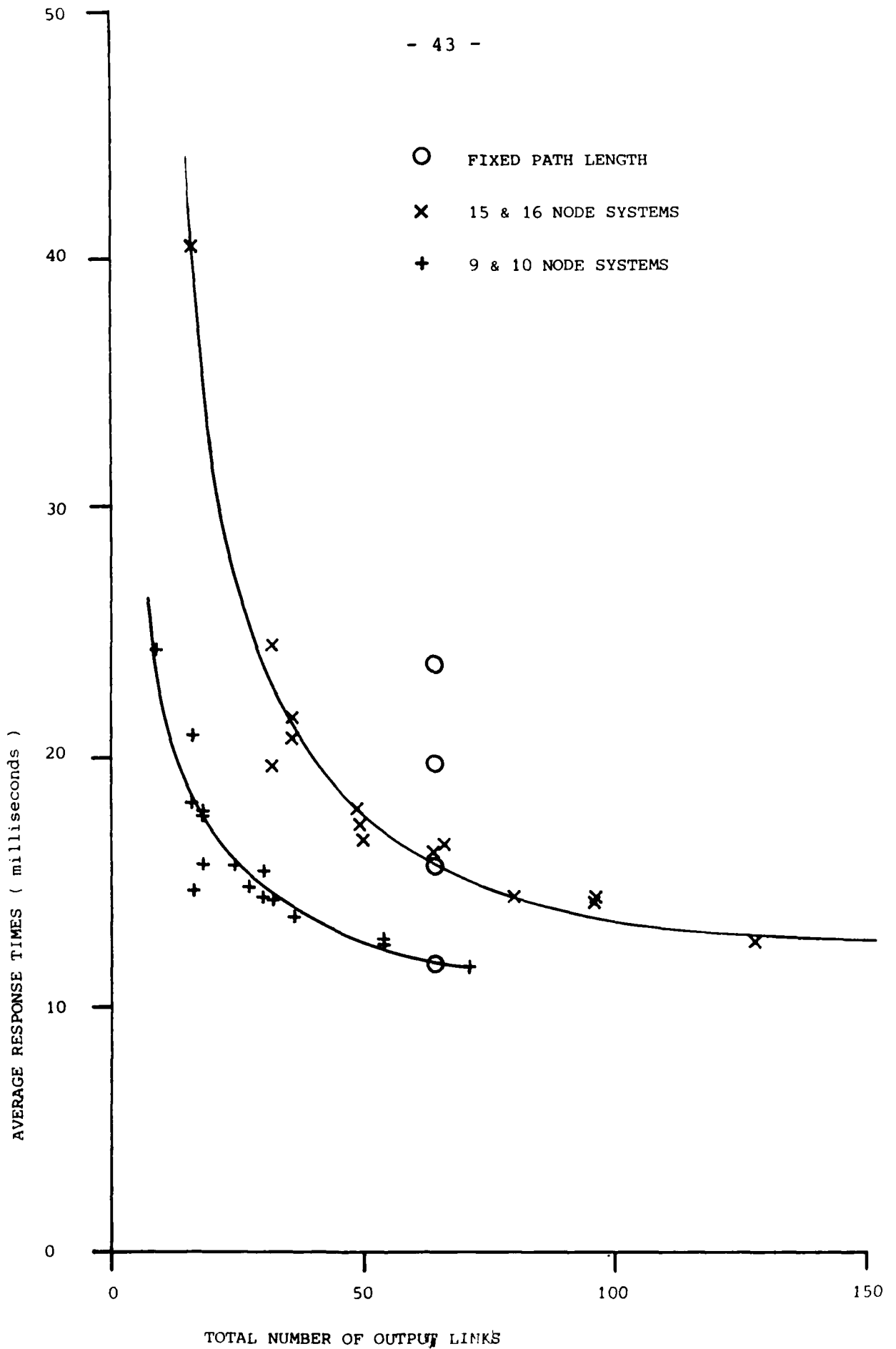

FIGURE 5.1

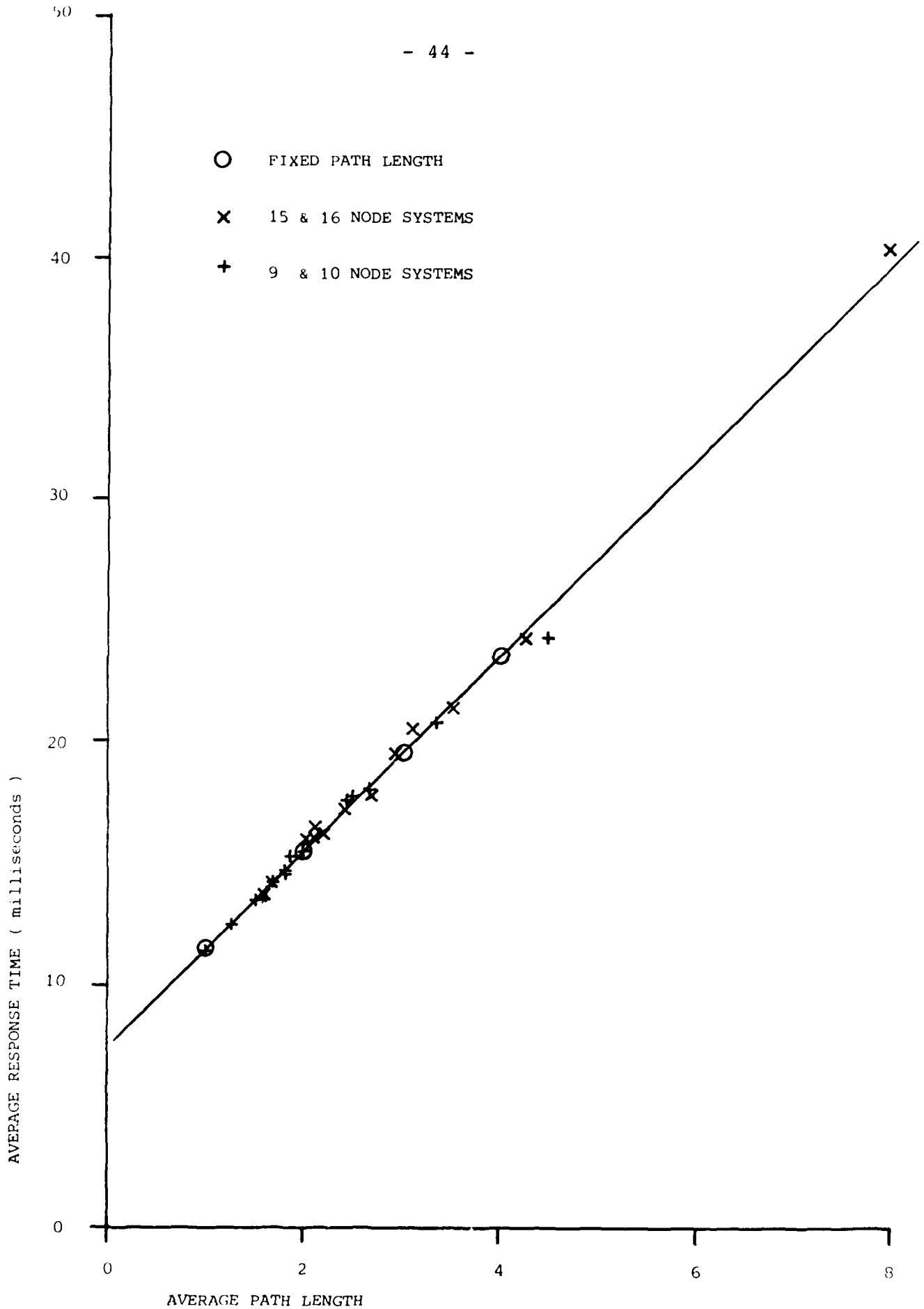

FIGURE 5.2

9 and 10 NODE NETWORKS

| NETWORK NUMBER<br>(Fig. No. in Appx. 1) | NUMBER OF NODES | TOPOLOGY                | RESPONSE TIME<br>(msec) | PATH LENGTH<br>(average) | TOTAL OUTPUT LINKS |
|---|-----------------|-------------------------|-------------------------|--------------------------|--------------------|
| 1                                       | 9               | RING UNIDIRECTIONAL     | 24.2                    | 4.50                     | 9                  |
| 2                                       | 9               | LINE                    | 20.7                    | 3.33                     | 16                 |
| 3                                       | 9               | BINARY TREE             | 18.0                    | 2.67                     | 16                 |
| 4                                       | 9               | STAR                    | 14.5                    | 1.79                     | 16                 |
| 5                                       | 9               | RING BIDIRECTIONAL      | 17.7                    | 2.50                     | 18                 |
| 6                                       | 9               | NET HEX CELLS 3 x 3     | 17.5                    | 2.47                     | 18                 |
| 7                                       | 9               | SELCHUCK                | 15.5                    | 2.00                     | 18                 |
| 8                                       | 9               | NET SQUARE CELLS        | 15.5                    | 2.00                     | 24                 |
| 9                                       | 9               | HEX CELLS REGULAR       | 14.6                    | 1.81                     | 27                 |
| 10                                      | 9               | HYPERCUBE (INCOMPLETE)  | 15.3                    | 1.83                     | 30                 |
| 11                                      | 10              | PETERSEN GRAPH          | 14.2                    | 1.67                     | 30                 |
| 12                                      | 9               | NET TRIANGULAR CELLS    | 14.1                    | 1.67                     | 32                 |
| 13                                      | 9               | CROSS CONNECTED (X CON) | 13.4                    | 1.50                     | 36                 |
| 14                                      | 9               | X CON + ALT 1st. DIAG   | 12.5                    | 1.25                     | 54                 |
| 15                                      | 9               | X CON + PARALLEL        | 12.3                    | 1.25                     | 54                 |
| 16                                      | 9               | X CON + H BONE          | 12.5                    | 1.25                     | 54                 |
| 17                                      | 9               | X CON + BOTH            | 11.4                    | 1.00                     | 72                 |

TABLE 5.2

15 and 16 NODE NETWORKS

| NETWORK<br>(Fig. No.<br>in Appx. I) | NUMBER<br>OF NODES | TOPOLOGY                | RESPONSE<br>TIME<br>(msec) | PATH<br>LENGTH<br>(average) | TOTAL OUTPUT<br>LINKS |
|-------------------------------------|--------------------|-------------------------|----------------------------|-----------------------------|-----------------------|
| 18                                  | 16                 | RING UNIDIRECTIONAL     | 40.4                       | 8.00                        | 16                    |
| 19                                  | 16                 | RING BIDIRECTIONAL      | 24.3                       | 4.23                        | 32                    |
| 20                                  | 16                 | SELCHUCK                | 19.5                       | 2.93                        | 32                    |
| 21                                  | 15                 | BINARY TREE             | 21.4                       | 3.51                        | 36                    |
| 22                                  | 16                 | NET HEX CELLS 4 x 4     | 20.5                       | 3.21                        | 36                    |
| 23                                  | 16                 | NET SQUARE CELLS        | 17.8                       | 2.67                        | 48                    |
| 24                                  | 16                 | HEX CELLS (REGULAR)     | 17.2                       | 2.40                        | 48                    |
| 25                                  | 15                 | WEB NESTED PENTAGONS    | 16.5                       | 2.11                        | 50                    |
| 26                                  | 16                 | CROSS CONNECTED (X CON) | 16.0                       | 2.13                        | 64                    |
| 26                                  | 16                 | X CON FIXED PATH LGTH   | 11.5                       | 1                           | 64                    |
| 26                                  | 16                 | X CON FIXED PATH LGTH   | 15.5                       | 2                           | 64                    |
| 26                                  | 16                 | X CON FIXED PATH LGTH   | 19.5                       | 3                           | 64                    |
| 26                                  | 16                 | X CON FIXED PATH LGTH   | 23.5                       | 4                           | 64                    |
| 27                                  | 16                 | HYPERCUBE               | 16.0                       | 2.07                        | 64                    |
| 28                                  | 16                 | NET TRIANG CELLS 4 x 4  | 16.3                       | 2.23                        | 66                    |
| 29                                  | 16                 | X CON + BOTH 2nd        | 14.2                       | 1.67                        | 80                    |
| 30                                  | 16                 | X CON + ALT 1st         | 13.9                       | 1.60                        | 96                    |
| 31                                  | 16                 | X CON + PARALLEL 1st    | 13.8                       | 1.60                        | 96                    |
| 32                                  | 16                 | X CON + H BONE 1st      | 14.1                       | 1.67                        | 96                    |
| 33                                  | 16                 | X CON + BOTH 1st        | 13.4                       | 1.47                        | 128                   |

TABLE 5.3

Length but not such good correlation between Response Time and Total Links although a general trend is evident.

### 5.3 Delay time calculations

Consider a message generated at node I whose destination is node J, and let this transfer take place via a path of length N. Then the total unavoidable delay, (i.e. ignoring queuing) can be broken down into groups:

1. Delays at Host Processor I DH(I)
2. Inter Processor Delays
  - i) Host to Communication at node I DHC(I)
  - ii) Communication to Host at node J DCH(J)
3. Communication Delays
  - i) Communication Processor at node K,  
where K is on the path from I to J  
(including I and J) DC(K)
  - ii) Communication link from node K to  
node L DL(K,L)

As we have taken default conditions where all processors and lines are identical the total delay can be simplified as:

$$\text{Total delay} = 2*DH + 2*DHC + (N+1)*DC + N*DL \quad (5.1)$$

It can be seen that the Total Delay depends on path length linearly and the shape is given by

$$DC + DL.$$

For the default conditions used the packet length is 16 units to which an overhead of another 16 units is added and the line speeds are 10K units/sec. Therefore we would expect DL to be  $32/10 \text{ msec} = 3.2 \text{ msec}$ .

As presently implemented the Communication Processor delay DC is manifested as a delay of 0.2 msec under default conditions. Thus we would expect the slope of the Response Time vs. Path Length curve to be at least 3.4 msec/unit.

The slope determined experimentally from Figure 5.2 is 4.0 msec/unit. The extra 0.6 msec/unit can be accounted as due to queuing delays.

The fixed length experiments (Experiment 26) confirm this. In each of these experiments the path length of all messages was kept constant. The four sets of results refer to four fixed path length values of 1 to 4. In these cases the average response time corresponds to the Total Delay in (5.1).

As an extension of this work a further series of experiments using different message lengths will be performed. Also a series under heavier traffic rates to investigate delays due to congestion will be undertaken.

REFERENCES

1. PAKER, Y., "Variable topology multicomputer system", Technical report, European research Office, US Army, Grant DA-ERO-124-74-50079, 1975
2. PAKER, Y., "Variable Topology Multicomputer System Evaluation, Technical Report, European Research Office, Grant DAJA 37-35-0401, 1976
3. PAKER, Y., "Control, Synchronization and Reconfigurability problems in Variable Topology Multicomputer Systems", Technical Report, European Research Office, US Army, Grant DA-ERO-78-G-110, 1980
4. SUMNEY, L.W., "VSLI with a vengeance", IEEE Spectrum, pp. 24-27, April 1980
5. PAKER, Y., Multi-Microprocessor Systems, Academic Press, 1983
6. METCALFE, R.M., BOGGS, D.R., "Ethernet: Distributed packet switching for local computer networks," Comm. of ACM, Vol.19, pp. 395-404, 1976
7. HOPPER, A., "Local Area Computer Communication Network", Ph.D Thesis, Cambridge University, Technical Report 7, April 1978
8. PAKER, Y. et al, "NPL Multicomputer Ring Modelling and Simulation", Technical Report, The Polytechnic of Central London, 1983
9. PAKER, Y., & VERJUS, J.P., Ed., Distributed Computer Systems, Academic Press, 1983
10. PAKER, Y. & BOZYIGIT, M., "Variable Topology Computer", Euromicro 1976 Proceedings, pp. 141-151, 1976.

11. DICKSON, P.A., "ARPA network will represent integration on a large scale," *Electronics*, pp.131-134, Sept.1968
12. ABRAMSON, N., "The ALOHA system - another alternative for computer communications", 1970 Fall Joint Computing Conf. AFIPS Conf. Proceedings, Vol.37, pp. 281-285, 1970
13. SCANTLEBURG, R.A. & WILKINSON, P.T., "The National Physical Laboratory data communication network", *ICCC Stockholm 1974 Proceedings* pp.223-228, 1974
14. KLEINROCK, L., *Communication Nets: Stochastic message flow and delay*, Dover Publ., Inc., N.Y., 1972
15. FULTZ, G.L. & KLEINROCK, L., "Adaptive routing techniques for store-and-forward computer communication networks", *Proceedings IEEE Int. Conf., Comm.* pp. 39.1-39.8, 1978
16. PRICE, W.L., "Simulation studies of an isarithmatically controlled store-and-forward data communication network", *Information processing 74 - North-Holland Publ. Company*, pp. 151-154, 1974
17. CEGRELL, T.M. "A routing procedure for TIDAS message switching network", *IEEE Trans. on Computing*, Vol.Comm-28, no.6, pp. 575-585, 1975
18. CANTOR, D.G. & GERLA, M., "Optimal routing in a packet switched computer network", *IEEE Trans, on Computing*, Vol. Comm-23, no.10, pp. 1062-1069, 1974
19. BOZYIGIT, M. & PAKER, Y., "A topology reconfiguration mechanism for distributed computer systems", *The Computer Journal*, Vol. 25, No. 1, pp.87-92.1982

Appendix I

Experimental Results for  
some 9 & 10 and 15 & 16 node  
Interconnection Topologies

SIMULATION DURATION (seconds) = 2.10  
 AVERAGE DELAY TIME (microseconds) = 24238.5  
 TOTAL EXTERNAL TRAFFIC = 446  
 TOTAL HOST CONTENT = 0  
 MESSAGES IN COMMUNICATION SUBSYSTEM = 21  
 MESSAGES DELIVERED = 425  
 TOTAL DELIVERED BUT UNACKNOWLEDGED = 21  
 PERCENTAGE OF UNACKNOWLEDGED = 4.7

LOCAL TRAFFIC STATISTICS IN NUMBER OF MESSAGES

| HOST ID | EXTERNAL INPUT | DELIVERED | UNACKNOWLEDGED | CURRENT CONTENT | RECEIVED MESSAGES |
|---------|----------------|-----------|----------------|-----------------|-------------------|
| 1       | 50             | 49        | 0              | 0               | 54                |
| 2       | 50             | 49        | 0              | 0               | 43                |
| 3       | 50             | 46        | 0              | 0               | 65                |
| 4       | 50             | 47        | 0              | 2               | 41                |
| 5       | 50             | 46        | 0              | 0               | 41                |
| 6       | 49             | 47        | 0              | 2               | 42                |
| 7       | 49             | 47        | 0              | 0               | 52                |
| 8       | 49             | 47        | 0              | 0               | 40                |
| 9       | 49             | 47        | 0              | 0               | 47                |
| TOTALS  | 446            | 425       | 21             | 0               | 425               |

CONNECTION TABLE

| NODE | CNTVITY | NEIGHBOURS |
|------|---------|------------|
| 1    | 1       | 2          |
| 2    | 1       | 3          |
| 3    | 1       | 4          |
| 4    | 1       | 5          |
| 5    | 1       | 6          |
| 6    | 1       | 7          |
| 7    | 1       | 8          |
| 8    | 1       | 9          |
| 9    | 1       | 1          |

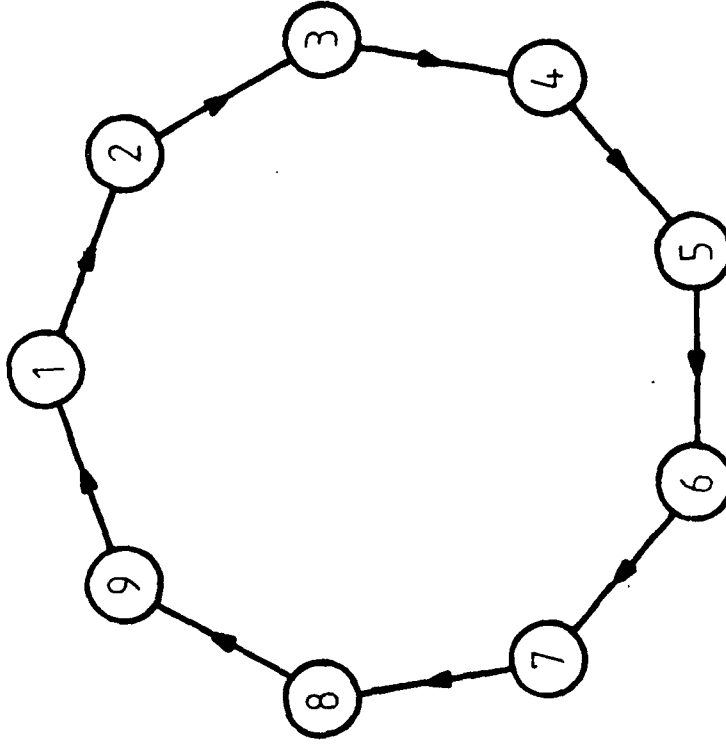

Figure 1

SIMULATION DURATION (seconds) = 0.10  
 AVERAGE DELAY TIME (microseconds) = 20722.8  
 TOTAL EXTERNAL TRAFFIC = 447  
 TOTAL HOST CONTENTS = 10  
 MESSAGES IN COMMUNICATION SUBSYSTEM = 38  
 MESSAGES DELIVERED = 399  
 TOTAL DELIVERED BUT UNACKNOWLEDGED = 0  
 PERCENTAGE OF UNACKNOWLEDGED = 0.0

MODAL TRAFFIC STATISTICS IN NUMBER OF MESSAGES

| HOST ID | EXTERNAL INPUT | DELIVERED | UNACKNOWLEDGED | CURRENT CONTENTS | RECEIVED MESSAGES IN CU |
|---------|----------------|-----------|----------------|------------------|-------------------------|
| 1       | 50             | 42        | 0              | 1                | 52                      |
| 2       | 50             | 46        | 0              | 1                | 51                      |
| 3       | 50             | 44        | 0              | 1                | 58                      |
| 4       | 50             | 45        | 0              | 1                | 38                      |
| 5       | 50             | 46        | 0              | 1                | 39                      |
| 6       | 50             | 45        | 0              | 1                | 36                      |
| 7       | 49             | 44        | 0              | 1                | 44                      |
| 8       | 49             | 46        | 0              | 1                | 38                      |
| 9       | 49             | 41        | 0              | 2                | 43                      |
| TOTALS  | 447            | 399       | 0              | 10               | 399                     |

CONNECTION TABLE

| MODE | CNTVITY | NEIGHBOURS |
|------|---------|------------|
| 1    | 1       | 2          |
| 2    | 2       | 1 3        |
| 3    | 2       | 2 4        |
| 4    | 2       | 3 5        |
| 5    | 2       | 4 6        |
| 6    | 2       | 5 7        |
| 7    | 2       | 6 8        |
| 8    | 2       | 7 9        |
| 9    | 1       | 8          |

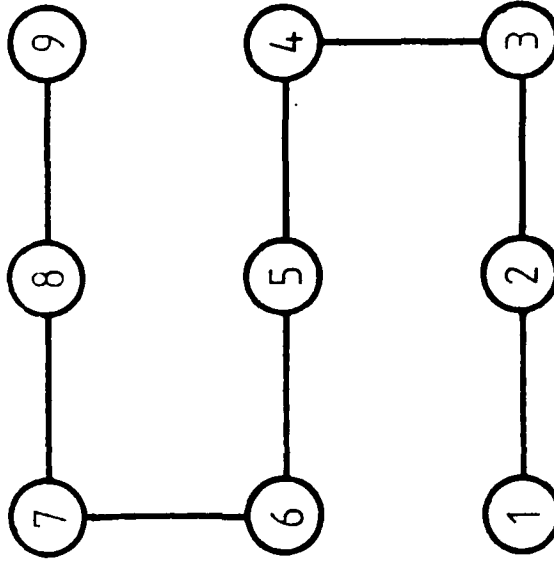

Figure 2

SIMULATION DURATION (seconds) = 0.10  
 AVERAGE DELAY TIME (microseconds) = 10012.7  
 TOTAL EXTERNAL TRAFFIC = 441  
 TOTAL HOST CONTENT = 14  
 MESSAGES IN COMMUNICATION SUBSYSTEM = 32  
 MESSAGES DELIVERED = 399  
 TOTAL DELIVERED BUT UNACKNOWLEDGED = 0  
 PERCENTAGE OF UNACKNOWLEDGED = 0.0

.....  
 NODAL TRAFFIC STATISTICS IN NUMBER OF MESSAGES  
 .....

| HOST ID | EXTERNAL INPUT | DELIVERED | UNACKNOWLEDGED | CURRENT CONTENT | RECEIVED MESSAGES |
|---------|----------------|-----------|----------------|-----------------|-------------------|
| 1       | 49             | 46        | 0              | 1               | 49                |
| 2       | 49             | 45        | 0              | 1               | 50                |
| 3       | 49             | 45        | 0              | 1               | 58                |
| 4       | 49             | 44        | 0              | 1               | 44                |
| 5       | 49             | 44        | 0              | 1               | 33                |
| 6       | 49             | 44        | 0              | 1               | 46                |
| 7       | 49             | 44        | 0              | 1               | 37                |
| 8       | 49             | 44        | 0              | 1               | 36                |
| 9       | 49             | 43        | 0              | 2               | 46                |
| TOTALS  | 441            | 399       | 0              | 10              | 399               |

.....  
 CONNECTION TABLE  
 .....

| NODE | CONNECTIVITY | NEIGHBOURS |
|------|--------------|------------|
| 1    | 2            | 2 3        |
| 2    | 3            | 1 4 5      |
| 3    | 3            | 1 6 7      |
| 4    | 3            | 2 8 9      |
| 5    | 1            | 2          |
| 6    | 1            | 3          |
| 7    | 1            | 3          |
| 8    | 1            | 4          |
| 9    | 1            | 4          |

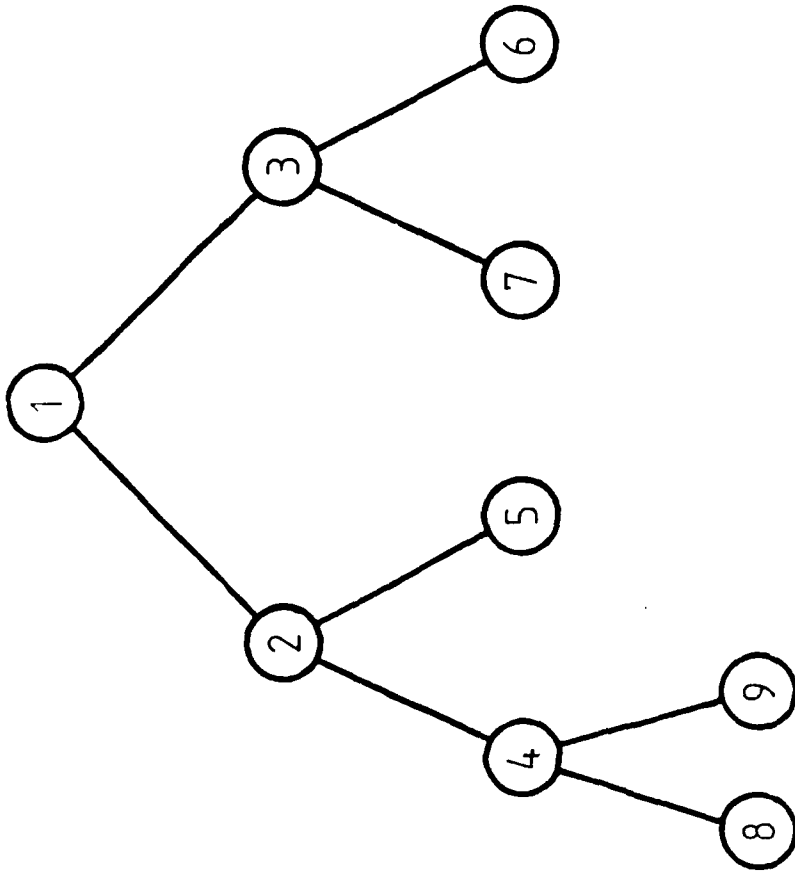

Figure 3

SIMULATION DURATION (seconds) = 0.10  
 AVERAGE DELAY TIME (microseconds) = 14510.7  
 TOTAL EXTERNAL TRAFFIC = 449  
 TOTAL HOST CONTENT = 10  
 MESSAGES IN COMMUNICATION SUBSYSTEM = 25  
 MESSAGES DELIVERED = 414  
 TOTAL DELIVERED BUT UNACKNOWLEDGED = 0  
 PERCENTAGE OF UNACKNOWLEDGED = 0.0

MODAL TRAFFIC STATISTICS IN NUMBER OF MESSAGES

| HOST ID | EXTERNL INPUT | DELL-VERED | UNACKN-OWLEDG | CURRENT CONTENT | RECEIVED MESSAGES |
|---------|---------------|------------|---------------|-----------------|-------------------|
| 1       | 50            | 47         | 0             | 1               | 49                |
| 2       | 50            | 46         | 0             | 1               | 48                |
| 3       | 50            | 46         | 0             | 1               | 55                |
| 4       | 50            | 47         | 0             | 1               | 44                |
| 5       | 50            | 46         | 0             | 1               | 36                |
| 6       | 50            | 46         | 0             | 1               | 55                |
| 7       | 50            | 46         | 0             | 1               | 39                |
| 8       | 49            | 44         | 0             | 2               | 49                |
| 9       | 50            | 46         | 0             | 1               | 48                |
| TOTALS  | 449           | 414        | 3             | 10              | 414               |

CONNECTION TABLE

| NODE | CONTIVITY | NEIGHBOURS      |
|------|-----------|-----------------|
| 1    | 8         | 2 3 4 5 6 7 8 9 |
| 2    | 1         | 1               |
| 3    | 1         | 1               |
| 4    | 1         | 1               |
| 5    | 1         | 1               |
| 6    | 1         | 1               |
| 7    | 1         | 1               |
| 8    | 1         | 1               |
| 9    | 1         | 1               |

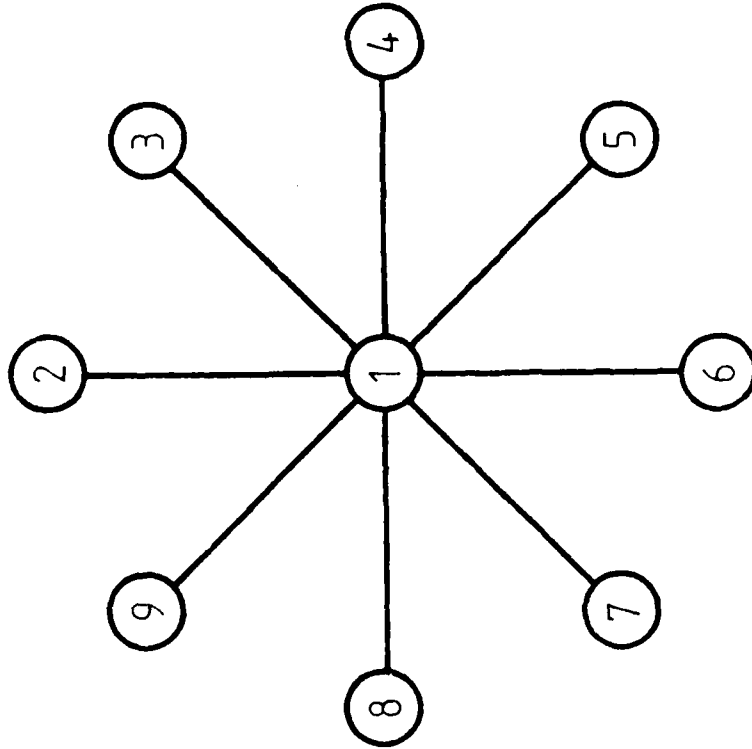

Figure 4

SIMULATION DURATION (SECONDS) = 0.10  
 AVERAGE DELAY TIME (MICROSECONDS) = 17652.4  
 TOTAL EXTERNAL TRAFFIC = 143  
 TOTAL HOST CONTENT = 10  
 MESSAGES IN COMMUNICATION SUBSYSTEM = 33  
 MESSAGES DELIVERED = 425  
 TOTAL DELIVERED BUT UNACKNOWLEDGED = 2  
 PERCENTAGE OF UNACKNOWLEDGED = 2.2

NOVAL TRAFFIC STATISTICS IN NUMBER OF MESSAGES

| HOST ID | EXTERNAL INPUT | DELIVERED | VERIFIED | UNACKNOWLEDGED | CURRENT CONTENT | RECEIVED MESSAGES | MESSAGES IN CO |
|---------|----------------|-----------|----------|----------------|-----------------|-------------------|----------------|
| 1       | 50             | 46        | 0        | 1              | 51              | 6                 | 6              |
| 2       | 50             | 45        | 0        | 1              | 45              | 5                 | 5              |
| 3       | 50             | 46        | 0        | 1              | 53              | 5                 | 5              |
| 4       | 50             | 45        | 0        | 1              | 43              | 4                 | 4              |
| 5       | 50             | 45        | 0        | 1              | 31              | 3                 | 3              |
| 6       | 50             | 45        | 0        | 1              | 49              | 2                 | 2              |
| 7       | 50             | 45        | 0        | 1              | 42              | 3                 | 3              |
| 8       | 49             | 45        | 0        | 1              | 42              | 2                 | 2              |
| 9       | 49             | 43        | 0        | 2              | 49              | 3                 | 3              |
| TOTALS  | 448            | 405       | 0        | 10             | 485             | 33                | 33             |

CONNECTION TABLE

| NODE | CONTIVITY | NEIGHBOURS |
|------|-----------|------------|
| 1    | 2         | 2 5        |
| 2    | 2         | 1 3        |
| 3    | 2         | 2 4        |
| 4    | 2         | 3 5        |
| 5    | 2         | 4 6        |
| 6    | 2         | 5 7        |
| 7    | 2         | 6 8        |
| 8    | 2         | 7 9        |
| 9    | 2         | 1 8        |

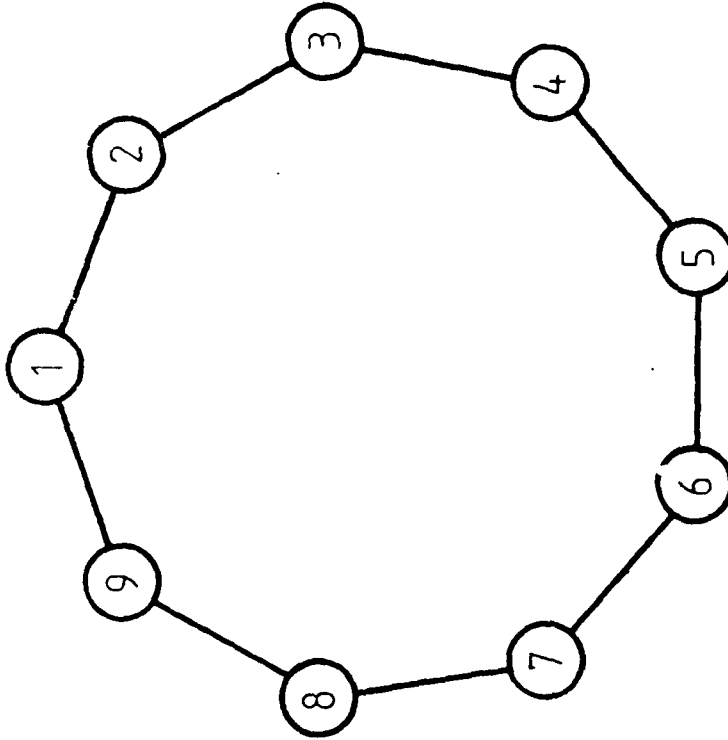

Figure 5

SIMULATION DURATION (seconds) = 0.10  
 AVERAGE DELAY TIME (microseconds) = 17467.3  
 TOTAL EXTERNAL TRAFFIC = 445  
 TOTAL HOST CONTENT = 10  
 MESSAGES IN COMMUNICATION SUBSYSTEM = 35  
 MESSAGES DELIVERED = 400  
 TOTAL DELIVERED BUT UNACKNOWLEDGED = 0  
 PERCENTAGE OF UNACKNOWLEDGED = 0.0

LOCAL TRAFFIC STATISTICS IN NUMBER OF MESSAGES

| HOST ID | EXTERNL INPUT | DELI- VERED | UNACKN- CHLEDGED | CURRENT CONTENT | RECEIVED MESSAGES |
|---------|---------------|-------------|------------------|-----------------|-------------------|
| 1       | 50            | 45          | 0                | 1               | 54                |
| 2       | 50            | 46          | 2                | 1               | 46                |
| 3       | 50            | 45          | 0                | 1               | 54                |
| 4       | 50            | 46          | 0                | 1               | 47                |
| 5       | 49            | 43          | 0                | 1               | 35                |
| 6       | 49            | 43          | 0                | 1               | 45                |
| 7       | 49            | 43          | 0                | 1               | 43                |
| 8       | 49            | 45          | 0                | 1               | 36                |
| 9       | 49            | 42          | 0                | 2               | 40                |
| TOTALS  | 445           | 400         | 0                | 10              | 400               |

CONNECTION TABLE

| NODE | ACTIVITY | NEIGHBOURS |
|------|----------|------------|
| 1    | 1        | 4          |
| 2    | 2        | 3 5        |
| 3    | 2        | 2 6        |
| 4    | 3        | 1 5 7      |
| 5    | 3        | 2 4 8      |
| 6    | 2        | 3 9        |
| 7    | 1        | 4          |
| 8    | 2        | 5 9        |
| 9    | 2        | 6 8        |

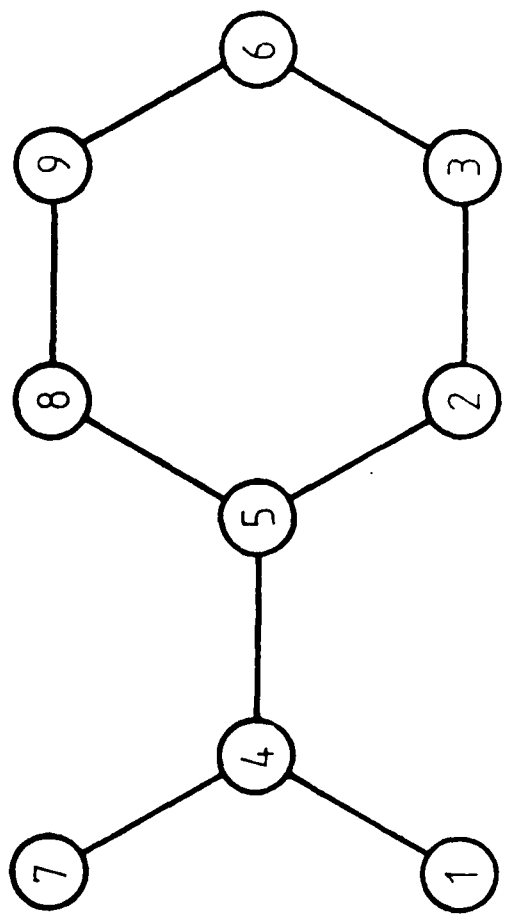

Figure 6

```

SIMULATION DURATION (seconds)      = 0.14
AVERAGE DELAY TIME (microseconds) = 15478.0
TOTAL EXTERNAL TRAFFIC             = 448
TOTAL HOST CONTENT                  = 18
MESSAGES IN COMMUNICATION SUBSYSTEM = 27
TOTAL DELIVERED BUT UNACKNOWLEDGED = 411
PERCENTAGE OF UNACKNOWLEDGED       = 91.0
    
```

LOCAL TRAFFIC STATISTICS IN NUMBER OF MESSAGES

| HOST ID | EXTERNAL INPUT | DELIVERED | UNACKNOWLEDGED | CURRENT CONTENT | RECEIVED MESSAGES |
|---------|----------------|-----------|----------------|-----------------|-------------------|
| 1       | 50             | 47        | 0              | 1               | 48                |
| 2       | 50             | 46        | 0              | 1               | 49                |
| 3       | 50             | 46        | 0              | 1               | 56                |
| 4       | 50             | 46        | 0              | 1               | 42                |
| 5       | 50             | 46        | 0              | 1               | 36                |
| 6       | 50             | 46        | 0              | 1               | 53                |
| 7       | 50             | 46        | 0              | 1               | 40                |
| 8       | 49             | 45        | 0              | 1               | 41                |
| 9       | 49             | 43        | 0              | 2               | 46                |
| TOTALS  | 448            | 411       | 0              | 10              | 411               |

CONNECTION TABLE

| NODE | CNTIVITY | NEIGHBOURS |
|------|----------|------------|
| 1    | 2        | 2 4        |
| 2    | 2        | 3 8        |
| 3    | 2        | 1 6        |
| 4    | 2        | 6 7        |
| 5    | 2        | 2 4        |
| 6    | 2        | 5 9        |
| 7    | 2        | 1 8        |
| 8    | 2        | 5 9        |
| 9    | 2        | 3 7        |

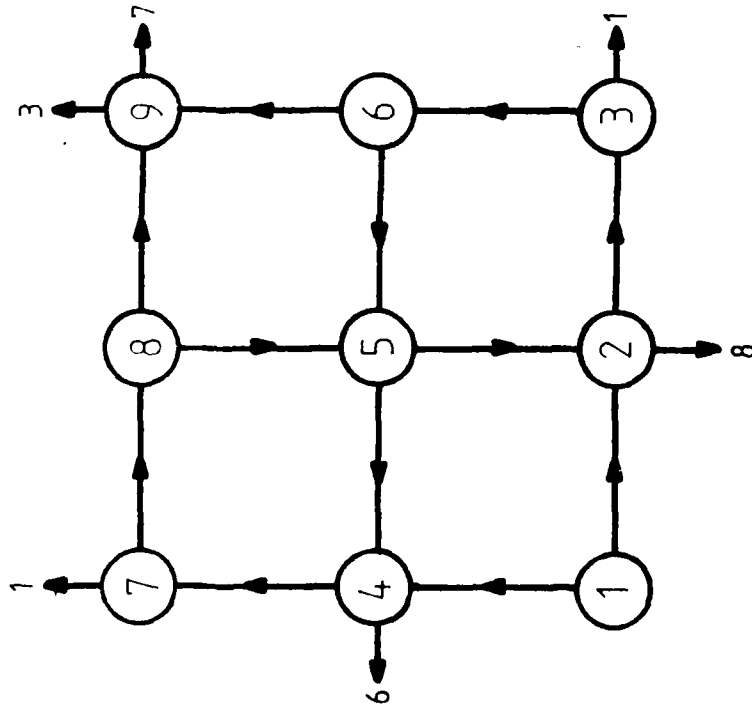

Figure 7

```

SIMULATION DURATION (SECONDS) = 0.10
AVERAGE DELAY TIME (MICROSECONDS) = 15503.6
TOTAL EXTERNAL TRAFFIC = 449
TOTAL HOST CONTENT = 10
MESSAGES IN COMMUNICATION SUBSYSTEM = 22
TOTAL DELIVERED BUT UNACKNOWLEDGED = 417
PERCENTAGE OF UNACKNOWLEDGED = 0.0
    
```

\*\*\*\*\*  
 NODAL TRAFFIC STATISTICS IN NUMBER OF MESSAGES  
 \*\*\*\*\*

| HOST ID | EXTERNAL INPUT | DELIVERED | UNACKNOWLEDGED | CURRENT CONTENT | RECEIVED MESSAGES | MESSAGES IN COMMUNICATION SUBSYSTEM |
|---------|----------------|-----------|----------------|-----------------|-------------------|-------------------------------------|
| 1       | 50             | 47        | 0              | 1               | 49                | 3                                   |
| 2       | 50             | 46        | 0              | 1               | 48                | 3                                   |
| 3       | 50             | 46        | 0              | 1               | 56                | 1                                   |
| 4       | 50             | 47        | 0              | 1               | 44                | 4                                   |
| 5       | 50             | 47        | 0              | 1               | 37                | 1                                   |
| 6       | 50             | 47        | 0              | 1               | 56                | 2                                   |
| 7       | 50             | 46        | 0              | 1               | 39                | 2                                   |
| 8       | 50             | 47        | 0              | 1               | 39                | 2                                   |
| 9       | 49             | 44        | 0              | 2               | 49                | 4                                   |
| TOTALS  | 449            | 417       | 0              | 10              | 417               | 22                                  |

\*\*\*\*\*  
 CONNECTION TABLE  
 \*\*\*\*\*

| NODE | CONTENTS | NEIGHBOURS |
|------|----------|------------|
| 1    | 2        | 2 4        |
| 2    | 3        | 1 3 5      |
| 3    | 2        | 2 6        |
| 4    | 3        | 1 5 7      |
| 5    | 4        | 2 4 6 8    |
| 6    | 3        | 3 5 9      |
| 7    | 2        | 1 6        |
| 8    | 3        | 5 7 9      |
| 9    | 2        | 6 8        |

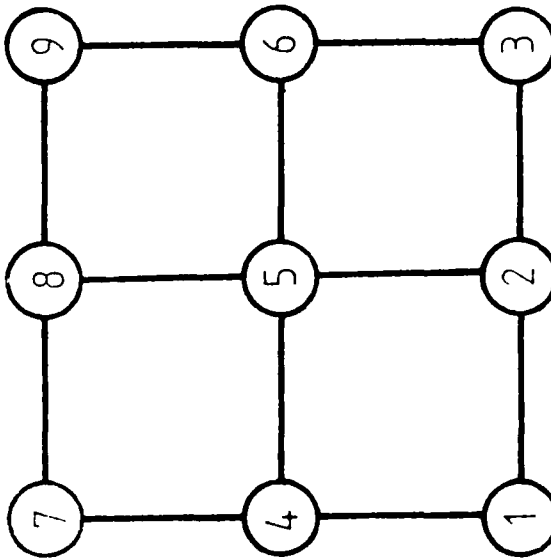

Figure 8

SIMULATION DURATION (seconds) = 2.10  
 AVERAGE DELAY TIME (microseconds) = 14637.4  
 TOTAL INTERNAL TRAFFIC = 449  
 TOTAL HOST CONTENT = 10  
 MESSAGES IN COMMUNICATION SUBSYSTEM = 20  
 MESSAGES DELIVERED = 419  
 TOTAL DELIVERED BUT UNACKNOWLEDGED = 0  
 PERCENTAGE OF UNACKNOWLEDGED = 0.0

LOCAL TRAFFIC STATISTICS IN NUMBER OF MESSAGES

| HOST ID | EXTERNAL INPUT | DELIVERED | UNACKNOWLEDGED | CURRENT CONTENT | RECEIVED MESSAGES | MESSAGES IN OUTPUT |
|---------|----------------|-----------|----------------|-----------------|-------------------|--------------------|
| 1       | 50             | 47        | 0              | 1               | 49                | 2                  |
| 2       | 50             | 46        | 0              | 1               | 49                | 2                  |
| 3       | 50             | 47        | 0              | 1               | 56                | 2                  |
| 4       | 50             | 47        | 0              | 1               | 44                | 3                  |
| 5       | 50             | 47        | 0              | 1               | 37                | 4                  |
| 6       | 50             | 47        | 0              | 1               | 56                | 2                  |
| 7       | 50             | 46        | 0              | 1               | 39                | 1                  |
| 8       | 50             | 47        | 0              | 1               | 39                | 2                  |
| 9       | 50             | 45        | 0              | 2               | 50                | 2                  |
| TOTALS  | 449            | 419       | 0              | 10              | 419               | 20                 |

CONNECTION TABLE

| NODE | CONTINITY | NEIGHBOURS |
|------|-----------|------------|
| 1    | 3         | 3 4 7      |
| 2    | 3         | 3 5 8      |
| 3    | 3         | 2 6 9      |
| 4    | 3         | 1 5 7      |
| 5    | 3         | 2 4 8      |
| 6    | 3         | 3 4 9      |
| 7    | 3         | 1 4 9      |
| 8    | 3         | 2 5 9      |
| 9    | 3         | 3 6 8      |

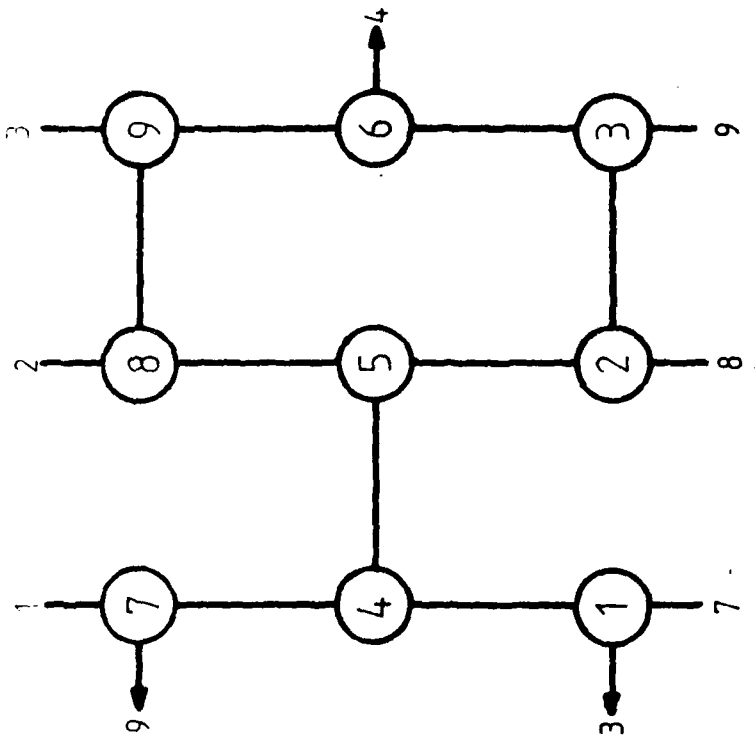

Figure 9

```

SIMULATION DURATION (seconds) = 0.10
AVERAGE DELAY TIME (microseconds) = 15255.2
TOTAL EXTERNAL TRAFFIC = 488
TOTAL HOST CONTENT = 10
MESSAGES IN COMMUNICATION SUBSYSTEM = 28
MESSAGES DELIVERED = 410
TOTAL DELIVERED BUT UNACKNOWLEDGED = 0
PERCENTAGE OF UNACKNOWLEDGED = 0.0
    
```

.....  
 NODAL TRAFFIC STATISTICS IN NUMBER OF MESSAGES  
 .....

| HOST ID | EXTERNAL INPUT | DELIVERED | UNACKNOWLEDGED | CURRENT CONTENT | RECEIVED MESSAGES | MESSAGES IN CO |
|---------|----------------|-----------|----------------|-----------------|-------------------|----------------|
| 1       | 50             | 46        | 0              | 1               | 54                | 5              |
| 2       | 50             | 46        | 0              | 1               | 45                | 4              |
| 3       | 50             | 46        | 0              | 1               | 54                | 2              |
| 4       | 50             | 46        | 0              | 1               | 44                | 2              |
| 5       | 50             | 46        | 0              | 1               | 31                | 4              |
| 6       | 50             | 45        | 0              | 1               | 50                | 1              |
| 7       | 50             | 47        | 0              | 1               | 42                | 4              |
| 8       | 49             | 44        | 0              | 1               | 42                | 3              |
| 9       | 49             | 44        | 0              | 2               | 48                | 3              |
| TOTALS  | 448            | 410       | 0              | 10              | 410               | 28             |

.....  
 CONNECTION TABLE  
 .....

| NODE | CNTIVITY | NEIGHBOURS |
|------|----------|------------|
| 1    | 4        | 2 3 5 9    |
| 2    | 3        | 1 4 6      |
| 3    | 3        | 1 4 7      |
| 4    | 3        | 2 3 8      |
| 5    | 3        | 1 6 7      |
| 6    | 3        | 2 5 8      |
| 7    | 3        | 3 5 8      |
| 8    | 3        | 4 6 7      |
| 9    | 1        | 1          |

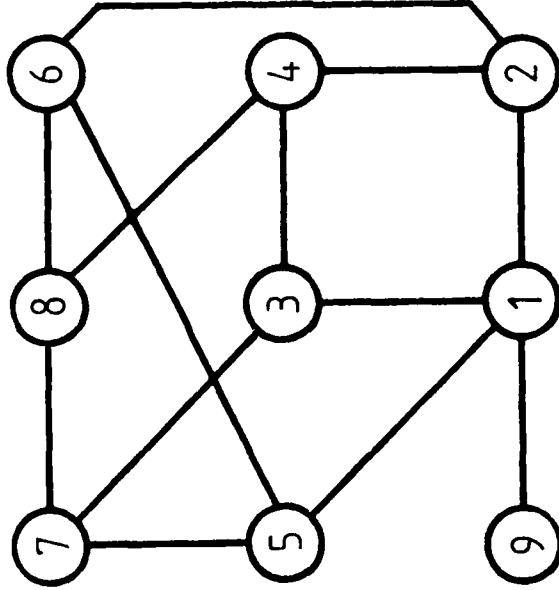

Figure 10

SIMULATION RATE (seconds) = 1.0  
 AVERAGE DELAY TIME (microseconds) = 14224.7  
 TOTAL EXTERNAL TRAFFIC = 498  
 INITIAL HOST CONTENT = 11  
 MESSAGES IN COMMUNICATION SUBSYSTEM = 28  
 MESSAGES OBTAINED = 451  
 TOTAL DELIVERED BUT UNACKNOWLEDGED = 11  
 PERCENTAGE OF UNACKNOWLEDGED = 2.2

NODAL TRAFFIC STATISTICS IN NUMBER OF MESSAGES

| HOST ID | EXTERNAL INPUT | DELIVERED | UNACKNOWLEDGED | CURRENT CONTENT | RECEIVED MESSAGES |
|---------|----------------|-----------|----------------|-----------------|-------------------|
| 1       | 49             | 46        | 0              | 1               | 57                |
| 2       | 49             | 45        | 0              | 1               | 42                |
| 3       | 49             | 43        | 0              | 1               | 57                |
| 4       | 49             | 45        | 0              | 1               | 40                |
| 5       | 49             | 49        | 0              | 1               | 48                |
| 6       | 49             | 45        | 0              | 1               | 44                |
| 7       | 49             | 45        | 0              | 1               | 44                |
| 8       | 49             | 45        | 0              | 1               | 35                |
| 9       | 49             | 45        | 0              | 1               | 42                |
| 10      | 49             | 45        | 0              | 2               | 42                |
| TOTALS  | 498            | 451       | 0              | 11              | 451               |

CONNECTION TABLE

| NODE | CONTINITY | NEIGHBOURS |
|------|-----------|------------|
| 1    | 3         | 3 4 6      |
| 2    | 3         | 4 5 7      |
| 3    | 3         | 1 2 9      |
| 4    | 3         | 1 2 3 10   |
| 5    | 3         | 1 7 10     |
| 6    | 3         | 2 6 9      |
| 7    | 3         | 3 7 9      |
| 8    | 3         | 4 8 10     |
| 9    | 3         | 4 8 10     |
| 10   | 3         | 5 6 9      |

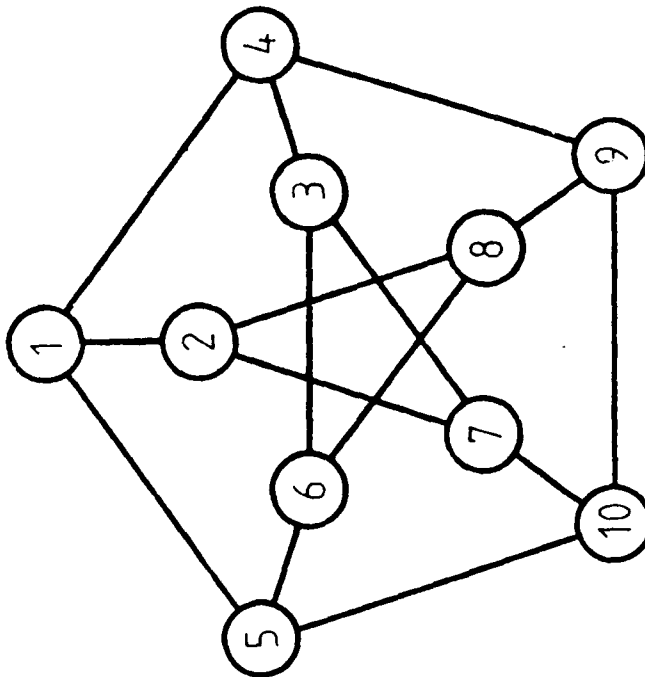

Figure 11

```

SIMULATION DURATION (seconds) = 0.10
AVERAGE DELAY TIME (microseconds) = 14110.1
TOTAL INTERNAL TRAFFIC = 449
TOTAL HOST CONTENT = 10
MESSAGES IN COMMUNICATION SUBSYSTEM = 21
MESSAGES DELIVERED = 418
TOTAL DELIVERED BUT UNACKNOWLEDGED = 0
PERCENTAGE OF UNACKNOWLEDGED = 0.0
    
```

.....  
 NODAL TRAFFIC STATISTICS IN NUMBER OF MESSAGES  
 .....

| HOST ID | EXTERNAL INPUT | DELIVERED | UNACKNOWLEDGED | CURRENT CONTENT | RECEIVED MESSAGES | MESSAGES IN CO |
|---------|----------------|-----------|----------------|-----------------|-------------------|----------------|
| 1       | 50             | 47        | 0              | 1               | 49                | 2              |
| 2       | 50             | 46        | 0              | 1               | 49                | 4              |
| 3       | 50             | 46        | 0              | 1               | 56                | 2              |
| 4       | 50             | 47        | 0              | 1               | 44                | 3              |
| 5       | 50             | 47        | 0              | 1               | 37                | 3              |
| 6       | 50             | 47        | 0              | 1               | 56                | 1              |
| 7       | 50             | 46        | 0              | 1               | 39                | 2              |
| 8       | 50             | 47        | 0              | 1               | 39                | 1              |
| 9       | 49             | 45        | 0              | 2               | 49                | 3              |
| TOTALS  | 449            | 418       | 0              | 10              | 418               | 21             |

.....  
 CONNECTION TABLE  
 .....

| NODE | ACTIVITY | NEIGHBOURS  |
|------|----------|-------------|
| 1    | 2        | 4           |
| 2    | 4        | 1 3 4 5     |
| 3    | 5        | 2 5 6       |
| 4    | 5        | 1 2 5 7 8   |
| 5    | 6        | 2 3 4 6 8 9 |
| 6    | 3        | 3 5 9       |
| 7    | 2        | 4 8         |
| 8    | 4        | 4 5 7 9     |
| 9    | 3        | 5 6         |

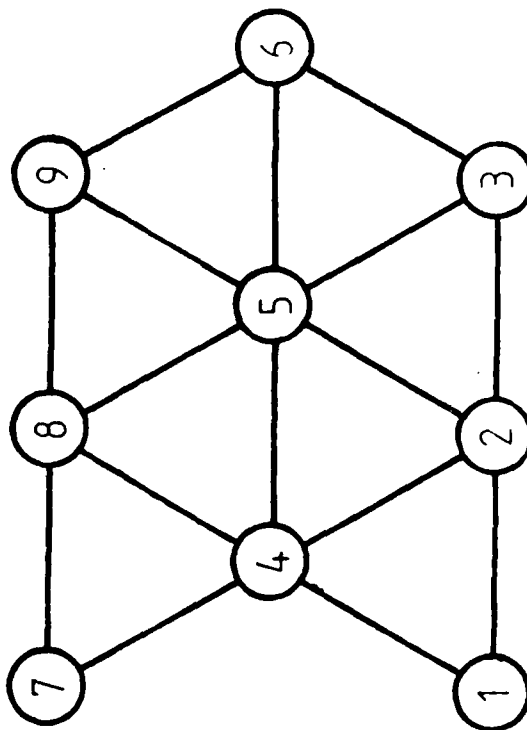

Figure 12

SIMULATION DURATION (SECONDS) = 0.10  
 AVERAGE DELAY TIME (MICROSECONDS) = 11411.4  
 TOTAL EXTERNAL TRAFFIC = 449  
 TOTAL HOST CONTENT = 10  
 MESSAGES IN COMMUNICATION SUBSYSTEM = 20  
 MESSAGES DELIVERED = 419  
 TOTAL DELIVERED BUT UNACKNOWLEDGED = 0  
 PERCENTAGE OF UNACKNOWLEDGED = 0.0

LOCAL TRAFFIC STATISTICS IN NUMBER OF MESSAGES

| HOST ID | EXTERNAL INPUT | DELIVERED | UNACKNOWLEDGED | CURRENT CONTENT | RECEIVED MESSAGES |
|---------|----------------|-----------|----------------|-----------------|-------------------|
| 1       | 50             | 47        | 0              | 1               | 49                |
| 2       | 50             | 46        | 0              | 1               | 49                |
| 3       | 50             | 47        | 0              | 1               | 56                |
| 4       | 50             | 47        | 0              | 1               | 44                |
| 5       | 50             | 47        | 0              | 1               | 37                |
| 6       | 50             | 47        | 0              | 1               | 56                |
| 7       | 50             | 46        | 0              | 1               | 39                |
| 8       | 50             | 47        | 0              | 1               | 39                |
| 9       | 49             | 45        | 0              | 2               | 50                |
| TOTALS  | 449            | 419       | 0              | 10              | 419               |

CONNECTION TABLE

| NODE | CNTIVITY | NEIGHBOURS |
|------|----------|------------|
| 1    | 4        | 2 3 4 7    |
| 2    | 4        | 1 3 5 8    |
| 3    | 4        | 1 2 6 9    |
| 4    | 4        | 1 3 6 7    |
| 5    | 4        | 2 4 6 8    |
| 6    | 4        | 3 4 5 9    |
| 7    | 4        | 1 4 8 9    |
| 8    | 4        | 2 5 7 9    |
| 9    | 4        | 3 6 7 8    |

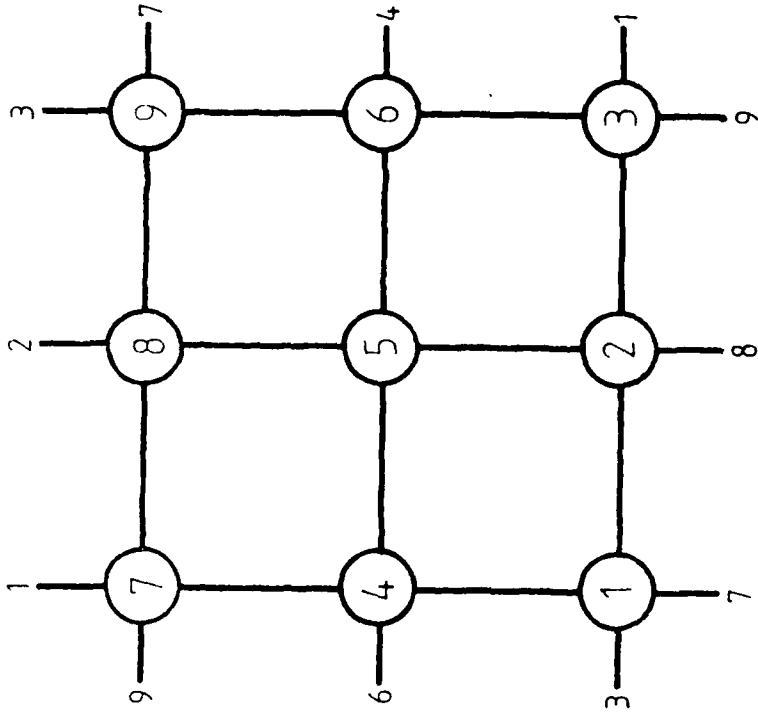

Figure 13

```

SIMULATION DURATION (seconds) = 0.14
AVERAGE DELAY TIME (microseconds) = 12499.5
TOTAL EXTERNAL TRAFFIC = 449
TOTAL HOST CONTENT = 18
MESSAGES IN COMMUNICATION SUBSYSTEM = 20
MESSAGEFS DELIVERED = 419
TOTAL DELIVERED BUT UNACKNOWLEDGED = 0
PERCENTAGE OF UNACKNOWLEDGED = 0.0
    
```

.....  
 NODAL TRAFFIC STATISTICS IN NUMBER OF MESSAGES  
 .....

| HOST ID | EXTERNAL INPUT | DELIVERED | UNACKNOWLEDGED | CURRENT CONTENT | RECEIVED MESSAGES |
|---------|----------------|-----------|----------------|-----------------|-------------------|
| 1       | 50             | 47        | 0              | 1               | 49                |
| 2       | 50             | 46        | 0              | 1               | 49                |
| 3       | 50             | 47        | 0              | 1               | 56                |
| 4       | 50             | 47        | 0              | 1               | 44                |
| 5       | 50             | 47        | 0              | 1               | 37                |
| 6       | 50             | 47        | 0              | 1               | 56                |
| 7       | 50             | 46        | 0              | 1               | 39                |
| 8       | 50             | 47        | 0              | 1               | 39                |
| 9       | 49             | 45        | 0              | 2               | 50                |
| TOTALS  | 449            | 419       | 0              | 18              | 419               |

.....  
 CONNECTION TABLE  
 .....

| NODE | ENTITTY | NEIGHBOURS  |
|------|---------|-------------|
| 1    | 6       | 2 3 4 5 7 9 |
| 2    | 6       | 1 3 4 5 8 9 |
| 3    | 6       | 1 2 4 6 8 9 |
| 4    | 6       | 1 2 5 6 7 9 |
| 5    | 6       | 1 2 4 6 8 9 |
| 6    | 6       | 1 3 4 5 8 9 |
| 7    | 6       | 1 2 4 6 8 9 |
| 8    | 6       | 1 2 5 6 7 9 |
| 9    | 6       | 1 3 5 6 7 8 |

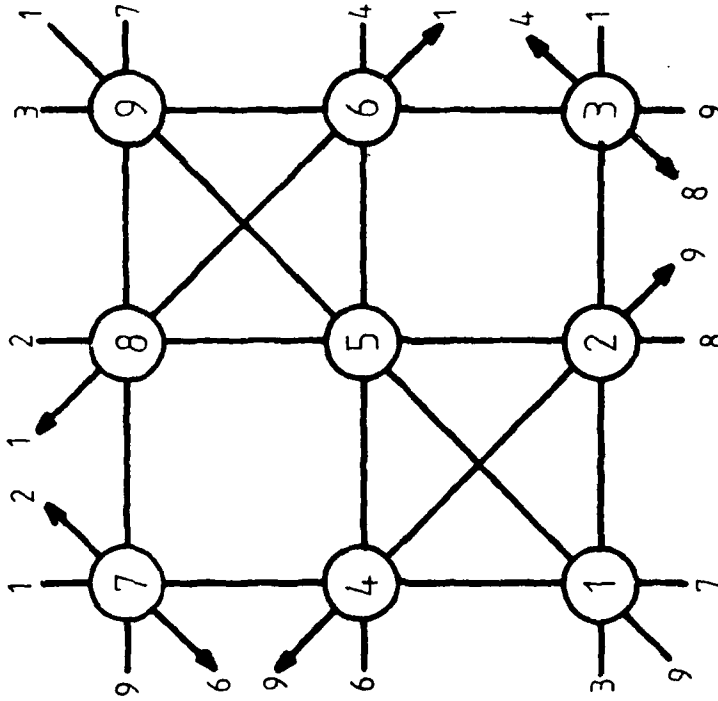

Figure 14

SIMULATION DURATION (seconds) = 0.14  
 AVERAGE RELAY TIME (microseconds) = 12321.5  
 TOTAL EXTERNAL TRAFFIC = 440  
 TOTAL HOST CONTENT = 10  
 MESSAGES IN COMMUNICATION SUBSYSTEM = 19  
 MESSAGES DELIVERED = 420  
 TOTAL DELIVERED BUT UNACKNOWLEDGED = 0  
 PERCENTAGE OF UNACKNOWLEDGED = 0.0

LOCAL TRAFFIC STATISTICS IN NUMBER OF MESSAGES

| HOST ID | EXTERNAL INPUT | DELIVERED | UNACKNOWLEDGED | CURRENT CONTENT | RECEIVED MESSAGES | MESSAGES IN CO |
|---------|----------------|-----------|----------------|-----------------|-------------------|----------------|
| 1       | 50             | 47        | 0              | 1               | 49                | 4              |
| 2       | 50             | 46        | 0              | 1               | 49                | 3              |
| 3       | 50             | 47        | 0              | 1               | 57                | 2              |
| 4       | 50             | 47        | 0              | 1               | 44                | 1              |
| 5       | 50             | 47        | 0              | 1               | 37                | 2              |
| 6       | 50             | 47        | 0              | 1               | 56                | 1              |
| 7       | 50             | 47        | 0              | 1               | 33                | 2              |
| 8       | 50             | 47        | 0              | 1               | 39                | 3              |
| 9       | 49             | 45        | 0              | 2               | 50                | 1              |
| TOTALS  | 449            | 423       | 0              | 10              | 420               | 19             |

CONNECTION TABLE

| MODE | CNTIVITY | NEIGHBOURS  |
|------|----------|-------------|
| 1    | 6        | 2 3 4 6 7 8 |
| 2    | 6        | 1 3 4 5 8 9 |
| 3    | 6        | 1 2 5 6 7 9 |
| 4    | 6        | 1 2 3 6 7 8 |
| 5    | 6        | 2 3 4 6 7 8 |
| 6    | 6        | 1 3 4 5 8 9 |
| 7    | 6        | 1 3 4 5 8 9 |
| 8    | 6        | 1 2 5 6 7 9 |
| 9    | 6        | 2 3 4 6 7 8 |

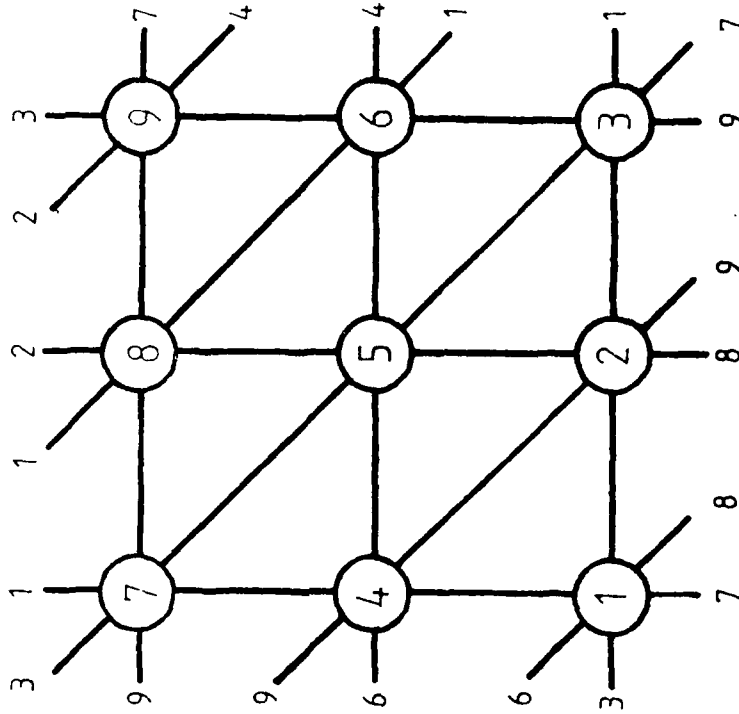

Figure 15

SIMULATION DURATION (seconds) = 2.10  
 AVERAGE DELAY TIME (microseconds) = 12484.5  
 TOTAL EXTERNAL TRAFFIC = 449  
 TOTAL HOST CONTENT = 10  
 MESSAGES IN COMMUNICATION SUBSYSTEM = 20  
 MESSAGES DELIVERED = 419  
 TOTAL DELIVERED BUT UNACKNOWLEDGED = 0  
 PERCENTAGE OF UNACKNOWLEDGED = 0.0

\*\*\*\*\*  
 NODAL TRAFFIC STATISTICS (N: NUMBER OF MESSAGES)  
 \*\*\*\*\*

| HOST ID | EXTERNAL INPUT | DELIVERED | VERIFIED | UNACKNOWLEDGED | CURRENT CONTENT | RECEIVED MESSAGES | MESSAGES IN CQ |
|---------|----------------|-----------|----------|----------------|-----------------|-------------------|----------------|
| 1       | 50             | 47        | 0        | 1              | 49              | 3                 | 2              |
| 2       | 50             | 46        | 0        | 1              | 49              | 2                 | 3              |
| 3       | 50             | 47        | 0        | 1              | 56              | 3                 | 1              |
| 4       | 50             | 47        | 0        | 1              | 44              | 2                 | 1              |
| 5       | 50             | 47        | 0        | 1              | 37              | 2                 | 2              |
| 6       | 50             | 47        | 0        | 1              | 56              | 1                 | 1              |
| 7       | 50             | 46        | 0        | 1              | 39              | 3                 | 3              |
| 8       | 50             | 47        | 0        | 1              | 39              | 3                 | 3              |
| 9       | 49             | 45        | 0        | 2              | 50              | 2                 | 2              |
| TOTALS  | 449            | 419       | 0        | 10             | 419             | 20                | 20             |

\*\*\*\*\*  
 CONNECTION TABLE  
 \*\*\*\*\*

| NODE | CONTINITY | NEIGHBOURS  |
|------|-----------|-------------|
| 1    | 0         | 2 3 4 5 7 8 |
| 2    | 0         | 1 3 5 6 8 9 |
| 3    | 0         | 1 2 4 6 7 9 |
| 4    | 0         | 1 3 5 6 7 9 |
| 5    | 0         | 1 2 4 6 7 8 |
| 6    | 0         | 2 3 4 5 8 9 |
| 7    | 0         | 1 2 4 5 8 9 |
| 8    | 0         | 2 3 5 6 7 9 |
| 9    | 0         | 1 3 4 6 7 8 |

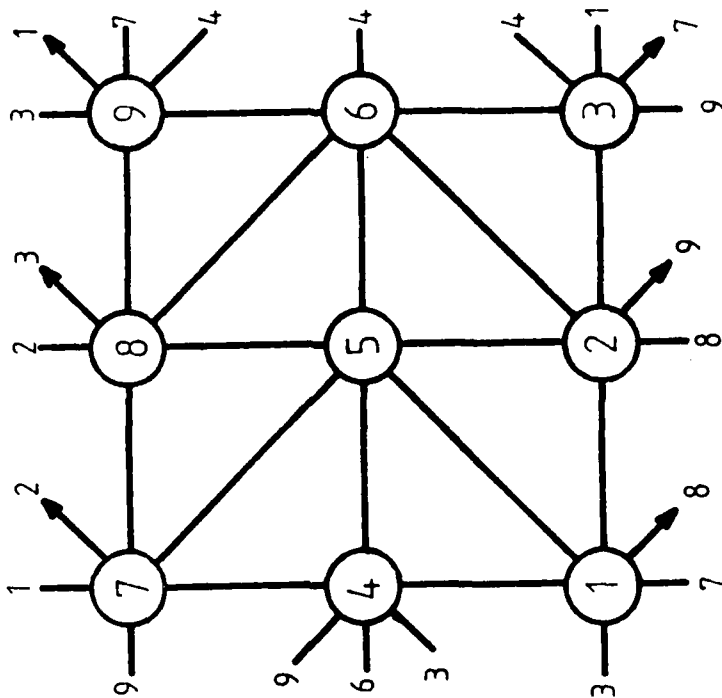

CONNECTION DELAY (seconds) = 0.10  
 AVERAGE DELAY TIME (MICROSECONDS) = 11427.6  
 TOTAL INTERNAL TRAFFIC = 449  
 TOTAL HOST CONTENT = 16  
 MESSAGES IN COMMUNICATION SUBSYSTEM = 18  
 TOTAL DELIVERED BUT UNACKNOWLEDGED = 421  
 PERCENTAGE OF UNACKNOWLEDGED = 0.0

GLOBAL TRAFFIC STATISTICS IN NUMBER OF MESSAGES

| HOST ID | EXTRNL INPUT | DELI- VEREC | UNACKN- OUNEGED | CURRENT CONTENT | RECIEVD MESSGS IN OO |
|---------|--------------|-------------|-----------------|-----------------|----------------------|
| 1       | 50           | 47          | 0               | 1               | 49                   |
| 2       | 50           | 47          | 0               | 1               | 49                   |
| 3       | 50           | 47          | 0               | 1               | 57                   |
| 4       | 50           | 47          | 0               | 1               | 44                   |
| 5       | 50           | 47          | 0               | 1               | 37                   |
| 6       | 50           | 47          | 0               | 1               | 56                   |
| 7       | 50           | 47          | 0               | 1               | 40                   |
| 8       | 50           | 47          | 0               | 1               | 39                   |
| 9       | 49           | 45          | 0               | 2               | 50                   |
| TOTALS  | 441          | 421         | 0               | 10              | 421                  |

CONNECTION TABLE

| NODE | CONTIVTY | NEIGHBOURS      |
|------|----------|-----------------|
| 1    | 8        | 2 3 4 5 6 7 8 9 |
| 2    | 8        | 1 3 4 5 6 7 8 9 |
| 3    | 8        | 1 2 4 5 6 7 8 9 |
| 4    | 8        | 1 2 3 5 6 7 8 9 |
| 5    | 8        | 1 2 3 4 6 7 8 9 |
| 6    | 8        | 1 2 3 4 5 7 8 9 |
| 7    | 8        | 1 2 3 4 5 6 8 9 |
| 8    | 8        | 1 2 3 4 5 6 7 9 |
| 9    | 8        | 1 2 3 4 5 6 7 8 |

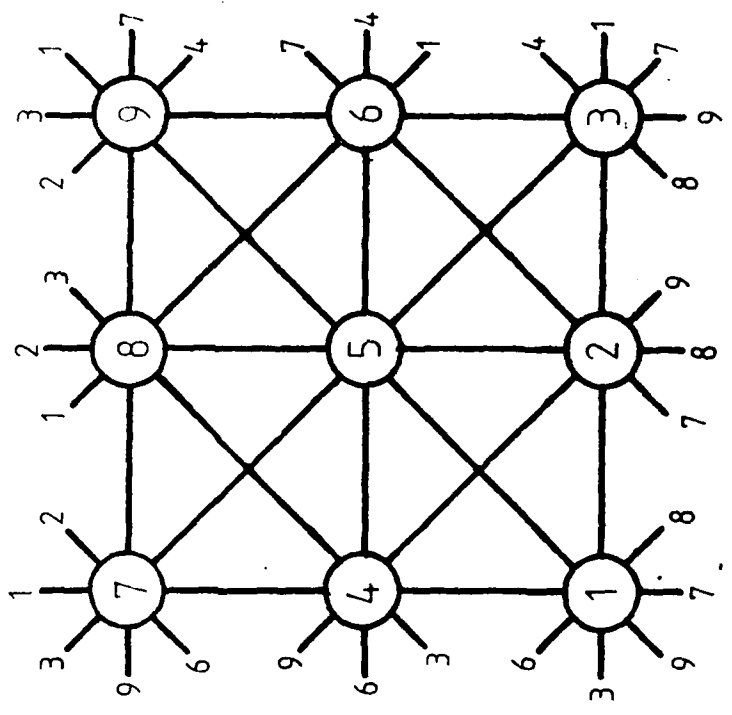

Figure 17

SIMULATION DURATION (seconds) = 5.10  
 AVERAGE DELAY TIME (microseconds) = 42403.6  
 TOTAL EXTERNAL TRAFFIC = 702  
 TOTAL HOST CONTENT = 1  
 MESSAGES IN COMMUNICATION SUBSYSTEM = 70  
 MESSAGES DELIVERED = 711  
 TOTAL DELIVERED BUT UNACKNOWLEDGED = 0  
 PERCENTAGE OF UNACKNOWLEDGED = 0.0

MODAL TRAFFIC STATISTICS IN NUMBER OF MESSAGES

| HOST ID | EXTERNAL INPUT | DELIVERED | UNACKNOWLEDGED | CURRENT CONTENT | RECEIVED MESSAGES IN CO |
|---------|----------------|-----------|----------------|-----------------|-------------------------|
| 1       | 50             | 40        | 0              | 0               | 50                      |
| 2       | 50             | 45        | 0              | 0               | 55                      |
| 3       | 49             | 44        | 0              | 0               | 46                      |
| 4       | 49             | 43        | 0              | 0               | 54                      |
| 5       | 45             | 44        | 0              | 1               | 42                      |
| 6       | 49             | 46        | 0              | 0               | 49                      |
| 7       | 49             | 46        | 0              | 0               | 42                      |
| 8       | 49             | 44        | 0              | 0               | 38                      |
| 9       | 49             | 46        | 0              | 0               | 46                      |
| 10      | 49             | 44        | 0              | 0               | 45                      |
| 11      | 49             | 43        | 0              | 0               | 40                      |
| 12      | 49             | 45        | 0              | 0               | 38                      |
| 13      | 49             | 43        | 0              | 0               | 36                      |
| 14      | 49             | 44        | 0              | 0               | 39                      |
| 15      | 49             | 44        | 0              | 0               | 39                      |
| 16      | 49             | 44        | 0              | 0               | 44                      |
| TOTALS  | 782            | 711       | 0              | 1               | 711                     |

CONNECTION TABLE

| NODE | CNTVITY | NEIGHBOURS |
|------|---------|------------|
| 1    | 1       | 2          |
| 2    | 1       | 3          |
| 3    | 1       | 4          |
| 4    | 1       | 5          |
| 5    | 1       | 6          |
| 6    | 1       | 7          |
| 7    | 1       | 8          |
| 8    | 1       | 9          |
| 9    | 1       | 10         |
| 10   | 1       | 11         |
| 11   | 1       | 12         |
| 12   | 1       | 13         |
| 13   | 1       | 14         |
| 14   | 1       | 15         |
| 15   | 1       | 16         |
| 16   | 1       | 1          |

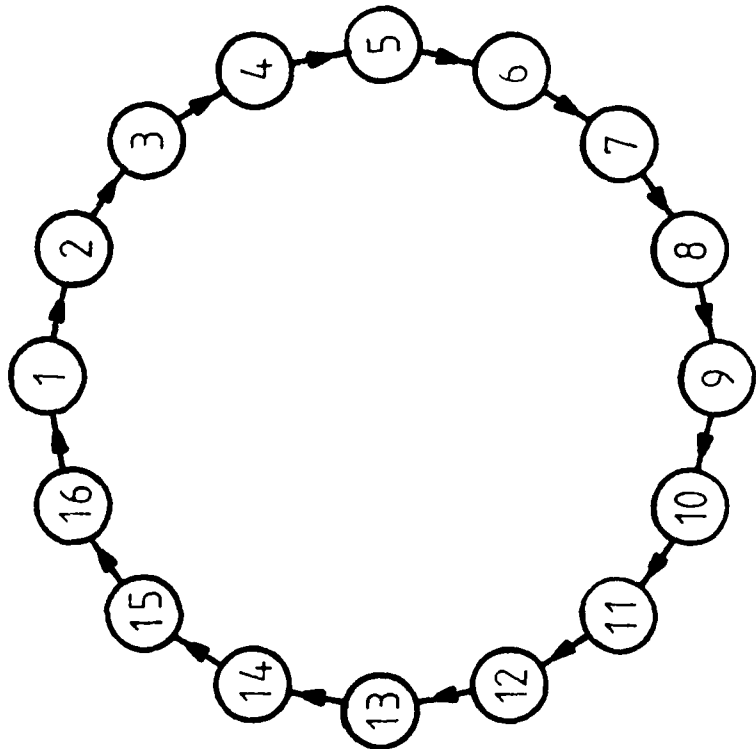

SIMULATION DURATION (seconds) = 0.10  
 AVERAGE DELAY TIME (microseconds) = 24277.1  
 TOTAL EXTERNAL TRAFFIC = 790  
 TOTAL HOST CONTENT = 13  
 MESSAGES IN COMMUNICATION SUBSYSTEM = 21  
 MESSAGES DELIVERED = 764  
 TOTAL DELIVERED BUT UNACKNOWLEDGED = 0  
 PERCENTAGE OF UNACKNOWLEDGED = 0.0

MODAL TRAFFIC STATISTICS IN NUMBER OF MESSAGES

| HOST ID | EXTERNAL INPUT | DELIVERED | UNACKNOWLEDGED | CURRENT CONTENT | RECEIVED MESSAGES |
|---------|----------------|-----------|----------------|-----------------|-------------------|
| 1       | 50             | 49        | 0              | 0               | 50                |
| 2       | 50             | 48        | 0              | 1               | 53                |
| 3       | 50             | 48        | 0              | 1               | 45                |
| 4       | 50             | 48        | 0              | 1               | 63                |
| 5       | 50             | 47        | 0              | 1               | 41                |
| 6       | 50             | 47        | 0              | 1               | 44                |
| 7       | 50             | 47        | 0              | 1               | 59                |
| 8       | 50             | 47        | 0              | 1               | 45                |
| 9       | 50             | 48        | 0              | 1               | 51                |
| 10      | 50             | 47        | 0              | 1               | 42                |
| 11      | 50             | 49        | 0              | 1               | 52                |
| 12      | 50             | 49        | 0              | 1               | 40                |
| 13      | 50             | 48        | 0              | 1               | 52                |
| 14      | 50             | 47        | 0              | 1               | 34                |
| 15      | 49             | 48        | 0              | 0               | 37                |
| 16      | 49             | 47        | 0              | 0               | 48                |
| TOTALS  | 790            | 764       | 0              | 13              | 764               |

CONNECTION TABLE

| MODE | ACTIVITY | NEIGHBOURS |
|------|----------|------------|
| 1    | 2        | 16         |
| 2    | 1        | 3          |
| 3    | 2        | 4          |
| 4    | 2        | 5          |
| 5    | 2        | 6          |
| 6    | 2        | 7          |
| 7    | 2        | 8          |
| 8    | 2        | 9          |
| 9    | 2        | 10         |
| 10   | 2        | 11         |
| 11   | 2        | 12         |
| 12   | 2        | 13         |
| 13   | 2        | 14         |
| 14   | 2        | 15         |
| 15   | 2        | 16         |
| 16   | 2        | 1          |

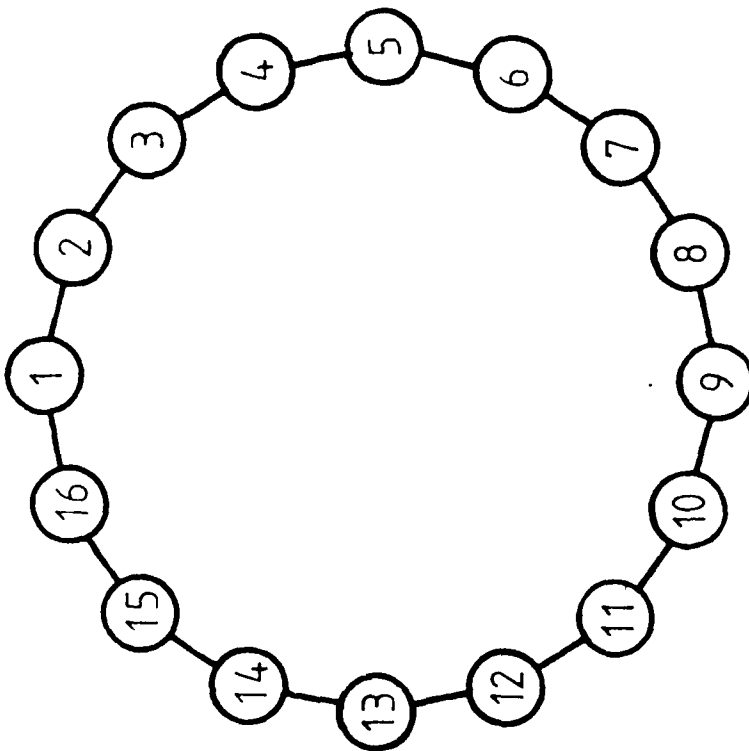

Figure 19

SIMULATION DURATION (seconds) = 0.14  
 AVERAGE DELAY TIME (microseconds) = 19455.9  
 TOTAL EXTERNAL INAFFIC = 789  
 TOTAL HOST CONTENT = 0  
 MESSAGES IN COMMUNICATION SUBSYSTEM = 11  
 MESSAGES DELIVERED = 775  
 TOTAL DELIVERED BUT UNACKNOWLEDGED = 0  
 PERCENTAGE OF UNACKNOWLEDGED = 0.0

.....  
 NODAL TRAFFIC STATISTICS IN NUMBER OF MESSAGES  
 .....

| HOST ID | EXTERNAL INPUT | DELIVERED | UNACKNOWLEDGED | CURRENT CONTENT | RECEIVED MESSAGES | MESSAGES IN QUEUE |
|---------|----------------|-----------|----------------|-----------------|-------------------|-------------------|
| 1       | 50             | 49        | 0              | 0               | 51                | 2                 |
| 2       | 50             | 49        | 0              | 0               | 54                | 0                 |
| 3       | 50             | 49        | 0              | 0               | 46                | 1                 |
| 4       | 50             | 49        | 0              | 0               | 68                | 0                 |
| 5       | 50             | 49        | 0              | 0               | 54                | 0                 |
| 6       | 49             | 48        | 0              | 0               | 45                | 0                 |
| 7       | 49             | 49        | 0              | 0               | 50                | 1                 |
| 8       | 49             | 48        | 0              | 0               | 37                | 0                 |
| 9       | 49             | 49        | 0              | 0               | 41                | 0                 |
| 10      | 49             | 49        | 0              | 0               | 49                | 1                 |
| 11      | 49             | 49        | 0              | 0               | 50                | 0                 |
| 12      | 49             | 49        | 0              | 0               | 48                | 1                 |
| 13      | 49             | 48        | 0              | 0               | 49                | 1                 |
| 14      | 49             | 48        | 0              | 0               | 32                | 0                 |
| 15      | 49             | 48        | 0              | 0               | 49                | 2                 |
| 16      | 49             | 48        | 0              | 0               | 52                | 4                 |
| TOTALS  | 789            | 775       | 0              | 0               | 775               | 14                |

.....  
 CONNECTION TABLE  
 .....

| NODE | ACTIVITY | NEIGHBOURS |
|------|----------|------------|
| 1    | 2        | 5          |
| 2    | 2        | 3 14       |
| 3    | 2        | 4 7        |
| 4    | 2        | 1 16       |
| 5    | 2        | 8 9        |
| 6    | 2        | 2 5        |
| 7    | 2        | 6 11       |
| 8    | 2        | 4 7        |
| 9    | 2        | 10 13      |
| 10   | 2        | 6 11       |
| 11   | 2        | 12 15      |
| 12   | 2        | 8 9        |
| 13   | 2        | 1 16       |
| 14   | 2        | 10 13      |
| 15   | 2        | 3 14       |
| 16   | 2        | 12 15      |

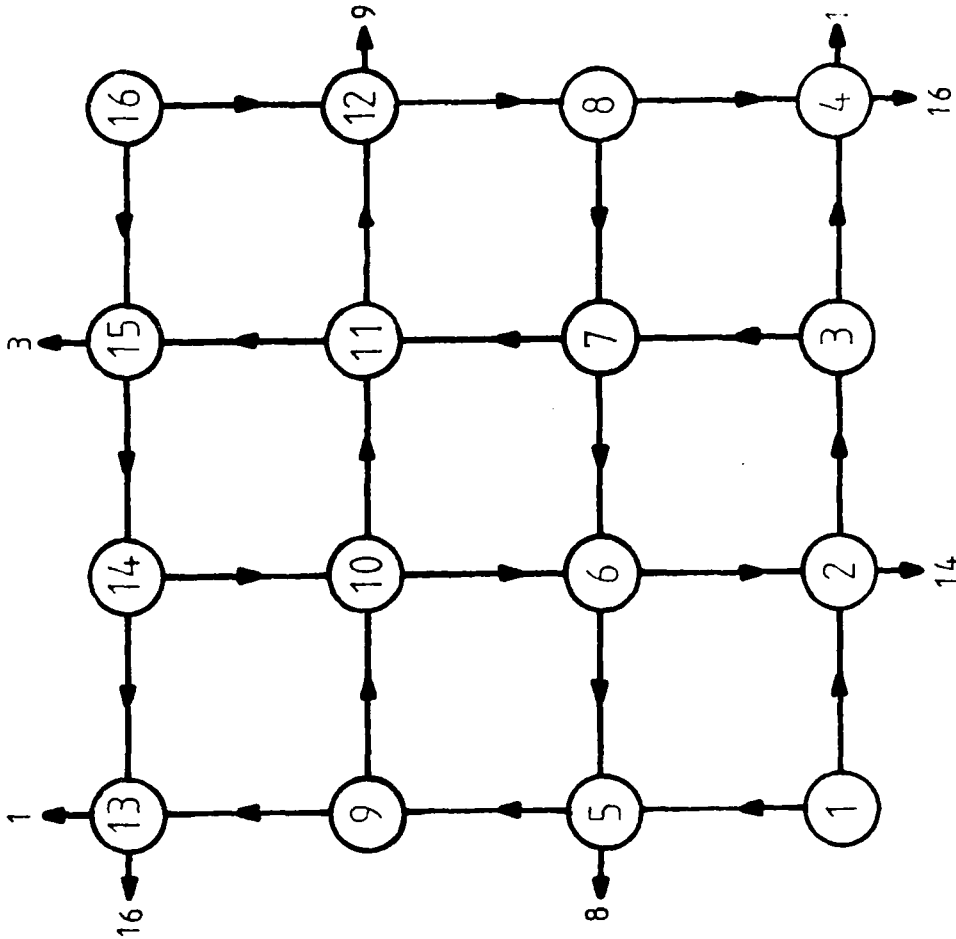

Figure 20

SIMULATION DURATION (seconds) = 6.14  
 AVERAGE DELAY TIME (microseconds) = 21351.6  
 TOTAL EXTERNAL TRAFFIC = 743  
 TOTAL HOST CONTENT = 1  
 MESSAGES IN COMMUNICATION SUBSYSTEM = 30  
 MESSAGES DELIVERED = 712  
 TOTAL DELIVERED BUT UNACKNOWLEDGED = 0  
 PERCENTAGE OF UNACKNOWLEDGED = 6.8

MODAL TRAFFIC STATISTICS IN NUMBER OF MESSAGES

| HOST ID | EXTERNAL INPUT | DELIVERED | UNACKNOWLEDGED | CURRENT CONTENT | RECEIVED MESSAGES |
|---------|----------------|-----------|----------------|-----------------|-------------------|
| 1       | 50             | 48        | 0              | 1               | 60                |
| 2       | 50             | 48        | 0              | 0               | 51                |
| 3       | 50             | 48        | 0              | 0               | 54                |
| 4       | 50             | 48        | 0              | 0               | 53                |
| 5       | 50             | 47        | 0              | 0               | 49                |
| 6       | 50             | 47        | 0              | 0               | 42                |
| 7       | 50             | 48        | 0              | 0               | 50                |
| 8       | 50             | 47        | 0              | 0               | 43                |
| 9       | 49             | 47        | 0              | 0               | 51                |
| 10      | 49             | 47        | 0              | 0               | 46                |
| 11      | 49             | 48        | 0              | 0               | 41                |
| 12      | 49             | 47        | 0              | 0               | 37                |
| 13      | 49             | 47        | 0              | 0               | 47                |
| 14      | 49             | 48        | 0              | 0               | 45                |
| 15      | 49             | 48        | 0              | 0               | 45                |
| TOTALS  | 743            | 712       | 0              | 1               | 712               |

CONNECTION TABLE

| NODE | CNTVTY | NEIGHBOURS |
|------|--------|------------|
| 1    | 2      | 2 3        |
| 2    | 3      | 1 4 5      |
| 3    | 3      | 1 6 7      |
| 4    | 3      | 2 8 9      |
| 5    | 3      | 2 10 11    |
| 6    | 3      | 3 12 13    |
| 7    | 3      | 3 14 15    |
| 8    | 1      | 4          |
| 9    | 1      | 4          |
| 10   | 1      | 5          |
| 11   | 1      | 5          |
| 12   | 1      | 6          |
| 13   | 1      | 6          |
| 14   | 1      | 7          |
| 15   | 1      | 7          |

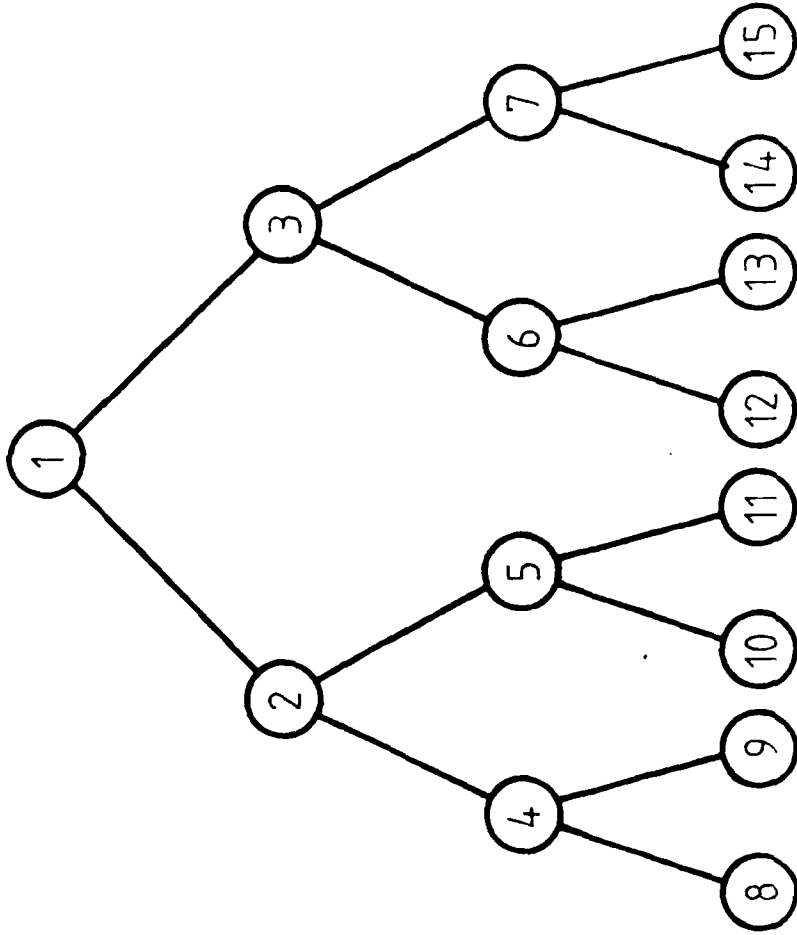

Figure 21

SIMULATION DURATION (seconds) = 0.10  
 AVERAGE DELAY TIME (microseconds) = 20433.8  
 TOTAL EXTERNAL TRAFFIC = 797  
 TOTAL HOST CONTENT = 13  
 MESSAGES IN COMMUNICATION SUBSYSTEM = 13  
 TOTAL DELIVERED BUT UNACKNOWLEDGED = 771  
 PERCENTAGE OF UNACKNOWLEDGED = 0.0

nodal traffic statistics in number of messages

| HOST ID | EXTERNAL INPUT | DELIVERED | UNACKNOWLEDGED | CURRENT CONTENT | RECEIVED MESSAGES |
|---------|----------------|-----------|----------------|-----------------|-------------------|
| 1       | 50             | 48        | 0              | 1               | 55                |
| 2       | 50             | 49        | 0              | 1               | 57                |
| 3       | 50             | 48        | 0              | 1               | 44                |
| 4       | 50             | 48        | 0              | 1               | 63                |
| 5       | 50             | 48        | 0              | 1               | 42                |
| 6       | 50             | 48        | 0              | 1               | 52                |
| 7       | 50             | 49        | 0              | 1               | 52                |
| 8       | 50             | 49        | 0              | 1               | 49                |
| 9       | 50             | 48        | 0              | 1               | 44                |
| 10      | 50             | 48        | 0              | 1               | 47                |
| 11      | 50             | 49        | 0              | 1               | 48                |
| 12      | 50             | 48        | 0              | 1               | 43                |
| 13      | 50             | 47        | 0              | 1               | 39                |
| 14      | 49             | 48        | 0              | 0               | 41                |
| 15      | 49             | 48        | 0              | 0               | 43                |
| 16      | 49             | 48        | 0              | 0               | 52                |
| TOTALS  | 797            | 771       | 0              | 13              | 771               |

CONNECTION TABLE

| NODE | CONTINITY | NEIGHBOURS |
|------|-----------|------------|
| 1    | 1         | 5          |
| 2    | 2         | 3 6        |
| 3    | 2         | 2 7        |
| 4    | 1         | 8          |
| 5    | 3         | 1 6 9      |
| 6    | 3         | 2 5 10     |
| 7    | 3         | 3 8 11     |
| 8    | 3         | 4 7 12     |
| 9    | 2         | 5 13       |
| 10   | 3         | 6 11 14    |
| 11   | 3         | 7 10 15    |
| 12   | 2         | 8 16       |
| 13   | 2         | 9 14       |
| 14   | 2         | 10 13      |
| 15   | 2         | 11 16      |
| 16   | 2         | 12 15      |

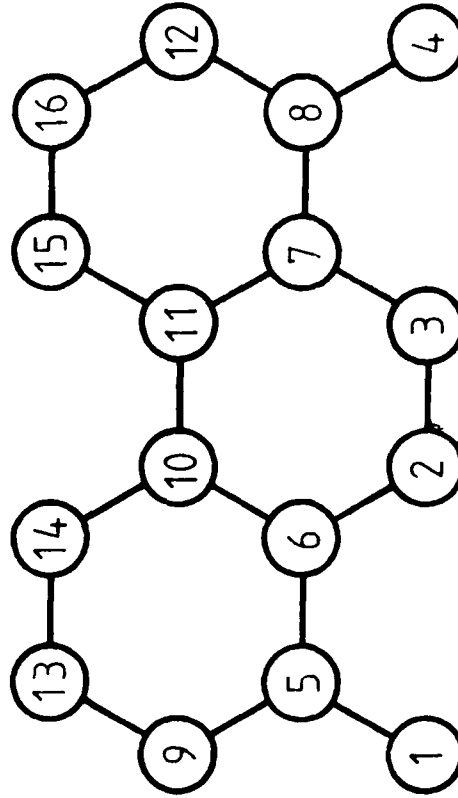

Figure 22

COMMUNICATION (seconds) = 1.16  
 AVERAGE DELAY TIME (microseconds) = 1776.3  
 TOTAL EXTERNAL TRAFFIC = 796  
 TOTAL HOST CONTENT = 17  
 MESSAGES IN COMMUNICATION SUBSYSTEM = 62  
 MESSAGES DELIVERED = 717  
 TOTAL DELIVERED BUT UNACKNOWLEDGED = 0  
 PERCENTAGE OF UNACKNOWLEDGED = 0.2

MODAL TRAFFIC STATISTICS IN NUMBER OF MESSAGES

| HOST ID | EXTERNAL INPUT | DELIVERED | UNACKNOWLEDGED | CURRENT CONTENT | RECEIVED MESSAGES | MESSAGES IN CS |
|---------|----------------|-----------|----------------|-----------------|-------------------|----------------|
| 1       | 50             | 44        | 0              | 1               | 46                | 1              |
| 2       | 50             | 45        | 0              | 1               | 56                | 3              |
| 3       | 50             | 45        | 0              | 1               | 47                | 7              |
| 4       | 50             | 46        | 0              | 1               | 54                | 5              |
| 5       | 50             | 45        | 0              | 1               | 49                | 5              |
| 6       | 50             | 45        | 0              | 1               | 44                | 6              |
| 7       | 50             | 46        | 0              | 1               | 46                | 4              |
| 8       | 50             | 45        | 0              | 1               | 47                | 2              |
| 9       | 50             | 45        | 0              | 1               | 43                | 5              |
| 10      | 50             | 46        | 0              | 1               | 46                | 2              |
| 11      | 50             | 45        | 0              | 1               | 39                | 3              |
| 12      | 50             | 40        | 0              | 1               | 41                | 4              |
| 13      | 49             | 42        | 0              | 1               | 37                | 4              |
| 14      | 49             | 44        | 0              | 1               | 39                | 5              |
| 15      | 49             | 44        | 0              | 1               | 45                | 5              |
| 16      | 49             | 44        | 0              | 2               | 38                | 1              |
| TOTALS  | 796            | 717       | 0              | 17              | 717               | 62             |

CONNECTION TABLE

| NODE | CONTIVITY | NEIGHBOURS |
|------|-----------|------------|
| 1    | 2         | 5          |
| 2    | 3         | 1 3 6      |
| 3    | 3         | 2 4 7      |
| 4    | 2         | 3 8        |
| 5    | 3         | 1 6 9      |
| 6    | 4         | 2 5 7 10   |
| 7    | 4         | 3 6 8 11   |
| 8    | 3         | 4 7 12     |
| 9    | 3         | 5 10 13    |
| 10   | 4         | 6 9 11 14  |
| 11   | 4         | 7 10 12 15 |
| 12   | 3         | 8 11 16    |
| 13   | 2         | 9 14       |
| 14   | 3         | 10 13 15   |
| 15   | 3         | 11 14 16   |
| 16   | 2         | 12 15      |

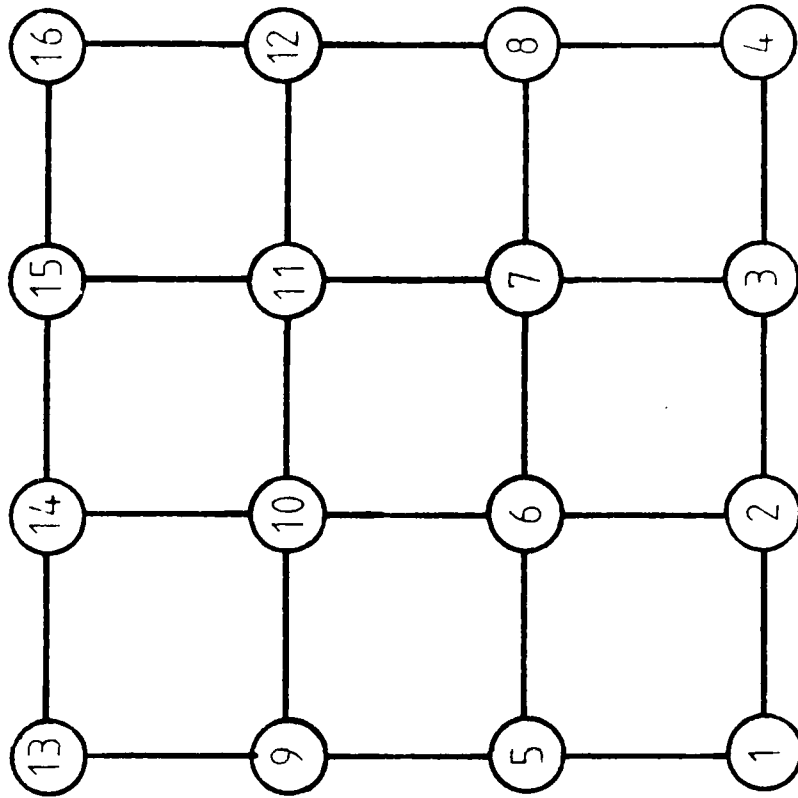

Figure 23

```

SIMULATION DURATION (SECONDS)      = 0.10
AVERAGE DELAY TIME (MICROSECONDS) = 17226.3
TOTAL EXTERNAL TRAFFIC            = 793
TOTAL HOST CONTENT                 = 17
MESSAGES IN COMMUNICATION SUBSYSTEM = 55
MESSAGES DELIVERED                 = 721
TOTAL DELIVERED BUT UNACKNOWLEDGED = 0
PERCENTAGE OF UNACKNOWLEDGE       = 0.0
    
```

MODAL TRAFFIC STATISTICS IN NUMBER OF MESSAGES

| HOST ID | EXTERNAL INPUT | DELIVERED | UNACKNOWLEDGED | CURRENT CONTENT | RECEIVED MESSAGES |
|---------|----------------|-----------|----------------|-----------------|-------------------|
| 1       | 50             | 45        | 0              | 1               | 43                |
| 2       | 50             | 45        | 0              | 1               | 59                |
| 3       | 50             | 46        | 0              | 1               | 48                |
| 4       | 50             | 46        | 0              | 1               | 48                |
| 5       | 50             | 46        | 0              | 1               | 48                |
| 6       | 50             | 45        | 0              | 1               | 42                |
| 7       | 50             | 45        | 0              | 1               | 46                |
| 8       | 50             | 46        | 0              | 1               | 45                |
| 9       | 50             | 45        | 0              | 1               | 43                |
| 10      | 49             | 46        | 0              | 1               | 41                |
| 11      | 49             | 43        | 0              | 1               | 45                |
| 12      | 49             | 46        | 0              | 1               | 38                |
| 13      | 49             | 45        | 0              | 1               | 36                |
| 14      | 49             | 44        | 0              | 1               | 34                |
| 15      | 49             | 44        | 0              | 1               | 51                |
| 16      | 49             | 43        | 0              | 2               | 52                |
| TOTALS  | 793            | 721       | 0              | 17              | 721               |

CONNECTION TABLE

| NODE | CONTIVITY | NEIGHBOURS |
|------|-----------|------------|
| 1    | 3         | 4 5 13     |
| 2    | 3         | 3 6 14     |
| 3    | 3         | 2 7 15     |
| 4    | 3         | 1 8 16     |
| 5    | 3         | 1 6 9      |
| 6    | 3         | 2 5 10     |
| 7    | 3         | 3 8 11     |
| 8    | 3         | 4 7 12     |
| 9    | 3         | 5 12 13    |
| 10   | 3         | 6 11 14    |
| 11   | 3         | 7 10 15    |
| 12   | 3         | 8 9 16     |
| 13   | 3         | 1 9 14     |
| 14   | 3         | 2 10 13    |
| 15   | 3         | 3 11 16    |
| 16   | 3         | 4 12 15    |

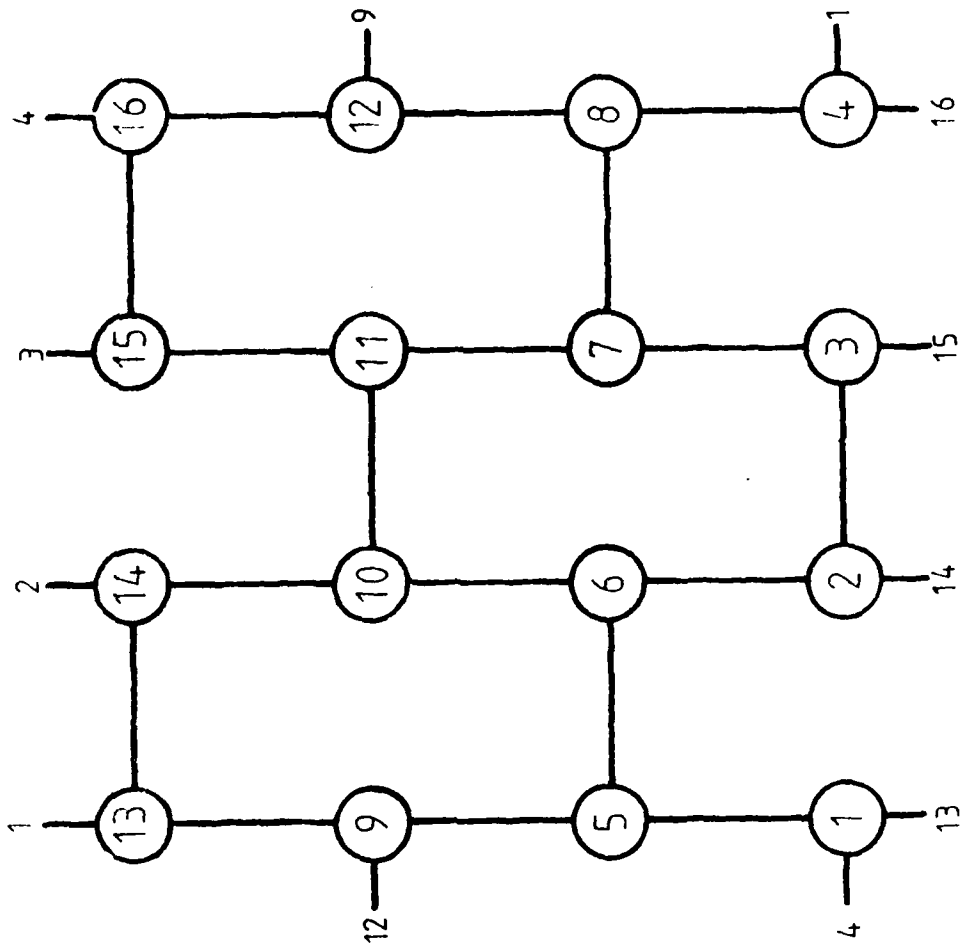

Figure 24

DELIVERY DELAY TIME (MINUTES) = 14.10  
 AVERAGE DELAY TIME (MINUTES) = 14.10  
 TOTAL EXTERNAL TRAFFIC = 342  
 TOTAL HOST CONTENT = 16  
 MESSAGES IN COMMUNICATION SUBSYSTEM = 47  
 MESSAGES DELIVERED = 655  
 TOTAL DELIVERED BUT UNACKNOWLEDGED = 0  
 PERCENTAGE OF UNACKNOWLEDGED = 0.0

LOCAL TRAFFIC STATISTICS IN NUMBER OF MESSAGES

| HOST ID | EXTERNAL INPUT | DELIVERED | UNACKNOWLEDGED | CURRENT CONTENT | RECEIVED MESSAGES | MESSAGES IN CPU |
|---------|----------------|-----------|----------------|-----------------|-------------------|-----------------|
| 1       | 50             | 45        | 0              | 1               | 48                | 6               |
| 2       | 50             | 46        | 0              | 1               | 55                | 3               |
| 3       | 50             | 45        | 0              | 1               | 51                | 2               |
| 4       | 50             | 46        | 0              | 1               | 42                | 3               |
| 5       | 50             | 47        | 0              | 1               | 52                | 3               |
| 6       | 50             | 45        | 0              | 1               | 52                | 4               |
| 7       | 50             | 46        | 0              | 1               | 37                | 3               |
| 8       | 50             | 46        | 0              | 1               | 45                | 4               |
| 9       | 50             | 47        | 0              | 1               | 48                | 5               |
| 10      | 50             | 46        | 0              | 1               | 32                | 2               |
| 11      | 50             | 46        | 0              | 1               | 29                | 1               |
| 12      | 50             | 46        | 0              | 1               | 36                | 3               |
| 13      | 50             | 45        | 0              | 1               | 39                | 1               |
| 14      | 49             | 43        | 0              | 1               | 42                | 4               |
| 15      | 49             | 44        | 0              | 2               | 49                | 3               |
| TOTALS  | 748            | 685       | 0              | 16              | 685               | 47              |

CONNECTION TABLE

| NODE | ACTIVITY | NEIGHBOURS |
|------|----------|------------|
| 1    | 3        | 2 5 6      |
| 2    | 3        | 1 3 7      |
| 3    | 3        | 2 4 8      |
| 4    | 3        | 3 5 9      |
| 5    | 3        | 1 4 10     |
| 6    | 4        | 1 7 10 11  |
| 7    | 4        | 2 6 8 12   |
| 8    | 4        | 3 7 9 13   |
| 9    | 4        | 4 6 12 14  |
| 10   | 4        | 5 6 9 15   |
| 11   | 3        | 6 12 15    |
| 12   | 3        | 7 11 13    |
| 13   | 3        | 8 12 14    |
| 14   | 3        | 9 13 15    |
| 15   | 3        | 10 11 14   |

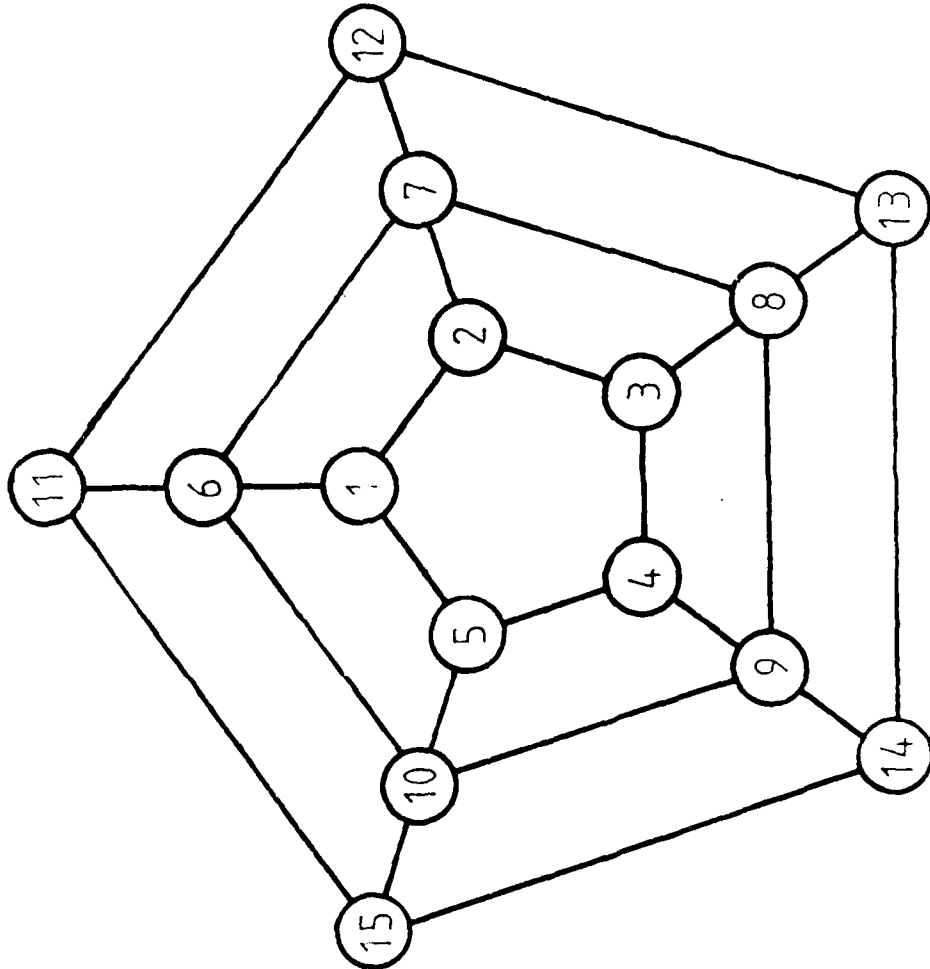

Figure 25

SIMULATION DURATION (seconds) = 0.10  
 AVERAGE DELAY TIME (microseconds) = 15961.0  
 TOTAL EXTERNAL TRAFFIC = 786  
 TOTAL HOST CONTENT = 17  
 MESSAGES IN COMMUNICATION SUBSYSTEM = 47  
 MESSAGES DELIVERED = 722  
 TOTAL DELIVERED BUT UNACKNOWLEDGED = 0  
 PERCENTAGE OF UNACKNOWLEDGED = 0.0

NODAL TRAFFIC STATISTICS IN NUMBER OF MESSAGES  
 .....

| HOST ID | EXTERNAL INPUT | DELIVERED | UNACKNOWLEDGED | CURRENT CONTENT | RECEIVED MESSAGES |
|---------|----------------|-----------|----------------|-----------------|-------------------|
| 1       | 50             | 46        | 0              | 1               | 49                |
| 2       | 50             | 47        | 0              | 1               | 53                |
| 3       | 49             | 46        | 0              | 1               | 48                |
| 4       | 49             | 45        | 0              | 1               | 60                |
| 5       | 49             | 45        | 0              | 1               | 44                |
| 6       | 49             | 43        | 0              | 1               | 41                |
| 7       | 49             | 44        | 0              | 1               | 50                |
| 8       | 49             | 45        | 0              | 1               | 48                |
| 9       | 49             | 45        | 0              | 1               | 43                |
| 10      | 49             | 45        | 0              | 1               | 36                |
| 11      | 49             | 45        | 0              | 1               | 41                |
| 12      | 49             | 44        | 0              | 1               | 42                |
| 13      | 49             | 45        | 0              | 1               | 48                |
| 14      | 49             | 46        | 0              | 1               | 34                |
| 15      | 49             | 45        | 0              | 1               | 35                |
| 16      | 49             | 44        | 0              | 2               | 50                |
| TOTALS  | 786            | 722       | 0              | 17              | 722               |

.....

CONNECTION TABLE  
 .....

| NODE | CNTIVITY | NEIGHBOURS |
|------|----------|------------|
| 1    | 4        | 2 4 5 13   |
| 2    | 4        | 1 3 6 14   |
| 3    | 4        | 2 4 7 15   |
| 4    | 4        | 1 3 8 16   |
| 5    | 4        | 1 6 8 9    |
| 6    | 4        | 2 5 7 10   |
| 7    | 4        | 3 6 8 11   |
| 8    | 4        | 4 5 7 12   |
| 9    | 4        | 5 10 11 13 |
| 10   | 4        | 6 9 11 14  |
| 11   | 4        | 7 10 12 15 |
| 12   | 4        | 8 9 11 16  |
| 13   | 4        | 1 9 14 16  |
| 14   | 4        | 2 10 13 15 |
| 15   | 4        | 3 11 14 16 |
| 16   | 4        | 4 12 13 15 |

.....

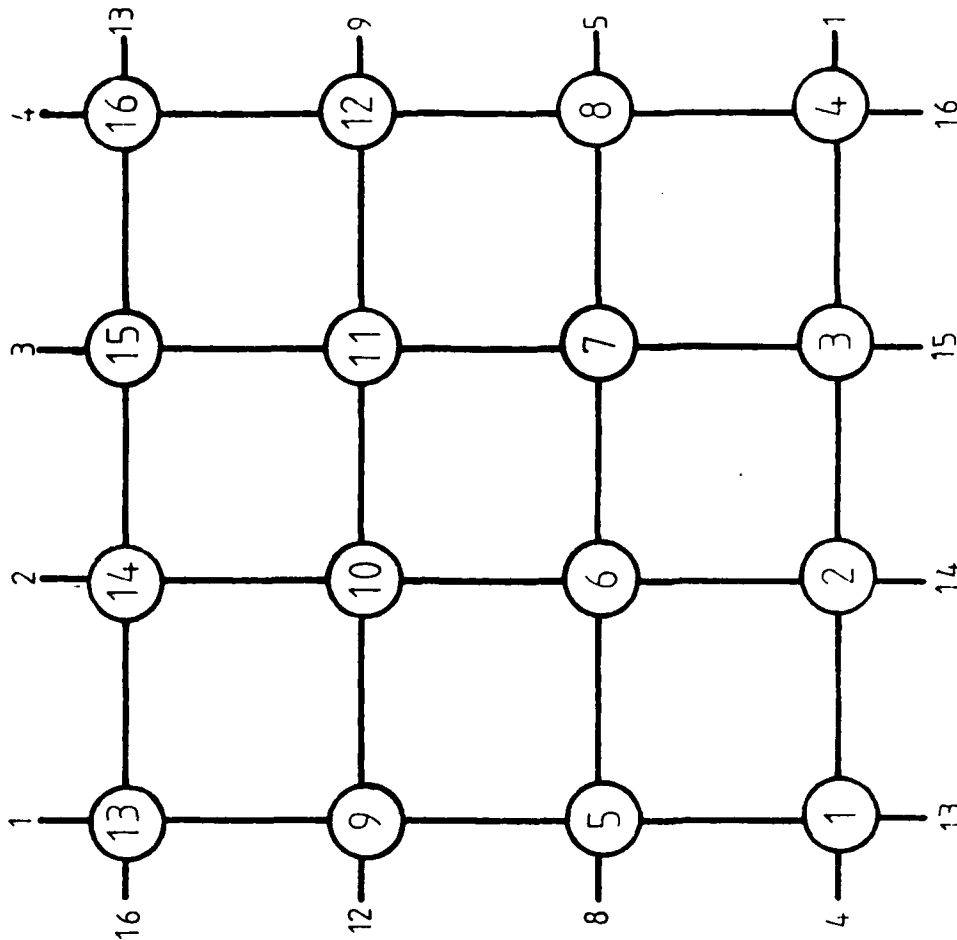

Figure 26

SIMULATION DURATION (SECONDS) = 1.012  
 AVERAGE DELAY TIME (MICROSECONDS) = 14046.6  
 TOTAL EXTERNAL TRAFFIC = 17  
 TOTAL HOST COUNTERS = 50  
 MESSAGES IN COMMUNICATION SUBSYSTEM = 716  
 MESSAGES DELIVERED = 0  
 TOTAL DELIVERED BUT UNACKNOWLEDGED = 0.0  
 PERCENTAGE OF UNACKNOWLEDGED = 0.0

.....  
 NODAL TRAFFIC STATISTICS IN NUMBER OF MESSAGES  
 .....

| HOST ID | EXTERNAL INPUT | DELIVERED | UNACKNOWLEDGED | CURRENT CONTENT | RECEIVED MESSAGES |
|---------|----------------|-----------|----------------|-----------------|-------------------|
| 1       | 49             | 45        | 0              | 1               | 47                |
| 2       | 49             | 44        | 0              | 1               | 54                |
| 3       | 49             | 46        | 0              | 1               | 52                |
| 4       | 49             | 46        | 0              | 1               | 59                |
| 5       | 49             | 44        | 0              | 1               | 41                |
| 6       | 49             | 45        | 0              | 1               | 43                |
| 7       | 49             | 45        | 0              | 1               | 53                |
| 8       | 49             | 45        | 0              | 1               | 44                |
| 9       | 49             | 45        | 0              | 1               | 45                |
| 10      | 49             | 45        | 0              | 1               | 37                |
| 11      | 49             | 45        | 0              | 1               | 39                |
| 12      | 49             | 44        | 0              | 1               | 44                |
| 13      | 49             | 44        | 0              | 1               | 47                |
| 14      | 49             | 45        | 0              | 1               | 31                |
| 15      | 49             | 45        | 0              | 1               | 34                |
| 16      | 48             | 43        | 0              | 2               | 46                |
| TOTALS  | 783            | 716       | 0              | 17              | 716               |

.....  
 CONNECTION TABLE  
 .....

| NODE | CNTIVITY | NEIGHBOURS |
|------|----------|------------|
| 1    | 4        | 2 3 5 9    |
| 2    | 4        | 1 4 6 18   |
| 3    | 4        | 1 4 7 11   |
| 4    | 4        | 2 3 8 12   |
| 5    | 4        | 1 6 7 13   |
| 6    | 4        | 2 5 8 14   |
| 7    | 4        | 3 5 8 15   |
| 8    | 4        | 4 6 7 16   |
| 9    | 4        | 1 10 11 13 |
| 10   | 4        | 2 9 12 14  |
| 11   | 4        | 3 9 12 15  |
| 12   | 4        | 4 10 11 16 |
| 13   | 4        | 5 9 14 15  |
| 14   | 4        | 6 10 13 16 |
| 15   | 4        | 7 11 13 16 |
| 16   | 4        | 8 12 14 15 |

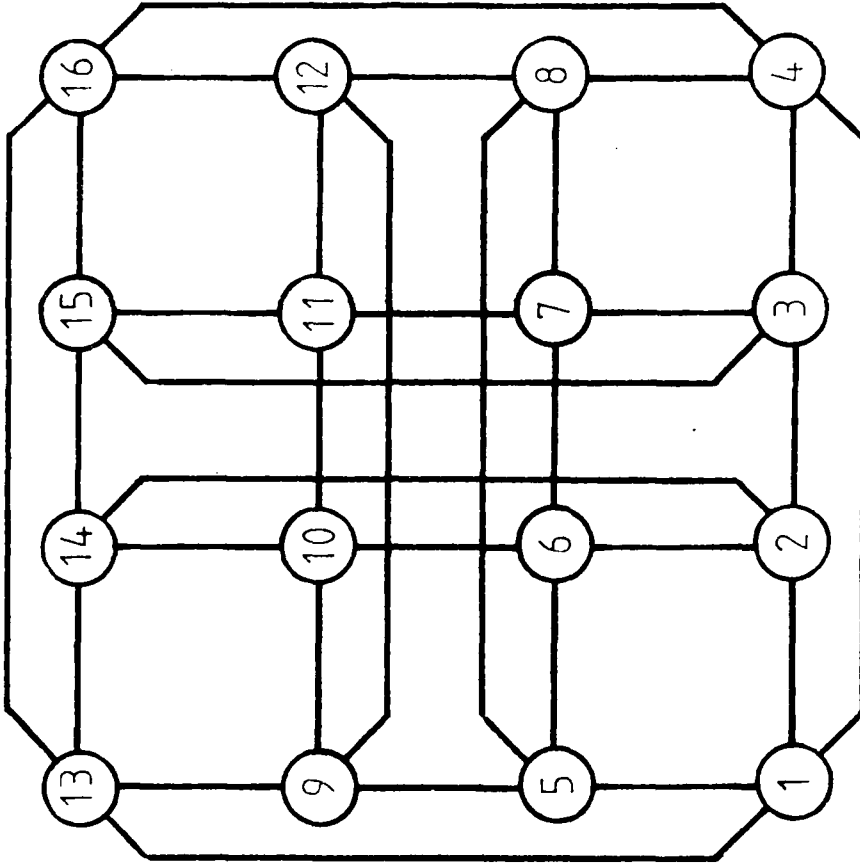

Figure 27

SIMULATION DURATION (SECONDS) = 2.14  
 AVERAGE DELAY TIME (MICROSECONDS) = 16730.1  
 TOTAL EXTERNAL TRAFFIC = 723  
 TOTAL HOST CONTENT = 17  
 MESSAGES IN COMMUNICATION SUBSYSTEM = 50  
 MESSAGES DELIVERED = 723  
 TOTAL DELIVERED BUT UNACKNOWLEDGED = 0  
 PERCENTAGE OF UNACKNOWLEDGED = 0.0

MODAL TRAFFIC STATISTICS IN NUMBER OF MESSAGES

| HOST ID | EXTERNAL INPUT | DELIVERED | UNACKNOWLEDGED | CURRENT CONTENT | RECEIVED MESSAGES | MESSAGES IN QUEUE |
|---------|----------------|-----------|----------------|-----------------|-------------------|-------------------|
| 1       | 50             | 44        | 0              | 1               | 60                | 1                 |
| 2       | 50             | 40        | 0              | 1               | 55                | 4                 |
| 3       | 50             | 46        | 0              | 1               | 49                | 3                 |
| 4       | 50             | 40        | 0              | 1               | 54                | 2                 |
| 5       | 50             | 46        | 0              | 1               | 44                | 6                 |
| 6       | 50             | 46        | 0              | 1               | 43                | 2                 |
| 7       | 49             | 45        | 0              | 1               | 48                | 2                 |
| 8       | 49             | 45        | 0              | 1               | 36                | 3                 |
| 9       | 49             | 44        | 0              | 1               | 42                | 4                 |
| 10      | 49             | 46        | 0              | 1               | 45                | 5                 |
| 11      | 49             | 45        | 0              | 1               | 44                | 3                 |
| 12      | 49             | 40        | 0              | 1               | 44                | 2                 |
| 13      | 49             | 44        | 0              | 1               | 38                | 3                 |
| 14      | 49             | 45        | 0              | 1               | 32                | 4                 |
| 15      | 49             | 45        | 0              | 1               | 44                | 5                 |
| 16      | 49             | 44        | 0              | 2               | 44                | 1                 |
| TOTALS  | 790            | 723       | 0              | 17              | 723               | 50                |

CONNECTION TABLE

| NODE | CONTIGUOUS              | NEIGHBOURS |
|------|-------------------------|------------|
| 1    | 2                       | 5          |
| 2    | 1, 3                    | 6, 7       |
| 3    | 2, 4                    | 8          |
| 4    | 3, 7                    | 8          |
| 5    | 1, 2, 6                 | 9, 10, 11  |
| 6    | 2, 3, 5, 7              | 12         |
| 7    | 2, 3, 4, 6, 8           | 11, 12     |
| 8    | 3, 4, 7, 12             | 13         |
| 9    | 5, 10, 13               | 14         |
| 10   | 5, 9                    | 11, 13, 14 |
| 11   | 5, 6, 7, 10, 12, 14, 15 | 15         |
| 12   | 6, 7, 8, 11, 15, 16     | 16         |
| 13   | 9, 10, 14               |            |
| 14   | 9, 10, 11, 13, 15       |            |
| 15   | 11, 12, 14, 16          |            |
| 16   | 12, 15                  |            |

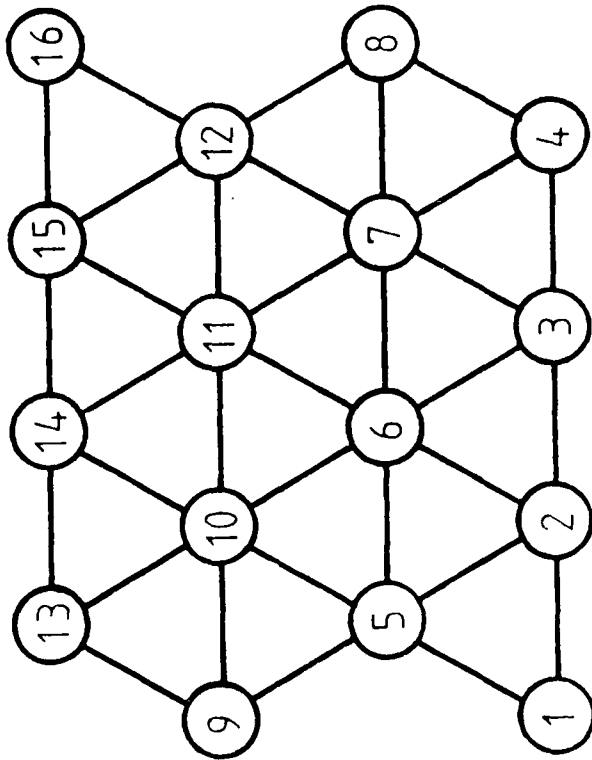

Figure 28

SIMULATION DURATION (seconds) = 0.10  
 AVERAGE DELAY TIME (microseconds) = 14243.4  
 TOTAL EXTERNAL TRAFFIC = 799  
 TOTAL HOST CONTENT = 17  
 MESSAGES IN COMMUNICATION SUBSYSTEM = 44  
 MESSAGES DELIVERED = 738  
 TOTAL DELIVERED BUT UNACKNOWLEDGED = 0  
 PERCENTAGE OF UNACKNOWLEDGED = 0.0

\*\*\*\*\*  
 NODAL TRAFFIC STATISTICS IN NUMBER OF MESSAGES  
 \*\*\*\*\*

| HOST ID | EXTERNAL INPUT | DELIVERED | UNACKNOWLEDGED | CURRENT CONTENT | RECEIVED MESSAGES |
|---------|----------------|-----------|----------------|-----------------|-------------------|
| 1       | 50             | 46        | 0              | 1               | 51                |
| 2       | 50             | 46        | 0              | 1               | 62                |
| 3       | 50             | 46        | 0              | 1               | 50                |
| 4       | 50             | 46        | 0              | 1               | 65                |
| 5       | 50             | 47        | 0              | 1               | 39                |
| 6       | 50             | 46        | 0              | 1               | 40                |
| 7       | 50             | 46        | 0              | 1               | 59                |
| 8       | 50             | 46        | 0              | 1               | 46                |
| 9       | 50             | 47        | 0              | 1               | 41                |
| 10      | 50             | 46        | 0              | 1               | 35                |
| 11      | 50             | 46        | 0              | 1               | 38                |
| 12      | 50             | 46        | 0              | 1               | 47                |
| 13      | 50             | 47        | 0              | 1               | 49                |
| 14      | 50             | 46        | 0              | 1               | 33                |
| 15      | 50             | 46        | 0              | 1               | 33                |
| 16      | 49             | 45        | 0              | 2               | 50                |
| TOTALS  | 799            | 738       | 0              | 17              | 738               |

\*\*\*\*\*  
 CONNECTION TABLE  
 \*\*\*\*\*

| MODE | CNTIVITY | NEIGHBOURS   |
|------|----------|--------------|
| 1    | 5        | 2 4 5 11 13  |
| 2    | 5        | 1 3 6 12 14  |
| 3    | 5        | 2 4 7 9 15   |
| 4    | 5        | 1 3 8 10 16  |
| 5    | 5        | 1 6 8 9 15   |
| 6    | 5        | 2 5 7 10 16  |
| 7    | 5        | 3 6 8 11 13  |
| 8    | 5        | 4 5 7 12 14  |
| 9    | 5        | 3 6 9 11 14  |
| 10   | 5        | 4 6 9 12 15  |
| 11   | 5        | 1 7 10 12 15 |
| 12   | 5        | 2 8 9 11 16  |
| 13   | 5        | 1 7 9 14 16  |
| 14   | 5        | 2 8 10 13 15 |
| 15   | 5        | 3 5 11 14 16 |
| 16   | 5        | 4 6 12 13 15 |

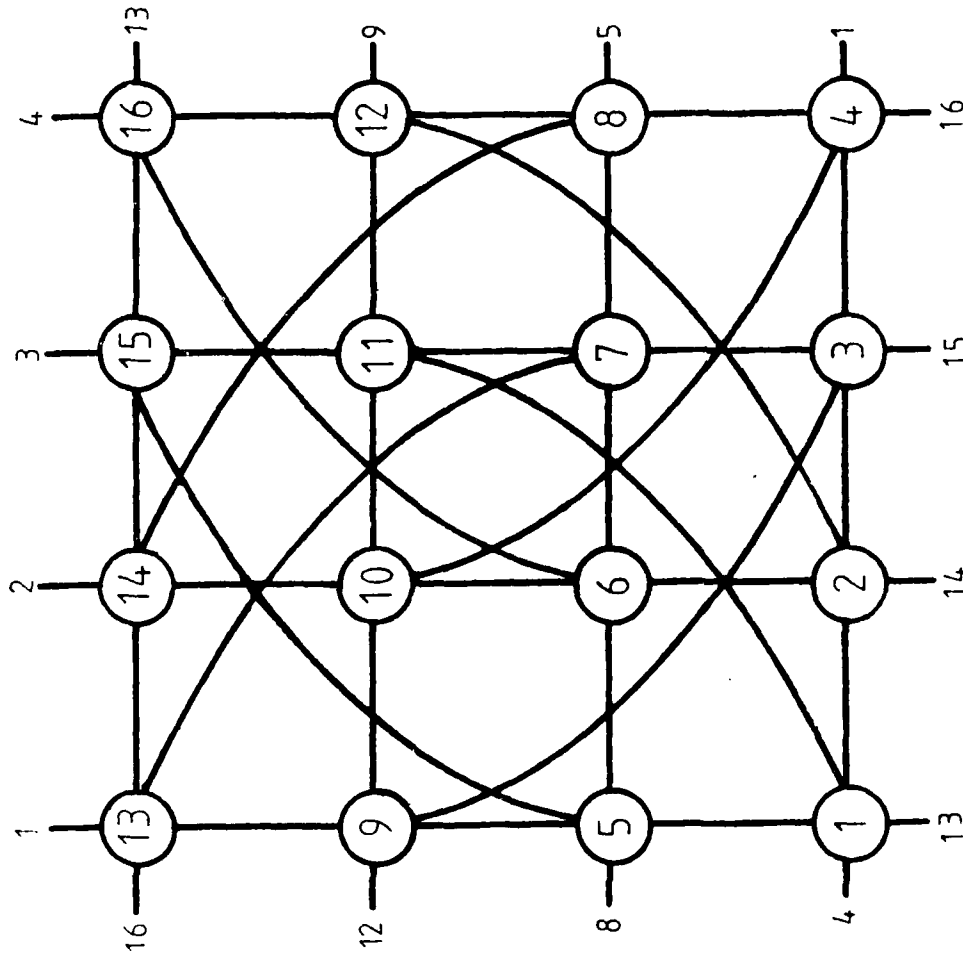
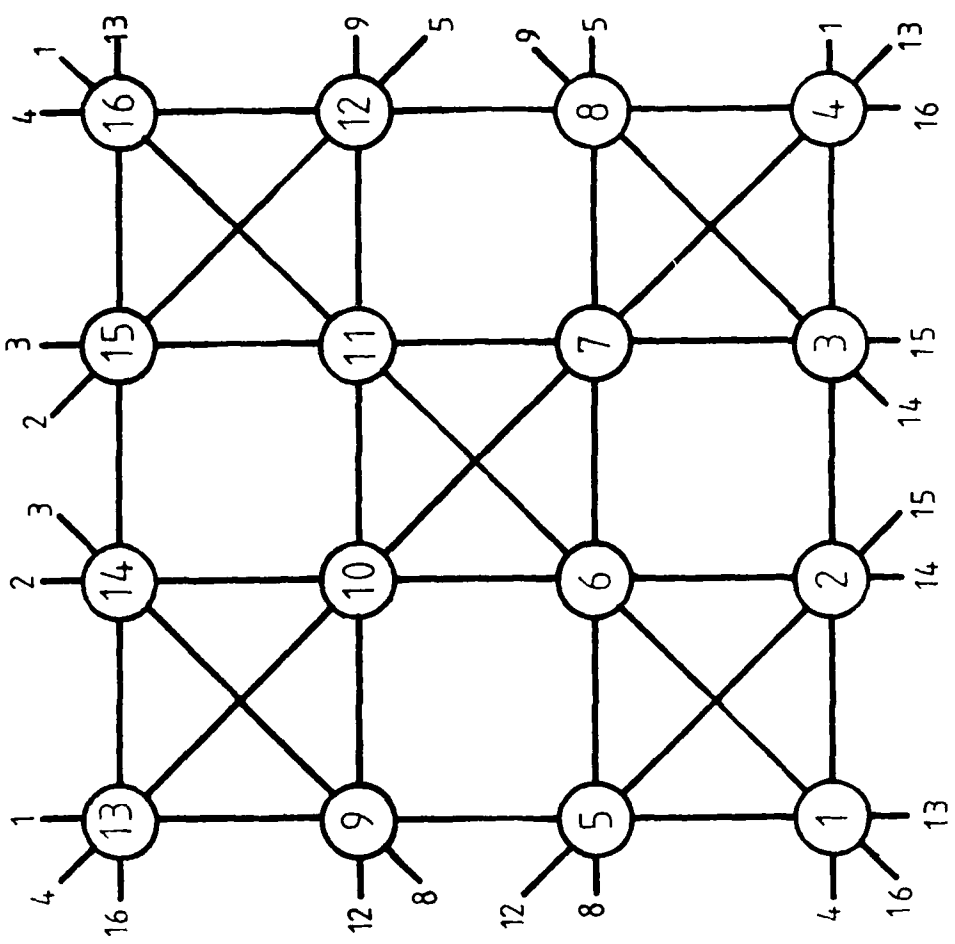

Figure 29

SIMULATION DURATION (seconds) = 6.10  
 AVERAGE DELAY TIME (microseconds) = 13939.6  
 TOTAL EXTERNAL TRAFFIC = 790  
 TOTAL HOST CONTENT = 17  
 MESSAGES IN COMMUNICATION SUBSYSTEM = 42  
 MESSAGES DELIVERED = 739  
 TOTAL DELIVERED BUT UNACKNOWLEDGED = 0  
 PERCENTAGE OF UNACKNOWLEDGED = 0.0



\*\*\*\*\*  
 NODAL TRAFFIC STATISTICS IN NUMBER OF MESSAGES  
 \*\*\*\*\*

| HOST ID | EXTERNL INPUT | DELI- VERED | UNACKN- OBLISHED | CURRENT CONTENT | RECEIVED MESSAGES IN CC |
|---------|---------------|-------------|------------------|-----------------|-------------------------|
| 1       | 50            | 46          | 0                | 1               | 54                      |
| 2       | 50            | 46          | 0                | 1               | 55                      |
| 3       | 50            | 46          | 0                | 1               | 44                      |
| 4       | 50            | 47          | 0                | 1               | 67                      |
| 5       | 50            | 47          | 0                | 1               | 39                      |
| 6       | 50            | 46          | 0                | 1               | 39                      |
| 7       | 50            | 46          | 0                | 1               | 56                      |
| 8       | 50            | 47          | 0                | 1               | 44                      |
| 9       | 50            | 46          | 0                | 1               | 41                      |
| 10      | 50            | 46          | 0                | 1               | 37                      |
| 11      | 50            | 46          | 0                | 1               | 42                      |
| 12      | 50            | 46          | 0                | 1               | 54                      |
| 13      | 50            | 46          | 0                | 1               | 35                      |
| 14      | 50            | 46          | 0                | 1               | 37                      |
| 15      | 49            | 45          | 0                | 2               | 53                      |
| 16      | 49            | 45          | 0                | 2               | 53                      |
| TOTALS  | 798           | 739         | 0                | 17              | 739                     |

\*\*\*\*\*

\*\*\*\*\*  
 CONNECTION TABLE  
 \*\*\*\*\*

| NODE | CONTIVITY | NEIGHBOURS      |
|------|-----------|-----------------|
| 1    | 6         | 2 4 5 6 13 16   |
| 2    | 6         | 1 3 5 6 14 15   |
| 3    | 6         | 2 4 7 8 14 15   |
| 4    | 6         | 1 3 7 8 13 16   |
| 5    | 6         | 1 2 6 6 9 12    |
| 6    | 6         | 1 2 5 7 10 11   |
| 7    | 6         | 3 4 6 8 10 11   |
| 8    | 6         | 3 4 5 7 9 12    |
| 9    | 6         | 5 8 10 12 13 14 |
| 10   | 6         | 6 7 9 11 13 14  |
| 11   | 6         | 6 7 10 12 15 16 |
| 12   | 6         | 9 11 15 16      |
| 13   | 6         | 1 4 9 16 14 15  |
| 14   | 6         | 2 3 9 14 13 15  |
| 15   | 6         | 2 3 11 12 14 16 |
| 16   | 6         | 1 4 11 12 13 15 |

\*\*\*\*\*

SIMULATED DURATION (seconds) = 6.10  
 AREA OF LOCAL TIME (microseconds) = 15.614  
 TOTAL EXTERNAL TRAFFIC = 799  
 TOTAL HOST CAPACITY = 17  
 MESSAGES IN COMMUNICATION SUBSYSTEM = 43  
 MESSAGES DELIVERED = 739  
 TOTAL DELIVERED NOT UNACKNOWLEDGED = 0  
 PERCENTAGE OF UNACKNOWLEDGED = 0.0

LOCAL TRAFFIC STATISTICS IN NUMBER OF MESSAGES

| HOST ID | EXTERNAL INPUT | DELIVERED | UNACKNOWLEDGED | CURRENT CONTENT | RECEIVED MESSAGES |
|---------|----------------|-----------|----------------|-----------------|-------------------|
| 1       | 50             | 40        | 0              | 17              | 51                |
| 2       | 52             | 40        | 0              | 17              | 63                |
| 3       | 50             | 40        | 0              | 17              | 50                |
| 4       | 50             | 47        | 0              | 17              | 65                |
| 5       | 50             | 47        | 0              | 17              | 39                |
| 6       | 50             | 46        | 0              | 17              | 40                |
| 7       | 50             | 40        | 0              | 17              | 58                |
| 8       | 50             | 46        | 0              | 17              | 40                |
| 9       | 50             | 47        | 0              | 17              | 41                |
| 10      | 50             | 46        | 0              | 17              | 35                |
| 11      | 50             | 46        | 0              | 17              | 38                |
| 12      | 50             | 40        | 0              | 17              | 47                |
| 13      | 50             | 40        | 0              | 17              | 50                |
| 14      | 50             | 40        | 0              | 17              | 33                |
| 15      | 50             | 47        | 0              | 17              | 33                |
| 16      | 49             | 45        | 0              | 17              | 50                |
| TOTALS  | 799            | 739       | 0              | 17              | 739               |

CONNECTION TABLE

| NODE | CRIVITY | NEIGHBOURS      |
|------|---------|-----------------|
| 1    | 6       | 7 4 5 8 13 14   |
| 2    | 6       | 1 3 5 6 14 15   |
| 3    | 6       | 2 4 6 7 15 16   |
| 4    | 6       | 1 3 7 8 13 16   |
| 5    | 6       | 1 2 6 9 10 12   |
| 6    | 6       | 2 3 5 7 9 10 11 |
| 7    | 6       | 3 4 6 8 10 11   |
| 8    | 6       | 1 4 5 7 11 12   |
| 9    | 6       | 5 6 10 12 13 16 |
| 10   | 6       | 6 7 9 11 13 14  |
| 11   | 6       | 7 8 10 12 14 15 |
| 12   | 6       | 5 8 9 11 15 16  |
| 13   | 6       | 1 4 9 12 14 16  |
| 14   | 6       | 1 2 10 11 13 15 |
| 15   | 6       | 2 3 11 12 14 16 |
| 16   | 6       | 3 4 9 12 13 15  |

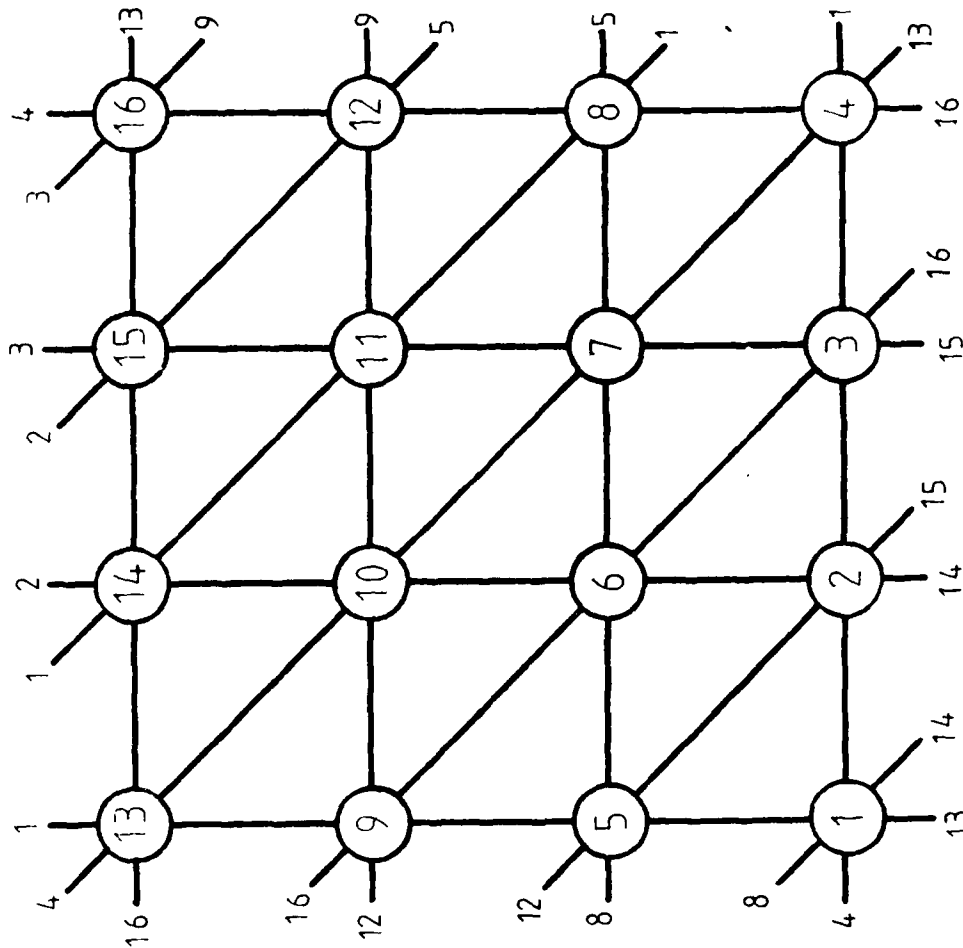

Figure 31

SIMULATION DURATION (SECONDS) = 6.11  
 AVERAGE DELAY TIME (MICROSECONDS) = 14051.0  
 TOTAL INTERNAL TRAFFIC = 799  
 MESSAGES IN COMMUNICATION SUBSYSTEM = 17  
 MESSAGES DELIVERED = 42  
 TOTAL DELIVERED BUT UNACKNOWLEDGED = 740  
 PERCENTAGE OF UNACKNOWLEDGED = 0.0

.....  
 NODAL TRAFFIC STATISTICS IN NUMBER OF MESSAGES  
 .....

| HOST ID | EXTFRNL INPUT | DELI- VERED | UNACKN- CALGEGD | CURRENT CONTENT | RECIEVD MESSAGES IN CG |
|---------|---------------|-------------|-----------------|-----------------|------------------------|
| 1       | 50            | 46          | 0               | 1               | 51                     |
| 2       | 50            | 46          | 0               | 1               | 63                     |
| 3       | 50            | 46          | 0               | 1               | 51                     |
| 4       | 50            | 47          | 0               | 1               | 65                     |
| 5       | 50            | 47          | 0               | 1               | 39                     |
| 6       | 50            | 46          | 0               | 1               | 40                     |
| 7       | 50            | 46          | 0               | 1               | 58                     |
| 8       | 50            | 47          | 0               | 1               | 46                     |
| 9       | 50            | 47          | 0               | 1               | 41                     |
| 10      | 50            | 46          | 0               | 1               | 35                     |
| 11      | 50            | 46          | 0               | 1               | 38                     |
| 12      | 50            | 46          | 0               | 1               | 47                     |
| 13      | 50            | 46          | 0               | 1               | 50                     |
| 14      | 50            | 46          | 0               | 1               | 33                     |
| 15      | 50            | 47          | 0               | 1               | 33                     |
| 16      | 49            | 45          | 0               | 2               | 50                     |
| TOTALS  | 799           | 740         | 0               | 17              | 740                    |

.....  
 CONNECTION TABLE  
 .....

| NODE | CONTIITY | NEIGHBOURS        |
|------|----------|-------------------|
| 1    | 6        | 2 4 5 9 13 14     |
| 2    | 6        | 1 3 6 7 14 15     |
| 3    | 6        | 2 4 7 15 16       |
| 4    | 6        | 1 3 5 8 13 16     |
| 5    | 6        | 1 4 6 8 9 12      |
| 6    | 6        | 1 2 5 7 9 10      |
| 7    | 6        | 2 3 6 10 11       |
| 8    | 6        | 3 4 5 7 11 12     |
| 9    | 6        | 5 6 10 13 14 15   |
| 10   | 6        | 6 7 8 10 12 15 16 |
| 11   | 6        | 6 7 8 10 12 15 16 |
| 12   | 6        | 6 7 8 10 12 15 16 |
| 13   | 6        | 1 4 9 12 13 15    |
| 14   | 6        | 1 2 9 12 13 15    |
| 15   | 6        | 2 3 10 11 14 16   |
| 16   | 6        | 3 4 11 12 13 15   |

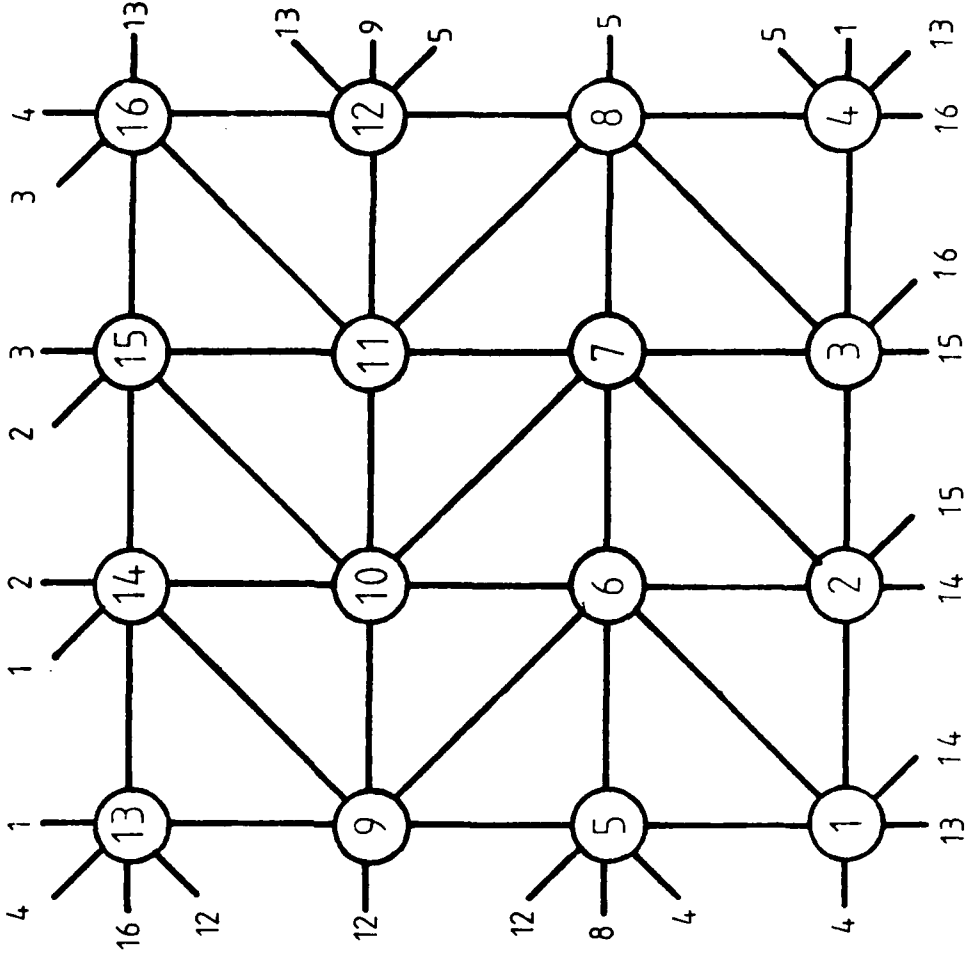

Figure 32

SIMULATED DURATION (seconds) = 2.16  
 AVERAGE DELAY TIME (microseconds) = 13410.9  
 TOTAL EXTERNAL TRAFFIC = 798  
 TOTAL HOST CONTENT = 17  
 MESSAGES IN COMMUNICATION SUBSYSTEM = 42  
 MESSAGES DELIVERED = 739  
 TOTAL DELIVERED BUT UNACKNOWLEDGED = 0  
 PERCENTAGE OF UNACKNOWLEDGED = 0.0

GLOBAL TRAFFIC STATISTICS IN NUMBER OF MESSAGES

| HOST ID | EXTERNAL INPUT | DELIVERED | UNACKNOWLEDGED | CURRENT CONTENT | RECEIVED MESSAGES |
|---------|----------------|-----------|----------------|-----------------|-------------------|
| 1       | 50             | 46        | 0              | 1               | 54                |
| 2       | 50             | 46        | 0              | 1               | 55                |
| 3       | 50             | 46        | 0              | 1               | 44                |
| 4       | 50             | 47        | 0              | 1               | 67                |
| 5       | 50             | 47        | 0              | 1               | 39                |
| 6       | 50             | 46        | 0              | 1               | 39                |
| 7       | 50             | 46        | 0              | 1               | 56                |
| 8       | 50             | 47        | 0              | 1               | 42                |
| 9       | 50             | 47        | 0              | 1               | 44                |
| 10      | 50             | 46        | 0              | 1               | 41                |
| 11      | 50             | 46        | 0              | 1               | 37                |
| 12      | 50             | 46        | 0              | 1               | 52                |
| 13      | 50             | 46        | 0              | 1               | 44                |
| 14      | 50             | 46        | 0              | 1               | 35                |
| 15      | 49             | 46        | 0              | 1               | 37                |
| 16      | 49             | 45        | 0              | 2               | 53                |
| TOTALS  | 798            | 739       | 0              | 17              | 739               |

CONNECTION TABLE

| NODE | CONTINITY | NEIGHBOURS             |
|------|-----------|------------------------|
| 1    | 8         | 2 4 5 6 8 13 14 16     |
| 2    | 8         | 1 3 5 6 7 8 13 14 15   |
| 3    | 8         | 2 4 6 7 8 14 15 16     |
| 4    | 8         | 1 3 5 7 8 13 15 16     |
| 5    | 8         | 1 2 4 6 8 9 10 12      |
| 6    | 8         | 1 2 3 5 7 9 10 11      |
| 7    | 8         | 2 3 4 6 8 10 11 12     |
| 8    | 6         | 1 3 4 5 7 9 11 12      |
| 9    | 8         | 5 6 8 10 11 13 14 15   |
| 10   | 8         | 5 6 7 8 10 12 14 15    |
| 11   | 8         | 6 7 8 10 12 14 15 16   |
| 12   | 8         | 5 6 7 8 9 11 13 14 16  |
| 13   | 8         | 1 2 4 5 10 12 14 15    |
| 14   | 8         | 1 2 3 9 10 11 12 14 16 |
| 15   | 8         | 2 3 4 10 11 12 14 16   |
| 16   | 8         | 1 3 4 9 11 12 13 15    |

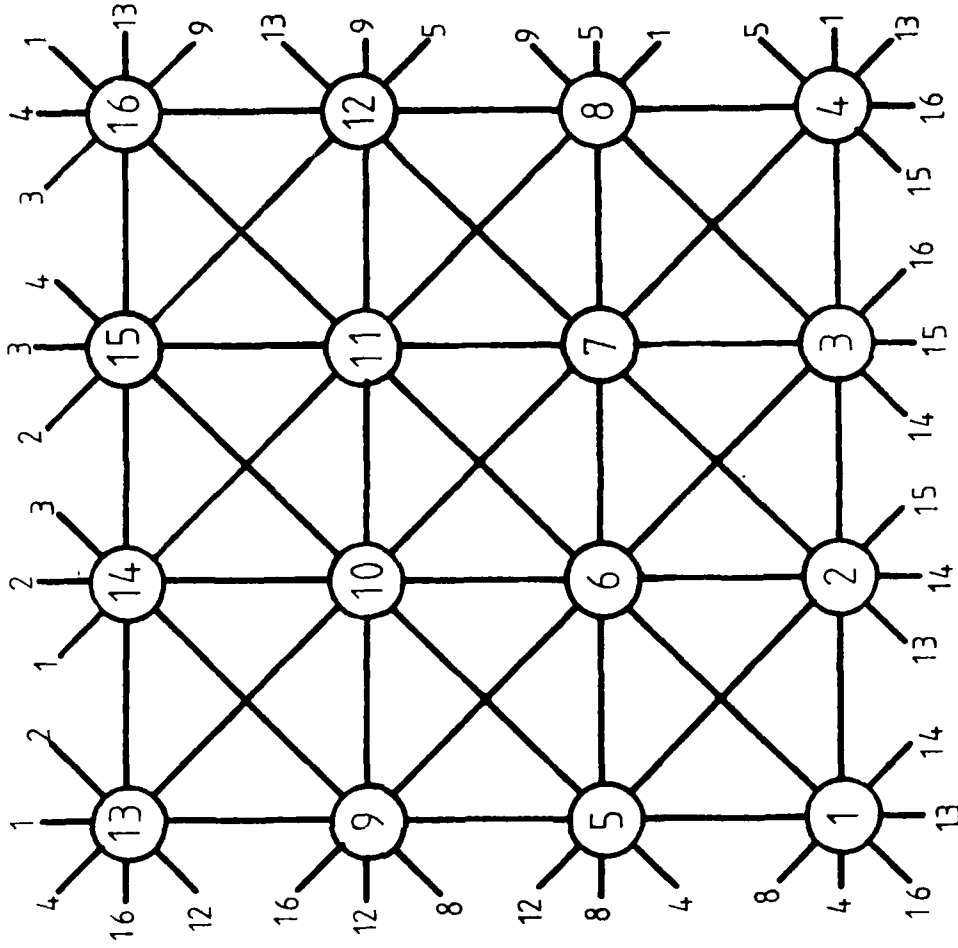

Figure 33

DATE  
FILMED  
2-8