

AD-A173 703

PHASE-SENSITIVE ULTRASONIC MODULATION OF PERSISTENT
SPECTRAL HOLES(U) IBM ALMADEN RESEARCH CENTER SAN JOSE
CA W E MOERNER ET AL 29 JAN 86 TR-4 N00014-84-C-0708

1/1

UNCLASSIFIED

F/G 14/5

NL



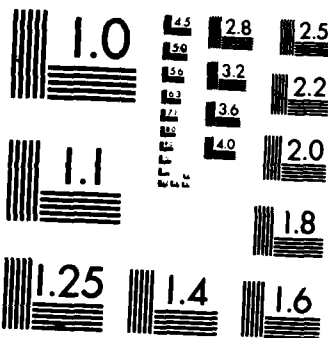

MICROCOPY RESOLUTION TEST CHART
NATIONAL BUREAU OF STANDARDS-1963-A

SECURITY CLASSIFICATION OF THIS PAGE

REPORT DOCUMENTATION PAGE

**DTIC
SELECTED
OCT 20 1986**

AD-A173 703

1a. REPORT SECURITY CLASSIFICATION Unclassified		1b. RESTRICTIVE MARKINGS	
2a. SECURITY CLASSIFICATION AUTHORITY		3. DISTRIBUTION/AVAILABILITY OF REPORT This document has been approved for public release and sale; its distribution is unlimited.	
2b. DECLASSIFICATION/DOWNGRADING SCHEDULE		5. MONITORING ORGANIZATION REPORT NUMBER(S)	
4. PERFORMING ORGANIZATION REPORT NUMBER(S) Technical Report No. 4, IBM RJ 5018			
6a. NAME OF PERFORMING ORGANIZATION IBM Almaden Research Center	6b. OFFICE SYMBOL (if applicable)	7a. NAME OF MONITORING ORGANIZATION Office of Naval Research Chemistry Division, Code 1113	
6c. ADDRESS (City, State, and ZIP Code) 650 Harry Road San Jose, CA 95120-6099		7b. ADDRESS (City, State, and ZIP Code) Arlington, VA 22217	
8a. NAME OF FUNDING/SPONSORING ORGANIZATION	8b. OFFICE SYMBOL (if applicable)	9. PROCUREMENT INSTRUMENT IDENTIFICATION NUMBER N00014-84-C-0708	
8c. ADDRESS (City, State, and ZIP Code)		10. SOURCE OF FUNDING NUMBERS	
		PROGRAM ELEMENT NO.	PROJECT NO.
		TASK NO.	WORK UNIT ACCESSION NO.
11. TITLE (Include Security Classification) Phase-Sensitive Ultrasonic Modulation of Persistent Spectral Holes			
12. PERSONAL AUTHOR(S) W. E. Moerner and A. L. Huston			
13a. TYPE OF REPORT Interim Technical	13b. TIME COVERED FROM _____ TO _____	14. DATE OF REPORT (Year, Month, Day) January 29, 1986	15. PAGE COUNT 15
16. SUPPLEMENTARY NOTATION <i>is presented</i>			
17. COSATI CODES		18. SUBJECT TERMS (Continue on reverse if necessary and identify by block number)	
FIELD	GROUP	SUB-GROUP	
		Persistent spectral hole-burning, ultrasonic modulation, uniaxial stress, shot-noise-limited detection.	
19. ABSTRACT (Continue on reverse if necessary and identify by block number) We present a new technique for the detection of spectral holes or other strain-sensitive spectral features using phase-sensitive ultrasonic modulation. The spectral feature is directly modulated at MHz rates in synchrony with an applied rf ultrasonic field, hence the method offers zero-background and the potential for high-speed detection with sensitivity near the quantum limit. The technique is demonstrated for a model color center system, and the characteristic lineshape is analyzed in detail. The method is more sensitive than laser FM (frequency modulation) spectroscopy for low modulation frequencies, and should be generally useful for the detection of strain-sensitive spectral features.			
20. DISTRIBUTION/AVAILABILITY OF ABSTRACT <input checked="" type="checkbox"/> UNCLASSIFIED/UNLIMITED <input type="checkbox"/> SAME AS RPT <input type="checkbox"/> DTIC USERS		21. ABSTRACT SECURITY CLASSIFICATION Unclassified	
22a. NAME OF RESPONSIBLE INDIVIDUAL		22b. TELEPHONE (Include Area Code)	22c. OFFICE SYMBOL

DTIC FILE COPY

OFFICE OF NAVAL RESEARCH

Contract N00014-84-C-0708

R&T Code 413a001---01

Technical Report No. 4

Phase-Sensitive Ultrasonic Modulation of Persistent Spectral Holes

by

W. E. Moerner and A. L. Huston

Prepared for Publication

in

Applied Physics Letters

**IBM Almaden Research Center
650 Harry Road
San Jose, California 95120-6099**

January 29, 1986

Reproduction in whole, or in part, is permitted for any purpose of the United States Government.

*** This document has been approved for public release and sale; its distribution is unlimited.**

**PHASE SENSITIVE DETECTION OF PERSISTENT SPECTRAL HOLES USING
SYNCHRONOUS ULTRASONIC MODULATION**

W. E. Moerner and A. L. Huston*

IBM Almaden Research Center
San Jose, California 95120-6099

ABSTRACT: We present a new technique for the detection of spectral holes or other strain-sensitive spectral features using phase-sensitive ultrasonic modulation. The spectral feature is directly modulated at MHz rates in synchrony with an applied rf ultrasonic field, hence the method offers zero-background and the potential for high-speed detection with sensitivity near the quantum limit. The technique is demonstrated for a model color center system, and the characteristic lineshape is analyzed in detail. The method is more sensitive than laser FM (frequency modulation) spectroscopy for low modulation frequencies, and should be generally useful for the detection of strain-sensitive spectral features.

*IBM Postdoctoral Fellow

Accession For	
NTIS CRA&I	<input checked="" type="checkbox"/>
DTIC TAB	<input type="checkbox"/>
Unannounced	<input type="checkbox"/>
Justification	
By	
Distribution/	
Availability Codes	
Dist	Avail and/or Special
A-1	



Spectral holes consist of narrow depressions or "dips" in the inhomogeneously broadened absorption lines of defect centers or impurities in solids at low temperatures. Persistent spectral hole formation, or "hole-burning", has been produced by photochemical processes in organic¹ and inorganic² systems as well as by nonphotochemical, or photophysical, mechanisms in glasses³ and crystals.⁴ In addition to providing important basic information about guest-light and guest-host interactions, persistent spectral holes may potentially be used to store digital data in a frequency domain optical storage system.⁵ Because holes burned on nanosecond time scales are usually shallow,⁶ high-sensitivity, high-speed methods for the observation of spectral holes are essential.

A variety of techniques are available for the detection of spectral holes including the standard methods of transmission spectroscopy and fluorescence excitation with narrow-band tunable lasers. These techniques suffer from the limitation that they do not have zero background, so that the detection of shallow holes is limited by the ability to accurately remove large baselines. Laser frequency modulation (FM) spectroscopy has been applied to the detection of spectral holes with zero background.⁷⁻⁹ Because the signal appears as amplitude modulation of a laser beam at MHz frequencies (i. e., away from the low-frequency power fluctuations of the laser), this method can show quantum-limited sensitivity.¹⁰ However, it requires an electro-optic modulator for the production of frequency modulated light with dye lasers. In addition, any optical elements in the beam with spectrally varying transmission can produce spurious background signals. Furthermore, residual amplitude modulation¹¹ hampers the application of FM spectroscopy in some cases, although dual-beam techniques¹² can be used to remove this limitation in some regimes.

Recently, ultrasonic modulation of nonphotochemical holes was reported as a new phase-insensitive optical detector for ultrasound in solids.¹³ In fact, ultrasonic modulation is a general interaction for inhomogeneously broadened transitions in low-temperature rigid matrices since it is just the strain-induced inequivalence that is the dominant source of inhomogeneous broadening. Ultrasound interacts with the optical absorption for each center causing the line to shift and/or split under the influence of the time-varying stress field. Using these ideas, we recently developed a new technique for the detection of spectral holes called HUMPH (for High-Resolution Ultrasonic Modulation of Persistent Holes), which utilizes the interaction between an ultrasonic field chopped at kHz rates and strain sensitive spectral features to produce amplitude modulation of a probing light beam.¹⁴ Contrary to FM spectroscopy and other external modulation schemes, *HUMPH directly modulates the effect under study*; hence it features zero-background and improved sensitivity. Furthermore, since the HUMPH signal is insensitive to the local ultrasonic phase, the position of the laser beam in the crystal and the relative sizes of the acoustic and optical wavelengths are unimportant. However, HUMPH suffers from the limitation that the maximum detection speed depends upon the rate at which the ultrasonic field is chopped and the decay time for ultrasound in the sample. The noise spectral density of many lasers at low frequencies (< 1 MHz) can be quite large, which limits the sensitivity of the method. In addition, for applications such as frequency domain optical storage, holes must be detected on submicrosecond time scales.

We report here a new technique for the detection of spectral holes that features direct modulation of spectral features in synchrony with the local ultrasonic field. We show that the resulting amplitude modulated light beam can be detected phase-sensitively

at the ultrasonic drive frequency, i.e. 1-100 MHz. The ability to detect in the MHz frequency range provides advantages similar to those of FM spectroscopy; in particular, at these frequencies most lasers have noise spectra that consist only of shot noise. We call this method PSHUMPH (for Phase Sensitive High-resolution Ultrasonic Modulation of Persistent Holes), and demonstrate the technique in a model system, the zero-phonon-line (ZPL) of F_3^+ centers in x-irradiated NaF.¹⁵ We present an analysis of the characteristic PSHUMPH lineshape (which differs dramatically from the phase-insensitive HUMPH lineshape) based on the interaction between the color center and uniaxial stress.^{16,17} We show that PSHUMPH can be more sensitive than FM spectroscopy for certain ranges of operating parameters, in particular, for rf modulation frequencies small compared to the width of the spectral feature. Thus, PSHUMPH is shown to be a high-sensitivity, zero-background, ultrasonic-phase-sensitive technique that should be generally applicable to all strain-sensitive absorption features.

The sample, single frequency dye laser, optical arrangement, and method of bonding an 8 MHz ultrasonic transducer to the sample were identical to those used in the phase-insensitive HUMPH experiments;¹⁴ however, certain experimental conditions bear repeating here. Spectral holes were burned in the 545 nm F_3^+ ZPL in a crystal of x-irradiated NaF immersed in superfluid helium (1.6 K). Laser powers near 1-2 mW were used to burn the holes, and powers 1000 times smaller were utilized for hole detection. The laser beam was focused to a spot size of approximately 0.1mm in the sample. It was essential for the observation of the phase-sensitive effect that the laser spot size be less than one-half the acoustic wavelength (for NaF at 8 MHz the acoustic wavelength is 760 μ m). The spectral holes had widths approximately 200 MHz FWHM¹⁸

and depths corresponding to a 5-7 % change in the sample transmission at the center of the ZPL. The line-center transmission of the ZPL before burning was roughly 10 %.

A schematic of the detection apparatus is shown in Figure 1. Ignoring the rf switch for a moment, the x-cut quartz transducer was driven at its 8 MHz fundamental by a rf signal from a standard sine-wave oscillator. Transducer drive levels near 20 dBm were used to generate low energy ultrasonic fields in order to prevent partial erasing and broadening of the holes.^{13,14} No special matching of the rf transmission line to the transducer was necessary. To force the laser beam to interact with a region of the sample with well-defined ultrasonic phase, the laser beam was aligned parallel to the ultrasonic phase fronts. Due to the high Q of our sample and the presence of multiple reflections, the phase-sensitive signal was strongest just after the initial application of the rf drive voltage to the transducer, and smaller after one round-trip time of the ultrasound had elapsed (roughly 2 μ sec). This was due to a buildup of incoherent ultrasound with ill-defined phase as described in earlier experiments.^{13,14} Accordingly, the rf drive signal was gated at a 10 kHz rate at a 10% duty cycle, and a boxcar (5 μ s aperture duration, 1 ms output time constant) was used to sample the 8 MHz modulation soon after the start of the ultrasonic pulse. We emphasize that PSHUMPH signals could also be observed with cw ultrasound, but due to our sample configuration, these signals were smaller. A sample geometry with acoustic termination of the side of the sample away from the transducer would prevent ultrasonic reflections and remove this limitation.

The amplitude modulated, transmitted laser beam was detected with a high-speed avalanche photodiode equipped with a built-in low-noise preamplifier. Demodulation of the signal was accomplished with a double-balanced mixer, with the local oscillator being driven at the same frequency, 8 MHz, as the ultrasound. The output of the boxcar was

processed with a signal averager set to average 32 scans of the laser frequency, each of 0.25 s duration.

Laser FM spectroscopy⁷⁻¹⁰ was also used to detect the spectral holes, in order to directly compare the two techniques. The detection arrangement and electronics were exactly the same as that for the PSHUMPH measurements except that a phase modulator driven at frequencies $\omega_{FM} = 8 - 100$ MHz was used to modulate the light beam and ultrasound was not applied to the sample. The intensities of the FM sidebands were approximately 1% of the carrier intensity.

Figure 2 demonstrates the lineshape and the phase sensitivity of the PSHUMPH method. The signal appears on zero background, and has a characteristic lineshape similar to the first derivative of a Lorentzian. In Figure 2a, the phase relationship between the ultrasonic field and the local oscillator was adjusted to give the maximum signal, and in Figure 2b the phase was shifted by 180 degrees. Similar inversions of sign were observed when the laser beam was translated one-half an acoustic wavelength in a direction parallel to the acoustic propagation vector. No signal was observed in the quadrature phase. This PSHUMPH lineshape is quite different from the phase-insensitive HUMPH lineshape.¹⁴

Figure 3 shows a comparison of hole detection using PSHUMPH and using FM spectroscopy. In Figure 3a, FM with $\omega_{FM} = 50$ MHz was used to measure a spectral hole. Figure 3b shows an attempt to detect the same hole with $\omega_{FM} = 8$ MHz; the FM signal is not observable. Figure 3c shows a trace of the hole using PSHUMPH driven at 8 MHz. (The apparent inversion in sign between the FM and PSHUMPH signals shown in the figure has no significance.) The absence of the FM signal when $\omega_{FM} = 8$ MHz is a

consequence of the fact that for hole widths larger than the sideband spacing, the amplitude of the FM signal depends linearly upon the sideband frequency. The PSHUMPH signal, however, depends upon the strength of the ultrasonic field and the sensitivity of the centers to ultrasonic fields. Thus in certain regimes, particularly when the spectral feature is broader than the modulation frequency, PSHUMPH can produce larger signals than FM spectroscopy.

The background noise level for all the traces in Figure 3 does not represent laser shot noise. This is a consequence of the low ($1 \mu\text{W}$) laser power required to read the holes without distortion of the hole lineshape by the reading laser. With an overall sample transmission of 10 %, the light power level at the detector was only $0.1 \mu\text{W}$, and this level was insufficient to have laser shot noise dominate the Johnson noise of the detector-preamplifier system. At reading laser powers only 10 times higher, the noise levels for both the FM and PSHUMPH methods (at equal modulation frequencies) were equal and dominated by laser shot noise. Thus, for samples that can tolerate higher reading powers, we expect that PSHUMPH should approach quantum-limited sensitivity in a manner similar to FM spectroscopy.⁹⁻¹²

The results from static uniaxial stress studies on the inhomogeneous line of the F_3^+ center in NaF ^{16,17} can be used to model the PSHUMPH lineshape. The propagation of (longitudinal) ultrasonic waves through the crystal causes a periodic variation of the density of the material resulting from alternating regions of compression and rarefaction. Uniaxial stress causes the absorption from a given class of centers to both shift in energy and split into a number of components due to removal of the electronic degeneracy of the excited state. For the experiments described in this paper, longitudinal stress was applied in the [100] direction and the probing light was polarized along [010]. Under these

conditions, the zero phonon line splits into two components, both shifting linearly to higher energy for compression and lower energy for rarefaction.

The stress fields generated in the sample by the low power ultrasound utilized here were insufficient to completely split the absorption line into separated sidebands. However, the oscillating ultrasonic field does cause the spectral hole to broaden and oscillate about the burn energy, producing amplitude modulation of the light beam at the ultrasonic drive frequency whenever the light beam wavelength is close to the spectral feature. Thus, the PSHUMPH signal has zero background since modulation of the transmitted light can only occur when the light is in near resonance with the hole. We take for the lineshape of the spectral hole a Lorentzian function in the form:

$L(\nu) = (2/\pi\Delta\nu)\{1 + [\nu/(\Delta\nu/2)]^2\}^{-1}$ where ν is the laser frequency, $\Delta\nu$ is the full width at half maximum, and the burn frequency is at $\nu=0$. In the presence of an ultrasonic field, the absorption lineshape function can be described by two oscillating Lorentzian functions:

$$U(\nu, t, \phi) \sim g_1 \left\{ 1 + \left[\frac{\nu - \alpha \sin(\Omega t + \phi)}{\Delta\nu/2} \right]^2 \right\}^{-1} + g_2 \left\{ 1 + \left[\frac{\nu - \beta \sin(\Omega t + \phi)}{\Delta\nu/2} \right]^2 \right\}^{-1} \quad (1)$$

Each of the two components has a center frequency that oscillates as $\sin(\Omega t + \phi)$ where Ω is the frequency of the ultrasound and ϕ is the phase relative to the local oscillator. The factors α and β determine the magnitude of the maximum shift from the burn frequency for the two components. These two parameters are linearly proportional to the strength of the ultrasonic field and their ratio, β/α , is determined by the uniaxial stress interaction¹⁶ to be 0.283. g_1 and g_2 represent the relative absorption strengths of the two components and are in the ratio $g_1:g_2=1:3$.

The signal at the detector output consists of a dc component and a time-varying component proportional to the amplitude modulation of the transmitted light beam, $\exp[-U(\nu, t, \phi)]$. The (dc) output of the mixer, $H(\nu, \phi)$, is proportional to the average value of the product of the detector current and the local oscillator reference signal:

$$H(\nu, \phi) = C \langle \exp [- U(\nu, t, \phi)] \sin (\Omega t) \rangle \quad (2)$$

where C is a proportionality constant and $\langle \rangle$ represents the time average. A simulation of the observed lineshape using Equation 2 with the local oscillator in phase with respect to the phase of the ultrasonic field ($\phi = 0$) is shown in Figure 4. For this fit, the hole width $\Delta\nu$ was set at the measured value of 200 MHz, and the two fitting parameters were the overall multiplicative calibration of the signal and the factor representing the strength of the ultrasonic field, $\alpha = 150$ MHz. The fit is excellent, and we may conclude that the interaction of the burned centers with a time-varying uniaxial stress accounts well for the observed PSHUMPH lineshape. Centers that have different uniaxial stress splittings would show correspondingly different lineshapes.

Since PSHUMPH allows detection of holes in the frequency region where most lasers show only shot noise power fluctuations, this method should approach the quantum limit of sensitivity for reading powers sufficient to overcome Johnson noise of the detector. With lasers capable of scanning at high speeds, hole detection should be possible in times near the period of the ultrasonic wave itself. Because PSHUMPH has the desirable property of direct modulation of only the effect under study, it is free from background signals and should be generally applicable to all strain-sensitive spectral features. Furthermore, double-modulation detection using both PSHUMPH and FM

would be expected to be a particularly powerful combination of internal and external modulation methods that overcomes problems like residual AM, for example.

REFERENCES

This work was supported in part by the U. S. Office of Naval Research.

1. L. A. Rebane, A. A. Gorokhovskii, and J. V. Kikas, *Appl. Phys.* B29, 235 (1982).
2. R. M. Macfarlane, R. T. Harley and R. M. Shelby, *Radiation Effects* 72, 1 (1983).
3. G. J. Small, in Spectroscopy and Excitation Dynamics of Condensed Molecular Systems, V. M. Agranovitch and R. M. Hochstrasser, editors (North-Holland, Amsterdam, 1983), pp. 515-554.
4. W. E. Moerner, A. R. Chraplyvy, A. J. Sievers, and R. H. Silsbee, *Phys. Rev.* B28, 7244 (1983).
5. G. Castro, D. Haarer, R. M. Macfarlane, and H. P. Trommsdorff, U. S. Patent No. 4,101,976 (1978); W. E. Moerner, *J. Molec. Elec.* 1, 55 (1985).
6. M. Romagnoli, W. E. Moerner, F. M. Schellenberg, M. D. Levenson, and G. C. Bjorklund, *J. Opt. Soc. Amer. B* 1, 341 (1984).
7. G. C. Bjorklund, *Opt. Lett.* 5, 15 (1980); W. Lenth, C. Ortiz, and G. C. Bjorklund, *Opt. Lett.* 6, 351 (1981).
8. W. E. Moerner, F. M. Schellenberg, and G. C. Bjorklund, *Appl. Phys.* B28, 263 (1982).
9. G. C. Bjorklund, M. D. Levenson, W. Lenth, and C. Ortiz, *Appl. Phys.* B32, 145 (1983).
10. M. D. Levenson, W. E. Moerner, and D. E. Horne, *Opt. Lett.* 8, 108 (1983).
11. E. A. Whittaker, M. Gehrtz, and G. C. Bjorklund, *J. Opt. Soc. Am.* B2, 1320 (1985).
12. M. Gehrtz, G. C. Bjorklund, and E. A. Whittaker, *J. Opt. Soc. Am.* B2, 1510 (1985).

13. D. H. Lengfellner, T. R. Gosnell, R. W. Tkach, and A. J. Sievers, *Appl. Phys. Lett.* 43, 437 (1983).
14. A. L. Huston and W. E. Moerner, *J. Opt. Soc. Amer. B* 1, 349 (1984).
15. R.M. Macfarlane and R.M. Shelby, *Phys. Rev. Lett.* 42, 788 (1979).
16. G. Baumann, F. Lanzl, W. von der Osten, and W. Waidelich, *Z. Phys.* 197, 367 (1966).
17. G. Johansson, W. von der Osten, R. Piehl, and W. Waidlich, *Phys. Stat. Sol.* 34, 699 (1969).
18. These widths are broader than twice the homogeneous linewidth, 2×17 MHz,¹⁵ because of the small spot sizes and consequent high power densities used to burn the holes.

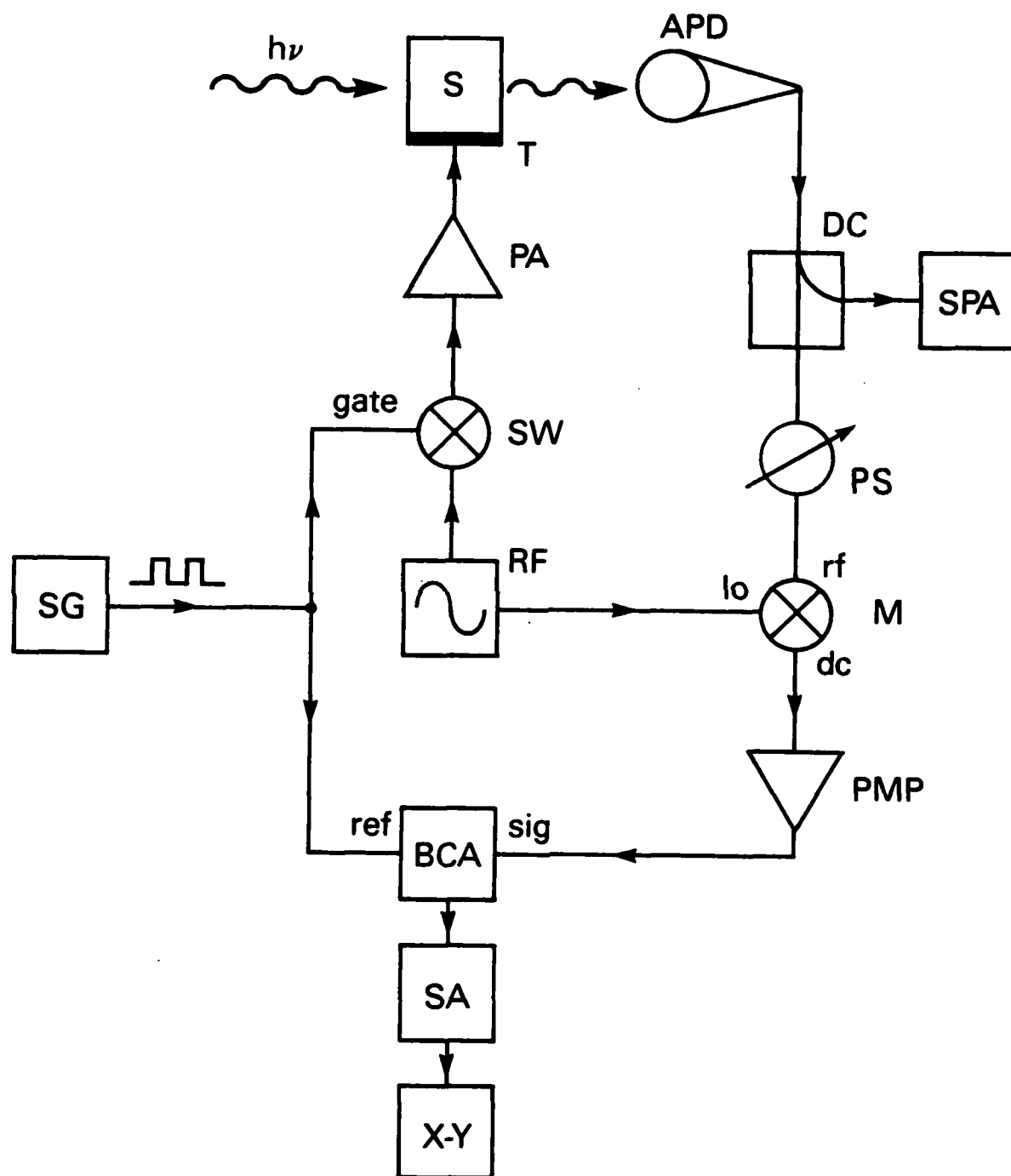

Figure 1. Experimental arrangement for PSHUMPH. Legend: SG-signal generator; RF-rf oscillator; SW-rf switch; PA-rf power amplifier; T-transducer; S-sample in liquid helium cryostat; APD- avalanche photodiode; DC-directional coupler; SPA-spectrum analyzer for diagnostics; PS-phase shifter; M-mixer with rf, lo, and dc ports; PMP-post mixer preamp; BCA-boxcar averager; SA-signal averager; X-Y-x-y recorder.

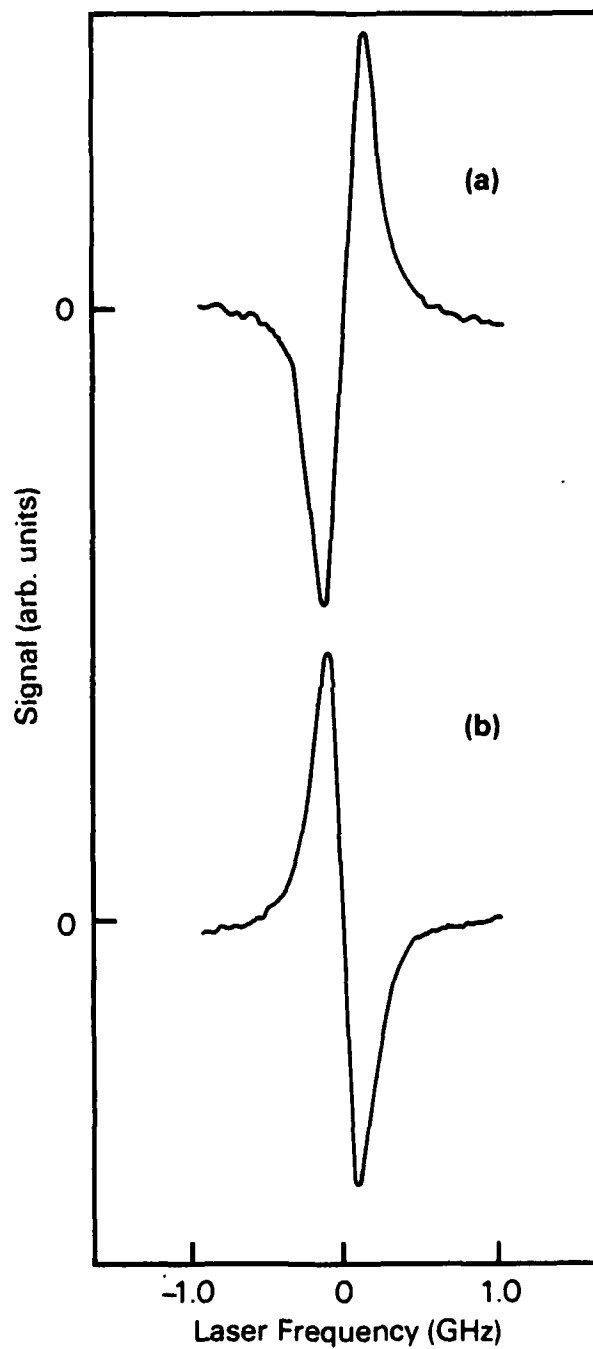

Figure 2. Traces of a hole measured using PSHUMPH showing sensitivity to the ultrasonic phase. a) Phase arbitrarily set at zero, b) phase shifter offset by 180 degrees. The ultrasonic field was driven at 8.2 MHz with an rf power of 125 mW. This hole was burned near the edge of the ZPL absorption.

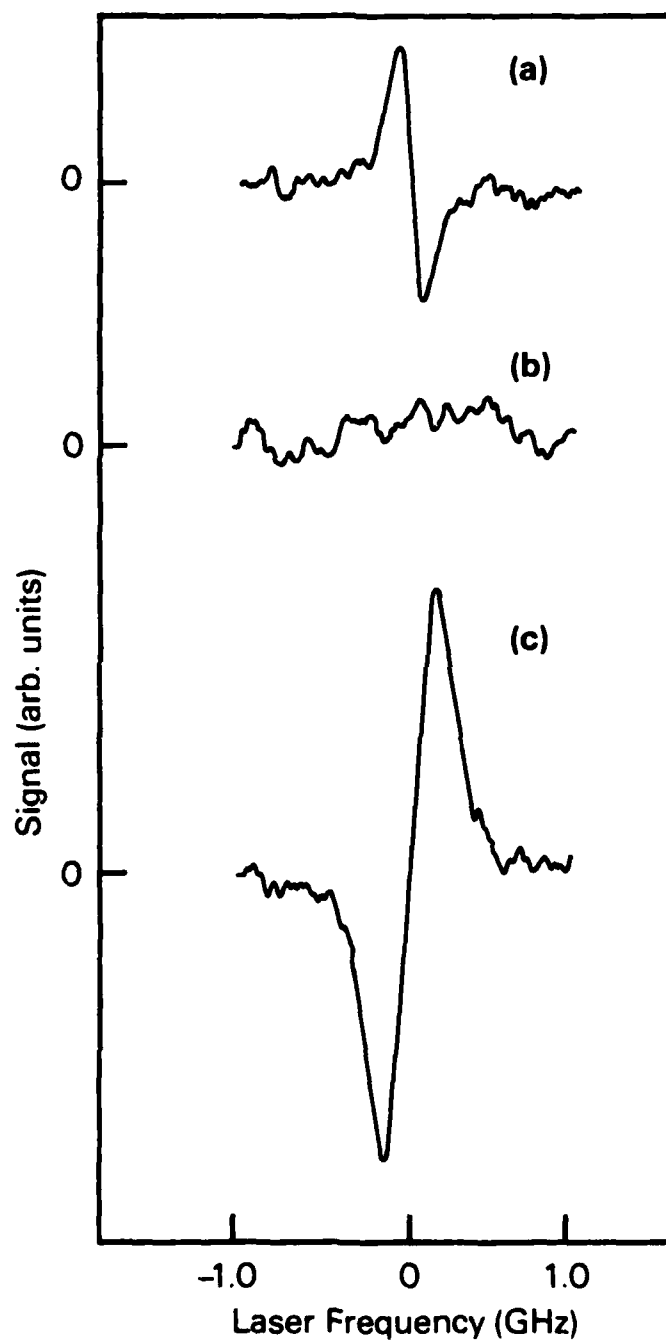

Figure 3. A comparison of spectral hole detection using FM spectroscopy and PSHUMPH. This hole was burned near the center of the ZPL with a laser power of 1 mW for 1 s. The traces represent: a) FM spectroscopy at 50 MHz, b) FM spectroscopy at 8 MHz, c) PSHUMPH at 8 MHz. All three traces have the same vertical scale. The ultrasonic field was generated with an rf power of 63 mW.

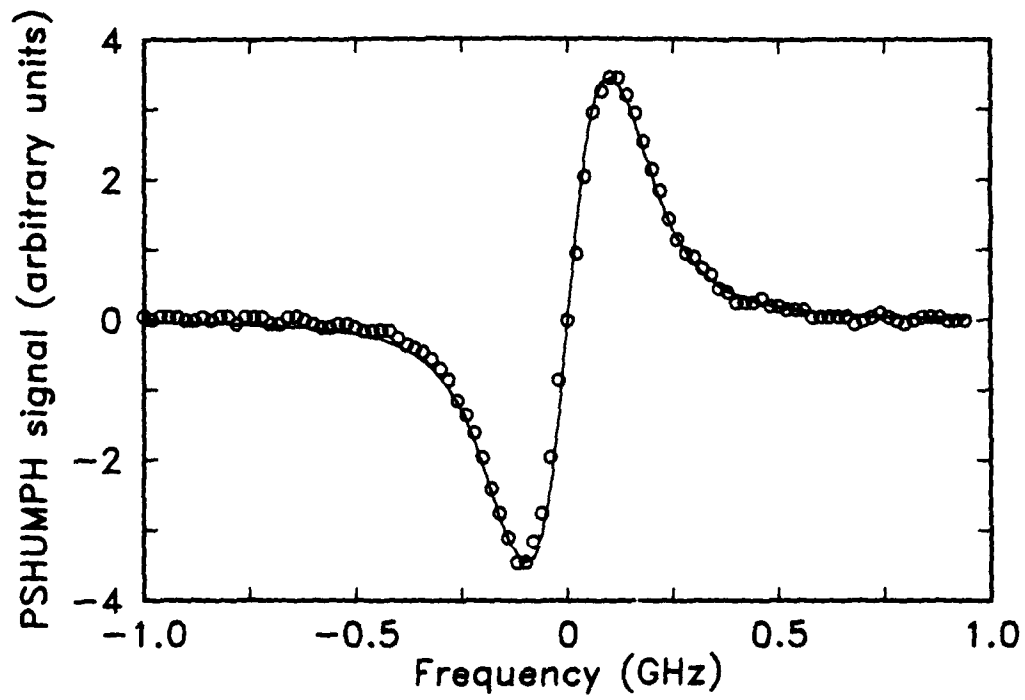

Figure 4. Computer simulation of the PSHUMPH lineshape using equation 2 (solid curve) along with experimental data points (circles). The parameters used in the fit were $\Delta\nu = 200$ MHz and $\alpha = 150$ MHz.

TECHNICAL REPORT DISTRIBUTION LIST, GEN

	<u>No. Copies</u>		<u>No. Copies</u>
Office of Naval Research Attn: Code 1113 800 N. Quincy Street Arlington, Virginia 22217-5000	2	Dr. David Young Code 334 NORDA NSTL, Mississippi 39529	1
Dr. Bernard Douda Naval Weapons Support Center Code 50C Crane, Indiana 47522-5050	1	Naval Weapons Center Attn: Dr. Ron Atkins Chemistry Division China Lake, California 93555	1
Naval Civil Engineering Laboratory Attn: Dr. R. W. Drisko, Code L52 Port Hueneme, California 93401	1	Scientific Advisor Commandant of the Marine Corps Code RD-1 Washington, D.C. 20380	1
Defense Technical Information Center Building 5, Cameron Station Alexandria, Virginia 22314	12 high quality	U.S. Army Research Office Attn: CRD-AA-IP P.O. Box 12211 Research Triangle Park, NC 27709	1
DTNSRDC Attn: Dr. H. Singerman Applied Chemistry Division Annapolis, Maryland 21401	1	Mr. John Boyle Materials Branch Naval Ship Engineering Center Philadelphia, Pennsylvania 19112	1
Dr. William Tolles Superintendent Chemistry Division, Code 6100 Naval Research Laboratory Washington, D.C. 20375-5000	1	Naval Ocean Systems Center Attn: Dr. S. Yamamoto Marine Sciences Division San Diego, California 91232	1

END

12-86

DTIC