

AD-A173 847

STUDIES FOR DEVELOPMENT OF A PLASTIC COMPRESSION  
IGNITION FUZE FOR 81 MM (U) MATERIALS RESEARCH LABS  
ASCOT VALE (AUSTRALIA) R J SPEAR ET AL APR 86

1/1

UNCLASSIFIED

MRL-R-993

F/G 19/1

NL

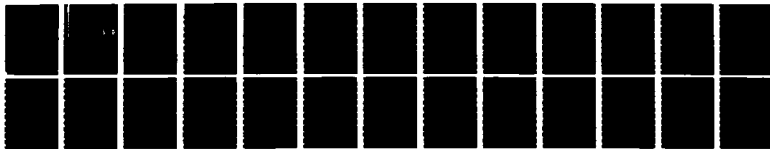

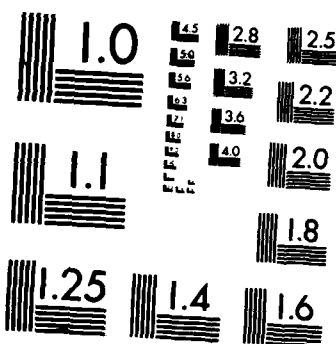

XEROCOPY RESOLUTION TEST CHART  
NATIONAL BUREAU OF STANDARDS-1963-A

12



**DEPARTMENT OF DEFENCE**  
**DEFENCE SCIENCE AND TECHNOLOGY ORGANISATION**  
**MATERIALS RESEARCH LABORATORIES**  
**MELBOURNE, VICTORIA**

AD-A173 847

**REPORT**  
**MRL-R-993**

**DTIC**  
**ELECTE**  
NOV 10 1988  
**S** **D**

**STUDIES FOR DEVELOPMENT OF A PLASTIC COMPRESSION**  
**IGNITION FUZE FOR 81 MM MORTAR PRACTICE AMMUNITION**

**R.J. Spear, L.D. Redman, L. de Yong**  
**and G.D. Holt**

THE UNITED STATES NATIONAL  
TECHNICAL INFORMATION SERVICE  
IS AUTHORIZED TO  
REPRODUCE AND SELL THIS REPORT

Approved for Public Release



APRIL 1986

DTIC FILE COPY

DEPARTMENT OF DEFENCE  
MATERIALS RESEARCH LABORATORIES

REPORT

MRL-R-993

STUDIES FOR DEVELOPMENT OF A PLASTIC COMPRESSION  
IGNITION FUZE FOR 81 MM MORTAR PRACTICE AMMUNITION

R.J. Spear, L.D. Redman, L. de Yong  
and G.D. Holt

ABSTRACT

The results of investigations conducted during 1985 on development of a plastic compression ignition (CI) fuze are described. Sensitivity and performance of both HE and pyrotechnic filled CI initiators are described, and suitable materials identified. Developmental work has been on RDX grade A filled initiators. The use of silicone rubber caps has partially overcome the desensitization upon thermal cycling observed in Fuze F7. Fuzes consisting of plastic components with an aluminium initiator have been successfully field tested. Initiators moulded from glass-filled noryl are not satisfactory and further plastics must be investigated in 1986. Other areas of study to finalise the project in 1986 are outlined.



Approved for Public Release

Accession For	
NTIS CRA&I	<input checked="" type="checkbox"/>
DTIC TAB	<input type="checkbox"/>
Unannounced	<input type="checkbox"/>
Justification .....	
By .....	
Distribution/ .....	
Availability Codes	
Dist	Avail and/or Special
A-1	

POSTAL ADDRESS: Director, Materials Research Laboratories  
P.O. Box 50, Ascot Vale, Victoria 3032, Australia

## DOCUMENT CONTROL DATA SHEET

REPORT NO. MRL-R-993	AR NO. AR-004-433	REPORT SECURITY CLASSIFICATION Unclassified
-------------------------	----------------------	--

## TITLE

Studies for development of a plastic compression  
ignition fuze for 81 mm mortar practice ammunition

## AUTHOR(S)

R.J. Spear, L.D. Redman, L. de Yong, G.D. Holt

## CORPORATE AUTHOR

Materials Research Laboratories  
P.O. Box 50,  
Ascot Vale, Victoria 3032

REPORT DATE  
April, 1986

TASK NO.  
ARM 85/160

SPONSOR  
ARMY

FILE NO.  
G6/4/8-3154

REFERENCES  
29

PAGES  
25

## CLASSIFICATION/LIMITATION REVIEW DATE

CLASSIFICATION/RELEASE AUTHORITY  
Superintendent, MRL  
Physical Chemistry Division

## SECONDARY DISTRIBUTION

Approved for Public Release

## ANNOUNCEMENT

Announcement of this report is unlimited.

## KEYWORDS

Compression Ignition Fuzes  
Practice ammunition

Initiators

COSATI GROUPS 19010

## ABSTRACT

The results of investigations conducted during 1985 on development of a plastic compression ignition (CI) fuze are described. Sensitivity and performance of both HE and pyrotechnic filled CI initiators are described, and suitable materials identified. Developmental work has been on RDX grade A filled initiators. The use of silicone rubber caps has partially overcome the desensitization upon thermal cycling observed in Fuze F7. Fuzes consisting of plastic components with an aluminium initiator have been successfully field tested. Initiators moulded from glass-filled noryl are not satisfactory and further plastics must be investigated in 1986. Other areas of study to finalise the project in 1986 are outlined.

## CONTENTS

	<u>Page No.</u>
1. INTRODUCTION	1
2. EXPERIMENTAL	2
2.1 Filling Compositions	2
2.1.1 High Explosive (HE) Compositions	2
2.1.2 Pyrotechnic Compositions	2
2.2 Material Characterisations	4
2.2.1 Particle Size Measurements	4
2.2.2 Temperature of Ignition (T of I)	4
2.2.3 Differential Scanning Calorimetry (DSC)	4
2.2.4 Rotter Impact Sensitivity (F of I)	4
2.2.5 Glancing Blow Test	5
2.3 Initiator Components	5
2.3.1 Initiator Bodies	5
2.3.2 Rubber Cap	5
2.3.3 Metal Cup	5
2.4 Preparation of Filled Initiators	6
2.4.1 High Explosive Fillings	6
2.4.2 Pyrotechnic Fillings	6
2.4.3 Filling of Plastic Initiators	7
2.4.4 Fitting of Rubber Cap/Metal Cup	7
2.5 Static Sensitivity Testing of Initiators and Components	7
2.5.1 Testing of Initiators	7
2.5.2 Testing of Plastic Initiating Plug	7
3. RESULTS AND DISCUSSION	7
3.1 Sensitivity of HE Filled Initiators	8
3.2 Pyrotechnic Fillings	10
3.3 Desensitization of Initiators Upon Climatic Cycling	11
3.4 Assessment of Plastic Components	13
4. CONCLUSION	14
5. ACKNOWLEDGEMENTS	15
6. REFERENCES	16

STUDIES FOR DEVELOPMENT OF A PLASTIC COMPRESSION  
IGNITION FUZE FOR 81 MM MORTAR PRACTICE AMMUNITION

1. INTRODUCTION

The increasing cost of ammunition has resulted in inability of the Services to meet requirements for training within current budgetary constraints. One solution to this problem would be to develop low cost training ammunition for high usage items, using the savings generated to finance training with low usage high cost rounds. Following consultation with Army, it was decided in the latter half of 1984 to commence a project at MRL aimed at developing a low cost, low lethality practice round for 81 mm mortar.

A major cost in most service rounds is the fuze, thus considerable savings in total cost would be generated by developing a cheap fuze. One option pursued within the Fuzes Research Group at MRL was to re-examine the Fuze F7 which was developed during the 1950s and 1960s at MRL. A diagram of the F7 is shown in Fig. 1. Fuze F7 functions by compression ignition (CI) and has a number of attractive features:

1. it contains many fewer parts than a conventional out-of-line safe-arming fuze, leading to large cost savings in manufacture and inspection, and
2. it contains no primary explosive, thus is comparatively safe to manufacture and handle, has longer shelf-life, and does not form sensitive compounds with other parts of the fuze with subsequent danger of premature function in storage and handling.

In addition, moulding most of the fuze components in plastic should be readily achievable thereby leading to further cost savings.

Fuze F7 was accepted for use in the Australian Army and was used in HE filled training ammunition for 81 mm mortar from the late 1960s to mid 1970s. The major reason given for discontinuing use of Fuze F7 was that it

produced excessive "blinds" during service use [1]. This poor performance apparently occurred over a range of target types. The lack of safe arming does not seem to have been a factor in discontinuing service use.

Introduction of a redeveloped CI fuze to service use therefore depended on demonstration that the problems experienced by Fuze F7 had been overcome. The first stage of this project was to conduct an exhaustive survey of published and unpublished data originating from the development of Fuze F7, and this has been completed and published [2]. Two major problem areas where substantial performance improvement could be achieved were identified in this survey:

1. nose design of the fuze, probably the major factor leading to the high incidence of "blinds", and
2. desensitization resulting from climatic storage

The work undertaken on the CI fuze in the twelve months to the end of December 1985 is described in this report. The areas covered include examination of both HE and pyrotechnic fillings in the initiator, desensitization on climatic cycling with respect to eliminating or minimising this effect, and evaluation of plastic components.

## 2. EXPERIMENTAL

### 2.1 Filling Compositions

#### 2.1.1 High Explosive (HE) Compositions

RDX grade A and grade E, HMX, PETN (ICI) and tetryl were commercial materials obtained from stocks held at MRL. RDX-polyethylene wax (95:5) was prepared at MRL, as part of another project, from RDX grade A and AC629 polyethylene wax [3]. The exact ratios were RDX (94.6%), polyethylene wax (5.4%). PETN K13 was material prepared previously at MRL by precipitation of ICI PETN from acetone-water.

#### 2.1.2 Pyrotechnic Compositions

The complete compositions of the pyrotechnics studied in the project are given in Table 1, and reference below is only to their composition number.

G40 and SFG40 were commercial samples obtained from Explosives Factory Maribyrnong (EFM). Individual components for all other compositions were dried and sized before mixing. They were all consistent with specifications, with the single exception of SR46(MOD) where zirconium/nickel powder was substituted for zirconium powder. Descriptions of composition preparations are generally brief because they differ little from the literature preparations. All compositions were dried after mixing.

SR112 [4]

The ingredients were mixed in an end runner mill with methylated spirits, then sieve sized.

RD1362(HD) (5% boron)

A suspension of washed boron (10 g) in sodium hydroxide (6.4 g) in water (1.2 L) was heated to 90°C with stirring. Solutions of 0.8 M lead nitrate (1.06 L) and 1.6 M sodium hydroxide (1.06 L) were added slowly over 60 minutes. After addition, the product was filtered off and allowed to dry.

SR399 [4]

The magnesium was coated with acroid resin, dried, then sieve mixed with the barium peroxide.

SR371A and SR371C [5]

The magnesium was coated with acroid resin, dried, then sieve mixed with potassium nitrate.

SR252 [4]

Preparation was the same as SR399 except that the sample was granulated with gum arabic after mixing.

SR189 [6]

Mixed in an identical manner to SR112.

SR24(MOD) [7]

The ingredients were hand mixed with methylated spirits and then sieve sized.

SR136 [8]

The ingredients were mixed by passing 4 x BSS 25 sieve.

## MRL(X)409

Potassium perchlorate (< 125  $\mu\text{m}$ ) and potassium benzoate were sieve mixed 4 x BSS 25 sieve. A solution of Dow Corning D1400 high vacuum grease (1 g) in toluene (10 mL) was added and the product mixed by hand then passed through a BSS 10 sieve. The mixing and sieving were repeated and the product was finally dried at 90°C.

### 2.2 Material Characterisations

#### 2.2.1 Particle Size Measurements

Particle sizes were determined using a Malvern Particle Size Analyser Model 2600/3600. The samples were measured while suspended in a solvent such as water or hexane where solubility of the explosive was very low.

#### 2.2.2 Temperature of Ignition (T of I)

Ignition temperatures were determined on an instrument built to specifications for the ERDE temperature of ignition test. Unconfined 50 mg samples were heated at 5°Cmin<sup>-1</sup> in test tubes, the temperature of ignition being that temperature at which the samples ignited to explosion or fast burn. Measurements were performed in triplicate and results were reproducible to within 1°C.

#### 2.2.3 Differential Scanning Calorimetry (DSC)

Thermochemical measurements were obtained using a Perkin-Elmer DSC-2 differential scanning calorimeter fitted with a Scanning Auto-Zero (SAZ) accessory. The sample of about 1 mg was accurately weighed on a Mettler ME30 microbalance directly into aluminium sample pans, then the lids were placed (not crimped) on the samples. The sample and reference compartments of the calorimeter were continuously purged with nitrogen gas throughout the DSC scans, which were carried out at heating rate of 5°Cmin<sup>-1</sup> over the temperature range 320° to 620°C. The nitrogen flow rate was typically 20-25 mLmin<sup>-1</sup>. The output was calibrated using samples of indium (m.p. 429.7 K) and tin (m.p. 505.1 K).

#### 2.2.4 Rotter Impact Sensitivity (F of I)

Impact sensitivity was determined on a Rotter Apparatus [9]. Samples of approximately 27 mg were tested with a 5 kg weight using the standard Bruceton staircase procedure [10]. A total of 50 caps were tested, the F of I being the figure relative to RDX=80 at which probability for ignition was 50%.

### 2.2.5 Glancing Blow Test

The test apparatus is based on an original ICI (Ardeer) test method which was modified at MRL. In this test the explosive/pyrotechnic sample is spread on a flat surface. A moving torpedo-shaped anvil with a spherical surface is then released to slide down an incline and impact the sample. The height of drop and weight of anvil are varied to give a range of energies. The test is repeated for various energy levels until O/10 fires occur at a particular level. The energy above this level is taken as the minimum ignition energy. In this study only the pyrotechnic samples were tested, and only tested with steel anvils on steel plates. The maximum test energy was 11.0 J.

## 2.3 Initiator Components

### 2.3.1 Initiator Bodies

Anodized aluminium XF2 Initiator Moulds (bodies) [11] remaining from the Fuze F7 project were used without alteration. Plastic initiator bodies were prepared by injection moulding at EFM. The material was 40% glass-filled Noryl GFN3 supplied by General Electric.

### 2.3.2 Rubber Cap

Three types of rubber cap were available. All were of the hemispherical design. In the early stages of the project a bag of several thousand neoprene A35 caps remaining from production was found at EFM. These were tested and found satisfactory, but since loss of volatile components may have occurred a new batch was prepared according to the original specification DSL 300E [12] except that RSS No. 1 was replaced by SRM GP due to availability problems, while phenyl- $\beta$ -naphthylamine was replaced by octylated diphenylamine. Cure was as described in [12].

The silicone rubber caps were prepared from MRL 1457 [13] which consisted of silastic HS30 (100.0) and dicup R (0.45) which was cured as for the neoprene then post-cured to remove acetophenone. The silicone rubber tested in Fuze F7 was Silastic S6508 [14].

All preparation and testing of rubber caps was carried out by Mr T.E. Symes of the Elastomers and Plastics Group, OCD, MRL.

### 2.3.3 Metal Cup

Metal cups were made at Ammunition Factory Footscray (AFF) to the original drawing (TSE(X)459-5/1) by impact extrusion of aluminium alloy 1200 followed by conditioning to the required hardness.

## 2.4 Preparation of Filled Initiators

Because the filling procedure used for initiator XF2 was not described in detail in any of the earlier publications, a relatively detailed description is included here. The filling procedure used in the present study differed from the earlier Fuze F7 studies in that the Eltor press was altered from dual to single pressing, and pressing weights were in kg adjusted to be almost identical to the lb loads used previously.

Five pressing tools were used:

Initiator holder, DWG ADE(X)331-2/1 & 2  
Spigot, Dwg TSE(X)648-2A  
Spigot base, Dwg TSE(X)648-3A  
Funnel, Dwg Z-64-772-3  
Pressing drift, Dwg unavailable

All these components were items found remaining from the Fuze F7 programme, and were used without modification. Extra spigots were prepared in the MRL mechanical workshops.

The initiator was held in the initiator holder, then the spigot and its base fitted at the bottom and the funnel at the top. The initiators were filled as a series each with the two high density (h.d.) increments, then the low density (l.d.) increments subsequently pressed in.

### 2.4.1 High Explosive Fillings

The h.d. increment was prepared by adding the appropriate HE (0.115 g), pressing at 320 kg dead load (d.l.), then a second 0.115 g was added and the unit repressed. The l.d. increment was formed by adding the RDX grade A in scoops (approx 0.12 g) and pressing after each addition at 33 kg d.l. This required nine incremental additions for complete filling. Following removal from the holder, the spigot was withdrawn leaving a cavity 3.175 mm in length, 1.016 mm diameter (see Fig. 1). Each initiator was then fitted with a self adhesive paper disc (Quik Stik) at the end of the stemming channel.

### 2.4.2 Pyrotechnic Fillings

The procedure was basically as described above for HE except that the high densities of the pyrotechnic fillings required the initial h.d. increment to be 0.2 - 0.25 g to adequately cover the spigot. Failure to do this resulted in a number of bent spigots during the exploratory stages. After addition and pressing of a second h.d. increment, eight to ten further increments were subsequently pressed in to form the l.d. stemming.

### 2.4.3 Filling of Plastic Initiators

Only HE fillings have been examined and the filling procedure was exactly as described above for aluminium initiators.

### 2.4.4 Fitting of Rubber Cap/Metal Cup

The rubber cap was placed over the initiation chamber in the initiator then the metal cup was pushed down to the body shoulder (see Fig. 1). The metal cup was cannellured in place using a hand operated Reeve Arbour Press No. 53P, utilizing compression of a rubber sleeve placed over the cup by a hollow drift.

## 2.5 Static Sensitivity Testing of Initiators and Components

### 2.5.1 Testing of Initiators

An initiator holder very similar to the Type 5 described in [15] was machined, differing only in the vent holes being horizontal rather than angled. Aluminium witness blocks were also as described in [15]. The witness block and initiator was fitted into the holder as shown in [15] except that neither a stemming covering cap nor a brass collar were used. The holder was then clamped to a base plate under the drop tower.

The initiator was impacted by a 1 kg weight, the height of drop being varied in a Bruceton staircase procedure [10]. After each "fire" the witness block was removed and depth of dent measured by a depth micrometer. Initiators remaining after a "no fire" were removed for disposal. Functioning levels for 50% initiation probability and standard deviation were calculated using standard Bruceton analysis [10]. In a few cases, notably the less sensitive pyrotechnic filled initiators, a 2 kg drop weight was used.

### 2.5.2 Testing of Plastic Initiating Plug

The initiator holder for dropweight testing was adapted using a machined aluminium section such that the plastic initiator plug (see Fig. 2) could be positioned at the top of the initiator metal cup. The initiator plug projected from the machined section. Plug designs were drop weight tested using the 2 kg weight dropped from 3 m.

## 3. RESULTS AND DISCUSSION

Three major areas of research were examined during the period covered by this report:

- (a) Investigation of potential high explosive and pyrotechnic fillings for the CI initiator.
- (b) Utilization of new silicone composition rubber caps which were expected to overcome the desensitization of the initiators upon climatic cycling, and attempts to define the processes leading to this desensitization.
- (c) Exploratory work on plastic components for the fuze.

All the studies described here, with the exception of those relating to (c) above, utilized anodized aluminium XF2 initiator moulds (bodies) still remaining from studies terminated some ten years previously.

It cannot be stressed too strongly that a major effort was required to commence the programme. Equipment from the Fuze F7 project had to be found and rejuvenated, test pieces rebuilt; a multitude of tasks were achieved in order that any productive results could be achieved. Some insight into these processes could be gained by consultation of the Experimental Section of this report.

### 3.1 Sensitivity of HE Filled Initiators

Initiator XF2 for Fuze F7 was filled first with two high density (h.d.) increments which incorporated the cavity, then nine low density (l.d.) increments (see Fig. 1 and Experimental Section). Initiation occurred in the h.d. increments, then burnt to detonation in the l.d. stemming [16,17]. The major part of the investigation described in this section was to define what range of initiator sensitivities could be achieved by use of readily available HE fillings. A secondary aim was to check whether substitution of the neoprene by a modern silicone rubber as cap material incurred a sensitivity penalty. In all investigations RDX grade A was used as the l.d. stemming, and the h.d. increments consisted of a range of RDX and PETN grades, as well as HMX and tetryl. Results are detailed in Table 2 and in all cases refer to anodized aluminium (XF2) initiators.

Substitution of neoprene by silicone rubber as the cap material does lead to lower impact sensitivity (RDX grade A entries, Table 2). However, allowing for standard deviations they are comparable, and all testing was subsequently carried out using silicone rubber caps. Note that the depth of dent on the witness blocks is significantly greater for the initiators fitted with neoprene caps.

The sensitivity order for the HE filled initiators is HMX < RDX grade A < tetryl < PETN (Table 2). This ordering correlates better with temperature of ignition (T of I) than figure of insensitiveness (F of I):

HMX	T of I [18]	260°C	F of I [9]	56
RDX		214°C		80
tetryl		173°C		86
PETN		174°C		51

This strongly suggests that the initiation processes are predominantly thermal in nature, i.e. adiabatic compression, with mechanical impact making a lesser contribution. Most of the experimental work and production F7 fuzes used RDX grade 1A (now known as grade B) (milled and boiled) as filling, where impact sensitivity ( $h_{50}$ ) was typically 2 lb/8.6 ft,  $\sigma = 0.1$  ft [14]. This is equivalent to  $1^{50}$  Kg/2.38 m; the greater sensitivity of the RDX grade A filled fuzes studied here is consistent with an earlier observation that Fuze F7 filled with UK RDX grade 1 (recrystallised) exhibited a sensitivity increase over RDX grade 1A [19]. PETN and PETN/tetryl (1:1) were also extensively investigated as fillings at various stages of the Fuze F7 programme [11,20,21].

Three modified compositions were investigated as the filling for the h.d. increment: RDX grade E, PETN K13 and RDX-polyethylene wax 95:5. The first two were studied because both are of small mean particle size (see Table 2), grade E RDX being used in propellant and PBX formulations while PETN K13 is used in exploding bridgewire (EBW) detonators. It was anticipated that the smaller particle size/higher surface area might aid ignition buildup and hence enhance sensitivity. However the results are contradictory (Table 2): grade E RDX is less sensitive than grade A RDX while PETN K13 is more sensitive than the larger particle size ICI PETN. A possible explanation is that the RDX grade E particle size is so small that it lowers permeability of hot gases into the column, inhibiting ignition buildup. In contrast, K13 PETN is sufficiently larger in particle size that this is not such a problem, and the very high surface area of this material enhances buildup. RDX-polyethylene wax 95:5 was investigated because it had been noted previously [19] that Fuze F7 filled with RDX grade 1A - polyethylene wax (ratio not specified) as h.d. increment was significantly more sensitive than Fuze F7 filled entirely with RDX grade 1A. This result was unexpected and unexplained [19]. In our studies a slight decrease in sensitivity was observed (Table 2).

The conclusion that can be drawn from the above results is that RDX grade A has adequate sensitivity for use as the initiator filling. The decision was therefore made to continue further development of the fuze using RDX grade A filled initiators. Should enhanced sensitivity and/or reproducibility be required, PETN could be substituted as the h.d. incremental filling.

A comment should be made on the depth of dent results (Table 2). Output from Initiator XF2 (in Fuze F7) was considered acceptable if the indentation into an aluminium alloy witness block was in the range 0.098-0.114 in (2.49-2.90 mm) [15], and a minimum dent of 0.10 in (2.54 mm) was subsequently incorporated into the performance specification [22]. Although half the fillings studied matched or exceeded this figure on average (Table 2), RDX grade A (silicone caps) was somewhat lower, indicating that transition to detonation had occurred nearer the end of the stemming. Detonation had obviously been achieved in all cases, as evidenced by inspection of the impacted initiator bodies. The deep, reproducible, dents produced by the PETN/RDX initiators (Table 1) suggests this to be the most reliable of the fillings studied.

The average dents observed for RDX grade E, RDX-polyethylene wax and particularly tetryl were quite small (Table 2). In addition, the witness blocks with very shallow dents usually had a coating of unreacted RDX (identified by IR spectroscopy) on the dent region, signifying explosion only.

At this stage it is not known whether the output from the fuze is required to be a detonation, or whether explosion only may be sufficient to adequately function the following explosive train elements. The inability of some of the compositions used in the h.d. increments to result consistently in detonation in the RDX stemming could rule them from further consideration.

### 3.2 Pyrotechnic Fillings

Although the Fuze F7 studies were principally concerned with HE fillings, a limited examination of pyrotechnic filled initiators was conducted. None of this work was published; a brief summary can be found in [2] and further information has become available through informal discussions particularly with Mr G.D. Thomson and Mr I. Glanville of FDL.

Pyrotechnic fillings were investigated in the current study for two main reasons. On a practical level, development of a low lethality practice round would be facilitated by use of a pyrotechnic rather than HE filled fuze. It should be stressed that, at this stage of the programme, the required output of the fuze had not been defined, and use of a pyrotechnic filled fuze was one development option being considered. The second reason for examining pyrotechnic fillings was their potential to probe further the initiation mechanism of the CI initiator. In particular, it might be possible to differentiate between purely thermal processes such as compression ignition and processes such as impact by the cap rubber.

The choice of materials to be studied was driven primarily by the latter project. A range of pyrotechnic compositions was selected on the basis that thermal (T of I) and mechanical (F of I) sensitivity encompassed a wide range of values. For the CI fuze project, the approach was taken that if promising materials were identified, related compositions could subsequently be examined. The compositions studied are listed in Table 1. Full details of T of I,  $T_{max}$  (from DSC traces), F of I and friction sensitivity (glancing blow test) for the loose compositions, as well as dropweight sensitivity and output/performance for the filled initiators, are listed in Table 3. Note that these initiators differed from the HE filled initiators in that both the h.d. and l.d. increments were the same composition.

The pyrotechnic fillings are listed in Table 3 in approximately decreasing order of thermal sensitivity as measured by T of I and  $T_{max}$ . Unlike the limited HE series studied (see previous section) there is no systematic decrease in 50% functioning energies as T of I/ $T_{max}$  decreases. T of I and  $T_{max}$  are not directly comparable due to the different experimental conditions under which these parameters are determined [23]. Either parameter gives a reasonable measure of ignitability for explosives. In general, ignition temperature data measured on pyrotechnics is very dependent

upon experimental conditions [24], and does not agree with observations either on ease of ignition [25a] or energies required for ignition [25b]. The poor correlation observed for the CI initiators should perhaps have been expected. Mechanical sensitivity appears to be exhibiting some influence; RD1362(HD), which is similar to a primary explosive in sensitivity, is very sensitive in the CI initiator while SFG 40, which is the least mechanically sensitive of the series, has very low sensitivity in the initiator. However SR399 is also quite mechanically sensitive but the CI initiators are not particularly sensitive. Further discussion on the mechanism of pyrotechnic initiation under these conditions must await further experimental results.

The results show clearly that pyrotechnic filled initiators with comparable sensitivity to HE filled initiators could be developed. Two whistle compositions, SR 136 and MRL(X)409, were briefly examined during the course of the work and results are listed at the end of Table 3. A number of composition types have been identified which are unsuitable, including SR 252 which reportedly gave promising results during the Fuze F7 studies [26]. The nature of the output from initiators which functioned varied from burning with poor propagation through to explosion (Table 3). Burning of pyrotechnics is a slow process relative to HE burn-to-detonation in the l.d. stemming. One problem resulting from slow burning (function) of the fuze would be that considerable penetration into target material will have occurred before subsequent elements in the explosive train functioned. This could result in obscuration of visible signals to the forward observers in the field.

### 3.3 Desensitization of Initiators Upon Climatic Cycling

Desensitization of assembled Fuze F7 and the corresponding filled initiators upon climatic cycling was a problem right throughout the Fuze F7 project. A thorough presentation and investigation of the evidence can be found in Ref. [2]. For example, there was a marked decrease in sensitivity to drop weight testing after 6 months under ISAT(A) storage [27] and after only 2 weeks under ISAT(B) storage [28,29]. It should be stressed that there is little evidence that long term ambient storage resulted in loss of activity [2].

The desensitization was traced to two mechanisms; a short term reversible process caused by depletion of oxygen from the initiator compression chamber, and a longer term irreversible process of unknown origin [2]. The depletion of oxygen was almost certainly due to reaction of residual unsaturation in the neoprene caps with oxygen from the cavity. One possible cause of the longer term desensitization was migration of plasticiser or another component of the neoprene into the cavity in the explosive, coating the surface and inhibiting ignition or propagation [2]. A second possible cause was surface change of the RDX. RDX grade B (then grade 1A) was used in Fuze F7, and it was noted that UK RDX grade A filled initiators deteriorated significantly more slowly [27]. Since RDX grade A was being used throughout this present project, it was possible that the desensitization would not be a significant problem.

Two approaches were used to study the desensitization phenomenon. The first approach, following discussions with Mr T.E. Symes of OCD, MRL, was

to use a modern silicone rubber as cap material. Silicone rubber has the dual advantage over neoprene of no residual unsaturation, hence no reaction with oxygen, and no plasticiser for migration. The formulation suggested was MRL 1457 (see Experimental), chosen because of high strength and softness. In both these properties it was superior to the S6508 investigated previously in the Fuze F7 project [14]. CI initiators were filled with RDX grade A and fitted with silicone caps, and subjected to a thermal cycle of 20°C then 65°C at 6 h periods - neither ISAT(A) nor ISAT(B) was available at the time due to equipment malfunction. The initiators were to be removed at intervals and assessed by radiography, breakdown and dropweight testing.

The second approach was designed to test whether plasticiser migration resulted in surface contamination. In this test pellets of RDX grade A were positioned in a petri dish under a metal cup/fitted rubber cap. The samples consisted of silicone, new neoprene and old neoprene (remaining from factory production) caps and were thermally cycled as described above. Surface contamination would be assessed by Fourier transform infrared spectroscopy (FTIR).

Initiators were removed from 20°C/65°C thermal cycling after 7.5 months. Half were dropweight tested as received. The cups and caps were removed from the remainder, then they were dropweight tested following equilibration with atmosphere and refitting new caps and cups. Results are listed below:

<u>Initiator</u>	<u>Result for 50% initiation probability</u>
7.5 months thermal cycling, used as received	1 kg/4.08 m
7.5 months thermal cycling, refitted with new caps and cups following equilibration	1 kg/2.85 m
Standard RDX filled initiator	1 kg/1.66 m

The data clearly indicates a decline in sensitivity. Further, two mechanisms appear to be operating, as discussed above from the Fuze F7 studies. Depth of dents in witness blocks had also deteriorated, the average was only 1.21 mm compared with 1.88 m (Table 1) for standard RDX initiators. All fuzes detonated following initiation.

Considering that the thermal cycle used here is more severe than the ISAT(A) used previously for Fuze F7, some progress has been made on alleviating the problem of loss of sensitivity. Confirmation by direct comparison between initiators fitted with neoprene and silicone caps will be made using ISAT(B) in January 1986, when this facility is restarted. One qualitative observation made during the testing described above was that the aluminium cups removed from the thermally cycled fuzes were significantly more brittle than new cups. This was not noted in the Fuze F7 studies and is a possible cause of loss of sensitivity; the aluminium cup could fracture

before pressure in the initiation chamber had reached or been maintained at the required level for sufficient time, lowering the probability of ignition. This aspect will also be addressed in 1986.

The second part of this project was commenced at an earlier stage, with the first RDX pellets being removed after 3 months' thermal cycling. Analysis of the pellet surface by FTIR revealed that the surface of the pellet exposed below a neoprene cap had deteriorated relative to a control pellet, whereas the pellet exposed below a silicone cap had no detectable surface change. However there was insufficient absorption to detect specific contaminants such as the carbonyl frequency of the plasticiser in neoprene. Further samples were taken after 7.5 months but due to unavailability of FTIR they have not been assayed. This will be done early in 1986, and on the basis of these results further samples may be examined after additional periods have elapsed.

The combination of dropweight sensitivity and surface analysis by FTIR suggests strongly that some improvement in performance has been achieved by use of the silicone caps. However the problem of desensitization has not been entirely eliminated, and this will continue as a major area of study in 1986.

#### 3.4 Assessment of Plastic Components

The prototype "plastic" fuze is shown in Fig. 2. It was anticipated that all components with the exception of the rubber cap, aluminium cup and shear wire (parts 7 to 9 on Fig. 2) would be of injection moulded plastic. However financial and time constraints limited moulding to the initiator mould and body (parts 6 and 2, Fig. 2) with other components being machined from bar stock. The first live firings of the fuze fitted to an 81 mm mortar round occurred in November 1985, using XF2 aluminium initiator moulds and a machined fuze body. The results from these trials will be reported separately.

Two potential problems were addressed in the course of the work reported here. The first was the design of the initiating plug. The original design as conceived is shown as part 1 in Fig. 2. Impact on target would lead to breakage of the shear wire, crushing of the cup and cap and subsequent ignition of the explosive. The filled initiator (grade A RDX) with the initiator plug sitting atop and held in a modified holder (see Experimental Section) was impacted with a 2 kg mass from 3 m - these conditions were chosen so that they were well in excess of impact energies necessary to initiate grade A RDX filled initiators. In the test only 1/5 initiators functioned. Presumably failure results from insufficient clearance to crush the initiator cavity in the required short time frame. The problem was solved simply by machining off the curved section of the plug flush with the initiator cup, as shown by the dotted lines in Fig. 2. Repetition of the 2 kg/3 m impact test resulted in 5/5 detonations. The modified initiator plug was considered satisfactory for field testing.

The other area investigated was whether the plastic initiator (part 6, Fig. 2) made from moulded glass-fibre reinforced noryl functioned comparably with the aluminium initiator, i.e. that there was sufficient confinement for detonation, and sensitivity was unchanged. The first batch were delivered by EFM early in December 1985. However sectioning of the initiators revealed gross defects due to shrinkage in the middle section of the stemming channel. A second batch prepared in a modified manner partially solved this problem and dropweight testing was commenced on these specimens.

A total of eight initiators were filled with RDX grade A and dropweight tested using 1 kg at heights up to 4.5 m. All failed and subsequent removal of the crushed cup and cap revealed that fracture had occurred vertically in the neck region of the initiator. The probable result of this would be loss of pressure before a temperature sufficient to ignite the explosive had been reached. Dropweight testing of initiators filled with PETN (h.d.) and RDX (l.d.) increments was also investigated. It was anticipated that the higher sensitivity of PETN filled initiators (Table 2) might be sufficient to overcome the initiator fracture. However again all initiators failed although partial ignition was indicated in one case. Failure to propagate must have been caused by fracture before pressure had been maintained for sufficient time. Dropweight testing of both empty and inert-filled (dextrin) initiators fitted with cups and caps revealed that fracture around the neck of the initiator occurred readily even at 1 kg/2 m.

40% Glass-filled noryl is unsuitable for use in the initiators, probably due to being too brittle, but should still be a suitable material for the fuze body (part 2, Fig. 2). Deliveries of fuze bodies are expected to commence in January 1986. Initiators moulded from other plastics will be investigated at the same time. It may be necessary to revert to machined aluminium initiators.

#### 4. CONCLUSION

The twelve months to the end of 1985 have seen substantial progress on the CI fuze project, culminating in a successful field trial. The results of this field trial will be reported separately. Some parts of the project have been completed, some problems have been partially solved, while several key points will be addressed starting January 1986.

Both HE and pyrotechnic fillings have been studied and a range of suitable materials encompassing a range of sensitivity and performance identified. The required output from the fuze has not been clearly defined as yet, and development work has proceeded only on HE filled initiators. Most developmental work has been on RDX grade A filled initiators, and this was the type used in the field trials. More attention will be paid in 1986 to PETN as an alternative filling due to its higher sensitivity and more reproducible performance.

The problem of loss of sensitivity of the initiator induced by thermal cycling has been partially solved, and a major effort will be concentrated in this area in 1986. Plastic components became available towards the end of 1985, and most performed satisfactorily in the field trials using aluminium XF2 initiators. The design of the nose plug will need further improvement, and a material appropriate for the shear wire will need to be identified. All studies during the year were conducted on aluminium XF2 initiators with the exception of some exploratory work on moulded glass-filled noryl initiators which became available in December. These initiators failed to function due to fracture around the neck region. A major part of the programme in 1986 will be directed to identification of a suitable plastic material for the initiator. This will have to be achieved quickly. If no such material can be found, machining of aluminium initiators identical to the plastic initiator in Fig. 2 will have to be organised in time for the field trials scheduled for the first part of 1986.

Finally, an alternative filling method will be developed. The current filling method requires nine increments in the l.d. stemming. This is relatively expensive and not ideally suited to a low cost item, although it was used for Fuze F7 production.

#### 5. ACKNOWLEDGEMENTS

Clearly a project of this size involved more people than the four who appear as authors. Technical assistance was provided by Mr R. Porteous, Mr B Jones, Mr E. Wanat, Mr S. Murdoch and Mr M. Wilson. Several people at FDL provided support and information, particularly Mr D. Botterill, Mr N. Porteous, Mr G.D. Thomson and Mr I. Glanville, while at EFM Mr A.J. Bridger and Mr M. Ames and his group were the chief contributors. A number of people at MRL gave freely of their guidance and knowledge, and foremost were Mr J.R. Bentley and Mr M.G. Wolfson of PCD, while Mr J. Roseblade and Mr T.E. Symes of OCD provided the expertise on plastics and rubbers respectively.

## 6. REFERENCES

1. Smith, M.M. and Dace, R.J. (1984). "Fuzing Options for Current 81 mm HE and Smoke WP Mortar Ammunition", Materiel Branch/Munitions Division Report, Dept. of Defence, Canberra.
2. Spear, R.J. (1985). "The Australian Compression Ignition (CI) Fuze: A History of Research and Development and Suggestions for use in Fuzes for Practice Ammunition", MRL-R-955, Materials Research Labs., Maribyrnong.
3. Spear, R.J. and Nanut, V. (1985). Unpublished results of work conducted at Materials Research Labs., Maribyrnong.
4. Cackett, J.C. (1971). "The Properties of SR Pyrotechnic Compositions", RARDE Report 1/71, Royal Armament Research and Development Establishment, Fort Halstead, Kent, UK.
5. Davies, N. (1983). "The Manufacture and Properties of SR371A and SR371C", RARDE Pyrotechnic Information Sheet 21, Memo 57/83, Royal Armament Research and Development Establishment, Fort Halstead, Kent, UK.
6. UK Explosives Safety Certificate No. 1029.
7. UK Explosives Safety Certificate No. 1013.
8. UK Explosives Safety Certificate No. 1031.
9. Mortlock, H.N. and Wilby, J. (1966). Explosivestoffe 16, 49.
10. Culling, H.P. (1953). "Statistical Methods Appropriate for Evaluation of Fuze Explosive-Train Safety and Reliability", NAVORD Report 2101, US Naval Ordnance Lab., Whiteoak, Maryland.
11. Osborne, W.P. (1958). "Development of Fuze, DSL type 4 Mark 3", DSL-R-238, Defence Standards Labs., Maribyrnong.
12. Dunn, P. and Liggins, T. (1967). "Rubber Plugs for Detonantless Fuzes", DSL-TN-97, Defence Standards Labs., Maribyrnong.
13. Symes, T.E. Unpublished results of work conducted at Materials Research Labs., Maribyrnong.
14. Connick, W., Wiese, E.F. and Jackson, J.G. (1965). "A Sensitivity Test for Static Functioning of Compression Ignition Fuze Initiators", DSL-TM-11, Defence Standards Labs., Maribyrnong.
15. Wiese, E.F., Jackson, J.G. and Wolfson, M.G. (1966). "An Investigation of the Donor Power of Compression Ignition Fuze Initiators. Part II", DSL-TM-15, Defence Standards Labs., Maribyrnong.

16. Connick, W. and Wolfson, M.G. (1965). "An Investigation of the Donor Power of Compression Ignition Fuze Initiators. Part I", DSL-TM-13, Defence Standards Labs., Maribyrnong.
17. Howlett, S.L. (1963). "A Study of the Initiation and Growth to Detonation in an Explosive Stemming", DSL-R-265, Defence Standards Labs., Maribyrnong.
18. UK Explosives Safety Certificates Nos. 921A, 369, 1124A and 1107 respectively.
19. Humphris, P.J. and Dillon, T. (1965). "Polyethylene Wax - A New Desensitizer for RDX/TNT. Part 1. Coating RDX Grade 1A with 1% Polyethylene Wax AC629", Explosives and Ammunition Group Note No. 11/65, Materials Research Labs., Maribyrnong.
20. Anon (1958). "Fuze Development - Detonantless System. The Development of an Initiation System Filled High Explosive", DSL-R-236, Defence Standards Labs., Maribyrnong, and earlier report cited therein.
21. Wiese, E.F. and Thomson, G.D. (1966). "Report on Trial ED 66/2. A Trial of Compression Ignition Fuzes", Explosives and Ammunition Note No. 11/66, Defence Standards Labs., Maribyrnong.
22. Pierce, J.R. (1976). "Investigation No. 1390-3M-QAD3. Fuze PD F7 Malfunction in Service. 3AQU Final Report".
23. Whelan, D.J., Spear, R.J. and Read, R.W. (1984). Thermochim. Acta 80, 149.
24. Conkling, J.A. (1985). "Chemistry of Pyrotechnics: Basic Principles and Theory", Marcel Dekker Inc., NY. Ch. 5, p.97-124.
25. McLain, J.H. (1980). "Pyrotechnics from the Viewpoint of Solid State Chemistry", Franklin Institute Press, Phil., PA. a p.185, b p.177
26. Thomson, G.D. (1984). Personal communication.
27. Wiese, E.F. and Jackson, J.G. (1966). "An Investigation into the Effect of Climatic Storage on the Drop Weight Sensitivity of Compression Ignition Fuze Initiators", Explosives and Ammunition Group Note No. 3/66, Defence Standards Labs., Maribyrnong
28. Humphris, P.J., Wiese, E.F. and Thomson, G.D. (1966). "Report on Trial ED 66/3. A Trial of Compression Ignition Fuzes", Explosives and Ammunition Note No. 12/66, Defence Standards Labs., Maribyrnong.
29. Humphris, P.J. and Wiese, E.F. (1967). "A Drop Weight Sensitivity Test for Compression Ignition Fuze Initiators. The Development of a Laboratory Test to Facilitate Prediction of Initiator Performance in the Field - Part I", Explosive and Ammunition Composite Note No. 1/67, Defence Standards Labs., Maribyrnong.

TABLE 1

PYROTECHNIC COMPOSITIONS ASSESSED AS FILLINGS IN CI INITIATORS

<u>Composition</u>	<u>Components and Percentages</u>
SR112	Potassium nitrate (60%), tetranitrocarbazole (40%)
RD1362(HD)	Boron (5%), lead oxide (95%)
SR399	Magnesium grade 4 (12%), barium peroxide (86%), acroid resin (2%)
G40	Potassium nitrate (75%), charcoal (15%), sulphur (10%) [Commercial gunpowder, granular size 40]
SFG40	Potassium nitrate (70%), charcoal (30%) [Commercial sulphurless gunpowder, granular size 40]
SR371A	Magnesium grade 3 (42%), potassium nitrate (50%), acroid resin (8%)
SR371C	Magnesium, cut, grade 3 (32%), magnesium, cut, grade 5 (10%) potassium nitrate (50%), acroid resin (8%)
SR252	Silicon (40%), potassium nitrate (40%), sulphurless mealed powder (20%)
SR189	Barium nitrate (61%), tetranitrocarbazole (39%)
SR46(MOD)	Zirconium/nickel alloy powder (50%), molybdenum trioxide (50%)
SR136	Potassium perchlorate (72%), potassium benzoate (28%)
MRL(X) 409	Potassium perchlorate (68.25%), potassium benzoate (29.25%), silicone high vacuum grease (2.50%)

TABLE 2

IMPACT TESTING DATA FOR ALUMINIUM CI INITIATORS FILLED WITH VARIOUS HE COMPOSITIONS IN  
THE HIGH DENSITY INCREMENTS AND RDX GRADE A STEMMING <sup>a</sup>

Explosive Filling in High Density Increment	Impact Sensitivity (1 kg weight)			Witness Block depth of dent <sup>b</sup>	
	h 50% (m)	std.dev.	E 50% (J)	Mean (mm)	Range (mm)
Composition	Particle Size Mean (μm)				
RDX Grade A	275	0.12	17.66	1.88	0.94 - 2.67
RDX Grade A (neoprene caps)	275	0.37	15.80	2.57	1.91 - 2.92
RDX Grade E	26	0.93	24.33	1.24	0.61 - 2.41 <sup>c</sup>
RDX/polyethylene wax 95:5	420	0.62	19.36	0.46	0.08 - 1.50 <sup>c</sup>
HMX	485	0.26	20.41	2.92	2.64 - 3.25
PETN ex ICI	310	0.45	11.78	3.23	3.05 - 3.50
PETN K13	52	0.19	7.78	2.39	1.27 - 3.12
Tetryl	160	0.19	12.67	0.18	0.0 - 0.56 <sup>c</sup>

<sup>a</sup> Rubber caps used were silicone unless indicated .

<sup>b</sup> Results only for initiators which functioned following impact

<sup>c</sup> Witness blocks with small dents still had unreacted RDX adhering

TABLE 3

THERMAL AND MECHANICAL SENSITIVITY OF PYROTECHNIC COMPOSITIONS USED AS FILLINGS IN ALUMINIUM CI INITIATORS AND IMPACT TESTING DATA FOR THE FILLED INITIATORS

Composition <sup>a</sup>	Thermal Parameters (°C)		Mechanical Sensitivity		Functioning of Filled Initiators		Performance
	T of I	T <sub>max</sub> (DSC)	F of I <sup>b</sup>	Glancing Blow (J) <sup>c</sup>	Impact Sensitivity <sup>d</sup>	50% function [std.dev.]	
SR112	285	366	120	> 11.0	1 kg/1.20 m	[0.25 m]	Burnt with hissing or explosion
G40	300	306	110	> 11.0	1 kg/3.89 m	[0.65 m]	Explosion with or without delay
SFG40	385	411	200	> 11.0	2 kg/5 m	1/6	Explosion
SR399	> 400	382	65	3.3	2 kg/3.03 m	[0.65 m]	Burnt with hissing sound
RD1362(HD)	> 400	453	30	0.9	1 kg/0.3 m	<sup>e</sup>	Burnt starting with cracking sound
SR46(MOD)	> 400	563	80	> 11.0	1 kg/0.96 m	[0.5 m]	Burnt with hissing
SR252	> 400	556	80	3.3	2 kg/5 m	0/5	Burnt with hissing
SR189	> 400	583	140	> 11.0	1 kg/1.92 m	[1.1 m]	Burnt but propagated poorly
SR371A	> 400	596	110	> 11.0	2 kg/5 m	0/3	
SR371C	> 400	596	110	> 11.0	2 kg/5 m	0/3	
SR136	403 <sup>g</sup>		70 <sup>g</sup>		1 kg/1 m	1/1 <sup>f</sup>	Explosion
MRL(X)409	> 400		150	> 11.0	1 kg/1 m	1/1 <sup>f</sup>	Explosion

<sup>a</sup> Full details of composition can be found in Table 1

<sup>b</sup> Relative to RDX=80. Upper limit for the test is 200

<sup>c</sup> Lowest level at which ignitions occurred

<sup>d</sup> Determined by standard Brucceton [10] procedure. The maximum input energy was 2 kg/5 m and functioning at this level only is listed for the less sensitive compositions

<sup>e</sup> Standard deviation not estimated

<sup>f</sup> 1 kg/2 m and 1 kg/3 m both 1/1

<sup>g</sup> Data from Ref. [8]

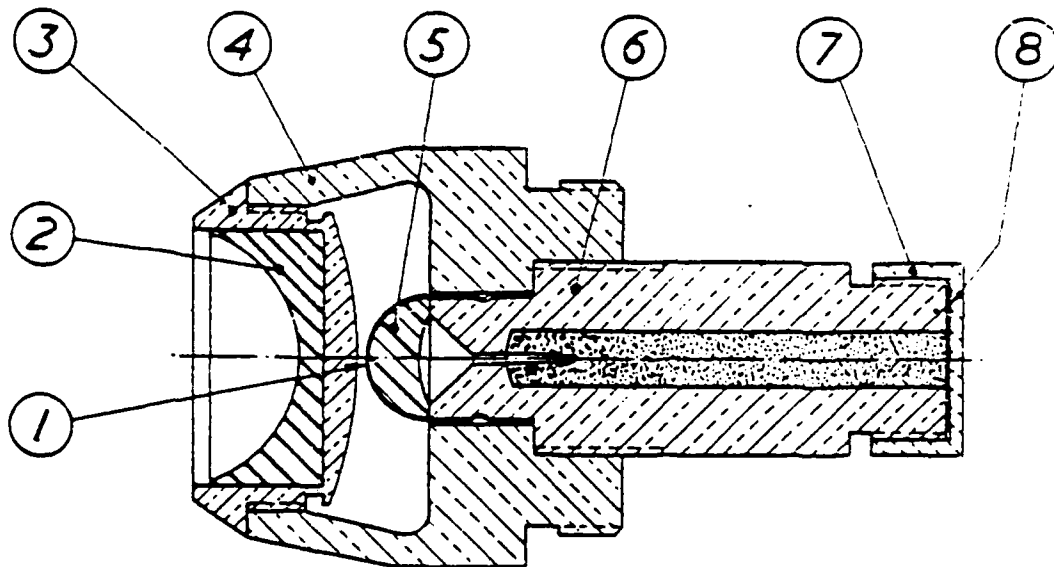

FIGURE 1

An illustration of the Wandella F7 Fuze for 81 mm Mortar ammunition. The Fuze body and magazine are not shown. The numbers on the diagram refer to the following components:

1. Metal cup
2. Insert
3. Nose shear diaphragm
4. Nose body
5. Rubber cap
6. Initiator body (mould)
7. Stemming cover
8. Paper disc

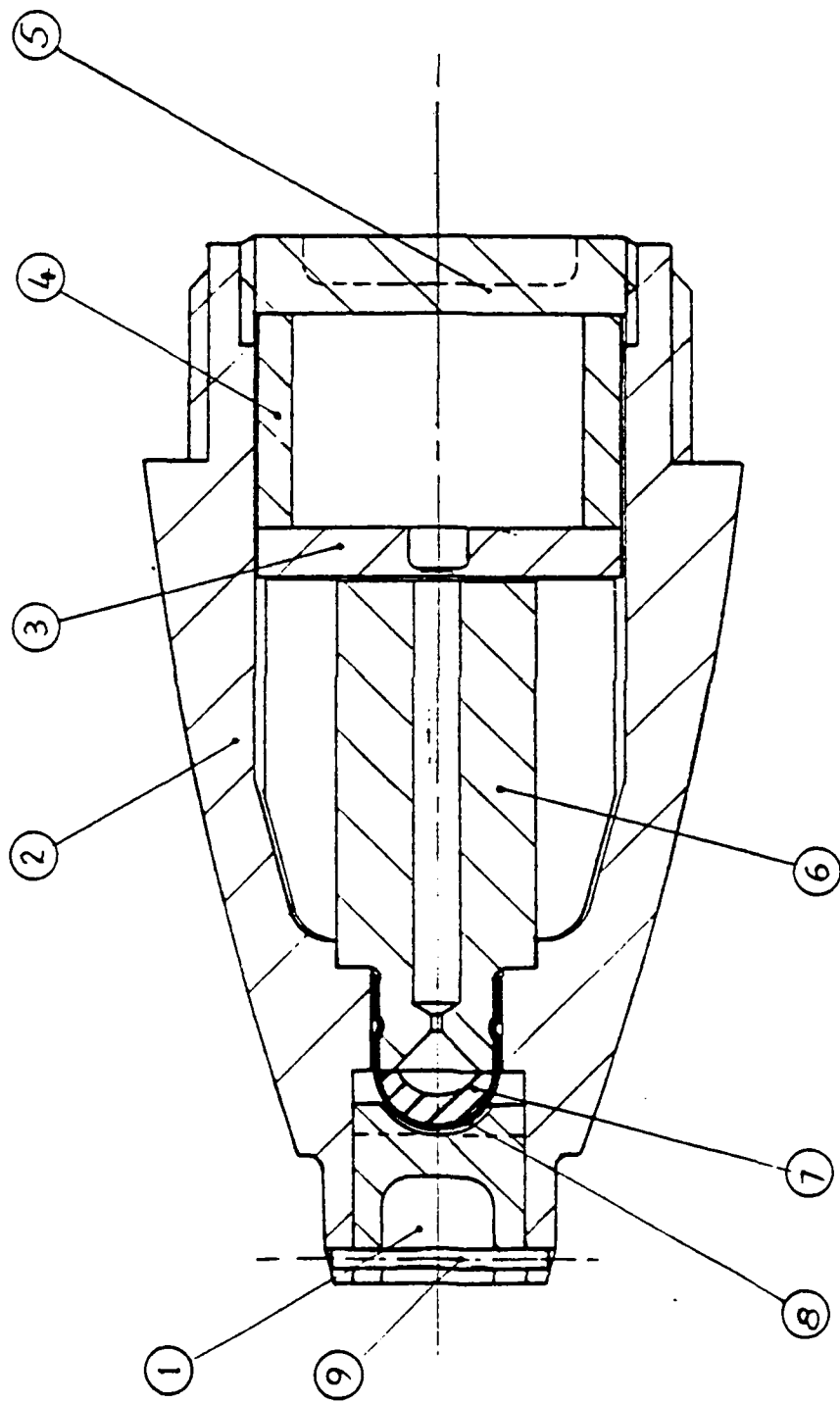

FIGURE 2 Assembled components for an unfilled 81 mm Practice Fuze Mk 1. Component listing:  
 1. Initiating plug; the modified initiator plug used for development models (see text) was machined along the dotted line as shown. 2. Body 3. Stemming Disc  
 4. Booster sleeve 5. Plug 6. Initiator mould 7. Rubber cap  
 8. Aluminium cup 9. Shear wire

END

12-86

DTIC