

AD-A173 854

HOT FUEL NOZZLE FOULING TEST FACILITY(U) SOUTHWEST
RESEARCH INST SAN ANTONIO TX BELVOIR FUELS AND
LUBRICANTS RESEARCH FACILITY J C TYLER ET AL. DEC 85
BFLRF-206 DAAK70-82-C-0001 F/G 21/4

1/1

UNCLASSIFIED

NL



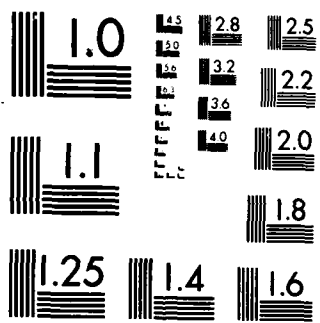

MICROCOPY RESOLUTION TEST CHART
NATIONAL BUREAU OF STANDARDS-1963-A

AD-A173 854

12

HOT FUEL NOZZLE FOULING TEST FACILITY

INTERIM REPORT
BFLRF No. 206

By

J.C. Tyler

B.R. Wright

Belvoir Fuels and Lubricants Research Facility (SwRI)
Southwest Research Institute
San Antonio, Texas

Prepared for

David W. Taylor Naval Ship Research and Development Center
Annapolis Laboratory
Annapolis, MD

Under Contract to

U.S. Army Belvoir Research, Development
and Engineering Center
Materials, Fuels and Lubricants Laboratory
Fort Belvoir, Virginia

Contract No. DAAK70-85-C-0007

Approved for public release; distribution unlimited

December 1985

DTIC FILE COPY

DTIC
ELECTE
NOV 05 1986
S D
E

86 11 11 11

Disclaimers

The findings in this report are not to be construed as an official Department of the Navy or Army position unless so designated by other authorized documents.

Trade names cited in this report do not constitute an official endorsement or approval of the use of such commercial hardware or software.

DTIC Availability Notice

Qualified requestors may obtain copies of this report from the Defense Technical Information Center, Cameron Station, Alexandria, Virginia 22314.

Disposition Instructions

Destroy this report when no longer needed. Do not return it to the originator.

Unclassified

SECURITY CLASSIFICATION OF THIS PAGE

REPORT DOCUMENTATION PAGE

1a. REPORT SECURITY CLASSIFICATION Unclassified			1b. RESTRICTIVE MARKING None		
2a. SECURITY CLASSIFICATION AUTHORITY N/A			3. DISTRIBUTION/AVAILABILITY OF REPORT		
2b. DECLASSIFICATION/DOWNGRADING SCHEDULE					
4. PERFORMING ORGANIZATION REPORT NUMBER(S) Interim Report BFLRF No. 206			5. MONITORING ORGANIZATION REPORT NUMBER(S)		
6a. NAME OF PERFORMING ORGANIZATION Belvoir Fuels and Lubricants Research Facility (SwRI)		6b. OFFICE SYMBOL (If applicable)	7a. NAME OF MONITORING ORGANIZATION U.S. Army Belvoir Research, Development and Engineering Center		
6c. ADDRESS (City, State, and ZIP Code) Southwest Research Institute, P.O. Drawer 28510 (6220 Culebra Rd), San Antonio, TX 78284			7b. ADDRESS (City, State, and ZIP Code) Fort Belvoir, VA 22060-5606		
8a. NAME OF FUNDING/SPONSORING ORGANIZATION David Taylor Naval Ship Research & Dev. Center		8b. OFFICE SYMBOL (If applicable) MFG, Code 2759	9. PROCUREMENT INSTRUMENT IDENTIFICATION NUMBER DAAK70-82-C-0001; WD 25 DAAK70-85-C-0007; WD18,19		
8c. ADDRESS (City, State, and ZIP Code) Annapolis Laboratory Annapolis, MD 21402			10. SOURCE OF FUNDING NUMBERS		
			PROGRAM ELEMENT NO.	PROJECT NO.	TASK NO.
			WORK UNIT ACCESSION NO.		
11. TITLE (Include Security Classification) Hot-Fuel Nozzle Fouling Test Facility (U)					
12. PERSONAL AUTHOR(S) Tyler, J.C.; Wright, B.R.					
13a. TYPE OF REPORT Interim		13b. TIME COVERED FROM Dec 83 to Dec 85		14. DATE OF REPORT (Year, Month, Day) 1985 December	15. PAGE COUNT 19
16. SUPPLEMENTARY NOTATION					
17. COSATI CODES			18. SUBJECT TERMS (Continue on reverse if necessary and identify by block number)		
FIELD	GROUP	SUB-GROUP	turbine nozzle fouling, thermal stability, flow-divider hysteresis.		
19. ABSTRACT (Continue on reverse if necessary and identify by block number) Based on prior testing of turbine engine flow divider valves and/or fuel atomizing nozzles, it has been concluded that additional nozzle fouling data on both specification and near-specification distillate fuels are needed. The nozzles and fuels of interest would be employed for both Navy shipboard and Navy aircraft applications. Therefore, a hot-fuel nozzle fouling test facility was designed and constructed and is discussed in this report. Also, limited shakedown testing showing the potential of the facility is presented. A test program utilizing four engine nozzle designs and three middle distillate fuels having different JFTOT breakpoint temperatures is recommended.					
20. DISTRIBUTION/AVAILABILITY OF ABSTRACT <input checked="" type="checkbox"/> UNCLASSIFIED/UNLIMITED <input type="checkbox"/> SAME AS RPT. <input type="checkbox"/> DTIC USERS			21. ABSTRACT SECURITY CLASSIFICATION Unclassified		
22a. NAME OF RESPONSIBLE INDIVIDUAL F.W. Schaeckel			22b. TELEPHONE (Include Area Code) (703) 664-3576		22c. OFFICE SYMBOL STRBE-VF

DD FORM 1473, 84 MAR

83 APR edition may be used until exhausted.
All other editions are obsolete.

SECURITY CLASSIFICATION OF THIS PAGE
Unclassified

FOREWORD

This work was conducted at the Belvoir Fuels and Lubricants Research Facility (SwRI), Southwest Research Institute, under DOD Contract Nos. DAAK70-82-C-0001 and DAAK70-85-C-0007. The project was administered by the Fuels and Lubricants Division, Materials, Fuels, and Lubricants Laboratory, U.S. Army Belvoir Research, Development and Engineering Center, Fort Belvoir, Virginia 22060-5606, with Mr. F.W. Schaekel, STRBE-VF, serving as Contracting Officer's Representative. This program was funded by the U.S. Navy David Taylor Naval Ship Research and Development Center with Mr. R. Strucko, Mobility Fuels Group, Code 2759, serving as Technical Monitor. This report covers the period of performance from December 1983 to December 1985.

Accession For	
NTIS GRA&I	<input checked="" type="checkbox"/>
DTIC TAB	<input type="checkbox"/>
Unannounced	<input type="checkbox"/>
Justification	
By _____	
Distribution/	
Availability Codes	
Dist	Avail and/or Special
A-1	



TABLE OF CONTENTS

<u>Section</u>		<u>Page</u>
I.	INTRODUCTION AND BACKGROUND	5
II.	TEST FACILITY	7
	A. General	7
	B. Fuel Flow Section	7
	C. Fuel Heating Section	9
	D. Air Heating Section	11
	E. Test Tunnel Section	11
	F. Test Facility Capabilities	13
III.	TEST RESULTS	15
IV.	CONCLUSIONS AND RECOMMENDATIONS	16
V.	REFERENCES	19

LIST OF ILLUSTRATIONS

<u>Figure</u>		<u>Page</u>
1	F404 and T700 Fuel Nozzles	6
2	Hot-Fuel Nozzle Test Facility Schematic	8
3	Oil Heater System for Supplying Heat Medium to Oil/Fuel Heat Exchanger	10
4	Air Heating Section of Test Facility With Attached Test Tunnel	12
5	Test Tunnel Section of Test Facility With Attaching Trans- formation Duct	12
6	Simplex Nozzle Flow Characteristics Using No. 2 Diesel Fuel at 210°C (410°F)	16
7	Hot-Fuel Nozzle Fouling Facility Test Matrix	18

I. INTRODUCTION AND BACKGROUND

During the past several years, hot-fuel nozzle (atomizer) fouling tests have been conducted by the General Electric Company in Evendale, OH (1-3)* in support of both U.S. Navy and U.S. Air Force programs. The results of these tests have shown that the "fouling life" of atomizers and flow divider valves can be somewhat correlated to the "breakpoint" temperature of the utilized fuel. The "fouling life" has been arbitrarily defined in terms of an increase in divider valve hysteresis and/or a reduction in fuel flow through the atomizer at some constant rated pressure drop through the same atomizer. In both cases, it is likely that deposition has occurred in a region of small clearances in the atomizer. This is likely to occur in both the orifice and the numerous small entrances to the spin chamber, as well as on other surfaces wetted by the hot fuel.

Also during fiscal year 1984, a number of distillate fuels were characterized at Southwest Research Institute (SwRI) (4) as to their specification physicochemical properties and thermal stability breakpoint temperature as measured by the Jet Fuel Thermal Oxidation Tester (JFTOT). Regression analysis was performed using breakpoint temperature as the dependent variable and other fuel properties as independent variables. The analysis identified several significant fuel properties such as carbon residue, cetane number, sulfur content, etc., which appear to influence thermal stability breakpoint. Therefore, based on these findings and the hot-fuel nozzle fouling life correlation observed by General Electric, it was concluded that a hot-fuel nozzle fouling test facility was needed. This facility could be utilized for testing turbine engine flow divider valves and/or nozzles employed on shipboard, ground and aircraft applications.

Fuel flow rates to gas turbine engines may vary over a range of 10 to 1 for conditions from ignition to full power. Ignition requires reasonably good atomization of the fuel, which corresponds to a pressure drop across a pressure-swirl atomizer of at least 25 psi (172.4×10^3 Pa). Since the flow rate increases as the square of the pressure, to increase the flow rate by a factor of 10 for full power would require a fuel pressure increase to approximately 2500 psi ($17,240 \times 10^3$ Pa). Therefore, to maintain reasonable fuel pump pressures (much less than 2500 psi), two different sizes of pressure-swirl atomizers are

* Underscored numbers in parentheses refer to the list of references at the end of this report.

often employed, i.e., a small-capacity nozzle for ignition and a higher capacity nozzle for higher power conditions. A flow divider valve is necessary to prevent flow to the larger capacity nozzle until the fuel pressure exceeds that used for ignition. It is common practice to combine the small-capacity and high-capacity atomizers in one dual-orifice nozzle with the primary orifice in the center of an annular secondary injector. The flow divider valve may be incorporated into the atomizer, resulting in a single-entry, dual orifice nozzle, or the flow divider valve may be external to the atomizer, resulting in a dual-entry, dual-orifice nozzle. The flow divider valve, normally a spring-loaded device, simply provides full fuel pump pressure to primary nozzle only at ignition conditions and then begins to open at higher pressures to provide flow to the secondary. These nozzles are designed to exhibit increasing fuel flow through the secondary injector with increasing inlet fuel pressure. Figure 1 illustrates typical differences that are normally found in the two nozzle variations.

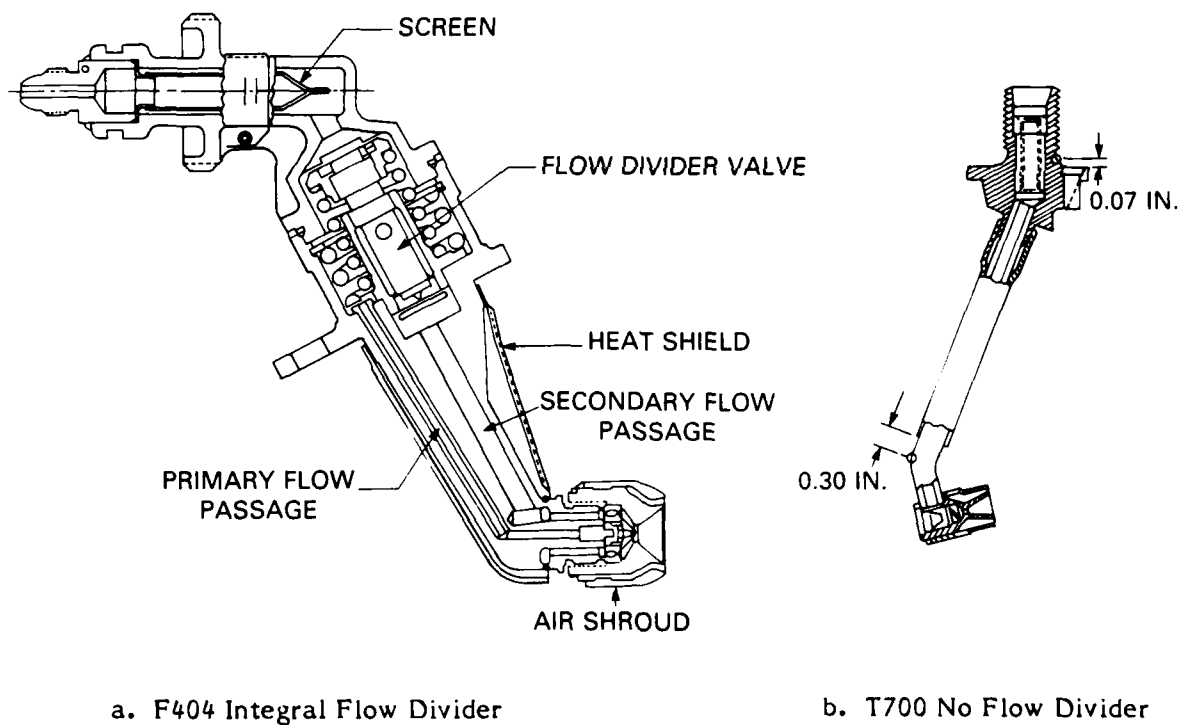

FIGURE 1. F404 AND T700 FUEL NOZZLES

The test facility designed and discussed herein would aid the overall program objective in determining the impact of varying quality distillate fuel (with attendant varying thermal stability) on the fouling life of high-temperature components of engine fuel systems.

Therefore, such a facility has been designed and set up at SwRI and is described in detail in this report.

II. TEST FACILITY

A. General

Design and installation of a hot-fuel nozzle fouling facility was completed at SwRI in fiscal year 1984. The facility was designed to evaluate fuel flow divider valves and nozzles representative of those found in typical shipboard and aircraft turbine engines. System design requirements were determined from pertinent data obtained for various aircraft and shipboard use. Also system details are similar to those employed by General Electric, Evendale, OH. The details of the General Electric test facilities and procedures changed somewhat over the course of their testing programs, and the reader is referred to the project reports for specifics.(1-2,5-8) The various sections of the test facility are discussed in the following paragraphs.

B. Fuel Flow Section

Figure 2 illustrates the flow diagram of the hot-fuel nozzle test facility. Fuel enters from appropriate tankage as shown in the upper left corner of the illustration. It flows through the pump which is powered by a variable speed motor and controller to obtain the desired flow rate. A return leg in the flow system with a back-pressure regulator is employed to obtain the required fuel pressure. Behind the pump, two legs in the flow diagram contain filters and manually operated valves to direct flow through the desired filter. This arrangement allows changeout of a "plugged" filter element without stopping the test. Pressure gages are installed immediately in front of and behind the filters for determining pressure drop through the filter during operation. After the filters, there are three legs in the flow diagram. One contains a manually operated valve and each of the other two legs contains both a solenoid valve and a manually operated valve. The solenoid valves can be actuated through on/off recycle timers to obtain the desired flow rate through that leg for the fuel nozzle fouling cycle. The manual valves are employed to trim the flow rate in each leg to arrive at the total flow desired during each portion of the timed cycle.

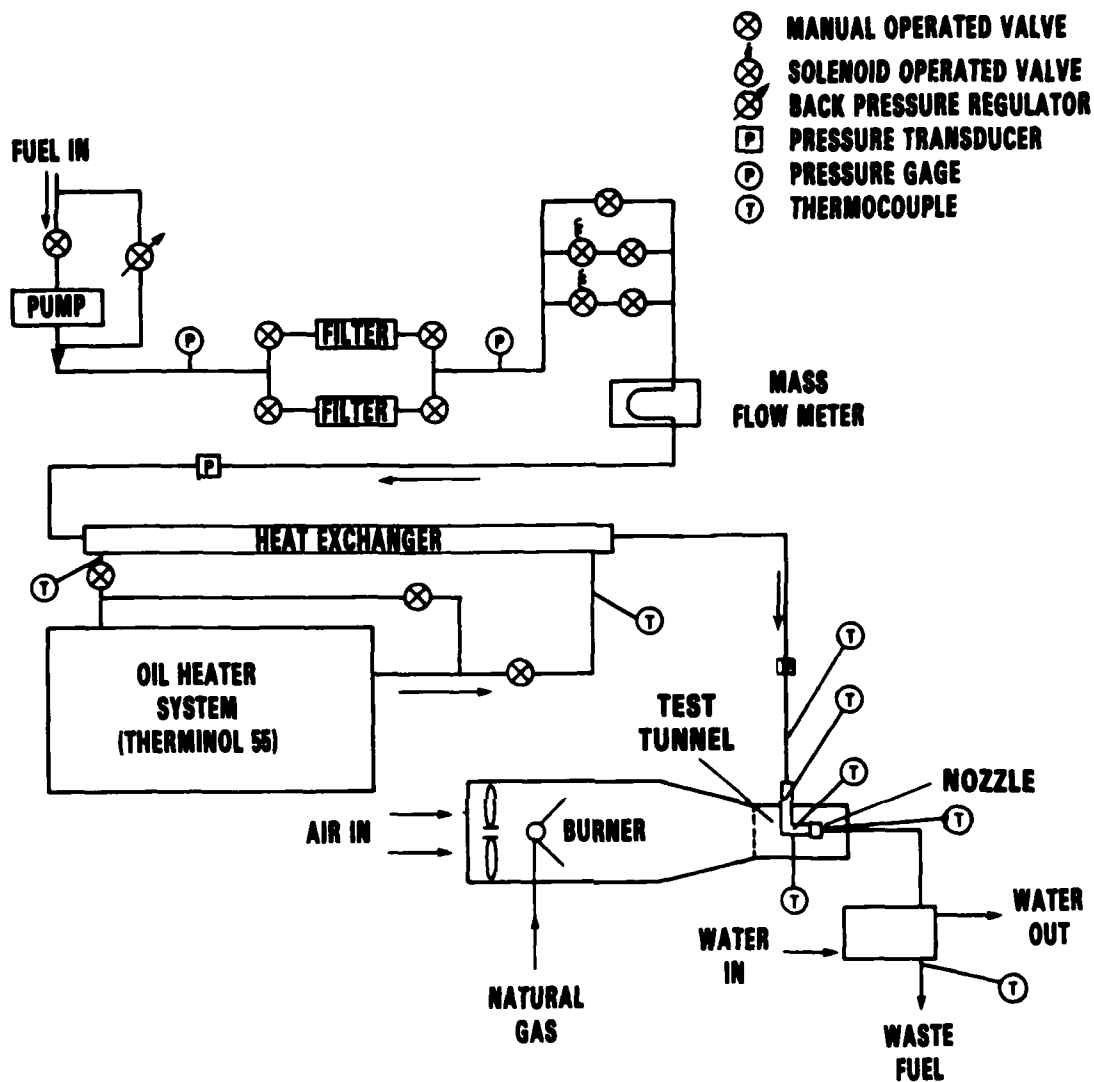

FIGURE 2. HOT-FUEL NOZZLE TEST FACILITY SCHEMATIC

A mass flowmeter using the vibrating tube technique for measuring fuel flow rate is plumbed into the facility as shown. This flowmeter, with the appropriate instrumentation, will give a digital readout of flow rate in lb/hr and also the total amount of flow from a preset time (totalizer). This type flowmeter is insensitive to changing fluid properties such as temperature, viscosity, pressure, density, etc., over a wide range. The waste fuel line is attached to the downstream side of the fuel nozzle and will gravity feed the waste fuel through a water-cooled plate coil heat exchanger to cool the fuel

below the flashpoint prior to dumping. It is imperative that the attachment between the fuel nozzle and the waste fuel line be leak free to prevent spraying of hot fuel into a highly ignitable area and creating a potentially dangerous fire.

C. Fuel Heating Section

A tube-in-tube, counterflow heat exchanger fabricated from stainless steel heats the fuel to the desired nozzle inlet-fuel temperature. Pressure transducers with digital readouts are located in front of and behind the heat exchanger. These are used to monitor fuel pressure drop in the heat exchanger. The downstream pressure transducer also provides the inlet-fuel pressure to the fuel nozzle being tested.

The oil heater system which supplies heating medium (oil) to the heat exchanger is shown in Figure 3 and is used to control the nozzle inlet-fuel temperature at the desired level over a range of values from ambient to 232°C (450°F). The oil heater system consists of an electric circulation heater, pump, pump motor, buffer and expansion tanks, solid-state power controller, and associated plumbing, electrical wiring, heat medium, etc., all mounted in a skid-base frame as shown in Figure 3. The heat medium in the system has an upper operational temperature limit of 316°C (600°F) and a flashpoint of 177°C (350°F).

The fuel heating system also has an immersion-type thermocouple located in the fuel line immediately in front of the nozzle. The fuel temperature indicated by this thermocouple is used to set the power controller in the oil heater system to control the nozzle inlet-fuel temperature at the desired level during testing. Also, where feasible, an immersion-type thermocouple is inserted in the nozzle stem or near the nozzle inlet screen (filter) for measuring temperature near the flow divider valve and/or atomizer as shown in Figure 2. Also shown in Figure 2, the outside of the nozzle stem or heat shield is instrumented with two welded-on surface temperature measuring thermocouples. One of these is a controlling thermocouple and the other is a recording thermocouple. The controlling thermocouple controls the heat input to the air heating system, which is discussed subsequently in this report. The heat input to the flowing air maintains the desired nozzle stem (metal) temperature during testing. When appropriate, a measuring thermocouple is also installed in the waste fuel line, downstream from the atomizer. This provides temperature data of the fuel immediately after exiting the atomizer, but

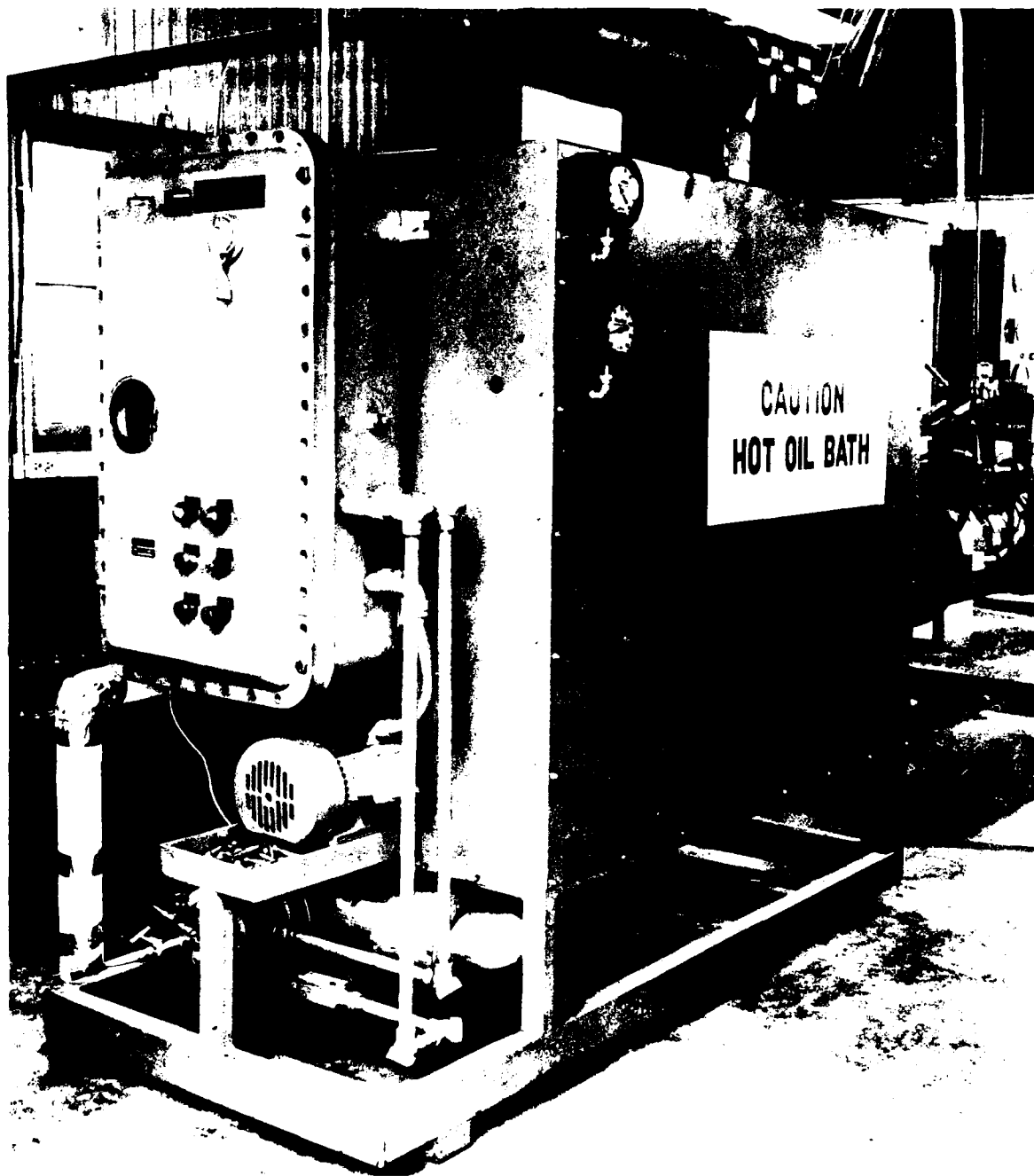

FIGURE 3. OIL HEATER SYSTEM FOR SUPPLYING HEAT MEDIUM TO OIL/FUEL HEAT EXCHANGER

prior to entering the "cooldown" heat exchanger. All of these temperatures, as measured by the various thermocouples, are permanently and continuously recorded on a multipoint stripchart recorder throughout a test. It should be noted that the fuel enters the "cooldown" heat exchanger from the nozzle directly through an enclosed shroud and does not interface with the hot air used to heat the nozzle. Therefore, the only parameter affecting nozzle deposition is the thermally induced stability characteristics of the fuel.

D. Air Heating Section

A photograph of the air heating section, with attached test tunnel, of the test facility is shown in Figure 4. Heating of the test tunnel air is provided by a natural gas fired burner enclosed in a burner tube. A double-shafted motor with both a volume fan and a combustion-air fan moves the air across the burner and down the tube where it proceeds through a partially insulated transformation duct and an insulated test tunnel. At the downstream end of the test tunnel, the heated air is exhausted back to atmosphere. The air heater is capable of up to 2600 scfm air flow and up to 1,000,000 Btu/hr heat release, with unrestricted air flow. On the other hand, these values may be reduced somewhat by employing an inlet air volume damper. Also, installation of the test tunnel at the downstream end of the air heater restricts the air flow through the system, depending on the cross-sectional size of the tunnel, and alters the heater's rated specifications somewhat. For this facility, a 14-cm x 19-cm (5.5-in. x 7.5-in.) rectangular-shaped test tunnel with an inside cross-sectional area of approximately 266 cm² (41.25 in.²) is employed. The air heater is automatically controlled by a proportioning temperature controller actuated by a welded-on surface thermocouple attached to the nozzle stem or heat shield at an appropriate location. Another welded-on surface thermocouple located immediately next to the controlling thermocouple is used to measure and record the nozzle stem (metal) temperature.

E. Test Tunnel Section

A photograph of the insulated test tunnel as attached to the air heating section of the test facility is shown in Figure 5. As seen in the photograph, the transformation duct connecting the air heating section and the test tunnel is also insulated approximately halfway back from the test tunnel. The air blast from the test tunnel exits through an opening in the wall of the facility building. The rectangular-shaped test tunnel has a

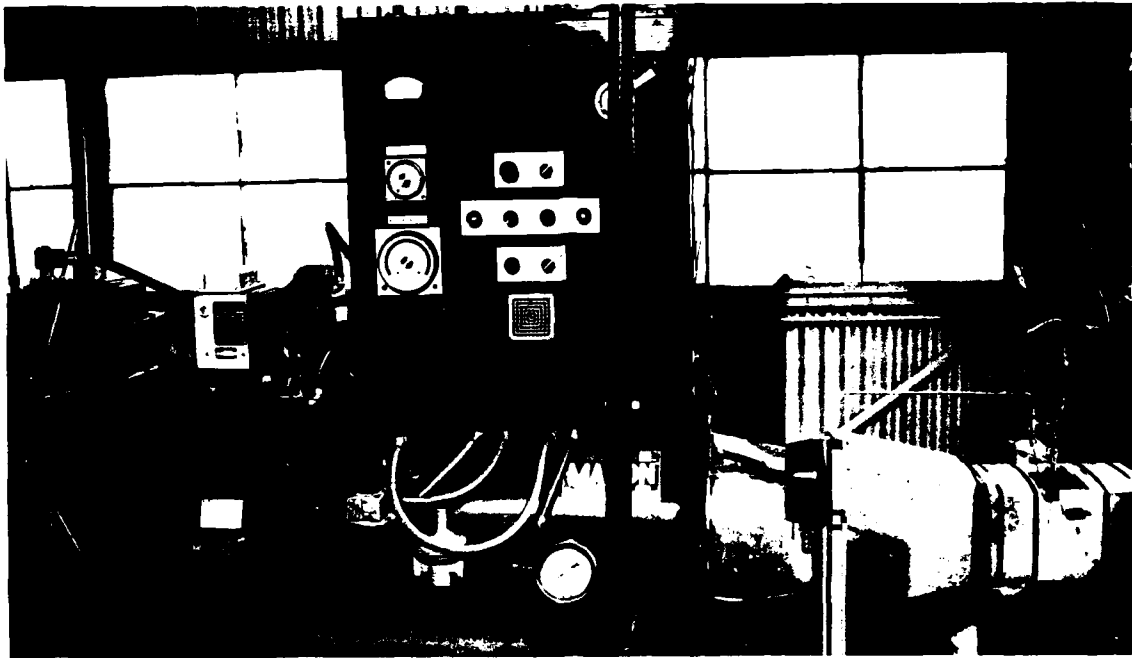

FIGURE 4. AIR HEATING SECTION OF TEST FACILITY WITH ATTACHED TEST FUNNEL

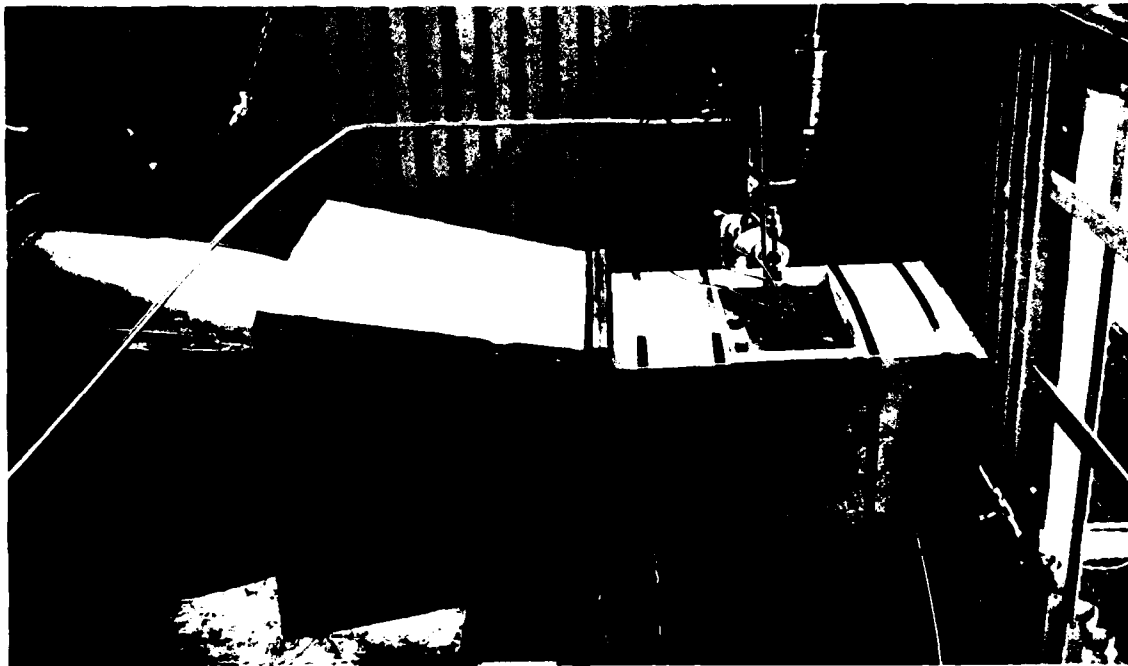

FIGURE 5. TEST TUNNEL SECTION OF TEST FACILITY WITH ATTACHING TRANSFORMATION DUCT

length of 38 cm (15 in.). The replaceable top plate, as shown in Figure 5 (the uninsulated plate attached by cap screws), is fabricated to accommodate the particular fuel nozzle being tested. The nozzle can easily be removed from the plate for calibration and/or inspection purposes. As seen, thermocouple lead conductors pass through the plate for instrumenting the nozzle with both controlling and recording thermocouples. Also shown is the nozzle inlet-fuel pressure measuring transducer discussed earlier in the report.

F. Test Capabilities

The hot-fuel nozzle fouling test facility has the following capabilities:

<u>Parameter</u>	<u>Capability</u>
Nozzle inlet-fuel temperature	Up to 232°C (450°F)*
Maximum fuel flow rate	200 lb/hr* (very low nozzle pressure)
Nozzle inlet fuel pressure	500 psig @ 90 lb/hr flow rate 250 psig @ 148 lb/hr flow rate 125 psig @ 175 lb/hr flow rate
Test tunnel air temperature (controls nozzle metal temperature)**	Up to 649°C (1200°F)

* The nozzle inlet-fuel temperature of 232°C (450°F) can be achieved at fuel flow rates considerably less than the maximum flow rate of 200 lb/hr. It is not known what inlet-fuel temperature can be achieved at the maximum flow rate because of the limited testing that has been performed using this facility.

** The fuel flow rate through the nozzle during testing also has an effect on nozzle metal temperature that is achieved.

The flow rate and pressure characteristics shown in the above table were obtained using Jet A fuel. The fuel supplied to the inlet pump from the storage tank was at ambient conditions. It should be realized that various fuels exhibiting different properties such as viscosity, density, lubricity, etc., will probably behave somewhat differently than the Jet A, thus altering the performance of the test facility.

The upper nozzle inlet fuel temperature limit of 232°C (450°F) was selected because this value should be well above that which would be expected for applications of interest in the near future. Also, previous work has shown that even fuels with high thermal stability breakpoints will give very short duration nozzle failures when tested at or above this temperature.

To avoid excessive temperatures in the fuel nozzle, fuel lines, or oil heater system during testing, the following startup and shutdown procedures are employed.

For Startup:

- (1) Turn on heater to hot oil section.
- (2) Turn on hot oil pump. Be sure to circulate heated oil through bypass plumbing, not through oil/fuel heat exchanger.
- (3) When oil temperature reaches desired level, open valve on fuel supply tank and actuate fuel flow through heat exchanger and nozzle.
- (4) When desired fuel flow is obtained, start hot oil flow through heat exchanger and stop oil flow through bypass.
- (5) Check for leaks of hot oil and/or fuel.
- (6) Actuate air blower and heater.
- (7) Adjust all sections to obtain desired flow rates and temperatures.

For Shutdown:

- (1) Record final test data readings.
- (2) Turn off hot oil heater.
- (3) Turn off hot air burner.
- (4) Open bypass valve in hot oil plumbing and close valve (hot oil) to oil/fuel heat exchanger.
- (5) After air heater section and test tunnel have cooled, turn off air blower.
- (6) After hot oil has been circulating through bypass plumbing for approximately 15 minutes, turn off hot oil pump.
- (7) Allow fuel to flow through oil/fuel heat exchanger until oil temperature has cooled to 79°C (175°F) or below.
- (8) Turn off fuel pump.

- (9) Close valve on fuel supply tank.
- (10) Remove fuel nozzle from test tunnel and inspect and/or recalibrate as appropriate.

III. TEST RESULTS

A shakedown test employing a No. 2 diesel fuel and a burner-type simplex swirl nozzle was performed. The breakpoint temperature of the fuel as determined by JFTOT was 238°C (461°F). Therefore, the fuel inlet temperature to the nozzle based on the breakpoint temperature was controlled at 207°-210°C (405°-410°F), which was believed would cause nozzle failure in less than 50 hours. The other testing conditions were as follows:

- Nozzle fuel flow rate - 40 lb/hr (18.1 kg/hr)
- Nozzle stem (metal) temperature - 285° to 291°C (545° to 555°F)

Since this was a simplex nozzle, the only criterion used to determine failure was a 10-percent reduction in orifice flow* at the testing flow rate. Figure 6 illustrates the reduction in orifice flow during testing, as determined by employing a calibration test stand. It is noted that failure occurred after 26 hours of testing (10-percent reduction in orifice flow), but the test was extended for another 4 hours to determine if orifice flow continued to decrease significantly and at a fairly constant rate. At 30 hours of testing, the flow reduction had reached 12.5 percent; therefore, the test was discontinued. On disassembly of the nozzle after testing and calibration, it was noted that the inlet screen (mesh not known) appeared to be partially plugged with significant deposits. Therefore, it was replaced with a new screen, and the nozzle flow calibration was again measured. Surprisingly, the new screen did not significantly alter the calibration results. Thus, it was concluded that the reduction in flow was indeed a result of orifice "plugging" and not screen "plugging".

Although these shakedown test data are somewhat meager, they do show that the test facility is functional and does provide a means for additional nozzle testing. Of course,

* 10-percent reduction in primary orifice flow is considered appropriate to determine a significant degradation in component performance without requiring excessive testing time. Accelerated tests are normally considered to have a maximum duration of 50 to 75 hours.

288°C Stem Temp; 40 lb/hr Fuel Flow

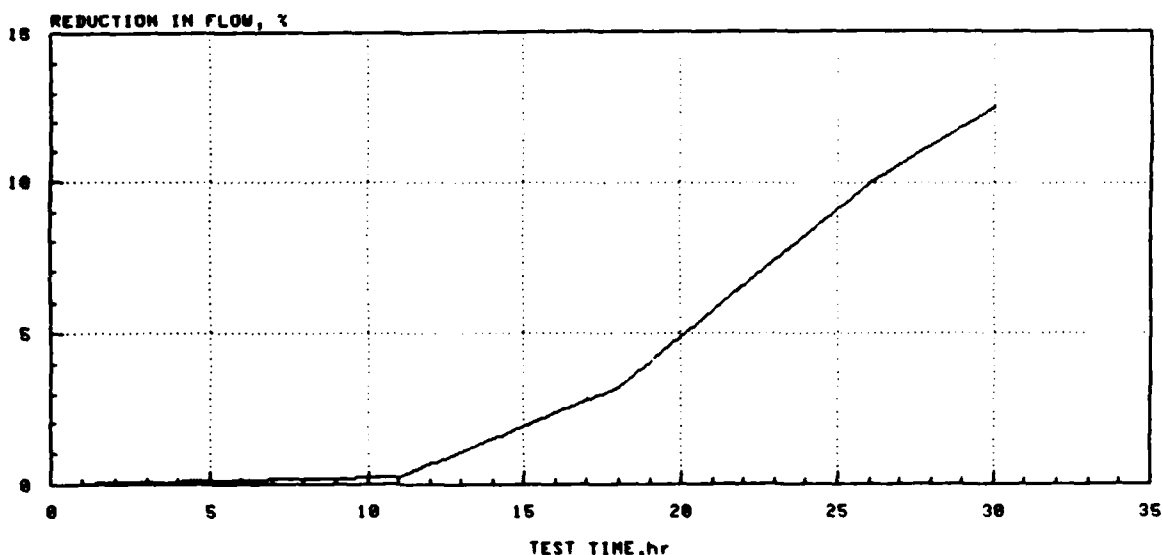

FIGURE 6. SIMPLEX NOZZLE FLOW CHARACTERISTICS USING NO. 2 DIESEL FUEL AT 210°C (410°F)

the actual capabilities of the facility will be known only after extensive additional testing has been accomplished.

IV. CONCLUSIONS AND RECOMMENDATIONS

The work discussed in this report only covers the design and installation of a test facility, with a very limited amount of shakedown testing; i.e., one 30-hour test. Therefore, the conclusions that can be drawn are very limited. It can be concluded, based on the one test, that a fuel nozzle test facility showing good testing potential has been developed and the facility needs to be employed to determine its full potential.

Based on the work covered in this report and the need for additional nozzle fouling test data on both specification and near-specification distillate fuels prior to qualifying such fuels for use in Navy shipboard gas turbine engines, the following program is recommended.

The major program effort would be to develop correlation equations, if feasible, relating JFTOT breakpoint temperature to the fouling life of flow divider valves and atomizing

nozzles. Each nozzle would be evaluated using three different fuels at three fuel temperatures for a total of nine determinations on each nozzle type. Where possible, fuel temperatures would be selected to limit the fouling test duration to a reasonable period of time (25 to 75 hours). The test fuels would be selected to cover a broad range of thermal stability. In other words, some fuels such as home heating oils have very low thermal stabilities, diesel fuels normally display intermediate thermal stabilities, and JP-5 has high thermal stability. These fuels can be mixed in various proportions to obtain the desired value if a fuel cannot be found having the proper characteristics. Determinations for each nozzle/fuel/temperature combination would be conducted until a "failure point" is reached, or until the preselected duration of the test has expired. Nozzle failure is defined as one of the following:

- A 10-percent reduction in primary orifice flow
- A 5-percent reduction in secondary orifice flow
- A 10-percent increase in hysteresis of the flow divider valve

These criteria are considered appropriate to cause a significant degradation in component performance without requiring excessive test time.

Nozzles to be evaluated in the fouling facility would be those for the GE LM2500, DDA 501-K17, and AVCO Lycoming TF40B engines. In the case of the DDA 501-K17, the original nozzle design has been modified to correct fouling problems encountered in the field. This nozzle would be evaluated in its configuration both before and after the redesign to determine if improved life can be demonstrated for the modified component. The fuel nozzles for this program would be supplied by the Navy as government-furnished equipment (GFE).

Three test fuels with different thermal stabilities would be obtained. The test fuels would be middle distillates. Thermal stability would be rated by the JFTOT breakpoint temperature. A range of breakpoint temperatures from 204° to 260°C (400°F to 500°F) would be desirable but not critical since it is difficult to secure fuels according to thermal stability.

Figure 7 illustrates the test matrix planned for the program, using the hot-fuel nozzle fouling facility. The four-nozzle by three-fuels by three-temperature matrix results in a total of 36 facility experiments.

	<u>GE</u> <u>LM2500</u>	<u>AVCO</u> <u>TF40B</u>	<u>DDA</u> <u>501-K17</u>	<u>DDA</u> <u>501-K17 Mod</u>
<u>Fuel 3</u>	<u>T3</u>	X	X	X
	<u>T2</u>	X	X	X
	<u>T1</u>	X	X	X
<u>Fuel 2</u>	<u>T3</u>	X	X	X
	<u>T2</u>	X	X	X
	<u>T1</u>	X	X	X
<u>Fuel 1</u>	<u>T3</u>	X	X	X
	<u>T2</u>	X	X	X
	<u>T1</u>	X	X	X

FIGURE 7. HOT-FUEL NOZZLE FOULING FACILITY TEST MATRIX

The anticipated results would be correlations between fuel JFTOT breakpoint temperatures and fouling tendencies of the fuels as determined using the hot-fuel nozzle fouling facility. Hopefully, correlations would permit development of impact statements to predict the fuel-limiting life expectancy of nozzles and metering valves for candidate fuel procurement.

V. REFERENCES

1. Gleason, C.C., et al., "Evaluation of Fuel Character Effects on J79 Smokeless Combustor," AFWAL-TR-80-2092, ESL-TR, 80-46, p. 178, November 1980.
2. Oller, T.L., et al., "Fuel Mainburner/Turbine Effects," AFWAL-TR-81-2100, May 1982.
3. Bahr, D.W. and Shayeson, M.W., "CRC-Aviation Group Meeting on Oxidation Stability of Gas Turbine Fuels," Alexandria, VA, 23-25 April 1984.
4. No author (Lestz, S.J., Principal Investigator), "Navy Hot Fuel Nozzle Fouling Studies. (DTNSRDC/NAPC)," Monthly Progress Report for period 1 August 1984 - 31 August 1984 (pp 9-12) on Basic and Applied Fuels and Lubricants Research, U.S. Army Fuels and Lubricants Research Laboratory, Southwest Research Institute, San Antonio, TX, Contract DAAK70-82-C-0001.
5. Gleason, C.C., et al., "Evaluation of Fuel Character Effects on J79 Engine Combustion System," AFAPL-TR-79-2015, June 1979.
6. Gleason, C.C., et al., "Evaluation of Fuel Character Effects on F101 Engine Combustion System," AFAPL-TR-79-2018, June 1979.
7. Morton, H.L., "Effects of Fuel Composition on Navy Aircraft Engine Hot Components," NAPC-PE-117C, December 1983.
8. Moses, C., et al., "Development of an Alternate Test Procedure to Quality Fuels for Navy Aircraft, Phase II," NAPC-PE-145C, August 1984.

DISTRIBUTION LIST

DEPARTMENT OF DEFENSE

DEFENSE DOCUMENTATION CTR
CAMERON STATION 12
ALEXANDRIA VA 22314

DEPT. OF DEFENSE
ATTN: OASD (A&L) (MR DYCKMAN) 1
WASHINGTON DC 20301-8000

CDR
DEFENSE FUEL SUPPLY CTR
ATTN: DFSC-Q (MR MARTIN) 1
CAMERON STATION
ALEXANDRIA VA 22304-6160

DOD
ATTN: DUSDRE (RAT) (Dr. Dix) 1
ATTN: ROOM 3-D-1089, PENTAGON 1
WASHINGTON DC 20301

DEFENSE ADVANCED RES PROJ
AGENCY
DEFENSE SCIENCES OFC 1
1400 WILSON BLVD
ARLINGTON VA 22209

DEPARTMENT OF THE ARMY

HG, DEPT OF ARMY
ATTN: DALO-TSE (COL BLISS) 1
DALO-AV 1
DAMO-FDR (MAJ KNOX) 1
DAMA-ARZ (DR CHURCH) 1
DAMA-ART (LTC RINEHART) 1
WASHINGTON DC 20310

CDR
U.S. ARMY BELVOIR RESEARCH,
DEVELOPMENT & ENGINEERING CTR
ATTN: STRBE-VF 10
STRBE-WC 2
FORT BELVOIR VA 22060-5606

CDR
US ARMY MATERIEL DEVEL &
READINESS COMMAND
ATTN: AMCLD (DR ODOM) 1
AMCDE-SG 1
AMCDE-SS 1
AMCQA-E 1
AMCSM-WST (LTC DACEY) 1
5001 EISENHOWER AVE
ALEXANDRIA VA 22333-0001

CDR
US ARMY TANK-AUTOMOTIVE CMD
ATTN: AMSTA-RG (MR WHEELOCK) 1
AMSTA-TSL (MR BURG) 1
AMSTA-G 1
AMSTA-MTC (MR GAGLIO),
AMSTA-MC, AMSTA-MV 1
AMSTA-UBP (MR MCCARTNEY) 1
AMSTA-MLF (MR KELLER) 1
WARREN MI 48397-5000

DIRECTOR
US ARMY MATERIEL SYSTEMS
ANALYSIS ACTIVITY
ATTN: AMXSY-CM (MR NIEMEYER) 1
AMXSY-CR 1
ABERDEEN PROVING GROUND MD
21005-5006

DIRECTOR
APPLIED TECHNOLOGY LAB
U.S. ARMY R&T LAB (AVSCOM)
ATTN: SAVDL-ATL-ATP (MR MORROW) 1
SAVDL-ATL-ASV 1
FORT EUSTIS VA 23604-5577

CDR
US ARMY GENERAL MATERIAL &
PETROLEUM ACTIVITY
ATTN: STRGP-F (MR ASHBROOK) 1
STRGP-FE, BLDG 85-3 1
STRGP-FT 1
NEW CUMBERLAND PA 17070-5008

HQ, DEPT. OF ARMY ATTN: DAEN-DRM WASHINGTON DC 20310	1	CDR US ARMY EUROPE & SEVENTH ARMY ATTN: AEAGG-FMD AEAGD-TE APO NY 09403	1 1
CDR US ARMY RES & STDZN GROUP (EUROPE) ATTN: AMXSN-UK-RA (DR OERTEL) AMXSN-UK-SE (LTC NICHOLS) BOX 65 FPO NEW YORK 09510	1 1	CDR THEATER ARMY MATERIAL MGMT CENTER (200TH)-DPGM DIRECTORATE FOR PETROL MGMT ATTN: AEAGD-MMC-PT-Q APO NY 09052	1 1
CDR, US ARMY AVIATION R&D CMD ATTN: AMSAV-EP (MR EDWARDS) AMSAV-NS 4300 GOODFELLOW BLVD ST LOUIS MO 63120-1798	1 1	CDR US ARMY RESEARCH OFC ATTN: SLCRO-ZC SLCRO-EG (DR MANN) SLCRO-CB (DR GHIRARDELLI) P O BOX 12211 RSCH TRIANGLE PARK NC 27709-2211	1 1 1 1
CDR US ARMY FORCES COMMAND ATTN: AFLG-REG AFLG-POP FORT MCPHERSON GA 30330	1 1	PROG MGR, TACTICAL VEHICLE ATTN: AMCPM-TV WARREN MI 48397	1 1
CDR US ARMY YUMA PROVING GROUND ATTN: STEYP-MT-TL-M (MR DOEBBLER) YUMA AZ 85364-9130	1	DIR US ARMY AVIATION R&T LAB (AVSCOM) ATTN: SAVDL-AS (MR WILSTEAD) AMES RSCH CTR MAIL STOP 207-5 MOFFET FIELD CA 94035	1 1
PROJ MGR, BRADLEY FIGHTING VEHICLE SYS ATTN: AMCPM-FVS-M WARREN MI 48397	1	CDR TRADOC COMBINED ARMS TEST ACTIVITY ATTN: ATCT-CA FORT HOOD TX 76544	1 1
PROG MGR, M113 FAMILY OF VEHICLES ATTN: AMCPM-M113-T WARREN MI 48397	1	HQ, EUROPEAN COMMAND ATTN: J4/7-LJPO (LTC LETTERIE) VAIHINGEN, GE APO NY 09128	1 1
PROJ MGR, MOBILE ELECTRIC POWER ATTN: AMCPM-MEP-TM 7500 BACKLICK ROAD SPRINGFIELD VA 22150	1	CDR US ARMY GENERAL MATERIAL & PETROLEUM ACTIVITY ATTN: STRGP-FW (MR PRICE) BLDG 247, DEFENSE DEPOT TRACY TRACY CA 95376	1 1
PROJ OFF, AMPHIBIOUS AND WATER CRAFT ATTN: AMCPM-AWC-R 4300 GOODFELLOW BLVD ST LOUIS MO 63120	1		

PROJ MGR, LIGHT ARMORED VEHICLES ATTN: AMCPM-LA-E WARREN MI 48397	1	DIRECTOR US ARMY RSCH & TECH LAB (AVSCOM) PROPULSION LABORATORY ATTN: SAVDL-PL-D (MR ACURIO) 21000 BROOKPARK ROAD CLEVELAND OH 44135-3127	1
CDR US ARMY FOREIGN SCIENCE & TECH CENTER ATTN: AMXST-MT-1 AMXST-BA	1 1	CDR US ARMY NATICK RES & DEV LAB ATTN: STRNA-YE (DR KAPLAN) STRNA-U	1 1
FEDERAL BLDG CHARLOTTESVILLE VA 22901		NATICK MA 01760-5000	
PROJECT MANAGER, LIGHT COMBAT VEHICLES ATTN: AMCPM-LCV-TC WARREN, MI 48397	1	PROJ MGR, PATRIOT PROJ OFFICE ATTN: AMCPM-MD-T-C U.S. ARMY MISSILE COMMAND REDSTONE ARSENAL AL 35898	1
HQ, US ARMY T&E COMMAND ATTN: AMSTE-TO-O AMSTE-CM-R-O AMSTE-TE-T (MR RITONDO)	1 1 1	CDR US ARMY QUARTERMASTER SCHOOL ATTN: ATSM-CD ATSM-TD ATSM-PFS	1 1 1
ABERDEEN PROVING GROUND MD 21005-5006		FORT LEE VA 23801	
CDR, US ARMY TROOP SUPPORT COMMAND ATTN: AMSTR-ME AMSTR-S AMSTRE-E	1 1 1	HQ, US ARMY ARMOR CENTER AND FORT KNOX ATTN: ATSB-CD	1
4300 GOODFELLOW BLVD ST LOUIS MO 63120-1798		FORT KNOX KY 40121	
CDR CONSTRUCTION ENG RSCH LAB ATTN: CERL-EM CERL-ZT CERL-EH	1 1 1	CDR 101ST AIRBORNE DIV (AASLT) ATTN: AFZB-KE-J AFSB-KE-DMMC	1 1
P O BOX 4005 CHAMPAIGN IL 61820		FORT CAMPBELL KY 42223	
TRADOC LIAISON OFFICE ATTN: ATFE-LO-AV	1	CDR US ARMY WESTERN COMMAND ATTN: APLG-TR	1
4300 GOODFELLOW BLVD ST LOUIS MO 63120-1798		FORT SCHAFTER HI 96858	
HQ US ARMY TRAINING & DOCTRINE CMD ATTN: ATCD-SL-5 (MAJ JONES)	1	CDR COMBINED ARMS COMBAT DEVELOPMENT ACTIVITY ATTN: ATZL-CAT-E ATZL-CAT-A	1 1
FORT MONROE VA 23651-5000		FORT LEAVENWORTH KA 66027-5300	

CDR
US ARMY LOGISTICS CTR
ATTN: ATCL-MS (MR A MARSHALL) 1
ATCL-C 1
FORT LEE VA 23801-6000

PROJECT MANAGER
PETROLEUM & WATER LOGISTICS
ATTN: AMCPM-PWS 1
4300 GOODFELLOW BLVD
ST LOUIS MO 63120-1798

CDR
US ARMY AVIATION CTR & FT RUCKER
ATTN: ATZQ-DI 1
FORT RUCKER AL 36362

PROG MGR, TANK SYSTEMS
ATTN: AMCPM-MIE1-SM 1
AMCPM-M60 1
WARREN MI 48397

CDR
US ARMY ARMOR & ENGINEER BOARD
ATTN: ATZK-AE-AR 1
ATZK-AE-LT 1
FORT KNOX KY 40121

CDR
6TH MATERIEL MANAGEMENT CENTER
19TH SUPPORT BRIGADE
APO SAN FRANCISCO 96212-0172

CDR
US ARMY SAFETY CENTER
ATTN: PESC-SSD (MR BUCHAN) 1
FORT RUCKER AL 36362

DEPARTMENT OF THE NAVY

CDR
NAVAL AIR PROPULSION CENTER
ATTN: PE-33 (MR D'ORAZIO) 1
P O BOX 7176
TRENTON NJ 06828

CDR
NAVAL SEA SYSTEMS CMD
ATTN: CODE 05M4 (MR R LAYNE) 1
WASHINGTON DC 20362-5101

CDR
DAVID TAYLOR NAVAL SHIP R&D CTR
ATTN: CODE 2830 (MR BOSMAJIAN) 1
CODE 2759 (MR STRUCKO) 10
CODE 2831 1
ANNAPOLIS MD 21402

CDR
NAVAL SHIP ENGINEERING CENTER
ATTN: CODE 6764 1
PHILADELPHIA PA 19112

PROJ MGR, M60 TANK DEVELOPMENT
ATTN: USMC-LNO 1
US ARMY TANK-AUTOMOTIVE
COMMAND (TACOM)
WARREN MI 48397

DEPARTMENT OF THE NAVY
HQ, US MARINE CORPS
ATTN: LPP 1
LMM/2 1
WASHINGTON DC 20380

CDR
NAVAL AIR SYSTEMS CMD
ATTN: CODE 53645 (MR MEARNES) 1
WASHINGTON DC 20361

CDR
NAVAL RESEARCH LABORATORY
ATTN: CODE 6170 1
CODE 6180 1
WASHINGTON DC 20375

CDR
NAVAL FACILITIES ENGR CTR
ATTN: CODE 1202B (MR R BURRIS) 1
200 STOVAL ST
ALEXANDRIA VA 22322

CDR
NAVAL AIR ENGR CENTER
ATTN: CODE 92727 1
LAKEHURST NJ 08733

COMMANDING GENERAL
US MARINE CORPS DEVELOPMENT
& EDUCATION COMMAND
ATTN: DO74 (LTC WOODHEAD) 1
QUANTICO VA 22134

OFFICE OF THE CHIEF OF NAVAL
RESEARCH

ATTN: OCNR-126 (MR ZIEM) 1
ARLINGTON, VA 22217-5000

CHIEF OF NAVAL OPERATIONS
ATTN: OP 413 1
WASHINGTON DC 20350

CDR
NAVY PETROLEUM OFC
ATTN: CODE 43 (MR LONG) 1
CAMERON STATION
ALEXANDRIA VA 22314

DEPARTMENT OF THE AIR FORCE

HQ, USAF
ATTN: LEYSF 1
WASHINGTON DC 20330

HQ AIR FORCE SYSTEMS CMD
ATTN: AFSC/DLF 1
ANDREWS AFB MD 20334

CDR
US AIR FORCE WRIGHT AERONAUTICAL
LAB
ATTN: AFWAL/POSF (MR CHURCHILL) 1
WRIGHT-PATTERSON AFB OH 45433

CDR
SAN ANTONIO AIR LOGISTICS
CTR
ATTN: SAALC/SFT (MR MAKRIS) 1
SAALC/MMPRR 1
KELLY AIR FORCE BASE TX 78241

CDR
DET 29
ATTN: SA-ALC/SFM 1
CAMERON STATION
ALEXANDRIA VA 22314

OTHER GOVERNMENT AGENCIES

NATIONAL AERONAUTICS AND
SPACE ADMINISTRATION
VEHICLE SYSTEMS AND ALTERNATE
FUELS PROJECT OFFICE
ATTN: MR CLARK 1
LEWIS RESEARCH CENTER
CLEVELAND OH 44135

DEPARTMENT OF TRANSPORTATION
FEDERAL AVIATION ADMINISTRATION
ATTN: AWS-110 1
800 INDEPENDENCE AVE, SW
WASHINGTON DC 20590

US DEPARTMENT OF ENERGY
CE-151
ATTN: MR ECKLUND 1
FORRESTAL BLDG.
1000 INDEPENDENCE AVE, SW
WASHINGTON DC 20585

END

12-86

DTIC