

AD-A173 858

SPRAY DEPOSITION: A FUNDAMENTAL STUDY OF DROPLET
IMPINGEMENT SPREADING AND (U) DREXEL UNIV PHILADELPHIA
PA DEPT OF MATERIALS ENGINEERING D APELIAN ET AL

1/1

UNCLASSIFIED

01 SEP 86 TR-2 N00014-84-K-0472

F/G 11/6

NL

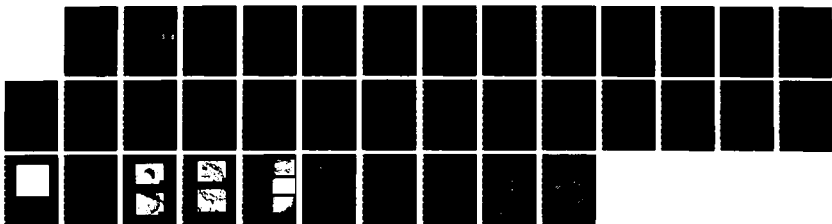

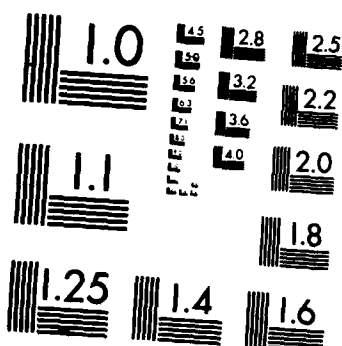

MICROCOPY RESOLUTION TEST CHART
 NATIONAL BUREAU OF STANDARDS-1963-A

2

AD-A173 858

Technical Report No. 2

Contract N 00014-84-K-0472; NR 650-025

SPRAY DEPOSITION : A FUNDAMENTAL STUDY OF DROPLET IMPINGEMENT, SPREADING AND CONSOLIDATION

D. Apelian, A. Lawley, G. Gillen and P. Mathur.
Department of Materials Engineering
Drexel University
Philadelphia, PA 19104

DTIC
ELECTE
NOV 03 1986
S D

1 September 1986

Annual Report for Period 1 July 1985 - 30 June 1986

Approved for public release; distribution unlimited. Reproduction in whole or in part is permitted for any purpose of the United States government.

Prepared for
OFFICE OF NAVAL RESEARCH
800 N. Quincy Street
Arlington VA 22217

DTIC FILE COPY

TABLE OF CONTENTS

ABSTRACT	3
1. INTRODUCTION	4
2. RESEARCH APPROACH	4
3. THEORETICAL STUDIES	5
3.1 Droplet Velocity	5
3.2 Droplet Temperature	6
3.3 Droplet Consolidation	7
4. EXPERIMENTAL RESULTS AND DISCUSSION	11
4.1 Droplet Velocity	11
4.2 Droplet Solidification: Glass Slide Experiments	11
4.3 Preform Deposits	11
4.4 Spray Deposition Process Parameters	12
4.5 Microstructural Refinement via Spray Deposition	13
5. CONCLUSIONS	14
6. FUTURE PLANS	15
REFERENCES	16
APPENDIX 1	17
FIGURES, TABLES	



Accession For	
NTIS CRA&I	<input checked="" type="checkbox"/>
DTIC TAB	<input type="checkbox"/>
Unannounced	<input type="checkbox"/>
Justification	
By	
Distribution/	
Availability Codes	
Dist	Avail and/or Special
A-1	

ABSTRACT

✓
In spray deposition via the Osprey process a stream of molten metal is atomized by an inert gas to form a spray of liquid droplets. The droplets are cooled by the atomizing gas and accelerated towards a substrate where they consolidate to form a thick deposit. Current research at Drexel University^g is directed towards a fundamental science-based understanding of the spray deposition process^{and}. ~~This research~~ involves both theoretical and experimental studies. A computer model of the spray deposition process has been developed to predict velocity and temperature profiles of the metal droplets in flight. This model takes into account the undercooling and solidification of the droplets. Another computer model has been developed to predict how the droplets spread and consolidate upon impingement with the substrate. Experiments have been^{designed} designed to verify the predictions made by the two models and also to determine the most influential spray deposition process parameters. Short-exposure still photography has been used to estimate droplet velocities. To study the extent of solidification of individual droplets, glass slides have been traversed through the metal spray.

✓

1. INTRODUCTION

In spray deposition via the Osprey process [1,2] a stream of molten metal is atomized by an inert gas to form a spray of liquid droplets (Figure 1). The liquid droplets are cooled by the atomizing gas and accelerated towards a substrate where they consolidate to form a thick deposit. The major advantage of this process is that a rapidly solidified, near-net shaped product can be fabricated in a single operation directly from the melt. This leads to significant energy savings and increased cost efficiency. The spray deposition technology evolved from powder atomization but improves on P/M processing in that powder handling is eliminated. This ONR report describes and updates current research at Drexel University.

2. RESEARCH APPROACH

The research is directed towards a fundamental science-based understanding of the spray deposition process and involves both theoretical and experimental studies. An outline of the research approach is given overleaf. A computer model has been developed which predicts the velocity and temperature profiles of the liquid droplets in flight. The model takes into account the undercooling and solidification of the droplets. Another computer model has been developed to predict how the droplets spread and consolidate upon impingement with the substrate. Experiments have been designed to verify the predictions made by the two computer models, respectively. The microstructure and density of the final product are determined by the condition of the droplets prior to impingement with the substrate. Spray deposition process parameters such as melt superheat, metal flow rate, atomizing gas pressure and flight distance control the condition of the metal droplets. Experiments have been designed to determine which are the most influential spray deposition process parameters. A description of Drexel's spray deposition equipment is given in Appendix 1. Further details are available in a previous ONR report [3].

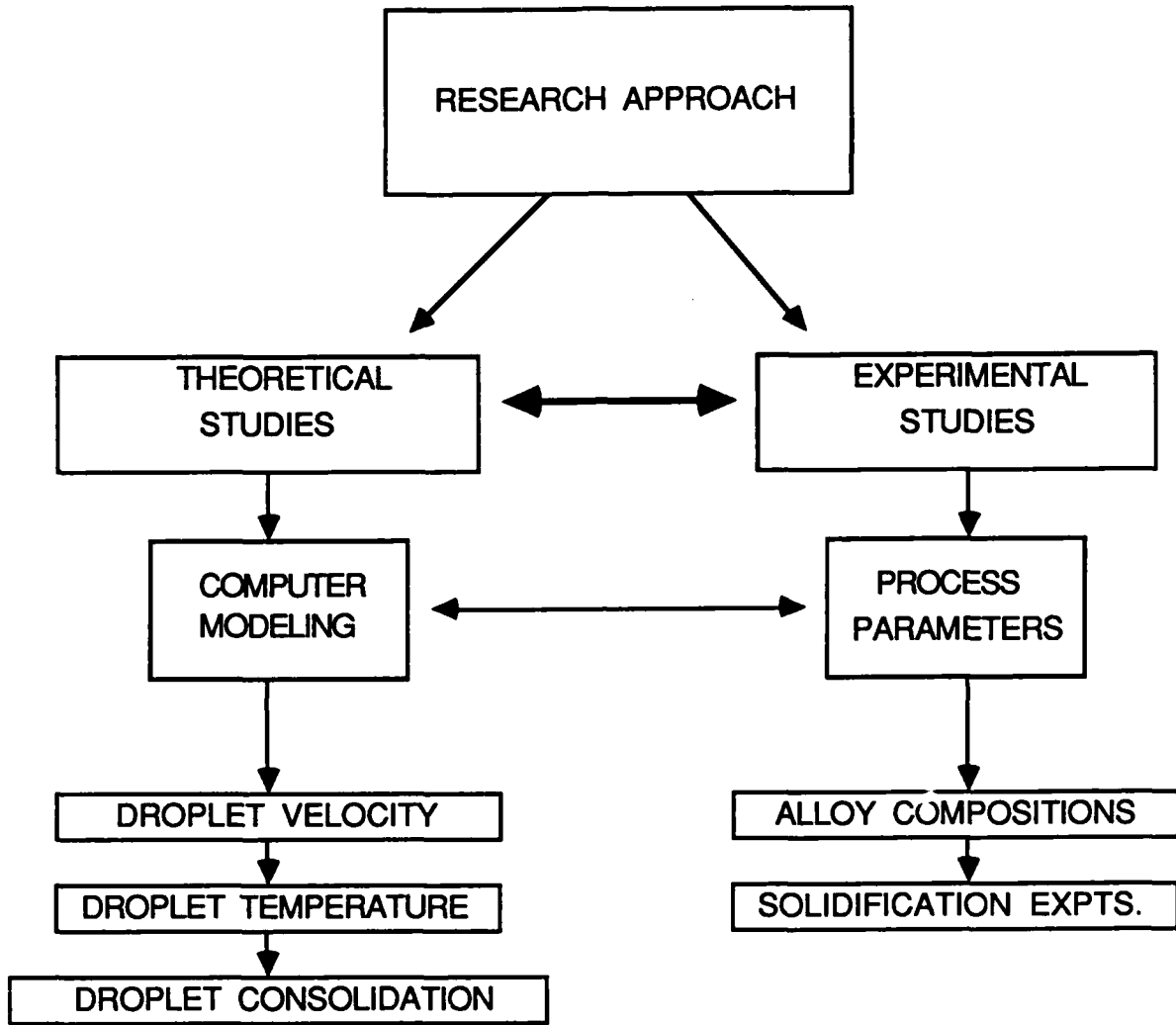

FLOW CHART ILLUSTRATING THE RESEARCH APPROACH

3. THEORETICAL STUDIES

The spray comprises of a range of droplet diameters, and the model analyzes a single droplet diameter at a time to determine the velocity and temperature profiles along its flight trajectory. The model is then run for representative droplet diameters that cover the entire size range. The objective is to predict the condition of the droplets prior to impact at the substrate. Mean droplet size d_m and standard deviation σ have been determined experimentally.

3.1 Droplet Velocity

Individual droplets are treated as spheres of diameter d and are assumed to follow a linear trajectory in flight. The velocity profile is determined from the momentum equation, which relates the acceleration of a droplet to the velocity of the gas relative to the droplet ($V_r = V_g - V_d$):

$$\frac{dV_d}{dt} = \frac{3}{4} \frac{C_D}{d} \frac{\rho_g}{\rho_d} (V_g - V_d) |V_g - V_d| + g \quad \dots\dots\dots (1)$$

where, V is velocity, t is time, C_D is the drag coefficient, d is the droplet diameter, ρ is density and g is the acceleration due to gravity. The subscripts g and d refer to the gas and droplet, respectively. The expression for the drag coefficient, C_D , has been taken from Kurten et al [4], since it is applicable for a wide range of Reynolds numbers ($0.1 < Re < 4000$) with a small deviation ($\pm 7\%$) from the standard drag curve:

$$C_D = 0.28 + \frac{6}{(Re)^{0.5}} + \frac{21}{Re} \quad \dots\dots\dots (2)$$

$$Re = \frac{V_r d}{\nu} \quad \dots\dots\dots (3)$$

where ν is the kinematic viscosity of the gas. Equation (1) is solved numerically at nodes along the flight trajectory. Figure 2 shows the predicted variation of droplet velocity with

flight distance for Ni-20 wt.%Cr droplets. The mean droplet diameter is 80 μm . From the point of atomization, the droplet velocity increases up to a maximum value (peak velocity), and then decreases. Smaller droplets attain higher peak velocities, and in general travel faster than larger ones at a given flight distance as shown in Figure 3.

3.2 Droplet Temperature

The heat transfer between the droplet and the surrounding atomizing gas is assumed to be interface controlled since the Biot number ($Bi = hd / k_d$) is smaller than 0.1. The heat transfer coefficient is computed from the empirical expression by Ranz and Marshall [5] :

$$Nu = \frac{hd}{k_g} = 2 + 0.6 Re^{0.5} Pr^{0.33} \dots\dots\dots(4)$$

where, Nu is the Nusselt number, h is the heat transfer coefficient, k_g is the thermal conductivity of the gas and Pr is the Prandtl number which equals $C_g \mu_g / k_g$. C_g is the specific heat and μ_g is the viscosity. The Reynolds number is known from the model for a given droplet velocity. Correction factors are included to account for the temperature of the gas immediately neighboring the droplet as compared to the bulk [6].

The degree of undercooling present in the droplet will also influence its temperature profile. We consider two extremes of undercooling:

1. **No undercooling with heterogeneous nucleation.**
2. **Large undercooling with homogeneous nucleation.**

For the case of no undercooling the temperature profiles for three droplet diameters are shown in Figure 4. The extent of solidification for a range of droplet sizes is shown in Figure 5. For example, at a flight distance of 50 mm, droplets smaller than 40 μm are predicted to be completely solidified ($f_s = 1$) while larger droplets are partially solidified. If d^* is the size of the largest solidified droplet at a given flight distance, then d^* increases from 40 μm (at 50 mm) to 100 μm (at 300 mm).

The other extreme of droplet undercooling is determined by assuming homogeneous nucleation. The corresponding temperature profiles are shown in Figure 6.

In Figure 7 we see that d^* increases from 35 μm (at 100 mm) to 75 μm (at 400 mm), and there is a clear demarcation between solidified and liquid droplets.

The two extremes of the degree of undercooling predict widely different temperature profiles. Moreover, either case is unlikely. It is conceivable to think of droplets nucleating heterogeneously at a fraction of the undercooling estimated from homogeneous nucleation theory. Therefore,

$$\Delta T = f \Delta T^C \quad \text{.....(5)}$$

where ΔT is the undercooling at fraction f of ΔT^C which is the required undercooling for homogeneous nucleation. f can be varied between 0 (no undercooling) and 1 (homogeneous nucleation). Figure 8 is the predicted effect of f on the solidification behavior of an 80 μm droplet. For example, if $f = 0.5$ then at least 70% of the 80 μm droplet would be solidified after a flight distance of 75 mm. When $f = 0.8$ all 80 μm droplets would be expected to be completely solidified after 240 mm.

3.3 Droplet Consolidation

The ability to predict and control the spreading kinetics of droplets impacting on a preform will help to optimize the consolidation process in spray deposition. Considering that a single droplet splatting onto a surface is the fundamental unit of this type of consolidation, it is important to understand the process of how the controlling variables affect energy dissipation and consequently the final morphology of the splat. The mechanism of droplet splatting is one in which a nearly spherical droplet of liquid, or partially resolidified material, dissipates kinetic energy to viscous work and the creation of high curvature surfaces.

The hostile environment of the metal spray chamber along with the high droplet impact velocity and spray density make direct observation of the droplet splatting phenomenon impractical, if not impossible. The only direct information obtainable from the process is the droplet velocity distribution and final splat shape, i.e., thickness via microscopic examination. What is needed is a method of predicting the spreading behavior along with the final shape of the splats which will be subsequently confirmed by experiments with model systems. A computer program called S.P.L.A.S.H. (Simulation of Particles Landing At their Substrate Habitat) was developed for this specific problem. By using this model, one may study the combined effects of various material properties and

process conditions on the terminal splat shape in order to optimize the conditions for a particular material and application.

A review of various modeling techniques available revealed that the free surface boundary condition, which is involved in the flow throughout spreading, greatly complicates the problem. The best technique found for this particular application is a primitive-variable formulation of velocity and pressure (U-V-P), which provides a time dependent solution of the Navier Stokes equations for free surface flows.

$$\rho \frac{DV}{Dt} = \rho g_i - \nabla p + \mu \nabla^2 V \quad \dots\dots\dots(6)$$

where,

- | | |
|-----------------------------|-----------------------------|
| ρ = density of droplet | g_i = gravitational force |
| V = 3 - D velocity | p = pressure |
| μ = viscosity | |

This method employs a Eulerian mesh (Figure 9) through which fluid flows under the influence of the surrounding pressure field. The solution proceeds by marching through time in discrete intervals; solving all the fluid flow and heat transfer equations at each time step. Assuming the pressure and velocity fields at a given point in time are known, the solution of the next time step is as follows:

- 1) Compute a tentative velocity field for the new time level from the previous time level pressure of velocity fields using the Navier Stokes equations.
- 2) Apply the boundary conditions at all fixed and free boundaries.
- 3) Solve for the pressure field from the tentatively calculated velocity field.
- 4) Iteratively adjust velocity and pressure fields to satisfy continuity in each mesh cell until solution is converged. Update boundary conditions during each iteration.
- 5) Move fluid to conform with the calculated velocity field.
- 6) Advance to next time cycle.

Figure 10 shows the essential features of a splatting droplet [7]. The droplets are impacting perpendicularly to the substrate surface and each droplet spreads out nearly uniformly in the radial direction, resulting in a thin pancake-like splat. Therefore, to simplify the solution procedure, symmetry about the centerline of the droplet is assumed.

The problem is then solved in the two spatial dimensions of radius and height. Another simplifying assumption used in the model is that laminar flow is assumed to prevail throughout the fluid field. This assumption is justified by the fact that the actual flow conditions span the nebulous range of the transition from the laminar to turbulent flow regimes. Initially, the assumption of laminar flow will be used. If, however, deviations from the experimental results are noted, some type of turbulence model may be included. Solidification in the droplet from partially solidified droplet impingement or in-situ solidification is modeled as a local viscosity change varying as a function of fraction solid. Because certain locations along the free surface, i.e., the outer rim will exhibit a very high curvature, the resultant interfacial energy is applied as a surface pressure. This force is computed from the local curvature as defined by the marker particles along that area of the surface. Typically, in this type of model, this effect introduces an appreciable quantity of numerical "noise", resulting in slow convergence rates in each time step of the simulation. This problem is not expected to occur with the present method of free surface marker particles due to the smooth surface which they define. The flow sheet for the S.P.L.A.S.H. model is given overleaf.

To facilitate the development of the model, we started with an existing program (SOLA-VOF) and modified it to suit our needs. Much modification and optimization was required for the simulation of splatting. The result of these extensive changes was a new program code dedicated to free surface, high deformation flows. The runnable version of the program, however, took far too much computational time - even after much computational optimization. Before optimization, the estimated time to run a single simulation was measured in years on the IBM 3081 main frame computer. After optimization, including the development of an automatic grid modification system (needed because of the large dimensional changes in going from a spherical droplet to a thin pancake-like splat) the time was reduced to a few weeks on our Prime 9955 super-mini computer.

A large quantity of supercomputer (CRAY) time was made available at Los Alamos National Laboratory to be used for droplet consolidation research. Using these super computers the simulation requires only about an hour of processing time; thus making the model a viable research tool.

The current status of the modelling work is that the model is in its final stages of development and preliminary versions of it are running on the computers at Los Alamos for special test cases. We are grateful to Los Alamos Laboratories and particularly Drs. S.

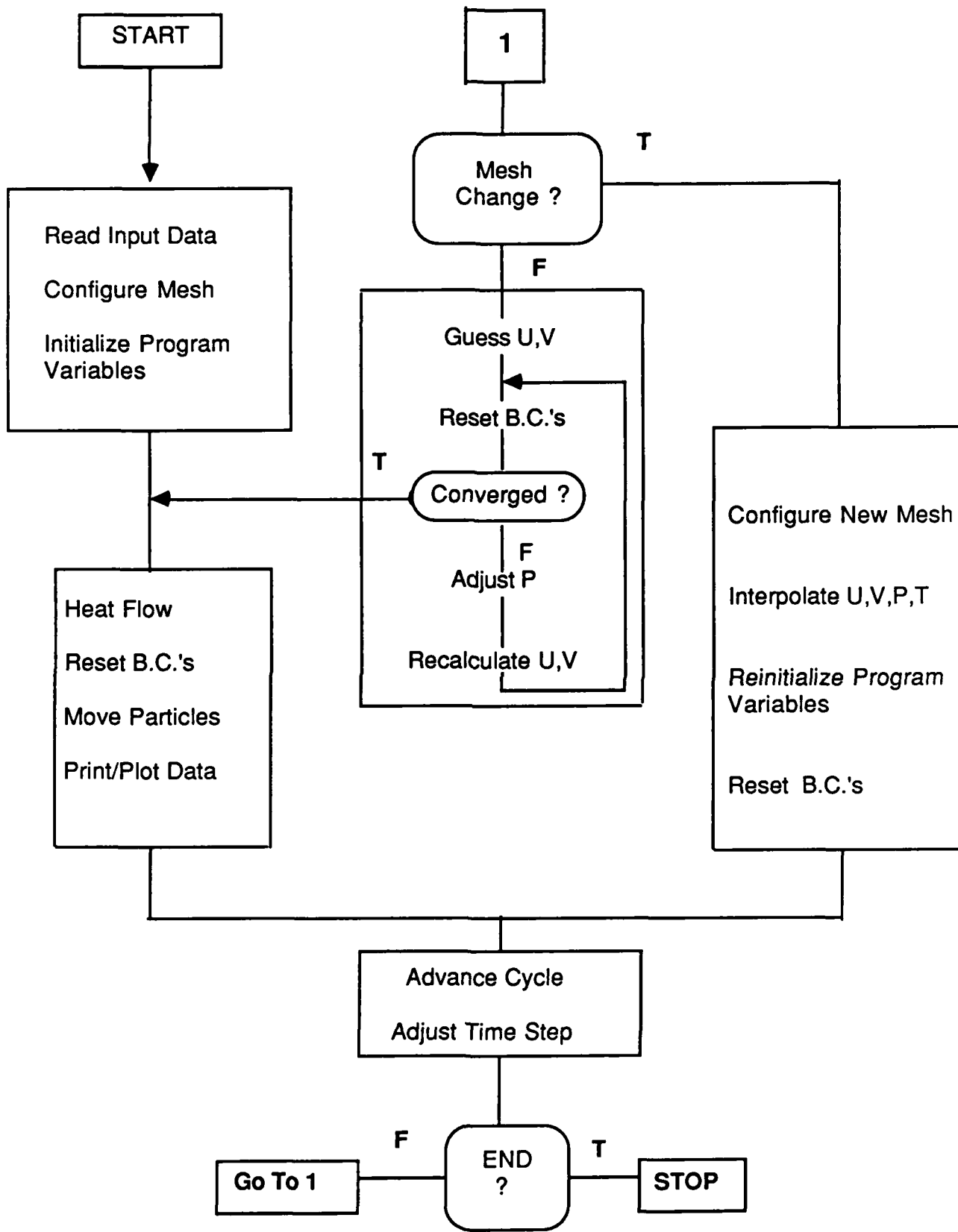

FLOW SHEET FOR S.P.L.A.S.H. MODEL

Hecker and H. Casey for making available super computer time for Drexel. The next stage is to perform a parametric study by varying the controlling parameters of the model to ascertain their combined effects and trends which develop. This will be followed up by a laboratory scale parametric study using various oils, organic liquids and low melting range alloys. The progression of the droplets splatting through time will be recorded using high speed photography; thus providing continuous comparison with the predicted results of the model. Full scale testing of the model will follow this; microscopically examining the in-situ sprayed deposit to verify that the effects of scale are properly handled by the model.

4. EXPERIMENTAL RESULTS AND DISCUSSION

Experiments were carried out to characterize and study the droplets in flight and during consolidation at the substrate. The influence of spray deposition process parameters on the resultant microstructure were investigated.

4.1 Droplet Velocity

Droplet velocities have been estimated by still photography using a Nikon FA camera equipped with a macro lens and a motordrive (4 frames per second). Individual droplets produced streaks on 35 mm film which was exposed for 1/4000 second (Figure 11). Droplet velocities were measured from the length of these streaks, and were found to be approximately 120 m/s prior to impact upon the substrate.

4.2 Droplet Solidification : Glass Slide Experiments

Glass slide experiments were carried out to experimentally determine the extent of solidification of droplets along their flight distance. Individual droplets were intercepted on glass slides at flight distances of 200, 300, 350 and 400mm from the point of atomization (Figure 12). Typically, a range of droplet sizes is observed. Small droplets are solidified, they are nearly spherical in shape and have smooth surfaces (Figure 13). Some of the larger droplets are partially solidified when they are intercepted on the glass slides and fragment along the interdendritic regions but retain their general shape (Figure 14). Liquid droplets spread out radially and are found as splats (Figure 15). For Ni - 20 wt. %Cr, d^* is found to vary from 55 μ m at 200mm, to 75 μ m at 300mm. Table 1 compares the experimental results with the computer predictions for the two extremes of undercooling (see section 3.2 and Figures 5 & 7). The experimental results seem to confirm that homogeneous nucleation is occurring.

4.3 Preform Deposits

A variety of Fe, Ni, Cu and Pb alloy systems have been spray deposited. Table 2 is a complete list of the alloys which are being investigated. These systems were selected to study the influence of alloy composition and freezing range on the resultant microstructures. M2 tool steel and the Ni-Cr system have been studied the most and will be presented in this report.

Normally, a melt of 30 lbs. was spray deposited in 40 seconds forming a solid disc preform of 5" diameter and 4" thick. The preform yield was 70-80% of the original charge and the other 20-30% was collected as overspray powder. The overspray powder is smooth and spherical (Figure 16). Typically, the powders have a mean diameter of approx. 80 μm and a standard deviation of 1.75.

The microstructure of an M2 disc preform is shown in Figure 17. At the bottom of the preform nearest to the substrate is a very refined martensitic structure with fine-scale M_6C eutectic carbides. This is due to the quenching effect as the first few droplets impinge upon the cold substrate. Within the first few millimetres the microstructure coarsens considerably. Thereafter the microstructure exhibits a slight degree of coarsening but remains quite uniform over the rest of the deposit thickness. Most of the quenching is carried out by the atomizing gas and after the initial few droplets are deposited very little heat extraction occurs through the substrate. Indeed a thick preform cools relatively slowly on the substrate. For this reason the M_6C eutectic carbides are quite coarse near the top of the preform. In the simple binary Ni-Cr system considerable solid state coarsening occurred after deposition. This was most evident in the preform microstructure of pure Ni and Ni-20wt.%Cr which exhibited grains larger than 50 μm whereas the overspray powders exhibited fine grains of the order of 5 to 10 μm .

4.4 Spray Deposition Process Parameters

The influence of the spray deposition process parameters on atomization and consolidation are summarized in Table 3. Increasing the melt superheat decreases the melt viscosity allowing the atomizing gas to break-up the metal stream into a finer distribution of liquid droplets. Therefore the mean droplet diameter d_m decreases. However this viscosity effect is not as significant as the intrinsic superheat of the droplets which must be removed before the onset of solidification. In general, increasing melt superheat beyond optimum levels produces a "hot" spray and the resulting deposit microstructure resembles a conventional casting.

Increasing the gas pressure increases the energy available for atomization and therefore breaks-up the metal stream into a finer dispersion of droplets. In addition, an increased gas pressure results in a higher cooling rate of the droplets. A critical balance is required between overquenching and underquenching. If the gas pressure is too low, the spray of droplets will retain the superheat and the deposit will be too hot with a degree of porosity. If the gas pressure is too high, the droplets will be fully solid prior to impact

and a large number of pre-solidified droplets with prior particle boundaries will be visible in the preform.

With increasing flight distance an increasing number of droplets are solidifying and the resultant deposit is cooler. The degree of melt superheat, metal flow rate and atomizing gas pressure are factors which will determine the ideal flight distance for a trial run.

4.5 Microstructural Refinement via Spray Deposition

Figure 18 is a schematic of the spray deposition process. The spray comprises of a range of droplet sizes. Smaller droplets will be fully solid; intermediate sizes will be partially solid and larger droplets will be fully liquid. Due to the high cooling rates involved in the atomization process ($>10^6$ K/s) the microstructure of the solidified and partially solidified droplets will be extremely refined - in the form of fine grains or dendrites, depending on the alloy system used. The high deposition rates present in spray deposition are thought to give rise to a very thin liquid layer on the surface of the preform deposit. When a solid or partially solid droplet impacts upon the deposit surface, it can break-up along granular or dendritic boundaries forming large numbers of small nuclei within the thin liquid layer. The relatively high cooling rate of this thin liquid layer, along with the presence of the fine nuclei is thought to be the source of microstructural refinement in the final deposit.

The final preform which can be several inches thick cools slowly after the initial deposition process. However this will not affect the final microstructure if precipitates can pin the grain boundaries. Instead, the slower cooling of a thick preform is analogous to annealing and it may be possible that spray deposited alloys are more readily forgeable than their conventionally cast equivalents.

5. CONCLUSIONS

1. A mathematical model of the spray deposition process has been developed to calculate the velocity and temperature profiles of droplets prior to impacting upon the substrate. Droplet velocities have been estimated by a photographic technique and found to be approximately 120 m/s near the substrate.
2. The model accounts for the undercooling and solidification of the droplets. To study the extent of solidification, individual droplets have been arrested by glass slides positioned at various flight distances in the spray. There is close agreement between the extent of solidification predicted by homogeneous nucleation and that found in the glass slide experiments.
3. Another computer model predicting the splatting behavior of individual droplets is in the final stages of development. Preliminary results are encouraging.
4. The martensitic microstructure of M2 tool steel was highly refined near the substrate but coarsened within a few millimeters. Thereafter the microstructure remains quite uniform.
5. In the Ni-Cr system solid state coarsening occurred in thick preforms. The overspray powders retained a rapidly solidified microstructure.
6. The influential process parameters are melt superheat, metal flow rate, atomization gas pressure and flight distance. A critical balance between these parameters is essential to achieve the required microstructure and density in the final deposit.
7. Increasing melt superheat and metal flow rate above optimum conditions produces a "hot" spray and the resulting deposit microstructure resembles a conventional ingot casting.
8. Increasing the atomization gas pressure and flight distance above optimum conditions produces a "cold" spray and results in a large number of pre-solidified droplets in the deposit.
9. Microstructural refinement via spray deposition is thought to occur due to the break-up of solid and partially solid droplets upon impact. The fragments act as grain refining nuclei for the resultant microstructure.

FUTURE PLANS

Computer models will continue to be used to predict the behavior of the droplets in flight and after impacting upon the substrate.

Experiments will be designed to verify the predictions of the computer models. These will involve heat flow measurements in the deposit and the substrate. High speed video will be used to study the splatting of liquid droplets.

To further determine the influential spray deposition process parameters, one alloy system, possibly M2 tool steel, will be sprayed over a wide range of process conditions.

REFERENCES

1. Osprey Metals Ltd., U.K. Patent # 147239.
2. A.G. Leatham, R.G. Brooks and M. Yaman : in "Modern Developments in Powder Metallurgy", MPIF Press, 1985, Vol.15 -17, p. 157.
3. Office of Naval Research: Technical Report No.1, Contract N 00014-84-K-0472; NR 650-025.
4. Kurten et al : in "Bubbles, Drops and Particles", 1978, Acad. Press.
5. W.E. Ranz and W.R. Marshall : Chem. Eng. Prog., 1952, 48, p.173.
6. I. Kimura and A. Kanzawa : AIAA Journal 1965, p. 476.
7. B.D. Nichols, C.W. Hirt and R.S. Hotchkiss : "SOLA-VOF": A Solution Algorithm for Transient Fluid Flow with Multiple Free Boundaries", N.E.S.C. Report No. 948, National Energy Software Center, Argonne National Labs., Argonne, Illinois.

APPENDIX 1

DREXEL'S SPRAY DEPOSITION EQUIPMENT

The major components of Drexel's spray deposition equipment can be described in terms of (i) the melting system, (ii) the gas atomization operation and (iii) the configuration and movement of the substrate. Figure 1 is a schematic of the spray deposition process.

(i) Melting System

The material to be spray deposited is placed in an alumina crucible which can hold up to 30 kg of metal. A surrounding protective cage keeps the crucible wall under compression and arrests the flow of molten metal in the event of a break-out. The protective cage consists of a sand-based ramming mix confined within a thin-walled cylinder of stainless steel. The protective cage, crucible and charge are placed inside an induction coil box which sits on the atomizing block at the top of the spray chamber. An Inductotherm 180 kW induction generator supplies power to the coil box.

During melting the chamber is purged with nitrogen gas and a slight overpressure of nitrogen gas is fed into the sealed crucible to prevent the material from oxidizing. The melting system is designed so that metal at the bottom of the crucible is the last to melt. When this melts all of the molten metal pours through a refractory nozzle in the bottom of the crucible. A stream of molten metal, the diameter of which is the same as the diameter of the the nozzle, then pours into the atomizing zone.

(ii) Gas Atomization Process

In the atomizing region the molten metal stream is broken-up into a spray of small droplets by a high pressure of nitrogen gas. An Airco storage vessel, which can hold up to 70 inches water gage pressure of liquid nitrogen, supplies the atomizing gas. The flow of nitrogen into the atomizer block is regulated by a gas control panel specially designed for Drexel's plant. Typically, the atomizing gas pressure is 100-150 psi. The flow rate of molten metal into the atomizing region is determined by the diameter of the stream from the nozzle and the head of metal in the crucible. An overpressure of gas to the top of the crucible compensates for the falling head of metal.

(iii) Substrate Configuration and Movement

The substrate can be made of either metal or a refractory material. In general, the molten droplets will adhere better to a heated metallic substrate than to a water-cooled metallic substrate. Depending on the shape and movement of the substrate a number of shapes can be fabricated. By rotating a disc underneath the spray a solid cylinder can be produced. By rotating a mandrel in the spray a coating can be applied, or a thin or thick walled tube can be manufactured. Flat substrates can be used to produce strip and sheet.

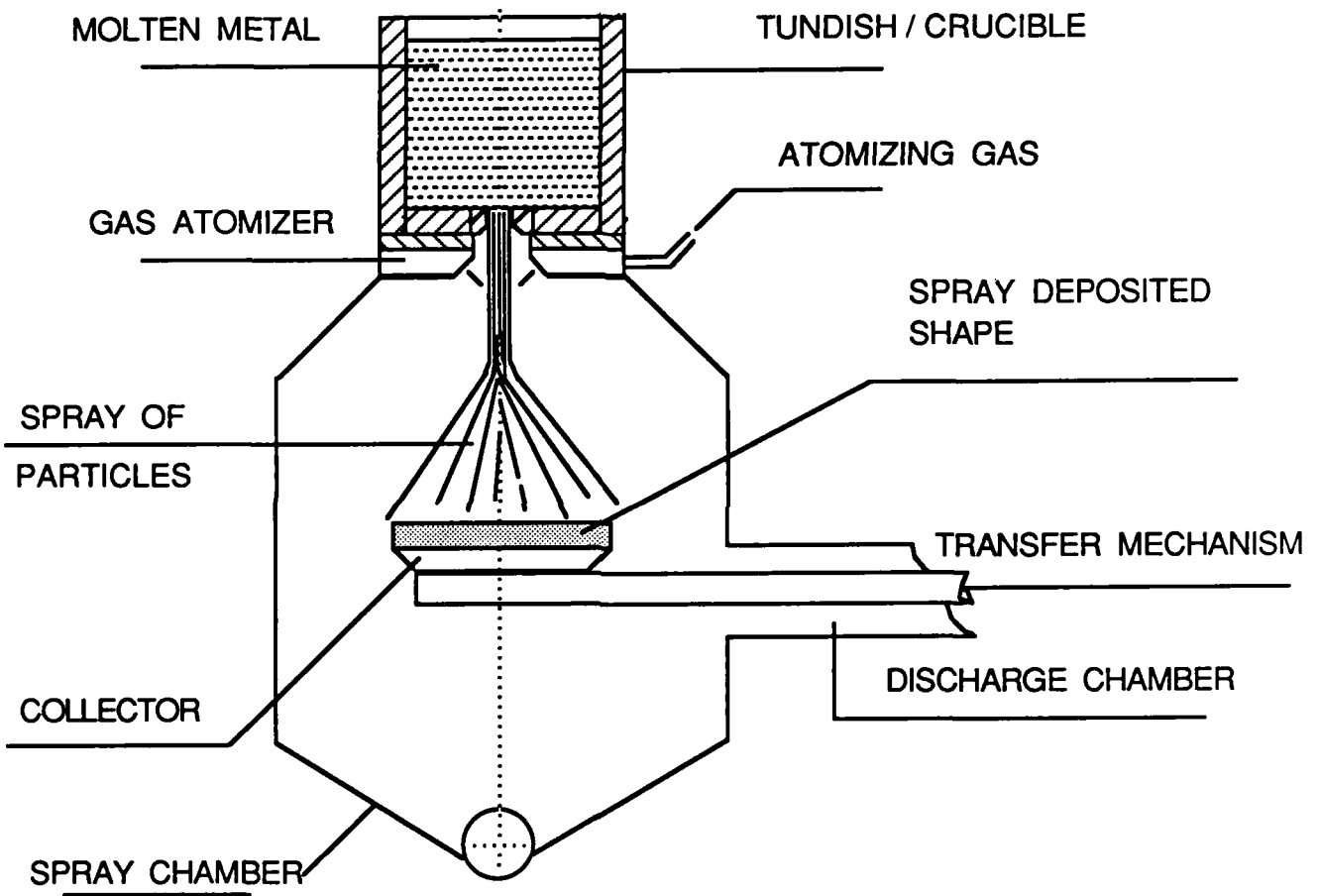

Figure 1 : Schematic of spray deposition process

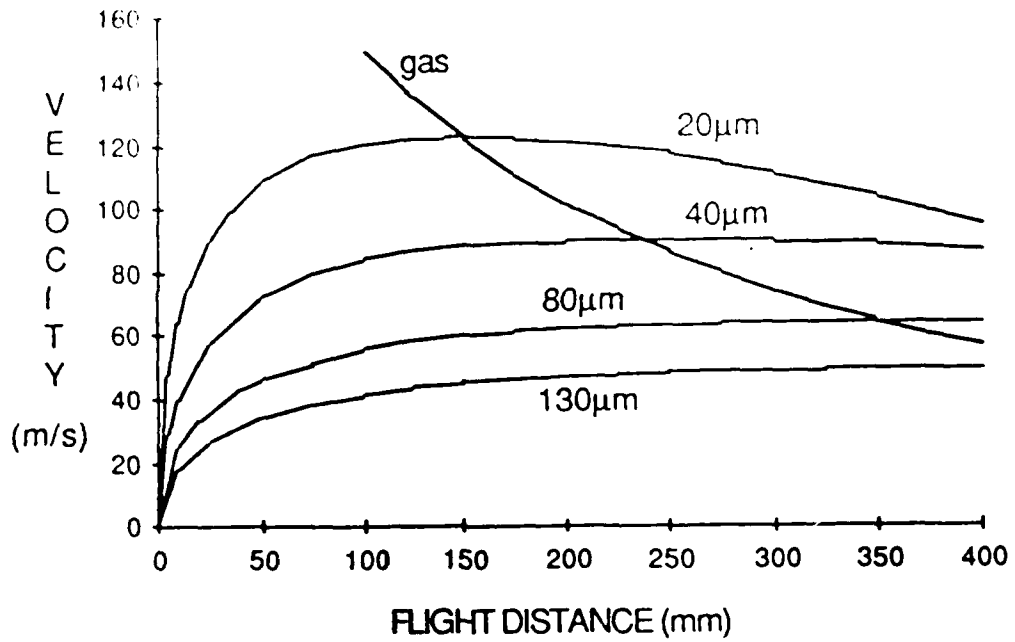

Figure 2. Predicted Velocity Profiles for Ni-20%Cr droplets

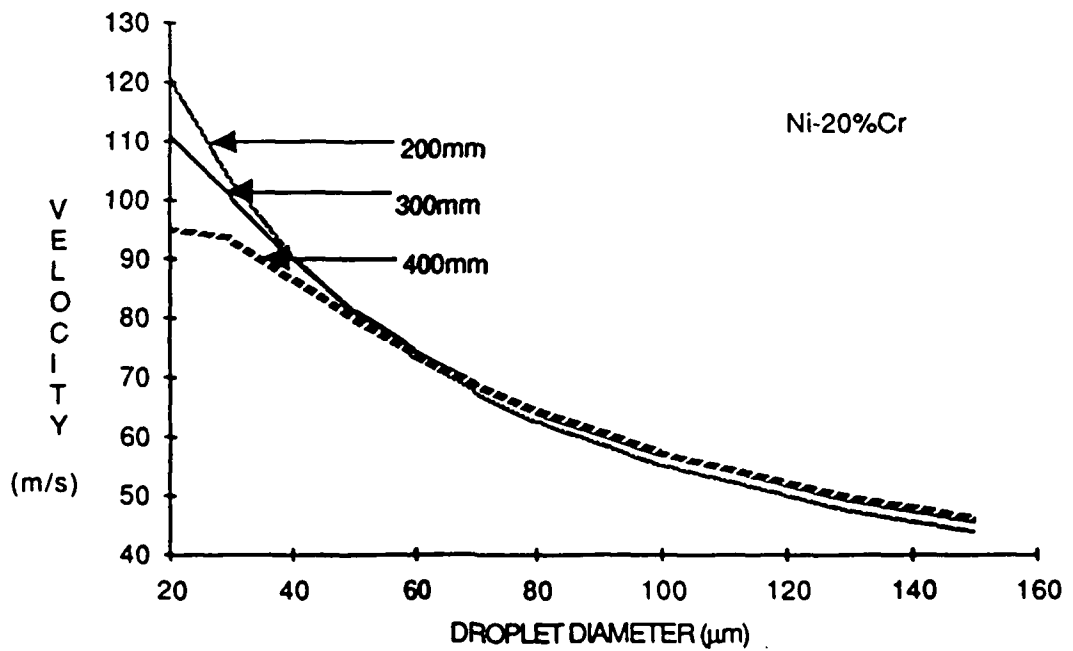

Figure 3. Predicted droplet velocity against diameter at three flight distances

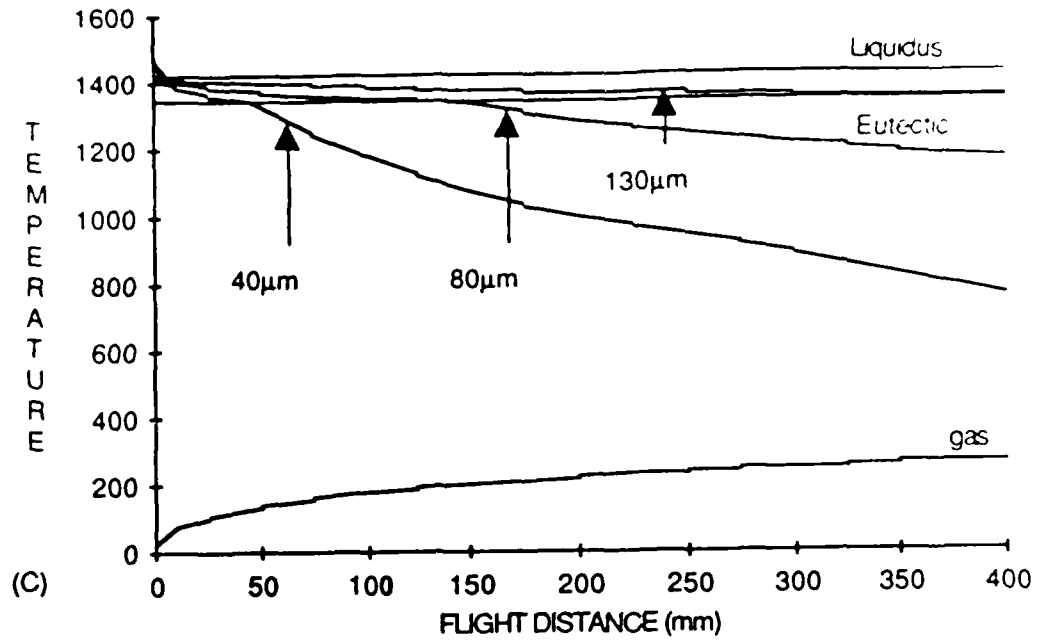

Figure 4. Predicted temperature profiles of Ni-20%Cr droplets with no undercooling

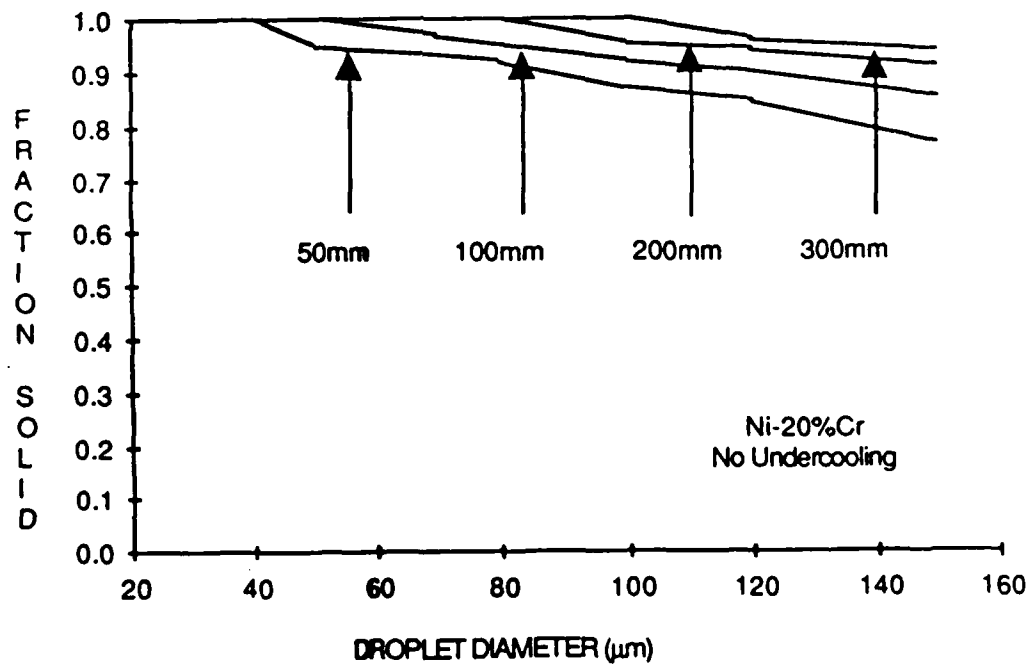

Figure 5. Fraction solidified as a function of droplet diameter at four flight distances

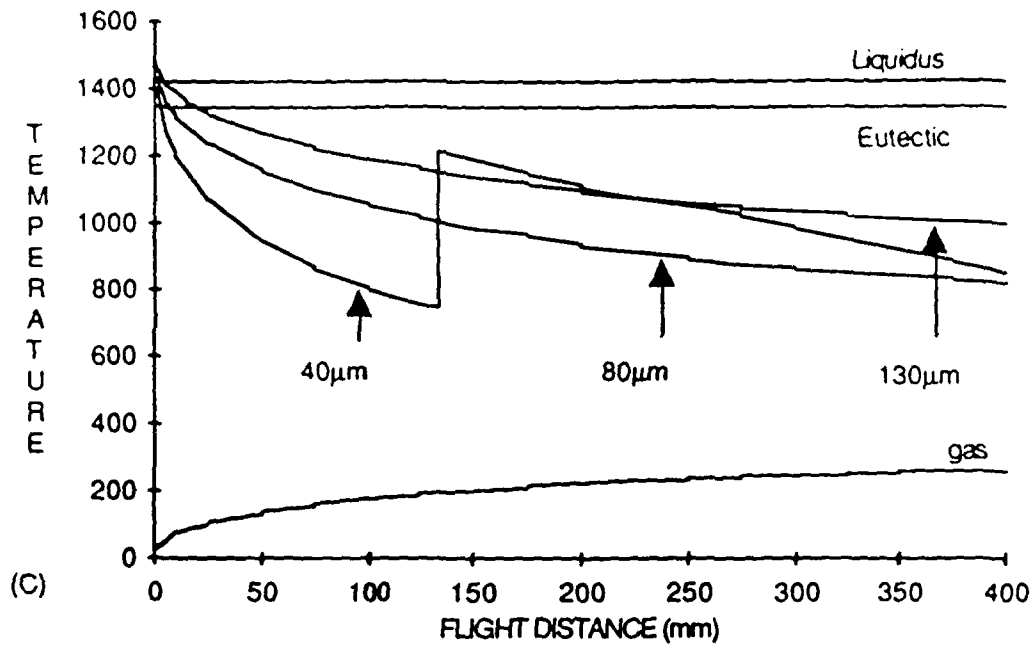

Figure 6. Temperature profiles of Ni-20%Cr droplets assuming homogeneous nucleation

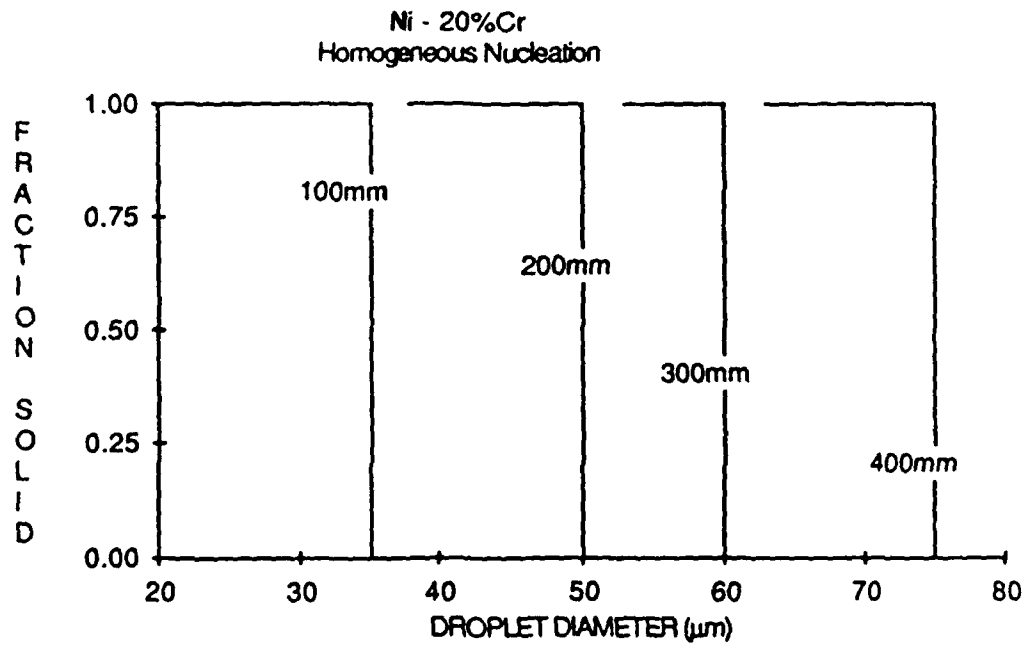

Figure 7. Fraction solidified as a function of droplet diameter at four flight distances

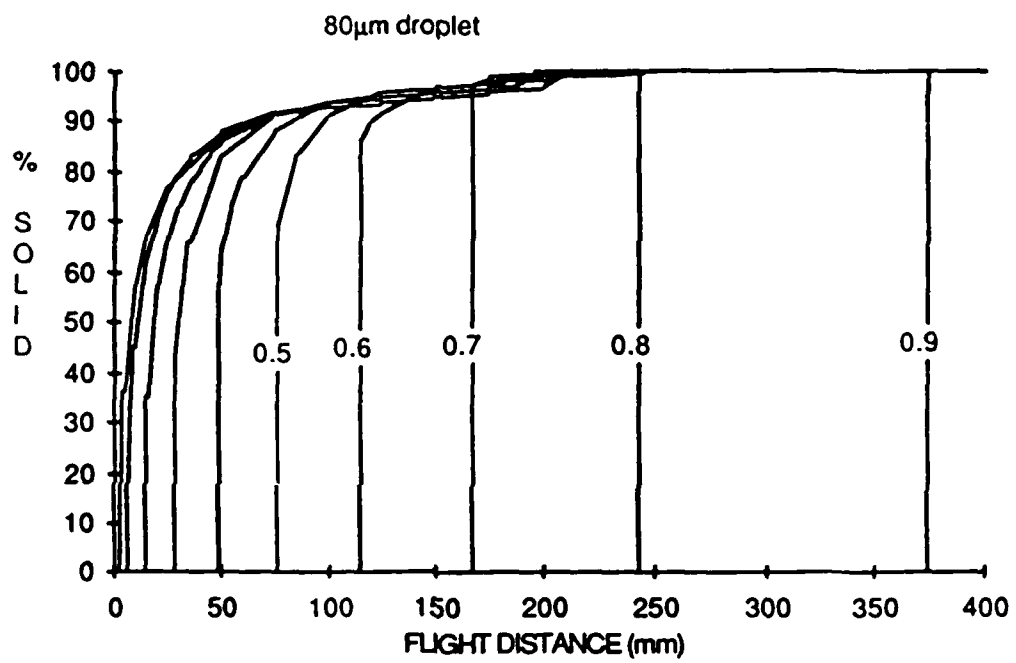

Figure 8. Solidification behavior of NI-20%Cr droplet for ' f ' values in the range 0-1

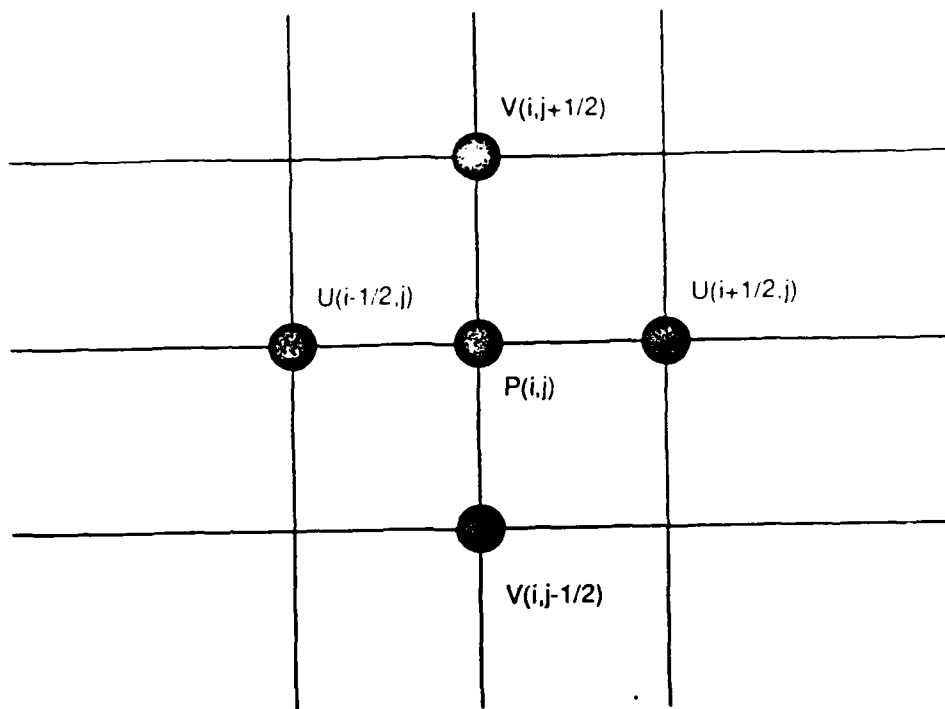

Figure 9. Eulerian Mesh showing the locations of the primitive variables.
 U and V represent the tangential and normal components of velocity.
 P represents pressure of cell i, j

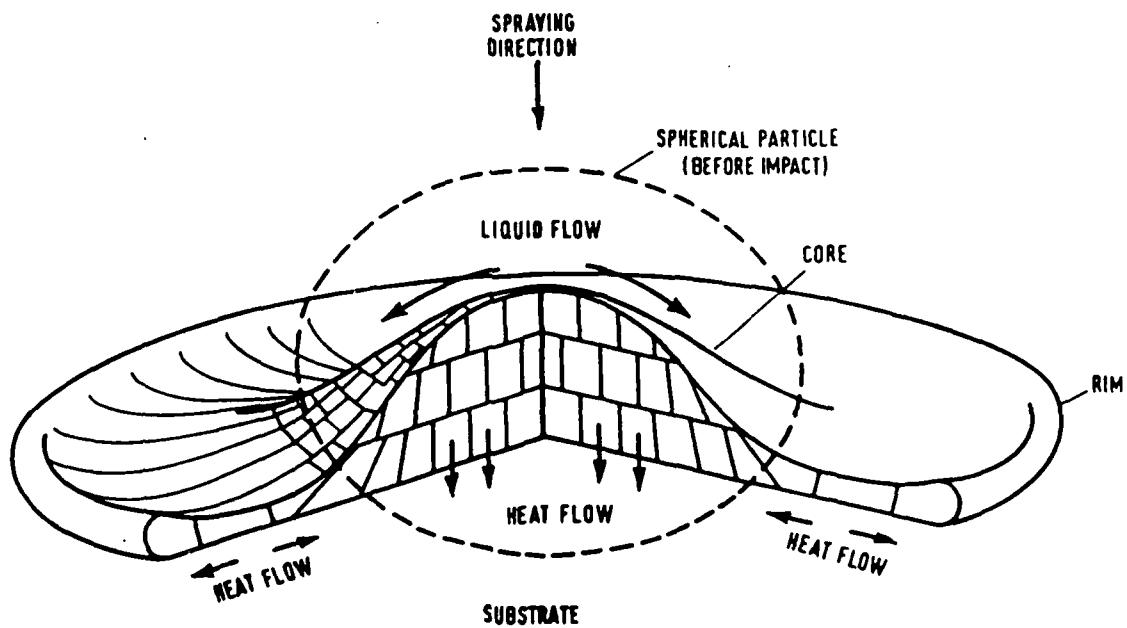

Figure 10. Droplet after impinging on flat substrate



Figure 11. Droplets in flight recorded on 35mm film exposed for 1/4000 sec.
Droplet velocities have been estimated to be ~120m/s prior to impact.

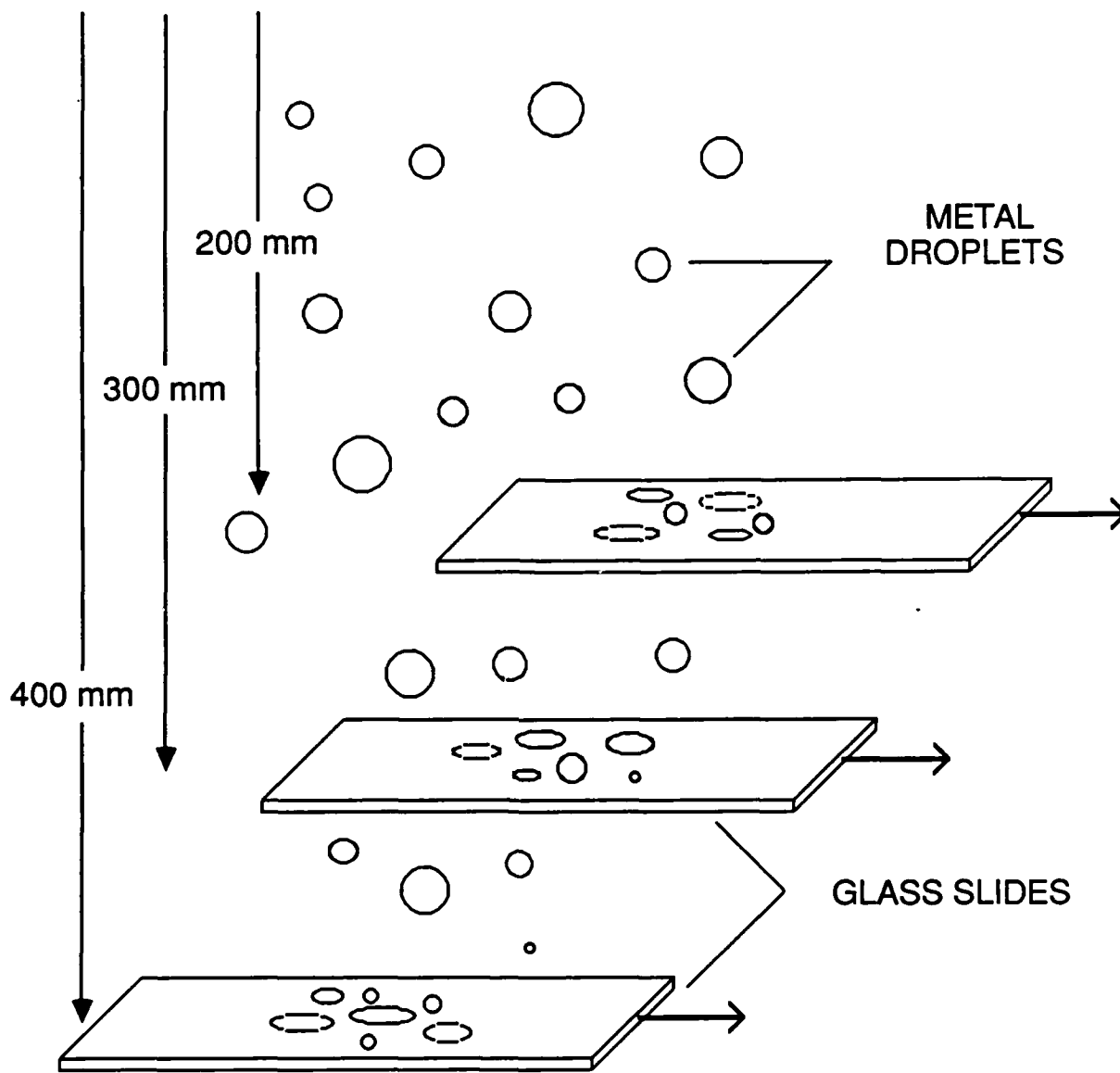

Figure 12. Schematic diagram of glass slide experiments

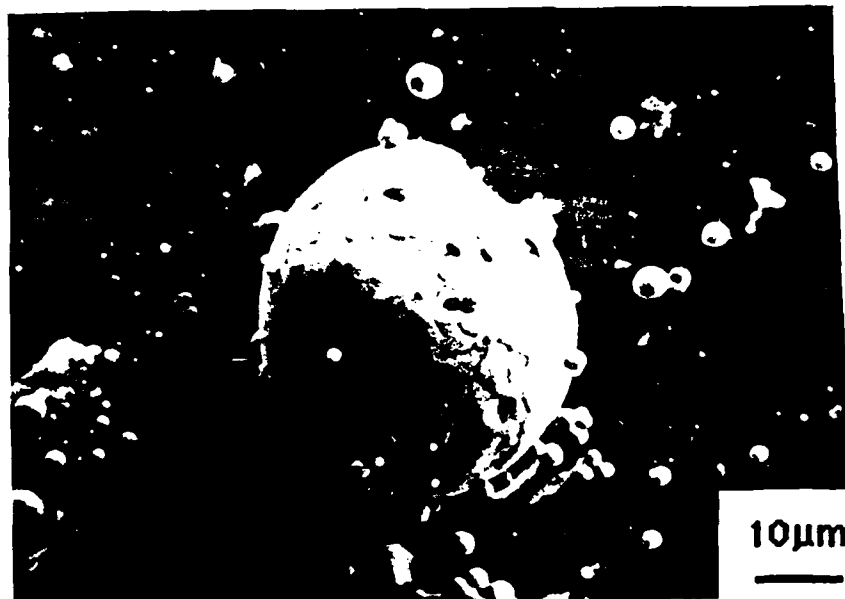

Figure 13. Ni-Cr droplet intercepted on glass slide. Fully solidified.



Figure 14. Partially solidified Ni-Cr droplet.

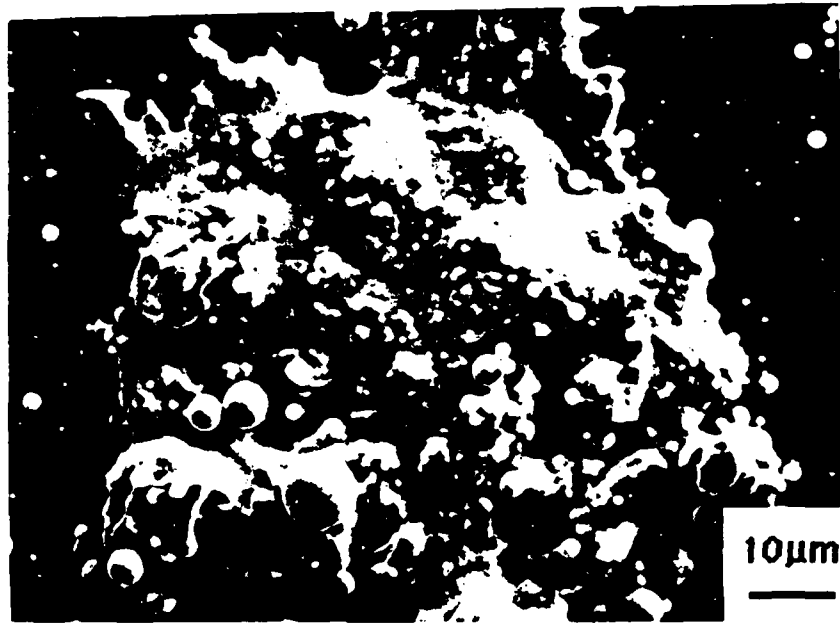

Figure 15. Fully liquid Ni-Cr splat.

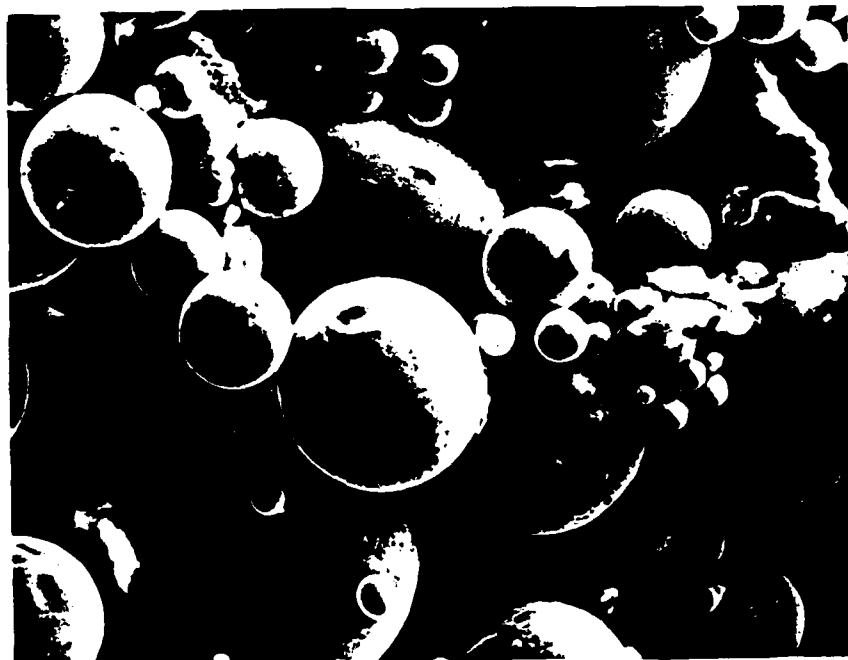

Figure 16. M2 tool steel overspray powder.

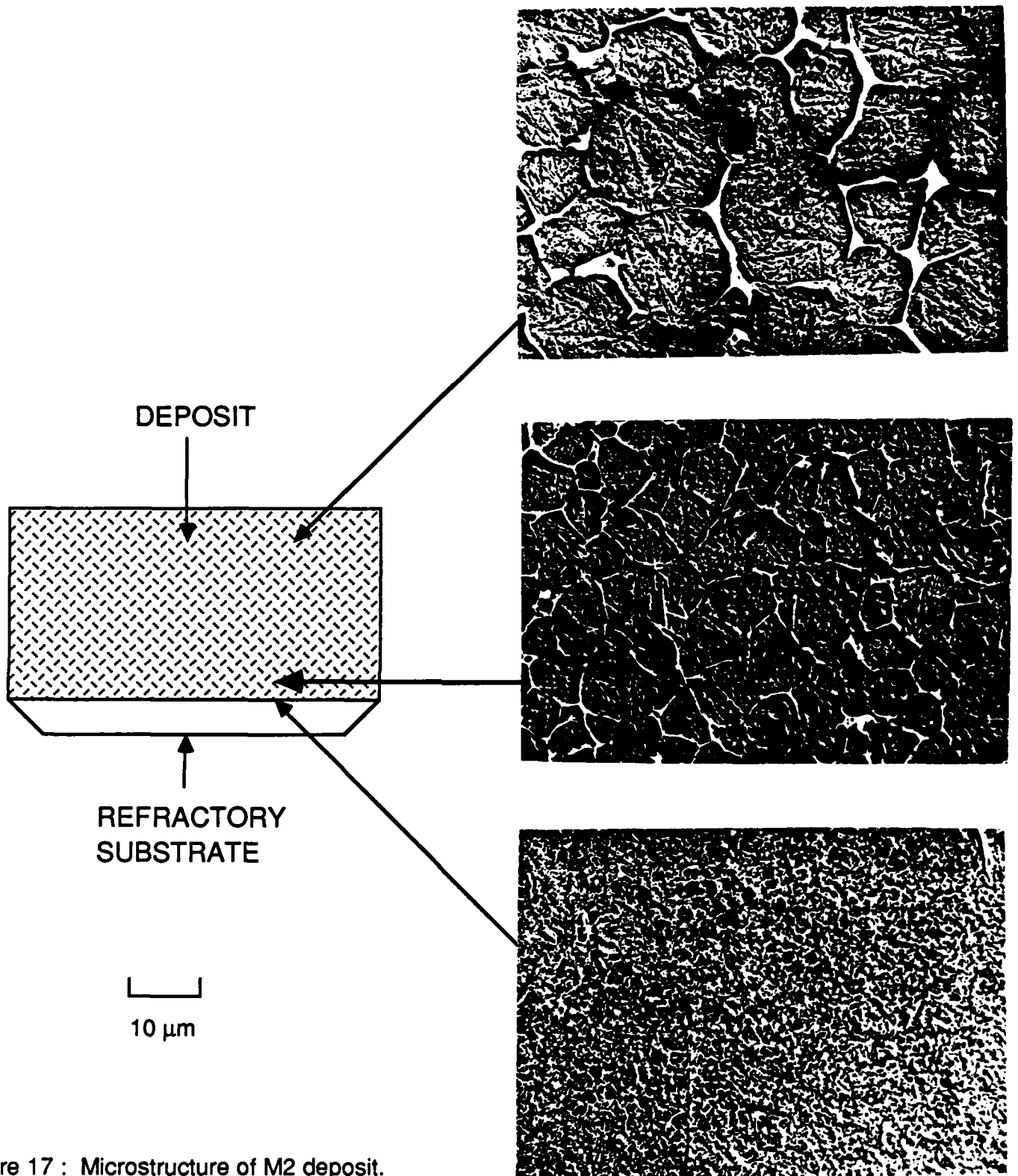

Figure 17 : Microstructure of M2 deposit.

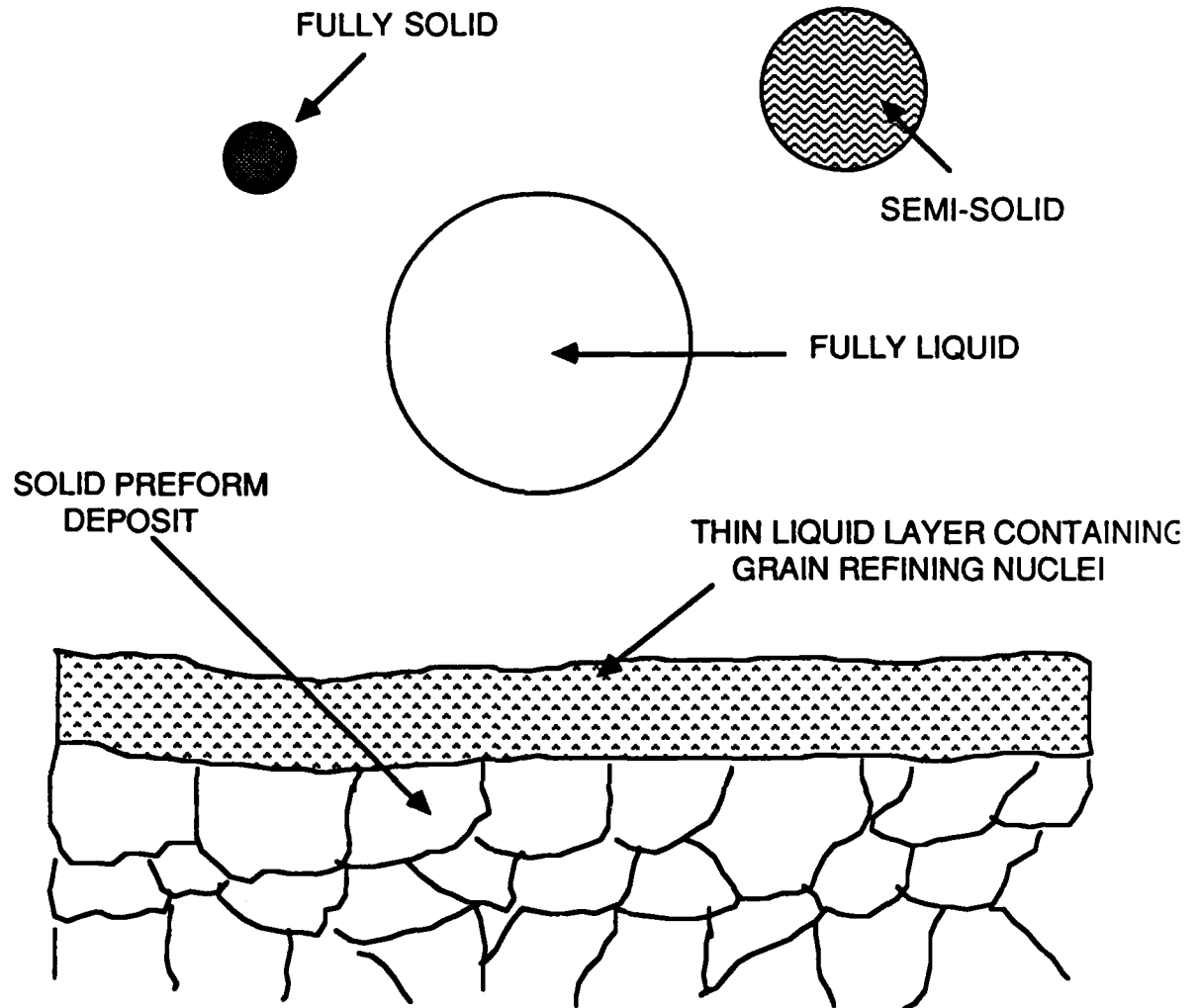

FIGURE 18 : Microstructural refinement via spray deposition

TABLE 1

Comparison of Theoretical and Experimental Values for d^*
at flight distances of 200 and 300mm.

	d^* at 200 mm	d^* at 300 mm
No undercooling = heterogeneous nucleation	80	100
Large undercooling = homogeneous nucleation	50	60
Experimental (glass slides)	55	75

N.B. d^* (microns) is the size of the largest solidified droplet at a given flight distance.

TABLE 2

LIST OF ALLOY COMPOSITIONS WHICH ARE BEING INVESTIGATED

ALLOY SYSTEM	RESEARCH INTEREST
M2 tool steel	microstructure is known to be sensitive to changes in spray deposition conditions
pure Ni	melting pt. = 1455 °C
Ni - 20wt.%Cr	freezing range = 20 °C
Ni - 51wt.%Cr	eutectic composition
Ni - 65wt.%Cr	freezing range = 200 °C
Fe - 20wt.%Mn	T(L) = 1450 °C freezing range = 20 °C
Fe - 20wt.%Cu	T(L) = 1450 °C freezing range = 350 °C
Pb - 10wt.%Sn	Pb - Sn is a low temperature system which has been extensively studied. eutectic composition
Pb - 40wt.%Sn	
Pb - 62wt.%Sn	
Pb - 90wt.%Sn	

TABLE 3**EFFECT OF PROCESS PARAMETERS ON DROPLET
AND PREFORM CHARACTERISTICS**

Process Parameter	Droplet Diameter	Fraction of Liquid Droplets	Porosity Levels
Melt Superheat (50 - 200°C) ↑	d_m ↓	% liq. ↑	porosity ↑
Atomizing Gas Pressure (50 - 120 psi) ↑	d_m ↓	● % liq. ↓	porosity ↓
Flight Distance 10" - 16" 250 - 400mm ↑	NSE	● % liq. ↓	porosity ↓
Substrate (Cu/alumina) (stationary/ moving)	NSE	NSE	NSE

NSE : No significant effect

● : Significant effect

END

12-86

DTIC