

AD-A173 875

FLIGHT SIMULATION(U) ADVISORY GROUP FOR AEROSPACE
RESEARCH AND DEVELOPMENT NEUILLY-SUR-SEINE (FRANCE)
A M COOK ET AL. SEP 86 AGARD-CP-408

1/4

UNCLASSIFIED

F/G 5/9

NL

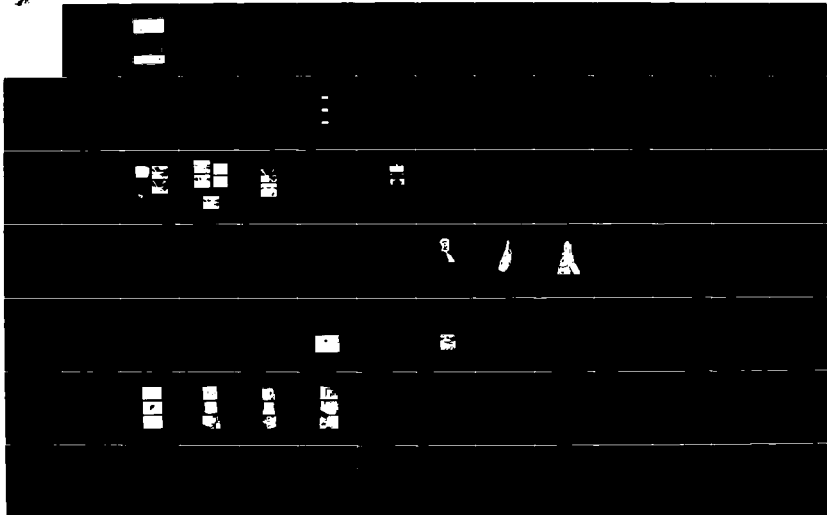

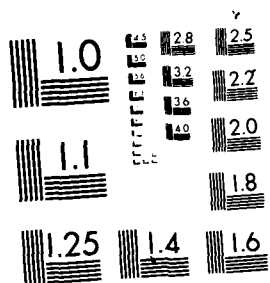

MICROCOPY RESOLUTION TEST CHART
 NATIONAL BUREAU OF STANDARDS-1963-A

AD-A173 875

2

AGARD-CP-408

AGARD-CP-408

AGARD

ADVISORY GROUP FOR AEROSPACE RESEARCH & DEVELOPMENT

7 RUE ANCELLE 92200 NEUILLY SUR SEINE FRANCE

AGARD CONFERENCE PROCEEDINGS No.408

Flight Simulation

DTIC
ELECTE
NOV 05 1988
S D

THIS FILE COPY

NORTH ATLANTIC TREATY ORGANIZATION



DISTRIBUTION AND AVAILABILITY
ON BACK COVER

THE MISSION OF AGARD

The mission of AGARD is to bring together the leading personalities of the NATO nations in the fields of science and technology relating to aerospace for the following purposes:

- Exchanging of scientific and technical information;
- Continuously stimulating advances in the aerospace sciences relevant to strengthening the common defence posture;
- Improving the co-operation among member nations in aerospace research and development;
- Providing scientific and technical advice and assistance to the Military Committee in the field of aerospace research and development (with particular regard to its military application);
- Rendering scientific and technical assistance, as requested, to other NATO bodies and to member nations in connection with research and development problems in the aerospace field;
- Providing assistance to member nations for the purpose of increasing their scientific and technical potential;
- Recommending effective ways for the member nations to use their research and development capabilities for the common benefit of the NATO community.

The highest authority within AGARD is the National Delegates Board consisting of officially appointed senior representatives from each member nation. The mission of AGARD is carried out through the Panels which are composed of experts appointed by the National Delegates, the Consultant and Exchange Programme and the Aerospace Applications Studies Programme. The results of AGARD work are reported to the member nations and the NATO Authorities through the AGARD series of publications of which this is one.

Participation in AGARD activities is by invitation only and is normally limited to citizens of the NATO nations.

The content of this publication has been reproduced directly from material supplied by AGARD or the authors.

Published September 1986

Copyright © AGARD 1986
All Rights Reserved

ISBN 92-835-0394-5



Printed by Specialised Printing Services Limited
40 Chigwell Lane, Loughton, Essex IG10 3TZ.

AGARD-CP-408

NORTH ATLANTIC TREATY ORGANIZATION
ADVISORY GROUP FOR AEROSPACE RESEARCH AND DEVELOPMENT
(ORGANISATION DU TRAITE DE L'ATLANTIQUE NORD)

AGARD Conference Proceedings No.408

FLIGHT SIMULATION

Papers presented at the Flight Mechanics Panel symposium held in
Cambridge, United Kingdom, 30 September to 3 October 1985.

ABSTRACT

In recent years important advances have been made in technology for both ground-based and in-flight simulators. There has equally been a broadening of the use of flight simulators for research, development and training purposes. The objectives of this AGARD Flight Mechanics Panel symposium were to provide an up-to-date description of the state-of-the-art of technology and engineering for both ground-based and in-flight simulators and to place into context their respective roles within the aerospace scene. All papers were obtained by invitation.

These Conference Proceedings commissioned by the AGARD Flight Mechanics Panel contain a Technical Evaluation Report which is also available separately as an Executive Summary as AGARD-AR-234.

Dans les dernières années, de grands progrès ont été réalisés dans la technologie des simulateurs installés au sol et à bord des avions. Egalement une large utilisation des simulateurs de vol a été faite pour la recherche, le développement et l'entraînement. Les objectifs du symposium de la commission mécanique de vol de l'AGARD étaient de fournir une description actualisée de l'état de la technologie et de l'ingénierie des simulateurs installés au sol ou à bord des avions et de les placer dans le contexte de leurs rôles respectifs du domaine aérospatial. Toutes les communications ont été obtenues par voie d'invitation.

Le compte rendu du symposium demandé par la commission Mécanique du Vol de l'AGARD contient un rapport d'évaluation technique qui est aussi disponible de façon séparée sous forme d'un résumé intitulé "Executive Summary, AGARD AR-234".

Accession For	
NTIS CRA&I	<input checked="" type="checkbox"/>
DTIC TAB	<input type="checkbox"/>
Unannounced	<input type="checkbox"/>
Justification	
By	
Distribution /	
Availability Codes	
Dist	Avail and/or Special
A-1	



FLIGHT MECHANICS PANEL OFFICERS

Chairman: Dr Ing. P.Hamel
Director, Institut für Flugmechanik
DFVLR
Postfach 3267
D-3300 Braunschweig
Federal Republic of Germany

Deputy Chairman: Dr Ing. A.Filisetti
Engineering Assistant Director
Combat Aircraft Group
AERITALIA
Corso Marche 41
10146 Torino
Italy

TECHNICAL PROGRAMME COMMITTEE

Mr R.C.A.Harrach
Associate Director of Vehicle Technology Code 60C
Naval Air Development Center
Warminster, PA 18974
USA

Dr H.A.Mooij
Head, Flight Division
National Aerospace Laboratory (NLR)
P.O. Box 90502
1006 BM Amsterdam
The Netherlands

HOST NATION COORDINATOR

Mr A.A.Woodfield
Superintendent FS(B)3 Division
Royal Aircraft Establishment
Bedford, MK41 6AE
United Kingdom

PANEL EXECUTIVE

Mr H.A.Torode
AGARD/OTAN
7 rue Ancelle
92200 Neuilly-sur-Seine
France

ACKNOWLEDGEMENT

The Flight Mechanics Panel wishes to express its thanks to the United Kingdom National Delegates for the invitation to hold this meeting in Cambridge, England, and for the facilities and personnel which made this meeting possible.

CONTENTS

	Page
ABSTRACT	iii
PANEL OFFICERS	iv
TECHNICAL EVALUATION REPORT by A.Cook	vii
	Reference
KEYNOTE ADDRESS MANNED FLIGHT SIMULATION – CHALLENGE AND RESPONSE by J.C.Dusterberry	K
VISUAL AND MOTION CUEING IN HELICOPTER SIMULATION by R.S.Bray	1
VISUAL DISPLAY RESEARCH TOOL by P.M.Murray and B.Barber	2
ADVANCED VISUALS IN MISSION SIMULATORS by D.A.Cowdrey	3
THE APPLICATION OF OPTIMAL CONTROL TECHNIQUES TO THE UTIAS RESEARCH SIMULATOR by L.D.Reid	4
OASIS – UN OUTIL MODERNE POUR LA SIMULATION TEMPS REEL OASIS – A MODERN TOOL FOR REAL-TIME SIMULATION par J.Benoit	5
SIMULATOR MOTION CHARACTERISTICS AND PERCEPTUAL FIDELITY by B.N.Tomlinson	6A
SIMULATION OF AIRCRAFT BEHAVIOUR ON AND CLOSE TO THE GROUND – SUMMARY OF AGARDOGRAPH AG-285 by A.G.Barnes	6B
USE OF VDU's BY FLIGHT SIMULATOR INSTRUCTORS by M.A.Brunt	7
PROGRESS IN THE IMPLEMENTATION OF AGARD-AR-144 IN MOTION SYSTEM ASSESSMENT AND MONITORING by K.J.Staples, W.Love and D.Parkinson	8
FLEXIBLE AND HIGH QUALITY SOFTWARE ON A MULTI PROCESSOR COMPUTER SYSTEM CONTROLLING A RESEARCH FLIGHT SIMULATOR by A.P.L.A.Marsman	9
COMPUTER SIMULATION STUDIES ON HUMAN CONTROL RELIABILITY IN MANUAL AIRCRAFT CONTROL: THE ORIGIN OF PIO by K.Brauser and R.Seifert	10
TRENDS IN GROUND-BASED AND IN-FLIGHT SIMULATORS FOR DEVELOPMENT APPLICATIONS by P.E.Blatt and D.R.Gum	11
PILOTED SIMULATION IN THE DEVELOPMENT OF THE XV-15 TILT ROTOR RESEARCH AIRCRAFT by R.L.Marr and G.B.Churchill	12
SIMULATION DES COMMANDES DE VOL ELECTRIQUES AU CENTRE D'ESSAIS EN VOL FRANÇAIS (CEV) POUR LES AVIONS DE TRANSPORT CIVIL par R.Vadrot	13

	Reference
MANNED AIR TO AIR COMBAT SIMULATION by P.A.Patzner	14
UTILIZATION OF SIMULATION TO SUPPORT F-14A LOW ALTITUDE HIGH ANGLE OF ATTACK FLIGHT TESTING by P.Conigliaro and R.Goodman	15
THE USE OF AERITALIA FLIGHT SIMULATOR FOR THE DEVELOPMENT OF THE AM-X WEAPON SYSTEM by A.Armando and M.Spinoni	16
RADAR SIMULATORS by J.C.Pietrement	17
THE DEVELOPMENT OF THE T-46 NEXT GENERATION TRAINER MANNED ENGINEERING SIMULATOR AT THE U.S. AIR FORCE FLIGHT TEST CENTER by J.C.Pick	18
OPERATIONAL TRAINING; APPLICATION AND EXPERIENCE by H.Friedrich	19
A METHOD FOR AIRCRAFT SIMULATION VERIFICATION AND VALIDATION DEVELOPED AT THE UNITED STATES AIR FORCE FLIGHT SIMULATION FACILITY by G.R.Anderson	20
CORRELATION BETWEEN FLIGHT SIMULATION AND PROCESSING OF FLIGHT TESTS BASED ON INERTIAL MEASUREMENTS by A.M.H.Nieuwpoort, J.H.Breeman, L.J.J.Erkelens and P.J.J.van der Geest	21
UNUSUAL AIRBORNE SIMULATOR APPLICATIONS by P.A.Reynolds	22
DFVLR IN-FLIGHT SIMULATORS ATTAS AND ATTHES FOR FLYING QUALITIES AND FLIGHT CONTROL RESEARCH by D.Hanke and G.Bouwer	23
DEVELOPMENT OF IN-FLIGHT SIMULATION AIRCRAFT FOR RESEARCH AND TRAINING APPLICATIONS IN UK by O.P.Nicholas, J.A.Giles and D.A.Williams	24
AIRBORNE SIMULATION AT THE NATIONAL AERONAUTICAL ESTABLISHMENT OF CANADA by J.M.Morgan	25
COLLECTED FLIGHT AND SIMULATION COMPARISONS AND CONSIDERATIONS by I.L.Ashkonas	26

TECHNICAL EVALUATION REPORT OF THE SYMPOSIUM ON "FLIGHT SIMULATION"

A. M. Cook, NASA-Ames Research Center

1. INTRODUCTION

This report evaluates the 67th Symposium of the AGARD Flight Mechanics Panel, held in Cambridge, United Kingdom, from 30 September to 3 October 1985. The subject was Flight Simulation.

It has been over seven years since the most previous AGARD meeting on this subject. That was the occasion of the Flight Mechanics Panel Specialists Meeting on "Piloted Aircraft Environment Simulation Techniques", held in Brussels, Belgium, from 24 to 27 April 1978. That conference resulted in the publication of AGARD-CP-249, and the Technical Evaluation Report, AGARD-AR-126, by K. J. Staples, both dated October 1978.

During the intervening period, important advances have been made in technology for both ground-based and in-flight simulators. In addition, there has been an equally important advance and broadening of the use of simulators for research, development, project and training purposes. The Flight Mechanics Panel has recently sponsored Working Groups on the characteristics of both motion and visual systems for ground-based flight simulators and also initiated publications on such topics as simulation validation, motion perceptual fidelity and simulation in close proximity to the ground. Most particularly, Panel Subcommittee 01 has reported in depth on the history, present status and future role of in-flight simulators.

In recognition of these important activities and of an emerging interest by nations which have not, to date, engaged in or made major investment in flight simulation, the Panel considered it to be most timely to hold a further symposium embracing both ground-based and in-flight simulation.

The objectives of the meeting were to:

- (1) Provide an up-to-date description of state-of-the-art technology and engineering for both ground-based and in-flight simulators, together with an indication of future possibilities;
- (2) Place the roles of ground-based simulators and in-flight simulators into context with one another and within the aerospace scene.

The conference was conducted at Churchill College, of Cambridge University. Attendance was slightly less than 200 persons, representing twelve of the NATO nations: Belgium, Canada, France, Federal Republic of Germany, Greece, Italy, Netherlands, Norway, Portugal, Turkey, United Kingdom and the United States.

There were three Sessions, over the four days, involving 26 papers, and a technical tour of the RAE/Bedford simulation facilities, on the afternoon of the third day.

2. REVIEW OF THE TECHNICAL PROGRAM

The Appendix to this report contains the conference program.

There will be no attempt to discuss each and every paper presented at this conference, as this is *not considered to be the objective of the technical evaluation. Comments will be made regarding specific papers however, when there is deemed to be information that should be brought to the attention of the reader of this report. Generally there will be no discussion of papers or presentations of "Facility Description" nature. This is not intended to detract in any way from the worth and interest value of papers not specifically mentioned.*

The Keynote Address, entitled "Manned Flight Simulation - Challenge and Response" was delivered by Mr. John C. Dusterberry, of NASA's Ames Research Center. This address did an excellent job of setting the scene for the conference. Dusterberry set his theme by quoting W. J. G. Pinsker's 1956 comments in the first AGARD report on manned flight simulation: "The pilot controls the aircraft primarily by visual reference to the ground or to instruments and his response to the physical sensation of movement. A successful flight simulator will probably have to produce a convincing analogue of both". It is easy to conclude that Mr. Dusterberry intentionally selected a considerable understatement to establish this point. The principal issue is clearly the question of what constitutes a "convincing analogue" that is adequate for successful simulation. Dusterberry proceeded to bring us forward to the present, suggesting along the way that there is a distinct role for both the Dominant Cue and Multiple Cue simulation devices, depending, among other things, on cost-effectiveness, complexity of the application, and confidence in the results.

In his response to the stated challenge, Dusterberry reminds us of the problems that had to be met, by quoting three points from C. W. Harper's address at the 1964 FMP Symposium, i.e.:

- (1) "Providing an adequate and representative environment to the simulator pilot - - the simulator hardware problem."

Dusterberry pointed out that advances in microelectronics have largely solved the out-the-window visual system problem by digital image-generation techniques. To a very large extent, this is true, with a significant problem still with us however, as pointed out in the very first paper, immediately following. R. S. Bray concludes that even wide field-of-view computer-generated imagery systems still have serious shortcomings in texture and detail to provide simulation adequacy for hover and landing tasks.

- (2) "Providing a sufficiently complete and accurate computing facility and at the same time constraining it to practical limits -- the simulator computer problem."

There seems to be no reason for dispute that this problem has found a successful solution in the recent advances in digital computational hardware. Dusterberry's caution that speed and lower cost can make it possible to acquire hardware requiring excessive software effort is indeed a wise one. Many of us have felt the sting of those excessive software efforts.

- (3) "Choosing the adequacy of the required simulator equipment when there was little directly-applicable quantitative knowledge of human perception on which to base a choice - - the problem of scarcity of knowledge of human perception."

As pointed out, a great deal of work has been done in this area since Harper's 1964 comments. We know considerably more about the issues of human perception, particularly as needed for simulation design and development. However, Mr. Dusterberry is correct when he concludes that it is not likely that a complete and exact understanding of man's perception and response will ever be achieved.

This FMP Symposium on Flight Simulation consisted of three technical sessions:

- I. ENGINEERING, TECHNOLOGY & TECHNIQUES
- II. APPLICATIONS
- III. VALIDATION, CORRELATION AND IN-FLIGHT SIMULATION

2.1 Engineering, Technology and Techniques

This Session consisted of eleven papers (actually 12 presentations, in that Number 6: "Review of AGARDographs" consisted of two excellent discussions of distinctly different topics). There was a good balance of topics faithful to the session title. By this evaluator's very arbitrary measure, there were three papers discussing systems development (Papers 2, 3 and 5), six papers on the subject of simulation technology (Nos. 1, 4, 6a, 6b, 8 and 10), and three presentations of capability status (Nos. 7, 9 and 11).

The paper by R. S. Bray (Paper No. 1) on visual and motion requirements for helicopter simulation was an excellent example of reporting on the findings of simulation technology work, including conclusions on the adequacy (or lack of, in certain instances) of today's CGI and large-amplitude motion capabilities.

Professor L. D. Reid's presentation (Paper No. 4) on application of optimal control techniques described analytical work with some accompanying empirical findings as performed by Reid at the University of Toronto. The application of optimal control to simulation as described in this paper is most challenging indeed, when human response modeling is incorporated. Reid concludes that optimal control techniques can be successfully employed in a number of simulation applications. However, in some cases, such as motion system controllers, they are subject to similar advantages and disadvantages as classical linear washout algorithms.

The AGARDograph review by B. N. Tomlinson, entitled "Simulator Motion Characteristics and Perceptual Fidelity", (Paper No. 6A) was an excellent tutorial on motion systems logic. In it he describes his ongoing work to include amongst others, *motion drive software under the umbrella of AR-144*. Up to this point, AR-144 has described hardware aspects only, and one cannot disagree with the need for inclusion of the software issues in simulation motion logic. In addition, Tomlinson made an offer to establish a repository for information on simulation motion cueing. He solicited contributions from all interested parties. This is an essential ingredient in analyses of this scope.

Paper No. 8 is a technical adjunct to the work reported by Tomlinson, K. J. Staples, et al. reported on the progress of implementing AGARD AR-144 in motion system assessment and monitoring. This is an excellent treatise on the process in the U.K. for acquiring data in accordance with AR-144, including a description of the RAE and Cranfield Institute of Technology development work for the "CIT" motion monitoring system. As commented by Session Co-Chair H. A. Mooij, RAE made exceptional efforts to respond to AGARD needs regarding this work relative to AR-144.

In Paper 6B, A. G. Barnes discussed the simulation of aircraft on, and close to the ground (a summary of AGARDograph AG-285). This paper documents the need for improved modeling and software for simulation of ground roll, an area that has received lesser priority over many years, and yet is a critical aspect of many simulation investigations. It is becoming even more important in the growing field of simulation of V/STOL aircraft. Finally, the very-often overlooked aspect of improved modeling and better understanding of the landing flare is indicated. The suggestion is that a jeopardy exists in that a good simulator will give the impression that the landing flare is more easily manageable than is actually the case.

Notably, this session contained four presentations that included distinct identification of needs for new technology, or research and development requirements.

- o Bray (Paper No. 1), calling for experiments to define adequate field-of-view, and near-field spatial frequency of detail, as well as the generation of information to support the development of practical pilot response models.
- o Barnes (Paper No. 6B), in which he identified the need for improved modeling and software for simulation of aircraft during ground handling conditions.
- o Brauser and Seifert (Paper No. 10), in which they pointed up the need for more research and development into the man-machine interface, and human performance modeling.

- Blatt (Paper No. 11), in his "Futuristic Trend Projections", identifying the need for early work in Artificial Intelligence to contribute to the application of this technology, rather than follow it.

2.2 Applications

This session consisted of eight papers, evenly distributed between presentations on systems development, and facility descriptions.

Included was an excellent description of the control system development for fly-by-wire aircraft, using an Airbus A300 testbed. This work (Paper No. 13), presented by R. Vadrot, was conducted at the French Flight Test Centre (CEV). As part of this work, it is further confirmed that limited field of view detracts from the fidelity of landing flare simulation, and lack of motion is a restricting factor in takeoff rotation, landing touchdown, and ground roll.

2.3 Validation, Correlation and In-Flight Simulation

This session consisted of seven papers, highlighting two significant factors:

- (1) The continued, recognized need to pursue the issues of validation and correlation of ground-based simulation with airborne trials and data, and
- (2) The growth of in-flight simulation as a valuable tool in aeronautical research and development.

Pursuant to validation and correlation, A. M. H. Nieuwpoort, in his paper entitled "Correlation Between Flight Simulation and Processing of Flight Tests Based on Inertial Measurements", stressed the importance of high-fidelity aerodynamic models. This is becoming a more important issue due to the integration of flight controls within the design process, and the need for accurate aerodynamic information in flight management computers. This paper was a very complete dissertation of the correlation issues between flight simulation and flight test. However, the paper raised the old questions regarding the accuracy and validity of in-flight measurements of thrust, drag, and angle-of-attack. It is not clear that these fundamental problems have been solved to a degree that will allow highly accurate correlation.

3 CONCLUSIONS

In terms of meeting the stated objectives, this conference did indeed meet its primary goal; that of "providing an up-to-date description of the state of the art of technology and engineering for both ground-based and in-flight simulators, together with an indication of future possibilities". An arbitrary grouping of the types of presentations yields the following:

Topical Group	No. Papers
◦ Descriptions of Systems Development	5
◦ Reports of Simulation Technology Work (Data, Findings, or Results of Simulation Experiments, or Experience)	8
◦ Status of Capability (Description of Work or Developed Capability at Specific Site)	7
◦ Facility Descriptions	7

This constitutes a balanced cross-section of the overall technical situation in the flight simulation community.

The second objective, i.e.: "Place the roles of ground based simulators and in-flight simulators into context with one another and within the aerospace scene", is more difficult to assess. Certainly, there was excellent coverage of existing and emerging in-flight simulation capabilities. What is not yet clear are the respective roles of in-flight versus ground-based facilities. It can be surmised that, as in-flight simulation capability and technology develops with use, as it surely will in the near future, the contributory roles to the overall aerospace scene will become more evident.

This evaluator is concerned about the paucity of reports presenting specific results of simulation technology research and development. In all probability, the managers and engineers in the simulation community today had their origins in the more established disciplines of the aeronautical sciences. Conferences devoted to those disciplines, Aerodynamics, or Stability and Control, for instances, will almost exclusively contain papers presenting the results of experimental processes, including findings, data, analyses, and conclusions. The flight simulation community tends to talk more about its facilities than the technology that went into creating them. This does not constitute a criticism of presentations of facility descriptions. On the contrary, most of us, in making the transition to flight simulation from other disciplines, have found over the years that understanding and evaluating the facilities and capabilities of other sites has proved invaluable in evaluating and planning our own developments. There is a definite place and need for the interchange of information regarding facility configurations and capabilities at the various member sites.

However, as many of the papers in this conference suggested, there remain serious technology questions in the field of simulation that need answering. We are far from a scientific understanding of such issues as:

- o The adequacy of visual and motion cueing.
- o Quantification of the cost-effective extent of field-of-view, resolution, spatial detail, realism in the visual scene.
- o The problems of adequate math modeling of complex aircraft and environmental conditions vis-a-vis computational throughput and simulation cycle time.

The conclusion drawn from this is that there is insufficient experimental work being conducted and reported on at this and other conferences on Flight Simulation.

In general, it is fair to say that the combination of facility capability development spurred by demands of the training simulation operators, coupled with the technology developments of the R&D simulation community, have contributed to the furtherance of knowledge in this complex field. These developments have indeed been documented in this conference. Certainly the rapid advancements in the state-of-the-art will have a positive impact on both civil and military aerospace planners.

In summary, this conference clearly met its stated objectives. Further, the event was in concert with the mission of AGARD in terms of:

- o Improving cooperation among member nations in Aerospace and Development, and
- o Exchanging of scientific and technical information.

The presence and enthusiastic participation of almost 200 technical people, representing twelve of the NATO nations is a testament to the above.

In addition, AGARD and the Flight Mechanics Panel is to be complimented for the sponsorship of this technical conference on the subject of Flight Simulation. It was best said by John Dusterberry in his keynote address:

"AGARD has played an important role in the development of manned flight simulation. It has brought together people from throughout NATO to share and discuss the newest developments in simulation and their uses in aircraft research, development, and design. AGARD has played an active role through its working groups, where the requirement that a written report be produced that is acceptable to all members means the facing of issues that an individual might otherwise avoid."

4. RECOMMENDATIONS

The Flight Mechanics Panel should recognize and take action to disseminate the need for continued emphasis on simulation technology research and development regarding adequacy of cueing systems for specific simulation applications.

The demand for piloted flight simulation capability is constantly growing, both to support requirements for training, and for research and development of more complex aircraft and aircraft systems. Hence, the technology of flight simulation must advance at a pace sufficiently rapid to provide the degree of fidelity and utility necessary to meet the demand. The operators of R&D simulation facilities cannot afford to wait for these technology advances to come solely from the simulation systems builders. Much work needs to be done to identify what needs to be known and developed to provide for this demand in capability.

The FMP should consider organizing a subcommittee, or "Working Group" for simulation facilities. This concept has proved extremely fruitful in the United States, as part of the AIAA Flight Simulation Technical Committee. Such a working group would consist of simulation facility operators, who would meet periodically for the purpose of interchange of information on facility capabilities. Meeting locations would rotate among member sites to allow for tours and facility descriptions conducted by the "host" member. This process would tend to diminish the presentation at formal symposia of the more mundane aspects of facility descriptions. Several papers in this conference dealt at some length upon development of capabilities that have been present at many sites for some time. It is difficult for any Technical Program Committee to recognize and screen these papers on the basis of submitted abstracts. The "Working Group" concept however, would provide a forum for interchange of information on simulation capabilities, allowing for everyone concerned to be aware of the current state-of-the-art. Moving the emphasis of facility and capability interchange from the symposium to the working group process would provide the time and effort for the TPC to concentrate on the encouragement of experimental technology findings in future symposia.

Such a Subcommittee could evolve from the existing FMP Subcommittee 03 or be constituted separately. It is the understanding of this reviewer that FMP S-03 has a primary responsibility to study the issues of simulation motion systems. In any event, it is believed that such a "Working Group" concept would be of significant value to the simulation community within AGARD.

MANNED FLIGHT SIMULATION--CHALLENGE AND RESPONSE

John C. Dusterberry*
 NASA Ames Research Center
 Moffett Field, California 94035, U.S.A.

SUMMARY

Early AGARD papers on manned flight simulation describe the status of an emerging test technique and then offer suggestions of problems that should be solved to advance the technique and predictions of the results that will be obtained by its use. Later AGARD literature is examined to determine how these challenges have been met, both in ground-based and in-flight simulation and how AGARD has played an important role in advancing the technique so that it is now an integral part of the aerospace vehicle design process.

INTRODUCTION

Even before his first powered flight, Wilbur Wright recognized the problems of integrating the man and the flight vehicle. In 1901 he said, "Man already knows how to construct wings or aeroplanes, which, when driven through the air at sufficient speed, will not only sustain the weight of the wings themselves, but also that of the engines and the engineer, as well. Men also know how to build engines and screws of sufficient lightness and power to drive these planes at sufficient speed Inability to balance and steer still confronts students of the flying problem When this one feature has been worked out, the age of the flying machine will have arrived, for all other difficulties are of minor importance." (Ref. 1)

With difficulty the Wright brothers found how to balance and steer their flying machine, but it still remained a problem to teach others. Starting about 1910, all manner of training simulators were employed to teach others how to fly and how to alter the man's knowledge to fit the machine he operated. However, as man attained skill in constructing flight vehicles he found that those machines had to be designed to be compatible with the men who would operate them; that is, the machine had to be made to fit the man. The answer lay in the research and development simulator. The development of research and development simulators drew on the early experience gained in training simulators and progressed through a series of steps that can be traced in the publications of AGARD, which played an important role in their development. Progression from one step to another depended both on the confidence of pilots and engineers that the information obtained from simulators could be depended on for use in vehicle design and on technical and scientific advances that made it possible to build simulators that presented the pilot with a better simulation of flight cues.

THE CHALLENGE

"The science of engineering is that of predicting the performance of machines. If man controls the machine we have to study the complete system with the human operator as an integral part. To improve performance of the system, the machine has to be modified to suit the human controller and the controller has to be modified to suit the machine. If man's limits are reached, the designer will replace him with automation. However, man can discriminate and adapt himself, he is the supreme servomechanism. The human pilot is still the only controller who can cope with emergencies, will resist detection by jamming and decoys. It is difficult to conceive that he will not continue to control aircraft for years to come. In order to utilize his skill efficiently we will have to learn to understand his faculties." This was W. J. G. Pinsker's opening statement in his 1956 presentation of the first AGARD report on manned flight simulation (Ref. 2). It is a succinct statement of the system design problems for which flight simulation has proved to be a most successful and economic tool. In his concluding remarks, Pinsker set goals for the simulator designer and user: "The pilot controls the aircraft primarily by visual reference to the ground or to instruments and in response to the physical sensation of movement. A successful flight simulator will probably have to produce a convincing analogue of both." His prediction of the future is conservative: "It is not inconceivable that in the not very distant future, an aircraft control system can be designed and properly matched to the aircraft by studying it in a flight simulator."

A continuing objective of aircraft designers and builders is to develop aircraft and their systems and to bring them to operational status as expeditiously and economically as possible. Simulation is, of course, only one of the tools used in attaining this objective. There have been a number of steps in the progress of research and development simulators, steps that have been determined by aircraft development goals and made possible by scientific and technological advancements.

RUDIMENTARY SIMULATORS

The availability of analog computing techniques in about 1945 was critical to the development of the simulator for aircraft research and development purposes. With the exception of training-simulator developers, who were already using the technique, it is likely that no aeronautical organization bought its

*Retired.

first computing apparatus for the purpose of using it in the assembly of a man-in-the-loop simulator. Instead it was bought to solve the organization's most intractable problems, the ones that could be formulated well but were difficult or time-consuming to solve because they contained many differential equations and nonlinear functions. The speed with which these computing techniques could solve problems, particularly optimization problems, attracted new users to the computing apparatus, and soon the techniques began to be used on real-time problems. The new users wheeled this early computing apparatus up to aircraft test stands and to airplanes on the ground in efforts to resolve some of their automatic system problems, including the development of the newly emerging variable-stability aircraft. The apparatus was even applied to that most intractable of all problems, control systems involving man. Rudimentary research and development simulators apparently emerged at about the same time at a number of different locations. They comprised little more than (1) the computing apparatus connected to a control device; (2) at least one simulated instrument, probably a voltmeter or a horizon line on a cathode-ray tube; and (3) the all-important man.

DOMINANT-CUE SIMULATORS

Only limited results could be obtained with those first simulators, but they were good enough to encourage the research and development workers to proceed to the dominant-cue simulator--a simulator that presents to the pilot a good simulation of the cue that dominates his perception and affects his response in the task to be studied. Important factors in the decision to proceed to this class of simulator were the existence of a problem, confidence that simulators could be used in aircraft research and development, and the availability of the technology necessary to build such a simulator. The problem was man and the inability to define precisely enough his action as a controller, to understand his faculties. The most important of the new technology was what was called the general-purpose analog computer, designated in Fig. 1 as the electromechanical computer, since it still contained mechanical elements. However, this new class of computers used chopper-stabilized amplifiers, which provided a great increase in the consistency of results. Servo-set potentiometers and interchangeable patch boards provided the ability to use the same computer on more than one problem at different times of the day, and for the programming connections to be made without interfering with other users. Thus, the computer was available to several users and no longer had to be part of the simulator or other hardware involved in a real-time problem.

The characteristics of a particular dominant-cue simulator were dependent on the particular problem set it was designed to solve, and its design was likely to have drawn heavily on precedents in techniques and equipment of already-successful training simulators. For the simulator described in Pinsker's first AGARD paper, the man-in-the-loop problem was tracking, and the dominant cue was visual. For other investigators, their man-in-the-loop problems were best solved by providing the inertial cues of motion.

Papers describing research results obtained from these dominant-cue simulators appear in the AGARD Flight Mechanics Panel literature of about 1960 to 1963. Examples of the reporting of these kinds of results on generic problems include the papers of Cooper (Ref. 3) and Barnes (Ref. 4) on takeoff and landing research. (Cooper's 1958 paper, presented before the same Panel, described the same sort of work done by flight research and described by Drinkwater et al. in Ref. 5) By 1961 the Flight Mechanics Panel was able to devote an entire session of its symposium to the emerging art of simulation. In addition to a paper on mathematical modeling by Brown and Paddison (Ref. 6), Westbrook spoke on simulation in modern aircraft design (Ref. 7), and indicated that Pinsker's goal of designing specific aircraft systems had been met. Rathert et al. described the use of piloted simulators in general research (Ref. 8). Since the introduction of simple variable-stability aircraft in the late 1940s, the capabilities of those vehicles had been increased to the point at which they could be called in-flight simulators, and Kidd et al. could title their paper, "In-Flight Simulation--Theory and Application." (Ref. 9)

Critical to the acceptance of this class of dominant-cue simulators by pilots and engineers was the demonstration of their usefulness in studies of essentially unprecedented vehicles and in studies of missions in environments that at the time could only be simulated and not experienced. In this 1960-1963 period, A'Harrah reported on his investigations of the low-altitude, high-speed handling and riding qualities of aircraft (Ref. 10); Neil Armstrong, the first man on the Moon, and Euclid Halleman described the use of in-flight simulation in the space program (Ref. 11). Results of the kind reported in those papers were critically important to the advancement of the simulation. Simulation was used for such studies because there was no alternative way to do the work. The use of a particular dominant-cue simulator might be largely limited to a particular flight segment in which there was an easily chosen dominant cue that the simulator could accurately reproduce, but both engineers and pilots could place enough confidence in the results to move into the next class of simulators--multiple-cue simulators. Curiously, results obtained in simulations of unprecedented vehicles were accepted for use in the design of those vehicles before such results were accepted for use in the design of vehicles for which many design precedents existed.

MULTIPLE-CUE SIMULATORS

Acceptance of the dominant-cue simulators elicited confidence in the transition to multiple-cue simulators, which provided a wider range of cueing devices. That this transition was occurring can be seen in the contents of the 1964 meeting of the Flight Mechanics Panel, the first FMP meeting devoted entirely to manned flight simulation (Ref. 12). Papers presented at that meeting described the results of studies carried out in dominant-cue simulators, and all of the authors spoke of the constraints imposed upon their results by the limitations of the simulators used. The limitations derived both from the failure of the simulators to reproduce faithfully some of the cues and from the author's incomplete understanding of the effect of the

total absence of others. The paper in Ref. 12 simulator hardware described lies on both sides of a dividing line between dominant-cue simulators and multiple-cue simulators. And the author of the paper on computing facilities could only foresee the application of all-electronic digital computers in a research and development setting, even though such computers were already being used in training simulators.

In his introduction to that 1964 FMP symposium, Harper (Ref. 12) summarized the simulator and experimental design problems that had to be met, if simulation techniques were to be developed in a straightforward manner:

1. Providing an adequate and representative environment to the simulator pilot--the simulator hardware problem
2. Providing a sufficiently complete and accurate computing facility and at the same time constraining it to practical limits--the simulator computer problem
3. Choosing the adequacy of the required simulator equipment when there was little directly-applicable quantitative knowledge of human perception on which to base a choice--the problem of scarcity of knowledge of human perception

The response to these challenges will be considered below.

The multiple-cue simulator, the problems that directed its development, and the technology that allowed it to be developed are shown in Fig. 1. The confidence that pilots and engineers had come to place in the results obtained with earlier simulators confirmed that the technique could be used to produce design-useful results. Total vehicle design, including the integration of the various on-board and ground-based systems, was the problem that multiple-cue simulators could solve. It is interesting to note that the problems involved in total design are, in a sense, less difficult. Since simulation worked well on problems for which no alternative testing methods were available, the goal became one of using the technique on problems for which other but more expensive solution methods existed. The improved technology of television made possible better out-the-window visual systems. Fully electronic digital computing, which had been demonstrated in a training simulator in 1960, had advanced so that it could be usefully applied in research and development simulators. The transition from a dominant-cue simulator to a multiple-cue simulator was sometimes a gradual one--for example, an existing simulator might be modified by adding a better visual system, a platform motion system, or audible-cueing equipment, by generally upgrading the cockpit instrumentation. Sometimes the transition was more drastic--the building of an entirely new simulator.

By 1968, in the AGARD Lecture Series on The Aerodynamics of V/STOL Aircraft, Yaggy devoted several thousand words to describing the uses of simulation in V/STOL research, development, and design and asserted that ". . . the degree of sophistication which was begun in the fifties for aircraft simulation was well beyond that which had been accomplished in any previous time period." (Ref. 13) Yaggy also discussed the limitations of simulation, but nonetheless called the results "meaningful and gratifying."

That simulation was becoming a mature experimental technique in the late 1960s can be inferred both from the increasing number of AGARD papers on simulation during that period and from the contents of the 1970 AGARD Flight Mechanics Panel Symposium on Simulation (Ref. 14). Previous AGARD papers had described successful results, but simulator users present at that symposium were prepared to be retrospective, to analyze simultaneously the results of a number of simulations, to look for common successes and limitations, to draw conclusions on facility and experimental requirements, to teach, and to learn. The organizers of the conference specifically invited papers on the objectives of simulation; on the mathematical models used; on the motion, visual, and aural cues; on the cockpit environment; on the choice of simulators; and on the design of experiments. The presentation of each paper was followed by discussions of other points of view, and those in attendance at the conference were encouraged to share their experiences and opinions on these subjects.

Five years later, in 1975, there was solid evidence that the goals of preliminary vehicle design validation and flight-test planning had been reached, aided by the use of multiple-cue simulators. The results can be seen in Spitzers's paper on the use of a flight simulator in the design of the YC-14 (Ref. 15), presented at that year's Flight Mechanics Panel Symposium on simulation. Spitzer's paper showed that multiple-cue simulators helped him reach his goals of preliminary vehicle design validation and flight-test support, including pilot training. He was careful to point out, however, that although multiple-cue simulators were important to the critical testing involving more than a single mission segment or a single aircraft system, much simpler simulators were also used in the YC-14 design, and they were adequate and economical in many design phases. In the preface to the proceedings of that symposium, cochairmen Leonides and Gerlach summarized the symposium round-table discussion in which two of the points that were raised were the same as those brought up by Harper 11 years before in Ref. 12: the necessity of improving the cue-producing hardware, particularly the visual, and the necessity of better understanding man's perception and use of cues in a simulator. They also underscored the point made by Spitzer that the most cost-effective simulator is not necessarily the most elaborate one.

THE SIMULATORS OF TODAY AND TOMORROW

The beginnings of the transition to the simulators of today and those of tomorrow can be seen in the proceedings of AGARD's 1978 Symposium on Pilot Aircraft Simulation Techniques (Ref. 16). A range of simulation topics was covered by the papers presented at that meeting, but this time a larger portion of the

proceedings was devoted to finding the elusive answer to the problem of understanding the man and his perception of cues in an aircraft and how such information could be used in simulator design. A reading of the conference proceedings shows that problems were arising in relation to flight vehicles that were more difficult to control, particularly in the man-machine interface. The authors of the papers contained in Ref. 16 seemed confident that multiple-cue simulators had been successfully applied to the solution of similar problems in the development of earlier aircraft, and they wanted to construct new simulators that would be equally applicable to these newer, less-docile flight vehicles. More was known about the man, and more was known about how the advances in technology could be applied to the solution of simulator problems. These technological advances had taken place primarily in microelectronics, and they heavily influenced the ability of simulator designers to produce better out-the-window visual systems. This improved understanding of man and of his perception of flight cues allows us to apply the technological advances in an intelligent and economic manner. The research and development needs for tomorrow's simulator can be seen emerging in those papers from the 1978 Flight Mechanics Symposium on Simulation.

There remain many applications for dominant-cue and multiple-cue simulators, and it is worthwhile to assess the uses and costs, as well as the reliability of the results obtained with the various classes of ground-based simulators. The measure of the complexity of the real-life task (Table 1) includes the range of vehicle types and their systems, the percentage of vehicle mission that can be simulated, and the difficulty of the pilot-operator's task. The confidence in the results obtained with the dominant-cue simulator may seem low to some users, and it should be remarked that the range would be higher if one could be certain that omitted cues or cues that were poorly presented were not important to the test conducted. Therefore, experimental design is an important factor in the reliability of the results. More cues are simulated well in the multiple-cue simulator, but at an increase in operating cost as well as in first cost. Confidence in the multiple-cue results is higher, but again at a higher cost. Experimental design and the effectiveness with which the simulator is used, will greatly influence the complexity of the real-life task an experimenter can undertake to simulate. In tomorrow's simulators, an increase in all the numbers can be foreseen. The ultimate objective is expeditious and economic flight-vehicle development. An increase in simulation cost can be justified if simulation decreases the total cost of developing a vehicle.

One conclusion that can be drawn from Table 1 is that not all simulations should be conducted on tomorrow's advanced simulators. There are many aircraft research and development tasks, many systems problems and generic problems, that still can and should be investigated on dominant-cue or multiple-cue simulators. In-flight simulators (Table 1), should be subdivided, to reflect more accurately their use. The relatively wide range of values is a result of the fact that some of these simulators are designed primarily for helicopters and others primarily for different types of aircraft.

THE ROLE OF AGARD IN SIMULATION

AGARD has played an important role in the development of manned flight simulation. It has brought together people from throughout NATO to share and discuss the newest developments in simulation and their uses in aircraft research, development, and design. AGARD has played an active role through its working groups, where the requirement that a written report be produced that is acceptable to all members means the facing of issues that an individual might otherwise avoid. These AGARD publications include advisory reports on simulator visual systems (Ref. 17), on platform motion systems (Ref. 18), and on future requirements for airborne simulation (Ref. 19).

The foregoing has summarized the work of AGARD's Flight Mechanics Panel, but important contributions to simulation techniques have also been forthcoming from the Aerospace Medical Panel, the Avionics Panel, and the Guidance and Control Panel. Even the Propulsion and Energetics Panel has published a paper involving a manned flight simulation. Since avionics equipment uses much of the same hardware that is used in simulators, it is natural that new avionics equipment and techniques reported by AGARD include the use of simulation in their development. Similarly, guidance and control uses techniques in common with simulation, so the reports of that symposium more often include man-in-the-loop simulations. The symposium held last spring by the Guidance and Control Panel (Ref. 20) is of particular interest, since it describes several new helicopter simulators in France, Germany, and the United States. The Aerospace Medical Panel has published a large amount of work, both on psychophysiological characteristics of the human and on training-system requirements. These include several conference proceedings, as well as such titles as "The Use of Simulators for Training In-Flight and Emergency Procedures" (Ref. 21); "Mathematical Models of Human Behavior" (Ref. 22); and "Human Factors Topics in Flight Simulation" (Ref. 23), an annotated bibliography. The advisory report "Fidelity of Simulation for Pilot Training" (Ref. 24), prepared at the joint request of the Flight Mechanics Panel and the Aerospace Medical Panel, is particularly interesting, because it is the work of a group of individuals of diverse scientific and technical backgrounds.

RESPONSE TO THE CHALLENGE

Early authors made problem statements and predictions to the Flight Mechanics Panel. Those statements and the subsequent Flight Mechanics Panel literature can be examined to determine if the problems have been solved and the predictions fulfilled, that is, if the challenges have been met. The first paper by Pinsker (Ref. 2) predicted the early design of an aircraft system using simulation as a technique, and Westbrook's paper 4 years later (Ref. 7) indicated that the challenge had been met.

In AGARD's first symposium on simulation, Harper posed the three problems mentioned earlier that had to be solved in advancing the simulation technique (Ref. 12). The first was the simulation hardware problem,

or how to provide adequate cues to the simulator pilot. Although this problem must be faced in the design of each new simulator or simulation subsystem, advances in microelectronics have largely solved the out-the-window visual system problems by digital image-generation techniques, especially when a wide field of view is required. This solution may be relatively expensive, but it is a solution.

The second problem posed by Harper was the simulator computer problem--how to provide adequate computing power and at the same time constrain the computing facility to practical limits. Once more, microelectronics and digital computers have solved the hardware problem. It is likely that constraint is still required because of the software problems. The increase in speed and decrease in price of digital computers make it possible to install a computer requiring an excessive software and programming effort.

Harper's third problem was the problem of the scarcity of information about human perception--the difficulty of specifying the cues to be presented to the simulator pilot without understanding his perception of those cues. A great deal of work has been done on pilot perception and pilot modeling since 1964 and many answers have been provided. Experience gained in more and more simulations has provided information from which engineering solutions are derived. Simulator specifiers and designers know much more about the cues required by the pilot for a given test, but it is not likely that a complete and exact understanding of man's perception and response will ever be achieved. If it should be, there would be no need for either simulator pilots or airplane pilots.

REFERENCES

1. McFarland, M. W., ed.: The Papers of Wilbur and Orville Wright. Vol. 1, McGraw-Hill, New York, 1953, pp. 90-100.
2. Pinsker, W. J. G.: The Flight Simulator in Aircraft Control and Design. AGARD RP-71, 1956.
3. Cooper, George E.: The Use of Piloted Flight Simulators in Takeoff and Landing Research. AGARD RP-430, 1963.
4. Barnes, A. G.: Simulator Assessments of Takeoff and Landing. AGARD RP-432, 1963.
5. Drinkwater, F. J. III; Cooper, George, E.; and White, M. D.: An Evaluation of the Factors Which Influence the Selection of Landing Approach Speeds. AGARD RP-230, 1958.
6. Brown, W. S.; and Paddison, D. I.: Mathematical Models for Missiles. AGARD RP-367, 1961.
7. Westbrook, C. B.: Simulation in Modern Aero-Space Vehicle Design. AGARD RP-366, 1961.
8. Rathert, G. A., Jr.; Creer, B. Y.; and Sadoff, M.: The Use of Piloted Simulators in General Research. AGARD RP-365, 1961.
9. Kidd, E. A.; Bull, G.; and Harper, R. P., Jr.: In-Flight Simulation--Theory and Application. AGARD RP-368, 1961.
10. A'Harrach, Ralph C.: Low-Altitude, High-Speed Handling and Riding Qualities. AGARD RP-443, 1963.
11. Armstrong, Neil A.; and Holleman, Euclid C.: A Review of In-Flight Simulation Pertinent to Piloted Space Vehicles. AGARD RP-403, 1962.
12. Harper, C. W., ed.: Simulation for Aerospace Research. AGARDograph 99, 1964.
13. Yaggy, P. F.: Flight Testing and V/STOL Handling Requirements. The Aerodynamics of V/STOL Aircraft, AGARDograph 126, 1976, pp. 429-500.
14. Simulation. AGARD CP-79, 1970.
15. Spitzer, R. E.: Use of the Flight Simulator in YC-14 Design. Flight Simulation Guidance Systems Simulation, AGARD CP-198, 1975, pp. 7-1 to 7-14.
16. Piloted Aircraft Environment Simulation Techniques. AGARD CP-249, 1978.
17. Characteristics of Flight Simulator Visual Systems. AGARD AR-154, 1981.
18. Dynamic Characteristics of Flight Simulator Motion Systems. AGARD AR-144, 1979.
19. Buhrman, J.: Future Requirements of Airborne Simulation. AGARD AR-188, 1984.
20. Helicopter Guidance and Control Systems for Battlefield Support. AGARD CP-359, 1984.
21. Eddowes, Edward E.; and Waag, Wayne L.: The Use of Simulators for Training In-Flight and Emergency Procedures. AGARD AG-248, 1980.

K-6

22. McRuer, Duane T.; and Krendel, Ezra S.: *Mathematical Models of Human Pilot Behavior*. AGARD AG-188, 1974.
23. Hunter, S.; Gundry, A. J.; and Rolfe, J. M.: *Human Factors Topics in Flight Simulation: An Annotated Bibliography*. AGARD R-656, 1977.
24. *Fidelity of Simulation for Pilot Training*. AGARD AR-159, 1980.

ACKNOWLEDGMENTS

The author wishes to thank Mr. D. L. Key and Mr. C. W. Harper for their assistance in the preparation of this paper. Conversations with Mr. Key helped develop the concept of the complementary developments of research needs and available technology. Mr. Harper provided the ideal combination of enthusiastic encouragement and perceptive criticism, as he has throughout the author's professional career.

Table 1. *An Assessment of Research and Development Simulators*

Simulator	Complexity of real-life task ^a	Cost of simulation ^a	Confidence in results ^a
Dominant-cue	1 - 4	1 - 5	4 - 6
Multiple-cue	5 - 8	4 - 7	6 - 8
"Tomorrow's"	8 - 10	8 - 10	6 - 10
In-flight	4 - 9	7 - 10	6 - 10

^a1 = lowest; 10 = highest.

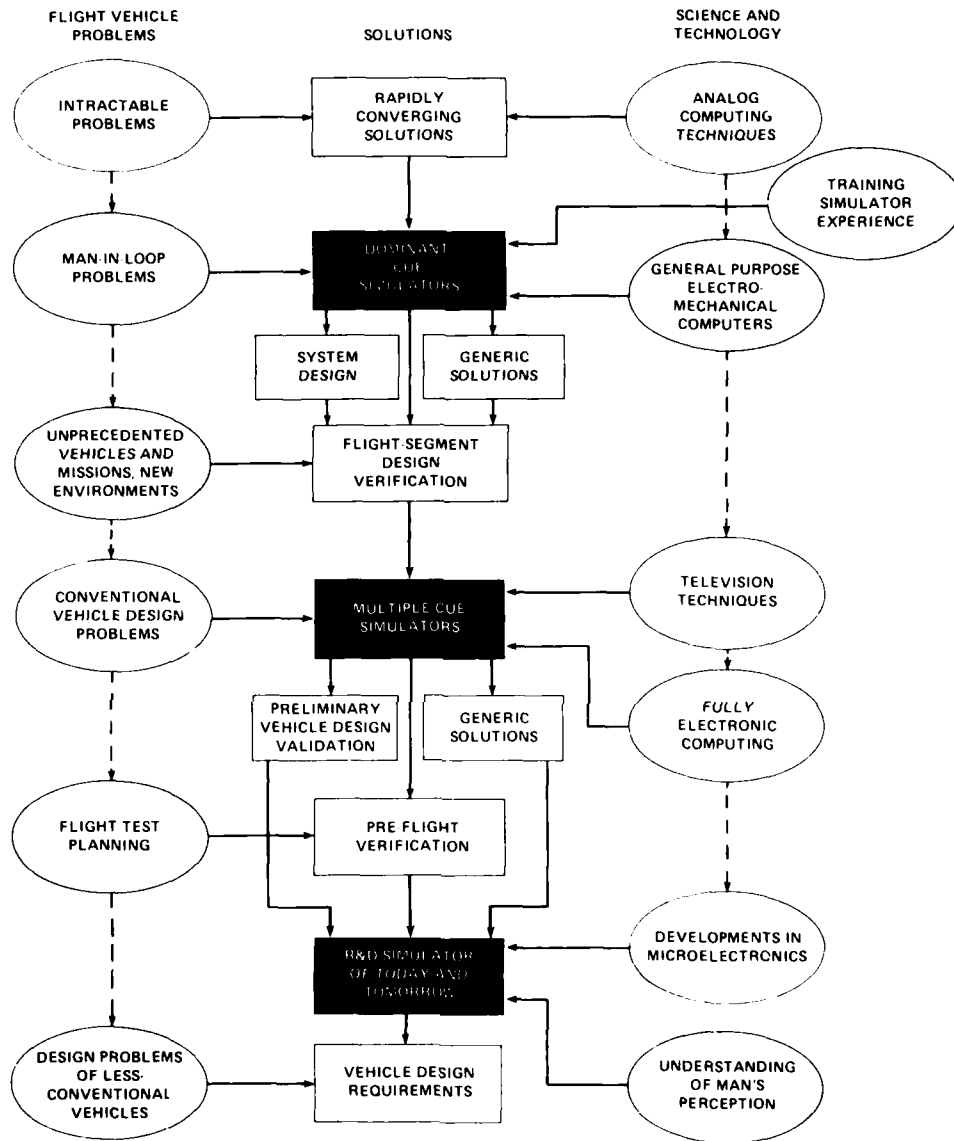

Fig. 1. The development of research and development simulators.

VISUAL AND MOTION CUEING IN HELICOPTER SIMULATION

Richard S. Bray

NASA Ames Research Center
Moffett Field, California 94035, U.S.A.

SUMMARY

For the past decade, helicopter handling qualities have been the subject of piloted-simulator programs at Ames Research Center. Early experience in fixed-cockpit simulators, with limited field of view, demonstrated the basic difficulties of simulating helicopter flight at the level of subjective fidelity required for confident evaluation of vehicle characteristics. More recent programs, utilizing large-amplitude cockpit motion and a multiwindow visual-simulation system have received a much higher degree of pilot acceptance. However, none of these simulations has presented critical visual-flight tasks that have been accepted by the pilots as the full equivalent of flight. In this paper, the visual cues presented in the simulator are compared with those of flight in an attempt to identify deficiencies that contribute significantly to these assessments. It is suggested that a non-optimum distribution of field-of-view elements, coupled with a severe lack of near-field detail, compromises the pilot's sensing of translational rates relative to nearby terrain or the landing surface. For the low-amplitude maneuvering tasks normally associated with the hover mode, the unique motion capabilities of the Vertical Motion Simulator (VMS) at Ames Research Center permit nearly a full representation of vehicle motion. Especially appreciated in these tasks are the vertical-acceleration responses to collective control. For larger-amplitude maneuvering, motion fidelity must suffer diminution through direct attenuation or through high-pass filtering "washout" of the computer cockpit accelerations or both. Experiments were conducted in an attempt to determine the effects of these distortions on pilot performance of height-control tasks. Results revealed that in holding position in the presence of vertical disturbances, pilot control-gain and resultant open-loop crossover frequency were significantly depressed as the fidelity of vertical motion was reduced. In height tracking of a moving reference, gain and crossover were not greatly affected, but phase margin and tracking performance improved with motion fidelity. Pilot-opinion ratings of varied vehicle vertical-response characteristics were significantly modified by changes in motion-cue fidelity.

INTRODUCTION

Subjective fidelity, or a sense of realism, in the flight simulator is essential to productive use in research or training. Depending on the nature of the simulated flight task and the objectives of its use, varying degrees of objective, or engineering, similarity to the flight situation are required to create that realism. With effort, verified dynamic mathematical models of flight vehicles can be realized, and cockpit displays and controls can be duplicated. In two important areas of aircraft-state feedback to the pilot, however, the ground-based simulator usually fails to achieve a high level of objective fidelity. These are, of course, the representation of the scene outside the aircraft, and cockpit motion. The effects of these deficiencies, that is, their individual contributions to the diminution of subjective fidelity, are not clearly understood.

The experience at Ames Research Center has made it obvious that the subjective fidelity of helicopter simulation is especially sensitive to visual- and motion-cueing deficiencies. This sensitivity should not be unexpected in light of the experience with conventional aircraft simulation which has shown a tendency to produce exaggerated handling-qualities difficulties in simulations of vehicles with reduced stability, high control sensitivities, and cross-axes control coupling. Even the best helicopters tend to fit that description. Helicopters add a challenge to simulation technology because of the kinds of critical flight tasks they require in research evaluations and training. In recent programs, attempts have been made to simulate autorotation landing, landing aboard ship in adverse conditions of wind and sea-state, and helicopter air combat close to the terrain.

The primary simulation facility at Ames Research Center, the Vertical Motion Simulator (VMS), can provide unusual fidelity of cockpit motion in the low-amplitude maneuvers associated with hover and landing. However, it is in this flight regime that visual-cueing capabilities are critical. The rapid growth of computer-graphics technology is providing the simulation community with visual-simulation systems that are much more capable than that which is the subject of discussion in this paper. On the other hand, it is unlikely that many motion systems as large as the VMS will be constructed. This review of recent simulation experience at Ames has two objectives: (1) to formulate recommendations regarding the application of new visual simulation capabilities, and (2) to increase the understanding of the role of cockpit motion cues and the penalties that might be experienced by their absence or distortion. The Ames simulation capabilities are described, and the subjective assessment of the fidelity of recent helicopter simulations is discussed. A review of apparent limitations of the visual-cueing system is followed by the presentation of the results of tests that examined the relationship between vertical-motion fidelity and performance in height-control tasks. An assessment of helicopter simulation technology at Ames Research Center in 1982 is included in Ref. 1. This present paper can be considered an update of that report.

THE SIMULATION FACILITY

Flight simulation has been a research activity at Ames Research Center for the past 30 years, and for the past 20 years Ames has operated visual simulation and large-amplitude cockpit-motion devices.

However, when helicopter research became a simulation objective nearly a decade ago, it became obvious that facilities then useful for simulating conventional aircraft were poorly configured for use in studies of rotary-wing handling qualities. The advent of the VMS in 1982 effected a reduction in these constraints. Since the discussions in this paper are for the most part related to experience with the VMS facility, its characteristics will be described in some detail.

The VMS includes four reconfigurable cockpits, or cabs, that can be operated in a fixed mode or mounted on the large-amplitude VMS motion system. The cabs include various arrangements of collimated video monitors for presentation of simulated visual scenes generated by a Single-Link DIG I computer-graphics system. The interior of one of the cabs, configured for helicopter simulation, is illustrated in Fig. 1. The three primary windows are of the conventional 46° by 34° format, and the lower "chin" window is 24° by 34°.

A cab is shown mounted on the motion system in Fig. 2. The cab is driven in rotational motions by a small, six-hydraulic-actuator "synergistic" device. This is mounted on a horizontally driven carriage with 12 m of travel along a beam which in turn can be moved vertically in a 17-m envelope. The second horizontal motion is limited to that which can be provided by the six-post system (about 1 m). However, alternative orientations of the cab allow either fore-and-aft or lateral motion to be represented by the large-amplitude horizontal drive. Specifications for the visual and motion systems are given in Table 1.

SIMULATION FIDELITY ASSESSMENTS

Before the VMS was available, helicopter simulation was often conducted in a fixed cockpit, with a single-window, forward field of view generated by a TV-model-board system. In comparison, the capabilities of the VMS provide a marked improvement in the subjective fidelity of helicopter simulation. The four-window visual system obviously constitutes a primary contribution, at least according to pilot comments; also, it permits the simulation of flight tasks that are not practical with only a single forward window. But in the same period, the dynamic models have improved in quality through more concerted efforts at verification, and cockpit motion is now included in all simulation programs addressing handling-qualities issues. This progress has produced the following advancements: (1) the time required for a pilot's performance in an unfamiliar vehicle and task to reach a plateau is shorter; (2) maneuver amplitudes and control "style" compare more favorably with those of flight; (3) there is less variation in performance and assessment across a group of pilots; and (4) ratings and commentary regarding handling qualities appear to be offered with greater confidence.

But pilot criticism of simulation did not disappear with the advent of the VMS. Complaints of motion roughness and noise, occasional occurrences of "simulator sickness" brought on by poorly configured motion, and references to "lack of depth perception" are still with us, although they are not the barriers to successful research that they were in earlier days. We are left with more subtle questions, however, discrepancies that are obvious only when opportunities are presented to compare directly flight and simulator experiences. Then, the most critical tasks are frequently judged to be more difficult in the simulator than in flight. In recent VMS operations, some degree of flight-simulator comparison was seen for five aircraft: the XV-15 Tilt Rotor Research Aircraft, the H-60 Blackhawk, the SH-2 LAMPS helicopter, the SH-60 Seahawk, and the Harrier VTOL fighter. Reference 2 addresses the XV-15 simulation experience, which spanned nearly the full decade of Ames helicopter simulation history. The most recent simulation, in the VMS, was assessed as a very good reproduction of the aircraft, though visual-system time delays were suspected in some instances of low augmentation-off stability. In the case of the XV-15, the simulation capabilities were not stressed with complex flight tasks; instead, the simulation was flown with some of the conservatism seen in flight tests. The Blackhawk simulation was conducted with the specific objective of fidelity assessment; it was coordinated with flight tests to obtain aircraft-describing data for model verification, as well as to obtain pilot assessments of the aircraft in maneuvers duplicated in the simulator. In Ref. 3, it is reported that the pilots perceived the simulated aircraft to have generally poorer handling qualities than the aircraft it represented. In light of what was considered to be positive model verification the cueing systems were questioned. The other three simulations featured the task of shipboard landing in adverse sea-states for evaluations of control augmentation and displays. The SH-2 (Ref. 4) and SH-60 simulations received generally good marks except for an apparent exaggeration of task difficulty near touchdown, especially in higher wind conditions. There is some reason to suspect the turbulence model and the modeling of the aircraft's response to it, but it is probable that visual-cueing deficiencies were also a source of the difficulty. The most common observation by the pilots was an unrealistically high work load in nulling translational velocities in hover before touchdown. In particular, the perception of the onset of horizontal velocities appeared to be delayed.

Although these simulations are considered to be effective, the failure to achieve the desired level of subjective fidelity creates the discomfiting obligation to qualify the experimental results. Remaining deficiencies must be accurately defined so that improvements can be made. Pilot commentary has not been particularly helpful in identifying sources of cue deficiency: pilots rarely verbalize clearly regarding deficiencies in motion or visual cues unless the problem exhibits itself as an obvious and distracting artifact. A pilot is probably no more practiced at analyzing his use of visual and motion feedback than is the average automobile driver. What will be attempted here is an examination of the limitations of our cueing devices when applied to simulations of typical helicopter flight tasks, and some reasoned speculation about how these constraints might be limiting the fidelity of the simulations. In the following sections, field-of-view issues and, to a lesser extent, the limitations in scene detail are discussed. The fidelity of VMS cockpit motion cues is examined, and some experimental evidence regarding

the effects of vertical-motion-tue distortion on handling-qualities evaluations and on pilot-control bandwidth is offered.

VISUAL-SIMULATION FIDELITY

Field of View

In comparison with the single-forward-window scene provided by the TV-model-board system, the four computer-generated-image (CGI) scenes seemed at first to answer all the requirements for visual simulations in critical helicopter flight tasks. But with the simulation of shipboard landing, nap-of-the-Earth (NOE) operations, and autorotation came the reminder that even those four windows, at least as they are configured in the VMS, fall short of providing the visual information available in flight. Simulator fields of view are compared with those of an OH-58 helicopter in Figs. 3 through 6.

A representation of the pilot's view from the OH-58 at hover is shown in Fig. 3a. A wide-angle photograph (120° by 96°) of the Ames ramp area, from a height of 35 ft, is masked to present a single-eye-point field-of-view. Even this wide-angle scene does not include all of the potentially valuable viewing area of the helicopter, notably that to the right and down through the side door. At 15° nose-up (Fig. 3b), the view of the ramp ahead is relatively unrestricted. For comparison, the same scene is shown through the four-window viewing area of a VMS cab in Fig. 4. (The other available window arrangement has a larger lower-right window, but there are wider gaps between the center, upper-right, and lower-right windows.) In hover (Fig. 4a), a gratifying scope of visual information is included. However, in precision hover to touchdown, especially on the small landing surfaces of ships or drilling-rigs, a sense of visual-field limitation is experienced with this configuration. Even in a runway depiction, visual workload seems high. Deficiencies in scene detail, discussed in the next section, may be the major part of this problem, but as we speculate on the location of the high-priority viewing areas, and recognize the somewhat conflicting visual-cueing needs for attitude and position control, the argument can be made that the viewing area provided by the four windows is poorly distributed.

Visual information vital to control of velocities and position during hovering approach to touchdown is contained in the relatively near-field, that is, at least 20° to 30° below the horizon; however, sustained fixation at depressed viewing angles tends to interfere with attitude (translational acceleration) control. In the absence of definitive measures, it is hypothesized that in this maneuver the pilot directs his view 6° to 10° below the horizontal while roughly positioning his aircraft. Nearer touchdown, the landing surface, which is much closer to the aircraft (30° to 50° down), must be viewed foveally, at least intermittently, for precise positioning. Referring to Fig. 3a, it is seen that such a scanning procedure in the aircraft, from far- to near-field, can be conducted in an uninterrupted scene, with the middle-distance field (from 15° to 25° down) always in either foveal or near-peripheral view. In contrast, the same angular scan in the VMS, from the forward window to the lower-right window, has nearly a 20° scene interruption. Cues from the middle-distance field are essentially absent. This absence may be a serious detriment to visual perception of aircraft motion. To obtain precise positioning information from the lower window, it is necessary to forego any far- or middle-distance cues to fixate momentarily at a highly depressed viewing angle. In the absence of associated peripheral middle-distance information, any perspective dynamics presented in the lower picture may lose much of their value. At the deceleration attitude (Fig. 4b), all meaningful information appears isolated in the lower window. In comparison with the view from the OH-58, it can be seen that there has been a severe diminution of visual information.

The VMS window arrangement is not the result of serious study of pilot-viewing requirements; instead, it is the result of concessions to the hardware geometry problems inherent in the mirror-beam-splitter collimators used to present the scenes. A window arrangement that will be available in the very near future will combine three of the windows in the joined configuration illustrated in Fig. 5. This total scene preserves continuity from the horizon to the nearest point-of-regard, which is depressed nearly 45°. The configuration shown, being symmetrical, is most appropriate to a single-place or two-place (tandem) aircraft, but the attributed virtues would still be realized if the left window were raised in simulation of a side-by-side cockpit. The field of view that will be available to the VMS complex in 1987 is shown in Fig. 6. Three edge-matched 40° by 60° scenes, generated by a Rediffusion CT5A system, will be projected inside a 6-m-diam dome. In addition to the symmetrical location shown, the total field may be displaced vertically and laterally, and eventually may be head-position slaved.

Scene Detail

A real-world runway scene (Fig. 7a) is offered for comparison with a simulated version in the VMS (Fig. 7b). In the flight photograph, the wealth of detail and contrasts is limited only by photographic resolution, whether in the near-field or in the far-field. In the computer-generated scene, there is no additional detail to discover, no finer textures to be seen than are apparent in the far-field 1,000 ft away. Detail that was quite acceptable at a distance becomes inadequate to define the surface at close range. The illustrated scene does not use the full capability of the generating system. A more recently modeled runway has at least twice the density of detail, but increases measured by orders of magnitude are required. An example of the significance of low scene-detail density is seen in the lower window (Fig. 7b). The threshold stripes seen in this view represent one of the finer levels of detail in the total scene, but no cues of fore-and-aft motion are available. The scene of the approach to a ship (Fig. 5a) might be assessed as very adequate for that phase of the landing maneuver, but near touchdown (Fig. 5b), there is negligible definition of the deck surface in the near-field. It has taken a long time for those working in the simulation field to recognize the magnitude of the visual-cueing diminution

that is being incurred in this this low-hover situation. The pilot must compensate for the loss of near-field detail by concentrating on the more distant perspective, thereby suffering a loss in his perception of the low translational rates typical of the precision hover maneuver. In the VMS window arrangements used to date, this compensation is made difficult by the vertical separation of the viewing areas.

Density of scene detail, or "spatial frequency," in visual simulation has been a subject of attention for some time, but primarily in regard to low-altitude, high-speed flight and other tactical maneuvers. The literature contains suggestions for acceptable minimums of spatial frequency (visible contrasts per degree of visual field) that vary from 0.05 to 3. (The deck surface represented in Fig. 5b might be assigned the value of 0.1.) For high-quality simulation of the hovering task, it is probable that values considerably less than 3 will suffice; and considering the cost of providing detail and texture in computer-generated scenes, experimental determination of the relationship between spatial frequency and simulation fidelity for critical research and training maneuvers should be given strong encouragement. Flight tests in which means to degrade the density of detail in the real visual scene were used, have demonstrated the detrimental effects of reduced scene detail, but the validity of extrapolating those results to computer-generated scenes can still be questioned at the present state of development of the technique. These experiments are discussed in Ref. 5.

This discussion of scene-detail limitations is based on the CGI system at Ames and others of its generation. Recently marketed systems have greater capacity for detail and can provide "texturing" of selected surfaces. It is hoped that these capabilities will be put to use immediately in pursuit of answers to the question of minimum scene-detail requirements.

Visual Time Delays

Computer graphics scene-generation systems require a finite interval in which to compute the scene elements. The total delay in the simulated scene, which can also include elements introduced by various simulator-system interfaces, can be an important fidelity issue. This delay, added to that in the aircraft dynamics computation, must be considered, especially when aircraft-control modes exhibit high sensitivity and low damping. This time delay, assessed to be about 100 msec in the VMS, has yet to be firmly identified as a major problem in helicopter simulations, but it has been suspected in several cases in which high-frequency dynamic instabilities seemed exaggerated. As noted previously, this was seen in the XV-15 simulation. VMS tests of a linear lead-lag time-delay compensation method are reported in Ref. 6. A nonlinear delay-compensation method, currently being evaluated, is described in Ref. 7.

COCKPIT MOTION FIDELITY

As was seen in the comparison of fields of view of the simulator and in flight, the relationship of simulator cockpit motion to that of the aircraft can be explicitly defined; for motion, that relationship is described by the drive logic and by the dynamic performance of the motion system. Beyond these measures, the similarities between the two cueing modes ends. A list of measures is required to describe fully the contents of the visual scene; motion needs no further description. The visual scene defines the important elements of the pilot's tasks; cockpit motion is an adjunct, not normally a requirement for completing a simulated flight task. Intelligently configured simulator cockpit motion, even of very limited amplitude, most often improves the subjective fidelity assessments (and emphasis must be placed on "intelligently configured"). Unfortunately, explicit definitions of "valuable" motion fidelity, for specific research or training objectives, remain for the most part undetermined. In the following paragraphs, the relationships between aircraft and VMS motions are described, and in the following section some experiments aimed at defining the contribution of cockpit vertical motion fidelity are discussed.

The VMS Motion Logic, or "Washout"

The VMS cockpit motion system has an exceptionally large excursion capability in its two translational modes, but the approach to its utilization is similar to that used in much smaller motion systems. The computed motions of the modeled aircraft cockpit are high-pass filtered, and sometimes directly attenuated, in order to be accommodated by the simulator motion system. Though virtues may remain to be demonstrated in the use of nonlinear filters, for reasons of simplicity and operational flexibility the VMS constraint logic, within "hard" logic defined by acceleration, velocity, and position limits of the machine, is basically linear. Rotational and linear accelerations computed for the cockpit are modified for representation in the simulator by the following general relationship:

$$\frac{\text{simulator acceleration}}{\text{aircraft acceleration}} = \frac{GS^2}{S^2 + 1.4\omega S + \omega^2}$$

where ω is the characteristic frequency of the high-pass filter, S is the Laplace operator, and G is the high-frequency gain.

The motion-constraint logic is shown in some detail in Fig. 8, with supporting definitions given in Table 2. Body-axis rotational rates are transformed (approximately) to simulator coordinates, and pilot-sensed linear accelerations are manipulated to define the six primary inputs to the motion-constraint logic. (The VMS is usually considered to be a five-degree-of-freedom system, but a very limited sixth degree can be realized by driving the six-actuator hydraulic system in a linear mode.) The cab can be tilted to provide low-frequency and steady-state representations of longitudinal and lateral

accelerations. What might appear to be awkward and imprecise aspects of this motion-logic implementation exist primarily for reasons of operational flexibility, simplicity, and the desire to accommodate acceleration, velocity, and position-limiting logic within the high-pass filters associated with the two large-amplitude linear drives. All of the gains (the G terms) and the filter frequencies are readily accessible variables, and are set to optimize the motion "recovery" for the particular task being simulated. Two sets of these variables (designated F and S versions) are defined in the motion-logic program; thus, a simulated task that comprises both a segment of large-amplitude maneuvering at high speed and a segment of low-amplitude, maneuvering at low speed can be accommodated by relating the variable sets to specific speed regimes and interpolating for speeds in between these ranges. Example sets of gain and frequency values suitable for a speed range from hover to cruise flight, involving typical handling-qualities assessment maneuvers, are presented in Table 2.

Fidelity of Vertical Motion

The experiments discussed in the following section deal almost entirely with height-control tasks. Only the fidelity of the vertical motion mode of the VMS is discussed in detail. Being essentially uncoupled with other drive modes, simulator vertical acceleration can be completely described by the basic second-order washout transfer function together with a transfer function approximating the frequency response of the electrical vertical drive system. Together, they define the relation

$$\frac{\text{simulator acceleration}}{\text{aircraft acceleration}} = \frac{GZS^2}{S^2 + 1.4\omega_z S + \omega_z^2} \frac{12^2}{S^2 + 9.6S + 12^2}$$

The gain and phase variations with frequency represented by this combination of linear transfer functions, for three values of ω_z , are illustrated in Fig. 9. The values of ω_z were used as test points in the height-control experiments discussed later. In the cases shown, GZ was held at unity. Of course, greater constraint of the simulator motion is effected by increasing values of ω_z and decreasing GZ. The lowest value of ω_z shown, 0.2, is commonly used in the VMS during simulation of hover tasks near the ground or landing pad. The value of 0.5 is used, often with a reduction in GZ, to accommodate the maneuvers of up-and-away flight. The highest value is an example of the constraint that might be required in a typical training simulator motion system, again with some reduction in GZ.

If it is somewhat arbitrarily assumed that motion phase distortion up to 20° (lead or lag) is representative of "high fidelity" motion, it is seen that for $\omega_z = 0.2$, a frequency range from 0.7 to 5.0 rad/sec is so described. This constitutes a major portion of the short-period maneuvering frequency range. At $\omega_z = 0.5$, the band of fidelity is constrained to frequencies above 1.5 rad/sec, thus still including important maneuver frequencies. The increase of ω_z to 1.25 results in severe phase lead throughout most of the normal maneuvering range. As in any frequency-related motion-constraint system, a band of highly distorted motion about the characteristic frequency must be tolerated.

VERTICAL MOTION-CUE EXPERIMENTS

Effects of Motion-Cue Fidelity on Handling-Qualities Assessments

In conjunction with a general fidelity assessment of the XV-15 Tilt Rotor Aircraft simulation at Ames, a brief experiment was conducted to determine the effects of vertical motion on pilot assessments of height-control handling qualities. The test conditions consisted of a matrix of three values of ω_z and variations in gain and delays of the aircraft response to collective-control inputs. The pilot task was a series of NOE maneuvers, including terrain-following and a bob-up to visual contact with a target. Four pilots were requested to give Cooper-Harper (Ref. 8) pilot-opinion ratings for each combination of aircraft and motion in a blind series of exposures. The results, averaged for the four pilots, are presented in Fig. 10. It is seen that the assessment of the unmodified aircraft (circle symbols), considered to have good response characteristics, was affected only slightly by the reduction in motion cues. However, degradations of the control system that added less than one and one half rating numbers with high-fidelity motion resulted in nearly twice that variation when motion was tightly constrained. Assessments were consistent across the pilot evaluators, as indicated by the modest range of ratings for each condition (Fig. 10). Spot evaluations with no vertical motion at all produced ratings similar to those for the most constrained motion. It was apparent that visual-motion discrepancies were not intellectually considered in the course of the tests; control difficulties were always attributed to poor collective response and to "reduced heave damping."

Effects on Pilot Response in Height-Control Tasks

Subsequent to the XV-15 handling-qualities assessments, a variety of height-control tasks were mechanized in the VMS with the objective of determining the effects of vertical-motion-cue fidelity on pilot-response characteristics and task performance.

Vehicle simulation - The simulation of a very simple hovering vehicle was mechanized for these experiments. It included no aerodynamic forces of significance, other than vertical rate damping, at hovering translational velocities. Moments and vertical forces resulting from controller inputs and rate damping were completely uncoupled. Vehicle derivatives and controller characteristics are listed in Table 3 for two vehicle configurations intended to represent good and slightly degraded vertical response. For most tests, the pilot's station was located at the center of gravity of the vehicle. The lifting force acted

through the center of gravity normal to the aircraft's longitudinal and lateral reference axes. Attitude control was effected with conventional stick and rudder pedals. Total stick deflection, longitudinally and laterally, was approximately 23 cm, with force gradients of 0.3 kg/cm. Vertical control employed a left-hand "collective" level configured for a specific aircraft development program. It was approximately 30 cm in length from grip top to its rotation point. Full travel of the lever was from horizontal (no lift) to 45° up (maximum lift). In steady hover, the lever was elevated about 30°. The controller employed light friction forces and no force-deflection gradient.

Tasks and data collection - Two tasks were presented in the initial tests. In the first, using a visual-scene representation of a hovering aircraft as a height reference, the pilot attempted to hold altitude against a pseudorandom vertical-acceleration disturbance imposed on his own aircraft. The disturbance was effected by adding the sum-of-sines function defined in Table 3 to the pilot's collective input signal. The forward-window scene during this task is shown in Fig. 11a. For the second task, the "target" aircraft, instead of the pilot's aircraft, was disturbed vertically by a similar sum-of-sines function, and the pilot maneuvered to maintain a fixed relative position. Further exploration of the visual-motion-cue relationship was conducted in a height-holding task, again against disturbances of the pilot's own aircraft, at various altitudes near the end of a conventional runway and in the absence of any other height references. The front-window scene for this task is illustrated in the photograph of Fig. 11b. In all of these tasks, the pilot was asked to attempt to hold a fixed position laterally and longitudinally. In each run, 85 sec of pilot performance was recorded after a 20-sec warm-up period.

All pertinent vehicle states and inputs were recorded, together with position errors and error-rates. An on-line dynamics analysis program was employed to produce a "pilot describing function," a linear representation of pilot-input gain and phase in response to aircraft height-error rate. These data were combined with the vehicle vertical-rate response to pilot input to define the open-loop characteristics of the tasks. The frequency at which open-loop gain approaches unity, the "crossover frequency," is considered a measure of the control bandwidth being exercised by the pilot, and the "phase margin" (phase + 180°) an indication of the level of stability being experienced. The effects of vertical-motion fidelity on these measures is the primary subject of the following discussions.

Results and discussion - Example open-loop characteristics documented for one pilot-and-aircraft combination in the tasks of height-holding with respect to another aircraft, for two levels of cockpit vertical-motion fidelity, are shown in Fig. 12. The data of Fig. 12a represent performance in the task of maintaining position relative to a stationary target against a pseudorandom vertical acceleration disturbance with components between 0.5 and 5.0 rad/sec. A crossover frequency of over 3 rad/sec was demonstrated, which might be considered a high value for height regulation. The pilot was exercising a maximum level of aggressiveness, as indicated by the phase margin at crossover of about 20°. In this case, the visually perceived height errors are the second integration of the computed cockpit acceleration. For the case of high motion fidelity ($\omega_z = 0.2$), this acceleration is sensed by the pilot with minimum distortion, providing him valid lead information on the height and height-rate errors he will perceive visually. The slope of the amplitude-ratio variation with frequency, for the range of frequencies shown, approximates that of the aircraft vertical-rate response to collective-control input, indicating that the pilot gain response relative to vertical rate was essentially constant. This was generally true for all of the pilots and tasks in these experiments.

With the highly constrained motion ($\omega_z = 1.25$), good correlation of visually perceived rates and simulator acceleration is present only at frequencies above 2.5 rad/sec. This reduction in motion cues results in a decrease of open-loop amplitude ratio (reflecting the same drop in pilot gain) of more than 3 dB, resulting in a crossover frequency of slightly more than 2 rad/sec. Again the pilot was operating on the edge of instability.

For the task of Fig. 12b, holding position relative to a randomly moving target, the variation in cockpit motion fidelity shows a different result. Pilot gain in both cases of motion fidelity is low, and the crossover frequencies for both conditions of motion are about 1.7 rad/sec. However, a marked difference is seen in the phase measured between 1 and 2 rad/sec. The phase lag of pilot response is reduced more than 30° by the increase in motion fidelity, with an increase of stability of control that is obvious to the pilot. It is this case that is most comparable to the handling-qualities evaluation task discussed in the previous section, where no disturbances were imposed on the pilot's aircraft. The higher-frequency components of the target-acceleration disturbance produce quite small rates and displacements that at the 50-m distance are not easily perceived visually. Perhaps this tends to inhibit the control bandwidth exercised by the pilot.

Crossover characteristics for the same pilot and tasks, with both aircraft configurations, are summarized in Fig. 13. The introduction of data for $\omega_z = 0.5$ reveals a systematic reduction in crossover frequency for the disturbance task and in phase margin for the following task, with increase in ω_z . As might be expected, the more lagged response of the second aircraft configuration produced lower crossover frequencies, but the phase-margin variation with motion fidelity was not significantly changed. Subjectively, this configuration seems more vulnerable to motion-cue degradation than configuration 1, but there is no obvious indication of this in the data.

Data obtained in the task of holding altitude over a runway are summarized in Fig. 14. Crossover frequencies and phase margins are presented for three pilots and for conditions of full cockpit motion (no washout) and no motion at all. To be noted first is the large variation in pilot aggressiveness as indicated by their general levels of crossover frequencies and phase margins (pilot 1 produced the data of

Figs. 12 and 13). This spread in pilot behavior was observed in all phases of the experiments. Across the performances, however, it can be seen that the addition of cockpit motion increased crossover frequencies by about 50%. The reduction in height and height-rate visual cueing introduced by increasing the altitude from 20 to 100 ft resulted in reductions in crossover frequency, more noted for the motion-on case than in the fixed-cockpit mode. Considering the no-motion case, the data indicate that visual perception of the very modest vertical rates seen in these experiments was still quite good at 100 ft. Further analyses of these and additional available data might provide a more complete understanding of the relative roles of visual and motion cues in this type of near-the-terrain task.

The task of holding altitude at 20 ft included visual cues equal to or better than those seen in the task of holding altitude relative to the other aircraft; the tasks might be considered very similar. In comparing the data for pilot 1 of Fig. 14 with those for aircraft configuration 1 in Fig. 13, it is seen that the variation in crossover parameters with reduction of motion from full to none is about equalled by the variations induced by changing ω_z from 0.2 to 1.25.

No performance data, in terms of rms height error or height-rate error, are shown here, though they were collected in these tests. The performances were not grossly affected by the experimental variables, but what differences could be observed tended to confirm the expectations generated by changes in crossover frequency and phase margin. Further analysis of these data will include more emphasis on performance measures.

A very small amount of data was obtained in examination of the effects of simple gain reductions in the motion. It was indicated that for $\omega_z < 0.5$, reduction in motion gain to 0.5 produces modest decreases in crossover frequency or phase margin; thus it appears to be a legitimate approach to the efficient use of a cockpit-motion system. The general conclusion from all these data is that for reasonably full fidelity in simulation of height-control maneuvers, vertical-motion-cue phase fidelity is required down to frequencies of 1-1.5 rad/sec. Even with large-motion systems, this fidelity can be produced only in very constrained flight tasks; thus, we are left with the requirement to account for the effects of reduced vertical-motion-cue fidelity in the general use of research and training helicopter simulators. It is conceivable that further modeling of pilot response to motion cues will provide us with the means to implement rational modifications in the dynamic response of the simulated vehicle to compensate for motion-cue deficiencies.

This emphasis on vertical motion was the result of the unique opportunity afforded by the VMS and the rationalization that in many cases the linear motions of the pilot's task are not supported by the strong visual stimuli experienced in rotational motions. It was predicted that a special sensitivity to absence of linear motion cues would be demonstrated. These data to some degree support that prediction, but further experiments are required to examine the effects of motion fidelity in the other motion modes, and especially in the combined linear and rotational modes associated with cockpit locations well off the rotational axes. On the basis of the cockpit motion experience at Ames, some general observations can be offered: (1) phase distortion in vertical-motion cues resulting from increases in ω_z , though it does eliminate effective maneuvering frequency cues, seldom produces strong evidence of visual-motion cue conflict; and (2) phase distortion in cockpit rotations can produce severely disturbing effects at second-order washout filter frequencies above about 0.7 rad/sec, if maneuver accelerations are substantial and motion gains are near unity; no motion at all is much preferred. The vertigo experienced is presumed to arise from the conflicting strong visual and motion stimuli.

CONCLUDING REMARKS

Extensive recent experience with helicopter simulation in the Ames VMS facility indicates that even given a wide field-of-view, computer-generated visual-simulation system and uniquely large-amplitude cockpit motion, the desired levels of fidelity in simulation of important research flight tasks is not obtained. Considerations of the characteristics and capabilities of the visual system lead to the conclusion that the primary limitations on fidelity stem from the inability of the visual system to provide adequate texture and detail in renditions of the near-field scenes in hover and landing. This constraint is compounded by nonoptimum distribution of the four viewing fields. Experiments to define adequate field-of-view and, especially, the near-field spatial frequency of detail, are needed. Considering the cost of present visual-simulation systems, imaginative efforts should be made to answer these questions. Unfortunately, the present approach of the simulation community appears to be one of waiting for the next more expensive device to be developed, optimistically assuming that its capabilities will make the present questions academic.

The vertical-motion experiments reported here disclose that high-fidelity motion cues make a significant contribution in the performance of height-control tasks. Further expansion and analysis of the data may lead to improved test procedures and to better interpretation of results in simulations that do not include vertical-motion cues at maneuvering frequencies. The real objective of further motion-cueing experiments will be, of course, the generation of enough information to support the development of practical pilot-response models incorporating motion-sensing modes that are realistically varied in accordance with the associated visual cues.

REFERENCES

1. Bray, Ronald S.: Helicopter Simulation Technology: An Ames Research Center Perspective. NASA JF-0219, 1982, pp. 199-208.
2. Brunchill, G. B.: Use of Simulation in the XV-15 Program. AGARD FMP Symposium on Flight Simulation, Cambridge, U.K., 1985.
3. Clement, Warren F.; Cleveland, William B.; and Key, David L.: Assessments of Simulation Fidelity Using Measurements of Pilot Technique in Flight. AGARD Conference Proceedings No. 359, Monterey, Calif., 1984.
4. Paulk, C. H., Jr.; Astill, D. G.; and Donley, S. T.: Simulation Evaluation of the OH-23 Helicopter in a Shipboard Environment Using the Interchangeable Cab System. NASA TM-84357, 1983.
5. Hoh, Roger H.: Investigation of Outside Visual Cues Required for Low Speed and Hover. AIAA Paper 85-1808-CP, Snowmass, Colo., 1985.
6. Crane, D. F.: Compensation for Time-Delay in Flight Simulator Visual Displays. Proceedings of the AIAA Flight Simulation Technologies Conference, Niagara Falls, N.Y., 1983.
7. McFarland, R. E.: CGI Delay Compensation. NASA TM-86703, 1985.
8. Cooper, George E.; and Harper, Robert P., Jr.: The Use of Pilot Rating in the Evaluation of Aircraft Handling Qualities. NASA TN D-5153, 1969.

TABLE 1. VMS VISUAL- AND MOTION-SYSTEM SPECIFICATIONS

DIG I visual simulator			
Full daylight scene capability			
Four channels (windows)			
1024-line raster format			
30-Hz update (non-interlaced)			
8,000 polygons			
256 edge crossings per scan line			
Motion System of VMS			
Motion	Total displacement	Velocity	Acceleration
Lateral	12.0 m	2.5 m/sec	4.5 m/sec ²
Vertical	17.0 m	5.0 m/sec	7.0 m/sec ²
Roll	40°	20°/sec	60°/sec ²
Pitch	40°	20°/sec	60°/sec ²
Yaw	40°	20°/sec	60°/sec ²

TABLE 2. DEFINITIONS OF VMS MOTION LOGIC VARIABLES (see Fig. 8)

p_b	aircraft body-axis roll rate, rad/sec
q_b	aircraft body-axis pitch rate, rad/sec
r_b	aircraft body-axis yaw rate, rad/sec
a_{xp}	pilot-perceived longitudinal acceleration, m/sec ²
a_{yp}	pilot-perceived lateral acceleration, m/sec ²
a_{zp}	pilot-perceived vertical acceleration, m/sec ²
g	acceleration due to gravity, m/sec ²
ϕ	roll attitude, rad
θ	pitch attitude, rad
ψ	yaw angle, rad
θ_{tx}	pitch tilt to simulate a_{xp} , rad
θ_{ty}	roll tilt to simulate a_{yp} , rad
Y_ϕ	simulator lateral acceleration for roll coordination, m/sec ²

Subscripts:

a aircraft
s simulator

Motion logic variables:		Example values	
		Low speed	High speed
GP	roll gain	0.7	0.3
GQ	pitch gain	0.5	0.5
GR	yaw gain	0.5	0.7
GX	longitudinal gain	0.5	0.5
GY	lateral gain	1.0	0.6
GZ	vertical gain	1.0	0.5
ω_p	roll washout frequency, rad/sec	0.5	0.7
ω_q	pitch washout frequency, rad/sec	0.5	0.5
ω_r	yaw washout frequency, rad/sec	0.4	0.6
ω_x	longitudinal washout frequency, rad/sec	3.0	3.0
ω_y	lateral washout frequency, rad/sec	0.4	0.5
ω_z	vertical washout frequency, rad/sec	0.2	0.6
GQX	pitch-tilt gain	0.6	0.6
GPY	roll-tilt gain	0.6	0.6
GXC	lateral-roll coordination ratio	1.0	1.0
ω_{qr}	pitch-tilt lag-filter frequency, rad/sec	2.0	2.0
ω_{pr}	roll-tilt lag-filter frequency, rad/sec	3.0	3.0

TABLE 3. HEIGHT-CONTROL TEST PARAMETERS

Vehicle characteristics ^a		
Roll acceleration per unit controller deflection, rad/sec ²	1.5	
Pitch acceleration per unit controller deflection, rad/sec ²	1.5	
Yaw acceleration per unit controller deflection, rad/sec ²	1.5	
Vertical acceleration per unit controller deflection, m/sec ²	14.0	
Roll acceleration due to roll rate, 1/sec	-2.0	
Pitch acceleration due to pitch rate, 1/sec	-2.0	
Yaw acceleration due to yaw rate, 1/sec	-2.0	
	Conf. 1	Conf. 2
Vertical acceleration due to vertical rate, 1/sec	-0.3	-0.1
Collective control output lag, sec	0.1	0.25
Sum-of-sines disturbance (equivalent collective deflection)		
Frequency, rad/sec	Amplitude	
0.58	-0.035	
0.87	0.050	
1.31	-0.075	
1.75	0.075	
2.62	-0.050	
3.49	0.030	
5.24	-0.017	

^aAll accelerations are in body axes; unit deflections for the altitude controllers are full deflections from center (trim); unit deflection for the collective controller is from full down to full up.

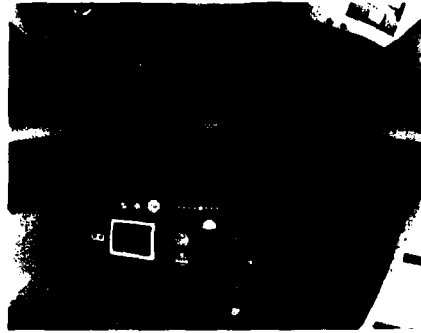

Fig. 1. The interior of one of four interchangeable cabs available for use with the Ames Vertical Motion Simulator (VMS).

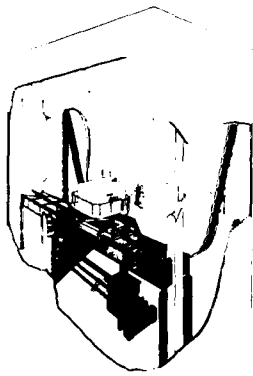
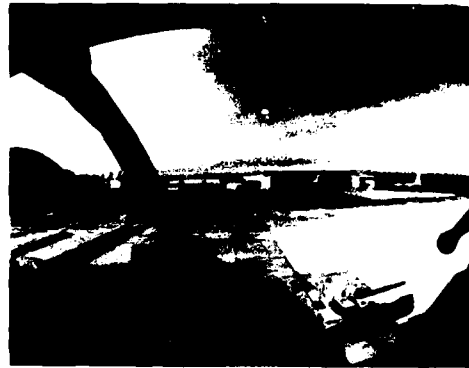

Fig. 2. VMS with an interchangeable cab installed.



(a) Hover.



(b) Deceleration (15° nose up).

Fig. 3. Representation of the forward view from an OH-58 helicopter.



(a) Hover.



(b) Deceleration (15° nose up).

Fig. 4. Ramp scene viewed through a representation of the simulator's fields of view.



(a) Approach.

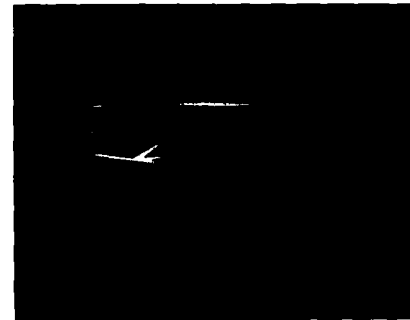

(b) Near touchdown.

Fig. 5. Scenes of approach to a shipboard landing as presented by an arrangement of three joined collimators.



Fig. 6. Ramp scene presented in the field to be available with three edge-matched projections (each projection 40° by 60°).



(a) Flight (OH-58).

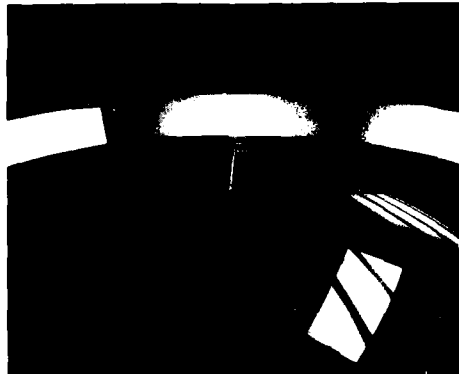

(b) VMS.

Fig. 7. Comparison of scene detail present in flight and in the VMS.

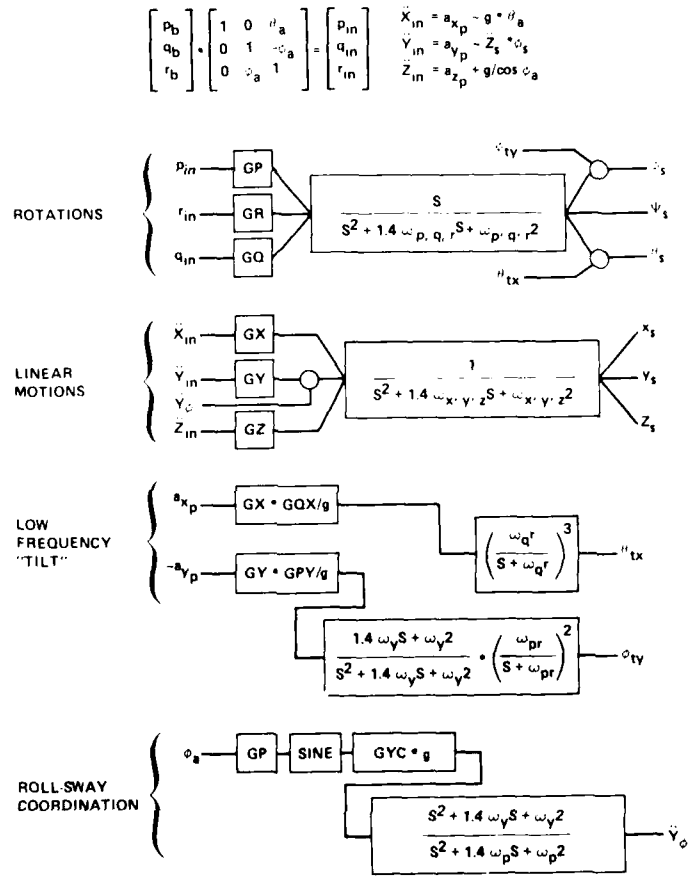

Fig. 8. Elements of the VMS motion-constraint, or washout logic.

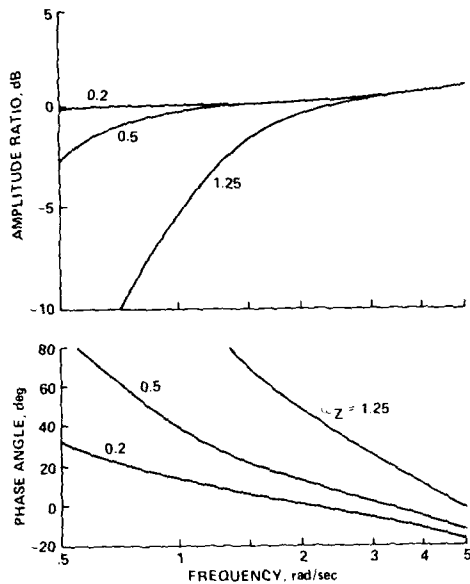
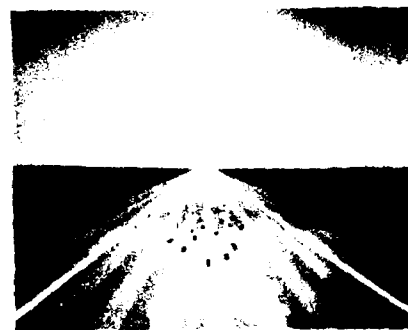

Fig. 9. Amplitude and phase of VMS vertical-acceleration response with respect to computed cockpit vertical acceleration for several values of washout characteristic frequency.



(a) Height-reference aircraft.



(b) Altitude-hold runway scene.

Fig. 11. Forward-window views as seen in the height-control experiments.

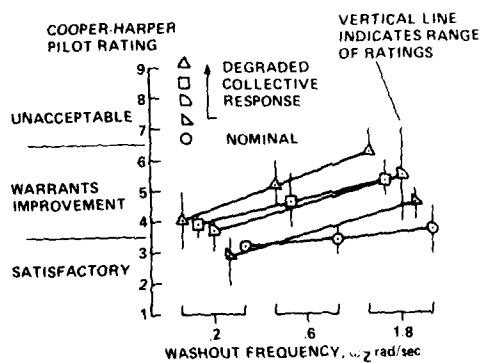

Fig. 10. Variation of pilot opinion ratings of vehicle vertical-response handling qualities with vertical-motion fidelity.

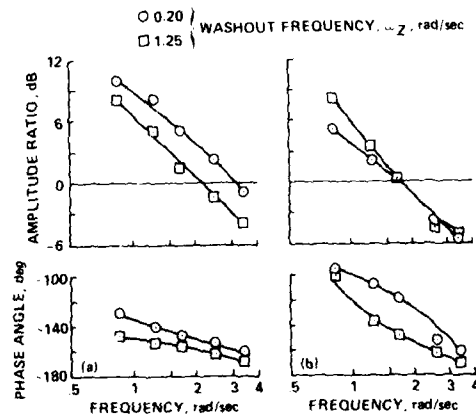

Fig. 12. Effects of cockpit-motion fidelity on open-loop gain and phase variations with frequency for two vertical-position-holding tasks. (a) Stabilizing against a disturbance. (b) Tracking a moving target.

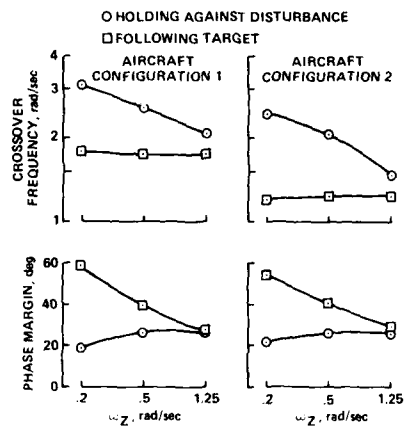

Fig. 13. Variations of crossover frequency and phase margin seen in altitude-control tasks with variations in vertical-motion fidelity and aircraft-response characteristics.

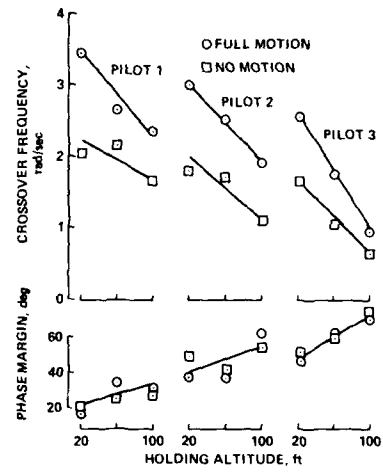

Fig. 14. Effects of vertical motion and altitude on crossover frequency and phase margin measured for three pilots in the simulated task of holding altitude over a runway against a vertical disturbance.

VISUAL DISPLAY RESEARCH TOOL

by

P.M.Murray and B.Barber
Rediffusion Simulation Ltd
Gatwick Road
Crawley, W.Sussex RH10 2RI.
United Kingdom

1.0 VDRT PROGRAMME

1.1 Overall Objective

The simulation of the view seen by the pilot through the cockpit canopy where high detail over a wide field is required, as in low-level flight, navigation and target acquisition for example, remains a difficult and expensive problem.

This requirement may be partially fulfilled by multiple display systems of from five to eight channels, each covering about 70° and giving a resolution of 6-9 arc minutes per pixel at a cost in the region of \$20m. To consider achieving 2 arc minutes per pixel over the complete field of regard available to pilot, which is closer to the real requirements, merely by adding C.G.I. channels and display devices is highly impracticable on grounds of acquisition cost alone, without regard to maintenance problems and running cost.

The rational alternative to generating and displaying imagery over the whole field required by the pilot is to take advantage of the limitations of human visual perception. This can be achieved by confining the displayed image to the pilots area of interest at any instant, and also arranging to concentrate the available scene detail over a small area corresponding to his central vision and providing only low resolution elsewhere. The overall visual system requirement is therefore greatly reduced, as is the system cost, but without loss of performance.

The Visual Display Research Tool (VDRT) is a new concept in visual displays which utilises this 'area of interest' approach by matching its display parameters to those of the human eye.

Two fields of view are employed, a wide-angle field corresponding to the peripheral area and an area of interest field inset at its centre. The combined field is coupled to head and eye movements such that the direction of gaze is followed and a detailed scene is apparent over the whole field of regard at all times.

The specific design chosen for VDRT is based on helmet mounted projection of two full colour rasters onto the interior surface of a spherical dome surrounding the cockpit.

1.2 Rationale for VDRT approach i.e. Background

Rediffusion Simulation Limited started investigating area of interest (AOI) displays in the days when imagery was derived from modelboards using CCTV. The initial work resulted, in 1974, in a design (1) for a helmet mounted projector having a 32° by 24° instantaneous field of view centred on the pilot's head pointing direction. Freedom to move the head was achieved by having a light valve projector, fixed in the cockpit behind the pilot, projecting an image down a jointed optical relay assembly which allowed motion in the yaw pitch and roll axes and which was fitted with angle sensors to provide head orientation angle information to drive the optical probe at the modelboard.

The introduction of computer generated imagery removed the limitation of a single channel limited field of view display imposed by the television camera:probe assembly and opened up the opportunities to explore more exotic approaches providing much larger fields of view. The provision of wide fields of view of uniform high resolution imagery is expensive and may not be necessary if the resolution of the image is tailored to match that of the eye, but this can require eye tracking to keep the high resolution imagery centred on the fovea.

Rediffusion had gained experience of using lasers to produce high resolution wide angle colour imagery (2) and used this knowledge to develop the concept of a helmet mounted projector (3,4) in which the lasers and polygon line scanner were mounted on the cockpit structure behind the pilot and the line scan was relayed to the pilot's helmet via a fibre optic link, with a projection lens and a frame scanner mounted on the pilot's helmet. This is illustrated in Figure 1, taken from U.K. patent number 2041562, which also shows several other interesting features.

The screen material selected was Scotchlite (5), a material designed for front projection screens and reflex projection composite photography, which has a very high gain (about 1600) for a retro-reflecting

beam, with a very rapid reduction in gain with divergence from retro-reflectivity such that the gain is only about 100 with 10 divergence. Thus, as shown in Figure 1, two images can be produced on the screen separated by the interocular distance such that each eye only sees one image because the viewing angle to the other eye image is sufficiently different from the projection angle to reduce the gain of that image to a very low level. The attenuation of the other eye image can be increased by moving the screen nearer the pilot. It is therefore possible to display a pair of images for a pilot, which can be an identical pair to give the impression of a collimated display, or a stereoscopic pair to give a three dimensional display. This is possible even with a screen near the pilot because focus is a weak range cue whereas convergence is a strong range cue.

Separating the line and frame scanners by a fibre optic link allows the relatively bulky high speed line scanner to be securely mounted to the simulator fuselage structure with a light frame scanner mounted on the pilot's helmet.

Each fibre array need only consist of an n by 1 array since only one scan line is transmitted at a time. Each fibre does, however, equate to a displayed pixel and, to achieve a near eye limited resolution picture would require about 6000 fibres which at the projection end must be fitted into the pilot's interocular distance, which if assumed to be 36mm, requires fibres of 6 micron outside diameter.

To minimise the weight on the helmet the projection optics was a sphere mounted above each eye with the fibre optic array arranged so as to transmit the beam from each fibre radially down towards the centre of the spherical lens. Although the resulting lens is a wide angle lens, by selecting the fibre indices each fibre would only transmit a narrow cone through the lens thus keeping the aberrations to a minimum.

For maximum screen gain the projector axis must be coincident with the viewing axis. In practice this means that a beam splitter must be placed in front of the pilot's eyes and this could conveniently also be the frame scanner. However, having an oscillating frame scanner directly in front of the pilot's eyes was not considered to be satisfactory due to effects such as glare caused by dust on the surface, and the fact the frame scanner would have to be semi-reflective resulting in a loss of gain, etc, so that it was decided to mount the frame scanner at the eyebrow position where it could be reflective, even though this position meant the effective screen gain was reduced due to the divergence between the projected and viewed beams.

The need for compensation for the cgi throughput delay in order to stabilise the image in space was recognised and a "throughput delay error compensation" box incorporated in the Figure.

This concept was developed further under contract from the Naval Training Equipment Center (6) and conceptual attempts made to incorporate a high resolution insert into a lower resolution surround so that an eye tracked visual system could be designed, but this is quite difficult with the simple helmet mounted optics then being considered.

The Advanced Simulation Concepts Laboratory of the Naval Training Equipment Center developed the concept of a helmet mounted projector further taking into consideration compatibility with the Visual Technology Research Simulator (VTRS) with which it would have to interface (7). The resulting design concept put more complicated optics on to the pilot's helmet, had only a single projector point for an image to be viewed by both eyes, and used the Scotchlite screen material at a lower than maximum but still useful gain. The advantage of using more complicated optics on the helmet is that two fields of view, one having a high resolution but narrow field of view and the other having a lower resolution but large field of view can be combined and eye tracked to produce a display with a resolution distribution about the gaze direction which approximates to the resolving power of the eye. In this case the fields of view and resolution were matched to the twin channel 1000 line image generation system installed on the VTRS.

This design concept was the subject of a competitive tender and a development contract for the Visual Display Research Tool was awarded to American Airlines Training Corporation (AATC) as Prime Contractor.s with Rediffusion Simulation Limited (RSL) being the principle subcontractor with responsibilities for design of the projector and control system, and for total system integration on site at the Naval Training Equipment Center, Orlando, Florida.

1.3 VDRT Development Programme

The Naval Training Equipment Center (NTEC) Florida, awarded the contract in October 1982 for the design and construction of a prototype system to be installed at the NTEC VTRS facility.

Other companies involved besides AATC and RSL are Polhemus Navigational Services, who are to provide the head and eye trackers, and General Electric, to apply modifications to the existing image generator.

Also available as government furnished equipment is a T-2c cockpit and flight computer, and a ten foot radius hemi-spherical screen.

The programme was scheduled over 36 months including the on-site installation and acceptance period.

Design and liaison between sub-contractors occupied the period through to end of 1983 followed generally by construction and integration of hardware during 1984.

All major sub-systems are now delivered to site following individual in factory test, and system integration is well advanced. Final testing and acceptance is expected to take place as originally planned in September and October this year.

2.0 SYSTEM DESCRIPTION

2.1 VDRT Configuration - Major Sub-System

The VDRT block diagram is shown in Figure 2. The Host Computer and cig system were part of the VTRS system. The VTRS system operated as a synchronous 60Hz system controlled by a master clock in the image generator and this feature has been retained in the VDRT with all the systems being synchronous and locked to the cig. Since the projection system is mounted on the pilot's helmet the instantaneous scan direction is a function of the pilot's instantaneous head orientation. It is therefore necessary to measure the pilot's head orientation with respect to the simulator fuselage and use these angles and angular rates to position the image at the correct orientation in space and to maintain this orientation if the pilot's head continues to rotate during the image display period during each TV field. Since the display seen by the pilot is a combination of a small high resolution patch in a larger low resolution field with the centre of the high resolution area centred on the direction of gaze, the angular orientation of the eye must be measured and this is achieved with the eye tracker. The Visual Processor is a mini computer which is incorporated so as to be able to combine the head and eye tracker outputs, which are in different time frames, and provides an input to the cig system which takes into account the latency of the head and eye tracker information and the cig throughput delay, and provides offset and rate signals to the galvanometers mounted in the helmet mounted projector so as to stabilise the image in space during each display field period. The Line Image Generator incorporates the three modulated colour beams for each field and presents them to the line scanner to produce the two line scans for the two displayed fields forming a composite display. The Fibre Optic Links comprise a pair of line arrays which relay the two line scans from the line image generator to the helmet mounted projector. The Helmet Mounted Projector is a complicated optical system containing provision for producing offsets in both the line scan direction and the frame scan direction, the two frame scans for the respective fields forming the display, a method of combining these two fields, and a folded inverted telescope to provide the magnification necessary to produce the wide field of view display and to put the projection point in the required place. The cig system produces the images for the two fields and incorporates the inverse of the distortion function of the optical system into the image so as to produce an undistorted image for the wearer of the helmet. These systems are described in more detail below.

2.2 Line Image Generator

The LIG, is the primary off-helmet optical system providing the following functions:-

- (1) Display illumination source - ie lasers,
- (2) Colour separation,
- (3) Display modulation,
- (4) Line scanning,
- (5) Line imaging.

Two 1 metre argon ion lasers are used, one to provide green and blue light (ie. 514 nanometers and 476/454 nanometers) and the other for pumping a dye laser to provide red light at 610 nanometers. Other types and configurations of lasers were considered but this approach was chosen for optimum flexibility and space utilisation.

Separation of blue and green lines using a dispersion prism allows the rejection of the intermediate blue/green lines which would otherwise reduce the contrast of the blue and green channels. A second identical prism recombines the short wavelength blues.

The red, green, and blue beams are each split into two with a polarising element, to allow full colour modulation of the two rasters.

Modulation is achieved with six acousto-optic transducers operating with a video bandwidth of 14MHz.

Scophony illumination is used in which the direction and angular speed of the acoustic waves in the modulators is exactly compensated by the angular speed imparted by the line scanner to the beam. This technique allows the illuminated length of the acoustic column in each modulator to be large compared with that occupied by one pixel. The power density within the crystal is therefore relatively low and there are also benefits for system resolution.

The red, green and blue beams for each raster are not actually combined to form a single white beam at any point in the LIG or in the system as a whole. The beams are instead focussed at separate points along the line scan. Colour registration is achieved by phase adjustment of the R.G.B. video, which is generally applied by shifting the a-o modulator across the beam in the direction of propagation of the acoustic waves.

The two sets of three colour beams from the modulators are focussed onto a single facet of the line scanner polygon as two spots separated by a few millimetres. The two line scans produced after reflection are then separated by 90° after the AOI beam is reflected at a flat mirror. The 24 faceted polygon produces a line rate of 30.69KHz at 76,700 rpm.

Two compound lens systems termed post-polygon optics, one for each line scan, produce a finely focussed, 10mm long line image, at the fibre terminations.

2.3 Fibre Optic Links - target specification and current status

The fibre optics provide the link between the line image generators and the helmet-mounted projector. In that they are required to transmit line images, only a ribbon rather than a full bundle can be used allowing each cable to be light and flexible as compared with the more usual type of imaging array.

The 10mm line image was chosen to avoid large diameter optics within the projector and as a consequence minimise helmet weight.

The use of a 1023 line raster and the target for system resolution dictated that 1000 fibres be used in each link demanding an individual fibre outside diameter of 10 microns.

As compared with a standard coherent fibre bundle this linear fibre array needs to be manufactured with greater precision and with a proportionally lower incidence of non-uniformities. Linearity and spacing of fibres should, ideally, not vary by more than 1-2 microns. Equally important is the transmission uniformity required in adjacent fibres and across the complete array.

Precise alignment with the line image in the LIG is achieved with a combination of fine movement of the fibre termination and adjustment of a cylindrical lens incorporated in the post polygon optical system. Similar but less critical alignment is carried out at the projector.

The useful life of the fibre optic links will be determined through in-service use of the equipment. A replacement fibre can however be fitted within a few hours.

The development of the fibre optics through several prototype units has so far produced generally well aligned fibres of fairly even spacing. Conversely the packing factor has tended to be 7 or 8% low and the incidence of 'grey' fibres has not yet reached an acceptable level. However, the overall transmission performance has been sufficient to allow assessments of display resolution and brightness to be made, with encouraging results.

A further three fibre optic units now available at NTEC are yet to be fully evaluated.

2.4 The Helmet-Mounted Projector

As outlined in the section giving rationale for the VDRT approach the purpose and function of the helmet-mounted projector is as follows :-

- (1) To allow the exit pupil to be placed very close to the axis of the pilot's eye allowing a high gain screen characteristic to be used for one or more

flight crew and to minimise off-axis distortion and de-focussing.

- (2) To minimize obscuration and shadowing by cockpit structure.
- (3) Through the use of galvanometer driven mirrors provide vertical scanning for rasters and both vertical and horizontal deflection of the display to accommodate eye movement and avoid smearing due to head motion within a frame scan period.
- (4) To optically combine the AOI and IFOV fields and project them from a common exit pupil.

The helmet-mounted projector is comprised of two units; the scan unit and the telescope. The scan unit mounts the output terminals of the fibre optics, contains three galvanometer driven mirrors for display off-setting and frame scanning and combines the two rasters onto coaxial beam paths.

The telescope is an optical relay with no moving parts. It receives collimated light from the scan unit, mounted on top of the helmet, and carries the light to an exit pupil, nominally 35mm above and 60mm forward of the centre of a line joining the pilot's eyes. The light is then projected forward to focus on the screen. In order to minimise weight distortion has not been corrected optically but has been computed and the inverse distortion function is applied within the cig system.

Light from the fibre optic ribbons passes through relay lenses on to separate mirrors mounted on a single drive shaft for production of identical line direction offsets by the line scan offset galvanometers. The AOI and IFOV line scans are separately collimated using beam splitters and spherical mirrors. The collimated IFOV beam then passes to the IFOV frame scan mirror which provides approximately 75% of the IFOV frame scan and directs the scanned beam on to the AOI frame scan mirror. The AOI collimated beam, which is broader than the IFOV beam, passes the IFOV scanner with little loss due to obstruction of the beam by the IFOV frame scan mirror to the AOI frame scan mirror which provides the remaining scan for the IFOV and all the scan for the AOI and also provides offset corrections in the frame scan direction to both beams.

The inertia of the relatively large AOI frame scan mirror dictates a scan flyback time of 2.5 milliseconds which restricts the number of active lines to 870 per frame.

The telescope has magnification of 2.6 which creates AOI and IFOV rasters of $27^\circ \times 24^\circ$ and $140^\circ \times 100^\circ$ respectively.

The mounting structure of the projectors is primarily of magnesium resulting in an overall weight of 4 pounds.

The projector is mounted on a light weight helmet shell to which is also attached the head tracking sensor and the illuminator and ccd array required for eye tracking.

2.5 Head Tracker

The head tracker is a commercially available electromagnetic head tracker which radiates a rotating field from a transmitter coil mounted behind the pilot, senses the radiation on a receiver coil mounted on the back of the helmet and then computes the orientation of the helmet. This is accomplished at field rate (60Hz). The sampling process takes about 9 milliseconds and the computation takes about 6 milliseconds. The resulting angles are input to the Visual Processor.

2.6 Eye Tracker

The eye tracker is based on a commercially available device which measures eye pointing direction by sensing the position of the illumination spot on the front surface of the pupil against the illuminated retina. The camera/illuminator assembly has been specially designed for this application so it can be mounted on the helmet. It is a conventional ccd array television camera mounted with an on axis illuminator which focusses a spot of light on to the pupil. The position of the image on the camera ccd array is a function of where the eye is looking; the television camera video is examined during one field, the angles are computed during the next field and the data is output at the beginning of the third field. The system is pipelined so it can operate synchronously at 60Hz but the eye position data has a latency of about 20 to 37 milliseconds depending on look angles. The eye angles are input to the Visual Processor.

2.7 CIG System

The cig system is the G.E. Compuscene previously used with the VTRS. It is a polygon modelled system with two 1000 line colour display channels and incorporates distortion correction to compensate for the inherent distortion of the wide angle projector system when the gaze angle is on axis. It also incorporates the blending functions necessary to fade out the edges of the central high resolution field and to create an inverse blanked area in the low resolution wide angle field so as to produce a composite image with a low resolution surround and a high resolution central region. The system operates at 60Hz field rate and has a computation delay of almost four fields before starting to output video.

2.8 The Visual Processor

The Visual Processor is a Gould SEL 32/27 Computer. It is programmed to iterate synchronously with the 60Hz master clock derived from the cig. The visual processor has as input the unfiltered head and eye orientation signals from the head and eye trackers. It applies suitable filters to these signal sets and derives angular rates. The head orientation and angular rate signals are used to predict head orientation after the cig computation delay of four fields and these values are passed to the host computer to be combined with the simulated aircraft Euler angles to provide the look angle inputs to the cig. Since the cig is a pipelined system this is done every field. The head orientation and angular rate immediately prior to video display is used to predict head orientation one field ahead and this value is compared with the no change previous prediction to compute line and frame offsets which are fed, together with the angular rates, to the offset mirrors in the Helmet Mounted Projector to stabilise the image in space. The direction of gaze, as derived from the eye tracker, is superimposed on the cig look angle and offset galvanometers to correctly position the high resolution AOI image in the established display.

SECTION 3 HUMAN FACTORS

3.1 Helmet Assembly

The helmet assembly consists of the helmet mounted projector assembly, the illuminator, detector and optics used for eye tracking, the head tracking sensor, the connecting cables and fibre optics cables, and a helmet shell.

The helmet shell, which is made of Kevlar, has been constructed to a standard aviation profile and has been sized to enable it to be fitted to aviators with head sizes within the 5th to the 95th percentile.

The helmet is not fitted with the usual protective padding but is fitted with a small number of adjustable pads to facilitate adjustment for individual pilots. Pads are fitted to the front and top of the inside of the helmet so as to position the exit pupil at the correct location with respect to the pilot's eyes. The chin strap is then adjusted to retain the helmet and an inflatable tube fitted to the sides and rear of the helmet inflated to provide closely fitting padding in these areas.

The total weight of the helmet, helmet mounted projector, cables, fibre optic links, communication equipment and padding is approximately 5.5 pounds, of which 2 pounds is offset by a tensorator.

3.2 Adjustment of ET to individuals

The eye tracker illuminator/camera assembly is mounted on slides so that a simple screw adjustment is all that is required to focus the illuminator on to the pupil.

3.3 Head and ET calibration

The head tracker is boresighted by aligning a cross projected on the optical axis i.e. centre of the AOI with zero offsets, on to a reference cross projected from a fixed slide projector mounted at the rear of the dome.

The eye tracker is then calibrated by looking at a sequence of projected points.

Head and eye tracker calibration should only take about one minute at the beginning of an exercise.

3.4 Saccadic Suppression

The system has been designed so that, even though the output portion of the projector is mounted on the pilot's head, the image is stabilised in space by eliminating the effects of the cig throughput delay on the spatial information. The AOI is part of this stabilised image but its location within the image is determined by the measured eye pointing direction which precedes the display by about 6 TV fields or 100 milliseconds. Thus it is possible to refixate the eye into a part of the display which is initially low resolution but which changes to high resolution in 100 milliseconds.

Two factors mitigate against this:-

- (i) Saccades are usually small enough to fall within the existing AOI boundary,
- (ii) Saccadic suppression allows the cig time to paint the correct resolution image.

In practice, preliminary tests conducted by engineers have shown that the time delay can be considerably increased without this effect being noticeable. This, however, needs to be confirmed under controlled conditions.

SECTION 4 EVALUATION

4.1 System Performance

As stated earlier the programme is currently in its on-site commissioning phase with system evaluation scheduled to begin in October 1985. No formal experimental data is therefore expected for at least several months from that date. However, some indications of performance have already arisen from the normal setting up and test procedures carried out in recent months.

The AOI and IFOV rasters have both been projected in full colour with the AOI correctly inset within the IFOV.

Limiting resolution is considered to be at present in the region of 2.7arc mins/pixel in the AOI and 13arc mins/pixel in the IFOV.

Brightness has not been measured but is expected to be well in excess of 10f1.

In dynamic mode using head attitude sensing, excellent image stability has been achieved by fine tuning the head position prediction algorithms. Image lag at 2Hz is now reduced to approximately one millisecond.

Eye attitude sensing is also operational but as yet has not been optimised for best response.

The fibre optic links currently being used include a relatively high incidence of 'grey' fibres which produce a vertical structure on the display which is significantly reducing image quality.

More uniform fibres are expected to be available for acceptance testing.

The helmet assembly has been worn for extended periods by a number of subjects including a U.S. Navy aviator. The slightly above average helmet weight of 5.5 lbs is not a great cause of concern.

5.0 CONCLUSIONS

The VDRT has been designed to meet the specified performance in a manner which allows a great deal of flexibility in system performance under software control. It should enable a lot of experimental results to be obtained on the performance and suitability of a head mounted eye tracker area of interest system as a training device.

REFERENCES

- 1 UK Patent No. 1,489,758
- 2 A continuous wide-angle visual system using scanned lasers. Mr. P.M. Murray and Mr. B. Barber. Image II, 1981.
- 3 UK Patent No. 2,041,563 b.
- 4 UK Patent No. 2,041,562 B.
- 5 Scotchlite Product Bulletin. 3M Company.

6. Scanned Laser final report specification and modification supplement. Realtime Simulation Limited, NAVTRAEQUIPCEN Contract N61339--7C-0001, November 1979.
7. Helmet Mounted Laser Projector, Mr. D. Breglia, Dr. A.M. Spooner, and Mr. D. Lohr. Image 11, 1981.

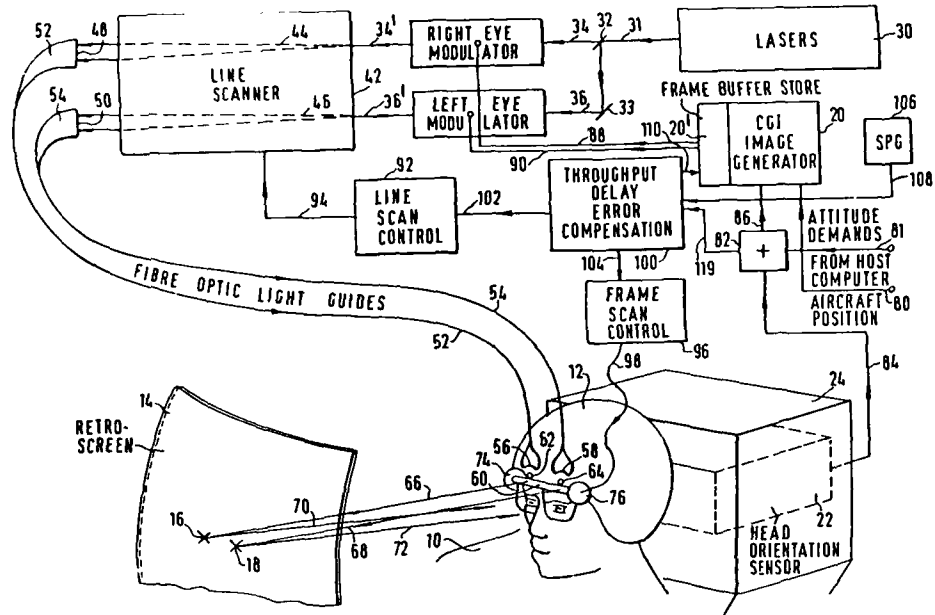

Figure 1

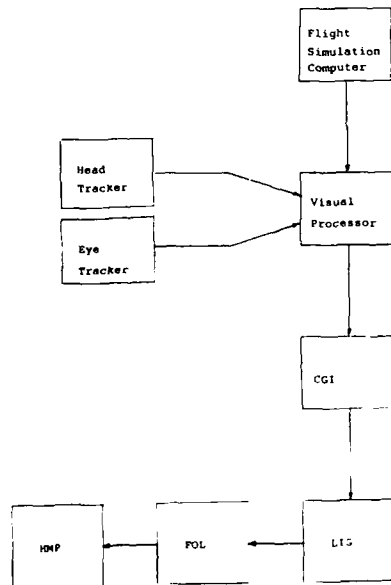

Fig.2 VDRT sub systems

ADVANCED VISUALS IN MISSION SIMULATORS

by

D.A.Cowdrey
 Group Leader — Visual Applications
 Singer Link-Miles Ltd
 Dept 060
 Churchill Industrial Estate
 Lancing, W.Sussex BN15 8UE
 United Kingdom

ABSTRACT

Modern sophisticated full mission flight systems trainers are capable of accurate representation of the actual aircraft in many areas including handling, controls, systems, etc. The major area of inadequacy to date has been the inability to produce a satisfactory visual representation of the outside world. To produce an image to match that of the pilot's field-of-view at the required resolution, is beyond the capabilities of conventional visual system technology. This paper describes various alternative techniques of satisfying this demanding field-of-view/resolution requirement including the technique developed at the Link Flight Simulation Division of the Singer Company, based on an eye-slaved area-of-interest (AOI) concept.

INTRODUCTION

The pilot's field-of-view (FOV) in a modern high performance single seat fighter/attack aircraft such as, for example, the GR5, is approximately 300° azimuth by 40° downward and a nominally unobstructed upper FOV. For adequate training in the ground attack role it is essential that simulator visual systems represent the visual scene at sufficient resolution (2 arc minutes minimum to facilitate realistic target detection) over a FOV large enough to avoid unacceptable pilot compensation due to blind-spots. In attempting to satisfy this demanding requirement we can consider simulator visual systems in two parts; the image generator which produces the actual scene, and the display system which presents the scene to the pilot.

Image Generator

There have been considerable advances in image generation technology over recent years. The early camera model-board systems (CMS) have been improved including the development of wide FOV camera/probe assemblies. A further development of this type of system has been the addition of a scanning laser to replace the camera altogether. The laser beam scans the model at high speed and the resultant reflections from the various facets of the model are received by photo-multiplier-tubes (PMTs) which replace the high-intensity light banks on a conventional camera-based system. The signals received by the PMTs are processed and displayed on a normal CRT/projection system. The main advantage of this technique is that it eliminates the need to illuminate the modelboard which is obviously costly in terms of maintenance and energy costs.

Perhaps the single most important area of development in image generation, however, has been in the field of Computer Generated Imagery (CGI). These systems have progressed from the original light-point only systems to the stage where they are now capable of realistic full-day scene generation. Whilst it is still not possible for CGI to match the quality of scene detail generated by modelboard systems, they are far superior in other respects, including the size of the gaming area, flexibility, FOV, provision of dynamic scene detail, etc, etc. For sophisticated AOI systems where the scene is slaved to the pilot's head and/or eye movement it is not possible to incorporate modelboard systems, due to the high velocities encountered as the pilot changes his line-of-sight. For this reason we must conclude that despite relatively poor scene detail, CGI is the only viable image generation technique for advanced AOI applications.

Display Systems

The conventional display technique is to provide a scene of uniform resolution to the pilot of uniform resolution over the required FOV using either CRTs, viewed through collimation optics or projection onto a screen in front of the pilot. Whilst this approach is satisfactory for less demanding applications and is feasible for the GR5 case, it would require a large number of display channels resulting in high initial cost and problems of alignment and maintainability. Therefore a less conventional approach is required, namely that of an AOI technique.

AREA OF INTEREST TECHNIQUES

Although a large FOV is required for full mission flight systems training applications, it is not all in use at any one time. Instead, the pilot directs his attention to particular parts of the FOV using head and eye movement. By arranging for the high resolution displayed area to be placed where the pilot needs it, only when he needs it, the total FOV can be served with fewer display channels. This argument applies both to display resolution elements and scene detail which in turn results in a saving on display devices and scene generation channels. Visual display systems that use this technique are known as Area-of-Interest (AOI) systems.

The AOI requirement to move resolution to where it is needed corresponds to moving the image from one or more image sources with respect to the pilot. For large CRT monitors, where the image appears on the face of the tube, the requirement translates to moving the monitors themselves. Monitors are only found in collimated displays, where the magnification provided by the collimating optics allows them to present reasonable FOVs without being unacceptably close to the pilot's eye-point. The mass and bulk of both monitor and optics makes their movement hardly feasible. It is possible to consider filling a large FOV with sufficient monitors (collimated) to provide high resolution but only displaying high levels of detail where needed, electronically "handing off" the high detail AOI between display channels. This approach offers no saving of display channels, and if one image generation channel is still required per display channel, no saving in image generation hardware. Thus visual displays using large CRT monitors (e.g. Wide Angle Collimators (WAC's), Pancake Windows) derive little benefit from AOI techniques and so are unlikely to offer an economic solution for large FOV, high resolution applications.

Helmet-Mounted Collimators

Collimators small enough to be moved for AOI are feasible however; the Combat Mission Trainer (CMT) display being developed for the USAF Human Resources Laboratory uses Mini-Pancake Windows (approx. 3" diameter by 1/2" deep) in front of the pilot's eyes. Images from projectors are relayed by coherent fibre-optic bundles to the collimators. In addition to viewing the image in the collimators there is a direct light path through them to give the pilot a view of the cockpit interior. The disadvantages of this approach, some of which are in the process of being resolved, are the weight of the helmet, bulk and drag of the fibre-optic bundles and relatively poor resolution (without eye-tracking).

Head-Trackd AOI

A pilot's visual field extends $\pm 100^\circ$ in azimuth and $+50^\circ$, -70° in elevation with respect to his head. His high resolution field is much more limited, 2 arc minutes or better resolution available only within $\pm 2\frac{1}{2}^\circ$ of his line of sight (LOS). This foveal field can be deflected throughout the large field by eye movement. A possible head tracked FOV might be 90° diameter. At this FOV size, a single 1000 line image source would give 5.4 arc minute resolution. Resolution could be improved by decreasing the FOV, but this might lead to unnatural head and eye movements during visual search and the FOV would have to drop to 33° to achieve 2 arc minute resolution from a single image source. Alternatively, three 1000 line sources could be used for the AOI, but this makes design of deflection optics more difficult. A smaller AOI FOV would ease optical design but make the edge of the AOI more conspicuous, necessitating the provision of a lower resolution image outside the AOI. The resolution provided in the outer field must permit acceptable blending between it and the AOI, and allow for the possibility that the edge of the AOI and beyond might be seen by the pilot's foveal vision. Thus there is a need to minimise the AOI FOV, for high resolution with the fewest image channels and to simplify design of the AOI deflection optics. At the same time, resolution in the outer field should be no higher than absolutely necessary, yet the AOI boundary should be inconspicuous.

It is necessary to distinguish between displays which head-track because they are fixed to the pilot's helmet and off-head projection systems that follow head movement. In an off-head system the helmet attitude sensor determines where the edge of the FOV "window" should be, in which the displayed objects are seen. Provided the direction in which objects are projected is matched by the direction in which they have been calculated by the image generator, projector movement and scene computation can lag head movement without causing image "swimming". Head sensor errors, caused by noise or image generator delays, will cause errors in the position of the edges of the FOV window, but not in the position of displayed objects, which is more critical.

For head mounted display, image direction is tightly coupled to head movement. Head sensor errors translate directly to jitter or swimming of the displayed image. Thus, head sensor performance and image generator delays are critical parameters.

Once a head attitude sensor is incorporated in the visual system it becomes possible to compute the scene perspective for the pilot's instantaneous head position rather than the nominal or design head position. Thus objects in the scene will exhibit parallax behaviour appropriate to their real world range whatever the image distance. In effect, it becomes possible to look around nearby objects. Correct monocular parallax more than compensates for lack of collimation in a real image system and allows the use of smaller domes (i.e. shorter image distances).

Attempting to satisfy all the head slaved requirements discussed above leads to the concept of an eye-tracked AOI system.

Eye-Tracked AOI

An eye-tracked display approach exploits the fact that the high resolution viewing area of the eye is relatively small. This high resolution area is the fovea of the eye which is the only area where small details may be perceived. Surrounding the fovea is a peripheral area where the resolution of detail is low but, because of the way human vision operates, there is a high sensitivity to movement. The psychophysics of human vision creates an image in the "mind's eye" of building a total high resolution image of the real world scene from a series of small high resolution "snap shots", each of which is surrounded by lower resolution information. If this situation is emulated in the visual system, the FOV requirement for instantaneous high resolution and high detail is greatly reduced. Thus, the capacity of the image generator can be concentrated to where it is required and the number of image display channels may be reduced.

As the eye cannot resolve 2 arc minutes or better over more than 5°, a FOV of this size, directed by eye movements over a much larger field, could in principle provide 2 arc minutes resolution over the total FOV. An AOI FOV of between 10-20° is required however if the edge of the AOI is not to be conspicuous. A single 1000 line image source can provide 1.2 arc minute resolution over 20°. Outside a 20° field, centred on the LOS, eye resolution is 5 arc minutes or worse. Thus the background field resolution can be low since the eye cannot bring its high acuity vision to bear on it, and it becomes feasible to consider a small number of fixed projectors for a fairly large background FOV. In addition, as the eye cannot look directly at the edge of the AOI, it becomes easier to inset a region of high detail and resolution within one of lower resolution without a conspicuous boundary.

The problem of unnatural head or eye movements during visual search with a small head tracked FOV has now disappeared. The small, high resolution FOV the pilot now has available to scan the scene corresponds to that available to him in the real world.

In an eye-tracked visual system, the pilot's LOS is monitored and a high resolution, high detail area, surrounded by a large low resolution area, is displayed along that LOS. When the eye's LOS changes, this is sensed and the high resolution area is moved accordingly, matching the eye's ability to discern high detail in only a small area of the total scene at any one time. It creates for the pilot the illusion of high resolution everywhere he looks.

Advantages of Eye-Tracked AOI

The limited resolution of projection systems means that the highest display resolution is achieved with the smallest FOV. Eye-tracking uses the smallest FOV of any AOI technique and therefore provides the best resolution for a given projector technology. Eye-tracking provides the best match between display FOV/resolution and user FOV/resolution, maximising efficiency in the use of image generator and projector capacity.

For a small foveal projected field of about 20° distortion correction problems (arising from separation between pilot's eye-point and projector exit pupil; and displacement of that pupil from the centre of the dome screen) are minimised. This contrasts with other AOI methods where the high resolution field is 40° or greater. At this size, distortion correction requirements are significant. The small projected field angle also allows the use of a foveal projection lens with a small external exit pupil.

A number of benefits accrue from the fact that in an eye-tracked AOI system the background (or peripheral) FOV cannot be looked at directly. The necessary resolution in the background is now less directly determined by visual tasks. If any task requires the pilot to direct his attention to a particular part of the FOV, the high resolution of the foveal channel immediately becomes available at that point. Since only the lower peripheral eye resolution is needed in the background, fewer channels are required, which can be provided by a small number of fixed projectors, avoiding further deflection optics.

Eye-tracking also offers an easier solution to the problem, common to AOI systems, of inseting an area of high resolution within one of the lower resolution without a distracting boundary. For a foveal field of about 20°, the boundary is sufficiently far from the pilot's LOS for it not to be seen directly. An intensity blend region between foveal and peripheral channels is then adequate to disguise the AOI boundary. In addition, the problem of "popping", the sudden appearance of detail in a displayed object as it crosses from high to low resolution areas, is minimised.

Target-Tracked AOI

Until now it has been implicit that the pilot decides which objects in the scene are of interest. Therefore the display must track his head and/or eye movements to bring the high resolution area to that part of the FOV. In some circumstances it is known in advance that an object will be the centre of the pilot's attention once it appears in the scene. In such a case, the high resolution area of the display can be made to track the object position (which is of course known to the image generator) irrespective of the pilot's LOS. The pilot's attention is drawn to the object when it appears in the FOV. Such an object could be a target during weapon delivery, or perhaps a navigation waypoint during transit to the target area.

The original application of the target tracked technique was for air combat simulators. An opposing aircraft would be the only object against featureless sky and ground, which were separated by a low resolution horizon. Image source resolution could be concentrated on the target aircraft. This technique can also be applied to ground targets, but a realistic ground target must be surrounded by a certain amount of visual clutter. This raises the problem of inseting a high resolution area without "spot-lighting" its location, and without such high background resolution that the AOI advantage is lost.

ESPRIT EYE-SLAVED AOI SYSTEM

Singer-Link's ESPRIT (Eye-Slaved Projected Raster Inset) visual system provides a high resolution display area set within a wide FOV background of lower resolution. The display image is presented to the observer by means of a light valve projection system onto a dome screen. Figure 1 shows a typical configuration with the cockpit and projection system housed within a dome screen which is mounted to a motion platform.

Separate projectors are used for the high resolution and background images. The background projection is fixed relative to the observer while the high resolution projection optics are servo-driven and directed by the pilot's eye LOS. A "hole" is cut out of the background image and replaced by the high resolution inset. At the border of this inset the high resolution background images are blended together electronically to give the appearance of a continuous picture.

ESPRIT Configuration

The ESPRIT display system consists of six major components:-

- * Helmet-Mounted Oculometer System (HMOS)
- * Foveal Projection System
- * Peripheral Projectors
- * Merge Electronics
- * Distortion Correction Electronics
- * High-Gain (Motion-Compatible) Dome Screen

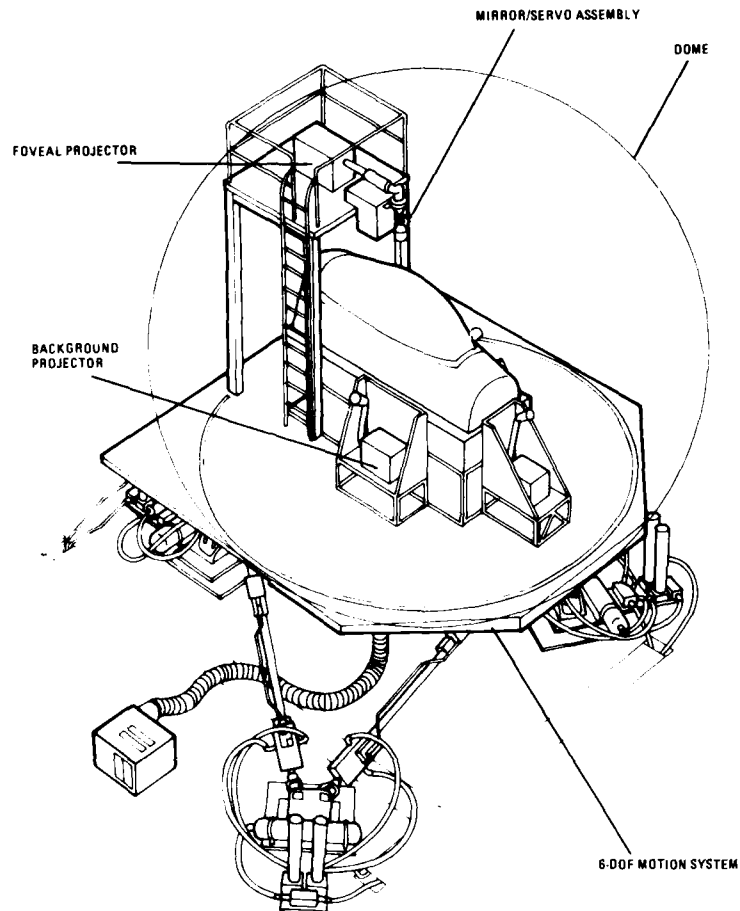

Figure 1 ESPRIT/SIMULATOR CONFIGURATION

Helmet-Mounted Oculometer System (HMOS)

The HMOS consists of two subsystems: a helmet-mounted sight (HMS) and a helmet-mounted oculometer (HMO). The magnetically coupled HMS measures the helmet position and helmet line of sight relative to the observer station, while the HMO measures the observer's eye LOS relative to the helmet. The sight and oculometer measurements are then combined to obtain the eye LOS with respect to the observer station. The resultant eye LOS and helmet position information is used to control the position of the foveal image.

The HMOS uses a charge coupled device camera to view the pilot's eye, which is illuminated by a low-intensity, near-IR light source. The CCD picks up the illuminator's reflection from the observer's cornea along with his pupil image. Using this information, the oculometer system computes the observer's eye LOS with respect to the helmet. A photograph of the HMOS is shown in Figure 2.



Figure 2 HELMET-MOUNTED OCULOMETER SYSTEM

Foveal Projection System

The foveal projection system for the AOI inset image is shown in Figure 3. In addition to the light valve projector display image source, the assembly contains all the optics and servos needed to project the AOI image. The azimuth/elevation servos (shown in close-up in Figure 4) drive the output projection mirror as directed by the observer's eye LOS. (Derotation of the image, required for proper orientation as the azimuth servo turns, is provided in the CGI system). Three other servos are used to maintain constant image size, focus and brightness as the LOS changes and the foveal projection throw distance varies.

The azimuth/elevation servo assembly can accommodate eye saccade step responses with angular velocities that exceed $700^\circ/\text{sec}$ and accelerations of up to $50,000^\circ/\text{sec}^2$.

Peripheral Projectors

The lower resolution background is provided by fixed light valve projectors fitted with wide-angle lens. The ESPRIT configuration shown in Figure 1 incorporating three projectors provides a background FOV of 270° horizontal by 130° vertical to a resolution of 11 arc mins with a peak scene brightness of between 3 and 4 foot-lamberts. This FOV can be increased with the addition of more projectors/image generation channels.

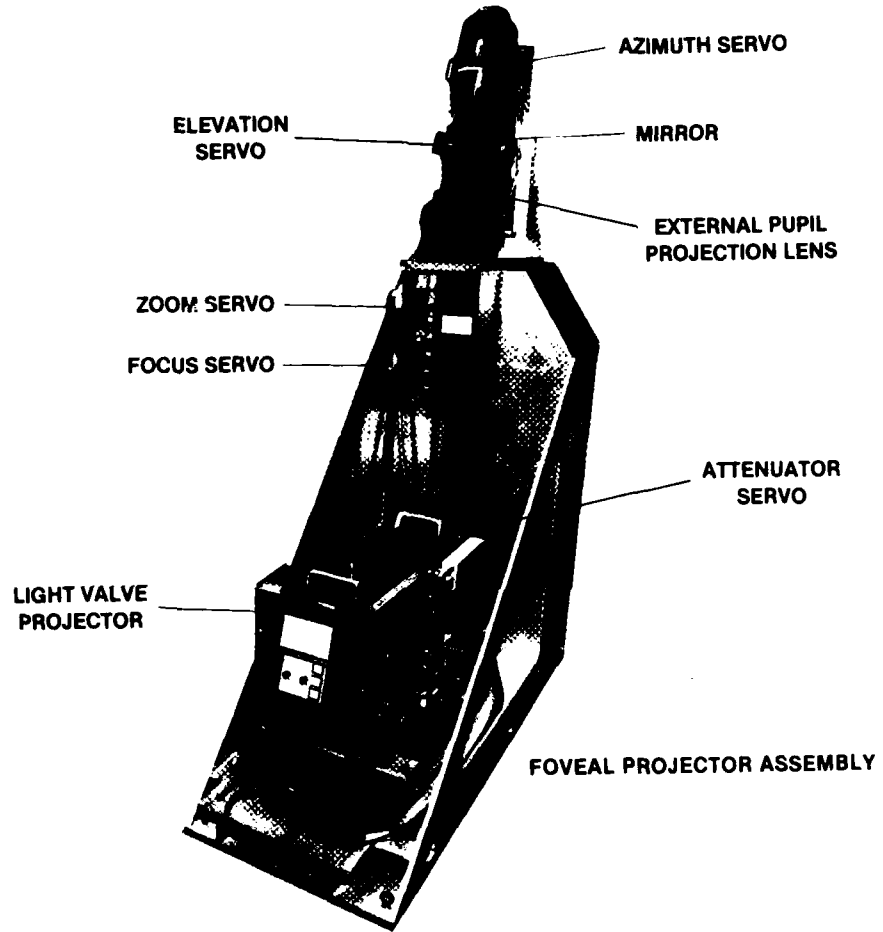

Figure 3 FOVEAL IMAGE PROJECTOR

PROJECTION ASSEMBLY CLOSEUP

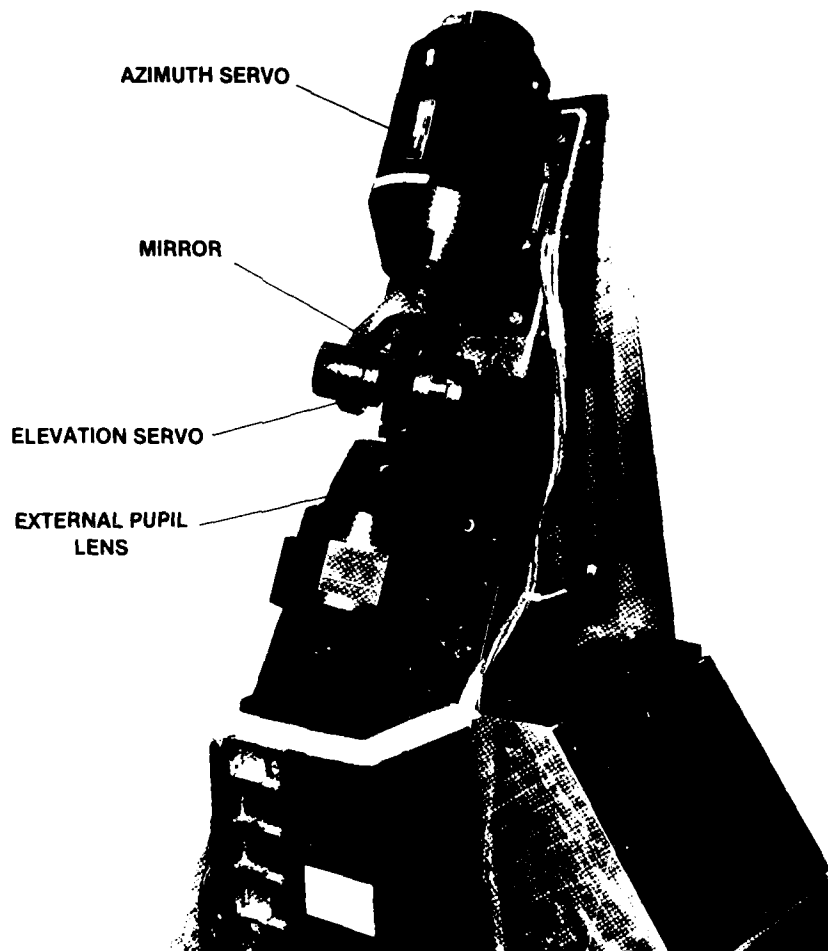

FIGURE 4 CLOSE-UP OF AZIMUTH/ELEVATION SERVO ASSEMBLY

Merge Electronics

The merge electronics provides the proper blending of the foveal image with the peripheral. An elliptical hole is cut out of the peripheral image by blanking the video drive signal for the peripheral projector. The edge of the hole is feathered to blend with the foveal inset. Positioning of the peripheral hole is controlled by the observer LOS. The size of the hole and width of the feather functions are under software control.

The foveal image is similarly shaped by the merge electronics and projected into the peripheral hole. The combined picture gives the appearance of a continuous image.

Distortion Correction Electronics

Distortion correction electronics are necessary to modify the CGI image to compensate for distortion created by projection onto a dome screen. There are two ways of implementing this effect; pre-distortion, where a distorted image is deliberately generated by the CGI such that when projected the pre-distortion is cancelled out. The second approach is to distort or map the normal CGI image electronically using a separate post-processor system. Again this distortion is cancelled when projected. The ESPRIT system incorporates the latter of these two techniques.

SUMMARY

The ESPRIT approach to resolving the demanding FOV/Resolution problem presented by full mission flight system training applications, was to develop a system to match the performance of the human eye both in terms of resolution and angular deflection. In adopting this extremely demanding approach the observer would be provided with high resolution scene detail wherever he looked without the need for large quantities of image generation and display hardware. Research and Development activities over recent years have resulted in the development of a demonstration system which has proved that the eye-slaved area-of-interest concept works successfully. The helmet-mounted oculometer, foveal projector and foveal/peripheral merge electronics have been built, tested and integrated into an engineering test bed.

Although this test bed does not represent the final simulator environment, the knowledge gained has addressed all the essential questions regarding the technical performance and psychophysical aspects of the AOI concepts. The test bed used a single background projector and a flat display screen providing a 74° horizontal by 67° vertical FOV to the observer. The observer sits in a wooden mock-up cockpit with a simple throttle and attitude control stick. The imagery was provided by a first generation Link DIG CGI system. The test bed AOI inset was a nominal 18° diameter circle and therefore the performance is essentially identical to the final proposed system except the total FOV was limited to that of the flat screen.

Engineering Evaluation

Engineering tests were performed to verify that the requirements of static and dynamic performance could be met. These tests evaluated the following parameters:-

- * System throughput from eye to final image and head to final image.
- * AOI to background dynamic response match.
- * AOI resolution.
- * Distortion and pointing performance.
- * Background image resolution and distortion performance.

Psychophysical Evaluations

Approximately thirty subjects were used in two intensive series of psychophysical evaluations in which five display parameters were quantitatively and qualitatively evaluated. The evaluations address the following aspects:-

- * AOI size
- * Merge size
- * Foveal/peripheral image brightness match
- * Peripheral image update rate
- * System throughput

In addition to the test bed evaluation, Link has developed a 24 ft diameter motion comparable high gain display screen dome, a 205° wide angle lens for the peripheral projectors and a digital mapper that will remove the static distortion in the wide angle peripheral image due to display geometry, wide angle lens and spherical display screen.

A total eye slaved AOI technology demonstrator in the dome covering a 180° horizontal by 130° vertical background FOV is scheduled for completion by mid 1984.

ACKNOWLEDGEMENTS

I wish to express my gratitude to Robert A. Fisher, Programme Engineer on the Eye-slaved Display Integration and Test (EDIT) Program at Link Flight Simulation Division of the Singer Company. His assistance in support of the preparation of this paper has been invaluable in terms of the supply of information and the current status of the EDIT Programme together with photographs and sketches of the EDIT system.

References

1. Fisher R.A. and B.M. Progress Report on an Eye-slaved Area-of-Interest Visual Display, INAE Conference, Phoenix, Arizona, 1984.

THE APPLICATION OF OPTIMAL CONTROL TECHNIQUES
TO THE UTIAS RESEARCH SIMULATOR

by

L. D. Reid
Professor and Associate Director

University of Toronto, Institute for Aerospace Studies
4925 Dufferin Street
Downsview, Ontario, Canada
M3H 5T6

SUMMARY

Optimal control has found many aerospace applications in recent years. This paper describes two such applications to flight simulators. The first involves the generation of wind shear effects for use in training exercises. This work included simulator trials and an assessment of the process by a number of pilots. The second application is to the generation of simulator motion-base drive signals in a six degrees-of-freedom facility. In this case the optimal controller is composed of a series of filters that act much like a classical washout algorithm. Vestibular models which predict the sensation of motion by the pilot are incorporated within the optimal controller and are also used to evaluate its overall performance.

1. INTRODUCTION

This paper deals with two distinct applications of optimal control techniques to flight simulation. This research has evolved as the result of a major commitment on the part of the University of Toronto Institute for Aerospace Studies to expand its expertise in the simulation area. The first project concerns the creation of wind shear profiles for effective pilot training. The second deals with the generation and sensing of physical motion in a synergistic six degrees-of-freedom simulator.

2. SHEAR GENERATION USING WIND CONTROLLERS

When developing wind profiles to be used for training or evaluation purposes it is useful to be able to control the degree of difficulty they represent. In certain instances one may wish to employ wind profiles that are the worst in some sense for a given average wind energy. As reported in References 1 and 2 it is possible to apply differential games theory to this worst-case wind generation problem. In the present study we apply this technique to the simulation of an aircraft on the landing approach.

2.1 Applying Differential Games Theory

The underlying theory is linear in nature and thus we start with a set of linear differential equations describing the aircraft on the landing approach.

$$\dot{\underline{x}} = \underline{F} \underline{x} + \underline{G}_1 \underline{u} + \underline{G}_2 \underline{w} \quad (1)$$

Here \underline{x} is the aircraft state vector, \underline{u} is the aircraft control vector and \underline{w} is the wind disturbance vector. In our applications \underline{u} is made up of control rates (such as elevator, aileron, rudder and throttle rates of change) and \underline{w} is made up of the wind velocity rates of change as sensed at the aircraft center of mass. The state vector \underline{x} is augmented to include the actual control surface deflections and throttle setting. This latter organization is useful in allowing additional degrees-of-freedom in the wind generation process.

A cost functional J is now formed as

$$J = \underline{x}_{t_f}^T \underline{S} \underline{x}_{t_f} + \int_0^{t_f} [\underline{x}^T \underline{Q} \underline{x} + \underline{u}^T \underline{R}_1 \underline{u} + \mu \underline{w}^T \underline{R}_2 \underline{w}] dt \quad (2)$$

In its most general form, the problem is to select a control vector \underline{u} that tends to minimize J and a wind vector \underline{w} that tends to maximize J subject to a wind energy constraint represented by

$$-\int_0^{t_f} \underline{w}^T \underline{R}_2 \underline{w} dt < E \quad (3)$$

where t_f is the duration of the landing approach, x_{t_f} is the aircraft state at time t_f , $S > 0$, $Q > 0$, $R_1 > 0$ and $R_2 < 0$. Including both \underline{u} and \underline{n} in J ensures finite control and wind inputs to the aircraft system.

If a minimax solution (Nash equilibrium) is sought to this problem using differential games theory then an optimal control \underline{u} and a worst-case wind \underline{n} results. If a one-sided maximization of J is sought where \underline{u} is absent (i.e., controls fixed) then \underline{u} is set to zero in Equations 1 and 2 and the result is the so-called direct method.

The optimal control \underline{u}^* and worst-case wind \underline{n}^* are given by:

$$\underline{u}^* = [-R_1^{-1} G_1^T P] x \quad (4)$$

$$\underline{n}^* = [-\frac{1}{\mu} R_2^{-1} G_2^T P] x \quad (5)$$

$$\dot{P} = -P F - F^T P + P [G_1 R_1^{-1} G_1^T + \frac{1}{\mu} G_2 R_2^{-1} G_2^T] P - Q \quad (6)$$

$$P(t_f) = S \quad (7)$$

Here P is the solution to the matrix Riccati equation. The solution for the direct method involves \underline{n}^* but not \underline{u}^* and the term $G_1 R_1^{-1} G_1^T$ is dropped from Equation 6. The interesting feature of these formulations is that they result in a state feedback wind controller for \underline{n} (Equation 5) which can be easily installed on a manned flight simulator.

2.2 Implementation of Wind Controllers

Both the differential games wind model and the direct method wind model were implemented for the case of a light STOL transport performing an ILS approach on a 7° glideslope. In the present case only the longitudinal flight equations were used. When these wind controllers were employed in tests involving human subjects it was found that in some cases they could capitalize on the humans' less than optimal control to produce excessively large wind inputs. In order to reduce the impact of this, preselected envelopes were used to limit the wind velocities. These envelopes are presented in Figure 1. Here W_1 represents horizontal and W_2 vertical wind components. The winds were restricted to lie within these bounds. The numerical data pertaining to the aircraft and the various controller matrices are contained in Reference 1. The weighting matrices were selected so that significant deviations in the aircraft state from the reference state (no wind present) resulted. In order to simplify the application of the wind models the time-varying control law of Equation 5 was replaced by a time-invariant approximation formed by replacing $P(t)$ by $\lim_{t \rightarrow \infty} P(t)$ in the case of the differential games model and by $P(0)$ in the case of the direct method model (for which $\lim_{t \rightarrow \infty} P(t)$ could not be found due to the presence of conjugate points). The resulting wind controllers were:

$$\begin{bmatrix} \dot{W}_1 \\ \dot{W}_2 \\ \dot{W}_3 \end{bmatrix} = C [u \quad w \quad q \quad \theta \quad \delta_E \quad \delta_T]^T \quad (8)$$

where u and w are the x and z velocity components, q the pitch rate, θ the pitch attitude, and δ_E and δ_T the elevator and throttle deflections. For the differential games model:

$$100 C = \begin{bmatrix} -29.9 & -0.722 & 32.6 & 108 & 82.1 & -73.0 \\ 1.36 & -4.00 & 14.3 & 146 & -83.4 & -3.44 \end{bmatrix} \quad (9)$$

In the case of the direct method model an effective reduced order wind controller was found, given by:

$$100 C = \begin{bmatrix} -36.5 & -19.5 & 219 & 1,290 & 0 & 0 \\ 0 & 0 & 0 & 0 & 0 & 0 \end{bmatrix} \quad (10)$$

2.3 Simulator Trials of Wind Controllers

The flight simulator trials were performed with fixed-base conditions in a part task simulation under IFR. Only the longitudinal degrees-of-freedom of a light STOL transport were represented. The task consisted of intercepting a 7° ILS glidepath from level flight at 460m and flying an approach down to a 60m decision height. Five pilots took part in the trials. Their qualifications are listed in Table 1. Cockpit instrumentation consisted of an airspeed indicator, altimeter, engine power indicator

and an electronic attitude indicator with fast/slow and glidepath deviation bugs (see Figure 2). The controls employed were elevator, throttle and pitch trim.

Two sets of runs were performed. In the first (involving Pilots 1 and 2) subjective evaluations of the winds generated by the controllers were sought. In the second (involving Pilots 3 to 5) learning effects associated with the wind controllers were studied.

In order to start the wind controller process it is necessary to introduce perturbations in the aircraft state vector x . If this is not done in the flight simulator environment it is possible that very small wind effects could result. This perturbation was achieved in the present case by superimposing the wind-controller outputs on the modest linear wind shear in W_1 represented by Figure 3.

2.4 Subjective Evaluation of Wind Controllers

Typical wind profiles generated during the testing of the differential games model are shown in Figure 4. Figure 5 contains typical wind profiles generated when the direct method model was employed. For comparison purposes the pilots also flew approaches using just the linear shear of Figure 3 and a set of wind profiles corresponding to those encountered during the fatal accident at JFK International Airport in 1975.

It can be seen from Figures 4 and 5 that the same wind controller produces different wind profiles on each flight. This results from variations in the exact time histories of the state vector x on each approach.

Both pilots found the wind controller models useful for training purposes, although for some of the runs they felt that the winds they had encountered were unrealistically severe. It should be noted that they felt that the JFK wind profile was also unrealistically severe.

2.5 Learning Effects

Pilots 3 to 5 took part in a series of trials to determine whether the shears generated by the wind controllers would result in learning effects significantly different from those observed when pilots were exposed to the same single wind profile time after time. In this experiment a secondary task was employed in an attempt to measure spare mental capacity during the trials. This phase of the work is described in Reference 3.

The secondary task employed consisted of observing a randomly generated single digit between 1 and 9 which appeared in the top right-hand corner of the electronic attitude indicator. The pilot was required to recognize the digit as either even or odd and respond by deflecting a control wheel mounted switch either to the left or right. This was a self-paced task in which the displayed digit did not change until after the pilot had responded. They were told that good performance on the primary task was the main objective of the experiment, and to attend to the secondary task only when they thought that it would have little adverse effect on their performance on the primary task. However, they were instructed to give due attention to the secondary task and to try to do their very best on it also.

It was found that the pilots attended to the secondary task at intervals which would allow them to achieve perfect identification. Thus the mean time between responses to the secondary task became the measure of additional mental capacity over and above that required by the primary task (the control of the landing approach in wind shear).

For comparison purposes two fixed wind profiles similar to those in Figures 4 and 5 were also employed. Following a training period, each subject carried out 20 landing approaches with each of the two wind controllers (given by Equations 8 to 10) and with each of the two fixed wind profiles.

It was found that a range of learning curves resulted for both the wind controllers and the fixed wind profiles. In general these were fairly flat (based on RMS glidepath deviation and airspeed deviation for the primary task and the mean time between responses for the secondary task). No significant differences could be found between the results produced by these two distinctly different approaches to wind generation.

3. SIMULATOR MOTION

As part of the process of developing our new research simulator facility (see Figure 6) a review of potential motion drive techniques was carried out. Although quite a number of useful reports were found, it was felt that a systematic comparison of several available techniques as applied to a synergistic six degrees-of-freedom motion-base was needed before a choice could be made for our particular application.

3.1 Motion-Base Drive Algorithms

The ultimate purpose of this study is the selection of an algorithm suited to the

simulation of transport-type aircraft on the new simulator facility. The general motion limits of the system are contained in Table 2.

Three candidate motion-base algorithms have been selected for evaluation:

- (1) classical washout^{5,6}
- (2) optimal control⁷
- (3) adaptive control⁸

Both classical washout and optimal control employ fixed parameter filters acting on the output from the flight equations to restrict the motion commands sent to the simulator hardware. Because the filter parameters must be selected to handle the most severe situation it follows that for much of the time these filters are overly restrictive. On the other hand, the adaptive control algorithm is designed to alter the filter parameters in response to the simulator state and thus has the potential to overcome this problem. The optimal control scheme proposed in Reference 7 has the interesting feature that it incorporates a mathematical model predicting the pilot's sensation of motion. Part of the optimizing process deals with matching the sensation of motion in the simulator to that experienced in the aircraft. The above three algorithms have been implemented on a digital computer and a number of preliminary evaluation trials carried out.

The general form representing all three algorithms is given schematically in Figure 7. The inputs are based on the simulated aircraft's translational and rotational motion. These signals are processed by filters to generate simulator motion commands that are within the physical capabilities of the hardware. From these commands the signals sent to each of the six hydraulic actuators of the motion-base are computed. The aircraft translation to simulator rotation cross-feed represents the tilt-coordination process which employs simulator tilt to represent sustained specific force. The general properties of these filters are summarized in Table 3. This paper will concentrate on describing the experience we have gained to date with the optimal control algorithm.

3.2 The Optimal Control Motion Drive Algorithm

The basic formulation of the optimal control algorithm as conceived in Reference 7 is depicted in Figure 8. Given the aircraft motion u^a the problem is to determine the simulator motion u^s that minimizes the cost functional

$$J = E[\underline{e}^T \underline{Q} \underline{e} + \rho[\underline{u}^{sT} \underline{R} \underline{u}^s + \underline{y}d^s \underline{R}_d \underline{y}d^s]] \quad (11)$$

where

$$\underline{Q}, \underline{R}_d > 0, \quad \underline{R} > 0$$

This cost functional contains several terms and these are described below with reference to Figure 8. Since the purpose of simulator motion is to create a sensation of motion for the pilot, a vestibular model is included within the system equations. The output of this model estimates the angular velocity and specific force sensed by the pilot both in the aircraft (y^a) and in the simulator (y^s). The optimal control seeks a solution u^s that tends to minimize the sensation error:

$$\underline{e} = \underline{y}^a - \underline{y}^s. \quad (12)$$

In order to restrict the travel of the motion-base a penalty is imposed by including in J simulator motion u^s and integrals of u^s represented by $\underline{y}d^s$. The relative values of the weighting parameters \underline{Q} , ρ , \underline{R} and \underline{R}_d determine to some extent the features of the optimal controller. As one would expect there is a trade-off between sensation fidelity and simulator motion-base travel.

The optimal solution is sought under the following assumptions:

- (1) u^a is represented by filtered white noise
- (2) the simulator motion-base responds perfectly to all commands
- (3) all system equations are linear

The resulting closed-loop formulation is depicted in Figure 9. The state feedback matrix

$$\underline{F} = [\underline{F}_1^T \quad \underline{F}_2^T \quad \underline{F}_3^T]^T \quad (13)$$

comes from the solution of an algebraic Riccati equation (see Reference 4 for details). The corresponding open-loop formulation of the controller can be shown to be

$$\underline{u}^s = \underline{W}(s) \underline{u}^a \quad (14)$$

where $\underline{W}(s)$ is a matrix of system transfer functions. Equation 14 forms the basis of the computer algorithm employed in the present study. A few comments on the dimension of $\underline{W}(s)$ can now be given. The number of transfer function elements in the matrix $\underline{W}(s)$ is found to be $[\text{number of elements in } \underline{u}^s]^2$. Thus in the most general case where \underline{u}^s has three rotational and three translational elements, $\underline{W}(s)$ will contain 36 individual transfer functions. As suggested in Reference 7, this number can be reduced by

treating the system as four isolated sub-systems consisting of the following groupings of the degrees-of-freedom:

- (1) pitch/surge
- (2) roll/sway
- (3) yaw
- (4) heave.

Although this leads to a sub-optimal solution to the overall problem, the number of individual transfer functions involved is reduced to 10.

In addition, in each of the above sub-systems the order of the individual transfer functions contained in $W(s)$ is found to be equal to the sum of the orders of the differential equations representing the vestibular models and the system kinematics (see Figure 8). For this reason it may be advantageous to use low-order vestibular models and kinematics.

The general form of $W(s)$ can be shown to be

$$W(s) = [-I + F_2(sI - A + B F_2)^{-1}B][F_1(sI - A)^{-1}B + F_3] \quad (15)$$

where A and B are system matrices. In order to formulate the differential equations represented by Equation 15, which are necessary when writing the motion-base drive computer algorithms, it must be expanded as a ratio of polynomials in the Laplace variable s . This is best achieved by using a symbolic manipulator computer routine such as FORMAC or MACSYMA.

Once the corresponding filter equations have been developed, they are then applied to the actual simulator, which by its very nature is nonlinear. The resulting control is thus further sub-optimal. Figure 10 depicts such an application. β_{AA} and β_A represent the simulated aircraft's translational acceleration in body axes components and Euler angles. L_{rs} is a transformation matrix used to generate signals representing desired simulator translational acceleration in inertial reference frame components. The optimal control provides both direct and cross-coupling paths to produce the simulator translational acceleration (β_{SI}) and Euler angles (β_S) in inertial reference frame components.

Figure 11 shows the frequency responses of the filter transfer functions for the roll/sway channels for one case under study. Here the optimal control weighting parameters in Equation 11 have been selected so that the motion-base actuator extensions for a number of typical six degrees-of-freedom maneuvers in a Boeing 747 remain just below the UTIAS simulator's limits. These plots demonstrate the essential features found for this formulation of the optimal controller. The translation to translation filter W_{22} is high-pass. The rotation to rotation filter W_{11} has a unity transfer function. The translation to rotation filter W_{12} (tilt-coordination) is low-pass. The rotation to translation filter W_{21} is high-pass but so small in amplitude that it can be replaced by zero.

Figure 12 shows the influence of this set of filters on the simulation of a sequence of turn entries. The general features of the simulated aircraft maneuver can be seen from its bank angle (PHIA A/C) and heading angle (PSIA A/C) time histories. The signals fed to the simulator were all first attenuated by a factor of 0.5 before being processed by the optimal controller. The resulting simulator bank angle (PHI SIM) is a much reduced version of the corresponding aircraft bank angle. This reduction (beyond the scaling of 0.5) is due to the W_{12} roll/sway crossfeed. The reduction in heading angle magnitude (PSI SIM) is due to the yaw channel optimal controller which has the form of a high-pass filter. The large lateral simulator motion (YSI SIM) is an attempt by the algorithm to remove some of the unwanted specific force in the simulator caused by simulator roll response.

The motion sensations experienced by the pilot were predicted using linear vestibular models. The details of these computations are contained in Reference 4. The sensed specific side-force (SFY) is seen to cause the optimal motion-base controller some difficulty. The simulator values are almost three times those found in the aircraft despite the use of a significant portion of the simulator's lateral travel in an attempt to reduce this. Simulated roll (SP) and yaw (SR) angular velocity sensation is typical of that which can be achieved in a simulator with rather limited travel capability.

4. CONCLUSIONS

- (1) Optimal control techniques can be successfully employed in a number of simulator applications.
- (2) Wind controllers can be used to simulate challenging wind shears in a form that is useful for simulator training applications.
- (3) Optimal simulator motion-base controllers have filter characteristics similar to those found in classical linear washout algorithms. For this reason they are also subject to similar advantages and disadvantages.

(4) Optimal motion-base controllers allow the designer to make trade-offs between different degrees-of-freedom and between fidelity and simulator travel in a direct and simple manner.

REFERENCES

1. Markov, A. B., "The Landing Approach in Variable Winds: Curved Glidepath Geometries and Worst-Case Wind Modeling", University of Toronto, UTIAS Report No. 254, December 1981.
2. Markov, A. B., Reid, L. D. and MacKenzie, R. B., "On-Line Wind Shear Generation for Flight Simulator Applications", Journal of Aircraft, Vol. 19, No. 7, July 1982, pp. 553-558.
3. Lam, D. K. W., "A Flight Simulator Study of Pilot Adaptation to Wind Shear Generated by Worst Case Wind Modelling Techniques", M.A.Sc. Thesis, University of Toronto, Institute for Aerospace Studies, January 1983.
4. Reid, L. D. and Nahon, M. A., "Flight Simulation Motion-Base Drive Algorithms: Part 1 - Developing and Testing the Equations", University of Toronto, UTIAS Report No. 296, March 1985.
5. Schmidt, S. F. and Conrad, B., "Motion Drive Signals for Piloted Flight Simulators", NASA CR-1601, May 1970.
6. Parrish, R. V., Dieudonne, J. E. and Martin, D. J. Jr., "Motion Software for a Synergistic Six-Degree-of-Freedom Motion Base", NASA TN D-7350, December 1973.
7. Sivan, R., Ish-Shalom, J. and Huang, J-K., "An Optimal Control Approach to the Design of Moving Flight Simulators", IEEE Transactions on Systems, Man, and Cybernetics, Vol. SMC-12, No. 6, Nov./Dec. 1982, pp. 818-827.
8. Parrish, R. V. and Martin, D. J. Jr., "Comparison of a Linear and a Nonlinear Washout for Motion Simulators Utilizing Objective and Subjective Data from CTOL Transport Landing Approaches", NASA TN D-8157, June 1976.

ACKNOWLEDGEMENTS

The work reported in this paper was supported by the Natural Sciences and Engineering Research Council of Canada and by the Transportation Development Centre of Transport Canada. The author would like to thank the following researchers for their significant contributions: M. A. Nahon, A. B. Markov, R. B. MacKenzie and D. K. W. Lam.

TABLE 1
PILOT SUBJECTS

SUBJECT	CLASSIFICATION	TOTAL HOURS	PREVIOUS SIMULATOR HOURS
1	Test Pilot	13,000	400
2	Instructor	950	9
3	Private Pilot	60	3
4	Private Pilot	110	1
5	Private Pilot	120	-

TABLE 2
UTIAS RESEARCH SIMULATOR MOTION LIMITS

Pitch	maximum excursion	+28°, -34°
	maximum velocity	34°/s
	maximum acceleration	400°/s ²
Roll	maximum excursion	+28°
	maximum velocity	34°/s
	maximum acceleration	400°/s ²
Yaw	maximum excursion	±30°
	maximum velocity	34°/s
	maximum acceleration	400°/s ²
Vertical	maximum excursion	+0.63, -0.56m
	maximum velocity	0.8 m/s
	maximum acceleration	15 m/s ²
Lateral	maximum excursion	±0.75m
	maximum velocity	0.8 m/s
	maximum acceleration	15 m/s ²
Longitudinal	maximum excursion	+0.80, -0.92m
	maximum velocity	0.8 m/s
	maximum acceleration	15 m/s ²

TABLE 3
FILTER CHARACTERISTICS

	T→T	T→R	R→R	R→T
Classical	High-Pass	Low-Pass	High-Pass	—
Optimal	High-Pass	Low-Pass	Flat	High-Pass
Adaptive	Variable (High-Pass)	Variable (Low-Pass)	Variable (High-Pass)	—

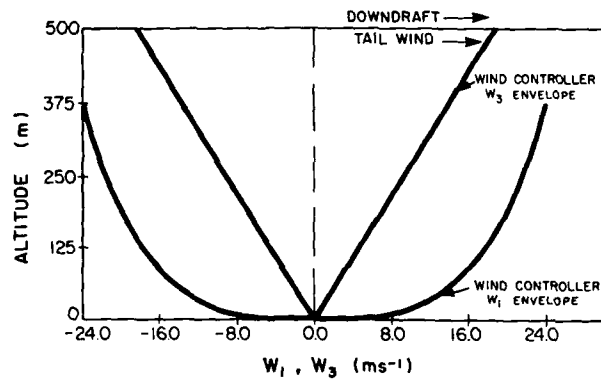

Figure 1. Wind Controller Envelopes.

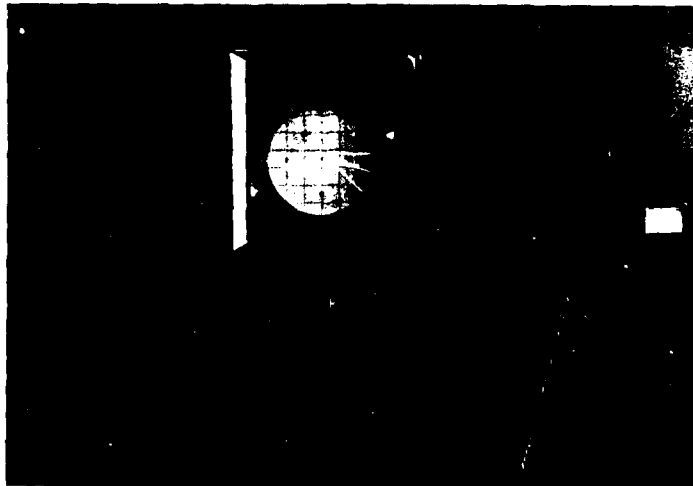

Figure 2. Instrument Display.

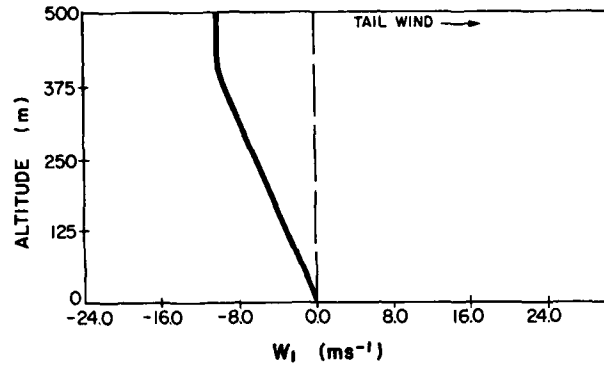

Figure 3. Linear Wind Shear Profile.

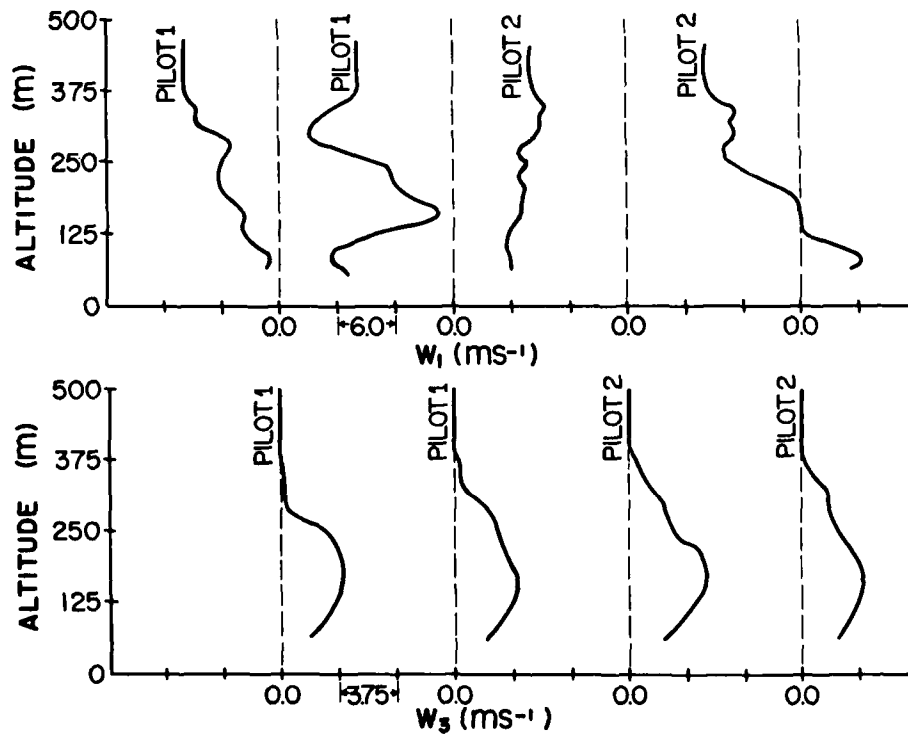

Figure 4. Winds Produced by the Differential Games Model.

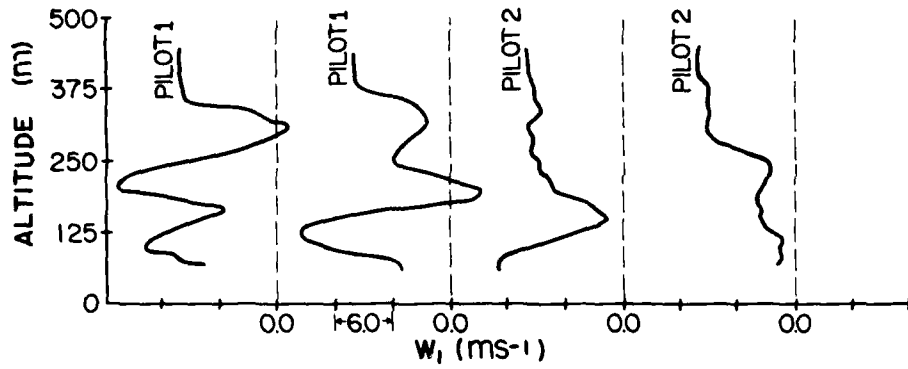

Figure 5. Winds Produced by the Direct Method Model.



Figure 6. UTIAS Flight Research Simulator.

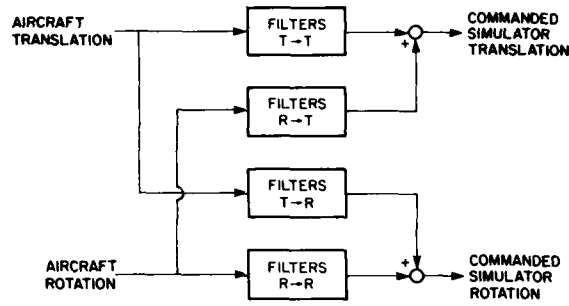

Figure 7. General Form for Motion-Base Drive Algorithms.

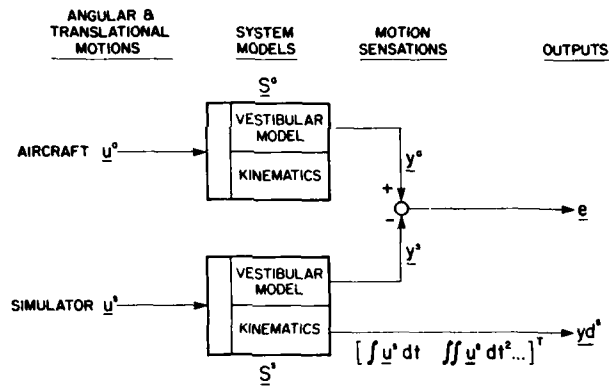

Figure 8. Optimal Simulator Problem.

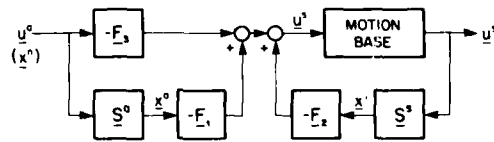

Figure 9. Closed-Loop Formulation of the Optimal Simulator Controller.

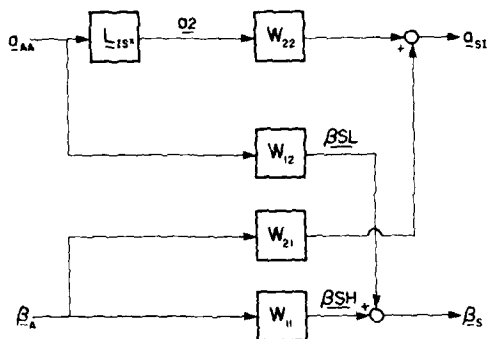

Figure 10. Open-Loop Implementation of the Optimal Simulator Controller.

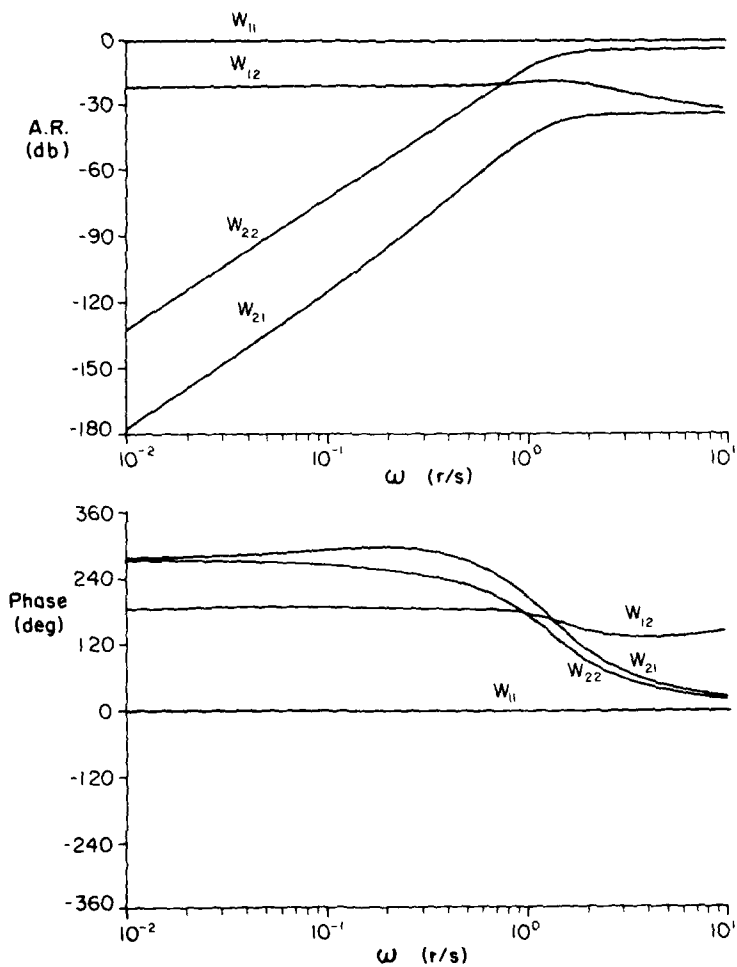

Figure 11. Frequency Response of \underline{W} for the Roll/Sway Channels.

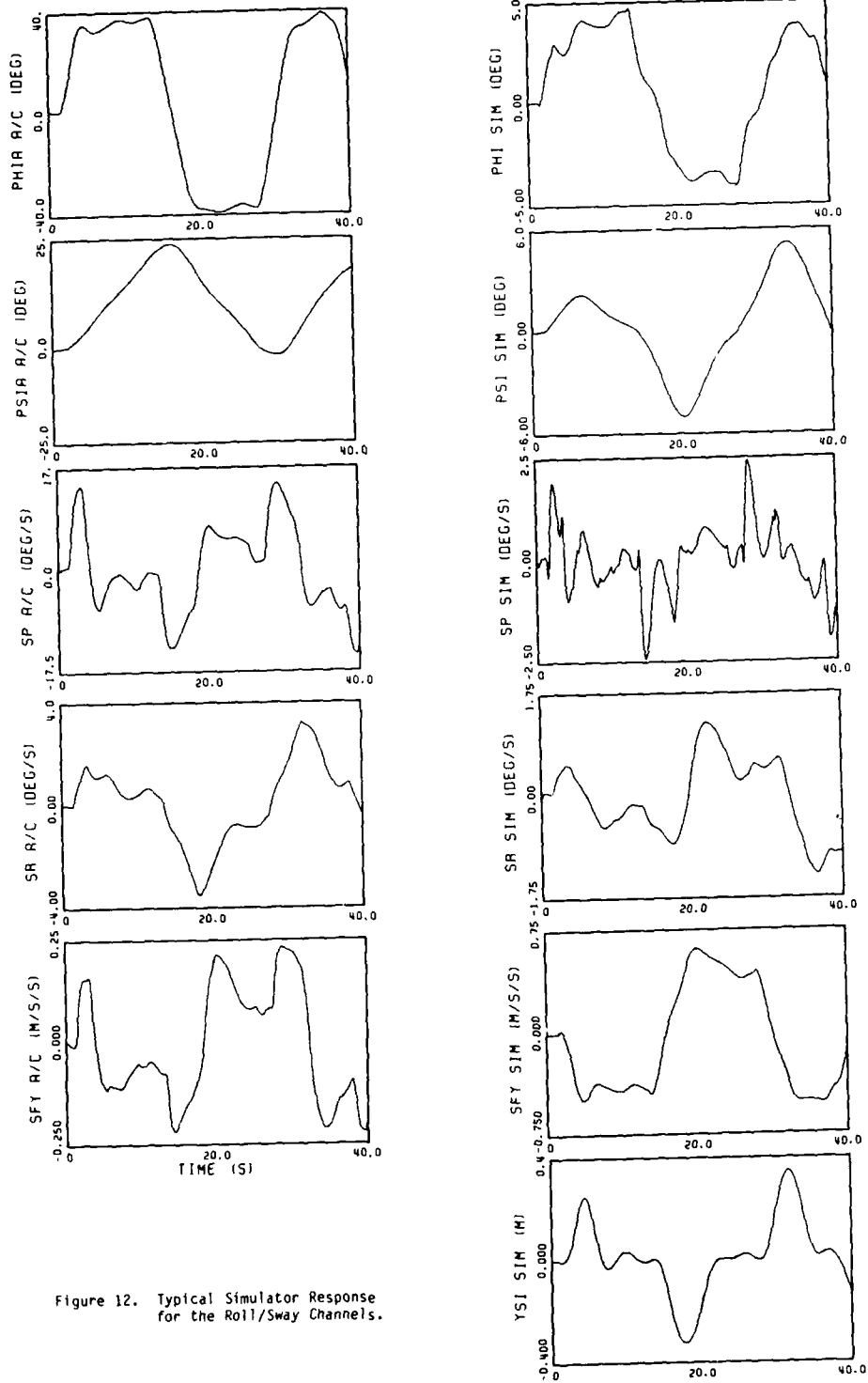

Figure 12. Typical Simulator Response for the Roll/Sway Channels.

"QASIS" - UN OUTIL MODERNE POUR LA SIMULATION TEMPS REEL

J. Benoit, Avions Marcel Dassault-Breguet, Istres, France

"VOIR"

Pour le pilote de chasse, il est primordial de bien voir le ciel autour de l'avion, avec le plus grand champ possible ; en effet, rien ne concurrence l'oeil pour la qualité de détection et pour l'évaluation d'une situation aérienne.

Les radars, calculateurs, aides diverses dont disposent les avions modernes fournissent beaucoup d'informations mais leur interprétation est laborieuse, réclame un *entraînement* suivi. Leur domaine d'emploi est celui où la vision directe est impossible. Mais dès que celle-ci est établie le pilote dispose d'une nouvelle dimension d'information : son appréciation de l'attitude des avions le renseigne sur les "intentions" des adversaires. Le choix de la meilleure tactique est plus aisé.

Dans un combat rapproché, la visibilité permanente de l'ennemi est indispensable pour ne pas perdre "le dixième de seconde" dans l'évaluation de la manoeuvre à effectuer. Dans ces conditions, l'obligation de lire une altitude ou un mach en cabine peut faire perdre le contact visuel et peut-être le combat.

On comprend la pression exercée par les pilotes pour minimiser ces inconvénients et faire "monter" dans le viseur les informations de *voilà les plus importantes*.

Depuis la fin de la dernière guerre mondiale, seules les figurations réservées au tir des armes étaient collimatées dans un viseur et projetées sur le monde extérieur. Tant que l'animation des réticules est restée électromécanique, peu d'informations de vol ont été présentées. C'est depuis l'apparition du tube cathodique comme générateur de réticules qu'a débuté une évolution rapide des collimateurs puis des cockpits.

COCKPITS DE VERRE

L'emploi des tubes cathodiques n'est pourtant pas si récent ; des *scopes radars* étaient embarqués dès les années 60, avec toutefois des luminosités un peu faibles pour l'ambiance lumineuse d'un cockpit de chasseur. Il fallait les protéger par des casquettes généreuses.

C'est aussi la prise en compte du nombre d'armements nouveaux, de la nécessité d'une grande souplesse d'adaptation aux conditions d'emploi qui a suscité des applications beaucoup plus variées du tube cathodique.

La notion d'information présentée quand elle est nécessaire, et non en permanence, permet l'utilisation en "temps partagé" des surfaces de cockpit disponibles.

On assiste donc à la prolifération de tubes cathodiques au détriment des anciens instruments électromécaniques.

L'art du concepteur de cockpit s'en trouve profondément modifié : au lieu de traiter des dispositions d'instruments, de faire réaliser des équipements répondant aux nouveaux besoins, des boîtes de commandes spécialisées, il lui faut créer des images, les faire vivre et évoluer pour une utilisation optimale en fonction des phases de vol.

MISE AU POINT DES IMAGES

Le traitement de l'image est un sujet très actuel, beaucoup de systèmes existent pour fabriquer des images. Mais dans l'application qui nous intéresse, il faut *animer* les images comme elles le seront en vol pour juger dès leur conception de leur bonne adaptation à la fonction désirée.

La solution est connue : c'est le simulateur de vol.

Malheureusement ce type d'appareil est très cher, donc peu répandu ; il n'est donc pas accessible pour des expérimentations très ponctuelles. D'autre part, il n'offre pas la souplesse désirée lors de recherches préliminaires tant au niveau matériel que logiciel. Car la mise au point d'une figuration suppose la possibilité de modifications opérées rapidement pour que la comparaison soit efficace : à quelques minutes d'intervalle, deux solutions sont faciles à comparer finement ; à quelques jours d'intervalle c'est déjà plus grossier.

Le système développé aux AMD/BA est un pari de large simplification de la partie "matérielle" du simulateur, donc d'une importante réduction de prix.

HISTORIQUE DE LA MACHINE DAISY :

(Dispositif d'Animation d'Images Synthétiques)

La première approche est presque uniquement logicielle. Utilisant un ordinateur des Essais en Vol aux "heures creuses", une simulation sommaire d'un MIRAGE 2000 anime les réticules de la VTH (visualisation tête haute) et de la VTB (visualisation tête basse) présenté sur un tube cathodique couleur à pénétration géré par un système graphique. L'interface pilote est une console dont on a reprogrammé le clavier.

L'animation est très parlante, le pilotage par poussoirs fastidieux. Un manche miniature (pour télécommande) améliore un peu le pilotage mais révèle le besoin d'un accès pratique aux commandes du système d'armes, surtout à celles disposées dans l'avion sous les doigts du pilote.

Malgré ses défauts, cet outil se révèle vite très utile pour discuter à plusieurs utilisateurs, de répartition de réticules, de tailles de caractères. Il se révèle aussi un matériel d'instruction très efficace et très apprécié.

La construction d'une interface plus fonctionnelle est décidée : adaptation d'un manche pilote et de la manette du MIRAGE 2000 sur des bras support ajoutés à la structure d'une console classique à pupitre.

Manche et manette comportent toutes les commandes classiques (trims, poussoirs divers). La manette est articulée et commande un potentiomètre, le manche très court présente des efforts analogues à ceux de l'avion avec des déplacements réduits. Il n'y a pas de palonnier, cette commande n'intervenant que pour du pilotage pur (décrabe, correction de visée).

Sur le pupitre un poste de commande radar simplifié, un poste de commande armement recopiant parfaitement celui de l'avion et un poste de commande de Navigation, quelques voyants-poussoirs pour le pilote automatique et le train d'atterrissage.

Sur la face verticale de la console, des clefs et potentiomètres réalisent l'interface avec l'ordinateur.

Au-dessus du pupitre, le système de visualisation constitué d'un gros tube couleur à pénétration et balayage cavalier. On dessine sur ce même tube les réticules du collimateur tête haute et ceux de la visualisation tête basse du MIRAGE 2000.

Grâce à la souplesse du logiciel conçu pour modifier les images sans interrompre la simulation, ce système remporte un vif succès auprès des pilotes et des ingénieurs du Bureau d'Etudes Système d'Armes : ils disposent enfin d'un moyen puissant de dialogue entre concepteurs et utilisateurs.

Le temps d'utilisation de la machine dépassant très largement les "heures creuses" de l'ordinateur Essais en Vol, il est décidé de donner son autonomie à ce système qui devient une antenne du Bureau d'Etudes auprès des pilotes. Sa fonction principale lui donne son nouveau nom OASIS (Outil d'Aide aux Spécifications Informatiques des Systèmes).

LE SYSTEME OASIS

Héritier direct de la machine DAISY, il est composé de façon analogue en conservant les mêmes principes.

a) LE MATERIEL COMPREND :. LE CALCULATEUR :

C'est un ordinateur 32 bits identique à ceux utilisés aux Essais en Vol, très bien adapté aux opérations en temps réel.

Le logiciel déjà développé reste utilisable.

A l'unité centrale CPU est adjointe une autre unité IPU capable de travailler en parallèle. Cette disposition permet de diminuer les temps de cycle dans les applications gourmandes en temps de calcul.

Il comporte les périphériques suivants :

- . l'ensemble de visualisation
- . la console pilote
- . une unité de disque 80 Mega octets
- . 6 consoles dont une console système
- . une unité de bande magnétique 45 IPS, 800/1 600 BPI
- . une imprimante
- . un traceur.

LE SYSTEME DE VISUALISATION

Est constitué d'une unité graphique pouvant être reliée à plusieurs types de terminaux de visualisation, tous à balayage cavalier :

- . tube cathodique monochrome
- . tube cathodique couleur à pénétration
- . tube cathodique couleur à shadow-mask.

Le travail de base s'effectue sur tube monochrome au tracé très précis. Toutes les applications utilisant la couleur imposent l'emploi soit du tube à pénétration (scope radar du MIRAGE 2000), soit de tubes shadow-mask pour des simulateurs d'avions civils (EFIS) par exemple.

Il faudra dans un avenir proche pouvoir relier le système à des tubes couleur à balayage télévision.

LA CONSOLE PILOTE

Est une évolution limitée de la machine DAISY. Les commandes de vol sont identiques. Les postes de commande ont pris une position plus conforme à la disposition avion avec le PCA sur la façade verticale.

La série des clefs "ingénieur" permet tout le dialogue courant avec le calculateur : lancement des intégrations, gel de la simulation, initialisations diverses, accélération dans les phases peu intéressantes. Et surtout, en liaison avec la console, ces clefs permettent de faire apparaître tel ou tel réticule, de changer une loi de guidage, d'inhiber une contrainte, de simuler des pannes.

Les potentiomètres peuvent avoir des affectations très diverses ; force et direction du vent bien sûr, mais aussi changement d'échelle d'une représentation synthétique, du gain d'un guidage ou de la taille d'un réticule.

Ce petit tableau de clefs est doté d'une puissance magique, grâce au logiciel conçu pour ces applications très particulières.

b) LE LOGICIEL

Comme sur tout simulateur, un programme acquiert les ordres pilotes qui sont introduits dans la simulation proprement dite.

Ce sont deux programmes indépendants qui sont utilisés ici : ils accèdent à une zone de mémoire commune.

La simulation calcule les réponses de l'avion aux différentes commandes et intègre sa position dans l'espace. Le radar et autres capteurs sont simulés également avec toutes leurs logiques de fonctionnement. Sauf besoin spécifique, les anomalies, brouillages, etc ... ne sont pas représentés.

Les systèmes principaux de l'avion (pilote automatique) sont pris en compte. Enfin le calculateur principal de l'avion est simulé dans toutes ses fonctions liées au système d'armes.

Cette importante charge de calcul a dû être organisée pour respecter un élément primordial en simulation pilotée : le temps de cycle de calcul.

Pour cela la simulation est divisée en plusieurs parties :

- . les macrofonctions
- . la génération des symboles tête haute
- . les générations de symboles tête basse (une par scope)
- . le logiciel graphique.

Les macrofonctions

Simulent différentes fonctions comme pilotage, navigation, radar, AIR-AIR, AIR-SOL avec une macrofonction par type d'arme.

Elles sont appelées à chaque cycle de calcul si elles sont concernées, leur appel ou non est géré par des mots de contrôle.

La Génération de symboles

Elle remplit les fonctions d'un "BGS" (Boîtier Génération de Symboles) à bord de l'avion. Elle assure donc le dessin des réticules de la VTH et de la VTB et gère les limitations du champ viseur : certains réticules sont modifiés en bordure de champ, d'autres simplement limités à l'intérieur du cercle. En VTB les limites carrées facilitent cette gestion.

Chaque réticule est constitué d'un ensemble de vecteurs conservé en mémoire et transféré dans la mémoire de visualisation à la position qu'il doit occuper dans le viseur.

Tout réticule immobile est écrit une seule fois. Sa série de vecteurs reste en permanence dans la mémoire de visualisation ; elle est donc présentée à chaque balayage comme les autres réticules.

Le logiciel graphique de base

- . Il gère la mémoire de visualisation, présente les réticules nécessaires seulement et applique les différentes cadences de rafraîchissement. La limitation de la cadence rapide aux seuls réticules le nécessitant est un facteur intéressant d'économie de temps de cycle.
- . Il effectue les fonctions graphiques élémentaires ; ces fonctions sont généralement prévues dans le logiciel propre au système graphique mais elles ne respecteraient pas le temps de cycle requis en simulation. Il faut donc les réaliser dans l'ordinateur de simulation. On gagne du temps dans ce cas en éliminant une partie des contrôles et tests inutiles dans cette application.

Le logiciel de base qui réalise ces fonctions doit commander plusieurs systèmes graphiques utilisant des codes différents bien sûr. Suivant le système connecté, il appellera le sous-programme correspondant créé à cet effet.

LES UTILISATIONS :

1°- Validation de concepts

Pour le Bureau d'Etudes système d'armes l'utilisation de cet outil est devenue une étape presque indispensable dans le développement d'un système.

Le travail collectif d'élaboration d'un nouveau système d'armes fait appel aux différents spécialistes de la Société, aux fabricants d'équipements et aux utilisateurs.

Lorsque le système prend corps, les concepteurs sont amenés à rédiger un document descriptif assez précis appelé "Modes et Commandes" qui présente la partie matérielle du projet et son fonctionnement (logiciel ...). Les commandes spécifiques au système sont également décrites avec leur utilisation ; c'est en fait la présentation de la philosophie générale d'emploi du système.

Chacun des modes et sous-modes de fonctionnement décrit dans Modes et Commandes fait l'objet d'une description très détaillée dans un document dit de "Spécifications Globales", document réalisé par un spécialiste de la fonction considérée.

Comme les supports matériels de l'interface Pilote-Avion sont de plus en plus des tubes cathodiques, un système informatique avec larges possibilités graphiques est utilisé pour réaliser les symboles proposés.

Avant d'aborder l'étape de la réalisation matérielle et logicielle, les concepteurs sont fortement désireux de lever un certain nombre de doutes sur les modalités d'emploi du système, les types de présentations élaborées, les principes de guidage prévus.

C'est OASIS qu'ils vont utiliser pour réaliser un certain nombre de simulations destinées à provoquer les réactions des utilisateurs sur les principes nouveaux envisagés, les lois ou algorithmes développés, etc ... et finalement à valider le système avant réalisation.

Personne ne se fait d'illusions sur la portée d'une telle "validation" ! La simulation même bien faite ne remplace pas le vol : l'utilisation d'OASIS n'est donc pas une garantie de parfaite réussite du système dès les premiers vols, mais cette étape élimine sûrement une part importante des erreurs de conception et représente donc une économie notable sur le volume de modifications que nécessitera le système.

Il permet aussi un dialogue extrêmement efficace entre les concepteurs et les utilisateurs représentés par le pilote d'essais de la Société, dialogue qui profite aux deux parties pour une meilleure compréhension des problèmes réciproques.

2°- Recherche de figurations nouvelles

De nouvelles idées de figurations sont lancées, souvent par des pilotes, pour améliorer telle ou telle phase de vol, rendre plus facile à analyser une situation délicate ...

C'est le retour aux sources pour OASIS qui continue à assurer ce genre d'expérimentation extrêmement enrichissante.

3°- Avionique civile

Un parallèle assez fidèle peut être fait entre les besoins du B.E. Système d'Armes et celui des avions d'affaire lorsqu'il s'agit de concevoir, d'adapter et de lancer des équipements aussi nouveaux que les EFIS. Grâce à une mise au point rapide de l'interfaçage avec les tubes couleur utilisés sur avion, OASIS est capable de présenter des simulations très réalistes de ces nouveaux "instruments" et bien sûr de permettre leur mise au point rapide grâce à la souplesse d'emploi du système.

4°- Instruction

Cette utilisation paraît évidente, les simulateurs sont généralement destinés à l'instruction. C'est moins vrai pour une machine plus orientée vers l'étude et encore moins vrai sur une système très dépouillé au niveau matériel.

Il s'avère pourtant qu'OASIS est un excellent outil d'instruction car il est très souple, très facile à mettre en œuvre et que plusieurs utilisateurs peuvent profiter de chaque séance, ce qui n'est pas réalisable sur les simulateurs traditionnels.

5°- Confection de manuels pilote

Le graphisme de bonne qualité obtenu sur le traceur permet d'obtenir des "clichés" des réticules VTH et VTB aux instants choisis pendant une phase importante de vol, créant ainsi une "bande dessinée" de ce que doit voir le pilote au cours de cette phase de vol. C'est le principe utilisé pour les planches des manuels pilote. Ces planches étaient difficiles à faire à la main, les paramètres de vol rarement bien corrélés. En quelques minutes la série de tracés est prête à la reproduction.

CONCLUSION

Désirant disposer d'un outil d'étude des cockpits nouveaux situé entre la planche à dessin et le simulateur classique, les ingénieurs d'AMD/BA ont créé un système simple, souple et puissant qui remplit parfaitement son rôle et qui trouve d'autre part chaque jour de nouvelles applications. Les développements en cours d'OASIS sont un peu plus élaborés au niveau matériel mais ils respectent scrupuleusement les règles de simplicité et de souplesse découvertes pendant la mise au point.

Alarmes vocales et commandes à voix commencent leur expérimentation sur la machine OASIS dédiée à RAFALE et bientôt le traitement d'images style télévision sera possible.

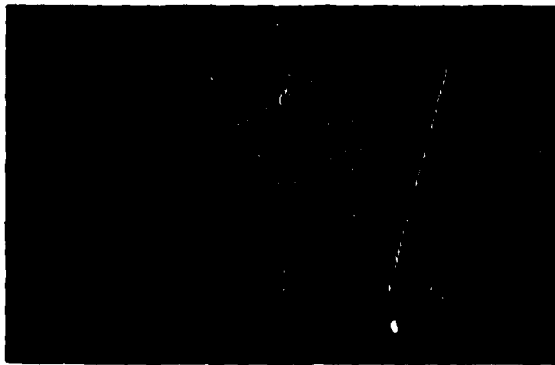
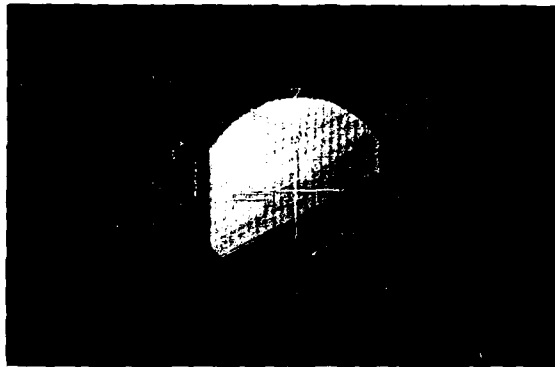
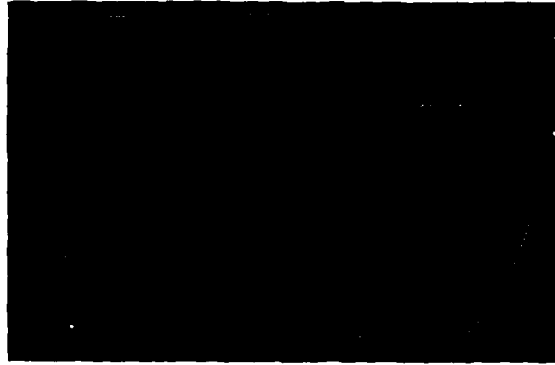

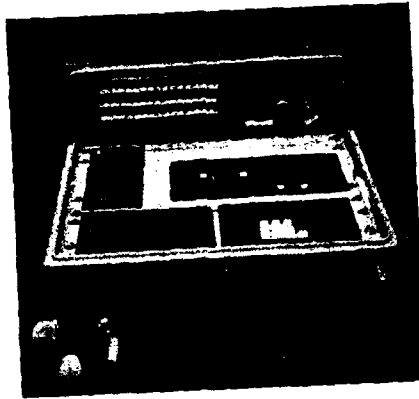

Fig 7



Fig 8



Fig 9

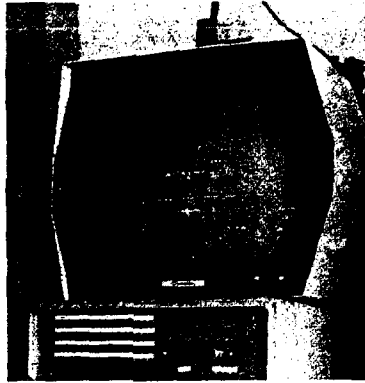

Fig 10



Fig 11



Fig 12



Fig 17



Fig 18



Fig 19

"OASIS" — A MODERN TOOL FOR REAL-TIME SIMULATION

by

J. Benoit
Avions Marcel Dassault-Breguet Aviation
Istres, France

"SIGHT"

It is of prime importance that the fighter pilot has a very good view around his aircraft and over as large a field as possible. Indeed, there is nothing better than the eye for both detection and evaluation of an aerial situation.

Radars, computers and various aids available in modern aircraft supply large amounts of information, but are difficult to interpret and require continuous practice. Use of these aids covers cases where direct vision is impossible. Restoration of this direct view gives the pilot a new range of information: studying the attitude of a hostile aircraft gives him a better appreciation of the "intentions" of his adversary, thus facilitating the selection of the best tactic to employ.

In close combat, a constant view of the enemy is indispensable to avoid losing the "split second" necessary to decide on the best manoeuvre to choose. Having to read the altitude or Mach number on the instrument panel under these conditions may lead to loss of visual contact and perhaps contribute to losing the fight as well.

It is thus easy to understand the pressure exerted by pilots to lessen these drawbacks by having major flight information shown on *head-up* displays.

From the end of World War II, only weapon-firing symbols were processed and displayed to the pilot as a projection on the outside world. As long as the cues were being displayed by electro-mechanical means only a limited amount of flight information could be made available. Not until the introduction of Cathode Ray Tubes (CRTs) to generate symbols was there a rapid development of the *aiming sights* and then of cockpit arrangements.

"GLASS" COCKPITS

Use of CRTs is not as new as all that, however. Radar scopes began to be seen in cockpits in the sixties. At that time, however, their brightness was too low for a fighter cockpit environment and sizeable "hoods" had to be fitted. The introduction of new weapons requiring great flexibility in adapting to changing operational requirements has also led to an increasing variety of uses of CRTs.

Moreover, the principle of displaying information only when necessary allows for a "time-sharing" arrangement of the sighting head areas available in the cockpit.

As a result, the number of CRTs increased as the quantity of the old electro-mechanical instruments decreased. At the same time, cockpit design has changed radically. Instead of dealing with the location of *instruments*, with the development of new equipment tailored to the new requirements, and with specialised control panels, cockpit designers now have to create living images which evolve for optimum use in each progressive flight phase.

DEVELOPMENT OF IMAGES

Image processing is an established subject, dealt with in numerous systems. Our present concern, however, is to enliven images — to animate them in the way that they will move during a flight to ensure from the outset that they will adapt well to the functions for which they were designed. The solution to this problem is well-known: it is the flight simulator.

Unfortunately, the equipment is very expensive and is consequently not widely used, nor is it available for very topical experiments. Moreover, this equipment is not sufficiently adaptable to preliminary research work, neither for hardware nor for software engineering. Effective comparison of symbologies is dependent upon the ability to introduce rapid modifications. At a few minutes' interval it is easy to compare two solutions in detail, whereas this comparison loses a great deal in accuracy once a few days have elapsed.

The system developed by AMD-BA greatly simplifies the hardware part of the simulator and thereby leads to a considerable price reduction.

DAISY MACHINE HISTORY

(Dispositif d'Animation d'Images Synthétiques/Synthetic Image Animation System)

The initial approach to the system was concerned almost exclusively with the software. Working on the simulator during Flight Test computer "free time", a rough Mirage 2000 simulation was used to enliven HUD and HDD symbols shown on a colour penetron CRT, enhanced by a graphics system. The pilot's interface was a console with a reprogrammable keyboard.

The animation was close to reality but "push-button flying" was a tedious affair. A remote control mini-stick improved this, but showed up the need for easy access to the weapon controls and more especially those which in the aircraft would be located under the pilot's fingers.

Despite its deficiencies, this tool proved very useful for simultaneous discussion between several users, about the location of the symbols and the type and size of the digits, for instance. It also proved to be a particularly efficient and well-received instructional tool.

Design of a more functional interface was then decided upon; a Mirage 2000 pilot's stick and power lever were fitted to mountings added to the frame of a conventional console and keyboard unit. Both the control stick and the power lever carry all the usual controls (trim actuators, switches, knobs, etc...). The articulated power lever moves and controls a potentiometer, and the very short, limited travel control stick restores "feel" to the controls similar to that experienced on the aircraft. Rudder pedals are not provided as they are only needed in actual flying (decrabbing, heading and aiming corrections).

The console also carries a simplified radar control panel, a weapon control panel, the exact reproduction of the aircraft mounted WCP, a navigation control panel and annunciator push-buttons for the auto-pilot and the landing gear. The vertical panel of the console carries keys and potentiometers to provide an interface with the computer.

A large colour penetron cathode ray tube, enhanced by a stroke writing system, is located above the console assembly to display both Mirage 2000 HUD and HDD symbologies.

Thanks to the flexibility of the software, which is configured to allow symbology modifications without interrupting the simulation in progress, the simulation facility has become very popular amongst pilots and weapon-system design engineers who, at last, have a very powerful tool to facilitate the dialogue between designers and users.

The operation of the machine now greatly exceeds the "free time" of the Flight Test Centre computer: for this reason it was decided to allow the simulator to be run autonomously, as an extension of the Design Offices, for the benefit of the pilots. Its name was determined by its main function: OASIS (Systems Software Specification *Design Aid*).

THE OASIS SYSTEM

This system is a direct descendant of DAISY; it is a similar concept based on the same principles.

a. HARDWARE

The hardware comprises:

THE COMPUTER

This is a 32-bit machine, identical to those being used by the Test Centre and well suited for real-time operation. The same software is used. An IPU is added to the CPU for parallel operation: this arrangement allows a cycle-time reduction for time-consuming processing.

Peripherals – these include:

- One display unit
- One pilot console
- One disk unit with 80 megabyte capability
- Six consoles with one system-console
- One magnetic tape recorder unit with 45 ips – 800/1600 BPI capability
- One printer
- One tracer

VISUALISATION SYSTEM

This unit can be connected to several display terminal types, all with stroke writing:

- One monochrome CRT
- One colour penetron CRT
- One shadow-mask colour CRT

The basic work is done on the monochrome CRT on which tracing is very accurate. If colours are required either the penetron CRT (Mirage 2000 radar scope) or shadow-mask CRTs (EFIS, for instance, for civil aircraft) have to be used.

This unit will be connectable to colour raster-writing CRTs in the near future.

PILOT CONSOLE

This is a minor improvement over the DAISY machine. Flight controls are the same. Control panel locations are now almost identical to aircraft stations, with the weapon controls on the vertical panel.

An array of "engineer keys" allows "live" interaction with the computer for: initialisation of integrations, freezing of simulations, various inputs, and acceleration of phases of little interest. Most important, these keys in conjunction with the console, allow one to display a particular symbol, change a guidance schedule, inhibit a constraint, or simulate failures.

The potentiometers provided may be used for various functions: modification of wind strength and direction, of course, and also change of scale of a synthetic representation, gain of a signal, or size of a symbol.

In a way, one could say that this key panel has a "magic power", provided by its software and designed to meet all these specific requirements.

b) **SOFTWARE**

As with all simulators, the software processes pilot commands which are introduced into the simulation in progress. In fact, this program comprises two independent sub-routines with access to a common memory.

The simulation software computes the aircraft's response to the various commands and integrates its position in space. Radar and other sensors, and all their operation logics, are also simulated and integrated. Failures, interference, etc. are not represented, except when specifically required. The main aircraft systems (autopilot etc.) are also represented in the simulations. Finally, the main aircraft computer and all its functions connected with the Nav-Attack system are also part of the simulation concept.

This heavy calculation load had to be arranged in such a way that the prime flight simulation criterion of computation in a real time frame was strictly respected. For this reason, simulation had to be split into several parts:

- Macrofunctions
- HUD symbols generation
- HDD symbols generation (one per screen)
- Graphics software.

Macrofunctions

These functions simulate piloting, navigation, radar, air-to-air and air-to-surface firing, with one macrofunction per weapon type. They are called into each computation cycle as and when required by means of control words.

Symbols Generation

The generator provided has the same functions as the aircraft SGU (Symbols Generation Unit); it ensures the display of both HUD and HDD cues, and monitors the boundaries of the field of vision. Some symbols are modified when approaching the limits of the field of vision and others are limited to the inside of the display circle. In HDD operation, square-shaped limits facilitate this management process.

Each symbol consists of a set of vectors stored in memory and transferred by the display unit memory to the location visualised in the collimator. Any motionless symbol is written only once; its set of vectors remains permanently in the display unit memory to be visualised at the same time as all the other symbols during each scan.

Basic Graphics Software Functions

Management of the display unit memory to call in only the symbols required and to apply the various rates of renewal. Selectively limiting the rapid rate to those symbols which require it gives greater economy of cycle time.

Performance of elementary graphic functions

These functions are normally provided by the graphic system's own software but they would not meet the cycle-time requirements imposed by simulation. It is therefore necessary to have them processed by the simulation computer. In this case, time is gained by eliminating some of the checks and tests not needed for this particular task.

The basic software performing these functions must be capable of controlling several graphics programs by using various codes. Depending on the graphics program in use, it calls in the appropriate sub-routine for this purpose.

USES

1. Validation of Concepts

This tool is now practically indispensable to the Nav-Attack Systems Designers when developing a new system. The creation of such a system is the result of cooperation between AMD-BA specialists, equipment manufacturers and the users.

When setting up a Nav-Attack system, the designers write a relatively detailed descriptive document called "*Modes et Commandes*" (*Modes and Controls*), setting out the hardware layout of the project and its operation (software). Specific controls are also described in detail, together with their operation. This document presents the general philosophy of the system.

A very detailed description of each mode and sub-mode listed in the document "*Modes et Commandes*" mentioned above is given in another document called "*Spécifications Globales*" ("*Overall Specifications*") which is written by a specialist in each of the functions under consideration.

As pilot-aircraft interface hardware relies increasingly on CRTs, a data processing system including wide-ranging graphics capabilities is being used to present the proposed symbols.

Before engaging in hardware and software engineering, designers need to make sure of a number of elements such as system operation schedules, the type of symbology and display adopted and the *planned guidance principles*. To facilitate their task, designers use OASIS for a number of simulations the objective of which is to find out how the end users will react to the challenge of new principles, schedules, algorithms, etc... and eventually to "validate" system specifications before launching production.

Of course, nobody has illusions about the relevance of such a "ground validation", however carefully and skilfully designed! Simulation, even of outstanding quality, can in no way replace actual flight testing. Thus, the use of OASIS does not constitute a full guarantee of success of the system right from the first flight, but this intermediate step doubtless eliminates a significant number of design errors and therefore considerably reduces the number of modifications necessary at a later stage.

The simulator also allows an extremely efficient dialogue between designers and end users, the latter being represented by the aircraft manufacturer's test pilot, and this exchange is beneficial for a better mutual understanding of each other's problems.

2. Research on New Symbology

New ideas on symbology are suggested, often by the pilots themselves, to improve a particular flight phase or to simplify the analysis of a tight situation, etc. This is a return to basics — to the primary purpose of OASIS which is to continue to maximise the effectiveness of this experimental work.

3. Civil Aircraft Avionics

There is a parallel between the needs of both Weapon Systems and Civil Aircraft designers in the conception, adaptation and launching of equipment as new as EFIS, for instance. As a result of the progress in the interface with colour CRTs in aircraft, and because of its high degree of operational flexibility, OASIS can offer very realistic simulations of this new instrumentation and promote its rapid development.

4. Training

The purpose of instruction is of course obvious and it is what simulators are mostly used for. However, this is less true for a machine designed primarily for development work — and even less for a tool whose hardware is kept to a strict minimum. Nevertheless, OASIS is proving to be an excellent training aid too, because of its versatility and ease of operation and because it can be run for several users, a capability which conventional simulators do not offer.

5. Writing Flight Manuals

The high quality of the graphics on the tracer means that prints can be made of the HUD and FID symbols at selected instances during an important flight phase. These can be assembled like a strip cartoon to show what the pilot will see in flight. This principle is used for the illustrations in flight manuals since hand-drawn symbology sequences were difficult to prepare and seldom correlated with flight parameters. Instead, hard copies giving the required degree of accuracy can be ready for reproduction within a few minutes.

CONCLUSION

AMD-BA engineers wanted a design tool to fill the gap between the drawing board and the traditional simulator for the development of new cockpits. Their solution was to design a simple, flexible and powerful system for which new applications are frequently being found. Although the process of development has introduced substantial improvements, OASIS has retained its fundamental design principles, namely simplicity and flexibility. For the future, experiments are currently being undertaken with voice commands and alarms on OASIS for the Rafale fighter, and TV-image processing will soon also be possible.

SIMULATOR MOTION CHARACTERISTICS AND PERCEPTUAL FIDELITY

A Progress Report

by

B.N. Tomlinson

FS(B)3 Division, Royal Aircraft Establishment, Bedford MK41 6AE, UK

SUMMARY

This Paper is a progress report on a Study, commissioned by the AGARD Flight Mechanics Panel, to review existing data and try to describe a relationship between certain motion system parameters, identified in an earlier AGARD Report (AR-144), and the fidelity of the pilot's perception of flight. Motion system characteristics as a whole are discussed, thus extending AR-144's treatment of motion mechanisms to include motion drive software and other features. Some of the key parameters of AR-144 are then examined in relation to total motion system fidelity. Finally, some proposals are made for a common format data structure with which to summarise research results on motion cues. The study is continuing.

1 INTRODUCTION

This Paper is a Progress Report on a Study, commissioned by the Flight Mechanics Panel, entitled "Simulator Motion Characteristics and Perceptual Fidelity".

Prior to the current work, a series of AGARD Advisory Reports^{1,2,3} had examined various facets of simulation. While these Reports are probably well known to the simulation community, they are listed here for easy reference.

Background Documents - AGARD Advisory Reports

- AR-144 (1979) Dynamic Characteristics of Flight Simulator Motion Systems
FMP WG-07
- AR-159 (1980) Fidelity of Simulation for Pilot Training
AMP/FMP WG-10
- AR-164 (1981) Characteristics of Flight Simulator Visual Systems
FMP WG-10

The first of these, AR-144, described how to measure motion system quality under five major headings:

- excursion limits,
- describing function,
- linearity and acceleration noise,
- hysteresis
- and dynamic threshold.

It was concerned solely with platform-type motion systems, and treated the motion mechanism purely in terms of its ability, as a piece of hardware, to reproduce the demands made upon it. What the Report did not include, quite deliberately, was any consideration of the motion drive software, and how motion cue demands are actually generated. This topic is now being included in the present work.

The second Report, AR-159, examined simulation for pilot training, and struggled unsuccessfully to define what level of perceptual fidelity was needed to achieve satisfactory training. While this is still a major, but unanswered question, AR-159 did identify several issues related to motion cues, including a concern about a shortage of generalizable data to define the perceptual cues needed to train pilots, and the lack of a 'model' of motion utilisation for simulation.

The third fidelity-related Report, AR-164, is mentioned here for completeness. It described the variety of physical parameters that characterise a visual system and determine its fidelity, and thus did for visual systems what AR-144 had earlier done for motion.

With these Reports as background, and with the still unresolved questions concerning what motion fidelity is required to train pilots, the Flight Mechanics Panel commissioned the present Study,

"to review existing data with the objective of defining the effect of simulator motion system characteristics on perceptual fidelity".

The Pilot Paper that instigated this work called for it

"to describe the effects of AR-144's parameters on the pilot's perception that he is flying the real-life aircraft in the realistic situation".

Specifically, it should extend the earlier work embodied in AR-144 and be concerned with the motion cues, not just the motion hardware. The wider scope is necessary, as it is well known that the same hardware can produce better cues merely by software changes.

Motion cues are generated by a combination of software and hardware. The primary role of motion software is to transform the aircraft's dynamic response (linear and angular accelerations) into demands that may legitimately be met by a particular motion mechanism, bearing in mind its intrinsic performance limitations. Combining the drive software with the hardware mechanism leads to a complete definition of a motion system and it is in this 'complete' sense that a motion system will be treated in the rest of this paper.

The statement that a motion system reproduces a set of motion stimuli, which are perceived by the pilot through a variety of sensory pathways, prompts two major questions. These are

1. How should the drive algorithms, embodied in software, be described to complement the definitions of AR-144, and thus make the pilot's motion cue environment fully known?
2. How does the pilot's subjective assessment of the fidelity of what he perceives depend on these characteristics of the complete motion system?

With these questions in mind, the Study is intended to try to establish an engineering relationship between motion system features and their effects on the pilot, and thus point the way to answer AR-159's appeal (S2.4, p11) for better models of motion utilisation. The Study will, however, explicitly avoid the question of how much perceptual fidelity is needed to train.

The Study was begun by Dr Greg Zacharias, then of Bolt, Beranek and Newman in the USA and now of Charles River Analytics Inc. The author joined in to provide some support from the European end, and now Dr Zacharias has had to withdraw owing to pressure of other commitments.

An initial examination of the task suggested a plan of attack with several phases:

1. to define how motion characteristics, in the full sense of a cue generation system, should be described and recorded,
2. to define relationships between motion characteristics and aspects of simulation fidelity,
3. to examine published literature as the main source of information, categorising the data by aircraft type, flight task etc,
4. to establish how best to summarise available data in a structured way, to be given the name Common Format Database.

It was soon clear that what should be done was not necessarily what could be done by two people with limited resources. The plan was therefore reduced, particularly in the area of the literature search and summary, to consideration of one or two combinations of aircraft type and flight task, with the limited objective of demonstrating the application of the proposed data summary structure, for others to continue.

This Paper, in reporting on progress so far, will outline current thoughts on defining motion system characteristics, on some key parameters affecting motion system fidelity and on how to categorise the literature.

2 MOTION SYSTEM CHARACTERISTICS

A first step in considering motion characteristics as a complete system is to examine motion (and visual) cues in a simplified simulator control loop, as drawn in Fig 1. The response of the aircraft feeds the motion and visual systems which in turn produce the cues that stimulate the pilot to react with movements of his controls. Closing the loop causes the aircraft to respond to the control movements.

In this Paper, the motion system is of principal concern. Fig 1 expresses the complete relationship between the aircraft response variables and the received (not necessarily perceived) cue stimuli. In more detail, Fig 2, the motion system consists of a cue generation phase (sometimes also known as the motion logic), the motion drive phase (generating the command inputs to the servo system) and of course the actual hardware. AGARD Report AR-144 only dealt with the hardware, ie with how to ensure (or measure if) the hardware mechanism responds crisply and smoothly to the demands placed upon it. Quite deliberately, the Report did not deal with the nature of those demands, which will now be examined.

2.1 Motion cue generation

Fig 2 separates motion demands feeding the hardware into a cue generation part and a drive part, both of which are assumed to be embodied in software.

There is no generally agreed format to define algorithms to generate motion cues, or even an agreed name: motion logic or washout being alternatives. As outlined in the Introduction, one of the aims of the present Study is to make some proposals in this respect.

Driving a complex motion system can be quite involved. Platform axes have limited displacements and other performance constraints, so aircraft motion demands must be attenuated in some way, which is a typical role for filters. It is also necessary to coordinate rotations and translations to provide the pilot with coherent and useful cues.

To simulate forward acceleration, for example, a motion platform will first surge forwards and then, while returning to its neutral position, the cockpit will tilt up. The forward surge provides the onset and the subsequent tilt the steady state effect of sustained acceleration (within the angular limitations of cockpit tilt).

A much-simplified structure for a cue generation algorithm is shown in Fig 3. Inputs from the aircraft model are three angular acceleration components and three components of specific force. The latter is the usual form of linear acceleration employed in motion systems.

The structure shows two 'direct' paths, one from angular acceleration inputs via a filter to the rotational axes and the other from specific force inputs also via a filter to the translation axes. The filters commonly used are linear second-order high-pass filters, which serve to attenuate low-frequency demands to keep excursions within the available envelope. These filters are also termed 'wash-out' filters. Some direct attenuation of accelerations may be necessary, via input gains. Alternative non-linear schemes are sometimes employed⁴.

Two 'cross' paths are also shown in Fig 3. Low-pass filtering of specific force produces long-term demands which are satisfied, as far as X and Y components are concerned, by tilting the cockpit in pitch and roll. No technique exists to do the same for Z. The other path commands translational accelerations to coordinate with angular demands and to counter false tilt sensations due to cockpit pitch and roll.

A further role for the cue algorithm is to apply a 'limit logic' to keep the motion mechanism off its stops and to allow a smooth recovery from any saturation of demands. This is properly included in the cue generation part because it can influence the real cues, especially if the limit function starts well away from the end stops.

Definition of cue generation methods is intended to provide information about what motion stimuli were actually provided in an experiment. Unfortunately, while many reports show that making some change to the simulator's motion characteristics produced an effect on pilot behaviour, few define precisely what effects the change had on the reproduced motion. It is essential that what the motion was doing be described.

To satisfy this need, all the information mentioned above in relation to Fig 3 could be defined in detail, on lines similar to AR-144. A list is given in Table 1. Definition of 10 describing functions is needed, to provide amplitude and phase information versus frequency for the 6 'direct' and 4 'cross' paths. The axes relationships required are shown below.

Describing Functions Required to Define Motion Cues for 6 Axes

		Outputs					
		X	Y	Z	ϕ	θ	ψ
Inputs	X	✓				✓	
	Y		✓			✓	
	Z			✓			
	ϕ		✓		✓		
	θ	✓				✓	
	ψ						✓

plus some reassurance that cross-axis excitations, eg $\theta \sim Z$ are zero.

A simpler approach may be to adopt the concept of 'recovered' motion. The purpose of low or high-pass filtering and of coordination illustrated earlier in Fig 3 is to use the motion mechanism to best effect and to exploit some of the known features of the human being's sensory response. 'Recovered' motion is what is actually reproduced at the pilot's station in the simulator and may be compared with the situation in the 'real' aircraft in terms of angular accelerations and specific force (as measured by an accelerometer).

For example, in simple terms

$$\ddot{X}_{\text{recovered}} = \ddot{X}_{\text{cockpit}} + g \sin\theta_{\text{cockpit}}$$

Thus recovered \ddot{X} conveniently re-combines those parts that were deliberately split in the cue generation algorithm, and only 6 describing functions would be required.

2.2 Motion hardware

The other major part of the complete 'motion system' is the hardware itself. In concentrating on the engineering parameters of motion hardware, AR-144 recommended five features to characterize motion system dynamics. These are:

1. excursion limits for single degree of freedom operation,
2. describing function,
3. linearity and acceleration noise,
4. hysteresis,
5. dynamic threshold.

Techniques to measure these features were outlined by the Report, and some experiences in applying them to real motion hardware are described elsewhere at this Conference⁵.

No numbers associated with the characteristics were included in AR-144. Indeed, the Report concludes explicitly

"The Working Group has not set standards of acceptability for any of the measured characteristics. Further work (should) be done to set such standards."

Items 1, 2 and 5 above are central to the generation of cues, while the other two are more concerned with deficiencies and unwanted effects, such as reversal bump and smoothness (or lack of), which may detract from the realism otherwise generated.

How do these central measures affect fidelity? Each will be discussed briefly.

Excursion limits

The system limits, defined in AR-144 as 'the extremes for displacement, velocity and acceleration which can be reached during controlled single degree of freedom operation' are often shown in a performance diagram of velocity (linear or angular) plotted against frequency. Displacement and acceleration limits can also be shown, as in the typical case illustrated in Fig 4. This is a useful way to convey the size of cue that can be reproduced and the limits inherent in the design of a motion mechanism.

It is generally true, as is also apparent from Fig 4, that for the frequency range of interest to studies of aircraft short period dynamics, maximum velocity is the key limiting factor, rather than displacement or acceleration. The extent of this velocity-limited region is set by mechanical constraints, such as hydraulic flow rate.

If a motion system is to be used effectively, while avoiding the velocity limit, then accelerations near maximum can only be generated at relatively high frequency. At lower frequencies, when nearly full travel is used, only low accelerations can be generated before the velocity limit is the main constraint. These effects are illustrated in Fig 4 by the dotted lines.

Some motion performance diagrams for actual simulators are shown in Fig 5a&b for heave and roll response. The simulators referred to are:

- A. NASA, Langley Research Centre
Visual Motion Simulator
6-leg synergistic
Source: Ref 6

This is a tuned-up commercial motion system and so could be taken as representative of the best that a training simulator might achieve.

The remainder are special-purpose research simulators of various kinds, and illustrate the range of facilities available.

B. NASA, Ames Research Centre

Vertical Motion Simulator
 Large amplitude vertical and horizontal translations
 Synergistic system (currently) for rotations
 Source: Ref 7

C. NLR, Amsterdam

Four degree-of-freedom
 Hydrostatic actuators
 Source: Ref 8

D. RAE, Bedford

Five degree-of-freedom
 Large amplitude vertical and horizontal translations
 Under construction in 1985.

From these illustrations, it is clear that no simulator has managed to escape the inhibition of velocity limits, with their associated impact on motion cue fidelity.

System limits show the maximum performance possible. Practical, usable limits are shown by the operational limits, at which the acceleration noise ratio reaches prescribed values. Measurements of these characteristics are needed for a variety of simulators, so that a relationship with perceptual fidelity can be established. At present, not enough is known about 'acceptable' levels of noise, which embraces general random noise as well as distortions such as reversal bumps.

Describing function

The describing function defined in AR-144 is the 'sinusoidal input describing function' commonly used for non-linear systems and is employed as a more general way of giving amplitude and phase information as a function of frequency. For only slightly nonlinear systems, the describing function may be considered as representing the transfer function of a linear system, and describes the dynamics of the servo loop controlling the motion system. When added to the performance diagram of Fig 4, an additional boundary intrudes at the high-frequency end of the plot, to constrain the frequency range over which cues can be reproduced. This will be discussed again later.

Dynamic Threshold

The dynamic threshold is defined in AR-144 as the time required for the output acceleration to reach 63% of the input acceleration command, and combines lag due to the dynamics of the system with threshold effects. Typical numbers illustrated in AR-144 for real systems are 50-100 m sec.

3 TOTAL MOTION SYSTEM FIDELITY AND SOME KEY PARAMETERS

The effect of the high-pass (or washout) filters, mentioned earlier as being a fundamental part of cue generation, can also be shown on the motion performance diagram. It appears as a new boundary at the low-frequency end (Fig 6). Thus with the washout at one end and the servo system at the other, the frequency band within which the total motion system operates is much constrained compared with the nominal boundaries set by excursion limits alone.

3.1 Phase requirements

The motion performance diagram concentrates on amplitude effects. Of equal (if not more) importance from the pilot's point of view is the phase relationship between the motion cues he feels and those the simulated aircraft actually generates. This is determined by the balance between the washout filter, that generates phase lead distortion, and the servo system which generates phase lag. If a sufficient margin can be maintained between the washout filter frequency and the servo break frequency then there will be a frequency band in which the phase distortion of the pilot's motion cue will be acceptably small.

Bray has suggested (Ref 9) that for a high degree of subjective fidelity, this phase distortion should be kept between 30° lead and 30° lag. With this criterion, the valid frequency band can be determined, if it is assumed that the servo system can also be represented as a second order filter. At the break frequency of a second order system, the phase shift is, of course, 90°, so the high fidelity range to satisfy the 30/30 criterion is much less than the difference between break frequencies. This is illustrated in Fig 7, for several values of washout and servo frequency. Each case has its break frequency shown as a heavy dot, and the frequency range for which the phase is less than 30° lead (for washout) or less than 30° lag (for the servo) as an open box.

In a given system, with a known servo characteristic (AR-144's describing function), washout and servo effects can be combined. Some resulting 'fidelity bands' are shown in Fig 8, for three values of washout filter frequency (0.2, 0.6 and 1.8 rad/sec) and two values of servo break frequency (30 and 10 rad/sec; representing a good and an average

system). With a high servo frequency and a low washout filter frequency, a broad fidelity band results, spanning a typical range of aircraft short period dynamics (1 sec to 10 sec period). As the washout frequency is increased, the fidelity band shrinks significantly. The three cases shown shaded can be described as representative of high, medium and low fidelity, respectively. With the low servo frequency (10 rad/sec), the fidelity band is still reasonably good for the lowest washout frequency, is dramatically cut with the middle washout and vanishes for the high washout frequency.

Experience at NASA Ames⁹ suggests that pilots are more tolerant of motion constraints in vertical (heave) motion than in rotational axes, where a strongly sensed motion-visual disparity may arise if washout filter frequencies much above 0.7 rad/sec are used.

3.2 Amplitude requirements

It is now worth returning to the amplitude dimension of fidelity. For a washout filter of second-order high-pass form, a fundamental relationship is that

$$\frac{\text{displacement (X)}}{\text{acceleration (A)}} = \frac{\text{static gain (K)}}{(\text{washout frequency (w)})^2}$$

which expresses the fact that, in the absence of any higher order filtering, a constant acceleration demand will produce a steady displacement. The static gain should, ideally, be close to unity. Inverted, this relationship becomes

$$\frac{A}{X} = \frac{w^2}{K}$$

For a low value of washout frequency, such as has been shown above to be needed for high phase fidelity, A/X is also low, which means that only a low amplitude of acceleration could be reproduced with high phase fidelity.

A large excursion motion system (large X) will help, since A is proportional to X. To be able to cope with a reasonable value of A calls for a higher value of w, or a lower static gain, or both. Fig 9 shows A/X plotted against w for several values of K. With w = 0.2 and a gain of 1, A/X = 0.04, so that a motion system having 2 metres (say) of travel, can reproduce an aircraft acceleration A of only 0.08 m/s², below the threshold of perception. Cutting K to 0.2 means that the aircraft demand acceleration can rise to 0.2 m/s², but the reproduced acceleration is unchanged. This is because

$$KA = w^2 X$$

and KA is what the pilot actually feels. Raising w to 0.6 rad/s increases A/X to 0.36, allowing 0.72 m/s² (still less than 0.1 g) to be reproduced with 2 m of travel.

Taking into account both phase and amplitude effects, fidelity of reproduction must be a compromise. How the balance should be struck is a subject for experiment.

Bray has conducted some suitable experiments, reported elsewhere⁹ and also at this Conference¹⁰, which have produced evidence of the effect of changes in motion cue parameters on subjective fidelity for helicopter hover. Reduction in heave cue fidelity for the base-line helicopter had only a small effect⁹, but for a helicopter with degraded collective response, pilot ratings were much worse with tightly constrained motion than with high fidelity motion.

3.3 Total system delays

Having discussed some aspects of fidelity in relation to amplitude and phase, the next topic to consider is total system delay. For the hardware, this is defined by AR-144 as dynamic threshold. As far as the complete system is concerned, Fig 10 illustrates the contributions to the delay in generating motion cues. A pilot control input occurs between sampling intervals, and on average is assumed to be mid-way between time frames. Calculation of the aircraft's response to the pilot's input can produce acceleration and velocity one frame later and, depending on the numerical integration technique used, position one frame later still, making a total software - dependent delay of 2 1/2 time frames. For an iteration rate of 30 Hz, a time frame is 33 m sec so that the delay is 83 m sec. Add to this a motion lag of 50-100 m sec and the overall delay between control input and motion cue stimulus introduced by the simulator is 133-183 m sec.

If the servo drive technique for the motion system uses a signal other than position demand, then the delay can be reduced but can never be less than the sum of 1 1/2 time frames plus the motion lag itself, say 100 ms. This was pointed out in AR-159, which suggested that reducing the computer frame time could cut the overall delay more easily than improving the motion system lag itself. Poor choice of integration method can increase the delay unnecessarily.

4 INFORMATION SOURCES

Having outlined above some of the key parameters, some experimental data is now required. Information is being gleaned by a careful survey of the published literature and by contact with researchers in various organisations. A literature survey is not always as helpful as it might be, as it is too easy to be overwhelmed by the mass of reports. Filtering is necessary. One form this can take is to rely on the expert practitioners. Some help from this direction has been obtained, more is needed. The challenge is to define a short list of particularly useful and interesting papers on the value of motion cues. More submissions are required and requested.

Once some useful papers have been identified, it is necessary to collate the information they contain. Here it is clear that papers vary enormously in how they present their data. Comparison is difficult without some means to relate one set of tests to another. This is where the proposed Common Format Database Structure comes in.

There are two parts to this database structure: motion-specific factors and the complementary, non-motion aspects. What is needed to describe a simulator's motion cues has already been discussed, and suitable information categories have been listed in Table 1. A format for the second part is shown as a list of headings in Table 2.

As it is well known that discussion of the value of motion cues must include detailed definition of the aircraft type and the flight task being simulated, these headings have received particular attention.

Flight task is split, in Table 2, into

Context: airline, general aviation, military training, ...
 Flight phase: taxi, take-off, climb, ...
 Specific flight task: hover, air-to-air, terrain following, ...
 Task objective: detailed and precise definition of what
 the pilot is to achieve.

Table 3 complements the categorisation in Table 2 with an extensive list of phases and tasks culled from AR-159. Task objective requires description, because pilot gain, and his demands on motion cues, will differ, for example, whether he is instructed 'to hover near that tree' or 'to hover 100 ft from a heli-pad on a ship, maintaining height and position to within ± 2 ft'. This recalls the strong requirement expressed by Cooper and Harper (Ref 11) that when asking a pilot for a handling qualities rating, a clear briefing must be given.

A list of papers has been compiled, and some are being analysed, to produce a data summary using the database structure defined in the Tables. From a limited review of the literature, it is clear that many papers do not describe the motion cue environment in adequate detail, nor the complete experimental context. Ref 12 is one of the few Papers to recognise the number of experimental variables that can be involved.

5 CONCLUDING REMARKS

A complete motion system consists of cue generation and motion drive techniques (embodied in software) and a motion hardware mechanism. How to document the behaviour of the hardware has been defined by AGARD AR-144. Extending this description to the complete motion cue environment is possible and desirable. How it could be done has been suggested. This should include information about what cues the pilot actually experienced, not just statements that tests were conducted with/without motion, or even that a certain parameter was given values of 1.0, 0.5 and 0.0.

A list of informative papers is being collected, partly by conventional literature search techniques and partly by expert recommendation. More contributions are sought. A limited review of some of these papers shows that many research reports do not describe in sufficient detail either the motion cue environment or the whole experimental context. These deficiencies make it difficult to generalise the results. The situation would be improved by adopting a uniform approach to defining and documenting motion (and other) cues and a structure for a common format, with a long list of headings, has been proposed.

Analysis of selected papers is proceeding which, it is hoped, will reveal whether there is a 'body of literature' from which evidence on the effect and value of motion cues can be extracted and generalised, or whether there is just a collection of disparate results. Some examples of such analyses using the common format structure will be included in the final Report.

Some relationships between the principal parameters of AR-144 and some cue fidelity parameters have been suggested. More carefully-controlled and well-documented experiments on motion cues and perceptual fidelity are needed. As long ago as 1970, at another AGARD Conference on simulation, it was remarked¹³ that pressures to perform application studies prevented major research simulators from conducting some motion cue experiments. This situation is still not unknown today.

The work of this Study is continuing, with a final Report due in 1986. Comments and contributions will be welcome.

REFERENCES

- 1 "Dynamic characteristics of flight simulator motion systems". AGARD Advisory Report AR-144 (1979).
- 2 "Fidelity of simulation for pilot training". AGARD Advisory Report AR-159 (1980).
- 3 "Characteristics of flight simulator visual systems". AGARD Advisory Report AR-164 (1981).
- 4 R.V. Parrish and D.J. Martin: "Comparison of a linear and a nonlinear washout for motion simulators utilising objective and subjective data from CTOL transport landing approaches". NASA TN D-8157 (1976).
- 5 K.J. Staples, W. Love and D. Parkinson: "Progress in the implementation of AGARD AR-144 in motion system assessment and monitoring". AGARD FMP Symposium on "Flight Simulation", Cambridge (1985).
- 6 G.L. Ricard et al: "The effects of various fidelity factors on simulated helicopter hover". NAVTRAEQUIPCEN IH-321 (1981).
- 7 D.L. Key et al: "Helicopter simulation validation using flight data", Paper 15. AGARD CP-339 (1983).
- 8 W.P. Koevermans and C.J. Jansen: "Design and performance of the four degree-of-freedom motion system of the NLR flight simulator", Paper 17. AGARD CP-198 (1976).
- 9 R.S. Bray: "Experience with visual and motion cueing in helicopter simulation". FAA Conference on Helicopter Simulation (1984).
- 10 R.S. Bray: "Visual and motion cueing for helicopters". AGARD FMP Symposium on "Flight Simulation", Cambridge (1985).
- 11 G.E. Cooper and R.P. Harper: "The use of pilot rating in the evaluation of aircraft handling qualities". AGARD Report 567 (1969), also NASA TN D-5153 (1969).
- 12 M.L. Cyrus: "Motion systems role in flight simulators for flying training". USAFHRL-TR-78-39 (1978).
- 13 R.S. Bray: "Lead discussion on Paper 4 "Motion, visual and aural cues in piloted flight simulation" by K.J. Staples. AGARD CP-79-70 (1970).

Table 1DEFINITION OF MOTION CHARACTERISTICSSystem Features

Motion mechanism: synergistic, independent axes, beam-type
 Axes available/used

Cue generation

Washout (scaling and frequency content)
 Direct path (high frequency)
 Long term specific force (low frequency)
 Coordination or lack of - cue mismatch
 Linear/non-linear
 Limit logic

Motion drive

Compensation for computational delay
 Compensation for delays/lags in hardware
 Primary servo drive signal (acceleration, velocity, displacement)

Hardware (largely based on AR-144)

Excursion limits
 System/operational for single degree of freedom
 Effect of concurrent axes movements, particularly for synergistic type
 Describing function (frequency response)
 Linearity and acceleration noise (measures unwanted cues, such as roughness, reversal bump)
 Hysteresis

Total system delays

Computational delay (sample rate)
 Dynamic lag (combination of dead-time and rise-time)

Table 2

CATEGORISATION OF RESEARCH
Common format for summarising papers

1	<u>Simulation type</u> R&D or training Level of sophistication <i>eg</i> standard of cockpit (generic, specific) Computing technique (analogue, digital, array processor) and iteration rate
2	<u>Vehicle type</u> Fixed wing (combat, transport) Helicopter VTOL
3	<u>Vehicle characteristics</u> Dynamics SAS/control laws
4	<u>Task</u> Context: airline, general aviation, military training, ... Flight phase: taxi, take-off, climb, ... Specific flight task: hover, air-to-air, terrain following, ... Task objective: <i>eg</i> maintain wings level to $\pm 0.5^\circ$ in turbulence hover over a point to within ± 2 ft rms
5	<u>Environment</u> Winds, turbulence Visibility
6	<u>Pilot experience</u> Non-pilot, undergraduate pilot, squadron pilot, test pilot Transition training Psychological 'set' Instructional techniques
7	<u>Visual system</u> (this is only a basic set - see also AR-164) Image generation: TV, CGI, optical Image presentation: display technique, field of view, day/night, colour/mono Scene content and detail In-cockpit information: instruments, displays (head-up, head-down)
8	<u>Other cueing systems</u> G-seat, G-suit (non-platform motion) Auditory Buffet, vibration Control feel
9	<u>Experimental variables</u> In cues In vehicle or other characteristics
10	<u>Measures</u> Measures taken Analysis performed
11	<u>Comparison with flight</u>
12	<u>Principal conclusions</u> From Report Assessment

Table 3

LIST OF FLIGHT PHASES AND TASKS
 (See also AGARD AR-159, p 57)

<u>Context</u>	<u>Flight phase</u>	<u>Flight task</u>	
Airline	Taxi	Air-to-air combat	VTOL operation
General aviation	Take-off	Ground attack	Hover
Military training	Climb	Weapon delivery	Nap-of-the-earth flying
Studies of missions and tactics	Cruise	Aerial delivery	Oil rig support
Research and development	Descent	Navigation	
	Approach	Terrain following	
	Landing	Maritime search	
		Reconnaissance	
		Air-to-air refuelling	
		Aerobatics	
		Formation flying	

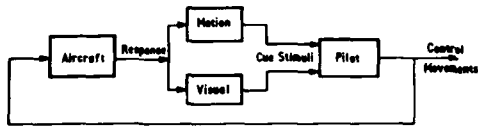

Fig 1 Simplified simulator control loop

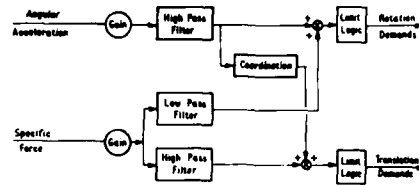

Fig 3 Simplified cue generation schematic

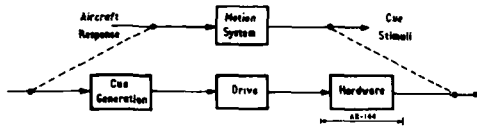

Fig 2 Complete motion system

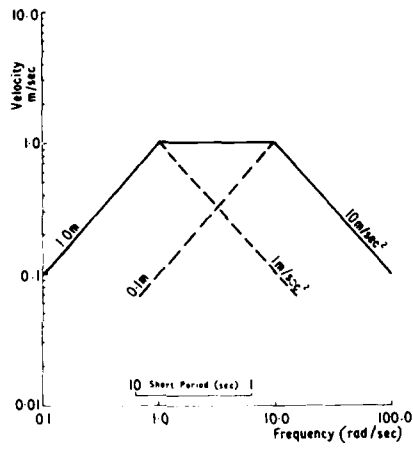

Fig 4 Motion performance diagram

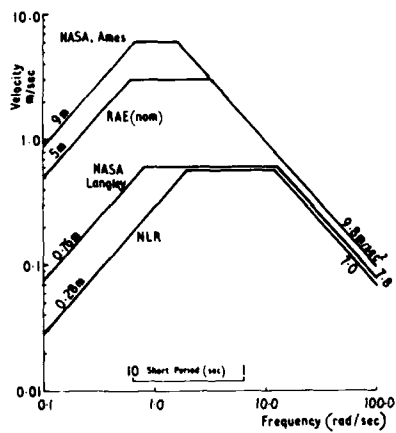

Fig 5a Motion performance diagram research simulators - heave axis

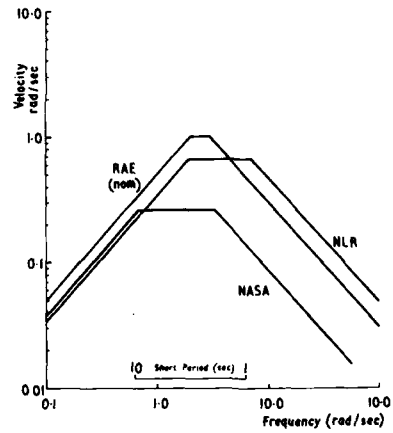

Fig 5b Motion performance diagram research simulators - roll axis

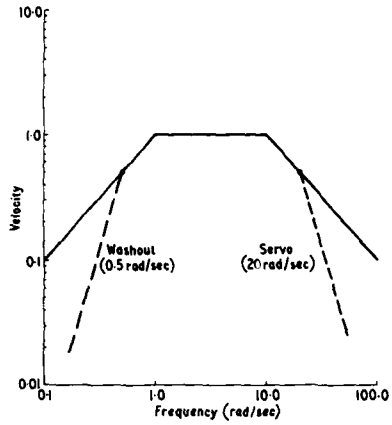

Fig 6 Motion performance diagram, with washout and servo response

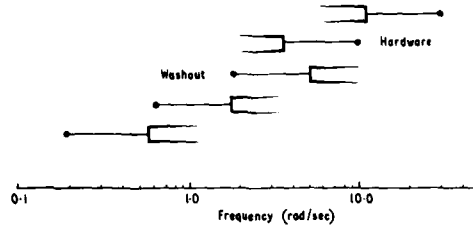

Fig 7 Regions of low phase shift

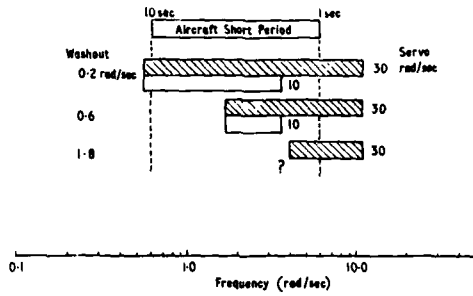

Fig 8 Examples of fidelity bands

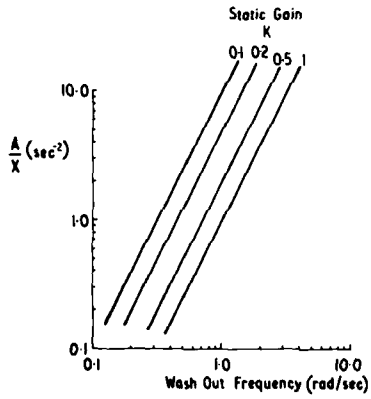

Fig 9 Acceleration/displacement versus washout and gain

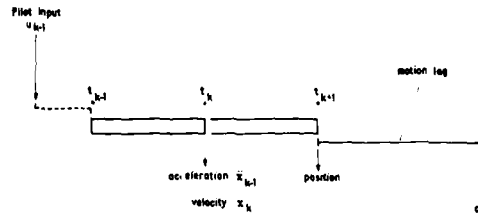

Fig 10 Contributions to motion cue delays

SIMULATION OF AIRCRAFT BEHAVIOUR ON AND CLOSE TO THE GROUND
- Summary of AGARDograph AG-285

by

A.G.Barnes
British Aerospace plc
Warton Division
Preston, Lancs PR4 1AX
United Kingdom

1. Background

The idea to produce an Agardograph on simulation aspects of the landing phase and ground roll came from Mr. John Buhrman, of NLR, in 1980. The FMP discussed how best to go about the task, and decided that rather than instigate a Working Group, they would invite an engineer from Europe, and another from the USA, to get the facts together, to report on the current state of the art, and to say what the future holds.

I was fortunate to be invited to join Mr. Tom Yager, of NASA Langley, to carry out the task. Tom is responsible for the Langley work on runway surfaces, tyre behaviour, friction measurement and all their implications on landing gear design. He runs the Landing Loads Track at Langley, which has produced a considerable amount of data in the past, and is still a unique and valuable facility. His association with simulator programmes using this data also helped enormously in putting the report together.

Our first decision was whether the scope should include the airborne phase prior to touchdown. I said that it should, Tom said that it should not. Having corresponded, I then changed my mind, because I could see that the magnitude of the task related to ground roll simulation alone was enough. But Tom also changed his mind, because he could see that the dynamic behaviour, immediately after touchdown was conditioned prior to touchdown, and that poor simulation in that area would make post touchdown simulation suffer. Finally, we agreed to cover both aspects.

Another decision we took was to include in the report an Appendix containing the equations of motion which determine aircraft behaviour on the ground. We used a comprehensive set, formulated by McDonnell-Douglas several years ago, for DC-9 and F-4D simulator studies. The purpose of including these equations, and the associated notation, is to indicate the components which interact to form a comprehensive simulation (figure 1). Most applications will allow simplification to these equations in some respects, but it is better to start with the full model, and make simplifications, than to build on a simple model. The latter method is likely to result in the omission of inter-actions, or axis transformations, or second-order terms, which may be vital in some circumstances. There is still room for improvement. At some time, we would like (a) to tidy up the notation (there are too many suffixes), (b) to recommend simpler sub-sets and (c) to define the applications for which they would be valid.

2. Contents

The first part of the report lists the benefits to be reaped from a good simulation of ground handling. They are considerable. They apply not only to Research and Development, but to Pilot Training. They apply to Military Aircraft of every type, and to Civil Aircraft of every type. In fact, we confined ourselves to fixed-wing aircraft; there is an equal case to be made for a report on the status of simulation of helicopters, on and close to the ground.

The benefits and applications are listed in the report, and are summarised on figure 2, under the headings of stability, control, performance, and training. Many of the areas listed are those where design uncertainty exists, or where real operation is hazardous. These cases have special appeal.

The report next considers the components which are needed to put together a simulation - the data set, the computer, the visual system, the motion system, and other cueing devices.

Modelling a vehicle on the ground is a complex task. The steering properties are influenced by many variables - aircraft geometry, wheel loading, tyre behaviour, dynamics of the suspension, and runway surface conditions. A well-structured model is important. Figure 3 illustrates how the 6 blocks of figure 1 are connected by the flow of information between them. The report indicates the data sources needed to implement these blocks.

On the subject of visual system requirements, it is suggested that current technology offers performance which is adequate for this type of simulation. On the ground, very realistic impressions of ground-roll, taxiing and parking are possible. However, in the landing flare manoeuvre, the performance measured in simulators compares badly with that measured in flight. It is suggested that some, if not most, of the blame is on the visual display shortcomings.

The report then strongly recommends the use of a motion system for landing and take-off simulation. The USAF is mildly admonished for their past attitude in decrying the value of motion cues (since the circumstances of their recommendations are often overlooked). In contrast the FAA, in defining Training Simulator Approval Procedures, insist on 6 axis motion systems for Phase II and Phase III simulators. Some studies have quantified the benefits of motion cueing. Also, the subjective impressions that are conferred on the pilot by motion - jolt on touchdown, lateral forces in taxiing, deceleration when braking - add greatly to the realism.

Examples are quoted of various programmes, to demonstrate the effectiveness of simulators. Both Research and Training applications are presented. They illustrate that many operators have for many years made good use of simulators in this phase of flight, for a wide variety of problems. Even so, simulator improvements now offer much greater possibilities.

3. Recommendations

The report concludes that flight simulation techniques now give the potential to represent an aircraft's behaviour on and close to the ground with a high degree of realism. Consequently, the scope of both research simulators and training simulators is extending. The success depends critically on the accuracy of the model. The model itself depends on careful measurement of runway surface conditions, the effects of rain, ice and snow, the behaviour of tyres on these surfaces, and full scale validation of undercarriage models.

As well as making better input data available, there is also a need to review the mathematical models of the aircraft on the ground, both with respect of notation, and with respect to relating model complexity to application.

Experiments could usefully be conducted to identify the hardware performance of visual and motion systems which are critical for successful ground roll simulation.

Finally, more understanding is needed of the difficulties in simulating the landing flare. Currently, the best simulators give a subjective impression that all is well, and that it is possible to perform landings as well in the simulator as they are performed in flight. The report points out that when performance on simulators and in flight are compared, the results are less convincing.

**BRITISH
AEROSPACE****Ground Model Components**

Figure 1

**BRITISH
AEROSPACE****Applications for Ground Simulation****Research**

STABILITY	CONTROL	PERFORMANCE
TAXYING, STEERING	TAKE-OFF - PITCH ROTATION	ACCELERATE - STOP
DIRECTIONAL STABILITY	LANDING FLARE	TAKE-OFF DISTANCE
- TAKE-OFF	DIRECTIONAL CONTROL	LANDING DISTANCE
- TOUCH-DOWN	- GROUND ROLL	ATMOSPHERIC EFFECTS
- LANDING	- TAXYING	TYRES AND RUNWAY SURFACE
- EFFECT OF CROSS-WIND	HANDLING CRITERIA	LATERAL DISPERSION AT TOUCH-DOWN
- EFFECT OF REVERSE THRUST	- C.G. VARIATION	OPERATIONAL LIMITS

Training

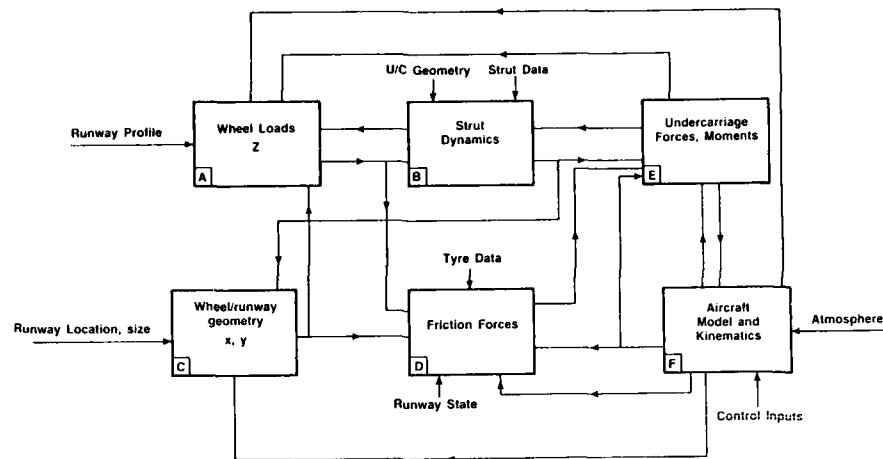
TAKE-OFF	LANDING
PUSH-BACK, TAXI, HOLD	FLARE TECHNIQUE
STANDARD PROCEDURES, V_1 , V_2	USE OF DE-CELERATION DEVICES
FIELD LENGTH	ENGINE OUT CASES
ABORTED TAKE-OFF	OTHER FAILURES
NOISE ABATEMENT	WIND AND WEATHER EFFECTS
EMERGENCIES	TAXI, PARK, SHUT-DOWN

Figure 2

**BRITISH
AEROSPACE**

Ground Model Inter-Actions

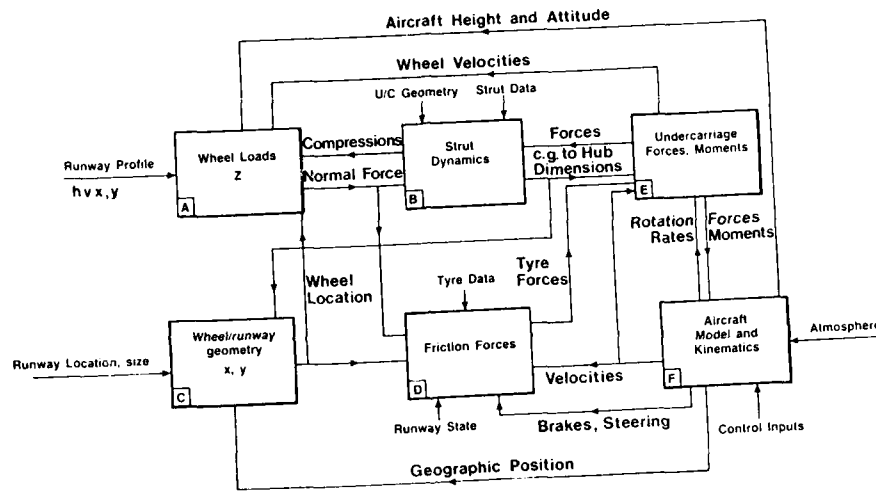

Figure 3

USE OF VDU'S BY FLIGHT SIMULATOR INSTRUCTORS

Mark A Brunt
Human Factors Consultant
Research & Development Dept
Rediffusion Simulation Limited
Gatwick Road
Crawley
RH10 2RL
United Kingdom

SUMMARY

This paper compares the development of VDU-based simulator instructor stations with some Ergonomics rules, and provides a discussion around design aims and practical experience. Further rules are developed to establish a baseline for designers, procurers and users of instructor stations.

1.0 INTRODUCTION AND BACKGROUND

I will start by thanking AGARD for inviting me to present this paper, which I have tried to make interesting and useful to those of you concerned with procuring, designing and using simulator instructor stations.

1.1 PERSONAL INTRODUCTION

I have worked as a Human Factors specialist in the Research and Development department of Rediffusion Simulation since 1976. My greatest area of interest in training simulation has become the instructor's interface with the simulator, and I believe it is in this area that the most productive developments will be made in the not-too-distant future. The only area of simulator training which has greater interest is a study of the instructor/student interface, but this paper will be limited to a few aspects of the instructor/simulator interface as seen from an Ergonomics viewpoint.

1.2 An Observation

Each time a complex system is redesigned, the performance is upgraded in some way, usually to include new capabilities, but the old capabilities are seldom withdrawn, so with each "iteration" the system becomes more complex. I believe that this is repeated until the complexity finally overtakes the usefulness, and the designers have to stop and reappraise the system aims, throwing out or automating those tasks which overload the human being concerned. What is really interesting is the speed at which these cycles happen in the area of simulator instructor stations.

1.3 Subject Matter for This Paper

Since the early 1970's, flight simulator instructor stations have shown several trends for change. Of these, the three most interesting changes are the positioning on-board where possible, the availability of pre-programmed lessons, and the almost universal introduction of VDU-based systems for instructors. In this paper I shall talk about the implications of these changes for instructors, the lessons which have been learned so far, and throw questions at you all to help in finding answers to problems which remain.

1.4 Historical Background

Just as the simulated exercise is "real time", so originally was the function of all the instructor's controls. An instructor had a direct switch or knob for each action, and operated it when he wanted that action. This was direct in operation and direct in time. Clearly, this is the simplest way of doing anything.

As the number of functions to be controlled increased with time (nobody wants to reduce them!) we reached the point where there were too many controls for the instructor to reach easily, so various multifunction systems were designed. These effectively added a third dimension to the instructor's panels, giving indirect operation - the instructor had to select a page or frame before he could select the "action" required. The controls were still real time, but indirect.

The next design iteration recognised the indirectness and showed various attempts to pre-programme the simulator exercise. This was more or less successful, depending on the predictability of the exercise. This is the current situation, where an individual design of station exhibits direct and indirect, real time and pre-programmed attributes.

I am suggesting that this combination will persist in the immediate future and any particular design will succeed or fail entirely on the ergonomic qualities of its console design. So here are some rules for the design of man/machine interfaces in general, and I'll follow up with some specifics applicable to flight simulation.

2.0 ERGONOMICS RULES FOR CONSOLE DESIGN

The console must provide monitoring of the exercise, access to the controls of the simulated aircraft in its environment, and in many cases, assistance to the instructor in his assessment of the crew performance. This involves a very large amount of information to be outputted to and inputted from the instructor, and is increasing with time. The present number of control and display items is only possible in practise by using comprehensive, flexible displays with an appropriate keyboard such as the now almost universal VDU terminal, but I'll return to that in a moment. Here are those rules.

2.1 Basics

Rule 1 - The equipment must provide the operator with all the necessary inputs and outputs to perform the task. Non task-orientated items should be minimised.

Rule 2 - The operator must be positioned comfortably with access to all parts of the station. Where possible everything should be within reach, sight or hearing as appropriate.

Rule 3 - The equipment must be appropriate to the environmental levels of lighting, noise, movement, where these are imposed by other factors.

Rule 4 - The equipment and the task of operating it must be appropriate to the nature of the operator (not the equipment designer, commissioning engineer or the procurement officer!).

2.2 Controls

Rule 5 - The instructor must know what controls are available at any instant, and the appropriate controls must be available when wanted.

Rule 6 - The controls must be labelled, grouped or classified to minimise searching, having regard to their importance.

Rule 7 - There must be feedback of all instructor inputs at all levels. The levels are:

- a) that the control has been operated
- b) that the "machine" has "seen" an input
- c) that the "machine" recognised what is wanted
- d) that the "machine" has done or is unable to do what was wanted.

Rule 8 - Except for analogue controls, which should be matched to analogue displays where possible, there is no need to use the same man/machine channel (i.e. sight/sound/tactile) for feedback at any particular level.

2.3 Displays

Rule 9 - Rules 5, 6 & 7, above also apply to displays.

Rule 10- Displays should be linked as closely as possible to their associated control.

2.4 Other Items

Rule 11- Other items of an associated nature (e.g. writing area), or a personal nature (e.g. coat and bag stowage) must not be neglected.

Rule 12- The operator must work in complete safety, and without any long-term injurious effects.

2.5 Expansion of Rule 4 - THE OPERATOR

Flight simulator instructors are a perfect example of the importance of Rule 4 above. Such people are normal human beings, but they have skills and expectations which make them special. A typical instructor, if there is such a being, will be male, probably over 40 years of age, (which may mean limited eyesight and/or hearing) and almost certainly a trained pilot, usually current on the aircraft being simulated. He will therefore have a comprehensive understanding of the "aircraft" part of the simulator, and a much more limited knowledge of the computer, electronics and instructor station. He is unlikely to be familiar with QWERTY keyboards or computer jargon.

2.6 Conclusions from Rules

Let us now look at VDU-based instructor stations and see how their design compares with these rules. In particular we will look at the VDUs themselves, including the known and supposed dangers from their operation in general industry. You will note that I have generalised these rules, but for example, I will take a VDU character which is too small (for an operator to read,) as being a failure under rules 1, 2 and possibly 4, 5, 6 and 12.

AD-A173 875

FLIGHT SIMULATION(U) ADVISORY GROUP FOR AEROSPACE
RESEARCH AND DEVELOPMENT NEUILLY-SUR-SEINE (FRANCE)
A M COOK ET AL. SEP 86 AGARD-CP-408

2/4

UNCLASSIFIED

F/G 5/9

NL



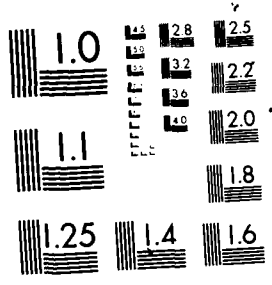

MICROCOPY RESOLUTION TEST CHART
NATIONAL BUREAU OF STANDARDS 1963-A

You will also note that I am not going to specify dimensions, angles and viewing distances, because in my experience you cannot write down the design parameters. Designs have to be verified by full-size trials or mock-up assemblies. If anyone tries to describe how pleasant a motor car is to drive, they don't specify the driver's cockpit, they just say "Take a test drive!"

3.0 VDU'S IN SIMULATORS

3.1 Physical and Hardware Aspects

Most modern instructor stations use 20 inch (51 cm) raster-scan monitors; the older calligraphic CRT's are being phased out. A minimum of 7 colours has become standard, and these are used fully saturated against a black background. Typically 24 to 40 lines are displayed, with up to 80 characters per line. At a typical viewing distance of about 2 feet (60 cm), this gives character sizes of a larger viewing angle than typed letters on paper. At Rediffusion, we contend that our VDU characters are readable by most instructors at a cross-cockpit distance of up to 6 feet (180 cm).

For on-board instructor stations the VDU's will be used "sideways" and probably mounted very close to the instructor's face. Brightness will be limited to a fairly low value to accommodate simulator visual systems, and the associated controls and switches will need to be illuminated. The instructor is sitting in the dark, facing sideways to the VDU, moving around, and the VDU system is not allowed to make noises to him.

Question 1 - What feedback of control inputs can be used in this situation?

Before answering this one let us consider the off-board situation, where there are a mixture of digitally displayed simulation parameters and analogue aircraft instruments, control VDU's and communications networks. Some of the VDU's may even be accessible only through QWERTY keyboards, and have a hierarchy involving three or four page changes to change from, say, wind speed input to the insertion of an aircraft malfunction.

Question 2 - Can the Instructor "switch" mentally from the VDU keyboard to the training situation?

Answer to questions 1 & 2 - There are problems with existing designs.

The problem of feedback to an on-board instructor is lessened by the self-evident nature of most, but not all the items being controlled: for example, a fire malfunction causes a bell to ring, but a latent fault such as an engine start problem will not be evident until the engines are started. Remember Rule 7. If the instructor isn't looking at the VDU, you cannot expect him to see something changing on the screen. I know this is a silly sounding example, but the problem is anything but silly. I am using it as an example of the importance of VDU positioning. So here we have our first rule.

VDU Rule 1 - Position the VDU where it can be seen.

By "seen" I am including character size, colour, brightness and disability glare. Clutter is also critical. Assume that the screen is not readable if each page is set out like a telephone directory! Remember that what may be suitable for a youthful computer programmer in a well lit office, may well be inadequate for a mature instructor who probably wears bifocal spectacles, sitting with his neck twisted around, working on something else (the training) in the dark, on a motion system. You are reminded of Rule 4.

I am also including in VDU Rule 1, the problems of neck pain, eyestrain etc. commonly associated with VDU usage and currently enjoying almost daily coverage in the national press.

3.2 Menus and Page Hierarchy

Assuming that the physical details (already discussed) are reasonably sorted out, the most difficult area left to the designer is what should be on the screen, how it should be categorised for access, and how it should be displayed. In the "old days", there was a limitation as to what could be put on a hardware panel, and everyone understood what could and could not be done. This meant that design discussions and procurement specifications were reasonably simple to arrange. Now there is seemingly no limit to what can be displayed, and every aspect of the simulator (even the room lights) can be controlled by a VDU and keyboard if that is considered a good idea. Assuming that there will not be much information on permanent display, the available controls and displays will be arranged on separate pages.

Question 3 - Do you classify the pages in groups according to function, or sequence of use, or importance?

This is really the thousand dollar question - The answer is simple but unhelpful.

Answer to Question 3 - For some simulators and some stages of training, and some levels of instructor experience, any one or more of these three classification methods may be optimum.

For a simulator manufacturer it is tempting to hand the customer a sheaf of page coding sheets and ask him to design his own pages. This is avoiding the problem. Designing VDU pages is a quite separate skill from training pilots to fly aeroplanes, and it is a rare instructor who could make a good job of page design. In particular, the instructor probably has experience of older VDU systems with many more limitations than the current one, and page design is closely associated with the ease of page changing and line access. The result: almost certain failure under the rules described so far.

One solution to this problem is seen as the "let's have it all" syndrome, in which the procurement officer tries to make everyone happy by insisting on duplicate manual controls for many of the simulator functions. This is sometimes hidden in the claim that the simulator must be useable in the event of VDU breakdown. This approach is probably the least successful for several reasons.

Reasons

- 1) Console size and Reach - If the console is extended to include many extra controls then it will certainly become larger and the instructor will be unable to reach all the controls. Remember that what you cannot reach, you will not use. Once again, this may sound silly, but I know of several large instructor consoles which are for two instructors, but are the size for four men. I will expand on this subject at question time if the subject is raised.
- 2) Limitation of Training - Some instructors will never learn the full capabilities of the VDU system if half of the controls are available manually. What often happens is that the non-manual half is never used.
- 3) Cost - Extra manual controls cost extra money; both directly and also because they force the manufacturer to make a different console for each new simulator. This "bespoke" console building also limits the ergonomics effort which the manufacturer can put into each design. It also increases maintenance costs.
- 4) Detail - The greatest problem with this approach is that it diverts attention of both the manufacturer and the eventual user from the absolutely vital task of the page design.

As I have said, the classification of the pages and their contents is probably the most critical part of the console design task. But first, remember that there are two distinctly different ways of selecting and using pages. Let us look for a moment at these two ways and compare them.

The first, and older method of selecting and using the pages is to have a numeric keypad, and select pages by their number. A variant of this is to have a mnemonic name for each page coupled with an alpha keyboard. This has two advantages. First, the instructor has direct access to any page in the system from any other; in fact it is quite easy to remember the most-used page numbers, and people are nowadays familiar with a zero-to-nine keypad. Secondly, the control switches are compact, and may form the basis of a simple remote controller for on-board use. However, the disadvantages are also very real. There arises with this system, the concept of different modes of operation for the keypad.

Page mode - for changing pages
 Line mode - for selecting the line
 Preview mode - for just looking.

This is confusing, to say the least, and usually involves complicated feedback in the form of mode indication and cursors which are nothing to do with the task of training pilots.

The other way of selecting pages is to abandon page numbers and do everything with "line select". This is much simpler for the instructor, but means that the pages which are low on the page hierarchy may be very indirect to access. Unfortunately the resultant balance between page size and ease of changing pages depends on the system speed and switch operation, which may not be known at the time the pages are being designed.

Here, at last I can offer some help.

An hierarchy of greater than two levels is not useable in practice for a real-time task like controlling a flight simulator.

The solution is to have the master index and probably the malfunction index available as direct page select switches. I recommend that direct page select switches be grouped into three categories:-

- 1) Master index and Maintenance index
- 2) Malfunction Page select (up to 20)
- 3) Other direct page select and Graphics.

3.3 The Select/Activate Dilemma

If directness of operation is important for VDU systems then the idea of a directly-acting line select would seem to be correct. Returning to my introduction, directness is an advantage. However there is a counter argument. Pressing switches at the VDU screen sometimes causes a real action, such as setting a malfunction, and sometimes simply changes the page on display or moves a cursor. This difference may be unnerving to the instructor, who could be afraid to manipulate the pages for fear of doing something harmful to the training.

A solution to this problem is less direct, but may be more satisfactory. It is to have a separate "ACTIVATE" switch function for the VDU system, which will activate the selected function or line. Such a system has other advantages also. It automatically allows previewing of pages and individual lines, and the "activate" switch may be remote, with its own feedback if required. This can be very useful if a touch screen is used: more about that later.

3.4 Graphics

We must all accept that instructors, like most people, tend to think in pictures. Therefore, obviously, any graphics available with the VDU system will probably be useful. However, the task of designing graphical pages for instructors is extremely closely tied to a deep understanding of the way a particular simulator is used. It is no use taking a computer graphics system and assuming that the graphics will be suitable. What is really needed is pictures rather than graphics. Let me leave this subject here for a moment.

3.5 Colour

Some tips on the use of colour. Colour is the third dimension of the VDU screen. Use bold colours for headings and colour changes for selected lines etc. System colours should be standardised to suit conventions such as red for "stop" and "green" for go. Here is the first problem which arises with CRT colours. Since they are additive on the screen, it is important to remember the grey-scale value for the saturated colours. For example, pure red is quite a dim colour since it has no blue or green components. Also, people with defective colour vision tend to see red colours dimly - not the best colour for a heading or title line on a page! Remember that over ten per cent of the male population has a colour vision deficiency.

A second problem with colour is that it demands greater resolution from the CRT itself than an equivalent monochrome system. Note that this is not the same as television, where you are looking at a picture as a whole. I think that it is nowadays accepted that colour VDU systems will be unacceptable if they are based on conventional television line rates and low resolution shadow masks.

3.6 Touch Operation

One of the greatest (and least recognised) problems with VDU systems is the method of associating lines with control switches. Remember Rule 10. This is vital. The mental workload in reading a line number and finding the same numbered switch (or using a zero-to-nine keyboard) is considerable.

The only way to overcome this problem in a simulator environment is to use a touch screen overlay, so that the instructor's finger selects directly the line or action required. In this case the on-board problems (-sideways operation, motion, darkness, no audible feedback) would seem to rule out touch operation: however, if "select" and "activate" are separated, the system works very well indeed, particularly if the pages are well designed. Obviously the line spacing needs to be wide, but this helps the instructor anyway.

There are many ergonomics details which are essential to the success of a touch screen operation. For example, the wrong touch resolution or screen type can be disastrous. Page design becomes critical, and the method of changing variables needs care in design.

3.7 Summary of Comments on Pages and their Contents

These paragraphs may be summarised into the second, and final rule. I'll call it Rule 2.

VDU Rule 2 - Page design is critical

Page design is too important to leave to the user or the manufacturer. A good system must be developed by the manufacturer, and his customer must take part fully in designing pages. The system must also allow new pages at any time.

4.0 CONCLUSIONS

VDU's are here to stay for simulator instructor stations. They are the only way of giving the instructor all the monitoring and control he needs. We are now on our third generation of such designs, and I believe we understand most of the problems. Hopefully with this experience we can start to make the instructor's life easier rather than harder over the coming years.

I will close by showing some slides of VDU's i. simulators to illustrate what I have said, and to provoke discussion.

PROGRESS IN THE IMPLEMENTATION OF AGARD-AR-144 IN MOTION
SYSTEM ASSESSMENT AND MONITORING

by

K J Staples
Royal Aircraft Establishment, Bedford MK41 6AE

W Love
Cranfield Institute of Technology, Cranfield, Bedford MK43 0AL

D Parkinson
Singer Link Miles, Lancing, West Sussex BN15 8UE

SUMMARY

After a brief explanation of the techniques defined in AGARD-AR-144 a description is given of two systems which have been built and tested to satisfy the requirements of the AGARD Report. Each system is stand-alone and only requires the user to supply the sensors on the motion system itself. One system, from Singer Link Miles, is especially suited to six degree-of-freedom, synergistic motion systems, whereas the other, from Cranfield Institute of Technology, is more appropriate to systems with independent axes. The systems have each been used on several different motion systems and some examples of measured results are given.

1 INTRODUCTION

RAE provided a member of the AGARD Working Group which devised, codified and defined the procedures for motion system assessment outlined in AR-144. During the course of their deliberations all members of the Working Group made measurements on their motion systems. These were essentially research exercises, using specially generated software, run on the host computers of the various simulators. As a result of these experiments the validity of the techniques of AGARD-AR-144 was effectively demonstrated. However, these techniques are superficially quite complicated and indeed it has been suggested that a simplified version should be produced to allow the more general application of the procedures. Such might well be needed if each simulator operator went his own way to produce a test schedule. Singer Link Miles Ltd and RAE, however, adopted the philosophy that either a stand-alone, or readily incorporated, system of hardware and software should allow the full implementation of the Working Group recommendations.

Accordingly, RAE sponsored two implementations of AGARD-AR-144 for universal, or at least widespread, application. The first of these was started at Singer Link Miles in August 1981 and was effectively demonstrated as a fully operational system in May 1983. Its application was specifically to the six degree-of-freedom, synergistic motion system and it is for these systems that it is fully developed though adaptation to alternative systems is clearly possible.

The second system was started at Cranfield Institute of Technology in November 1982 and was demonstrated in July 1984, although further enhancements have been incorporated up till the Spring of 1985. It is of universal applicability but its very versatility means that rather more user participation is needed compared with the first system. It essentially provides to each axis the sine waves (and step inputs) required by AR-144 and collects and analyses the acceleration and position outputs; it is ideally suited to independent-axis systems. It does not perform the transformations necessary to drive (and receive back positional information from) synergistic systems; at present the host simulator would have to do this.

After briefly explaining the principles of AGARD-AR-144 this Paper describes in general terms the two systems which have been developed (hereafter called the SLM system and the CIT system), gives examples of some of the measurements that have been made and draws therefrom some lessons which have been learnt about the technique and difficulties of implementation.

2 BACKGROUND TO AND PRINCIPLES OF AGARD-AR-144

The Flight Mechanics Panel established Working Group 07 in October 1976 on the dynamic characteristics of flight simulator motion systems. The final report was approved in October 1978 and AR-144 was published in September 1979.

It was established early that consideration would be given only to techniques of measurement which would reveal the quality of motion systems and that no judgement would be made as to acceptable or satisfactory characteristics. Nevertheless, it was important that the metric be appropriate to the sensation from which a quality acceptability would be decided; therefore, most measurements are made in terms of acceleration.

The dynamics of the motion system are considered under five headings:

- (a) Excursion limits, for single degree of freedom operation.
- (b) Describing function.
- (c) Linearity and acceleration noise.
- (d) Hysteresis.
- (e) Dynamic threshold.

The first four are measured using sinusoidal inputs of varying frequency and amplitude. The command inputs and measured outputs are in terms of acceleration for (a-c) and in terms of position for (d). For (e) a step input of acceleration is required. In general measurements are made at intervals of 10 ms with a run length of 1024 data points taking 10.24 seconds at each frequency and amplitude.

Analysis of (a-c) above is by discrete fourier transform from which it is elected to extract:

- Fundamental (first harmonic).
- Second and third harmonics.
- Fourth and higher harmonics.
- Stochastic residue.

Fig 1 shows how this information can provide the describing function, linearity and acceleration noisiness of the motion system. The operational system limits are determined by assigning a maximum permissible acceleration noise ratio (obtained as in Fig 1). Ratios are obtained by dividing by the standard deviation of the output fundamental.

Only one axis is driven at a time, about its mid position, but all other axes are required to be active, under servo control and held at their mid position. The so-called 'parasitic' acceleration, peak and standard deviation, of these undriven axes is also measured.

Hysteresis is self-explanatory except that, because it is normally very small, output error is plotted against input, unlike the normal hysteresis loop.

Dynamic threshold is the time for output acceleration to reach 63% of a step input acceleration.

If each separate input and subsequent measurement is considered to be a run, then to make all the measurement defined in AR-144 for any one driven axis requires between 50 and 80 runs.

3 SYSTEMS

In this section we described the two UK systems that are available for motion test embodying the principles of AGARD-AR-144.

3.1 The SLM system

3.1.1 Introduction

The origin of the motion test system described in this section was the desire to provide an easy, meaningful assessment of the performance of a motion system for both initial acceptance and continuing maintenance. 'Easy' meaning no need for specialised knowledge of measurement procedures and equipment, 'meaningful' implying the presentation of results in a manner which required little further processing or interpretation. Also, in order to apply this test procedure to as many simulator configurations as possible, it was decided to produce a stand-alone system independent of the host computer. Development of such a system and its subsequent use would not be inhibited by the facilities or general performance criteria of a particular simulator system.

The stand-alone system contains its own microprocessor computing system including necessary programs stored in Read Only Memory. The motion system under investigation can be driven totally independently of the host simulator via the motion servo electronics. It provides a low cost approach encouraging general acceptance of the system and can be used during simulator development or during routine maintenance, times when the host computer is likely to be busy with other matters.

The prototype unit has been developed and successfully demonstrated on three different six DOF motion systems. Whilst the system has yet to include all the test routines specified in AGARD-AR-144, it does prove the feasibility of doing so and also provides useful test functions as described later.

3.1.2 System configuration

The system comprises the following major items:

- (1) Electronics cabinet (19" x 15" x 15").
- (2) Visual Display Unit.
- (3) XY plotter.
- (4) Six accelerometers plus interface buffer.

Fig 2 shows a block schematic of the system, a basic design consisting of microcomputer, combined RAM/ROM circuit card and I/O card. The accelerometer interface is contained in a separate box located on the motion baseframe; during testing, accelerometer measurements are transmitted serially via differential data lines to minimise cabling and noise pick-up. The salient feature of each circuit card are as follows:

- (1) Microprocessor circuit card
 - Intel 8086 plus 8087 microprocessors.
 - 20 Kbytes board RAM/ROM memory.
 - RS 232 port.
 - Local bus interface.
 - Multimaster system bus interface.
- (2) RAM/ROM circuit card
 - 64 Kbytes of RAM used for variable data.
 - 24 Kbytes of EPROM for program.
- (3) Linkage circuit card
 - Six digital to analogue converters.
 - Data acquisition unit to measure position feedback.
 - Serial interface and statisticiser for accelerometer buffer.
 - RS 232 port to drive XY plotter.
- (4) Accelerometer buffer unit
 - Six buffer amplifiers.
 - Data acquisition unit.
 - 1 MHz serialiser and transmitter.

The software is written in PASCAL, a high order language very suitable for this type of application. It allows use of the 8087 numeric processor for floating point operation (to 80 bit accuracy) and also gives the programs close control of the hardware I/O for time critical routines.

The software, once developed and tested using standard microprocessor development equipment, is then held in EPROM to minimise cost of the final unit, and provide ease of use.

As previously mentioned, the motion test system is a stand alone system with the software providing its own drive geometry equations. This also eases the interface to other software modules responsible for overall control, data sampling and analysis. The drive software and data sample are executed at 100 Hz and each particular test lasts 10.24 seconds. During each iteration, readings for all six accelerometers and six leg positions are recorded in RAM for subsequent analysis.

After one test run the accelerometer readings are first corrected for gravity and then processed using a fast fourier transform. From the frequency components various parameters such as gain ratio, low frequency non-linearity, acceleration noise and parasitic acceleration noise are calculated as described in AGARD-AR-144.

Two other main software modules provide the user with a menu of test functions and a number of graph plotting routines. The latter makes use of a Tetrax 4662 plotter providing a means of presenting both basic plots and alpha/numeric information.

3.1.3 Test options

The prototype motion test system provides the following tests:

- (1) Standard constant frequency.
- (2) Standard constant amplitude.
- (3) User-defined constant frequency.
- (4) User-defined constant amplitude.
- (5) Single test only.
- (6) Manual position control.

For tests (1) and (2) a standard set of test points has been selected within the system limits of the motion system. The standard constant frequency tests give the user a choice of ten frequencies, each frequency having an associated range of acceleration amplitudes. Similarly, there is a choice of ten standard amplitudes. Throughout these tests each amplitude is shown as a percentage value of the system acceleration limit in the respective axis. Tests (3) and (4) follow a similar theme but the user has a greater choice in terms of frequency and amplitude with the intention of providing an increased level of diagnostics.

The "single test only" allows the user to select a single test point anywhere within the system envelope. After driving the motion system in this manner and subsequent analysis, a frequency spectrum and a noise trace is made available via the plotter.

3.1.4 Implementation

The installation of this autonomous test facility provides minimum impact on the overall simulator. The output voltages for the six hydraulic legs of a six DOF motion system are available for injection into maintenance points available on most motion electronic cabinets. The only other necessary task is to install six accelerometers, mounted as three pairs at predetermined points on the motion baseframe.

Each single test drives the motion system for approximately 22 seconds. This includes a run-in time of 5 seconds, a data sampling time of 10.24 seconds and a run-down time of about 7 seconds.

3.2 The CIT system

3.2.1 Introduction

The implementation of AR-144 by CIT was required to be:

General purpose, capable of being configured to drive and analyse data from different simulators.

Transportable.

Have moderate graphics capability.

Have high level language programming support.

Good I/O, and peripheral support.

Extendable (for future expansion if required).

A data acquisition system under full user control.

The emphasis is therefore very much on versatility with the ability readily to test any simulator, anywhere.

3.2.2 System configuration

The system developed is comprised of two principal hardware components:

(1) A Hewlett Packard 9826 desk top computer which performs three principal functions:

Overall control of the system.

File handling.

Analysis.

(2) An Intel 8086 based data acquisition system.

Fig 3 shows a picture of the complete hardware and Fig 4 shows a schematic of the analysis equipment.

The basic operation of the system is for the HP9826 to generate and scale the excitation waveform, and downline load this waveform to the Intel acquisition system. On command from the HP9826 the excitation signal is output via a DAC from the acquisition system to the platform motion system and the response of each axis read by an ADC (Data Translation DT711). The acquired responses are then transferred back to the HP9826 for storing and subsequent analysis.

Data acquisition and analysis are treated as separate tasks. This has the advantage that the platform motion system is occupied for the minimum time, and the raw data may be analysed (and if necessary re-analysed) off line. All relevant data from all input channels is saved on floppy discs, including the driving signal. All software in the HP9826 is written in Pascal.

3.2.3 Data acquisition system

The data acquisition system is controlled by a permanently resident EPROM program. This program, written in CORAL 66, communicates with the HP9826 via an 8-bit parallel bus to allow reasonable data rates between the two machines. Simple, one-character commands sent from the HP9826 controller are obeyed by the acquisition system.

Up to 8 DAC output channels are available, though only one is normally active at any time, and 16 ADC differential input channels may be acquired. (In practice because data RAM is limited to 32 Kbyte only 14 channels may be acquired; this has never to date been a problem and additional memory can be added.)

3.2.4 Modifications to AR-144

The original specification of a 10 ms data rate produces a fairly coarse output signal at frequencies above say 3 Hz. In the CIT implementation the output signal is smoothed by linear interpolation of the excitation signal, which is then output every 1.25 ms. (Data is still only sampled at 10 ms.)

The acquisition system based on an 8086 running at 8 MHz has more than adequate processing capability to handle this additional processing.

Another area of practical importance, not covered in the original AR-144 Specification, is the starting and stopping of the motion platform. The method developed is to pre-cycle the platform with a linearly increasing excitation signal, and after acquiring data bring the platform to rest with a linearly decreasing signal. This processing is also done by the 8086.

This start-up sequence has the additional advantage that a velocity driven system will oscillate about its mean position. Going straight into the full sine wave would require an offset starting point; or, alternatively, the use of a cosine wave, which puts full velocity drive into the system at start-up.

For the majority of measurements to be taken the motion platform should have attained a steady state condition. If possible this is achieved by beginning with the linearly increasing transient, cycling the platform for one ten second period, then taking the required measurements during the next ten second period. The stopping transient may be applied as quickly as is practical, measurements are not taken during these transients. Typically it will take 30 seconds for each applied amplitude and frequency. (Thus for a single axis 10 frequencies, 5 amplitudes the platform will be required for approximately half an hour.)

3.2.5 Using the test equipment

The output from the DAC and input to the ADC is ± 10 V. Only a single output channel is normally active at any given time, but up to 13 inputs may be recorded.

The principal steps to be performed prior to a full scale run are:

- (1) Prepare a system file - this file allocates channels, specifies titles and scaling factors.
- (2) Prepare a run file - this file contains the amplitudes and frequencies of the excitation signals to be used to drive the platform.
- (3) Run the acquisition program.

In practice this is preceded by an on-line test session. A facility exists to allow the user to 'manually' drive the platform. The platform is driven gently and the response on each axis checked. The ADC's may be programmed to give voltage gains of 1, 2, 4, and 8. On parasitic channels with low signal levels a high gain is required for maximum accuracy.

3.2.6 Implementation of AR-144

The implementation of AR-144 is fairly complex. The large number of possible sensor locations/type make a general purpose analysis program impractical. For a particular simulator a certain amount of program customisation is unavoidable. When linear accelerometers are mounted in a rotating frame gravity terms must be computed and removed if true parasitic motions are to be evaluated. If linear accelerometers are not located at the centre of gravity then other terms must also be accounted for. Clearly when a particular motion platform is being exercised enough information must be simultaneously acquired to permit subsequent analysis. In general the angular position as well as the acceleration responses are required.

The program explicitly allows the user to specify these variables, ie the removal of gravity terms, the use of pairs of linear accelerometers for rotary acceleration, or rotary accelerometers, the 'x, y, z' correction to accelerometer position, and even to correct for centripetal acceleration, if significant.

An additional complication was the requirement that the system be capable of driving position, velocity, or acceleration demand systems. The only modification required is to specify in the system file which demand is expected.

4 MEASUREMENTS

A characteristic of AGARD-AR-144 is that a complete examination of the performance of a motion system produces a very large number of results. The complete array for a specific motion system is of no especial interest here but an indication of the scope and a few examples of the graphical presentation are given.

4.1 The SLM system

All tests are undertaken with a sinusoidal input; there is no step response implemented yet and neither has there been any attempt to provide all necessary tests within AGARD-AR-144 in a completely automatic function.

After the completion of a test it takes approximately 2 min to calculate and plot one of various graphs available. The frequency spectrum graph plots the response from 0 to 35 Hz together with various other data as shown in Fig 5. The data shown can be made available as a frequency plot after any sequence of tests option has been completed. Obviously the output plot is associated with the axis originally selected, however, output plots of parasitic acceleration noise can be selected for any other axis with appropriate criteria automatically recorded on the graph, as shown in Fig 6.

4.2 The CIT system

With this system all the tests required by AR-144 have been implemented. As with the SLM system, the analysis and plotting of one of the graphs would take about 2-3 min though the technique would normally be to acquire all the results, conduct all the analysis (probably for each driven axis separately) and plot all the results. On the basis of 50-80 runs per axis (see Para 2) this would take about 1 to 1½ half hours per axis.

An example of a describing function plot is given in Fig 7. The annotations on the figure can be expanded to indicate, for example, which system is being tested and when. Figs 8 and 9 show respectively noise ratio for the driven axis and parasitic noise on an undriven axis, the latter indicating both peak and standard derivation. All units are SI - m, rad, sec.

The system also prints out the results of all runs in tabular form and indicates the contents of the run.

5 CONCLUDING REMARKS

The use of a stand-alone SLM system provides an easy to install test system for six DOF motions system. Embedded software provides the drive functions and analysis following the guidelines of AGARD-AR-144. The menu selection of standard functions and the automatic plot of graphical plus tabular data makes the system easy to use and illustrates how the recommendations of AGARD-AR-144 can be made freely available. However the dynamic threshold test has not been implemented.

The CIT system, also stand-alone, covers the complete range of AR-144 requirements. It is of some interest that trials of dynamic threshold have created some difficulty on noisy systems (whether of the motion or detecting accelerometer) in that the system will pick-up the first occasion of achieving 63% of commanded acceleration, which may be a noise spike, giving an unrealistically low answer.

A complete coverage of the AR-144 tests is rather a long exercise; for example 60 runs per driven axis would take about 30 min (so three hours for a six DOF motion system) to run the trials on both the SLM and CIT systems, and about twice as long to analyse and display. Equally, both systems allow the creation of a restricted range of runs which might be appropriate for periodic check-out, as distinct from initial acceptance, of a motion system.

Although not required in the original Specification the developed CIT system is capable of driving up to eight channels simultaneously, and therefore could in principal be used to drive a synergistic system. It has in fact been used to drive two channels simultaneously on the new AFS (Advanced Flight Simulator) at RAE Bedford.

There is ample space to accommodate the drive algorithms for the synergistic system but the computation of attitude, required for gravity correction, from leg position is more complicated and has not been considered so far; use of attitude gyros instead could be easily accepted.

The SLM system has been used on three different synergistic systems with easy transfer. The CIT system has been used on independent axis systems at RAE Bedford, three DOF (Redifon) system, at NASA, on a four DOF system and on the Vertical Motion Simulator, as well as recently on the Advanced Flight Simulator, five DOF, at RAE Bedford. Apart from difficulties due to the UK users ignorance on how to change the system to US voltage and frequency standards, no difficulties have been experienced in using the system. However, the incorporation of the gentle start-up and shut-down cycle was due to concern about violent transients on some of the early trials.

Apart from the drive to a synergistic system, two other simple enhancements to the CIT system would be desirable. A Hewlett Packard 9836, with its larger display screen would allow tidier programs and bigger display of results. A Winchester disk would give quicker access to data and eliminate any restriction on data file size.

Copyright © Controller HMSO London, 1985

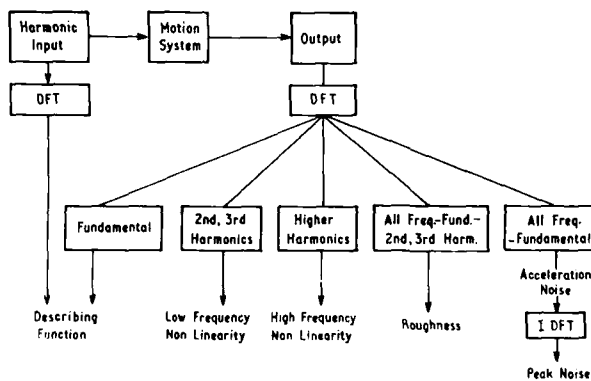

Fig 1 Motion Characteristics from DFT Analysis

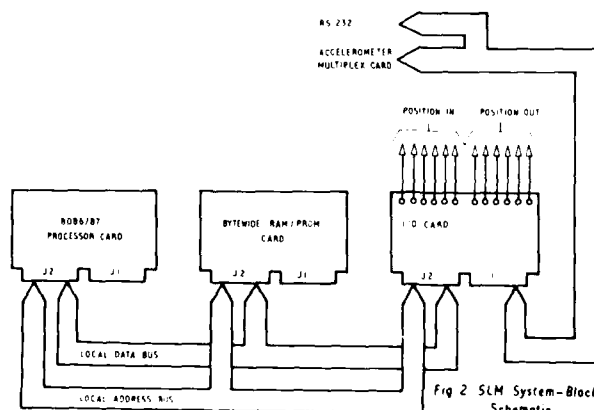

Fig 2 SLM System-Block Schematic

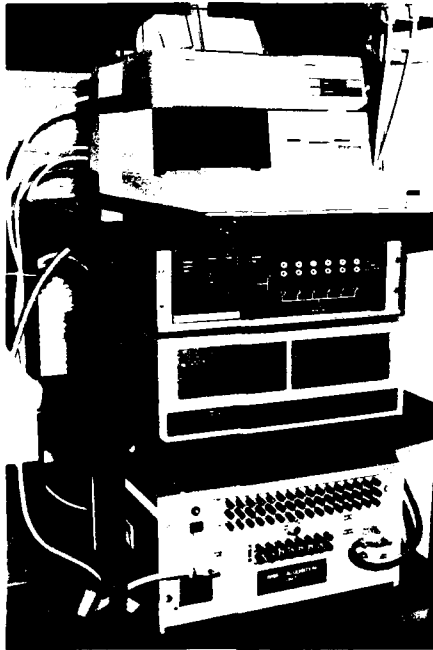

FIGURE 3. THE SYSTEM

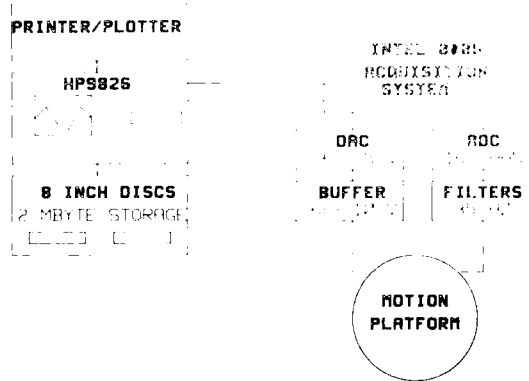
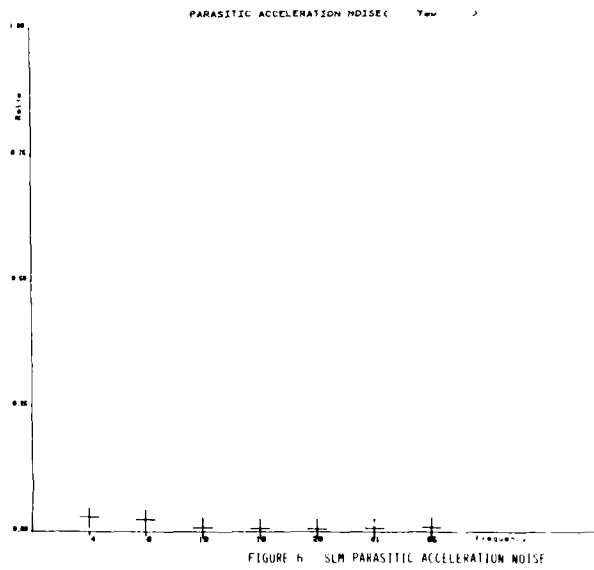
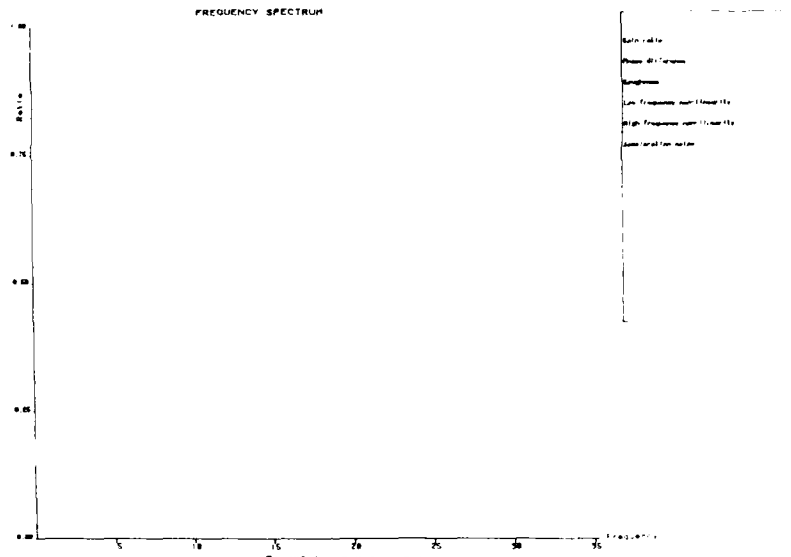

FIGURE 4. THE SYSTEM - BLOCK SCHEMATIC



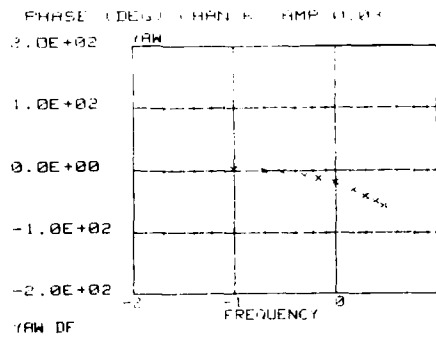
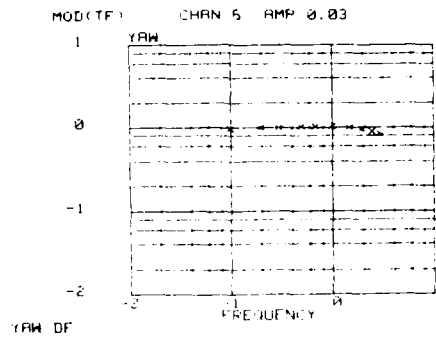

FIGURE 7 CIT DESCRIBING FUNCTION

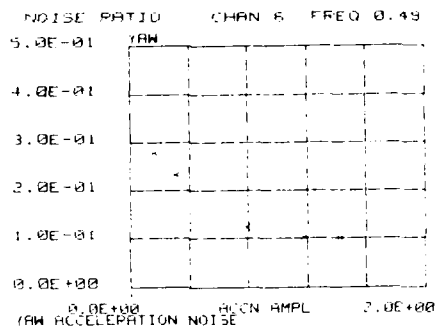

FIGURE 8 CIT ACCELERATION NOISE RATIO

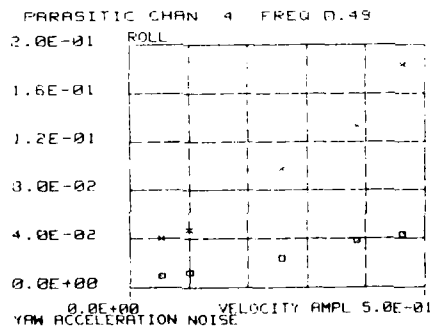

FIGURE 9 CIT PARASITIC ACCELERATION NOISE

**FLEXIBLE AND HIGH QUALITY SOFTWARE ON A MULTI PROCESSOR COMPUTER SYSTEM
CONTROLLING A RESEARCH FLIGHT SIMULATOR**

by

A.P.L.A.Marsman
National Aerospace Laboratory (NLR)
P.O. Box 90502
1006 BM Amsterdam
The Netherlands

SUMMARY

This paper deals with two requirements for flexible software for research flight simulation programs: the research environment and the aspects of the multiprocessor computer system.

The various research projects will always demand for modifications. Scheduling of these projects yields to parallel development of software and hardware. Interference between the projects due to software modifications is avoided by a hierarchical software environment, while simulation testruns can be performed independent from the hardware configuration at that time. Although software development is performed on the same computer, there is no need to stop development during simulator operation.

No heavy administrative system is ruling the quality of the software. Simple rules on quality assurance are adopted by the simulator group. During development a quality assurance system checks the overall integrity of the common-data used. The debug feature of this system appeared to be essential for the multiprocessor simulation program.

The multiprocessor system requires other flexibilities to be incorporated in the software. A scheduling system copes with the parallel processing restrictions of all subprocessors, and makes easy rescheduling possible.

Inner and outer frames are mentioned, for which the selection of the integration method is important minimizing time-delays. In this respect the remarkable fact is explained of simulating a fighter with FCS in an outer frame of 45 ms giving less delay than with 30 ms (both with an inner frame of 15 ms).

The single-computer multiprocessor system yields to a flexible simulation program of high quality standards, which makes this computer competitive with array processors.

1. INTRODUCTION

The National Aerospace Laboratory NLR operates a research flight simulator controlled by a Perkin Elmer PE 3200MPS multiprocessor computer system. The research areas investigated on this facility include pilot-aircraft integration, handling qualities, human engineering, advanced flight control systems, operational aspects and so on.

A single seat cockpit (fighter) as well as a side by side cockpit (transport aircraft) can be mounted on a four-degrees-of-freedom motion base platform. Television displays are installed on both cockpits giving a visual scene from a modelboard visual system. Besides the availability of electrohydraulic control loading systems research can be performed using a sidestick. At this moment NLR has a spring-force control system defined by a customer installed in the single seat cockpit. Several of the flight instruments can be exchanged, while mounting other scales on them will be a minor effort.

Independent of the hardware configuration at a particular time the simulation program for the F28 (or any other aircraft) can be operated. This means that the program incorporates all hardware options with different calibration tables as the most simple solution, since for example the drivelaws trimming the above-mentioned primary control systems are quite different for each system. Modularity of the simulation program allows the usage of subsets of the hardware. Any reasonable combination is possible, with or without motion, visual, flight instruments, etc. Even the primary controls can be replaced by inputs from a file. This enables the flexibility of parallel maintenance of hardware, while testing modified modules in the software. On the other hand it reduces the costs for the research projects which don't need all systems.

Although these options are already included in the simulation program, a research environment will always demand for modifications or additions. For this reason a flexible software development structure is provided taking into account the basic aspects of software quality as well, see chapter 2.

Real-time problems for an F28 simulation which might be disturbed by for instance the incorporation of a MLS computer, and the problems of simulating a fighter with a digital flight control system are of a totally different stage. A flexible system has been designed to optimize any simulation program on the multiprocessor computer which is discussed in chapter 3.

2. SOFTWARE DEVELOPMENT STRUCTURE

As the research areas cover a wide range of investigations, the flexibility of the software development must be secured. All different research projects are available on the same computer, but they shall not affect each other. Also restrictions must be met with regard to confidential data.

These requirements are met by the flexible software environment available on the multiprocessor computer. This environment enables parallel development of the research projects without any interference.

Software development can continue even during simulator operation. The multi-user operating system serves the real-time simulation program first and the other programs (compilers, testruns, plotting) in the spare-time of each time-frame.

In the next paragraph (2.1) the software environment is discussed which enables the parallel development of the research projects. Notwithstanding the inherent intensification of the software development one should not disregard the software quality assurance which is discussed in paragraph 2.2. A software package which deals with the quality assurance is discussed in the last paragraph (2.3) of this chapter.

2.1 Software environment

The software environment which enables the possibility for parallel changes consists of a hierarchical system of four levels (figure 1).

- Computer kernel system level: this level contains the FORTRAN-, mathematical-, IO libraries and other system programs.
- Basic simulation program level: the main simulation program and all standard simulation models (e.g. equations of flight, hardware drivelaws, wind & turbulence) are stored at this level and are usable for all projects.
- Aircraft model level: there are parallel accounts of sources and datafiles for each aircraft containing the specific aircraft models (aerodynamics, engines, etc.).
- Research project level: again there are separated accounts for each project on which the demanded changes and additions are stored. Each project level is linked to one of the aircraft model accounts.

The standard PE Multi Terminal Monitor (MTM) program as well as the simulation program are containing the logics dealing with these levels. For instance a specified datafile is first searched for at the research project level, if not found searching is continued at the aircraft model and simulation program structure level automatically. The task linkage editor will search for objects in the same way, but even up to the computer kernel level.

Software modifications at a particular project account don't affect the simulation programs of other projects. Nevertheless upgrading modules at higher levels does affect the subsequent project accounts. These problems are reduced as much as possible by implementing and testing the upgraded modules first at a project account.

2.2 Software quality assurance

Special attention must be paid to software quality assurance when modifications are implemented in such an intensive way. Of course a high level programming language is mandatory for software quality (FORTRAN-V, ANSI 1977). But also tricks to gain computational speed must be prohibited, conflicting with the real-time aspects of flight simulation. Both, good readable code assuring quality and high computational speed, are achieved by using the PE FORTRAN-VII "universal optimizer compiler" (Ref. 1). Furthermore the supervisor of the programmers is responsible for the software quality. When working in a team special agreements must be made. Some quality assurance rules applied by the NLR simulator group are summarized:

- Rules on sources: Modularity is very important for separating the different subjects in a simulation program (Ref. 2).
Describing the purpose, definition and interface of each module in a predefined layout (see the template mentioned in Appendix A) is a must for understanding the program later on and is beneficial when implementing customer defined modifications.
- Rules on data storage: The modularity on data storage is achieved by using a lot of labelled common-blocks.
One data location is used for only one purpose. Don't change data after reading it from a file, but use separate locations for converted data. Selection of unique symbolic names prevents misunderstanding by the programmers. The description of the symbolic names must follow the declaration immediately, while some conventions have been made with respect to the units (e.g. HSLFT for height above sealevel in feet).
The use of constants must be minimized, because they never will be as constant as one thought in the first place.
- Rules on input files: Standardisation of the layout (not only numbers in the files) is maintained strictly on all inputs.
A special read procedure checks the integrity of the files every time.
- Rules for configuration control: For every simulation run the selected options and files will be on the printout as well as on the simulation registration tape (see Appendix B).
- Archives (e.g. backup tapes) of all research projects must be kept. Predefined test-runs with debugging path procedures must be performed after any change.

Quality assurance performed by a supervisor is hard to be adopted by software specialists. Therefore checking on this matter by the computer is a better solution, the more so as no supervisor can be as accurate as a digital computer. Software quality is also upgraded if often repeated edit operations are performed by the computer. For these reasons a quality assurance system has been developed.

2.3 The common-data quality assurance system

The common-data quality assurance system (COMQAS) takes care of the integrity of the huge amount of common data storage and the usage of it by all program modules (Ref. 3). Over 50,000 data locations, with more than 4000 symbolic variable names is "common practice".

Three programs of the COMQAS system are discussed: the common-data definition program COMDEF, the pre-compiler COMVAR, and the common-data debug & monitor facility COMBUG.

- COMDEF: the type/dimension of symbolic names (single variables or array's) and their position within a labelled common block is defined only once in the common definition file. Reading this file COMDEF creates the COMQAS data-base which is used by all the other COMQAS programs. The common definition file contains labeled commons concerning the basic simulation program and the aircraft modules. The file is modified and extended with specific commons for each project. Appendix C shows one labelled common-block of the common definition file. As one can see, the variable MACH which should be in FORTRAN of type INTEGER by default, is defined by the code .R as type REAL. (Of course, all type declarations are possible, as well as more-dimensional arrays or parameter constants.) Since the best place of describing the variables is in this definition file, ample space is left for comment in each record while additional comment lines are possible also. The rules on data storage (see par. 2.2) are secured by COMDEF. It allocates data in labelled common-blocks and rejects multiple usage of a symbolic name.
- COMVAR: The precompiler COMVAR checks the usage of common variables names in the source modules. To be able to distinguish variables from other code or comment, COMVAR incorporates ANSI FORTRAN-V (1977). It generates the necessary code defined by COMDEF, and gives error and warning messages if discrepancies are encountered. Providing the declaration of common-block AREA2C (Appendix C) any occurrence of the symbolic name MACH in a module, will result in automatically generated FORTRAN statements:

```
REAL MACH
COMMON/AREA2C/RAR2C(32)
EQUIVALENCE (MACH,RAR2C(5))
```

The automatic type declaration for MACH being a REAL floating point, prevents a lot of problems, since the erroneous usage as an INTEGER value in any module is very difficult to be recognized and hard to be located.

By means of warning messages COMVAR encourages the common-blocks only to be declared when they are used in a module. Now it is possible to get just the affected modules from a common cross reference list, when a certain common (e.g. AREA2C) is to be modified.

Since EQUIVALENCE statements are only generated for the symbolic names encountered in a module, the total equivalence list will be a short but complete list of the variables used, enhancing the surveyability.

- COMBUG: As most debuggers do today, COMBUG communicates with the user by symbolic names displaying and modifying the common variables. Although COMBUG hasn't all debugger options (e.g. breakpoints), the main advantage of this program is that it doesn't need special compiler options, bypassing debugger overhead at preparation time and at execution time. And last but not least COMBUG is unique for dealing with parallel tasks on the multiprocessor system.

A subset of COMBUG is deriving the address of a variable specified by its symbolic name using the COMQAS data-base. This feature is applied also in the recording routines (mag-tape, multi-channel recorders) of the simulation program enabling very easy modification of the specification of the recording data list of symbolic names.

3. THE MULTIPROCESSOR SIMULATION PROGRAM

Apart from the research environment there is another requirement for flexible software at the NLR simulator. This concerns the optimisation of the multiprocessor system (MPS) for the real-time simulation application.

Figure 2 shows the multi-task configuration of the simulation program. The important centre of this figure is the shared memory block containing the COMMON data. All the communications between the subtasks is achieved by this block, while the management task is also using intertask-control commands.

Concentrating on the real-time process one recognizes three tasks performing this program phase: one CPU (Central Processor Unit) and two APU (Auxiliary Processor Unit) tasks.

Although everything happens in parallel during real flight, there are sequential restrictions in a digital simulation program in order to minimize the time-delays.

The next paragraph (3.1) deals with real-time synchronisation and sequencing of all subprocesses.

The second paragraph (3.2) explains the effects of integration methods used with respect to time-delays and the third one (3.3) in conjunction with inner and outer frames.

The last paragraph (3.4) concerns software quality aspects on the single-computer MPS. These aspects are compared with the usage of array-processors.

3.1 The real-time scheduling system

The real-time synchronisation for every frame is mentioned in figure 3. It is obvious that the CPU-task is the master, as it initialises for each frame the subprocesses scheduling tables, and synchronises with the real-time clock by means of a time-out. During this time-out other users might use the CPU, while the two APU's are dedicated to the simulation program.

Scheduling the subprocesses has a lot in common with project planning. A typical dependency scheme is outlined in figure 4. These dependencies are defined in a scheduling file together with the sequential assignments of each subprocess to the CPU, APU 1 or APU 2. Changing this file makes rescheduling possible at any time.

An automatic sequencing of the subprocesses is not implemented for two reasons.

First, since it might result in different sequences for different frames, creating a lot of extra difficulties, and a lot of calculation overhead.

The second reason is that we want to keep control ourselves about the critical path. The simulation program prints timing-diagrams on request, showing wait-times and execution-times of all subprocesses.

Nevertheless, automatic tests are performed before the real-time process is started. The given sequential assignments are checked for discrepancies with the dependencies.

Also the real-time test waiting for the predecessors, is automatically reduced to a maximum of two. Predecessors running in the same task are always completed when the start of a next subprocess is being tested. Hence predecessors assigned to the other two tasks have to be tested on completion. Due to the fixed sequence only the last ones assigned to each task have to be waited for, since previous predecessors have been completed also at that time.

3.2 Integration methods and time-delays

To prevent misunderstandings about time-delays it must be said that the pure time-delay discussed here, differs from a lag-time. The pure time-delay in flight simulation is the time that the visual and/or motion system do not react on a pilot input, since the computer needs this time calculating the new output signals for that pilot input. Smaller time-delays are not only achieved by installing faster computers, but also by the way of computations. Here the effect of the integration method is discussed (Ref. 4).

For explaining the time-delays due to the integration-method used, we will use a simple damped second order system. Or translating it to aeronautical terms, we may speak for example about the short period. Pitch attitude due to stick displacement inputs. The FORTRAN of the differential equation of such a system in vector notation reads:

$$\begin{aligned} \text{XDOT}(1) &= && \text{X}(2) \\ \text{XDOT}(2) &= -\text{W0}^{**2} * \text{X}(1) - 2*Z*\text{W0} * \text{X}(2) + \text{W0}^{**2} * \text{FI} * \text{XI} \end{aligned}$$

where: FI = input effectiveness factor
 X = the state vector
 XDOT = the time derivative of the state vector X
 XI = the input signal
 W0 = the undamped eigenfrequency of the system
 Z = the damping constant

For showing the effect of time-delays with respect to the integration method, we limit this discussion to two methods.

The first one, the Adams-Simpson method, is a pure vectorial solution, while the second one, the Second-Order-Adams with trapezoidal, needs resequencing of the vector element computations.

All the FORTRAN for the second order system with the Adams-Simpson method are:

$$\begin{aligned} \text{XDOTP}(1) &= \text{XDOT}(1) \\ \text{XDOTP}(2) &= \text{XDOT}(2) \\ \text{XDOT}(1) &= && \text{X}(2) \\ \text{XDOT}(2) &= -\text{W0}^{**2} * \text{X}(1) - 2*Z*\text{W0} * \text{X}(2) + \text{W0}^{**2} * \text{FI} * \text{XI} \\ \text{X}(1) &= \text{X}(1) + 0.5*DT * (3*\text{XDOT}(1) - \text{XDOTP}(1)) \\ \text{X}(2) &= \text{X}(2) + 0.5*DT * (3*\text{XDOT}(2) - \text{XDOTP}(2)) \end{aligned}$$

where: DT = the frame time
 XDOTP = the past value of XDOT

It is obvious that the result of element X(1) (= pitch attitude) is affected by a sudden step-input on XI only after TWO frames. This is shown in figure 5a with an additional delay of half a frame averaging input sampling, and compared with the reaction of an analogue system.

Reviewing the above FORTRAN, one can decrease this time-delay by resequencing the statements. The computations of the second element X(2) (= pitch-rate) are placed before all the computations of the first element X(1). Due to this resequencing the integration statement of X(1) has to be modified to get correct computations. This yields to the Second-Order-Adams-trapezoidal combination:

$$\begin{aligned} \text{XDOTP}(2) &= \text{XDOT}(2) \\ \text{XDOT}(2) &= -\text{W0}^{**2} * \text{X}(1) - 2*Z*\text{W0} * \text{X}(2) + \text{W0}^{**2} * \text{FI} * \text{XI} \\ \text{X}(2) &= \text{X}(2) + 0.5*DT * (3*\text{XDOT}(2) - \text{XDOTP}(2)) \\ \text{XDOTP}(1) &= \text{XDOT}(1) \\ \text{XDOT}(1) &= && \text{X}(2) \\ \text{X}(1) &= \text{X}(1) + 0.5*DT * (\text{XDOT}(1) + \text{XDOTP}(1)) \end{aligned}$$

Figure 5b shows the results of this method on a step input with a time-delay of 1.5 frames. Hence simple modifications in the way of computing gives better results with respect to time-delays. In the next paragraph the sequence of all computations in a complete (outer) frame is discussed regarding time-delays.

3.3 Inner and outer time-frames

When the eigenfrequencies of the simulated models are increasing, the computation update rate must increase accordingly, thus decreasing the frame time.

To achieve very small frame times (e.g. 15 ms for a fighter with FCS, 7.5 ms for hydraulic actuators or even less for helicopter blades), one can perform the computations of less critical parts just every 2 or 3 frames. Even the pilot input sampling and the control signals send to the motion and/or visual system are now becoming less important.

In that case we have inner frames (for the high frequency model computations) and outer frames (with I/O from/to the outside world).

One must be aware of using inner and outer frames, since the total time-delay from input to output is affected by all computations.

Figure 6 displays the inner and outer frame of a fighter simulation with digital FCS. For three inner and outer frames the FCS is computed by one processor while the aerodynamics and equations of flight are com-

puted in another, running in parallel just like the real world. Between input command (e.g. pitch stick displacement) and control surface actuator command, the FCS has two first order filters being integrated by the vectorial way explained in paragraph 3.2. Thus giving actuator commands after two inner frames of 15 ms.

The resequenced integration method is used within the actuator routines (two in parallel, serving the actuators 1 through 4 and 5 through 9 respectively). In addition these routines are running with a frame time of 7.5 ms, so the actuators are computed twice in each block shown. This results in changed aerodynamics in the third inner frame. Also the equations of flight and the motion washout (second order filters) are computed with the resequenced integration method. Thus a pull-up stick displacement gives an increased pitch attitude experience on motion and visual after three inner frames (= 45 ms).

The first thought of upgrading the simulation by using only two instead of three inner frames in an outer frame (decreasing it from 45 to 30 ms) has been contradicted. In that case the reaction upon an input is available after three inner frames and must wait for the fourth inner frame before output is gained (thus after 60 instead of 45 ms).

3.4 The single-computer multiprocessor system

The multiprocessor system (MPS) installed at NLR is one computer with several processors. Hence the programmers are dealing with only one operating system. There are no special restrictions with respect to the size of the shared memory block, or program memory available for a processor. All the processors can reach the total memory of 4 Mbytes now installed. There is no difference in programming language, neither are special compiler options necessary for CPU or APU tasks. All these uniformities are enhancing software quality and are prerequisites for the flexible scheduling system described in paragraph 3.1. Otherwise, switching a subprocess from one processor to another would become troublesome.

When the simulation program is not operative, the full capacity of the MPS is available for development and pre- and post-processing tasks.

Due to the universal optimizer compiler and the efficient indirect load and store instructions (used for table handling) the MPS becomes competitive with array-processors. A table lookup procedure of 30 aerotables is completed in 1.8 ms on the CPU (2.7 ms on the APU's) without the need for hard assembler coding job resulting in 1 ms execution time on a Floating Point Systems AP-120B array processor (Ref. 5). The benchmark for 30 second order damped systems (also Ref. 5) yields to .9 ms on the CPU versus .25 ms on the array processor programmed in the higher level language SIMPAL, but the MPS execution time will drop when a second order system function is available in micro-code. Next generation multiprocessors will incorporate more of the hardware architecture of array processors yielding to smaller differences in execution times.

After all, one must bear in mind that an array-processor is efficient for vectorial computations that might result in the problems discussed in paragraphs 3.2 and 3.3.

4. CONCLUSIONS

NLR is operating a research flight simulator in a flexible way in order to serve a wide range of investigations. Intensive software development for the various research projects can be handled with a minimum of interference or optimisation problems, while the modular design of all hardware systems yields to many configurations of the simulator.

Software flexibility with respect to the simulation hardware is achieved by incorporation of program options for the different hardware configurations (e.g. cockpits). Thus software testruns for one research project is possible while the hardware is configured for another project.

Parallel development of software for research projects is secured by the software environmental logics in a simple but effective way.

No heavy administrative system is ruling the quality of the software. Programmers private initiative of implementing new technologies is encouraged and possible by using private project accounts. These conditions are excellent for adopting a quality assurance system (Ref. 2).

The overall integrity check on common data by the COMQAS system is very helpful, upgrades the software quality and the efficiency of the programmers. It encourages the modular setup of labelled common-blocks and of subroutine modules.

But the COMQAS spin-off is coming from the COMBUG feature. This feature is unique for parallel tasks. Therefore we cannot debug the MPS simulation program without it.

Since every change in a subprocess effects the timing, it would be a pity if a redesign of the software is the result of it. Particularly because the exact timing can only be done after the correct implementation of all modifications. The available scheduling system is solving these problems in no time.

Smaller time-delays are not only achieved by installing faster computers, but also by making the computations more effective. The sequence of all computations must be taken into account, particularly of integration algorithms. The sequence is also important with respect to inner and outer frames, since shorter outer frames may result to larger time-delays.

The single-computer multiprocessor system yields to a flexible simulation program of high quality standards.

The benefits of execution time after cumbersome Assembler programming on an array processor are rather small compared with the MPS execution times. Attaching more APU's will be a better solution today for decreasing frame times, while the next generation multiprocessor systems will cope with future needs.

5. REFERENCES

1. FORTRAN VII Users' Guide 48-010 F00 R01. (Chapter 4). The Perkin-Elmer Corporation, Oceanport, New Jersey, 1983.
2. Seidensticker, S.: Modular Simulators, Their Feasibility, Design and Procurement, Logicon Inc. AIAA-85-0312, January 14-17, 1985.
3. Jonge, H.W.G. de.: A software package managing variables at system level (in Dutch) NLR MP 85013 U, National Aerospace Laboratory NLR, Amsterdam, 1985.
4. Heffley, R.K.; Jewell, W.F.; Whitbeck, R.F. and Schulman, T.M.: The Analysis of Delays in Simulator Digital Computing Systems, NASA-CR-152340, System Technology Inc. NASA Ames Research Center, Moffett Field, California, 1980.
5. Forsstrom, K.F.: Array Processors in Real-Time Flights Simulation, Northrop Aircraft Group, IEEE Computer, June 1983.

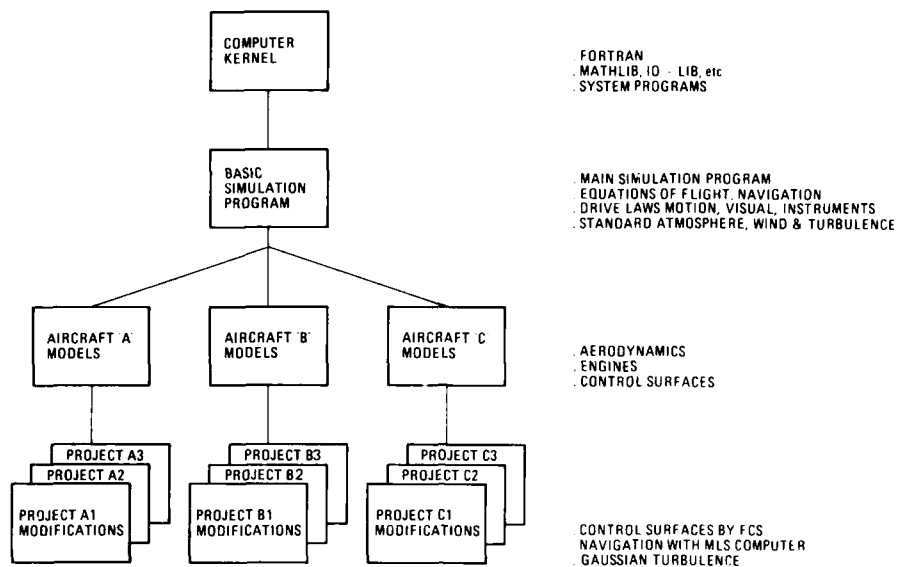

Fig. 1 Hierarchical structure of the software environment

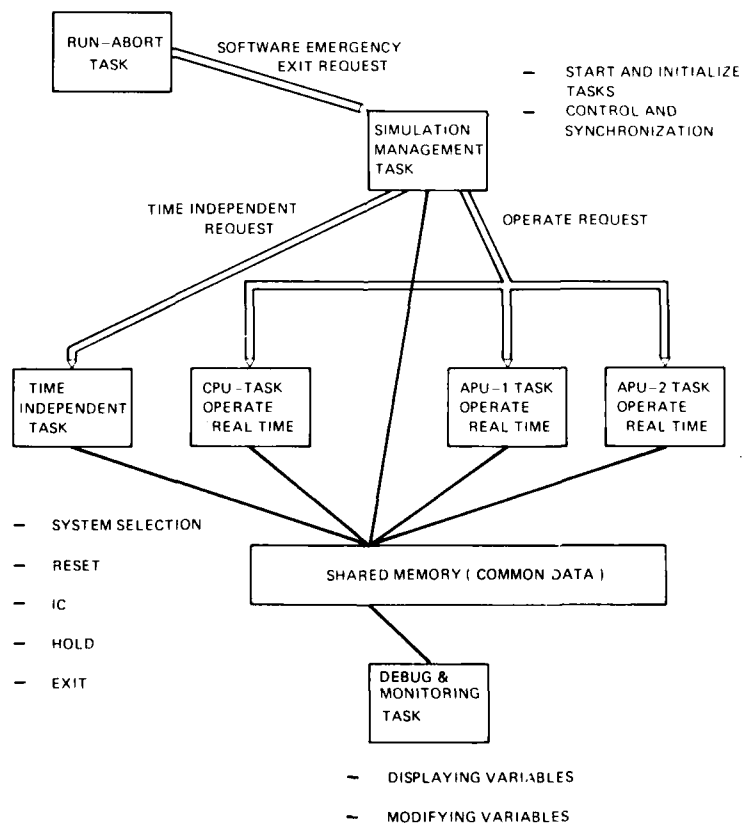

Fig. 2 The multi-task/multi-processor simulation program

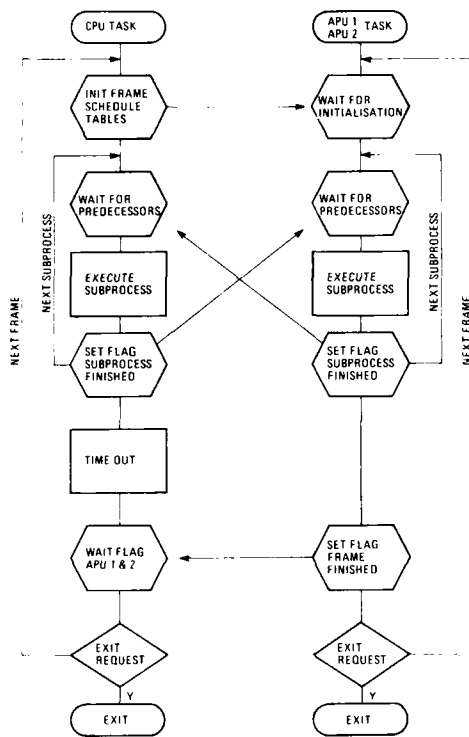

Fig. 3 Multi-processor real-time synchronisation

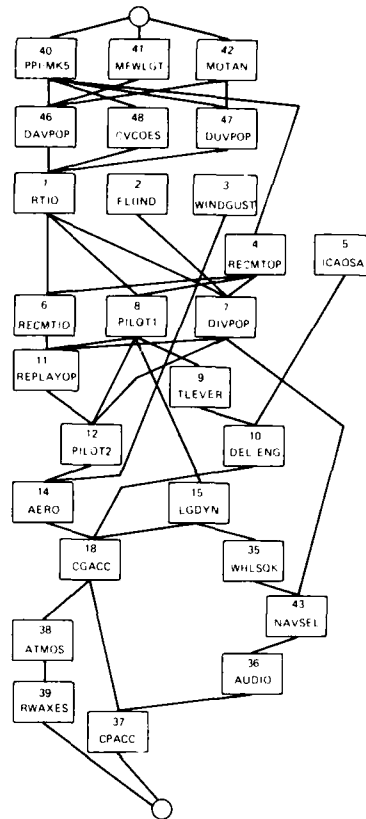
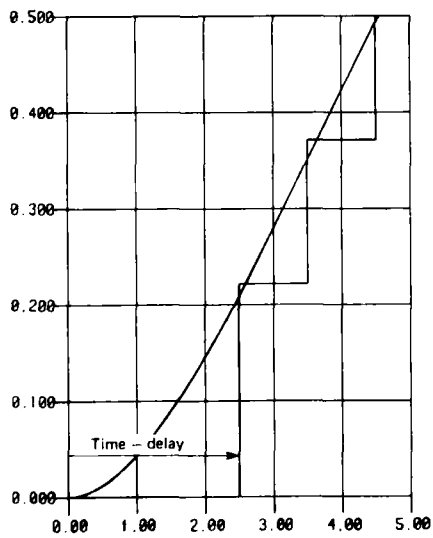
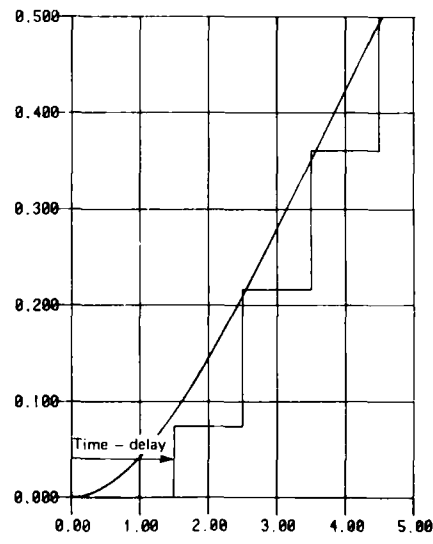

Fig. 4 Typical dependency scheme of subprocesses



a: Adams - Simpson Algorithm



b: Second order Adams trapezoidal combination

Fig. 5 Initial step-input response of a second-order damped system; the effect of digital integration algorithms

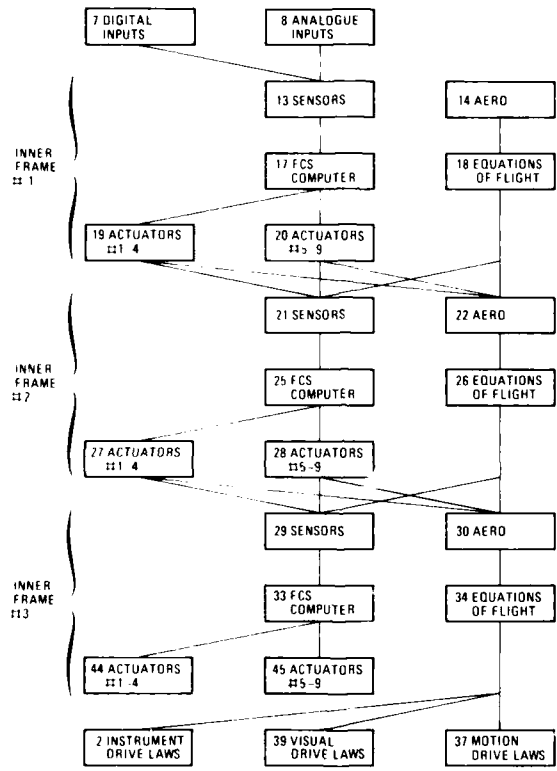

Fig. 6 One outer frame with three inner frames

APPENDIX A
A template to be used for describing subroutine modules

```

SUBROUTINE .....
-----
C#
C# Name      : .....
C# Purpose   : .....
C# Author    : .....
C# Date      : .....
C# Copyright : National Aerospace Laboratory N.L.R. (V5)
C# Manual    : .....
C#
C# Modification : .....
C# Author      : .....
C# Date        : .....
C#
C#
-----
C#
C# Calling Seq. : CALL .....
C#
C# Arguments      Name      Description
C# In             : .....      .....
C# Out            : .....      .....
C# In/Out         : .....      .....
C#
C# Files          Name      Description
C# In             : .....      .....
C# Out            : .....      .....
C# In/Out         : .....      .....
C#
-----
C#
C#
C# Declarations
C#
C#
-----
C#MMCN/BEGIN/
C#MMCN/END/
-----
C#
C# Process
C#
C#
-----
C#BEGIN:
C#-----
C#
-----
C#
C# Exit
C#
C#
-----
C#END:
C#----
```

APPENDIX B

Configuration Control: A printout of system-selections and files read

DATE: 26-JUL-85
TIME: 17:08:50

AIRCRAFT : F-28 MK6000
 PROCEDURE : A1
 PILOT NUMBER : 00
 PILOT NAME : STEP INPUTS
 SEQUENCE NUMBER : 1
 TURBULENCE : NO
 WIND-SHEAR : 01
 CODE-NUMBER : A100001401
 MAG.TAPE NR : 0107

- - - S Y S T E M S E L E C T I O N S - - -

CONTROL FORCES	2ND PILOT CONTROLS	MOTION SYSTEM	WASHOUT CALC.
FLIGHT INSTRUMENTS	NAVIGATIONAL AIDS	VISUAL SYSTEM	GRAPHICS TRANSLATOR
MAGNETIC TAPE	XY-PLOTTERS	PERFORMANCE CALC.	PRINTER OUTPUT
MF WARNING LIGHTS			

FILES READ FOR THIS INITIAL CONDITION IN RESET:

MSYS20	ACMD01	PROJ01	VALP01	NUC01	SLC01	MFP01	TIM01	ACS01	ACA01
EGS01	EGS01	EGP01	JCS01	UC001	ICT01	AF01	TR01	FS01	LG01
SP01	SB01	LCC1	SM01	Y001	GA01	FC02	TC02	FL02	TL02
SL02	LGC02	CMF01	ATH01	APL01	API01	NAV01	RWY01	ILS01	VCR01
NDS01	DMS01	HFC01	ATM01	SST01	FLI02	CLS02	MCT02	MKS01	AUD01
ANC01	GS301	RIOC1	XYP01	XY1P01	PFM01	PRT01	HLDI00		

FILES READ FOR THIS INITIAL CONDITION IN IC:

ICFP01	SHARD1	IC08	IM09	IP06	IT03	ISA01	WAC01	TR805	WASC1
VAR01	HTR01	USR01	STEP01						

APPENDIX C

A part of the common-definition file

```

/AREA2C/ :AERO-DYNAMIC PARAMETERS
1 .R PAR2C(32)
2 .R UBA :A/C airspeed X-body component [M/SEC]
2 .R VBA :A/C airspeed Y-body component [M/SEC]
2 .R WBA :A/C airspeed Z-body component [M/SEC]
2 .R VA :A/C airspeed [M/SEC]
2 .R MACH :Machnumber [ - ]
2 .R ALRAD :Angle of attack [RAD ]
2 .R BETAR :Angle of sideslip [RAD ]
2 .R ALFA :Angle of attack [DEG ]
2 .P SINAL :SIN of ALFA [ - ]
2 .R COSAL :COS of ALFA [ - ]
2 .R BETA :Angle of sideslip [DEG ]
2 .R SINBE :SIN of BETA
2 .R CJSBE :COS of BETA
2 .R PS :A/C roll-rate stab.axis [DEG/S ]
2 .R PY :A/C yaw-rate stab.axis [DEG/S ]
2 .R ALDOT :Rate of angle of attack [DEG/S ]
2 .R BETDOT :Rate of angle of sideslip [DEG/S ]
2 .P PSDOT :Deriv. of roll-rate stab.axis [DEG/S2]
2 .R ALFAIP :Angle of propulsion vector/airflow [DEG ]
2 .R STOW :Dynamic pressure [KG/M2]
2 .R STOWS :STOW * wing area [KGF ]
2 .R STOWSH :STOW * wing area [Newton]
2 .R UCA :A/C airspeed X-comp. stab.axis [M/S ]
2 .R B11 :Direction Cosine Body to wind axes system
2 .P B12 :
2 .P B13 :
2 .P B21 :
2 .P B22 :
2 .P B23 :
2 .P B31 :
2 .P B32 :
2 .P B33 :

```

COMPUTER SIMULATION STUDIES ON HUMAN CONTROL RELIABILITY

IN MANUAL AIRCRAFT CONTROL:
THE ORIGIN OF PIO

by

K. Brauser and R. Seifert
Messerschmitt-Bölkow-Blohm GmbH
Ergonomics and Cockpit System LKE 301
Postfach 80 11 60
D-8000 München 80
Germany

SUMMARY

Pilot Induced Oscillations usually are defined as a sensitive indication of bad handling qualities. In the view of human performance reliability, PIO's are related to input errors with respect to the control characteristics of the controlled system. It has been learnt that this is a special aspect of the general rule that man will make errors while performing an arbitrary task under the influence of possible "performance shaping factors" (PSF's).

A recently developed "Task Taxonomy Method" is used as a tool for the assessment of Human Error Probabilities (HEP) depending quantitatively on the effects of performance shaping factors (PSF) like task dimensions and characteristics, operator characteristics, system characteristics and environment factors. Using this Task Taxonomy procedure, HEP values for the manual aircraft control task have been calculated. HEP values are drastically increased (0.5 - 0.9) by the influence of bad handling qualities, while good handling qualities may only reduce the HEP value to 0.1, because other PSF's may remain still active. Therefore PIO incidents remain possible, even in aircraft with good handling qualities. This has been demonstrated by means of SAINT computer simulations using appropriate HEP values.

1. INTRODUCTION

Human performance reliability has been recognized as a key for the safe and error free operation of man-machine systems (MMS). Experiences have shown that systems equipped with high technical and safety standards, which are operated satisfactorily under normal conditions, may suddenly become unoperable under the impact of unusual performance shaping factors. An example best known has been the low coolant agent incident of the Three Miles Island nuclear power plant.

Other examples are PIO cases sometimes reported from flights concerning aircraft with good handling qualities validated, occurring at flight phases which may become critical by the pilot's task load /1/, /2/.

Since MMS designers and users have been confronted with the problems of the MMS operability, much research work has been done to develop strategies to control these problems. The best example is the increasing number of handling qualities criteria used in aircraft design /4, 5/. But still man's characteristics are not considered to the amount necessary. Though there are workload studies, and standardized rating questionnaires, there still are gaps in the knowledge of human working behaviour, especially with respect to human error probability (HEP).

The rising complexity of highly augmented aircraft has become a new problem for the formulation of extended handling quality criteria (/6/, /7/). Modern aircraft also carry more systems to be operated, which gives rise to increasing workload. These facts consequently demand for more automation in the cockpit area /10/.

In order to design a cockpit interface constellation for modern "superaugmented" /7/ aircraft with high degree of automation for error-free and error-tolerant operation, the dimensions of human error have become of main interest.

Therefore a literature survey has been made to get more knowledge of these dimensions. A huge amount of human error data have been published in the past. Also some trials of ordering these data by methods proposed by several authors have been made (e.g. Rigby /8/, Meister /9/, or Swain /3/). But, it was felt that the consolidation of these methods into a stronger and more extended procedure has become important.

While in the past, human errors have been categorized by many criteria in order to find a procedure to build a useful H.E.-databank, only a recently developed "Task Taxonomy Method" seems to promise some break-through /10/.

This method provides the handling of the HEP-problems by the following steps:

- 1) Assignment of HEP values measured, into 10 reliability classes, such providing an human reliability ordinal scale (Fig. 1)
- 2) Sampling and weighting of normalized task elements and performance shaping factors (Table 1)
- 3) Application of rules developed for the reconstruction of tasks from weighted task elements and performance conditions
- 4) Assessment of the HEP class and HEP values for arbitrary tasks under the influence of arbitrary performance shaping factors.

All these features of the task taxonomy method have been used for validation and prediction. It was the predictive power which has been set as a goal of this development, in order to use predicted HEP values as

- a) decision aids within cockpit/interface design procedures
- b) input data for special task computer simulations especially by means of the SAINT simulation programme.

2. THE TASK TAXONOMY METHOD

The Task Taxonomy Method which has been developed to get a systematic overview on human error problems, is based on the assumption that man will make errors while performing tasks.

Fig. 2 shows the observation points of human errors (HE) occurring when a human operator has to perform tasks in a man-machine system under the impact of any PSP.

Human errors can be observed directly only at his active interface (o). To such amount, they can also be observed indirectly at the controlled machine's output (+), but there HE may be masked by machine characteristics.

Fig. 2 also shows some "performance shaping factors" (PSF) which may generally refer to several areas of factors or conditions inducing errors.

While observing the occurrence of human errors at the control interface point (o) or - which requires more knowledge on the effects of errors on the system's performance - at the output point (+), the observer has to record all these factors of interest, say PSF 1 through PSF 5 (see Table 1).

Many authors have published relative human error frequencies or, after statistical treatment, Human Error Probabilities observed during the performance of carefully designed tasks and task environments. In most cases the PSF's have been specified. HEP values, reported up to now, range from below 0.0001 up to almost 1.0.

Though most reports combine HEP values with the description of these tasks, and the conditions of the task performance, it was almost impossible to detect quantitative relations between tasks and their respective HEP values directly. While qualitatively one can recognize the increase of HEP values when the "task difficulty" increases, measures to reveal the influences of all performance shaping factors quantitatively (task taxonomy) had not been developed yet.

The task taxonomy method presented here has turned out to become a complex set of procedures. Figure 2 demonstrates 5 areas of PSF which have to be taken into account:

- PSF 1: task dimensions, the analyzed time distribution of elementary human activities (5 items)
- PSF 2: task characteristics, such as complexity, difficulty, etc. (5 items)
- PSF 3: Personal factors, such as experience, attitude, etc. (5 items)
- PSF 4: Environmental factors, all influences from the work environment (7 items)
- PSF 5: System factors, all influences coming from MMS characteristics (7 items)

In order to get a first overview on the range of HEP values reported, one may assign these values into, say, 10 classes of HEP values, the so-called "reliability classes", RC. (Fig. 1). RC = 1 represents HEP values below 0.001, while RC = 10 represents those between 0.5 and 1.0. Thus at first an ordinal scale has been built which seems to be similar to the well known Cooper-Harper-Rating Scale, demonstrating that an increase of the RC range correlates with increasing "task difficulty" (whatever this means).

Other factors remained unrevealed, requesting the necessity of defining more performance shaping factors for weighting - at last up to 29 which are presented in Table 1.

The procedure of the "task equivalence" weighting method shown in Table 2 has been developed by trials on published data /11/. This method succeeded in the validation of such data. RC and HEP values are calculated accurately, when the authors of these data have described the task procedures and the performance shaping factors carefully to make accurate weighting of the PSF's possible.

This validation success gave rise to using the Task Taxonomy Method to predict RC and HEP values for new tasks to be designed, under the condition, that PSF's and their weights to be expected must be known.

Both the validation and the prediction procedures are almost the same (Fig. 3). This method appears to have all characteristics of an "Expert System", concerning theories, rules, algorithms, databanks, user procedures and expert data input features. A first test expert system has been set up and used to predict HEP values which will be encountered in arbitrary tasks concerning with the monitoring and control auf dynamic systems. It is based on a yet small list of 125 keywords for preweighted standardized activities, information sources and control tools to be used in such tasks /11/.

3. PREDICTION OF HUMAN CONTROL RELIABILITY

In order to achieve a valuable, predictive assessment of the HEP value for the manual aircraft pitch axis control tasks, a standardized task description has been made. Standardization of task description has been found to become necessary when the keywords to be used are assigned to preweights according to /11/. Having set the SAINT simulation run time to 20 seconds, it has been found that a time of 6 to 8 seconds is sufficient for a good recover from a pitch axis attitude disturbance.

Time weightings given in Table 1 for the tasks element distribution are achieved from normalizing the time values assessed for each of 8 standardized "subtasks", against the total simulation run time of 20 seconds:

- monitor system state (SCAN)	PERCEPTION
- detect (pitch axis) deviation	DETECTION
- compare (pitch axis) deviation	MENTAL OPERATIONS
- identify (dangerous) situation	MENTAL OPERATIONS
- assess recover procedure	MENTAL OPERATIONS
- decide (required) correction	DECISION
- control attitude with stick	ACTION
- read (while control) attitude	PERCEPTION

The normalized time distribution yields the value of 1.0 (Table 1) only if all these subtasks are performed serially. Since this task requires parallel subtask performance, namely for each of the subtasks "MENTAL OPERATION" and the PERCEPTION subtask "read attitude", the normalized time sum S_1 becomes 1.7 instead of 1.0 as an expression of a certain time stress.

The weightings of the PSF 2 group are assessed by several methods:

"CRITICALITY" = NUMBER OF SUBTASKS (= 8), divided by 10.

"DIFFICULTY" equals the average of all subtask difficulty factors, which are calculated from the subtask normalized time fractions multiplied by the difficulty preweightings. This procedure is described exactly in /11/.

"CORRECTIVITY" has been set to 0.5 because each control action may be corrected to a limited amount.

"TYPE OF TASK EVENT" has been assessed to be 0.6 because the disturbing event is rather random than predictable.

"CRITICALITY" has been assessed to be 0.5 because the risk of an accident following a control error is high during final approach.

The sum of the PSF 1 and PSF 2 weights are now found to be

$$\begin{aligned} S 1 &= 1.7 \\ S 2 &= 2.824 \end{aligned}$$

In order to get the HEP assessment for the whole task itself, the calculation of the task weighting is made by

$$W = S 1 * S 2 * (S 3 + S 4 + S 5)$$

Using the value $S 3 = 1.0$ for the "ideal operator", and $S 4 = S 5 = 0.0$, the result is

$$\begin{aligned} W &= 1.7 * 2.824 * 1.0 \\ &= 4.8 \end{aligned}$$

The reliability class is calculated by

$$RC = \text{INTEGER } (W) = 4$$

However, it is believed that the "ideal operator" would not exist, and giving the best operator ever met the chance of making an error, we assess his task attitude to sometimes a little deteriorated:

"ATTITUDE" set to 0.05

while the factors

"EXPERIENCE"
"SPEED"
"MOTIVATION"

should remain unweighted ("outstanding"), by the setting 0.0 for each.

The factor "OTHERS" has been found to be introduced by the weight 1.0 necessary to define the "ideal operator" not too far away from real life.

After the ATTITUDE weight has been set to 0.05, $S 3$ becomes 1.05 and

$$\begin{aligned} W &= 1.7 * 2.824 * 1.05 \\ &= 5.4 \end{aligned}$$

Now we have the task weighting for the "very good operator".

$$\begin{aligned} RC &= 5 \\ \text{HEP} &= 0.05 \text{ according to the class range from figure 1} \end{aligned}$$

This value has been measured by several authors sampled in /10/ to construct the reliability class assignments of figure 1.

The HEP values to be assessed from this method described are calculated by the following equation:

$$\text{HEP} = \text{HEP (RC)min} + (\text{HEP (RC)max} - \text{HEP (RC)min}) * \text{FRAC (W)}$$

while

HEP (RC)min is the lower HEP limit, and
 HEP (RC)max is the upper HEP limit of the respective RC range
 FRAC (W) is the fraction of the W value.

There are only few weighting factors left to deteriorate the HEP values further:

- 1) A pilot may be excellent but to a certain amount "unexperienced", e.g. with respect to the behaviour of a new aircraft type. If this EXPERIENCE weight is raised from 0.0 to 0.2, the resulting RC will increase to 6, and HEP will increase to 0.1.
- 2) If the PSF-4 weights VIBRATION and/or ACCELERATION are found to be accounted for by 0.5, because these may introduce unwanted inputs into the system (though described by "good handling criteria"), this gives rise to $S_4 = 1.0$ resulting in

$$\begin{aligned} W &= 4.8 * (1.05 + 1.0) \\ &= 9.48 \\ RC &= 9 \\ HEP &= 0.48 \end{aligned}$$
- 3) Handling Qualities, represented by the PSF-5 weightings for INTERFACES and FEEDBACK may result in similar RC and HEP values - for "very good" pilots - without any PSF-4 weights such as discussed above, being accounted for.
- 4) Workload weightings (TIME STRESS and/or MISSION DURATION of the PSF - 5 groups) may result also in RC = up to 10 and HEP = up to more than 0.5.
- 5) Combinations of PSF-4 and PSF-5 weights may have similar effects, resulting in high probability values near HEP = 1.0.
 This is demonstrated by the shaded areas of Fig. 1.

Such assessments of HEP the values of which have been reported by authors sampled in /10/ show clearly, that

- the manual aircraft control task during final approach is a difficult task,
- some performance shaping factors may influence the performance of human operators very effectively,
- good handling qualities of the aircraft may not prevent totally incidents like PIO, when some other performance shaping factors are still active.

The effects of small deteriorations of the (very good) pilot's attitude towards the manual control task, caused by arbitrary PSF's, are shown clearly by SAINT simulation runs, described in the following chapters.

4. THE SAINT SIMULATION OF MANUAL AIRCRAFT PITCH AXIS CONTROL

4.1 The state variable calculation

Fig. 4 represents the closed loop characteristics of the control task simulated. These characteristics are retransformed into a set of adequate differential equations, the solutions of which are provided by the SAINT program by means of a set of "Runge-Kutta-England"-integration subroutines (RKE).

The aircraft pitch axis (short period) characteristics are expressed by the inhomogenous differential equation

$$(1) \quad \ddot{q} = \omega_{sp}^2 (K_a (\delta_e + T_\alpha \delta_e) + F(T) - q) - 2\zeta_{sp} \omega_{sp} \dot{q}$$

while another second order equation describes the linearized elevator function (see also Fig. 4)

$$(2) \quad \ddot{\delta}_e = \omega_e^2 (K_c (\delta_s) - \delta_e) - 2\zeta_e \omega_e \dot{\delta}_e$$

This elevator model is linearized by the condition

$$(3) \quad \delta_{emin} < \delta_e < \delta_{emax} \quad ; \quad |\dot{\delta}_e| < |\dot{\delta}_{emax}|$$

The RKE subroutines provide numerical solutions of δ_e also for the cases $|\dot{\delta}_e| = |\dot{\delta}_{emax}|$ and $\delta_e = \delta_{emin}$ or δ_{emax} which means that also nonlinear characteristics are modelled with a satisfactory degree of accuracy.

The - simplified - loop modeling is completed by a modified equation for the stick movement

$$(4) \quad \ddot{\delta}_s = \omega_k^2 ((1/\bar{K}^*) \hat{\delta}_s - \delta_s) - 2\zeta_k \omega_k \dot{\delta}_s$$

$$\dot{\delta}_s = \hat{0} + (Tv_1 + Tv_2) \dot{q} + Tv_1 Tv_2 \ddot{q}$$

$\hat{0}$, \hat{q} , and $\hat{\ddot{q}}$ represent the differences of these respective steady state and disturbed state variables.

\bar{K}^* is the pilot's choice of a "complex gain" factor used to compensate the aircraft's second order characteristics ω_{sp} and ζ_{sp} together with the application of the two lead terms $1 + Tv_1$ and $1 + Tv_2$ according to handling criteria developed in /12/.

Again, the linear solution of equ. (4) is achieved for the conditions:

$$(5) \quad \delta_{smin} < \delta_s < \delta_{smax}$$

while a numerical solution is provided by the RKE-subroutine for the nonlinear limits $\delta_{smin} = -0.5 \delta_{smax}$

The values of ω_k and τ_k used in equ. (4) are derived from the combined characteristics of the stick and the pilot's active limb (/12/, /13/), calculated from

$$(6) \quad \omega_k^2 = (\bar{K} * K_p K_c K_a) / \bar{K} T_N$$

and

$$(7) \quad 2\tau_k / \omega_k = \bar{K} / (\bar{K} * K_p K_c K_a) - (\tau_p + \tau_c + \tau_a) / 2$$

K has been derived from a precision limb-manipulator model /13/ and may have a value of $1.5 = K = 3.0$, while T_N has a value of about 0.1 sec according to the wellknown, neuromuscular lag term introduced by McRuer /7/.

The system represented by the 3 equations (1), (2), and (4) is destabilized by the disturbance function

$$(8) \quad F(T) = 0 \text{ for } t < t_0 \text{ sec.}$$

$$F(T) = 0.5(1 + D(\Delta t) e^{-(t-t_0)}) \text{ for } t > t_0 \text{ sec}$$

while $D(\Delta t)$ is a random function chosen every $\Delta t = 0.1$ sec from a uniform random number distribution - 0,1 to + 0,1.

After the impact of $F(T)$ the task of the pilot is to compensate the effect of $F(T)$ that is to reduce θ , q and \dot{q} to zero, as soon as possible.

4.2 The SAINT task network

The state variable calculation described above is performed by the SAINT program as a continuous task. In this program PILOT this continuous task has the name AIRCRAFT (Fig. 5).

The elevator-aircraft state variables remain steady when the values of $F(T)$ and δ_s are zero. Excitation of equ. (1) and (2) by the introduction of $F(T)$ have to be damped and compensated by means of the control stick force/deviation function $\hat{\delta}_s$, which is applied only when the discrete tasks CONTROL or CONTERR are called up (Fig. 5).

This is done by the modification of the term

$$\dot{\delta}_s = \hat{\theta} + (Tv_1 + Tv_2) \hat{q} + Tv_1 Tv_2 \dot{\hat{q}}$$

of equ. (4) by means of "switch functions" provided by the SAINT program.

$$(9) \quad \hat{\delta}_s = IS(2) \hat{\theta} + IS(3) (Tv_1 + Tv_2) \hat{q} + IS(4) Tv_1 Tv_2 \dot{\hat{q}}$$

and

$$(10) \quad \ddot{\delta}_s = IS(1) \dot{\delta}_s$$

The switch IS(1) is set to zero if no pitch axis deviation has been recognized. After introduction of F(T) a deviation will be recognized when exceeding a pre-determined threshold. In this case, the task SCAN will be cut off and the task DECIDE is called up, setting IS(1) to 1.0 indicating that the pilot is ready for control. But, he has to decide which control strategy has to be chosen. Only for simplicity of the simulation set-up, the task DECIDE sets the switch-functions IS(2), IS(3), and IS(4) to 1.0 each, for the right control strategy. The SAINT branching from the task DECIDE to the task CONTROL and DECIERR is a probabilistic branching. According to the HEP value assessed by the taxonomy method, the branch DECIERR (decision error) is chosen by the probability HEP 1 while the branch CONTROL is chosen by the probability 1-HEP 1. It is this feature of the SAINT program which enables the model designer to introduce human error into the simulation.

If the task CONTROL was chosen, the switches IS(2), IS(3), and IS(4) set by DECIDE remain unchanged. This means that the pilot uses the best control strategy modified only by the handling qualities.

If the task DECIERR is chosen by the probability HEP, the switches IS(2), IS(3), and IS(4) are set to scaling factors deviating from the ideal value 1.0.

Finally, a probabilistic branching by HEP 2 is introduced in order to branch the task network from DECIERR to CONTERR (1-HEP 2 to control the pitch axis by false strategy) or back to SCAN (HEP 2). While the value HEP 1 is the general error probability for the total task calculated by the taxonomy method, HEP 2 may balance this probability between the important errors "perception failure" or "decision for erroneous strategy".

The control task termination is indicated by CONTENTD which SAINT-task is reached from CONTROL or CONTERR when the state variables return to wanted steady values (conditional branching). CONTENTD returns the pilot's activities back to SCAN by deterministic branching. One iteration of this simulation may be terminated after 20 seconds (Fig. 5).

It should be stressed that this simulation model cannot be used as "proof" for the pilot's "control reliability" (value 1-HEP1) which in fact has been calculated by means of the task taxonomy method. But it is a good tool to look for consequences of several types of error. One type is the control by erroneous strategy which means in some cases "PIO", in other cases "pumping" which may exceed the time left to correct the pitch position before touch-down, resulting then in a "hard touch-down" situation. Another type of error is "to do nothing" until a nice "pitch-up" results. There are also other possible errors resulting in a "time to recover" to the correct position longer than allowed by the situation.

The demonstration of the consequences of the two errors "false strategy (false a/c model)" and "do nothing", as intended, succeeded by the application of this simple SAINT model. The false strategy is simply introduced by the scaling factors IS(1), IS(2), IS(3), and IS(4) and is discussed below.

5. RESULTS

5.1 Human reliability classification for the task

The reliability class assessment performed by means of the task taxonomy shows clearly that the human reliability will remain within the classes 6...10 for the undoubtedly difficult task of the manual pitch-axis control. A general result is that human reliability for this task is limited to classes 6...10, which means that only a few influencing factors may shift the RC from 6 to 10.

For poor handling qualities Table 1 reveals the most important factors:

interface/controls
information feedback
system reliability

which are correlated directly to the handling quality criteria. "Poor" handling qualities may cause a human error probability assigned to the RC 8 through 10 even for experienced test pilots which means that every input made by the pilot is expected to become erroneous, destabilizing the system further, since the information feedback will demonstrate strange characteristics unknown to the pilot at first.

For good handling qualities normally the system may accept pilot's errors without reacting too much to erroneous inputs. In fact, the system's reliability is then expected to be as well as the reliability of the pilot. However, again only a few factors may deteriorate the pilot's reliability (Table 1):

safety risks (e.g. obstacles in glidepath)
threats (by turbulences)
time stress (only few seconds given for recovery)

Again these factors may shift the pilot's performance for reliability class 8...10 which means that consequences like PIO or hard touch down may occur.

5.2 SAINT simulation of control stick input errors

The RC and HEP values calculated by the task taxonomy method are general probability values concerning arbitrary input errors which will probably occur during performances of the specified task. Depending on the task there are several kinds of errors the relative weight of which may depend on the most contributing PSF's.

- Erroneous control strategy (choice of the false a/c characteristics or "model")
- Failing to make control inputs at the right time
- Stick inputs with inadequate gain.

Such input errors can be introduced into the SAINT simulation by means of the scale factors IS(1) through IS(4), described in chapter 4.2 for equ. (10). We have learnt from the SAINT simulation runs using the combination of IS (.) values sampled in Table 2 that these combinations are typical for well known MMS-performance errors, like

- PIO (feedback mismatched)
- Pitch up/down (failed to counteract)
- overshoot (input gain too high)
- pumping (input gain too low, or feedback mismatched)

There may be several other combinations of the input parameters IS(1)..IS(4) resulting in certain MMS performance characteristics. The SAINT simulation set up as specified above has helped to get insights into the effects of simple input error parameters on the MMS performance. Illustrations are given by the SAINT output records shown in Fig. 6 through 10.

6. DISCUSSION OF THE RESULTS

Two independent methods have been applied to analyse and demonstrate the effects of human error on the performance of an MMS.

The task taxonomy helps to assess the human error probability (HEP) for any task specified and provides the prediction of probability and type of error to be expected.

The SAINT simulation reveals the demonstration and prediction of the effects of these errors on the output performance of the MMS which is typical for the specified task.

The most important result of the task taxonomy HEP calculations for the specific task of manual pitch axis control is the following:

PIO incidents are basically depending on the Pilot's control reliability which at best will be of class 5 (HEP = 0.1). Any disturbing factors of difficulties will impair this control reliability up to 8 or even 10. (e.g. by bad handling qualities alone). The dependance of HEP (as the direct cause of PIO) on many performance shaping factors show clearly that PIO has to be looked at being a symptom only, pointing at causes behind, which are PSF's like handling quality criteria, time stress or others. The total consequences have to be drawn now.

A new insight into the effects of probable types of error has been gained by the accompanying SAINT simulations. PIO's may be induced by control strategies deviating only by small amounts from those required. This gives raise to the question of how the pilot should be informed best to avoid such deviations in each situation.

The basic expression for the strategy of control stick actuation was eq. (9):

$$\ddot{q} = IS(2)\ddot{q} + IS(3)(Tv_1 + Tv_2)\dot{q} + IS(4)Tv_1Tv_2\dot{q}$$

which is the term describing the feedback of the system's theoretical reaction to inputs set by the IS(.)-scales. This is the domain of better system dynamics feedback, e.g. by visual displays with adequate lead characteristics, and/or better stick feel feedback.

Other factors, distorting the control strategy to a certain amount but which have been held constant during these simulations, are represented by eq.(4):

$$\ddot{\delta}_s = \omega_k^2 \left(\frac{1}{K^*} \hat{\delta}_s - \delta_s \right) - 2\zeta_k \omega_k \dot{\delta}_s$$

namely, the complex gain factor $1/\bar{K}^*$, and the man-manipulator second order characteristics ω_k and ζ_k .

While K^* expresses the matching of $\zeta_{sp} < 1.0$ by some gain modulation, ω_k and ζ_k is set by the pilot as optimal as possible to reduce amplitude losses or stick-limb overshoots, and phase shifts. Limits are defined by the characteristics of the mechanical stick system. (Explained in /13/, /14/).

In order to avoid input errors as far as possible, it is believed that better feedback of system dynamics as well as the compensation of the distorting characteristics of the stick feel system can be established optimally by means of an "active control stick" (see /15/).

7. CONCLUSIONS

Severe inflight incidents caused by PIO or pitch-up, are deduced consequently from human control reliability.

This "human performance reliability" (HPR) is represented most impressively by the Human Error Probability (HEP) by the expression

$$HPR = 1 - HEP$$

Values of HEP are calculable by means of the task taxonomy method and have been found to be at least = 0.1 for the manual pitch axis control task (conventional unaugmented or augmented control system), and increasing quickly up to more than 0.5 under the influence of "performance shaping factors" like

- handling quality criteria
- system reliability
- information feedback gaps
- task event type
- time stress
- external threats
- high safety risks.

The HEP value calculated is the probability for the choice of erroneous control strategy demonstrated for at least four strategic control parameters. Since these parameters have to be assessed and set by the pilot, he should be supported by better presentation of these parameters to be used in any control situation.

The introduction of an active control stick system is seen to become the best means of support.

5. REFERENCES

- /1/ Neal, T.P. and Smith, R.E.: An Inflight Investigation to Develop Control System Design Criteria for Fighter Airplanes. AFFDL-TR-70-14, Vol. I and II, 1970.
- /2/ Some MRCA incident reports.
- /3/ Swain, A.D. and Guttman, H.E.: Handbook of Human Reliability Analysis with Emphasis on Nuclear Power Plant Applications NUREG/CR-1278 (1980) Sandia Laboratories, Albuquerque, NM, 97185.
- /4/ N.N.: Military Specification, Flying Qualities of Piloted Airplanes, MIL-F-8785 C, 5 November 1980.
- /5/ Schuler, J.M. and Dahl, M.A.: Proposed Revision to MIL-F-8785 C Related to Flight Safety of Augmented Aircraft, Vol I through III AFWAL-TR-82-3014, I...III, April 1982.
- /6/ Hodgkinson, J., LaManna, W.J., and Heyde, J.L.: Handling Quality of Aircraft with Stability and Control Augmentation System - a Fundamental Approach. Aeronautical Journal, Febr. 1976.
- /7/ McRuer, D.T.: Progress and Pitfalls in Advanced Flight Control Systems Paper No. 1, AGARD Conference Proceedings No. 321, on GCP Sympos. Lisbon, 12 - 14 October 1982.
- /8/ Rigby, L.V.: The Nature of Human Error. Sandia Laboratories, SC-DC-69-2062, October 1969.
- /9/ Meister, D.: Methods of Predicting Human Reliability in Man-Machine-Systems. Human Factors, 6, June 1964.
- /10/ Seifert, R., Brauser, K., Streubel, S.: Methoden zur Ermittlung der menschlichen Zuverlässigkeit bei Bedienung von technischen Systemen. MBB-Report FE301/S/STY/060, 28.2.1984.
- /11/ Brauser, K., Seifert, R.: Methoden zur Ermittlung der menschlichen Zuverlässigkeit bei Bedienung und Wartung. MBB-TN/S/95, 6.5.1985.
- /12/ Neuhuber, W., Diederich, L., and Brauser, K.: Handling Qualities Criteria for Longitudinal Control. Paper No. 8, AGARD FMP Symposium on Criteria for Handling Qualities of Military Aircraft, Fort Worth, Tx, 19 - 22 April 1982.

- /13/ Brauser, K.: Theoretical Linear Approach to the Combined Man-Manipulator System in Manual Control of an Aircraft. Report held on the 17th Annual Conference on Manual Control, UCLA, Los Angeles, CA, June 16 - 18, 1981.

- /14/ Brauser, K.: The Derivation of Handling Qualities Criteria from Precision Pilot Model Characteristics. Paper presented at the IFAC/IFIP/IAE Conference on Analysis, Design, and Evaluation of Man-Machine Systems, Baden-Baden, W.Germany, 27 - 29 Sept. 1982.

- /15/ Bubb, P.: Aktive Sticks - Theoretischer Vergleich unterschiedlicher Konzepte. MBB-TN-0080/84, 10.4.1984

- /16/ Magdaleno, R.E., McRuer, D.T.: Effects of Manipulator Restraints on Human Operator Performance. Techn. Rep. AFFDL-TR-66-72 (Dec. 1966).

PERFORMANCE SHAPING FACTORS (P.S.F.)	WEIGHTING			PERFORMANCE SHAPING FACTORS (P.S.F.)	WEIGHTING		
	SCALAR	0.5	1.0		SCALAR	0.5	1.0
ENVIRONMENTAL FACTORS				ENVIRONMENTAL FACTORS			
CLIMATE				CLIMATE			
ILLUMINATION				ILLUMINATION			
CONTAMINATION				CONTAMINATION			
NOISE				NOISE	Disturbance		
VIBRATION				VIBRATION	light moderate		0.0 to 1.0
ACCELERATION				ACCELERATION			0.0 to 1.0
EXTERNAL THREATS				EXTERNAL THREATS			
Sum of weights				Sum of weights	5.4		0.0 to 1.0
SYSTEM FACTORS				SYSTEM FACTORS	Handling Qualities		
INTERFACES / TOOLS				INTERFACES / TOOLS	2000 1000 1000		0.0 to 0.6
INFORMATION FEEDBACK				INFORMATION FEEDBACK			0.0 to 0.4
SYSTEM SAFETY				SYSTEM SAFETY			
SYSTEM RELIABILITY				SYSTEM RELIABILITY	Workload		0.0 to 0.2
MAN-MACHINE INTERACTION				MAN-MACHINE INTERACTION	light moderate		0.0 to 1.0
WORKLOAD				WORKLOAD			0.0 to 1.0

Table 1: Schematic weighting format of the task taxonomy method. The weighting procedures are described in chapter 3.

IS(:) No.	IS(:) value	Meaning of IS(:) value setting	Resulting MMS performance	Figure
1 2 3 4	1.0 1.0 1.0 1.0	Adequate gain (normalized) Adequate $\theta - n_z$ -feedback Adequate lead well matched to ζ_{sp} Adequate stick matched to CAP ¹⁾	Optimal performance	6
1 2 3 4	≥ 1.0 1.0 1.0 1.0	Gain higher than required Adequate matching	Overshoot, longer time-to-recover (danger of PIO onset if HQ poor)	7
1 2 3 4	1.0 ≥ 1.0 0.8 0.8	Adequate gain Overemphasized $\theta - n_z$ -feedback Lead mismatched to ζ_{sp} Stick force mismatched to CAP ¹⁾	PIO even with good HQ	8
1 2 3 4	1.0 0.5 0.9 0.8	Adequate gain Understated $\theta - n_z$ -feedback Lead almost matched to ζ_{sp} Stick force mismatched to CAP ¹⁾	Pumping, long time-to-recover	9
1 2-4	0.0 —	Control action omitting in time without effect	Pitchup, pitchdown possible	10

Table 2: SAINT simulation results of pitch axis control performance deterioration, caused by erroneous control strategies set by the SAINT IS(:) - values.

1) CAP = Control Anticipation Parameter

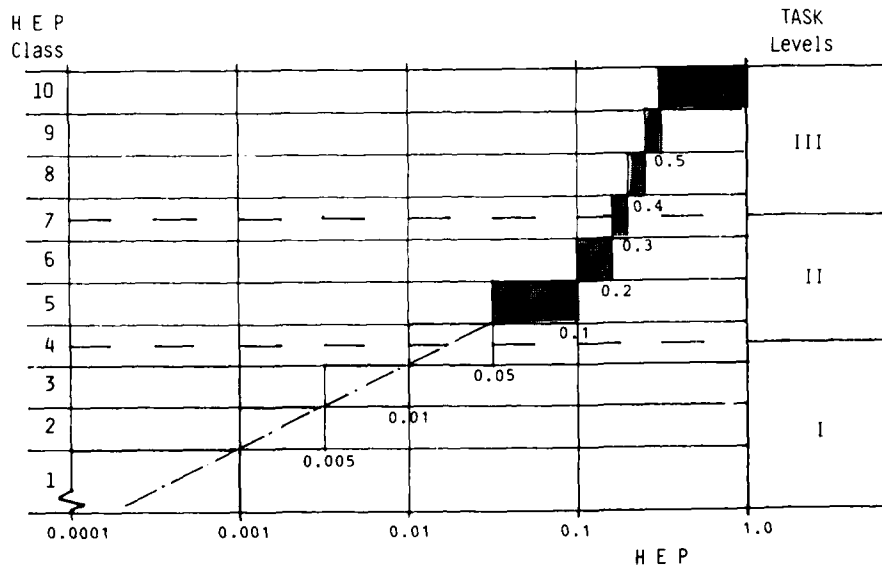

Figure 1: The Human Reliability Rating Scale (10 reliability classes), used for task performance reliability rating, similar to the Cooper - Harper rating method. The shaded areas are the range of human error probability for the manual control task.

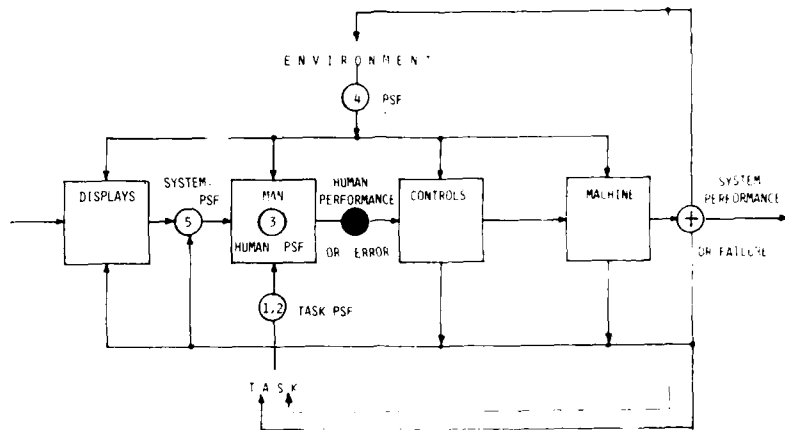

Figure 2: Observation points of Human Error (HE) in Man-Machine Systems, and influence regions of Performance Shaping Factors (PSP)

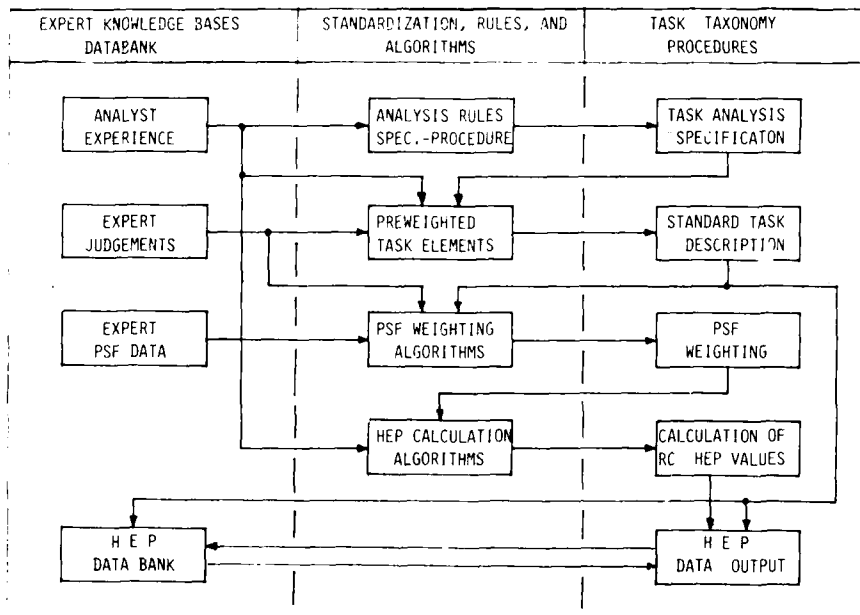

Figure 3: Schematic diagram of the Task Taxonomy procedure, an expert system concept.

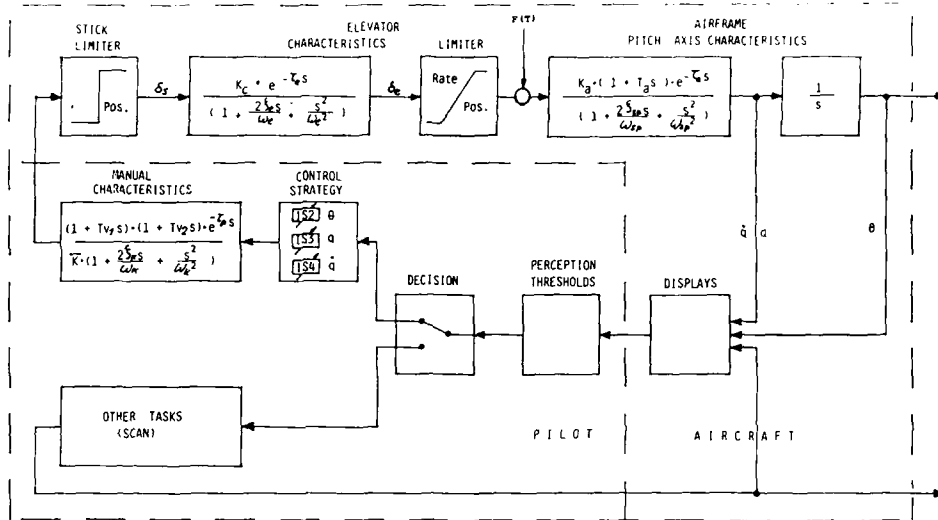
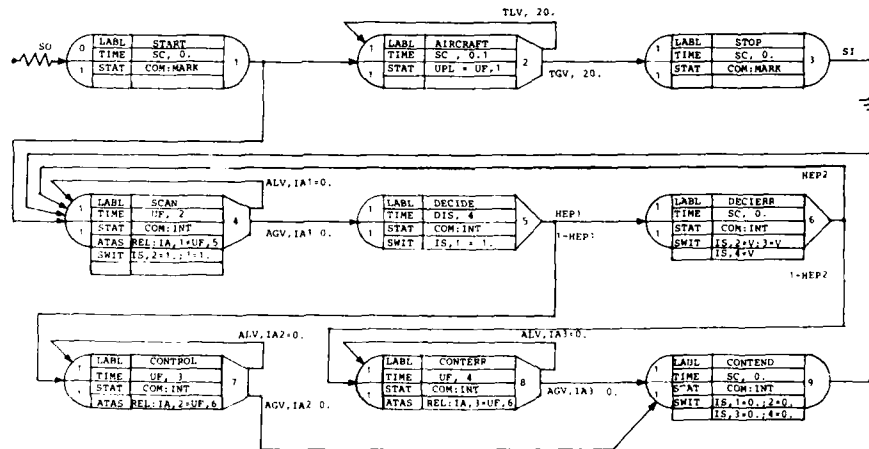

Figure 4: The closed loop model of the manual aircraft pitch axis control, used in the SAINT simulation described in the text.



Legend : HEP 3 = HEP 1 * HEP 2 . probability of control omission
 HEP 4 = HEP 1 * (1 - HEP 2) . probability of erroneous control strategy
 HEP 1 and HEP 2 are auxiliary values for calculation of HEP 3 and HEP 4.

Figure 5: The main SAINT simulation program described in the symbolic SAINT language.

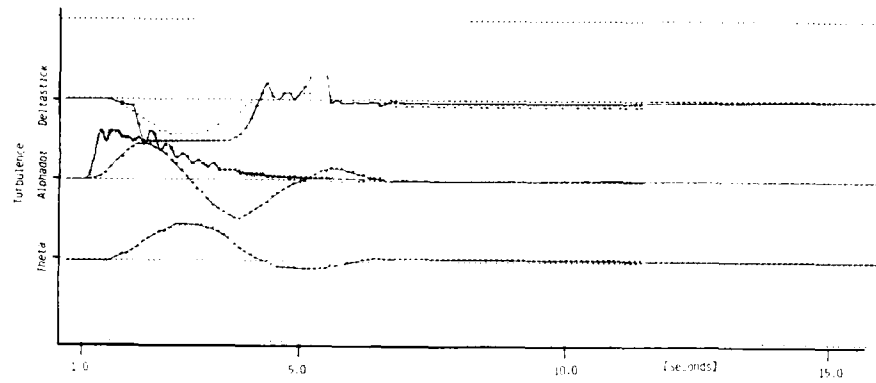

Figure 6: SAINT simulation plot: Optimal task performance, time to recover is 6 seconds

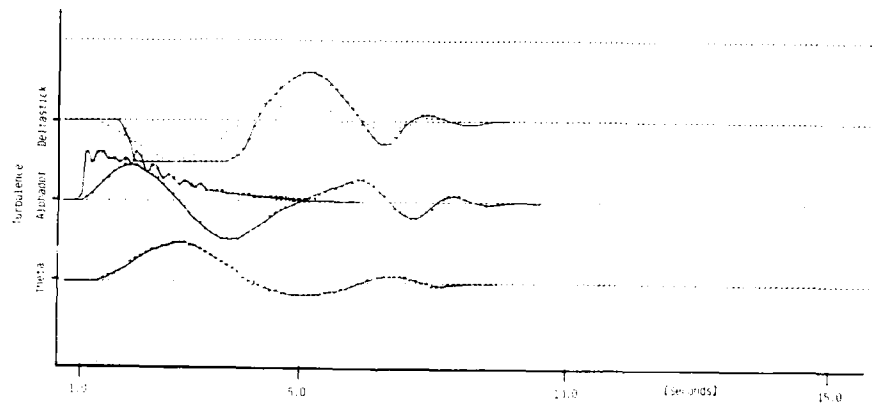

Figure 7: SAINT simulation plot: Stick input overshoot, time to recover increased to 8 seconds

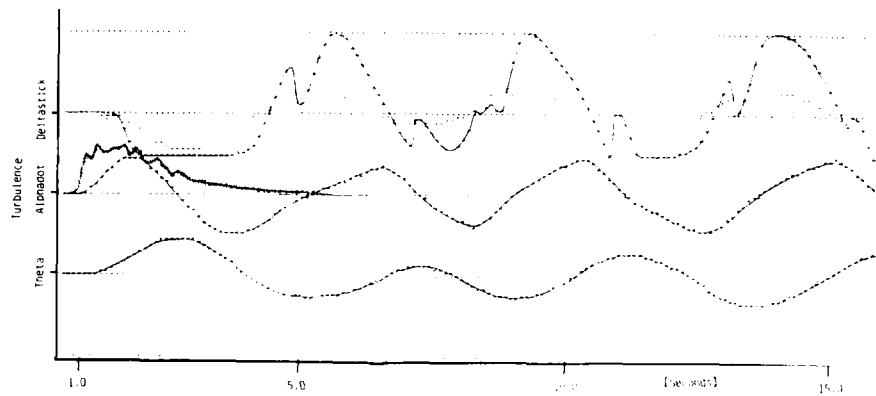

Figure 8: SAINT simulation plot: Pilot induced oscillation (PIO)

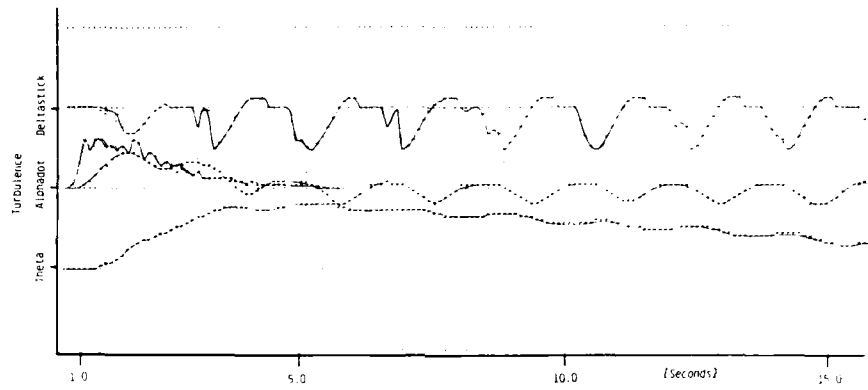

Figure 9: SAINT simulation plot: Excessive stick pumping, time to recover 20 seconds

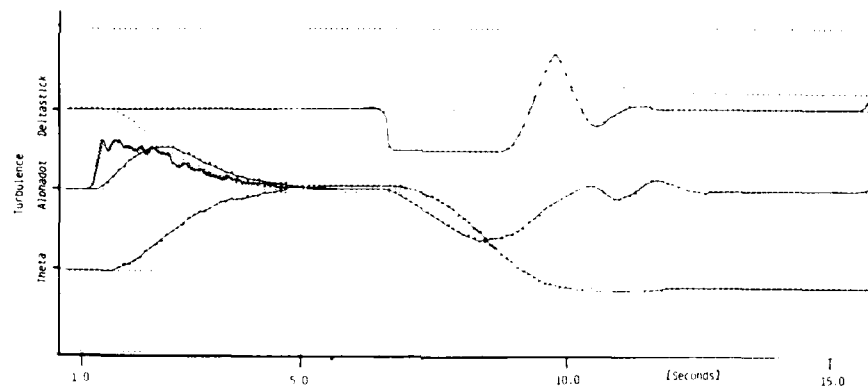

Figure 10: SAINT simulation plot: Pitch-up from starting the control action too late

TRENDS IN GROUND-BASED AND IN-FLIGHT SIMULATORS
FOR DEVELOPMENT APPLICATIONS

by

Paul E. Blatt and Don R. Gum
Control Synthesis Branch, Flight Control Division
Air Force Wright Aeronautical Laboratories
Aeronautical Systems Division, Wright-Patterson AFB, Ohio 45433

SUMMARY

This paper describes current capabilities and future trends for research and development simulators - both ground-based and in-flight. Engineering simulators are applied as design tools for synthesis and assessment of advanced aircraft, flight control systems, avionics system design, and cockpit man-machine integration (see Figure 1). The scope of the paper covers primarily real-time, piloted flight simulation for dynamic applications. No training simulation implications are intended.

INTRODUCTION

Engineering simulation has emerged as an absolutely essential, yet imperfect, design tool for the synthesis and assessment of advanced military aircraft and their critical subsystems. Simulation provides for the assessment of advanced technologies by pilots and crews under credible mission scenarios. Simulation first introduces the human element interactively into the design process. Realistic system performance requirements can be established in combat situations against various threat force structures before committing to system development.

We can think of simulation as "bridging-the-gap" between off-line computer analysis and flight testing (see Figure 2). Advanced aircraft and many of the critical subsystems follow a classical hierarchical design validation cycle consisting of analysis, simulation and flight testing (see Figure 3). Increasing fidelity and design confidence is achieved with each phase of development, but at significantly increasing cost. Elimination of major design deficiencies early in the development process results in considerable cost savings. Thus manned engineering simulation can be a powerful, cost-effective tool for design verification prior to hardware fabrication and for hardware/software validation prior to first-flight.

Certain flight-critical subsystems, such as fly-by-wire flight controls for highly unstable aircraft, must operate flawlessly on the first flight. Complete hardware, software, and control law flying qualities must operate for prescribed mission tasks, in severe weather conditions, and with various combinations of failures without introducing critical transients or pilot-induced oscillations (PIO). Failure to operate properly is often catastrophic. Failure mode-and-effects must first be explored in a perfectly safe environment. Cockpit designs must be carefully developed in context of anticipated mission scenarios to satisfy demanding pilot workloads through skillful use of automation and proper display/switchology selection. Engineering simulation is an absolutely essential design tool for these functions.

In prior aircraft developments, many of the subsystems were electro-mechanical devices. With today's emergence of integrated avionics information systems, these independent devices have been replaced by networks of computers and multiplexed buses. Thus, the total integrated design, dynamic operation, and safety are vitally dependent upon the embedded software design. The transfer of the design problem from dedicated subsystem designers to central software designers has often been fraught with technical difficulties and costly contract overruns. Integrated system software must be verified under dynamic, real-time, multi-mode conditions. Engineering simulation remains the crucial software validation milestone prior to first flight.

Categories of Engineering Simulations. Engineering simulations can be categorized into six major classes of applications (see Table I). Each class of simulation has unique sets of requirements and levels of rigor and fidelity to satisfy the objectives of the experimental validation process.

Class I Pre-first Flight of Advanced Aircraft - Represents one of the most critical applications of engineering simulation as first-flight safety is often entirely dependent upon the correct simulation modeling, its perceptual cue representation, the flight control system design synthesis, and the flying qualities task assessment. Experimental procedures must be carefully selected to identify crucial design deficiencies under nominal and off-nominal design and environmental conditions including extremes of the flight envelope. Failure modes-and-effects must be clearly established. Highly rigorous, non-linear, six degree-of-freedom equations-of-motion modeling is essential for high performance military aircraft simulation. Computational processing delays and simulation time delays/phase lags must be carefully controlled and precisely measured. Perceptual cue synchronization (motion/g-force, visual system, feel system, cockpit displays, and audio effects) is an essential ingredient for accurate experimentation. The author is a firm believer that motion is a critical cue for adequate flying qualities assessment to identify potential PIO tendencies. A considerable history of flying qualities deficiencies has evolved on high performance fighters designed on fixed-base simulators.

Class II Flight Controls/Integrated Controls Development - Basic research and advanced development of closed-loop flight controls systems and higher levels of integration with fire control, propulsion controls, terrain following/terrain avoidance (TF/TA) systems, threat avoidance systems, etc. require rigorous aircraft and control modeling, and perceptual cue fidelity. While simplified linear models can be used for the conceptual phases of basic research, severe limitations are often encountered in real-world applications where extremely high gain solutions produce flexible structure limit cycles, excessive phase lags, and undesirable flying qualities effects. Again, motion cues significantly impact the flight control design as it affects the pilot's control strategy. Task oriented flying qualities tests require reasonably high levels of visual cue realism to provide the same level of information as occurs in the

TABLE 1
CLASSES OF ENGINEERING SIMULATION & FIDELITY FACTOR REQUIREMENTS

CLASS	DESCRIPTION	PURPOSE	A/C MODEL	MOTION	TASKS
I	Pre-First Flight Evaluation of New Aircraft	<ul style="list-style-type: none"> Control Law Design Flying Qualities Stability & Control Failure Modes & Effects Exploration of Flt Envelope Test Pilot Training 	<ul style="list-style-type: none"> Non-Linear 6 Deg-of-Freedom (DOF) Highly Rigorous 	X	<ul style="list-style-type: none"> First Flight Safety Take-off & Landing Academics Tracking Tasks Validate Flight Test Plan
II	Flight Control/Integrated Controls Dev	<ul style="list-style-type: none"> Flying Qualities Gain/Phase Margins Ride Qualities Structural Mode Control Integrated Controls 	<ul style="list-style-type: none"> 6 DOF Broad-Bandwidth 	X	<ul style="list-style-type: none"> Mission Modes Tracking Tasks Academics
III	Crew Station Design (Cockpits)	<ul style="list-style-type: none"> Cockpit Development Human Factors Workload Switchology Display Formats Controllers Air Traffic Controls Mission Planning Voice Controls 	<ul style="list-style-type: none"> Linear Mod. I Detailed Cockpit 		<ul style="list-style-type: none"> Part-Task Visual/Sensor Correlation Workload Assessment Tasks
IV	Avionics Hot Bench	<ul style="list-style-type: none"> Hardware/Software V&V Iron-Bird Hydraulic & Electrical V&V Integration Signal Compatibility Redundancy Management Tests Failure Modes & Effects Sensor/Actuator Operation 	<ul style="list-style-type: none"> Linear Mod. I/II Rigorous Sensor Modeling Atmospheric Effects 		<ul style="list-style-type: none"> Mission Modes
V	Air Battle	<ul style="list-style-type: none"> Multiple A/C & Weapons Eval Maneuverability/Agility/Tactics Technology Requirement Trade-offs Threat Assessment Sensor/IFFN Effectiveness 	<ul style="list-style-type: none"> Linear Modeling Sensor Detection Logic Observability Logic Es/Countermeasures Logic Weapons Guidance 		<ul style="list-style-type: none"> Full Envelope M x n Real-Time Command & Control
VI	Total Mission	<ul style="list-style-type: none"> Man-Machine Integration Mission Management Multi-Role A/C Workload Assessment Levels of Automation Threats 	<ul style="list-style-type: none"> Medium Rigor Detailed Cockpit Weapons Guidance Es/Countermeasures 		<ul style="list-style-type: none"> Full Continuous Mission Scenarios Visual/Sensor Correlation Targets Weapons

real flying task. Good examples of this would be Formation or Aerial Refueling Tasks. For refueling, pilots utilize such features as small rows of rivets, antennas, and the relative position of the out-board engine of the tanker to determine relative motion and positioning (Ref 1). Critical visual parameters include field-of-view, scene content and texture, and resolution. High fidelity feel system mechanization and stick shaping critically impact flying quality assessments.

Class III Crew Station (Cockpit) Design - Simulators are being relied upon more and more to establish crew station designs. Cockpit design methodology derives from mission scenario functions and elements. Enabling the pilot to clearly interpret the combat situation and take corrective actions in a highly dense threat environment is a difficult man-machine design problem. Simulators can accurately recreate these mission scenarios and provide a representative workload situation for analysis and verification of the cockpit design. Peak workload conditions dictate need for automation. Simulator emphasis should be placed on cockpit rigor including display formatting and dynamics, placement, controllers, switchology, and correlation of sensor displays with out-the-window visual scenes. Trade-offs in mode controls and options can be evaluated to avoid overloading the pilot. Simulators are also used to derive fundamental psychophysical data describing human performance capabilities and limitations. Aircraft and flight control modeling can be relatively simplified for the crew station design function. Complex HUD and multi-purpose displays place heavy demands on real-time graphic generation equipment. Modern cockpit displays rely strongly on color to distinguish symbols and pictorial scenes. High resolution, real-time color graphic systems are now becoming available. Representative sensor display (EO, FLIR, radar) simulation remains a costly simulation task if done with much realism.

Class IV Avionics Hot Bench - Simulation serves as the central source for integrating avionics systems and verifying its hardware/software operation under real-time mission conditions. Emphasis is placed on signal interface compatibility, multiplex bus operation, software design and verification, and sensor functional capability. Certain advanced simulation facilities include means for directly integrating airborne sensors into the system by open portals through which the sensor can track actual ground or flight targets. Other facilities apply sophisticated anechoic chambers to provide a realistic environment for the sensor. Iron-birds are one form of a hot bench in which actual hydraulics, electrical and mechanical actuators and their power supplies are mounted on physical structure under load. Hot benches permit extensive testing of the actual hardware, redundancy management operation for a variety of failure modes, and alternate mission investigations. Simplified aircraft models and cockpits can be applied on hot benches.

Class V Air Battle - Recent trends have emphasized the use of simulation to evaluate the advantages of advanced technologies, weapons, and tactics against existing and/or projected threat forces (see Figure 4). Air battle simulation can explore requirements and perform trade-offs under realistic combat situations before committing to expensive fabrication developments. Multiple piloted simulations provide the interpretability, combat situation awareness, and adaptability in tactics not available in unmanned tactical models. Trade-offs can include aircraft performance factors, long-range target identification, comparative weapon benefits, and communication command and control effects. Variation in sensor range and resolution versus vehicle radar cross section can be addressed. Impact of electronic warfare jamming and countermeasures can be assessed. All of these evaluations are heavily influenced by the man-machine integration design of the cockpit, by the level of information to be assimilated by the pilot, and the tasks to be automated. For air battle simulations, emphasis is placed upon simplified aircraft/weapon performance dynamics, and extensive guidance sensor parameters (range, resolution, look angles, weather degradation, ground clutter effects, etc).

Class VI Total Mission - This sophisticated form of simulation is applicable to the highest level of technology integration with primary focus on inter-disciplinary man-machine aspects. Total mission simulation includes mission phases beginning with pre-mission planning, take-off, climbout, cruise, penetration (low altitude or high altitude), target acquisition, weapon delivery, threat encounters, aerial refueling, return to base, and landing in a continuous simulation. Out-the-window visual and sensor display correlation demonstrates operation throughout a wide range of adverse weather and night-time conditions. Various types of EW jamming can be applied. A full compliment of missile, bomb, and gun weapons are available. A comprehensive cockpit with a complete set of mode-selectable displays form the heart of the simulation. Total mission simulation places the greatest demands on the visual/sensor simulation equipment and data bases as well as the computer capacity. Total mission simulation is an ideal method for evaluating advanced concepts in a credible mission environment before the requirements are firm. Parametric variation of key performance factors can be carefully assessed in the experiment to understand the sensitivity of each variable. Significant cost savings can be affected by eliminating inefficient options or non-compatible combinations of technologies before hardware fabrication begins. Involvement of both test pilots and operational pilots can be most beneficial to address technical and performance issues while applying the latest tactical procedures.

While ground-based simulation capability has expanded considerably over the past ten years, limitations inherent in its equipment, modeling, and processing make it an imperfect tool. Ground-based simulation must generate its visual and motion response following the computed aircraft response and some natural lag or time delay occurs. Motion drive washout characteristics introduce considerable compromise over true motion amplitude and dynamic response. Even the best ground-based visual systems available today have fields-of-view and resolution limitations which preclude matching the resolving power of the human eye. Levels of scene detail and texture necessary to perform specific flight tasks are unknown and continue to be researched. Aerodynamic modeling errors in predicting stability derivatives from wind tunnel data can easily occur. These factors can significantly limit the effectiveness of a ground-based simulator to accurately portray actual flight and flying qualities dynamic response.

In-flight simulators are being very successfully applied to augment ground-based simulators for selected experiments to overcome some of the fundamental deficiencies inherent in ground-based simulators. In-flight simulators are modified aircraft with variable stability control systems which within certain limits permit the flying qualities of the host aircraft to match the flying qualities of the simulated aircraft.

In-flight simulators provide:

- . Perfect visual cues if the velocity and maneuver task of the simulated aircraft can be matched by the in-flight simulator host aircraft.
- . Perfect motion/force cues if the simulated aircraft response can be matched by the six degree-of-freedom response of the host aircraft.
- . The psychological advantage to the pilot that he is flying a real aircraft rather than an "electronic box."

In addition to the simulation fidelity factors, satisfactory results are strongly dependent upon another essential ingredient; proper selection of the experimental process and the pilot Briefing/Debriefing and questionnaire techniques. An overall development test plan should be established to form a continuous audit trail of consistent data from analysis, to ground-based simulation, to in-flight simulation, and throughout flight testing. This set of experimental conditions should include:

- . Flight conditions
- . Aircraft weight, cg, and configuration control
- . Environmental conditions (including turbulence and cross-winds)
- . Dynamic response to step commands, frequency response, and tracking tasks.
- . Strenuous flying qualities tasks.

Flight test results should be fed back expeditiously to the simulation facility to validate the simulator for future experimentation. A consistent set of experimental processes will greatly simplify the validation process and eliminate many flying qualities deficiencies encountered in recent aircraft developments.

Current Simulation Capabilities and Limitations

Advancements in simulation technology have continued to progress steadily over the past ten years. Predominate new features have included:

- . Mission-oriented computer imagery generation (CIG) visual systems and real-world data bases.
- . Correlated visual and sensor imagery data bases.
- . High-speed mini-computer and micro-processors for high fidelity simulations.
- . Real-time graphic processors (monochrome and color) for cockpit displays.
- . Video discs operating in near real-time
- . G-Seat force cue systems.

While most of these advancements have evolved from training simulation R&D, many of these capabilities can be directly applied to engineering simulations. A pre-requisite is an in-depth understanding of the physical limitations (e.g., time delays, bandwidth, resolution, etc) introduced by each element and a precise end-to-end calibration of the simulation to assure fidelity adequate to achieve the objectives of the specific experiment being undertaken.

Computer Technologies - A significant trend toward all-digital simulation accomplished by distributed networks of high-speed mini-computers (32 bit) and array processors has taken place in engineering facilities. Parallel processing satisfies the requirements for most real-time aircraft dynamics, propulsion, flight control, navigation, fire control, and perceptual cue solutions. Figure 5 describes the current hybrid computer network applied in the Flight Dynamics Laboratory. It will shortly be augmented with a real-time ethernet (Figure 6) to provide communications between the computers, simulation cockpits, and visual/motion systems. High fidelity aircraft dynamic solutions are computed from a set of non-linear differential equations composed of an extensive set of aerodynamic functional data points (e.g., 120,000) of from four-to-six variables. Aircraft dynamic response and closed-loop digital flight controls require solution rates of 40 hertz or faster. For example, the X-29 digital flight control system required 40 solutions per second to control this highly unstable aircraft.

Rotorcraft simulations impose some of the most stringent requirements on real-time computer solutions (Ref 2). The rotating blades are relatively flexible, and the rotor aerodynamic forces and moments depend on a radial coordinate from the hub and on blade azimuth angle. Highly non-linear effects are generated near stall conditions, at higher Mach effects, with rotor/fuselage flow interference, etc.

Hybrid computers provide capability for broad bandwidth, simulation requirements such as structural dynamics. Hybrid computers are ideal for simulating combinations of digital and analog flight controls as exist in modern fighters and for interfacing with many analog hardware devices found in simulator cockpits and with control system components.

Several industry simulation facilities are applying array processors to solve equations-of-motion within 2.5 milliseconds. Array processors can readily handle multi-functional data processing of up to four variables and also perform rapid coordinate transformation. However, software programming in machine language remains a complex, time-consuming problem.

Advanced cockpit designs are relying almost entirely on cathode ray tube (CRT) multi-purpose displays, HUDS, and Helmet Mounted displays. Color plays an important discrimination role. Both raster and stroke displays are readily available. A few real-time hybrid color cockpit displays have recently been developed, but have not yet reached a totally satisfactory application stage. Several real-time colorgraphic generation systems are now available on the market, but most require programming in machine language. Higher-order languages attuned to the cockpit display problem are urgently needed by engineering simulation facilities for rapidly responding to cockpit design changes. Video discs are another new and promising cockpit display simulation device. Video discs can store up to 54,000 frames on a 12 inch (30cm) disk and can be addressed in near real-time. Recently, writable video discs have become available so a variety of display formats could be inexpensively prepared for status displays, armament panel displays, and other slowly changing displays.

Air Battle and Total Mission simulations require tremendous computer capacity to process multiple aircraft and weapon dynamics, avionic characteristics, and command and control functions. The McDonnell Aircraft Company (MCAIR) Air Battle Simulator (Ref 3) has very dramatically demonstrated the ability to simulate up to 12 piloted aircraft simultaneously, with up to as many as 30 missiles in flight at one time, and with advanced avionics including radar, electronic warfare devices, armament controls, and comm/nav systems.

Visual Systems - Current state-of-the-art engineering visual simulation systems typically employ dome type visual displays. Some use a mosaicked approach with several projectors within the dome to provide a medium resolution and medium field-of-view presentation. Others provide low resolution background imagery that fills one-half or more of the dome. This imagery is typically provided by projectors mounted outside the dome, projecting through a hole in the dome onto the opposite side of the dome screen. Air and ground target imagery is provided by higher resolution narrow field-of-view target projectors mounted inside the dome. These projectors are either aircraft fixed, providing a higher resolution forward ground scene, or target driven providing a high resolution ground or air target image. Figure 7 is an artist concept of a typical state-of-the-art engineering simulator visual system. While some systems still utilize film transparencies for background imagery and physical scale models for target imagery, the trend is towards computer image generation (CIG) for both types of imagery.

The greatest improvement in visual simulation in recent years has been in the area of image generation. Capability to provide increased scene detail through greater edge or surface generation capacity and texture has occurred while CIG system cost has remained relatively constant. The favorable performance/cost trend is, of course, the result of advances in computer technology. Future trends indicate that with increasing use of VLSI and eventually VHSIC technology, not only will generation capability continue to increase, but cost will tend to decrease. Adequate ground detail for low-level tactical flight simulation has been questionable in the past; however, with the texturing capability being developed, this is not expected to be a problem in the future. CIG has made possible, although still very costly, the generation of full-field-of-view, high resolution imagery for fighter/attack type aircraft simulators.

The real problem is in the visual display area which has not kept pace with image generation technology. Both real and infinity optics multi-channel mosaicked display approaches have been pursued in the recent past. Since display system image input devices such as television projectors and CRT's seem to have reached a plateau in resolution performance, these approaches lead to a trade-off between resolution and the number of display channels for a given total field-of-view requirement. As the number of channels increases to provide higher resolution, the complexity, channel matching problems, and image generator costs increase rapidly. For example, assuming a 1000 by 1000 pixel per channel display, to provide a full-field-of-view tactical combat visual display with approximately three arc minutes per TV line resolution would require in excess of thirty channels. Such an approach is not practical unless major improvements are made in projector or CRT resolution.

Because of the limitations of the above brute-force approach, other more innovative and potentially lower cost approaches are under development. These approaches involve taking advantage of the psychophysics of vision and developing visual systems that employ head or head/eye coupling. All three services are pursuing the development of this type of visual system. The Air Force Aerospace Medical Research Laboratory is developing a binocular head-coupled helmet mounted display with CRT image input. The helmet display optics were developed by the Farrand Optical Company Inc under Air Force sponsorship. The imagery is currently generated by a calligraphic CIG system. This will be replaced in the near future with a two-channel raster scan CIG system. CAE of Canada, under Air Force Human Resources Laboratory (AFHRL) sponsorship, is developing a head/eye coupled display based on the same basic helmet display optics, but with fiber optics and light-valve projectors as the image input. A picture of this helmet display system is shown in Figure 8. The display for each eye has both a background and a high resolution inset channel. Its imagery is generated by a four-channel CIG system. The Naval Training Equipment Center and the Air Force Simulator System Program Office are jointly developing with the Singer Company, a head/eye coupled projector/dome visual system. The Army is developing (under an AFHRL contract with the General Electric Company) a similar head/eye coupled projector/dome visual system. While several of these visual systems are similar in overall concept, the implementations are quite different and unique.

All of these visual systems are intended to portray only the instantaneous visual scene as seen by the pilot at any particular instant rather than portraying the total outside world regardless of where the pilot is looking. The approaches are all tailored in varying degrees to match human visual system psychophysical performance. As a result, only the field-of-view and resolution required by the pilot/operator where he is looking is required at any particular instant. This translates into high resolution imagery only being required over the very small foveal field-of-view, rather than high resolution over the total aircraft field-of-view. If these visual system developments are successful, the result will be high performance visual systems with significantly fewer display and image generator channels and lower cost.

Motion/Force Cues - Little has been accomplished in the past ten years to relieve the controversy over the importance of motion cues for engineering simulations. Fundamental criteria for when to apply motion dynamic cues required to perform a specific task continues to be significantly lacking. Table II identifies the importance of motion cues for flight control design and related flying qualities experiments. However, the general trend in many US industry simulator facilities has been toward fixed-base simulators with more sophisticated visual systems. While these simulators very adequately perform cockpit design and system integration demonstrations, little evidence has been presented that these fixed-base simulators exhibit adequate fidelity for performing accurate flight control design flying qualities validation studies. In fact, there has been a steadily increasing number of PIO problems on high performance fighter designs emerging from fixed-base simulators. Lateral-axis design problems predominate. However, a contributing factor may also be a lack of stringent experimental processes to fully exercise the resulting control law design in tasks which will identify flying qualities "cliffs" in performance.

A number of engineering simulation facilities continue to use six degree-of-freedom synergistic platform motion systems. These devices appear to provide adequate motion cues for large transports or other low-g, slowly responding aircraft. However, considerable disenchantment has occurred due to false cues when applied to fighter high-g, large maneuver situations or because of undesirable coupling between axis of rotorcraft simulations.

Manual control theory describes motion acceleration as providing lead information to the pilot which significantly aids in performing tracking tasks. Motion acceleration is perceived first through the vestibular and non-vestibular proprioceptor systems and then through the visual system; an important effect when assessing flight dynamics and flying qualities. It is also obvious that a fixed-base simulator provides no high frequency body component coupling feedback which contributes to PIO with adverse combinations of aircraft dynamics. Also, it has been the author's personal observation that pilots tend to apply considerably different control strategies in fixed-base simulators than in motion-base simulators.

TABLE II
Importance of Motion Cues for Engineering Simulation

- . Flying Qualities Assessments
- . Flight Control Law Design
- . Failure Mode and Effects
- . Ride Qualities Effects
- . Direct Force Modes (CCV)
- . Rotorcraft/VSTOL Landing/Hover
- . Reduced Stability A/C Dynamic Interactions
- . Buffet and Departure

While motion-base simulation is strongly recommended for advanced aircraft and related flight control design assessment, high fidelity motion is an essential quality. Washout filter algorithms establishing the motion base drive response characteristics need to be tailored to the tasks being performed. Poor motion effects may be worse than no motion at all. Critical factors impacting motion fidelity include:

- . Excessive time delays and phase lags
- . Lack of synchronization with the visual system
- . Inadequate acceleration levels and/or amplitude of motion
- . Inadequate bandwidth
- . Inappropriate washout algorithms for the task
- . Jerkiness or abrupt reversals
- . Loud disturbing noises

Current large motion-base simulators are characterized by the Flight Dynamics Laboratory's LAMARS and Northrop's Large Amplitude Simulator (LAS), NASA Ames' Flight Simulator for Advanced Aircraft (FSAA) and Vertical Motion Simulator (VMS), and a new English simulator motion base being developed at RAE Bedford. See Figure 9 for a description of these simulators and their performance characteristics.

For applications where the effects of sustained-g total force environment is critical (e.g., man-machine capabilities at the extremes of controlled or uncontrolled flight), the US Naval Air Development Center has recently extensively modified its Dynamic Flight Simulator (DFS) to increase its performance. DFS (Ref 4) integrates (a) a three degree-of-freedom man-rated centrifuge which is pilot controllable to 15 g's with onset rates up to 10 g/sec, (b) aircraft cockpit and controls, and (c) color CIG visual system. The drive concept has been modified and is now based on psychophysical data describing human motion perception.

Other force cue devices being applied include g-seats, g-suits, seat shakers, and helmet loaders; however, effective drive concepts for these devices are just now being developed. Some of these devices were originally intended to provide sustained g-force effects with motion bases providing the higher bandwidth g-onset cues. However, recent research (Ref 5) conducted by the Air Force Aerospace Medical Research Laboratory (AFAMRL) has shown that drive algorithms have been developed which make g-seats effective on-set cuing devices. Modern g-seats (Ref 6) have the ability to change seat cushion attitude, elevation, and contour. Variable tension lap belts apply pressure to the abdominal area to provide lateral forces, negative g, and braking acceleration cues to the pilot. Hydraulic and improved pneumatic servos provide highly responsive (30 ms rise time and 10 Hz bandwidth) seat response capability.

The AFAMRL has been using a very capable g-seat designed to support research in seat motion cuing devices (ref 5). This seat is being used in a program to investigate the use of a dynamic seat-pan display for training and communicating motion information. They have developed a roll axis drive algorithm which, when used with the responsive g-seat, can provide effective on-set motion cuing. Subjects trained in this seat were able to achieve equivalent performance a disturbance tracking task to those trained in a whole body motion system performing the same task. Pilot describing functions were similar indicating that the subjects were able to utilize motion cues in both devices to generate lead in their describing functions.

Later, research (Ref 7) indicates that the training in the g-seat does not transfer to the whole body motion device and vice versa. This indicates that while motion information is utilized effectively in both devices, it is being detected through different motion sensing receptors. In the whole body motion device, the vestibular system seems to dominate, whereas in the g-seat, the non-vestibular proprioceptors (pressure and muscle/spindle) seem to dominate. The implications of these results are that the g-seat may not be effective in training simulators, but it may be quite useful in fixed-base engineering simulators for providing motion information to elicit control behavior equivalent to that in a motion environment.

In Flight Simulators - In-flight simulators bridge a critical gap between ground-based simulators and full-scale flight testing by overcoming some of the crucial visual/motion compromises still found in ground-based simulators that limit fidelity. For purposes of this paper, a distinction will be made between in-flight simulators, variable stability aircraft, and technology demonstrator test aircraft.

- . In-flight simulators are general-purpose simulators which can accurately reproduce at the pilot's station the motion time response (six degree-of-freedom characteristics) of another aircraft.

- . Variable stability aircraft can vary its own dynamic response over a wide range of dynamic stability characteristics (often in a fixed control structure), but may not be capable of accurately matching all response parameters of another aircraft.

- . Technology demonstrators are dedicated test aircraft modified with advanced technologies for extended flight test assessment.

Table III (Ref 8), is a summary of the In-flight Simulators and Variable Stability Aircraft in North America and Europe. A pertinent observation is that the majority of the in-flight simulators are no longer representative of modern fighter or V/STOL aircraft performance and require major modernization to the host aircraft and computer capabilities. Within the USAF, the NT-33A and NC-131A Total In-flight Simulator (TIFS) have been veritable work-horses simulating effectively all of the recent - past U.S. military aircraft, performing a broad range of flight research, and providing training for AF and Navy Test Pilot's Schools. In practically every case of new aircraft assessment, the in-flight simulators have identified one or more critical control deficiencies which had been overlooked in ground-based simulators. The NT-33A and TIFS also provide international support for selected programs.

Recent and near-term in-flight simulator modernization programs have included the Calspan Learjet (Test Pilot School training), Germany's Advanced Technology Testing Aircraft System (ATTAS) VFW 614 (Figure 10) scheduled for operation in 1985, and the Advanced Technology Testing Helicopter System (ATTHES) Bo 105 helicopter, and the British Hawk (Test Pilot School training). TIFS is being improved with advanced computers, avionics and cockpit (Figure 11). NASA had concluded a design study for a variable stability V/STOL aircraft to modify an AV-8B Harrier, but to-date this has become a technology demonstrator with no in-flight simulation capability.

The USAF has instituted a program to develop a modern high-performance fighter in-flight simulator to serve as a national facility to replace the NT-33A in-flight simulator. This program, titled VISTA (Ref 9) (Variable-stability In-flight Simulator Test Aircraft), will modify an F-16D with a variable stability control system and a reprogrammable cockpit (Figure 12). VISTA will include an all-attitude maneuvering, model reference control system. The simulated aircraft aerodynamics, kinematics, and flight control parameters will be individually modeled. VISTA is scheduled for operation in 1990.

Simulation Fidelity Validation - Specific criteria and guidelines are lacking as to means for validating simulations to assure that the simulation is adequate to achieve the objectives of the experiment. Considerable trade-offs on modeling rigor and perceptual cue environment must be decided. These decisions are difficult to make objectively as the choices depend on complex psychophysical and well as application issues. Decisions reached can have costly, long lead-time effects. Unfortunately, no "science of simulation" exists. A certain degree of "black art" still remains in the field of simulation. A bank of experimental data and guidelines is urgently needed.

Futuristic Trend Projections

Projections of futuristic trends in ground-based engineering simulation for the next ten years are:

- . Significantly increased dependence on Air Battle Simulation which pits advanced technology aircraft, avionics, weapons, and tactics against various threat force structures under credible mission scenarios. Air Battle Simulators will serve as a major source of trade-off studies to determine effective sets of requirements prior to initiating formal weapon system development programs.

- . Large national and industrial simulation facilities will be networked together to share critical simulation equipment and models. Real-time simulation operations will be conducted across large geographical areas to perform trade-off comparisons of various advanced technologies against current and projected threat structures.

- . VHSIC (Very High Speed Integrated Circuits) will add orders of magnitude capability to advanced computers and CIC visual systems. Current prototype VHSIC chips are achieving four-fold functional complexity over currently available commercial chips. Within the next four years, a 100-fold increase in throughput is predicted.

- . Visual Technology Advancements:

- . For selected cases, helmet mounted displays will replace complex visual displays (domes, mosaicked CRTs, etc).

- . Both head and eye tracking devices will be applied for expanded field-of-view visual systems and to insert high resolution detail into the area being viewed by the pilot.

- . Highly realistic texturing techniques will overcome current CIG scene limitations in depth and range and will make CIG totally acceptable for engineering tasks.
- . Worldwide data bases will be finalized so that any desired visual/sensor mission scenario can be readily assessed.
- . Wide spread application of the Ada software language will begin to replace FORTRAN as the primary simulation language.
- . Application of Artificial Intelligence (AI), e.g., Expert Systems, Natural Language machine interaction, Self-learning controls, etc. for high-speed decision making within combat aircraft will require blending of symbolic AI processors and LISP or PROLOG languages with more conventional digital processors in simulation facilities.
- . Substantial research and experimental validation will be conducted to develop simulation fidelity criteria correlated with flight test results. Continued research will be performed to better define and model human perception.

CONCLUSION

Engineering simulation is viewed as one of the predominate aerospace design tools of the future. Industry and government organizations are investing heavily in modernization of their computer and visual simulation equipments. Simulators will be applied extensively to establish weapon system requirements under major air battle conditions against various threat force structures, tactics and technologies.

REFERENCES

1. Sitterley, T.; C-5A/C-141B Aerial Refueling Simulator Training Effectiveness - Conclusions from Practical Experience, Paper for Interservice/Industry Training Equipment Conference, Orlando, Florida, November/December 1981.
2. AGARD-AR-209: Report of the Working Group on Large-Scale Computing in Aeronautics
3. Passmore, H. and Green, J.; A Glimpse Into the Future of Air Combat, McDonnell Douglas Aircraft Co.
4. Crosbie, R.J., and Eyth, J.; A total G-Force Environment Dynamic Flight Simulator, Paper for AIAA Aerospace Science Conference, Reno, Nevada, January 1983.
5. McMillan, G.R., Levison, W.H., and Morton, E.A.; Motion Simulation with a G-Seat System: Sensory and Performance Mechanisms, Paper for Ninth Psychology in DoD Symposium, USAF Academy; 1984.
6. Albery, W.G., Gum, D.R., and Kron, G.J.; Motion and Force Cueing Requirements and Techniques for Advanced Tactical Aircraft Simulation, AGARD-CP-249; October 1978.
7. Morton, E.A.; An Investigation Regarding the Use of a Dynamic Seat-Pan Display for Training and as a Device for Communicating Roll-Axis Motion Information, Proceedings of the Third Symposium on Aviation Psychology, April 1985.
8. Burhman, J.; Future Requirements for Airborne Simulation AGARD-AR-188, April 1984.
9. Barry, J., and Schelhorn, A.E.; In-flight Simulators - Powerful Tools for Flight Research and Development. Paper for NAECON 85, Dayton, Ohio, May 1985.

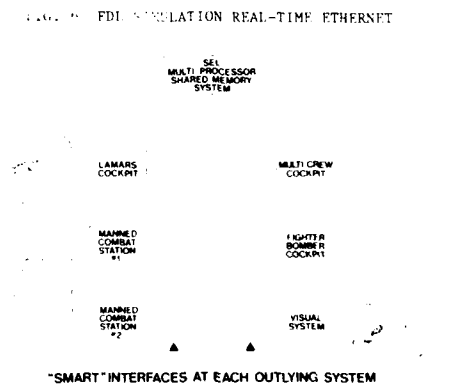
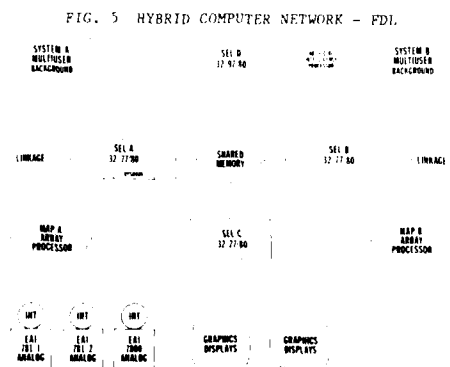
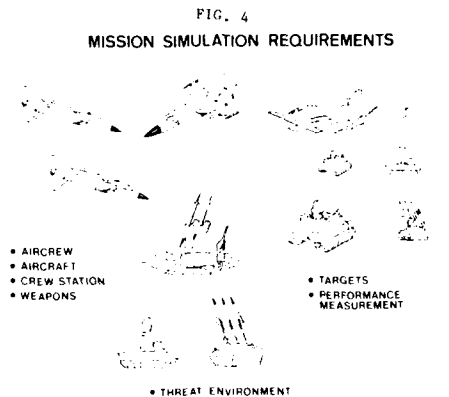
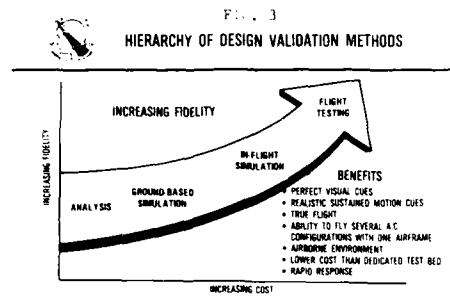
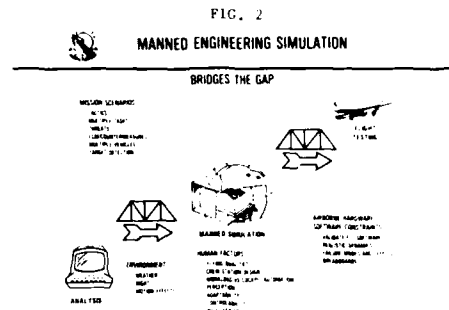
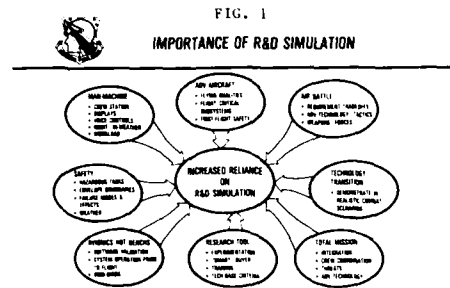

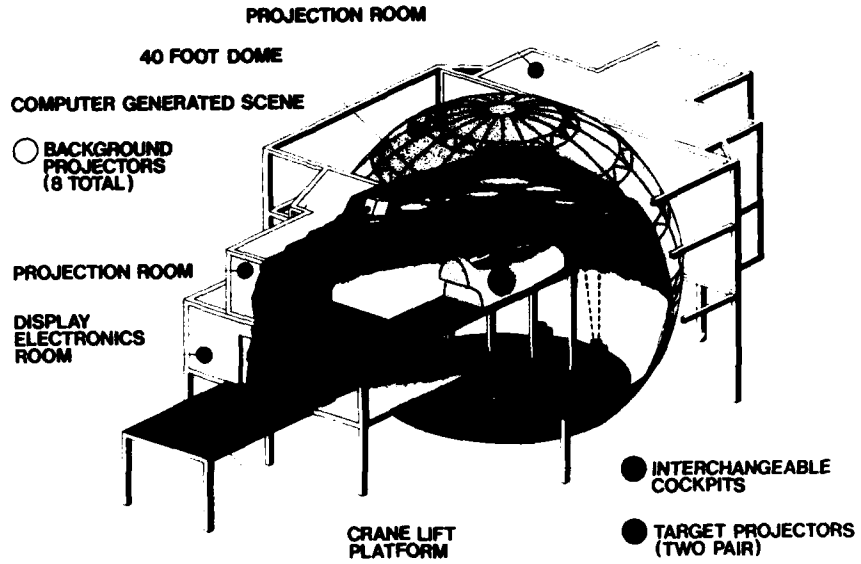

STEED Visual System

FIG. 7

FIG. 8 FIBER-OPTIC HELMET MOUNTED DISPLAY (PHOTO COURTESY OF CAE ELECTRONICS LTD)

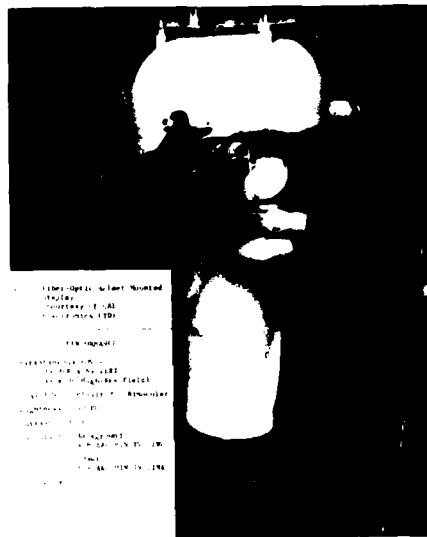

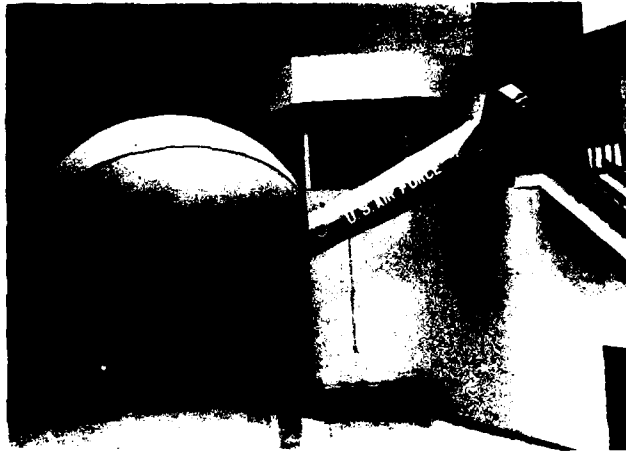

FDL LARGE AMPLITUDE, MULTIMODE, AEROSPACE RESEARCH SIMULATOR (LAMARS)

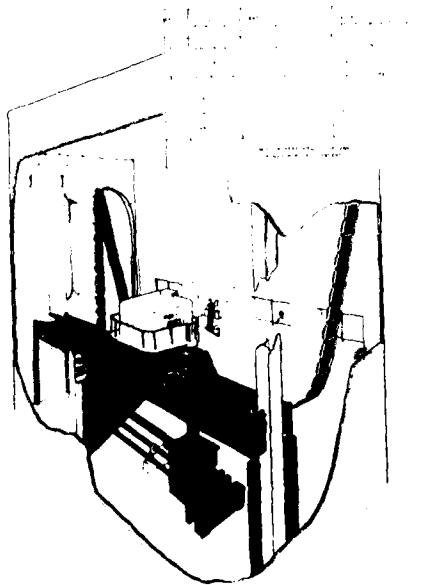

NASA AMES VERTICAL MOTION SIMULATOR

FIG. 9 LARGE MOTION-BASE SIMULATORS

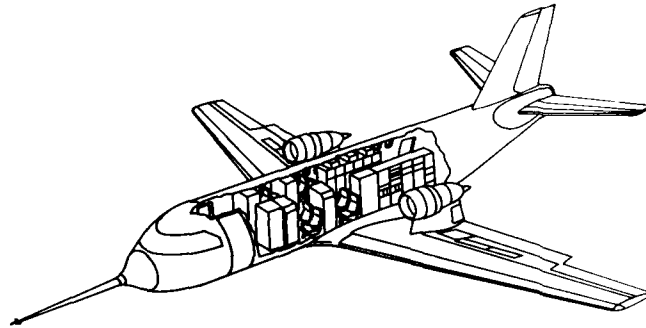

FIG. 10 GERMAN ADVANCED TECHNOLOGIES TESTING AIRCRAFT SYSTEMS (ATTAS)



FIG. 11 TIFS MODERNIZATION

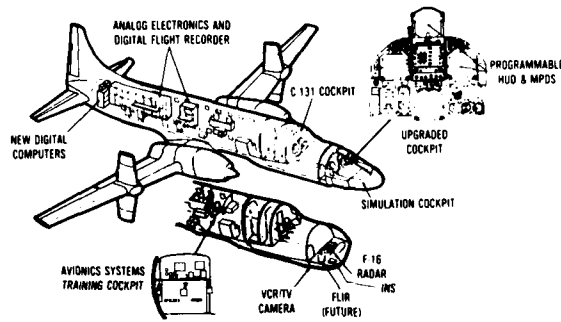
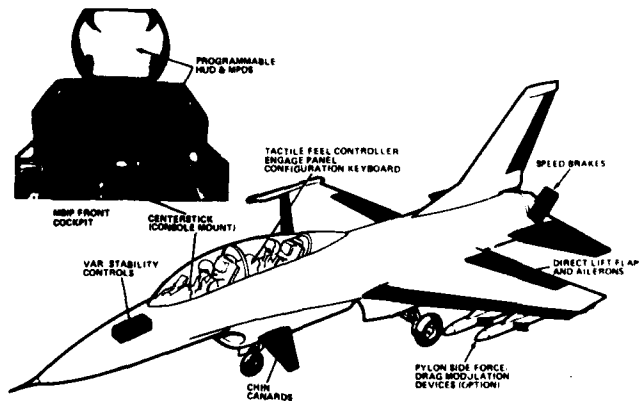

FIG. 12 VISTA F-16D CANDIDATE CONFIGURATION



PILOTED SIMULATION IN THE DEVELOPMENT
OF THE XV-15 TILT ROTOR RESEARCH AIRCRAFT

by

Roger L. Marr
Bell Helicopter Textron
P. O. Box 482
Fort Worth, Texas 76101
U.S.A.

and

Gary B. Churchill
U.S. Army Aeromechanics Lab
Moffett Field, California
U.S.A.

SUMMARY

The effective use of simulation in the XV-15 preliminary design was demonstrated in that all primary program objectives were met. The initial simulation evaluation during the source evaluation board proceedings contributed significantly to performance and stability and control evaluations. Subsequent simulation periods provided major contributions in the areas of control concepts, cockpit configuration, handling qualities, pilot workload, failure effects and recovery procedures. The fidelity of the simulation also provided a valuable pilot training aid as well as a means of evaluating the tilt rotor concept for various military and civil missions. Simulation continues to provide valuable design data for refinement of automatic flight control systems and design support for future tilt rotor applications. Throughout, fidelity has been a prime issue and has resulted in unique data and methods to validate and update the tilt rotor math model. Researchers' participation from contractor and government agencies in the development of this simulation effort has led to a generic tilt rotor simulation capability on numerous facilities.

INTRODUCTION

The XV-15 Tilt Rotor Research Aircraft program is a joint Army/NASA/Navy program initiated in 1973 as a "proof-of-concept" and "technology demonstrator" program (Navy participation started in 1979). Two aircraft were built by Bell Helicopter Textron, and basic proof-of-concept flight testing was completed in September 1981. At present, one aircraft is at Ames Research Center in continuation of government flight testing for aircraft documentation, and the other aircraft is at Bell Helicopter Textron for further contractor tilt rotor development and for participation in military applications demonstrations. Significant program milestones are shown in Figure 1.

The tilt rotor is a relatively complex concept and, based on the history of other V/STOL aircraft developmental programs, was initially considered to also be a high risk program. Therefore, from program conception, comprehensive piloted simulation evaluation was made an integral part of the design, development, and test programs. Starting with parallel simulation of the bidders' design proposals, and continuing through the proof-of-concept flight testing (October 1981), simulation was integral with the entire test program. Before the first hover tests of the XV-15 (May 1977), four high-fidelity simulations and one limited hover simulation were conducted at NASA Ames Research Center. The high-fidelity simulations utilized the Flight Simulator for Advanced Aircraft (FSAA), whereas the limited hover simulation was performed on the Six-Degree-of-Freedom (6-DOF) simulator. After initiation of the contractor's flight test program (April 1979), five additional simulations were accomplished to investigate flight test anomalies for systems refinement and for military missions evaluations. Three of these utilized the FSAA, and two utilized the Vertical Motion Simulator (VMS). These simulation periods were also used to aid in pilot training and familiarization in addition to satisfying the research objectives.

Since the piloted simulation efforts were considered to be a critical element of the program, the overall fidelity of the simulation was of prime importance. This paper presents the manner in which the XV-15 simulations were developed to provide the required fidelity, its use throughout the program, its limitations, and an assessment of its value relative to flight test, program performance, and safety.

Aircraft Description

A brief description of the XV-15 tilt rotor is in order to help in defining the scope and complexities of the simulation modeling. The tilt rotor aircraft hovers and operates in low-speed flight as a helicopter, with similar control requirements (Figure 2). It also flies as a high performance turboprop airplane using conventional aircraft control surfaces (Figure 3). In between modes, it uses a combination of rotor and conventional airplane controls. Control phasing is accomplished mechanically with control system gains scheduled with nacelle tilt and airspeed.

The XV-15 is powered by two Lycoming T-53 turboshaft engines, designated LTC1K-4K, which are rated at 1,550 shp for takeoff with a normal rating of 1,250 shp. A transmission cross-shaft interconnects both rotors to permit the rotors to be driven by one engine for "engine out" operation. The engines, transmissions, and rotor systems are located in wing tip nacelles which can be rotated 95 degrees (from 0 degrees in airplane mode to 5 degrees aft of vertical in helicopter mode). The rotors are 25 feet in diameter, three-bladed, with a blade twist of 41 degrees from root to tip. The rotors are gimbal-mounted to the hub with an elastomeric spring for additional control augmentation. The wing span is 32 feet from spinner to spinner, and the aircraft is 42 feet long (Figure 4). At the design gross weight of 13,000 lb, the wing loading is 77 lb/ft² and the disc loading is 13.2 lb/ft². The XV-15 carries 1,475 pounds of fuel, which allows a research flight of about 1 hour. It is equipped with LW-3B rocket ejection seats for the crew of two.

In the helicopter mode, the XV-15 flight control system can be compared to that of a lateral displaced "tandem" rotor helicopter. The use of rotor collective pitch, cyclic pitch, differential cyclic, and differential collective for aircraft control are shown in Figure 5. During helicopter flight, the airplane type control surfaces are active but are ineffective at low speeds. Rotor controls are mechanically phased out as conversion progresses to the airplane mode as the elevator, flaperons (full span flaps with outboard ailerons), and rudders become effective. Full span, electrically operated flaps are used during hover to reduce download and in forward flight to reduce stall speed for an increased conversion corridor envelope. A schematic of the flight control system is presented in Figure 6.

Rotor rpm is maintained by a blade-pitch governor which detects an error between commanded and actual rpm. In helicopter mode, collective pitch inputs from the governor are additive with the collective pitch inputs by the pilot from the power lever and lateral stick. Total authority for collective pitch is transferred to the governor during conversion to airplane mode. A manual collective pitch control wheel, located on the center console, may be used by the pilot for rpm control should the dual-channel governor fail.

Stability and control augmentation (SCAS) is provided by a three-axis rate system with a pitch or roll attitude retention feature. SCAS gains are varied with conversion angle to provide the appropriate rate damping and control augmentation for either helicopter or airplane mode flight. Pitch and roll axes have dual channels, whereas the yaw axis is single channel. SCAS-OFF flight has been routinely demonstrated; damping and control are degraded, but the XV-15 is quite safe to fly, even though the pilot workload is significantly higher. A Force Feel System (FFS) provides stick and pedal forces proportional to control displacements in addition to isolating the pilot controls from SCAS feedback forces. Force gradients are increased and trim rates are decreased with increasing airspeed. With FFS-OFF, secondary pitch trim is available at a reduced rate; control forces are high but manageable.

An interconnected, hydraulically powered conversion system provides 95 degrees of nacelle tilt at a rate of approximately 7.5 deg/sec. A continuous conversion can be accomplished in about 12 seconds, or the pilot can position the nacelles at any angle. Hydraulic power for conversion is triply redundant. In the event of a total electrical failure, the pilot still has mechanical access to hydraulic power to convert to the helicopter mode.

Additional details of the XV-15 design are given in References 1 through 4.

Simulation Description

The simulation facilities at Ames Research Center (ARC) are designed to provide research simulation capability for a wide variety of aircraft concepts, ranging from helicopters and V/STOL aircraft to supersonic transports or the Space Shuttle. These facilities are operated and maintained by the Flight Systems and Simulation Research Division of the Aeronautics and Flight Systems Directorate. The active time required for any one simulation on a facility (FSAA or VMS) varies from several weeks to several months.

The elements common in a flight simulation are the cab and motion system, the visual system, control loaders, and a host computer. Within the host computer at ARC, standard software is provided for all equations of motion, transformations, motion and visual drives, etc. The user provides the mathematical model for the aircraft, including all aerodynamics, structural dynamics (if required), flight controls, instrument requirements, and definitions of force feel system parameters. When developed in this manner, a change from one test configuration to another only requires changing the simulator cab instrument panel and controls to the configuration to that required by the user. Installation and checkout of the user's mathematical model and integration of the desired elements into an operating system, including generating fidelity data as required by the user, normally is accomplished in about 2 weeks. Fidelity data checks normally include such items as static and dynamic checks; control loader, visual, and motion systems frequency response checks; or any other special checks specified by the user. Results of some of the significant checks used to assess the XV-15 simulation fidelity will be discussed later.

Development

The decision to make piloted simulation a significant and integral part of the Tilt Rotor Research Aircraft (TRAA) program was made in July 1971, before TRRA program approval by NASA and Army Headquarters. The requests for proposals for the mathematical model and simulation development were released in August 1971, with the following ground rules for the bidders:

- 1) A complete real-time nonlinear mathematical model and aircraft simulation was to be developed.
- 2) Modular mathematical model construction in a specified format was to be used.
- 3) The mathematical model was to be programmed and checked out at the contractor's facility simultaneously with programming and checkout at the government's facility.
- 4) The simulation was to be operational on the FSAA in one year.

Two bidders, Boeing-Vertol (BVC) and Bell Helicopter Textron (BHT), responded to the request for proposals and were also the only subsequent bidders for the aircraft development.

Although this program was extremely ambitious, both contractors completed their efforts in about 14 months, which was in time to effectively use the simulation during the Source Evaluation Board (SEB) proceedings in March 1973. Both the contractors and the government obtained significant benefits from the simulation development program. The contractors developed an "in-house" simulation for their use in proposal preparation, and the government received a program from each contractor. These programs provided both the contractor's data and analytical methods to the government for evaluation of the contractor's performance and stability and control proposal submittals.

Mathematical Model

A detailed discussion of the XV-15 mathematical model (Reference 5) is beyond the scope of this paper. At the time it was developed, it was the largest, most complex model ever implemented on the simulation facilities at Ames Research Center. It contains a complete nonlinear representation of the XV-15 airframe (includes an aerodynamic representation through an angle of attack and sideslip range of ± 180 degrees), interactions of the rotor wake on the airframe, all flight controls, automatic FCS, and the landing gear characteristics (both aerodynamics and dynamics). The rotor model uses linearized aerodynamics with nonuniform inflow rather than strip analysis, since the later requires more computer capacity and computation time than available for real time simulation. The rotor model is valid for the full XV-15 envelope, including autorotations. Additional information concerning the details of modeling the nonlinear aerodynamic rotor wake interactions are available in Reference 6. The total math model represents 13 degrees of freedom. Since program inception, the mathematical model has undergone eight revisions to maintain its status relative to the aircraft configuration and data base. The latest revision was completed in 1980 and represents the present aircraft configuration.

The requirement for a modular structure of the mathematical model was specified to streamline the general programming and to provide simple access to any particular module for changes resulting from variations in the design or from improvements in the data bases. Thus, although each module had a fixed input and output, the modeling within the module could be simplistic initially and increased in complexity as analysis or data justified. The final configuration of the mathematical model contains 20 separate subsystems or modules.

During the early phases of the XV-15 program, Systems Technology, Inc. (STI), Hawthorn, California, provided technical support to the Project Office in the areas of flight controls development and simulation. As a result of these efforts, STI developed an addendum to the BHT mathematical model which provided the additional capability to evaluate the effects of control system hysteresis and flexibility on aircraft characteristics (Reference 7). This modeling could be switched in or out for evaluations, and was quite valuable in identifying limit cycle behavior.

A significant portion of the simulation use was devoted to identifying failure effects and recovery procedures, since significant adverse failure effects could require control system redesign. System failures for single or dual engine, hydraulic system, electrical system, SCAS, PFS, and governor were modeled. These failures were controlled by the test engineer and were helpful during training and familiarization of new pilots.

The effects of airframe aeroelastics were considered during the contractor development phase. The modes evaluated were the wing vertical bending (3.5 Hz), wing torsion (10 Hz), and wing chord bending (6 Hz). These were evaluated on the contractor's simulation facility, where it was determined that the only mode affecting the pilot control task was wing vertical bending. This occurred only in hovering flight and the net effect was to cause an approximate 0.1 second lag in vertical

response to control. Since this lag is approximately the same as that induced by the digital simulation cycle time lag, further considerations of aeroelasticity were deleted.

Simulation Hardware

During the course of the XV-15 program, three of the simulators at Ames Research Center were used: the Flight Simulator for Advanced Aircraft (FSAA), the Vertical Motion Simulator (VMS), and the Six-Degree-of-Freedom Motion Simulator (6-DOF). The FSAA and VMS mathematical models were essentially identical, the differences were in the motion and visual systems. The 6-DOF simulation utilized a simplified perturbation type mathematical model applicable only to hover and low speed flight (0 to 10 knots).

Flight Simulator for Advanced Aircraft. The FSAA (Figure 7) has been the workhorse of the XV-15 simulation program. It permitted large amplitude motion and rapid accelerations for the many tasks and evaluations performed. The cab is provided with a virtual image televised visually which displays scenes from one of two large terrain boards. These boards provided a typical airport and runway environment, a STOL port, carrier or other ship models for landing, a map-of-the-earth terrain area for low level flight around vegetation and hills, and other features to enhance the realism of the simulation. Provisions for instrument flight to minimums were available, as well as flight "on top" to escape the confines of the terrain board boundaries. Other aids to the pilot include a Visual Approach Slope Indicator (VASI) light for approaches to the runway. A XDS Sigma 8 digital computer was used to compute the aircraft dynamics. Electro-hydraulic control loaders were used to provide the variable stick and pedal control forces necessary for the simulation. The right side of the two place cab was set up for the XV-15 with essential controls and instruments. Details of the cockpit will be discussed later.

Vertical Motion Simulator. The VMS (Figure 8) became operational in 1980 for VTOL simulation evaluations and was used for the XV-15 to examine SCAS and rpm governor modifications for improved response and handling qualities. The VMS differs from the FSAA in that it has large vertical motion, computer generated imagery (CGI) with multiple data bases, and a four-window visual display for improved visual cues. The cockpit layout, control loaders, and host computer used are essentially the same as those used during the FSAA simulations.

Six-Degree-of-Freedom Motion Simulator. The 6-DOF (Figure 9) simulator has a single place cab and is well suited for the evaluation of VTOL aircraft in hovering flight. Helicopter controls were used for this limited evaluation, and the cockpit was left open to provide a one-to-one visual simulation, using the interior of the facility and the view outside through the open hanger doors. The motion system was driven directly from computed aircraft accelerations (no washouts were employed). Therefore, within a 18-foot cube, all attitude, motion, and visual cues were real to the pilot. This simulation was initiated to investigate height control response characteristics with more realistic cues than could be provided on the FSAA or the VMS. An early look at some failure modes was also accomplished during this simulation and an automatic system to increase engine power in the event of a single engine failure during hover was eliminated from the design. In all cases, the pilot's response was faster than an automatic system with power application.

Simulated Cockpit. The cockpit setup for the XV-15 simulations provided the pilots with the essential controls and instruments to effectively simulate the aircraft. The instrument panel of the simulator is shown in Figure 10 compared to that of the actual XV-15 aircraft as shown in Figure 11. The cockpit configuration was identical for both the FSAA and VMS simulations. The instruments, although not identical to those in the aircraft in most cases, were similar and their locations in the simulator closely matched their locations in the XV-15. Most of the engine, transmission, systems gages, and the caution panel were not functional but only mocked-up in the simulator cab. The center console of the simulator cab incorporated the SCAS, FFS, governor panels, and manual rpm wheel which were identical in function and appearance to the actual aircraft.

The power lever and control stick in the simulator cab were configured to match those in the XV-15, and also incorporated the same functions and switches. Also on the center console, the landing gear and flap switches were located in their proper location and appearance. All of this attention to detail was considered important to properly simulate the overall pilot-aircraft interaction in the development of this research simulation. This was not only true for the evaluations of the aircraft response and handling qualities, but also for the transfer of operational training the pilots would acquire during the simulations before the first flight of the aircraft. Instrument scan, control feel and manipulation, and systems operation during normal operation and failure modes had to be realistic.

SIMULATION EVALUATIONS

Chronology

The XV-15 simulation chronology is shown in Figure 12. The initial XV-15 simulation on the FSAA in 1973 was a comparative evaluation of the two contractors' design proposals for a tilt rotor aircraft. NASA, Army, and contractor pilots and engineers participated in the evaluation. The results from this evaluation were included as "other factors" in the Source Evaluation Board process. After the

selection of the contractor to build the two tilt rotor research aircraft in July 1973, a limited simulation was conducted on the 6-DOF simulator for some early design decisions related to the Thrust Power Management System (TPMS). This was followed in December 1973 by an extensive evaluation on the FSAA of the selected BHT tilt rotor configuration (Reference 8). That simulation covered control system and subsystem engineering studies, aircraft handling qualities investigations, and the initial cockpit layout evaluation.

Significant control system and mathematical model refinements resulted from that evaluation. It was followed by another major simulation in July 1976 to continue design analysis of the control system and subsystems in both normal and failure modes and to investigate the associated handling qualities (Reference 9). Cockpit layout evaluations continued and changes were subsequently incorporated in the aircraft. In October 1975, the simulation objectives were to investigate various operational conditions and to look at envelope boundaries or flight limit conditions (Reference 10). Cockpit changes made as the result of the previous simulation were also evaluated. Flight boundary conditions evaluated included thrust limits, blade loading limits, and wing stall characteristics. This evaluation completed the initial program related simulated activity prior to the rollout and first hover flights of the XV-15. Prior to the initial flight test period, the mathematical model continued to be used for advanced tilt rotor applications. Investigations into the control, guidance, and display concepts (Reference 11) were accomplished as well as evaluations into military applications and missions capabilities with advanced control configurations.

After the initial hover tests, and before forward flight testing, the XV-15 was tested extensively in the Ames 40- by 80- Foot Wind Tunnel in 1978. These tests were preceded by offline simulation of aircraft failures considered to be critical during the wind tunnel testing. This was done to identify any potentially dangerous conditions that might occur during the tunnel testing and to develop recovery procedures as required. Simulations continued at Ames Research Center after the start of the contractor flight test program in April 1979. The first of these evaluations, conducted in early 1980, had pilot familiarization as a primary objective along with limited evaluation for military applications. The next test period, in the fall of 1980, was devoted primarily to control system modification evaluations. This test was conducted on the newly activated Vertical Motion Simulator at Ames while one of the XV-15 aircraft was also being tested at the Dryden Flight Research Center, Edwards AFB, California. SCAS and governor modifications were evaluated and later tested in the aircraft. The following simulation, conducted early in 1981, also involved SCAS and governor refinements. Another simulation was run on the FSAA in the fall of 1981 while both the XV-15 aircraft were on flight status at Ames. In addition to evaluating future modifications and configurations, this test was for simulation validation. The last simulation, on the VMS in May 1983, was for the purpose of evaluating upgrading of the XV-15 mathematical model to a Generic Tilt Rotor (GTR) simulation model to allow simulation of all types of tilt rotor aircraft. This evaluation was the initial familiarization for the V-22 tilt rotor program.

Nonpiloted use of the simulation has been in the development of a parameter identification algorithm for use in stability and control flight testing (Reference 12). The aircraft stability derivatives and response time histories for the various flight conditions can be processed to obtain the derivatives via this parameter identification algorithm. The procedure can be used during the flight test program to validate and update the math model.

Simulation Fidelity

Simulation fidelity necessarily remains a subjective assessment from the pilot's viewpoint, although specific recommendations for means of assessment in terms of objective measurements are beginning to be made available (References 13-16). Regardless of assessment technique, any specific determination of fidelity is tempered by the purpose of the simulation and the tasks to be accomplished. Good fidelity is assured if the simulation-generated cues cause the simulator task to specifically relate to the real world task or if that which the pilot experiences and learns in the simulator adequately prepares him for the actual aircraft experience. Sinacori (13) defines fidelity in two ways: engineering fidelity, meaning the measured closeness to the real world; and perceptual fidelity, meaning the perceived closeness to the real world. Good perceptual fidelity is obtained when the pilot gets out of the simulator saying, "That is the airplane". If the simulation engineering staff can fully corroborate or rationalize the basis for the pilot either making or not making this statement, then both fidelity categories are defined.

Verification

Simulator Hardware Effects. The components of simulator hardware affecting simulation fidelity are the flight controls, the motion and associated washout systems, and the visual systems. These systems critically affect the fidelity in all phases of operation, occasionally in subtle, unanticipated ways. At the onset of the simulation program, it was determined that specific, definitive criteria and methods of evaluating simulation fidelity, as affected by these systems, were lacking. Systems Technology, Inc. was, therefore, asked to provide these under the ongoing support services contract during the XV-15 program (References 17 and 18). The procedures developed by STI defined the performance data requirements and criteria for initial evaluation, as well as suggested periodic checks to be made against possible degradation through usage.

With the exception of the static alignment procedure for the visual system setup, all fidelity check procedures have been automated to facilitate their use in the event such use is warranted by suspected malfunction.

Visual System. The capability to perform fidelity checks quickly and easily is of particular importance for the visual systems (this was found to be the case more for the FSAA which uses a terrain board visual than the VMS which uses a CGI visual). The static alignment procedure is performed during set-up at the beginning of each day of testing. This is normally sufficient, but if the simulated aircraft requires a low pilot eye height relative to the runway, the alignment must be repeated several times during the day. The linear calibrations and the dynamic response of the system using the SAFE (Six Axis Frequency Evaluation) procedure are normally not variant, and the weekly checks during maintenance periods were found sufficient. SAFE is a program originally designed to measure the frequency response of the motion base. It was also adapted to use on the visual systems and McFadden loader systems.

The performance checks were made using the full up simulation by performing relatively severe low altitude, low speed maneuvers, which included lateral and longitudinal quick stops, jump takeoffs, and landings. Time history plots of the visual system errors gave an immediate presentation of any system problem, such as degraded servo performance, of hysteresis and threshold problems.

Motion System. In general, the motion system performance checks on both the FSAA and VMS were consistent. The daily motion checks adequately verified overall performance, and the weekly SAFE runs provided complete software and computer equipment verifications. The only significant deficiency was the lack of a capability of evaluating the motion drive and washout logic systems and making direct comparisons with calculated aircraft responses. As with most simulator motion systems, the determination of washout characteristics is somewhat left up to the evaluator, and adequate cab instrumentation has not been available for specific determination of cab to aircraft response transfer function. The motion drive logic parameters were set up by a "simulation" pilot operating the system before it is given to evaluation pilots. This occasionally required iteration until an overall acceptable motion response is achieved. This, in the case on the XV-15, also required different gains for different modes of flight in going from helicopter to airplane response characteristics.

Control Loaders. McFadden electrohydraulic control loaders were provided for the control sticks and pedals, and found to be quite reliable in all simulations. The data for force versus displacement and frequency responses were spot checked periodically and did not change throughout the test.

Simulator Limitations

The most significant problem encountered during the simulation evaluations was height control in hover. Initially on the FSAA, the problem was severe and caused vertical pilot-induced oscillation (PIO). This complicated the vertical landing tasks and, at times, the simulated aircraft could not be successfully landed. Part of the problem was identified as visual system time constant errors and motion system washouts. Although improvements were made, the problem was not completely eliminated. Vertical response could be improved by reducing the engine time constant and providing some lead in the power lever input. Pilot ratings during hovering tasks in the VMS simulator with improved visual cues were generally Level 2 whereas ratings for the aircraft are Level 1. The reduction in rating was primarily due to a combination of lack of realistic visual cues, insufficient texture and cycle time delay. Motion cues, although beneficial, did not influence ratings significantly.

Airspeed limits were initially imposed on the simulator operations because of numerical instabilities resulting from computer cycle time delay. Generally, the simulator airspeed limit occurred at 220 KCAS and was manifested by the start of a low magnitude, moderate frequency pitch oscillation. This could be avoided by operating the pitch SCAS OFF. In fixed base operation, it could not be seen by the pilot, but it was still occurring. These limits remained until cycle times were decreased through the use of high speed computers on the VMS. This problem was not observed on the aircraft. To date, the XV-15 has achieved 225 KIAS (235 KCAS) in level flight and 250 KIAS (262 KCAS) in a dive.

As with any window monitor televised display, the field of view (FOV) available to the pilot is limited. For the FSAA, a single monitor was used which has a FOV of 47 degrees laterally and 37 degrees vertically. The FOV from the pilot's seat (right side of the cockpit) of the aircraft is shown in Figure 13 as compared to that of the simulator. The limitations are obvious. In an attempt to improve the FOV over the nose, the viewpoint was biased four degrees down. Some pilots perceived this as a slight nose down attitude and corrected for it with a small aft stick input. This resulted in inadvertent aft translation in hover.

The visual cues were significantly improved in the VMS which uses a four window CGI visual system with a FOV of 120 degrees laterally and 40 degrees vertically, also shown in Figure 13. The only limitation indicated by the evaluation pilots have been limited overhead FOV during acceleration and in maneuvering turns to the left.

Simulations of shipboard operation on the FSAA were limited due to the lack of peripheral cues. A straight in approach to the deck from the stern could be made; however, 45 degree sliding approaches were not possible. Once the deck filled the FOV attitude control was very difficult, especially with the addition of deck motion for various sea states. Shipboard operation, however, has already been demonstrated successfully on the VMS and with the XV-15 aircraft during sea trials aboard the US Tripoli, June 1984.

The FSAA visual system terrain board provided a flyable length of 13.2 km (8.2 statute miles) and a width of 2.7 km (1.7 statute miles). When pilots exceed these limits, a simulated cloud bank is encountered simulating IFR conditions and instrument flight. This occasionally caused orientation problems, particularly during high speed operation. For extended cruise flight or evaluations without terrain board limitations, the camera was placed in a "tub" to provide a 360 degree scene above the clouds, with distant clouds and sky for attitude reference. The lack of visual translation cues in this environment was not significant to the pilot. This was not a problem on the VMS for the CGI system since several data base visual displays are available with large flyable areas.

Validation

Flight Test Correlation. The final test of both engineering and perceptual fidelity come with comparison of simulation and flight test results.

Performance. Level flight predicted and measured performance data are presented in Figure 14. The only change in the simulation program to generate the calculated data was to increase the basic flat plate drag for interference effects as obtained during full scale wind tunnel tests on the XV-15 (NASA-Ames 40 by 80 foot wind tunnel in 1978).

Static Trim. The static longitudinal trim data are presented in Figure 15 and 16 with control position and pitch attitude as a function of airspeed and nacelle incidence angle. Correlation is generally good.

Dynamics. The real essence of simulation fidelity is in obtaining good correlation on system dynamics: pilot responses, disturbance responses, and stability characteristics. Handling quality characteristics have in general been in good agreement. Only minor modeling changes have been made to provide correlation. These were primarily in making control rigging changes to reflect the aircraft's final flight test configuration. An example of a longitudinal control step input in helicopter and airplane mode is shown in Figure 17.

Accomplishments

During the XV-15 simulation period (approximately 12 years), all of the primary program objectives were met. After the development of the detailed mathematical model, a valuable research tool was made available to the design engineers and pilots involved in the aircraft development. Before flight of the aircraft, detailed design studies and analyses on the simulator resulted in major improvements to the XV-15 configuration and control system. Piloted evaluations permitted the optimization of control system gains, the early investigation of failure modes, and development of cockpit procedures. Proposed design changes were evaluated and either incorporated in the XV-15 design, modified, or discarded based on simulation results. The many hours of piloted operation of the simulator provided valuable training before flying this unconventional aircraft. The intermediate, or conversion mode characteristics were also investigated thoroughly. A major accomplishment of this extensive simulation activity was that there were no significant surprises to the pilots in flight, and that they were comfortable with the aircraft throughout the flight development. The similarities of the simulation to actual flight, commented upon from the beginning, enhanced safety during the flight test program. Following the first flight, pilot comment was that "The aircraft characteristics were very similar to those flown on the simulator, only the visual was better!" In most cases, simulation limitation made the simulator harder to fly than the aircraft.

As the test program progressed, the simulation model was updated to reflect flight test data. Control system refinements were evaluated on the simulator before they were incorporated into the design. These refinements, primarily to the rpm governor and SCAS, improved the response and handling qualities of the aircraft. Flight test anomalies, real or calculated, were investigated, and in many cases resolved through the use of the simulator. In addition to the simulation activities directly related to flight test and configuration development, limited investigations were made of potential of the XV-15 for military applications.

Simulations were initially used to establish control law criteria for the Automatic Flight Control System (SCAS, FFS, and Thrust/Power Management System), cockpit control functions (normal and failed operation), and to support the cockpit layout design. Several cockpit instruments peculiar to the XV-15 were developed through these simulations. These included a dual dial airspeed indicator covering very low airspeeds as well as high speed, a triple torque meter and tachometer, a conversion corridor indicator. The control panel switching and failure enunciation for the AFCS panels and method of operating the thrust/power lever were also developed through simulation evaluations. The control system and instrument configurations developed

during the initial simulation of these systems are still being flown in the XV-15. One of the most significant benefits attributed to the use of the simulation in the preliminary design of the XV-15 was that no flight test time was required to develop handling qualities or AFCS systems. This allowed efficient use of flight time to conduct operational evaluations for the tilt rotor concept.

During the XV-15 developmental flight testing, the simulator model was continually updated through correlation with flight test results. It was also converted into a generic tilt rotor model (GTR) to allow evaluations for any type of future tilt rotor aircraft such as JVX or LHX. The JVX preliminary design simulation program, accomplished on the VMS, was also structured after the XV-15 simulation program. Testing was recently completed in June 1985.

The math model has and is being used to evaluate new AFCS systems for tilt rotor application such as an improved AFCS, flapping controller, lateral translation (lateral swashplate control), automatic scheduling of flaps and rpm, improved rpm governing, and side arm controls.

The tilt rotor math model is currently in wide use. In addition to being on the NASA-Ames FSAA, VMS, and 6-DOF facilities, the GTR version has been made available to other government agencies (to be operational at Patuxent River Naval Test Center early next year) and is being used extensively at both Bell-Boeing simulator facilities. Both contractor and government personnel continue to be active in the development of the simulation effort.

Conclusions

The XV-15 Tilt Rotor simulation evaluations accomplished the specific design objectives as originally set forth in providing design evaluation, pilot training, and reduced flight testing for systems and handling qualities development. The simulation provided the confidence to the pilots and engineers in the design and handling qualities of the aircraft during the flight program. The XV-15 continues to safely demonstrate tilt rotor technology for military and civil applications. Simulation evaluation for tilt rotor aircraft are continuing in the preliminary design and full scale development of the V-22 Osprey.

The following are derived from the XV-15 Tilt Rotor Research Aircraft simulation evaluations:

- 1) Simulation has been a powerful tool in procurement, design, development, and flight test.
- 2) A requirement for simulation during proposal evaluations provides major benefits to the procuring agency.
- 3) Perceptual fidelity evaluations of simulation are invalid without engineering corroborations.
- 4) Engineering fidelity evaluations require full equipment dynamic response evaluations, as well as evaluations of the mathematical model.
- 5) Use of simulation for developing specification or certification criteria is invalid without substantiating simulation fidelity.
- 6) Fidelity evaluation procedures and criteria are the most significant deficiencies in simulation testing.

REFERENCES

1. Maisel, Martin D., et al., "NASA/Army XV-15 Tilt Rotor Research Aircraft Familiarization Document." NASA TM X-62-407, 1975.
2. Marr, R. L., Willis, J. M., and Churchill, G. B., "Flight Control System Development for the XV-15 Tilt Rotor Aircraft," presented at the 32nd Annual National Forum of the American Helicopter Society, Washington, D.C., May 1976.
3. Dugan, D. C., Erhart, R. G., and Schroers, L. G., "The XV-15 Tilt Rotor Research Aircraft," NASA TM-81244 (AVRADCOM Technical Report 80-A-15), 1980.
4. "XV-15 Flight Manual," TP-78-XV-15-1, Bell Helicopter Textron, Aug. 15, 1980.
5. Sinacori, John B., Stapleford, Robert L., Jewell, Wayne F., and Lehman, John M., "Researchers Guide to the Nasa Ames Flight Simulator for Advanced Aircraft (FSAA)," NASA CR-2875, 1975.
6. Harenda, P. B., Joglekar, M. J., Gaffey, T. M., and Marr, R. L., "A Mathematical Model for Real Time Flight Simulation of the XV-15 Tilt Rotor Research Aircraft," NASA CR-114614 (release pending final report approval), 1982.
7. Marr, Roger L., and Roderick, W.E.B., "Handling Qualities Evaluation of the XV-15 Tilt Rotor Research Aircraft," presented at the 30th Annual National Forum of the American Helicopter Society, Washington D.C., May 1974.

8. Ringland, Robert F., and Craig, Samuel J., "Simulated Limit Cycle Behavior in the Collective Control Linkage of the XV-15 Aircraft," Working Paper 1048-11, Systems Technology, Inc., Hawthorne, California, November 1975.
9. Marr, R. L., "XV-15 Flight Simulator Period No. 1, FSAA Simulator, December 1973", prepared under Contract No. NAS2-7800 by Bell Helicopter Textron, February 13, 1974.
10. Marr, R. L., "XV-15 Flight Simulator Period No. 2, FSAA Simulator, July 1974," prepared under Contract No. NAS2-7800 by Bell Helicopter Textron, February 13, 1974.
11. Marr, R. L., "XV-15 Flight Simulator Period No. 3, FSAA Simulator, September 1975," prepared under Contract No. NAS2-7800 by Bell Helicopter Textron, January 13, 1976.
12. Brigadier, William L., "Analysis of Control Actuator Authority Requirements for Attitude and Translational Rate Command Augmentation Systems for the XV-15 Tilt Rotor Research Aircraft," NASA TM-81,243, 1980 (AVRADCOM Technical Report TR-80-A-13, December 1980).
13. Hall, W. E., "Preliminary Flight Test Planning for XV-15 Tilt Rotor Aircraft," NASA CR-152392, 1979.
14. Sinacori, John B., "Piloted Aircraft Simulation Concepts and Overview," Technical Report 1074-2, Systems Technology, Inc., Hawthorne, California, prepared under NASA Contract NAS2-9024, March 1978.
15. "Fidelity of Simulation for Pilot Training," edited by David L. Key, AGARD Advisory Report No. 159, October 1980.
16. NASA Ad Hoc Advisory Subcommittee, Avionics, Control and Human Factors, 1980.
17. Heffley, Robert K., Clement, Warren F., et al., "Determination of Motion and Visual System Requirements for Flight Training Simulators, Technical Report No. 1162-1, Systems Technology, Inc., Hawthorne, California, August 1981 (forthcoming Army Research Institute report).
18. Craig, S. J., "Data Requirements for Simulation Fidelity Assurance," Working Paper No. 1048-1, Systems Technology, Inc., Hawthorne, California, prepared under NASA Contract No. NAS2-8025, June 1974.

• Contract Signed	July 1973
• No. 1 XV-15 Rollout	October 1976
• Ground Tie-Down Testing	January-May 1977
• Hover Test (Aircraft No. 1)	May 1977
• Wind Tunnel Tests (Aircraft No. 1)	May-June 1978
• Contractor Flight Tests (No. 2)	Apr 1979-July 1980
• Government Acceptance (No. 2)	October 1980
• Government Flight Test	Jan 1981-Continuing
• Paris Air Show (No. 1)	June 1981
• Contractor Development (No. 1)	Oct 1981-Continuing
• Military Demo (No. 1)	Mar 1981-Continuing

Fig. 1 XV-15 Aircraft Program Chronology

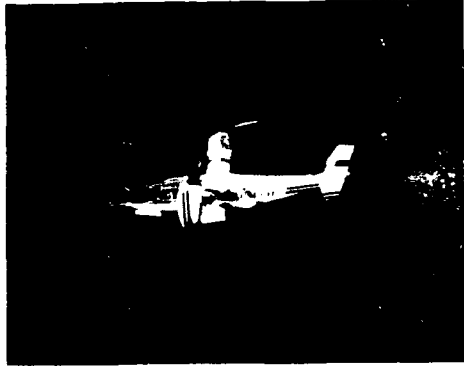

Fig. 2 XV-15 in Helicopter Mode



Fig. 3 XV-15 in Airplane Mode

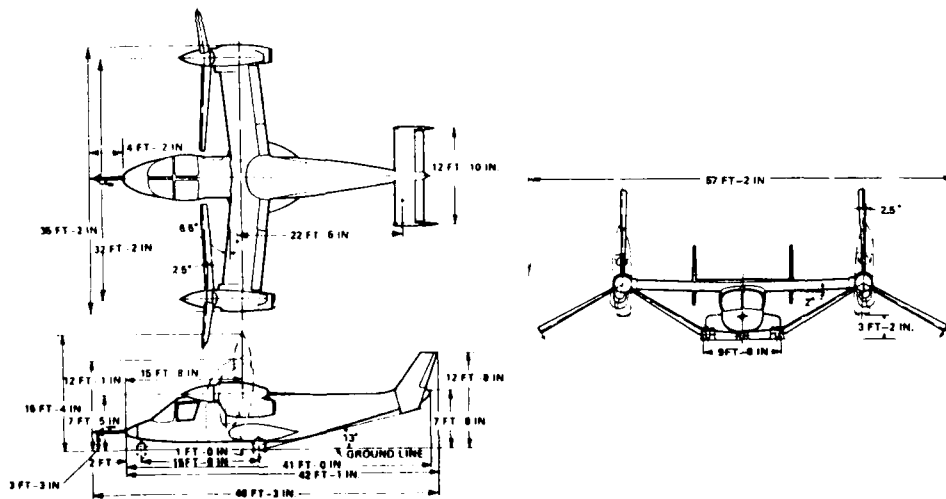

Fig. 4 XV-15 Dimensions

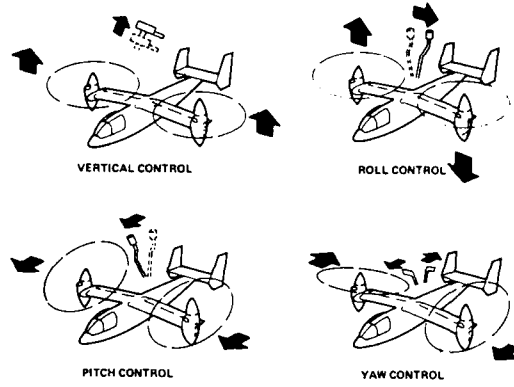

Fig. 5 Helicopter Mode Control Functions

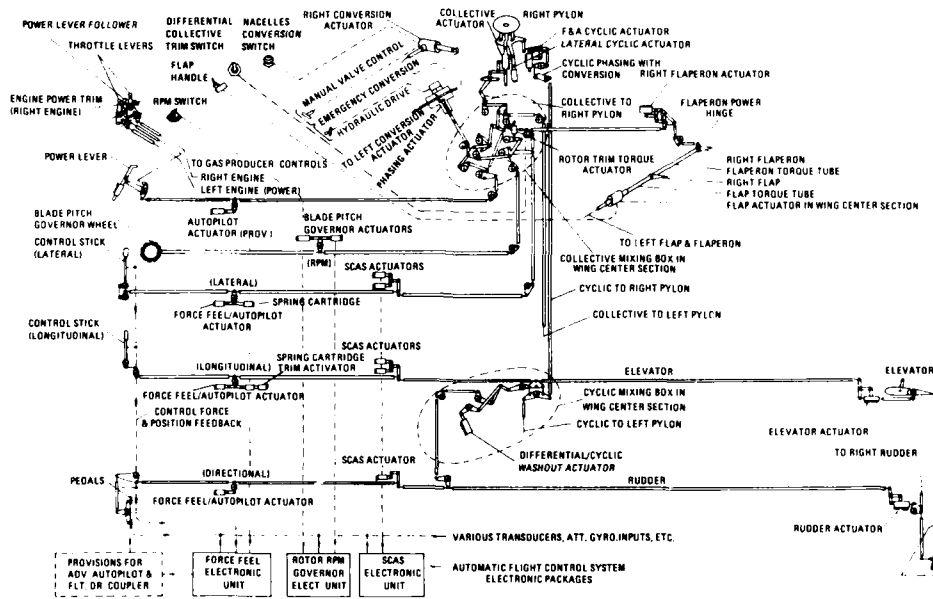

Fig. 6 Flight Control System Schematic

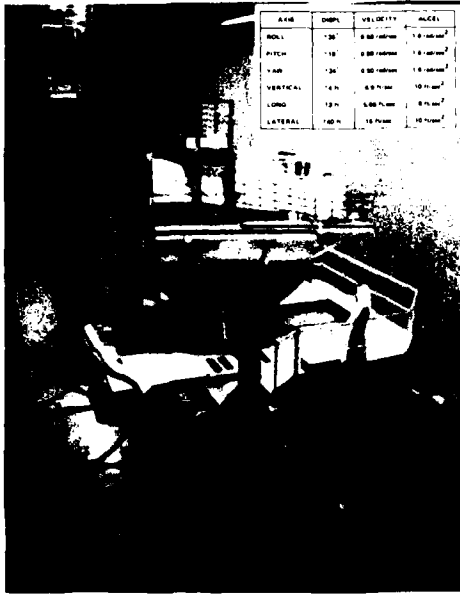

Fig. 7 Flight Simulator for Advanced Aircraft

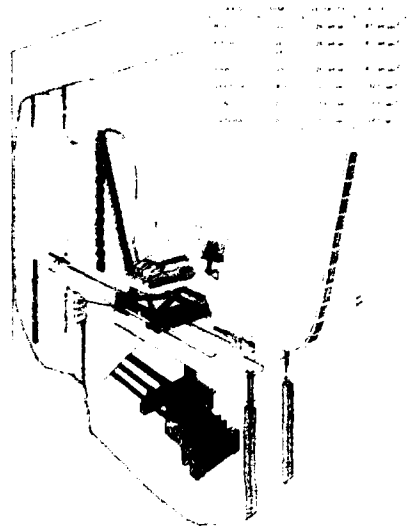

Fig. 8 Vertical Motion Simulator



Fig. 9 Six-Degree-of-Freedom Motion Simulator

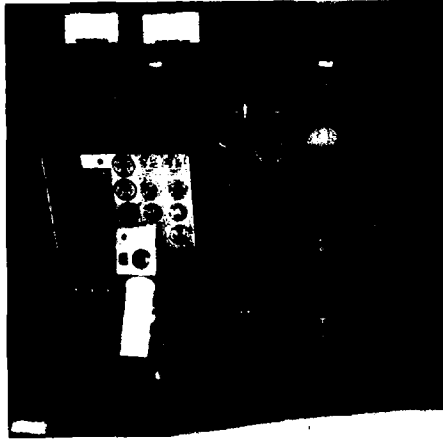

Fig. 10 XV-15 Simulator Instrument Panel



Fig. 11 XV-15 Aircraft Instrument Panel

• Simulation of Contractor Proposals	March 1973
• Limited Design Evaluation	October 1973
• Simulation of Selected Configuration	December 1973
• Control System and Handling Qualities	July 1974
• Operational and Boundary Conditions	October 1975
• Military Missions and Pilots Familiarization	March 1980
• SCAS and Governor Modifications	October 1980
• SCAS and Governor Modifications	March 1981
• Untested Modifications and Configurations	October 1981
• GTR Familiarization	May 1983

Figure 12. Aircraft Simulation Chronology

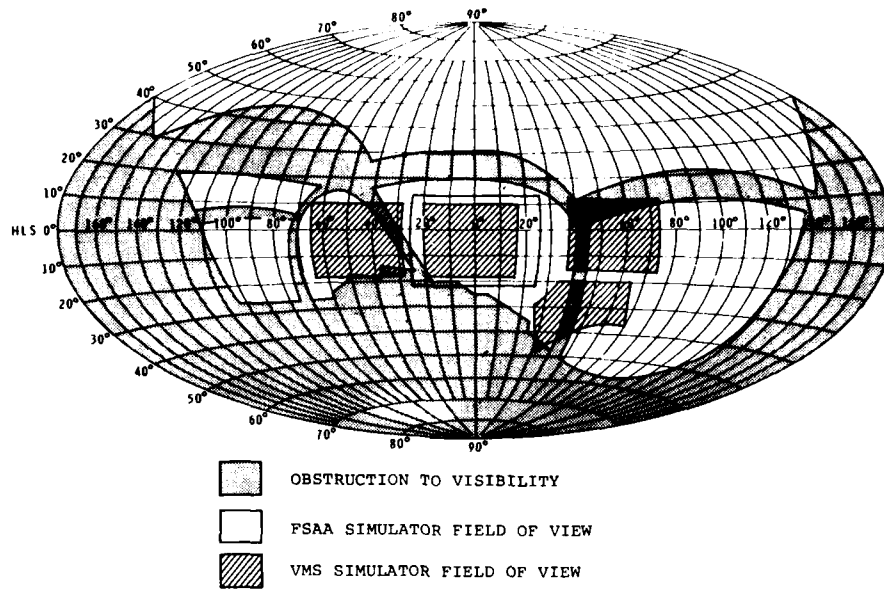

Fig. 13 XV-15 Pilot Seat Field of View

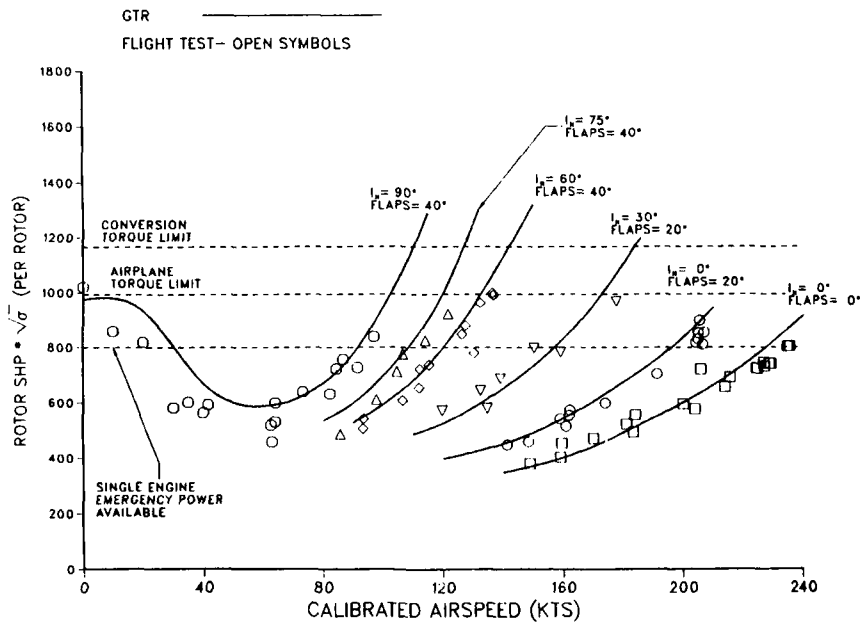

Fig. 14 XV-15 Level-Flight Performance

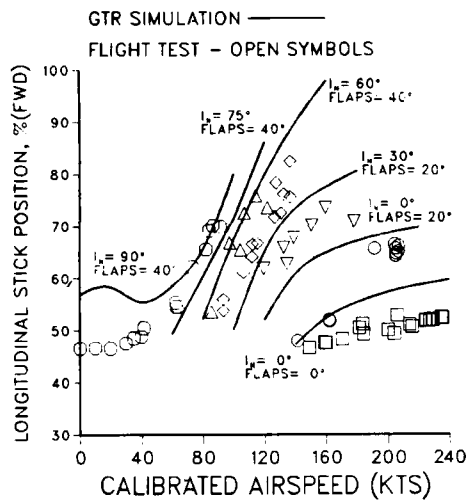

Fig. 15 XV-15/GTR Longitudinal Control

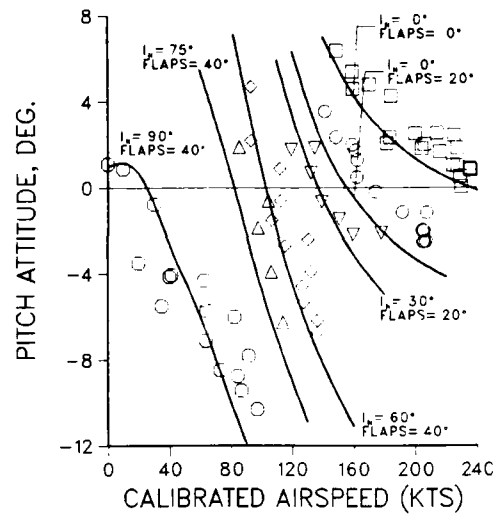

Fig. 16 XV-15/GTR Pitch Attitude

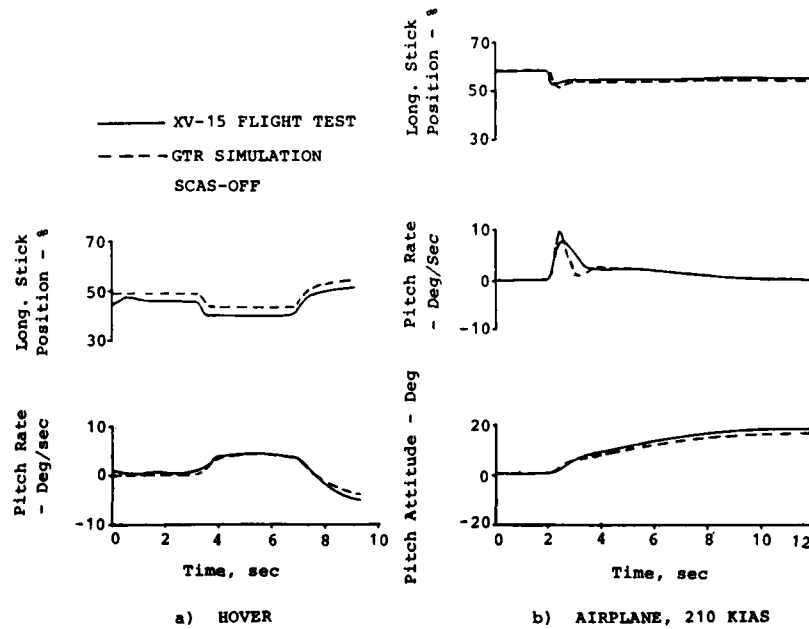

Fig. 17 Time History Correlation of XV-15/GTR Pitch Response

**SIMULATION DES COMMANDES DE VOL ELECTRIQUES
AU CENTRE D'ESSAIS EN VOL FRANÇAIS (CEV)
POUR LES AVIONS DE TRANSPORT CIVIL**

par

Mrs R. Vadrot
Centre d'Essais en Vol
Base d'Essais d'Istres
13800 Istres
France

1 - INTRODUCTION -

La mission principale du CENTRE D'ESSAIS EN VOL (C.E.V.) est d'effectuer les essais en vol officiels des aéronefs, des équipements aéronautiques et des armements aéroportés pour le compte du Ministère de la Défense ou du Ministère des Transports.

Le Centre d'Essais en vol comprend :

- une base d'essais principale à BRETIGNY/ORGE,
- deux bases d'essais à ISTRES et à CAZAUX,
- deux détachements à TOULOUSE et BORDEAUX.

Depuis son origine, en 1956, la Base d'Essais d'ISTRES a pour principale spécialité les essais d'avions et de moteurs.

La longueur de la piste réalisée sur la plaine quasi désertique de la CRAU et le climat privilégié de la région font d'ISTRES un site exceptionnellement favorable pour ces essais. Sont également implantés à ISTRES l'Ecole du Personnel Navigant d'Essais et de Réception (EPNER) et le Centre de Simulation de façon à bénéficier de la présence des pilotes et des ingénieurs d'essais des prototypes.

2 - LE CENTRE DE SIMULATION (ISTRES) -

2.1. Présentation générale du Centre de Simulation.

Le Centre de Simulation regroupe les moyens en matériel et en personnel nécessaires pour mettre en oeuvre des simulateurs de vol consacrés à l'étude et au développement des nouveaux aéronefs. L'ensemble des moyens du Centre permet de travailler au profit des avions d'armes, des hélicoptères et des avions de transport. Le Centre, qui est à la disposition des Services Officiels et des Constructeurs, a subi de considérables développements depuis 1975 en raison des intérêts nombreux que présente la simulation d'études en aéronautique :

- possibilité de travailler et de faire des choix importants avant les premiers vols d'un prototype,
- économie d'un grand nombre de vols coûteux,
- optimisation de systèmes complexes,
- élimination des risques de manoeuvres dangereuses.

L'évolution actuelle de l'aviation, avec l'introduction notamment de l'informatique embarquée, a même rendu nécessaire de tels simulateurs.

Les études actuellement effectuées aux simulateurs du CEV sont de deux types :

- les études générales amont préparent l'avenir et peuvent s'accompagner de retombées pour les grands programmes. Il s'agit par exemple d'études de qualité de vol, de figurations synthétiques, de nouveaux dispositifs de commande ou de nouvelles formules d'aéronefs,
- les aides au développement d'un nouvel appareil sont effectuées dans le cadre d'un grand programme civil ou militaire. Il s'agit principalement de l'étude des qualités de vol, de l'interface équipage-système et de la validation des spécifications des logiciels embarqués.

Pour réaliser les différents essais qui lui sont demandés, le Centre dispose de moyens importants regroupant les moyens d'environnement (cabines, mouvements, visualisations) et des moyens de calcul.

2.2. Moyens de calcul du Centre de Simulation.

Le Centre de Simulation à ISTRES est équipé de calculateurs GOULD : actuellement trois SEL 32-77/80 et deux SEL 32-87/80 sont en service.

Quatre de ces calculateurs sont capables de simulation temps réel, le dernier étant utilisé pour le développement, et permettent ainsi de mener en parallèle et simultanément quatre études temps réel.

Pour les visualisations sur tête basse ou tête haute, le tracé de figurations et de symboles est assuré par quatre systèmes SINTRA CONCEPT 60, chacun étant associé à l'un des SEL.

2.3. Moyens d'environnement mis en oeuvre pour les études civiles.

La cabine de simulation utilisée pour les études civiles est la pointe avant du prototype n°01 de l'avion MERCURE.

- Dans cette cabine équipée en fonction des études, on doit distinguer la planche de bord gauche de la planche de bord droite.

Côté Gauche : planche de bord conventionnelle avec "boule" et plateau de route.

Côté Droit : planche de bord à tubes soit côte à côte, soit l'un sous l'autre selon l'étude.

Pour les commandes, en plus des manches classiques, se trouve également implanté à gauche un manche latéral pour les études de commandes de vol électriques.

- Cette cabine peut être utilisée comme un simulateur fixe ou avec mouvement cabine à 3 ou 6 degrés de liberté selon l'étude (Fig.1).
- La visualisation du monde extérieur se fait par l'intermédiaire d'un système de génération d'image synthétique de nuit REDIFON "NOVOVIEW 2000".
- Sont également simulés les alarmes sonores et les bruits aérodynamiques, moteurs.. en fonction du domaine de vol.
- Pour les essais qui sont décrits plus loin, le modèle avion simulé est un AIRBUS A 300-F

3 - COOPERATION AEROSPATIALE - CEV ISTRES -

La coopération entre l'AEROSPATIALE et le Centre de Simulation du CEV à ISTRES a été définie début 1980 et démarra effectivement fin 1980.

Elle se justifie pour deux raisons :

- profiter de l'expérience des deux équipes dans le domaine des figurations de pilotage,
- profiter de la complémentarité des moyens mis en oeuvre :

- . outil de simulation pour étude complète du poste, y compris des systèmes, à l'AEROSPATIALE (AS.)
- . outil de simulation permettant l'étude des qualités de vol et de la pilotabilité au CEV.

Cette coopération est axée autour de deux grands thèmes d'étude.

Le premier intéresse plus particulièrement les figurations associées aux modes de pilotage alors que le second est tourné vers le développement de commandes de vols électriques (C.D.V.E.) pour avions civils avec les aspects réglementation associés et l'étude de nouveaux moyens de commande.

Dans ce papier, sera développé le second thème, à savoir :

COMMANDES PILOTE ET LOIS DE PILOTAGE EN C.D.V.E.

4 - ETUDE DES LOIS DE PILOTAGE C D V E : Première Phase. -

Cette première campagne d'essai d'Avril à Octobre 1982 au simulateur avait pour but de définir les lois de pilotage CDVE en latéral et longitudinal et d'ajuster les gains avant la campagne d'essais en vol sur AIRBUS A 300 n°3 (Banc d'essais volant) qui eut lieu au 2ème semestre 1983.

L'architecture des lois de pilotage CDVE fut définie dans le cadre des études EPOPEE, dont les essais à ISTRES s'achevèrent en Octobre 82. Pour préparer les vols de l'avion n°3, la simulation EPOPEE fut modifiée et mise au standard avion avant présentation aux pilotes pour évaluation jusqu'en fin 1983.

4.1. Lois de pilotage.

4.1.1. Loi de pilotage en profondeur.

La loi de pilotage en profondeur (Fig.2) est du type C^{*}, c'est-à-dire commande directe à court terme de la trajectoire par modulation du facteur de charge n_z .

A basses vitesses, un terme de vitesse de tangage est ajouté au retour n_z pour corriger les agitations d'assiette dues à une commande en n_z pur.

L'avion est en permanence auto-trimé. Cette fonction auto-trim est supprimée en dessous de 200 ft pour restituer l'impression d'arrondi à l'atterrissage.

La loi C^{*} comporte également plusieurs fonctions pour la sécurité, ce qui est entièrement nouveau dans le pilotage d'un avion de transport.

- limitation du facteur de charge maximal demandé,
- une stabilité nulle est assurée dans tout le domaine de vol normal par cette loi MAIS :

- . une PROTECTION EN SURVITESSE (Fig.3) permet une forte stabilité au-delà de VMO/MMO en introduisant un ordre de facteur de charge à cabrer, proportionnel à l'écart $V_c - VMO$ et limité à 1,5 g. La fonction auto-trim est alors inactive.

- . une PROTECTION EN INCIDENCE INSURPASSABLE (Fig.4) introduit une stabilité dissuasive empêchant toute excursion en-dessous de la vitesse de décrochage. Un ordre de facteur de charge à piquer proportionnel à l'écart $\Delta\alpha$ s'ajoute à l'ordre pilote, tandis que le gain de l'ordre pilote est progressivement diminué de telle façon qu'à l'incidence maximale, le facteur de charge maximum réalisable soit de 1 g. La valeur de l'incidence maximale est fonction de la configuration et du taux de décélération. La fonction auto-trim devient inactive dès l'entrée en protection.

Un avantage caractéristique d'une telle protection est son utilité à contrer un fort gradient de vent : la fonction α floor de l'auto-manette dont sont déjà équipés tous les AIRBUS assure automatiquement dans un tel cas la pleine poussée; maintenant manche à cabrer (pleine autorité), la portance maximale sera disponible.

4.1.2. Loi de pilotage en gauchissement.

La loi de pilotage correspond à une demande de vitesse de roulis (ou plus exactement $\dot{\theta}$). L'ordre élaboré est homogène à un braquage volant. Pour une inclinaison latérale supérieure à 33 degrés, un terme de stabilité spirale vient se retrancher à l'ordre pilote. (Fig.)

4.2. Essais effectués.

La mise au point des commandes de vol électriques se déroule au simulateur d'ISTRES avec manche classique et à TOULOUSE avec manche latéral.

4.2.1. Méthode de travail.

La période de mise au point a débuté en Avril 1982 pour se terminer en Octobre 1982. Durant cette période, la méthode de travail adoptée a été la suivante :

- début de semaine : mise au point des modifications, demandées par le constructeur (AS), à apporter aux lois de commande de vol au simulateur d'ISTRES par le CEV.

- Jeu-di : séance de simulation avec les Ingénieurs AEROSPATIALE.

Cette séance sert à :

- la validation des modifications apportées au logiciel,
- la mise au point de la séance pilotée du lendemain,
- des séances d'enregistrement de paramètres.

- Vendredi : séance de simulation pilotée avec des pilotes CEV ou AEROSPATIALE, suivie d'un débriefing.

Une séance pilotée dure en moyenne 3 heures, avec la participation de 2 pilotes. Se trouvent également dans la cabine du simulateur, l'ingénieur d'essai CEV, ainsi que les ingénieurs et observateurs AEROSPATIALE.

4.2.2. Remarques sur les essais.

A l'occasion de cette tranche d'essai, quelques remarques ont été faites sur les moyens mis en oeuvre pour la simulation.

Pour cet essai, l'aménagement de la planche de bord, bien que non complet, a été suffisant ; le but de cet essai étant d'évaluer le comportement de l'avion et non celui du pilote.

Par contre, pour des essais concernant une évaluation de charge de travail, il faudrait disposer d'un équipement plus complet.

Sur ce point, la remarque générale des pilotes est que, si le simulateur d'étude peut ne pas comporter tout l'équipement d'une cabine d'avion de transport, les instruments des planches de bord ainsi que les boîtiers de commandes doivent être des instruments avionnés, ou au moins en avoir l'aspect extérieur.

Pendant la première partie de cet essai, les séances pilotées se sont effectuées sans présentation d'images du monde extérieur et sans mouvement cabine, le système NOVOVIEW 2000 étant alors en cours de recette et le couplage temps réel avec mouvement cabine non encore effectué. Cette partie concernait la mise au point des lois pour les phases de vol en palier, de mise en virage, de changement de pente. L'absence de ces moyens n'a pas gêné les pilotes et ne semble pas avoir affecté les conclusions finales. Mais l'utilisation de ces moyens aurait peut-être fait découvrir plus tôt des problèmes comme celui de l'agitation importante de l'assiette longitudinale dans les premières versions des lois de commande de vol.

A partir du mois de septembre 82, l'étude des commandes de vol s'est faite dans les phases d'approche, d'arrondi et de décollage. Pour ces phases, le système de génération d'images synthétiques de nuit du monde extérieur NOVOVIEW 2000 a été utilisé. Il a permis d'effectuer des atterrissages à vue, ainsi que des décollages dans des conditions satisfaisantes.

Deux remarques principales ont été faites pour cette partie de l'essai :

- le système NOVOVIEW 2000 qui ne présente qu'une image frontale ne permet pas de restituer l'impression de hauteur par rapport au sol. Il faudrait pour cela disposer d'images latérales qui devraient permettre de restituer l'impression de vitesse verticale lors des phases d'arrondi (assiette longitudinale importante).
- l'absence de mouvement cabine ne permet pas de sentir le toucher des roues pendant l'atterrissage, ni le délestage au cours du décollage, et le roulement est trop paisible.

Ces remarques constructives ont été prises en compte par le CEV et des améliorations seront apportées dans la poursuite de ces études.

4.3. Principaux résultats de cette première phase CDVE (32 - 83).

La mise au point et l'évaluation des lois CDVE au simulateur d'ISTRES se déroulèrent d'Avril à Octobre 1982.

L'évaluation a demandé 30 heures de simulation pilotée réparties en 11 séances avec la participation des pilotes AEROSPATIALE et CEV.

L'architecture des lois CDVE mises au point au simulateur à ISTRES fut retenue pour les essais du banc volant A 300 n°3 à TOULOUSE.

En 1983, les lois de commande furent adaptées aux simulateurs d'ISTRES et de TOULOUSE pour simuler cet avion. En effet, pour cet avion, la simulation des CDVE ne pouvait se faire qu'au travers du Pilote Automatique n°1, et, de ce fait, des dissymétries étaient introduites et les gains durent être réajustés.

Que ce soit au simulateur ou sur l'avion, cette expérimentation de CDVE fut extrêmement positive et la synthèse des commentaires des pilotes ayant participé à ces essais montre :

- une approbation générale de la loi de pilotage en longitudinal,
- un enthousiasme pour les protections du domaine de vol, surtout à basse vitesse,
- une diminution évidente de la charge de travail du pilote.

Toutefois, la loi de commande en roulis n'a pas eu la qualité espérée et des études complémentaires sont nécessaires.

En résumé :

90 % de la loi de pilotage en longitudinal, définie au simulateur, a été retenue après les essais en vol A 300 n°3 pour le programme A 320,

la loi de pilotage en roulis doit être redéfinie, et l'AEROSPATIALE est demandeur d'essais à ce sujet au simulateur du CEV ISTRES pour 1985. Cette nouvelle tranche d'essai s'intitulera phase A 320.

5 - ETUDE DES LOIS DE PILOTAGE CDVE : PHASE A 320 -

Cette deuxième campagne d'essai CDVE au simulateur d'ISTRES a commencé en Avril 1985 et a pour but principal la mise au point de la loi latérale, la loi longitudinale n'ayant que peu changé par rapport à la première phase de 1983.

Le simulateur d'ISTRES étant en configuration A 320, ces essais au simulateur ont également pour objectif de préparer la campagne d'essais sur l'A 300 n°3 qui aura lieu de Décembre 85 à Février 86.

5.1. Lois de pilotage A 320.

5.1.1. Loi de pilotage A 320 en profondeur.

90 % de la loi de pilotage en longitudinal définie en 1983, suite à la première phase CDVE, a été retenue pour l'A 320. (Fig.6)

Les caractéristiques principales de la loi de pilotage manuel de type C^{*} sont :

- . la constance des efforts/G,
- . l'auto-trim,
- . la stabilisation automatique intégrée

Les objectifs de cette loi sont :

- utiliser la loi C^{max} pour améliorer les qualités de vol et réduire la charge de travail,
- augmenter la sécurité en introduisant des protections contre
 - . le décrochage et les gradients de vent,
 - . les facteurs de charge élevés,
 - . les survitesses.
- diminuer les charges en conditions de turbulence forte.

Quels sont les objectifs des protections ?

- a) protection contre le décrochage et les gradients de vent (Voir fig.7).

Cette protection insurpassable :

- . permet d'atteindre et de maintenir la portance maximale $C_z \text{ max}$ sans excéder l'incidence de décrochage manche plein cabré tout en gardant une bonne manoeuvrabilité de roulis à cette vitesse.
- Avec l'activation de l' α floor, cette protection limitant l'incidence assure la meilleure sécurité contre les gradients de vent, à savoir : portance maximale à la poussée maximale.

- b) protection en facteur de charge.

Afin de minimiser la probabilité d'évènements dangereux quand une grande maniabilité est nécessaire, le facteur de charge est limité à 2,5 G pour éviter des dommages structuraux.

- c) protection en survitesse (Fig.8).

Il s'agit de protéger l'avion contre des excursions au-delà de VMO/MMO, en la ramenant dans son domaine de vol normal.

5.1.2. Loi de pilotage A 320 en transversal (Fig.9)

Cette loi a été redéfinie par l'AEROSPATIALE et ses principales caractéristiques sont :

- commande en vitesse de roulis,
- maintien de l'inclinaison en virage à effort nul jusqu'à $\phi = 33^\circ$,
- stabilisation automatique intégrée.

Les objectifs sont :

- amortissement du roulis hollandais,
- virage coordonné avec minimisation du dérapage et du facteur de charge transversal,
- protection pour des inclinaisons latérales au-delà de 75° ,
- contre automatique de la panne moteur.

5.2. Essais en cours.

L'implantation des lois CDVE A 320 au simulateur d'ISTRES a commencé en Avril 85 conformément aux spécifications fournies par l'AEROSPATIALE.

A l'occasion de cet essai et suite aux remarques de la précédente phase (1983) des améliorations ont été apportées :

- un manche latéral fourni par l'AEROSPATIALE et conforme à celui de l'A 300 n°3 a été implanté en place gauche,
- les séances de simulations pilotées se déroulent systématiquement avec visualisation du monde extérieur (NOVOVIEW 2000),
- selon les phases de l'essai, le mouvement cabine peut être utilisé, par exemple pour les approches en conditions de turbulence.

Actuellement la cabine se trouve sur la plateforme à 3° de liberté, mais un couplage temps réel avec le grand mouvement (6° de liberté) est possible moyennant le changement de site de la cabine (délai 5 j).

Côté logiciel, le modèle de vent a été complété et pour les études des protections, les gradients de vent de BOSTON, KENNEDY, ainsi que le modèle de vent CAA, sont disponibles.

5.2.1. Essais effectués.

Depuis juin 85, 40 h de mise au point en 8 séances ont été effectuées au simulateur du CEV ISTRES en collaboration avec les ingénieurs AEROSPATIALE.

L'accent a particulièrement été mis sur la loi en latéral, où 4 standards ont été définis pour être présentés aux pilotes.

A ce jour, seulement les jeux de gains des deux premiers standards ont été réglés :

Std 1	20 h en 4 séances
Std 2	12 h en 3 séances

Le réglage des gains se fait par itérations en optimisant la réponse avion à des sollicitations spécifiques telles que crénaux en ϕ .

Les standards proposés correspondent à des dynamiques plus ou moins lents

Côté loi longitudinale, l'accent est mis sur les protections et à ce jour seulement 8 h de mise au point ont été effectuées.

5.2.2. Essais à venir.

La mise au point des lois va se poursuivre jusqu'en octobre et la présentation des lois aux pilotes pour évaluation aura lieu en novembre 85.

La validation s'effectuera dans un premier temps sans mouvement cabine et en conditions atmosphériques calmes.

Les études d'approches et de décollage avec ou sans perturbations atmosphériques pourront s'effectuer avec mouvement cabine.

La campagne d'évaluation au simulateur à ISTRES sera suivie début décembre 85 d'une expérimentation en vraie grandeur sur l'A 300 n°3, et le simulateur d'ISTRES permettra tout au long de la campagne d'essais en vol de tester et valider les modifications qui seront apportées aux lois avant les vols.

6 - CONCLUSIONS -

Les études, menées au simulateur avion civil à ISTRES en étroite collaboration avec l'AEROSPATIALE ont permis de préparer et de mener à bien la campagne d'expérimentation CDVE sur l'A 300 n°3 en 1983.

Depuis, le développement des lois de commandes de vol électriques pour l'AIRBUS A 320 se poursuit activement et une nouvelle campagne expérimentale est prévue pour fin 1985 (simulateur + avion).

En résumé, le rôle du simulateur d'étude dans le développement des futurs avions de transport civil est sans cesse croissant.

1. MOUVEMENT CABINE A 3 DEGRES DE LIBERTE

- DÉTAILS -

- . Translation Z ± 30 cm.
- . Rotation, Roulis ± 15 degrés.
- . Tangage ± 13 degrés.

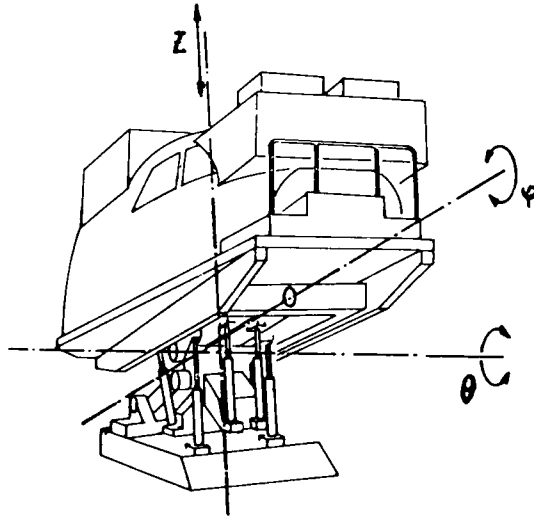

2. MOUVEMENT CABINE A 6 DEGRES DE LIBERTE

- DÉTAILS -

- . Translations X, Y, Z ± 1,80 m.
- . Rotations ± 30 degrés.

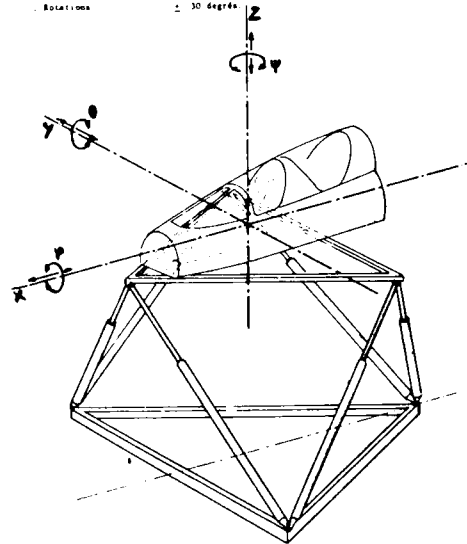

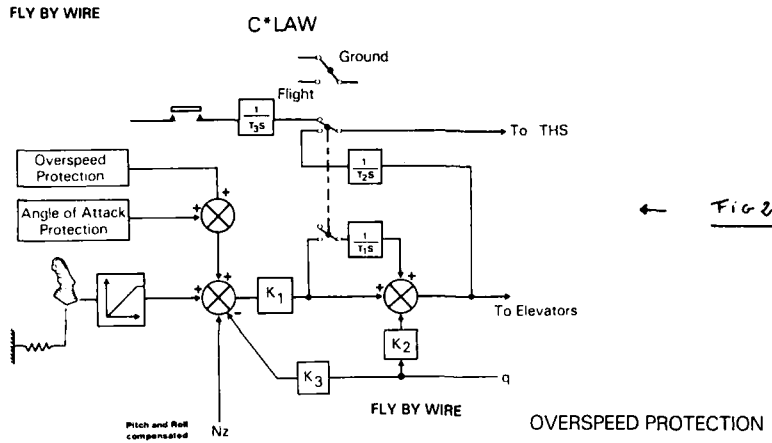

Fig 3 →

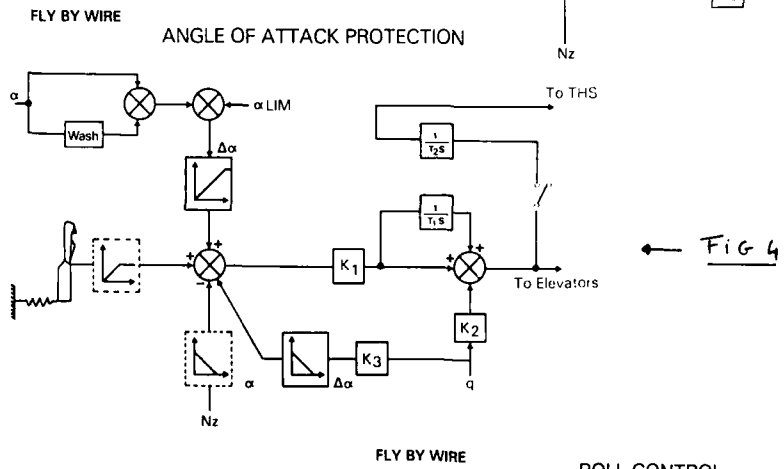
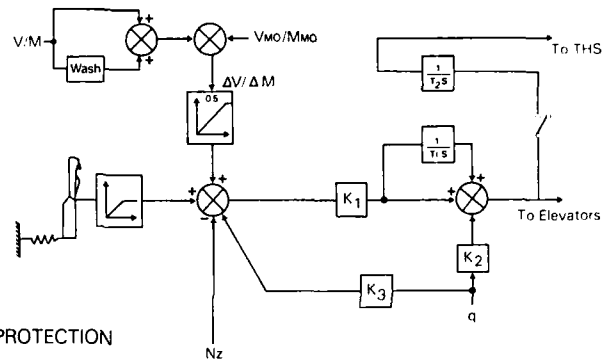
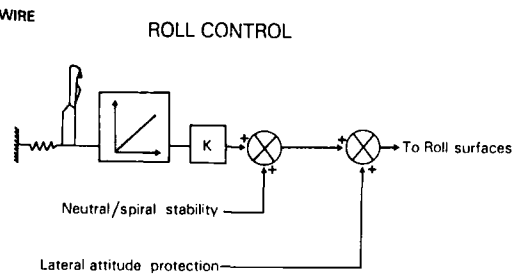
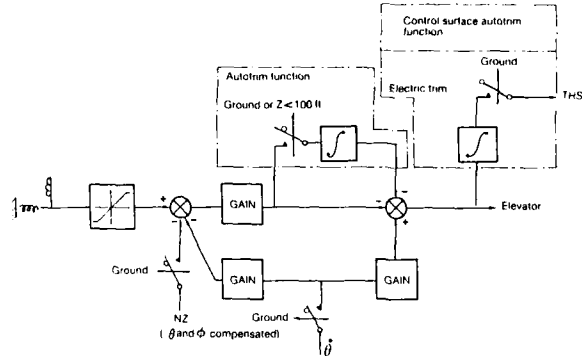

Fig 5 →



A320 C* Law Description



← FIG 6

A320 Protection : Stall and wind shear

FIG 7 →

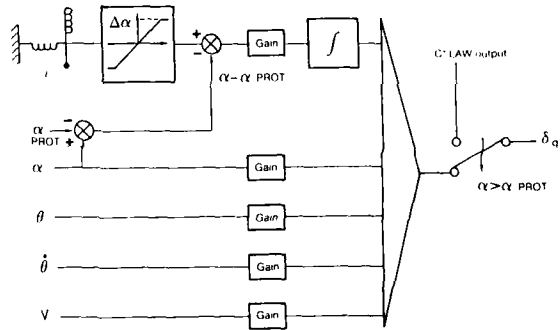

A320 Protection : Overspeed

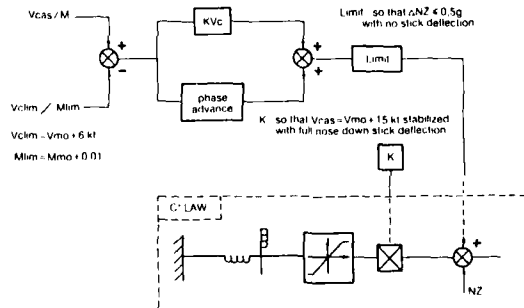

← FIG 8

④ A320 Lateral Control LAW

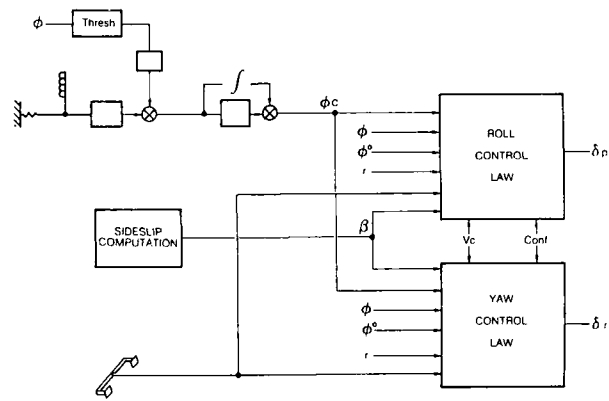

Fig 9

MANNED AIR TO AIR COMBAT SIMULATION

by

Paul A. Patzner
c/o Industriebauanlagen-Betriebsgesellschaft mbH
D-8012 Ottobrunn

Summary

The design and the development of modern fighter aircraft weapon systems has created an ever growing need of simulation activities. Especially manned simulation of combat missions in real time can provide invaluable information to the designing engineers as well as to potential users of such weapon systems. The ground based "Dual Flight Simulator" (DFS) described below simulates air to air combat missions in real time of two different manned aircraft including avionics and armament. Each aircraft is flown by a pilot. The type of aircraft, its avionics and armament can be modelled by exchangeable programs. In order to enlarge realism, the simulation covers a multiple target environment both in the visible range and beyond by IR/RADAR sensors. The engagement scenario includes short range and medium range air to air missiles as well as the gun. The task area of the simulation covers mission performance assessment as well as the investigation of technical components during the research and development phase of future fighter aircraft systems. (ref.1)

1. INTRODUCTION

The design and the development of technical systems, especially modern fixed-wing- and rotary-aircraft, cannot be performed today without the help of simulation techniques. The great progress of aircraft - and outer-space-technology - was only possible by consequently applying simulation techniques at all stages of design, production and inservice-life of flying systems.

In this context simulation may be defined as the technique of modelling a real system by using analogous mathematical, physical or technical relations. The model emerging from this effort allows to study structure and properties of the real system under well defined, reproduceable conditions. In the case of manned simulation the real time aspect and the man-machine interactions of the simulated flight mission are of essential importance to achieve usable results.

Aside from simulators for test and training purposes in later phases of a system's life cycle, simulators for research and development are mainly used in early phases of feasibility-studies of flying systems. Thus, it is possible to gain information early enough to avoid mistakes in the decision on technical solution possibilities. Although many questions in aircraft development can be solved via theoretical calculations and experimental measures using modern computer capacities, the flight properties and mission performance of a new system can only be estimated fairly correctly by taking into account the complete system of pilot-controls-aircraft within the man-machine loop.

As examples the following well known advantages of simulation are quoted:

- exact reproduction and registration of initial conditions, by this means the analysis of the trial conducted and the results obtained is possible
- variation of aircraft parameters to determine optimum values
- investigation of flight behavior in case of failure of certain systems or subsystems, e.g. to classify the question whether the aircraft is still able to fly in such cases. Such investigations can only be undertaken via manned simulation since the risk of a real flight could be much too high
- evaluation of new technologies of flight control and steering
- solution of ergonomic problems.

As disadvantage often proves to be the not yet available real system, that is the question whether it can be produced as proposed.

The manned simulation of air to air combat situations of flying weapon systems has to take into consideration the following problem areas:

- flight properties (carrier, avionics) of the aircraft (controllability, stability, trimming, susceptibility to disturbance): knowledge and simulation of these properties is required as a function of time, pilot's interference and environmental conditions.

- fire control performance (sensors, weapon computer) depending on the type of ammunition, ballistics and kill probability.
- modelling of the military - geophysical environment in connection with different mission areas (threat picture, mission deployment).

Thus, manned simulation - in addition to conventional modelling - has proved to be an excellent tool in solving problems in this area.

2. DESCRIPTION OF THE MANNED AIR TO AIR COMBAT SIMULATOR

The dual flight simulator (DFS) has been developed in the years 1971 - 1975 under the sponsorship of the German MOD to investigate air to air duels. (ref.1) In 1979 - 1982 the simulator has been redesigned to take modern fighter-technology into account. (ref. 4,5,6). The DFS simulates the air combat of two different aircraft systems including avionics and weaponry. One aircraft serves as the enemy system. The other aircraft usually represents the new blue system to be investigated. Additional targets can be generated and displayed. Each aircraft is flown by experienced airforce pilots. The type of aircraft, its avionics and arms are simulated on digital computers by activating relevant software packages. Due to the modular structure of the program these packages can be exchanged easily.

2.1 Design Criteria

Within visual range the air to air combat capacity of fighter aircraft is strongly depending on a good field of view. During air to air combat the pilot estimates his own situation, the position of the opponent aircraft, distance, relative velocity etc. by visual observation. Detection and identification of the enemy is also an optical process. From this the necessity emerges to establish good sighting possibilities from the installed cockpits. Thus, the DFS has a 360° representation of earth/sky/horizon and enemy target around each cockpit (the pilot's eyes being the centre of a 12 m diameter dome). Beyond visual range and in addition to the optical representation of the environment the pilot gathers information about the actual flight situation and the enemy position from various cockpit-instrumentation and displays (Radar, IR, weapons).

Air to air combat results in extreme flight maneuvers of high sequence and strong and lasting acceleration values. The simulation of these maneuvers by cockpit motion is extremely difficult and involves high costs. Therefore the attitude of the aircraft in space is generated by projection systems of sky, earth and horizon as well as the target relative to the fixed cockpit. During air to air combat resulting g-loads are of great importance for the pilot's estimation of his own situation and the assessment of existing limits of the aircraft and the pilot. G-load representation is achieved by dimming the pilot's field of view and subsequently darkening the instrumentation lights from gray-out to the black-out situation. Moreover, the pilot wears an anti-g-suit which generates additional information about existing g-loads. At high angles of attack buffeting often occurs during air to air duels. This effect is also simulated since it may influence the pilot's capability to conduct his task in decisive situations. To simulate buffeting the cockpit is moved and shaken by an electro-hydraulic device.

The above mentioned phenomena are simulated in accordance with the actual flight situation. Taking all effects into account the pilot gathers the impression of real-flying.

2.2 The Structure of the Simulator

The principal structure of the DFS is shown on figure 1. Both cockpits are situated in the centre of spherical projection domes to allow for sighting simulation. Above each cockpit projectors are mounted to generate earth-sky-horizon and target-images. The computer room at the opposite side of the hall contains four digital computers, an analog computer, electronic interface equipment for cockpits, sighting systems and the steering console of the DFS. The logical flow chart of the DFS is shown on figure 2. As the figure demonstrates, there are two complete weapon systems simulated simultaneously.

2.3 Components of the Simulator

2.3.1 Cockpits (ref.2)

The DFS consists of two reconstructed F-86 cockpits to establish a relatively great field of view for pilot's vision in air to air duels. By masking, the field of view of the cockpit can be adjusted to the actual field of view of the aircraft simulated. The cockpits have been standardised as far as possible to simulate different aircraft. All navigation instrumentation has been deleted. An electronic Head-Up-Display (HUD) reveals flight and weapon data. Two electronic display units below (Head-Down-Displays) deliver additional weapon- and/or mission-specific information, e.g. range of IR-missiles, RADAR-modes etc.

In front of the pilot's view a RADAR and IR-warning gear is placed. Most of the displays are coupled to a symbol generator which can be programmed according to aircraft specific symbology. Pilots may choose different modes of operation as provided by the type of aircraft. All functions can be activated according to the HOTAS- (hands on throttle and stick) principle. The fire control device enables the pilot to fire gun rounds, launch guided or unguided missiles or bombs.

2.3.2 Control Force Feeling System

A hydraulic force generator for all three controls is available for simulating the control forces. An electronic network calculates the travel of the controls from the forces measured at the stick and pedals in correspondence with the predetermined force gradients and the current g-load. Aircraft-type-dependent functions, such as serial or parallel trim, and the dynamic pressure dependence of the force deflection characteristic as well as "shaker" and "kicker" can be taken into account.

The electronic network of the control-force feeling system contains a complete second-order model of the control dynamics so that their mass and damping can also be simulated exactly. This design makes it possible to simulate a double stick (for two-seaters) without any hardware modification. If necessary, the travel limits of the controls can be modified in dependence on the flying status. Calibrating the control-force behaviour on the basis of pilot's commands can be rapidly achieved by using-high-precision potentiometers in direct dialog.

To protect the pilot, a safety circuit has been installed.

2.3.3 Buffeting

Buffeting is simulated by a hydraulic motion system that moves the entire cockpit in the Z-axis. This design serves to avoid pilot-induced oscillations. The simulated buffeting reproduces the real buffeting in the 3-15 Hz frequency band. The maximum acceleration is $\pm 1g$. The frequency distribution can be adjusted to take into account the natural frequency of the aircraft type tested. The electronic network can simulate up to three natural frequencies, with the resonance peaks and damping values being individually adjustable. The resonance peaks can be adjusted depending on the flying status. Additionally, the system can be used to simulate individual vertical shocks of small amplitude. A safety circuit protects the pilot by controlling the travel and velocity of the cockpit.

2.3.4 G-Load-Simulation

Actual g-loads do not exist in the simulator because the motion system has been omitted. Instead a g-suit is used to simulate these loads on the basis of pilot's practical experiences. His professional background enables the pilot to interpret the pressure transmitted by the g-suit as information on the acceleration he is subject to. This effect is increased by the simultaneous simulation of the gray-out, i.e. the gradual darkening of all lamps and projectors, down to total blackout.

2.3.5 Visual Systems

There are three projectors in each DOME casting a picture of sky, earth-horizon, the manned fighter target image and an additional light spot onto the spherical, diffusely reflecting screen of 12 m diameter. The earth-sky-horizon projector, casts a colored 360-degree image on the screen. This is superimposed by the target image produced by the target projectors. The projections combine to provide a realistic impression of the scene of action which is limited only by the cockpit itself. The earth-sky-horizon image is produced by transparency projection without additional optics. For this purpose the rays of a point-light source penetrate transparent colored spheres. A four-axis gimballed system enables the projector to simulate all angular movements of the aircraft. The projectors are controlled via high-resolution DC servos whose control signals are calculated on the basis of the relative positions and attitudes of both aircraft by a special program, the Sight Model.

The projectors are driven by servo motors using a pulsemodulated technique. For high accuracy and dynamic performance, velocity feedback is used in addition to position transducers. The target image is produced by superimposing a black- and white TV image onto the colored earth-sky-horizon image. The pictures are taken from an exchangeable aircraft model suspended in a gimballed system, which admits an unimpeded view of the model from all directions. The video signal is conducted, via a closed-loop-circuit TV system, to a high-resolution cathode ray tube and projected onto the screen by special optics and two rotating mirrors. The additional light spot projector provides an extra computer generated target within the scenario. If needed a helmet mounted sight can be used in one cockpit.

2.3.6 Sound Generator

To complete the impression of the outside world, flight noise is produced by a sound generator. The noise generated is aircraft-type-specific and also dependent on flying status and weapon deployment. For this purpose, available original sound recordings are analyzed semi-automatically to obtain the spectral data the generator uses. Then the desired noise is generated by synthesis. A subsystem attached to the sound generator produces the acoustic signals needed for angle-of-attack warnings and weapon lock-on. The

sound generator produces - for each aircraft and dependent on its flight status - noise in the 20 Hz - 10 kHz spectrum with a resolution of 8 Hz and 80 dbA maximum intensity. Sound synthesis is achieved on the basis of the current control input values. For this, a maximum of eight analog and sixteen discrete input channels are available.

2.4 Software

For simulating two different types of aircraft, a real-time program has been developed which consists of a type-independent control part and two type-specific parts to represent the flight mechanics, armament and avionic systems. With this modular structure, the program can be quickly adapted to different types of aircraft, with clearly defined interfaces and data specifications. The type-independent control part of the program provides the logic structure for the overall simulation model. The control part initiates the real-time parameters and functions and sets the constants for each simulation run. During simulation this part keeps a constant check on the program to assure that the real-time conditions are met. At the same time, the control part organizes and supervises the data flow between the computers and the cockpits. Those parts of the overall program that are type-specific are generated by a generally applicable flight-dynamics standard program called FLUGSIM. This 6-DOF program is so structured as to cover any conceivable special configuration, physical effects and singularities. The result of this program concept is that a three-engine asymmetric aircraft allowing the arrangement of any desired rotating components has been programmed. In order to evade possible singularities in flight mechanics, quaternions are used instead of Euler angles. Also taken into account by the program are the landing gear forces and moments, although the DFS does not require that take-off and landing be considered. So, this standard program will be able to generate any aircraft configuration in a minimum of time by cutting off all subroutines that are not required. This approach serves to keep the programming and data volume as low, and the interfaces as clear, as possible. As far as the flight-mechanics aspects of the program are concerned, the subroutines for aerodynamics, engine fuel and armament management, flight-control system, and actuator-control servo must be newly programmed or modified for each type of aircraft. The subroutines for armament and the avionic system are defined by clear interfaces within the total program structure, so they may be exchanged without any modification to the rest of the program.

2.5 Simulation und Evaluation

The entire process of simulation is controlled and supervised from the control console. The initial conditions of a simulation run are put in via computer terminal in dialog operation. Once the resulting stationary flight data have been calculated, the pilots take over the aircraft which has been trimmed for these initial conditions. A simulation run can be frozen or cancelled any time from the control console. A new simulation may be initiated after stopping the previous simulation. Capabilities available for recording data include:

Digital recording on magnetic tape, analog on paper recorder.

In principle, all parameters calculated by the simulation models can be recorded. Since the writing velocity of the digital tape recorder is fixed, only a limited set of such parameters can be recorded. The number of parameters that can be registered depends on the output cycle time. This cycle time is selectable within a range from approximately 50 msec to 1 sec. The numbers of parameters recorded per weapon system are: 30 to 500.

The simulation runs are evaluated by processing the data recorded during the runs. Possible evaluation outputs are:

- Engagement summaries
- Time plots of one or more parameters
- Cumulative distributions
- Relative distributions
- Mean values and standard deviations, etc.

For editing and evaluating the magnetic-tape-recorded data, the evaluation program system (APS) provides a number of evaluation and utility programs. APS consists of an organizational part for selecting and handling data, and a specific evaluation part. APS is handled interactively in dialog mode. (ref. 3)
For special purposes a full color graphical TV-System (RAMTEK) can be used in on-line and off-line modes.

3. CONCLUSIVE REMARKS

3.1 Pilot judgement

Before the DFS is deployed, the properties of the aircraft to be investigated are installed and adjusted according to the pilot's judgement until the simulator behaves as closely as possible to the actual aircraft. Experienced testpilots of the producer company, official testpilots and/or air force pilots are employed to accomplish this final modification of the system. In most cases only minor modifications have to be conducted and pilots judge the flight behaviour of the simulator similar to the original aircraft. The use of cockpits, the closing of the hub, wearing of helmet and oxygen mask create a realistic environmental impression. Displays, sighting devices, target image projection and movement of the image, buffeting, anti-g-suit, gray-out simulation etc. and the tactical task to be fulfilled cause an almost realistic impression of actually flying.

3.2 Past investigations

The following types of aircraft including their weaponry are integrated: F104 G, F4F, MRCA, 3-Jet, MBB-TKF, F106 A, F18, Enemy I and II. Over the past ten years a number of successful studies have been conducted on various fighter-aircraft designs both on national and multilateral level. The results of these studies are classified and cannot be discussed within this paper. The sponsor of the studies has pointed out how useful the investigations have been. Only after the manned simulation runs the system capability could be evaluated correctly. Moreover, the manned simulation is necessary for project support, flight test support, the solution of technical, ergonomical, tactical and other configuration questions.

3.3 Cost Benefit aspect

A considerable amount of material, time, finances and scientific expertise has to be invested to design, build and operate a manned simulator. This fact initiates always discussions on the usefulness of such technical equipment.

Without elaborating the topic in detail, the following statements are quoted:

- Even high simulation costs pay off if the development risk of a new system can be narrowed. By making this risk small a lot of financial resources can be saved.
- Compared with actual development costs and fly away prices of present aircraft the costs of successful manned simulations to provide relevant results are small.
- During times of low financial resources simulation is an excellent tool to gain lacking information in the decision making process on future flying weapon systems.

4. REFERENCES

- | | |
|--|--|
| (1) P. Sepp
J. Weickhardt
W. Schattenmann
et. al. | "Abschlußbericht DFS"
IABG Ottobrunn, B-WT 3048-01/02/03/04
v. 15.12.1976 |
| (2) H. Kohler | "Entwicklung eines variablen Simulations-
cockpits", IABG Ottobrunn,
M-WT 3063-01 v. 29.05.1980 |
| (3) K. Gneiting | "Programmbeschreibung der WTS-
Schnellauswertung für die Studie
TKF 90 Phase I", IABG Ottobrunn,
B-WT 3069-01 v. 13.09.1979 |
| (4) H. Kohler/
R. Lautenschlager | "Umrüstung DFS - Minimallösung -",
IABG Ottobrunn, B-WT 3107-01
v. 21.12.1981 |
| (5) H. Kohler | "Herstellung der Nutzungsreife
- DFS Hardware -", IABG Ottobrunn,
B-WT 3112-01 v. 10.11.1982 |
| (6) H. Kohler | "Umrüstung DFS", Teil I und II,
IABG Ottobrunn, B-WT 3114-01
v. 30.06.1983 |

Figure 1:

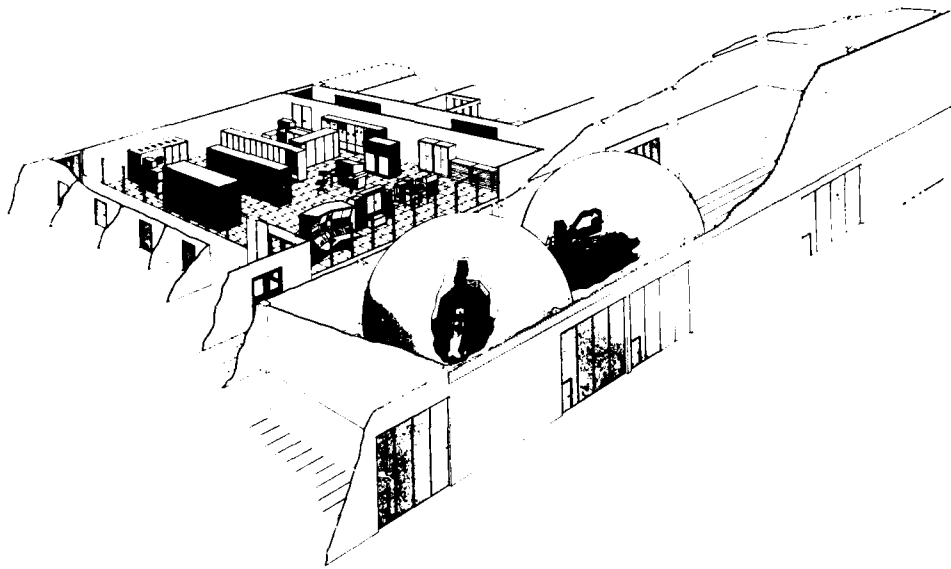
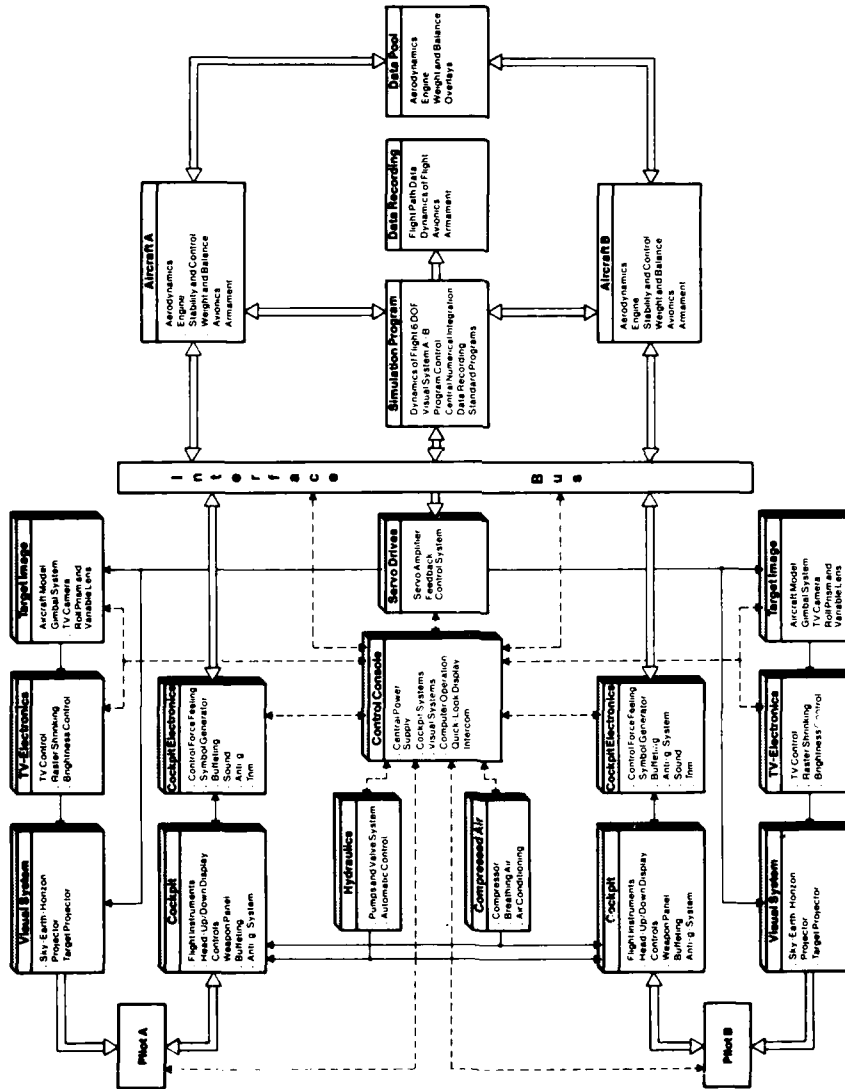

Figure 2:



Utilization of Simulation To Support F-14A
Low Altitude High Angle of Attack Flight Testing

by

P. Conigliaro,

R. Goodman

Flight Test Department

Grumman Aerospace Corporation
 South Oyster Bay Road
 Bethpage, NY 11714

SUMMARY

Ground-based flight simulation has been used successfully to support low altitude, asymmetric thrust, high angle of attack flight testing of the Grumman/Navy F-14A. The high risk nature of this flight testing, while representing a prime example of the application of simulation in the flight test environment, nonetheless generated particular problems regarding simulation fidelity and utilization requirements. As a result, new simulation capabilities were developed specifically for flight test support applications and were fully integrated into existing flight test computing/ data analysis facilities. Results from the F-14 high angle of attack flight testing are used to illustrate how simulation can significantly enhance overall flight test safety and productivity. Using simulation support, an efficient test program was completed on time and allowed the F-14's departure characteristics to be safely demonstrated at angles of attack greater than 60 degrees with full engine thrust asymmetry at altitudes below 10,000 ft (3030 m).

INTRODUCTION

The loss of several F-14A aircraft in apparent spin-related accidents during 1976-79 prompted the United States Navy to initiate a series of flight test programs with Grumman Aerospace Corporation to investigate the high angle of attack departure characteristics of this twin engine, variable-sweep fighter. Due to the F-14's wide engine spacing, particular emphasis was placed on determining the contribution of engine thrust asymmetry to loss of aircraft control at elevated angles of attack. A piloted high angle of attack engineering simulation was developed to evaluate the F-14's departure tendencies and utilized throughout a successful 1980-81 flight test program to enhance overall test safety and productivity. While valuable high angle of attack data was obtained during this flight program, the aircraft's departure characteristics were evaluated only at high altitude due to the inherent risk of flying dynamic high angle of attack maneuvers at lower altitudes.

To further define the F-14's high angle of attack departure characteristics in the low airspeed/low altitude flight regime where asymmetric thrust is most critical, the Grumman-Navy Low Altitude Asymmetric Thrust program was conducted during 1983-84. Ground-based simulation was again utilized to support all flight test activities. However, the risks of high angle of attack departure testing at low altitude necessitated an increased reliance on the simulation's ability to accurately, but conservatively, predict the F-14's departure characteristics. The simulation fidelity requirements were therefore more stringent for this program. An extensive simulation improvement effort had to be undertaken before flight testing could commence. Once adequate simulation fidelity improvement had been achieved, an intensive piloted simulation effort was conducted in a newly operational fixed base simulator designed specifically for flight test support and fully integrated into the Grumman Flight Test Department's computing/data analysis facilities. The results of the simulation effort were then used to define critical low altitude departure boundaries and to establish criteria under which a safe and efficient flight test program was successfully completed.

This paper reviews the technical considerations in applying ground-based piloted simulation to support F-14A high angle of attack flight testing in general, and the Low Altitude Asymmetric Thrust test program, in particular.

BACKGROUND

The F-14A, shown in Fig. 1, is the U.S. Navy's twin-engine, variable-geometry, carrier-based multi-role fighter aircraft. With its variable wing sweep, enhanced lift/maneuver devices (auto slats and flaps), body-lift glove fuselage configuration, and all-movable, fully exposed horizontal tail surfaces, the F-14 has a large opera-

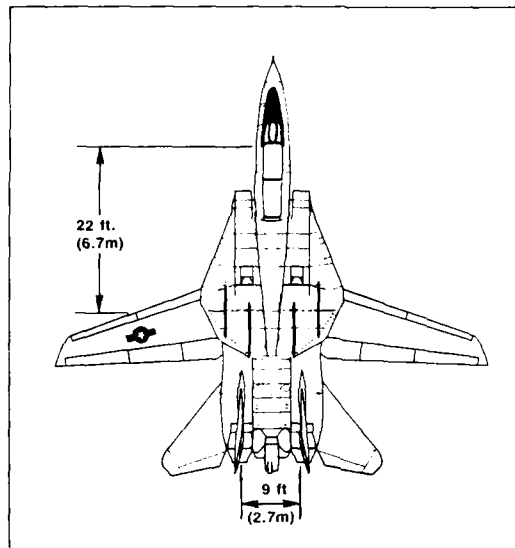

Fig. 1 Plan-View Drawing

tional flight envelope extending in angle of attack well beyond maximum lift and free of any longitudinal stability and control restrictions. While departure resistant throughout its flight envelope, the F-14 -- like many modern fighter aircraft -- exhibits degraded lateral-directional characteristics at high angles of attack. These include roll reversal, wing rock, and decreased directional stability. Directional stability characteristics at high angles of attack are further degraded as external stores are added to the aircraft. Carriage of multiple external stores was a common factor noted in many reported spin-related accidents. Another common factor noted in at least nine departure/spin incidents was the presence of an engine thrust asymmetry. The F-14's unusually wide engine spacings of approximately 9 ft (2.7 m) create the potential for large thrust asymmetries should a single engine fail or stall in flight. The large yawing moment produced by the thrust asymmetry can significantly affect the aircraft's high angle of attack flight characteristics, particularly if the operating engine is in full afterburner.

A prime concern in F-14 departure testing, however, is the effect on the pilot should a test maneuver depart inadvertently into a high yaw rate spin. The length of the cockpit to center-of-rotation moment arm in the F-14 -- about 22 ft (6.7 m) assuming the aircraft spins about its center of gravity -- generates large and potentially debilitating longitudinal accelerations on the pilot at high yaw rates (so-called "eyeball out" gs). As shown in Fig. 2, the cockpit longitudinal gs predicted using this 22 ft moment arm assumption correlate extremely well with actual flight measured test data. The effects of increasing longitudinal gs on a pilot, as determined from centrifuge tests conducted in the early 1970's, are also indicated on Fig. 2. Those tests showed that as longitudinal gs increase, the pilot begins to have difficulty in moving the aircraft controls due to pain caused by blood pooling in the extremities. As longitudinal gs increase still further, the pilot may no longer be able to move his controls or even to initiate emergency ejection and soon begins to suffer eye damage. Unfortunately, those disabling effects have been demonstrated in flight by a Navy test pilot when his F-14 test aircraft achieved yaw rates estimated as high as 180 degrees per second. After several seconds at high yaw rates, he was unable to input full recovery controls and, in fact, suffered some temporary eye damage in the form of ruptured eye blood vessels. Fortunately, the longitudinal g levels were lower at the rear cockpit and the weapons officer was able to command emergency ejection for both crew members.

Therefore, the problem facing the Grumman/Navy test team -- tasked with developing the F-14 high angle of attack departure programs -- could be best summarized as how to safely, yet efficiently, investigate departure boundaries of an aircraft with spin characteristics that can quickly disable the test pilot. The use of ground-based piloted simulation provided one solution to this problem. Specifically, a test approach was developed in which simulation would be used to first predict the F-14's high angle of attack departure and recovery characteristics, with the simulation results subsequently verified through limited flight test investigation integrally conducted with the simulation support. The basic groundwork for this integrated simulation/flight approach to high risk flight testing was first established at the National Aeronautics and Space Administration (NASA). NASA had, in fact, made extensive use of

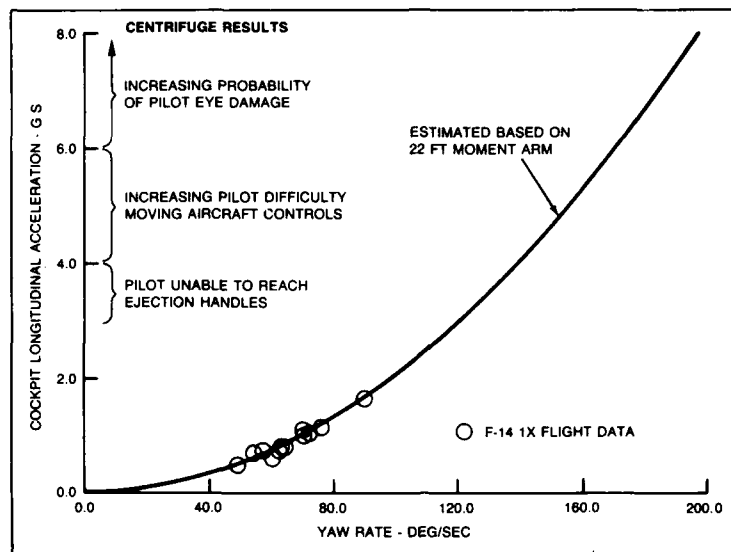

Fig. 2 F-14A Spin Characteristics at Front Cockpit

piloted simulation to support earlier F-14 high angle of flight research (References 1-3). The main focus of those previous NASA efforts, however, had been with the development and evaluation of an Aileron-to-Rudder Interconnect (ARI) system for the F-14 to prevent control-induced departures. The Grumman/Navy test programs, in contrast, would actively seek to define specific high angle of attack departure boundaries and to identify the contributory factors in F-14 departures, including the effects of external stores and asymmetric thrust.

F-14 ASYMMETRIC THRUST/STORES TEST PROGRAM

The F-14 Asymmetric Thrust/Stores test program (References 4 and 5) was the first of the Grumman conducted high angle of attack simulation and flight test programs. A piloted high angle of attack simulation model was developed and implemented for this program on the Grumman Engineering Department's hybrid simulation facility in Bethpage, NY, located some fifty miles distance from the Calverton Flight Test Center from which all the program's test flights were conducted. While this off-site simulation did present travel and logistics problems to the test team members supporting both the simulation and flight test efforts, the simulator was nonetheless utilized extensively during this successful 1980-81 test program. Over 2000 total maneuvers were "flown" on the simulator and involved virtually all aspects of the flight test activities from initial test planning to postflight maneuver analysis. The benefits accorded the test program by utilizing piloted simulation support for such high risk flight testing quickly became evident and are reviewed briefly.

Flight Test Planning

To properly define the F-14's high angle of attack departure characteristics, a large matrix of test maneuvers involving all possible combinations of pilot control inputs had to be evaluated across a wide range of Mach numbers and angles of attack. While this matrix of maneuvers would have been prohibitively large to test in flight, in the simulator it was flown and analyzed in a relatively quick and efficient manner. From the simulation results, the critical aircraft departure parameters were readily identified and the significant departure trends defined. Once the simulation test matrix had been reduced and quantified, the aircraft flight test plan was generated in a form optimized to meet the program's test objectives. All non-productive test maneuvers identified on the simulator were eliminated and the number of build-up maneuvers -- normally required in flight to allow safe approach to critical test conditions -- were limited to only those sufficient to verify the simulation results. Thus, more maneuvers in the final aircraft test plan were dedicated to accomplishing the critical program demonstration endpoints.

Flight Test Efficiency

Utilization of piloted simulation for flight test support also increased the efficiency with which the planned test points were achieved in flight. High angle of attack maneuver entry and other piloting techniques were evaluated and refined first on the simulator so that little if any flight time was lost doing so. Pilot proficiency was further enhanced by using the simulator to rehearse each flight's set of maneuvers

AD-A173 875

FLIGHT SIMULATION(U) ADVISORY GROUP FOR AEROSPACE
RESEARCH AND DEVELOPMENT NEUILLY-SUR-SEINE (FRANCE)
A M COOK ET AL. SEP 86 AGARD-CP-408

3/4

UNCLASSIFIED

F/G 5/9

NL

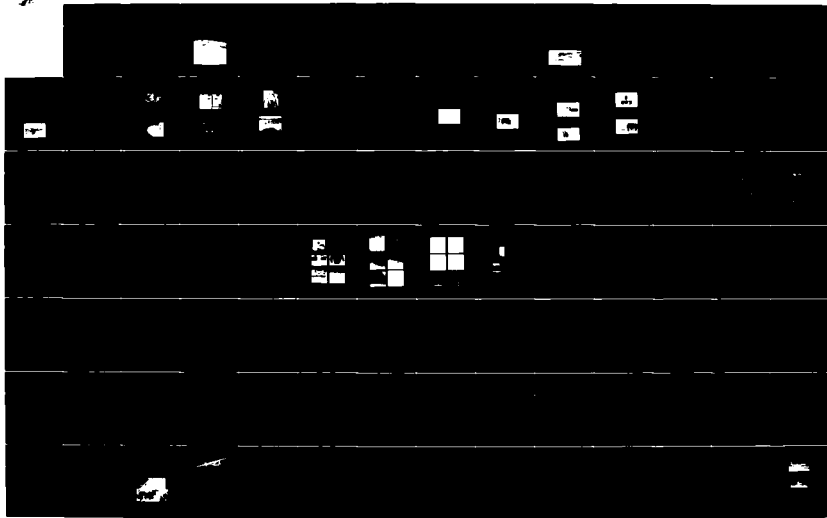

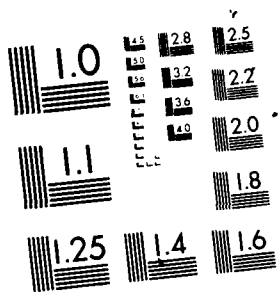

MICROCOPY RESOLUTION TEST CHART
NATIONAL BUREAU OF STANDARDS 1963-A

immediately prior to the test flight, thereby helping to reduce the number of repeat maneuvers required in flight. Proper maneuver technique and increased pilot proficiency were of crucial importance in achieving overall test efficiency in this program since control inputs were performed at very specific sets of flight conditions during dynamic, large amplitude aircraft maneuvering at extreme angles of attack and sideslip.

Flight Test Safety

Unquestionably one of the most significant benefits achieved through piloted simulation support is enhanced flight safety. The simulator was used to establish safety of flight criteria appropriate for the high angle of attack departure tests, including minimum altitudes/maximum rates for test maneuver termination, spin-chute deployment, and emergency ejection. Different recovery techniques were evaluated on the simulator and recoveries practiced from a variety of different "worst case" scenarios. The rehearsal of maneuvers on the simulator prior to flight also tended to enhance flight safety by providing a definite focus on the current flight's set of maneuvers, predicted results, and potential hazards. Finally, the simulation results provided what might best be termed as "benchmarks of safety" to proceed with the testing. As long as the simulation predictions continued to show conservative agreement with the flight results, the aircraft testing could proceed safely to the next test point. In this way, the level of flight safety maintained during the high risk testing was continuously monitored throughout the flight program on a maneuver-to-maneuver basis.

The overall benefits afforded the F-14 Asymmetric Thrust/Stores test program by piloted simulation support can be quantitatively assessed from the program results summarized in Table 1. The successful completion of the F-14A Asymmetric Thrust/Stores program clearly demonstrated that the integration of ground-based simulation with high risk flight testing provided significant benefits in terms of program planning, safety, operations, and data analysis. It also helped to convince the Grumman Flight Test Department of the need for a simulation capability located on-site at the Calverton flight test facility and dedicated as a flight test resource to support of future flight test activities.

Table 1 F-14A Asymmetric Thrust/Stores Program Summary

• OBJECTIVE: SAFELY DETERMINE EFFECTS OF THRUST ASYMMETRY & STORE LOADINGS ON:		
	- BOUNDARIES OF CONTROLLED FLIGHT	
	- HIGH ANGLE OF ATTACK DEPARTURE CHARACTERISTICS & RECOVERY TECHNIQUES	
• ESTIMATED NUMBER OF MANEUVERS & FLIGHTS REQUIRED WITHOUT SIMULATION	600/100	ENHANCED FLIGHT PRODUC- TIVITY
• TOTAL NUMBER OF MANEUVERS FLOWN IN SIMULATOR	2000+	
• ACTUAL NUMBER OF MANEUVERS & FLIGHTS FLOWN IN TEST AIRCRAFT	314/49	
• NUMBER OF REPEAT MANEUVERS REQUIRED IN FLIGHT	1	
• NUMBER OF ABORTED MANEUVERS OCCURING IN FLIGHT	0	
• MAXIMUM FLIGHT CONDITIONS OBTAINED:		ENHANCED FLIGHT SAFETY
- ANGLE OF ATTACK	80°	
- YAW RATE	90°/sec	
- ANGLE OF SIDESLIP	50°	
• TOTAL NUMBER OF ENGINE STALLS EXPERIENCED	50	
• NUMBER OF EMERGENCY RECOVERY DEVICE DEPLOYMENTS (SPIN CHUTE, CANARDS, EPU)	0	

FLIGHT TEST FIXED BASE SIMULATOR

A design and development effort was therefore undertaken to implement a piloted, all-digital, fixed base flying qualities simulator to be fully integrated into the existing flight test computing facilities at Calverton. The design philosophy for the simulator was simple: have experienced flight test people develop a simulation capability appropriate for use in the flight testing environment and dedicated to flight test program support. Design emphasis for the simulator was placed on operational functionality and flexibility, not on elaborate, expensive and/or hard-to-maintain simulation hardware facilities. After an approximate one year design, fabrication, and validation effort, the Flight Test Fixed Base Simulator (FTFBS) was deemed operational. A schematic of its integration into the flight test ground station facilities is presented in Fig. 3 and a view of its cockpit section in the F-14 configuration is shown in Fig. 4.

The primary features to note in the simulator's cockpit section are the basic design of the instrument panels and the pilot's touch-sensitive control console. The FTFBS cockpit layout represents the instrument panel configuration of the F-14 test aircraft used in the high angle of attack departure testing. However, only those cock-

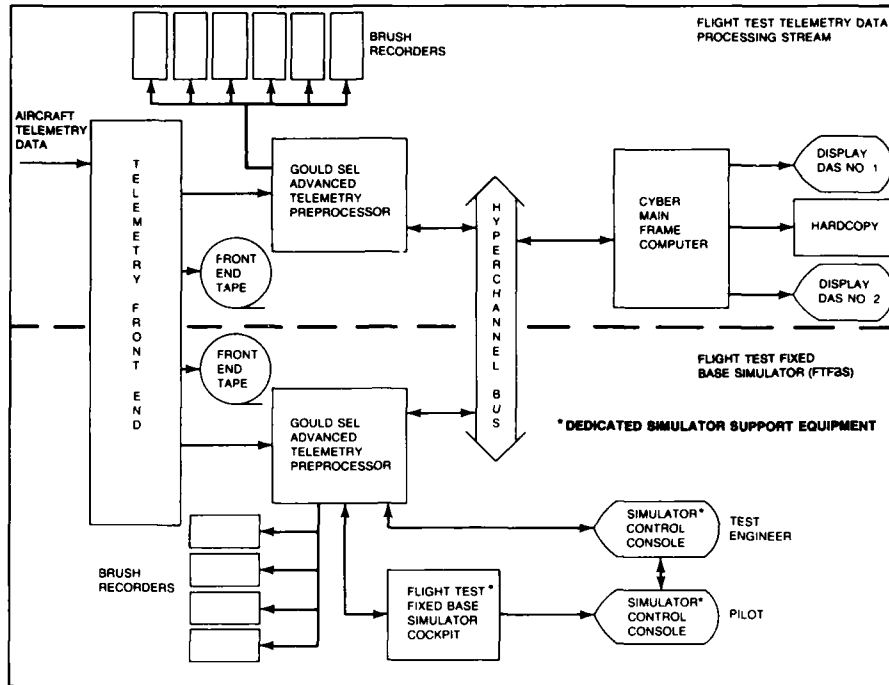

Fig. 3 Schematic of FTFS Integration into Existing Telemetry Processing/Ground Station Facilities

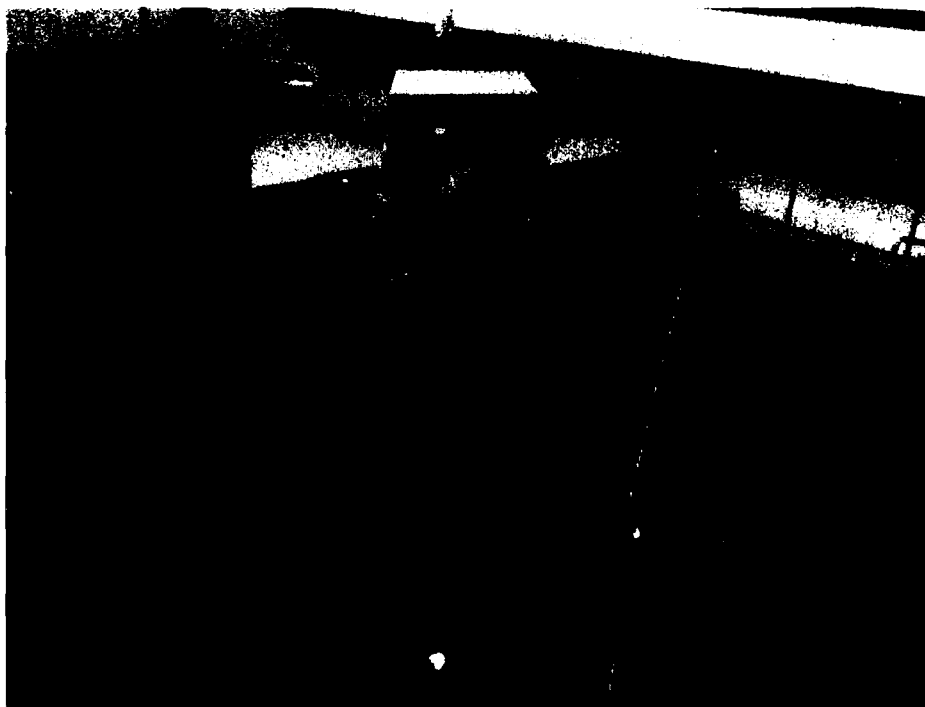

Fig. 4 FTFS Cockpit Section in F-14 Test Aircraft Configuration

pit gauges required by the pilot to perform flying qualities/departure simulation are duplicated in the simulator, thereby simplifying the FTFBS cockpit design. The straightforward mechanical design of the panel and modularized electrical interfaces allow rapid changeover between different simulator cockpit configurations (under 30 minutes). This also helped to keep simulation development costs down. The pilot's touch-sensitive display console is one of two FTFBS control terminals and allows all simulator realtime operations to be controlled from the cockpit via its variable multiple-menu display/selection format. This feature permits the simulator to be completely operated by a single person if necessary. When a full test team is available, however, the normal maneuver-to-maneuver simulator operations can be controlled by the pilot, leaving the test engineers free to concentrate on analysis of simulator output data. A test engineer's simulator control console is also available and duplicates all functions on the pilot's touch-sensitive display as well as providing several additional features useful to the test engineer for data analysis and for rapid on-line model/database reconfiguration purposes. A complete summary of the FTFBS hardware and software features is provided in Tables 2 and 3, respectively.

All these features combine to give the FTFBS operational flexibility and functional utility appropriate for flight test support applications. It was not long before these capabilities were called on to support additional F-14A high angle of attack departure testing.

Table 2 Flight Test Fixed Base Simulator (FTFBS) Hardware Features

- FIXED BASE WITH STANDARD FULLY ADJUSTABLE EJECTION SEAT
- McFADDEN LOADER SYSTEM (NAVY HIGH ROLL STICK) FOR CONTROL STICK & PEDAL CHARACTERISTICS
- SIMULATOR COCKPIT PANELS CONFIGURED TO SPECIFIC TEST AIRCRAFT
- RAPID PANEL CHANGE-OVER THROUGH MODULARIZED DESIGN & QUICK DISCONNECT ELECTRICAL INTERFACES
- DUAL OPERATIONAL CONTROL VIA SEPARATE PILOT & TEST ENGINEER CONSOLES
 - PILOT'S CONTROL VIA TOUCH-SENSITIVE MULTI-MENU CONSOLE (ALLOWS 1 MAN OPERATIONAL CAPABILITY)
 - TEST ENGINEER'S CONSOLE PROVIDES ADDITIONAL REAL-TIME DATA STORAGE/RETRIEVAL & INTERACTIVE MODEL/DATABASE RECONFIGURATION CAPABILITY
- COMPREHENSIVE HARDWARE VALIDATION & DIAGNOSTIC CAPABILITY BUILT-IN
- TIED-IN TO CURRENT FLIGHT TEST GROUND STATION DATA ANALYSIS & ICS FACILITIES
- GOULD SEL 32/8750 DIGITAL COMPUTER OPERATING THROUGH FLIGHT TEST TELEMETRY PROCESSING STREAM

Table 3 FTFBS Software Features

- GENERIC REAL-TIME SIMULATOR OPERATING SYSTEM
- MODULARIZED, MULTI-LEVEL SIMULATION SOFTWARE STRUCTURE
- MATH MODEL/DATABASE VALIDATION CAPABILITY & CONFIGURATION CONTROL
- EXTENSIVE SIMULATOR DATA CONTROL, STORAGE & RETRIEVAL
 - ON-LINE DATA ROUTING/SCALING TO MULTIPLE DATA DISPLAY DEVICES RESIDENT IN FLIGHT TEST GROUND STATION
 - RAPID ON-LINE MODEL/DATA BASE CONFIGURATION CHANGE-OVER CAPABILITY
- EXTENSIVE MANEUVER ANALYSIS CAPABILITIES
 - INTERFACE WITH REAL-TIME FLIGHT TEST DATA ANALYSIS SOFTWARE
 - STOP ACTION "RUN/HOLD/RUN" REAL-TIME CONTROL FEATURE
 - "CAPTURE" OF DYNAMIC FLIGHT CONDITIONS FOR USE AS INITIAL CONDITIONS FOR SUBSEQUENT MANEUVERS
 - PLAYBACK OF STORED MANEUVER DATA THROUGH COCKPIT GAUGES IN REAL-TIME
 - RERUN (REFLY) EXISTING MANEUVER WITH DIFFERENT MATH MODEL/DATA BASE CONFIGURATIONS USING RECORDED PILOT INPUTS AS FORCING FUNCTIONS
- AUTOMATIC SIMULATION SESSION MANEUVER SUMMARY/RUN LOG OUTPUT

LOW ALTITUDE ASYMMETRIC THRUST PROGRAM

In February, 1983 an F-14 was lost during air combat training in a low altitude departure accident in which asymmetric thrust was suspected to be a contributing factor. This accident reiterated the need for a follow-on high angle of attack test program to further define the F-14's departure characteristics in the low airspeed/low altitude flight regime. While valuable high angle of attack test data had been obtained during the Asymmetric Thrust/Stores program, the evaluation of the F-14's departure characteristics had to be restricted to altitudes greater than 30,000 ft (9100 m) for flight safety reasons. This left its departure characteristics in the lower lefthand corner of the flight envelope relatively unexplored. This is precisely the flight regime where asymmetric thrust is most critical, however, due to the higher thrust levels possible at low altitudes and the reduced aerodynamic recovery control effectiveness present at low airspeeds. The loss of this aircraft provided an increased impetus for Grumman and the Navy to conduct a low altitude, asymmetric thrust, high angle of attack flight test program for the F-14.

The F-14 Low Altitude Asymmetric Thrust (LAAT) program (Reference 6) was conducted during 1983-84 to further define the F-14's high angle of attack departure characteristics at altitudes lower than had ever been previously tested. As was the case during the Asymmetric Thrust/Stores program, piloted simulation would again be extensively utilized for test planning and flight support purposes. However, due to the inherent risk of flying dynamic high angle of attack maneuvers at low altitudes, flight safety requirements dictated an increased reliance on the simulation's ability to accurately predict the F-14's departure and recovery characteristics. The hazardous nature of the low altitude flight tests therefore generated simulation fidelity requirements far more stringent than those in the earlier program. As a result, an extensive F-14 simulation model improvement effort had to be undertaken before flight testing could commence.

Simulation Model Updates

The F-14 high angle of attack math modeling developed during the Asymmetric Thrust/Stores program served as the basis for all modifications required for the LAAT program. The simulation modifications involved the following aerodynamic and propulsion model updates:

Engine Thrust Model - The old engine model contained data for early production TF30-P-412 engines at zero angle of attack only. The LAAT engine model updates included performance data for the current F-14 production TF30-P-414A engines as well as angle of attack effects on installed net thrust and associated propulsive losses (inlet pressure recovery and ram, spillage, interference drags). In addition to the updated thrust and drag data, the effects of the engine Mid-Compression Bypass (MCB) bleeds were also modeled. In production F-14s, the MCBs open automatically at elevated angles of attack to increase engine stall margin, but this also decreases thrust by up to 13%.

Rotary Balance Aerodynamic Data - A comprehensive high angle of attack data package, developed from rotary balance wind tunnel tests, was incorporated into the low speed portion of the F-14 aerodynamic database (for 22° wing sweep and Mach Numbers below 0.6). The rotary balance data covers the full angle of attack range from 0° to 90° and greatly enhances the modeling of the forces and moments acting the aircraft while subjected to a rotational flow field (References 7 and 8). A schematic of the F-14 high angle of attack simulation aerodynamic database including the new rotary balance data is shown in Fig. 5.

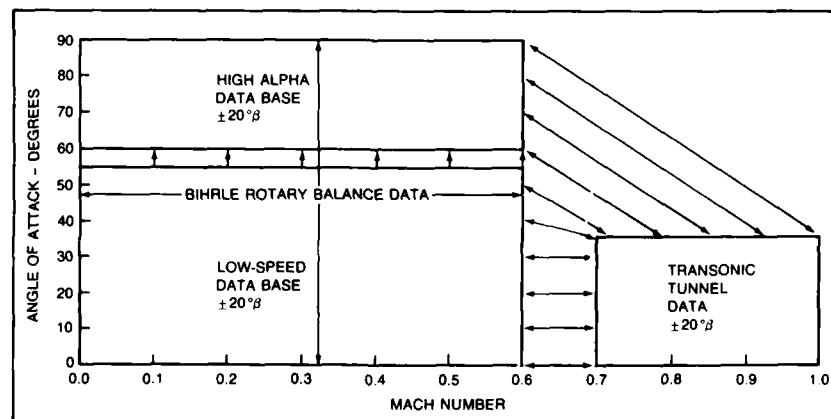

Fig. 5 F-14A High Angle-of-Attack Simulation Data Base

Empirically Derived Aerodynamic Database Adjustments - Modifications to the low speed aerodynamic coefficients were also empirically derived from flight data obtained during the Asymmetric Thrust/Stores test program. Wind tunnel data had originally been enhanced by the results of small perturbation parameter identification, but the existing database still exhibited lack of correlation to flight data for certain angle of attack/control input combinations. This was due in part to the inability of parameter identification techniques to extract accurate coefficient data from departure maneuvers which generated such extreme angle of attack and sideslip excursions. As a result, an existing six degree of freedom (6-DOF) non-realtime digital simulation program was modified to derive the necessary aerodynamic database modifications to improve correlation by making maximum use of the existing flight data.

As shown in Fig. 6, the 6-DOF off-line simulation software uses flight measured control surface deflections as forcing functions to the same aerodynamic model used on the realtime, piloted simulator. Simulation results are overplotted against flight data to show maneuver time history correlation between flight measured and simulator calculated aircraft dynamics. The maneuver time history comparisons are used to determine how the simulator database should be adjusted to improve the simulation-to-flight matching. As outlined in Fig. 7, this process is repeated until an acceptable match is obtained. The final database adjustments are then incorporated directly into the real time piloted simulator.

For the purposes of the Low Altitude Asymmetric Thrust Program, the 6-DOF simulation code was altered to allow the simulation of only a single degree of freedom of aircraft motion at a time. Flight measured aircraft data was substituted into the equations for the remaining five degrees of freedom so all functional dependencies and coupling terms were based totally on flight data. This permitted specific aerodynamic coefficients to be isolated as to their effect on the fidelity of the simulation-to-flight data matching. The aerodynamic coefficients were broken down (in plotted time history format) into their component parts to analyze the contribution of each component to the total coefficient throughout a maneuver. This allowed specific aerodynamic components to be adjusted interactively with a direct measure of how any given adjustment effected the overall simulation fidelity. Figure 8 shows an example of the type of simulation-to-flight correlation improvement generated using this 1-DOF iterative matching process. Using this technique, modifications were derived for yaw axis ($C_{n_{\delta a}}, C_{n_{\delta r}}$) and roll axis ($C_{l_{\delta a}}, C_{l_{\delta a}}, C_{l_{\delta p}}, C_{l_r}$) aerodynamic coefficients.

Once the F-14 simulation model improvements had been developed in the non-real time off-line simulation, the math model and database updates were incorporated into the FTFBFS.

Simulation Fidelity Issues

To assure that the F-14 model updates provided sufficient simulation fidelity to proceed with the low altitude test program, selected departure maneuvers from the Asymmetric Thrust/Stores flight program were repeated on the FTFBFS. The simulation results were then correlated with the corresponding flight results to assess the level of fidelity improvement achieved. Correlation plots were generated for each of the primary departure parameters and, in general, indicated that the level of simulation-to-flight

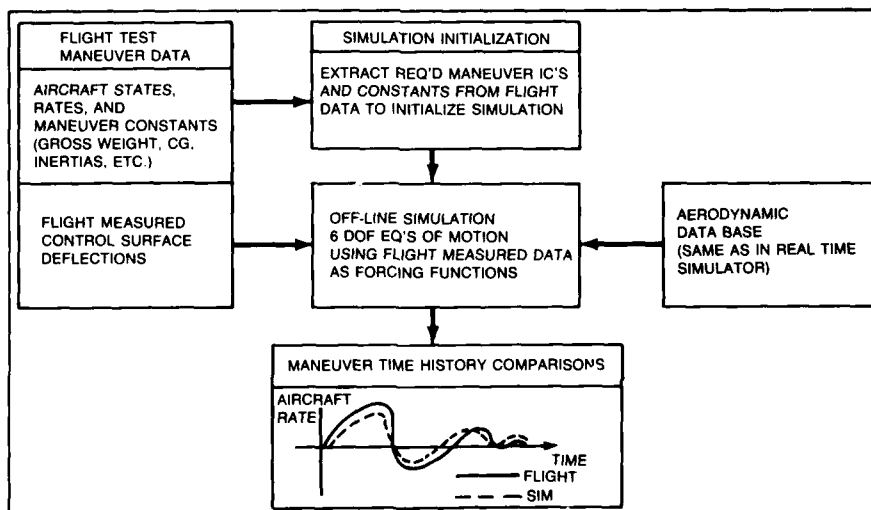

Fig. 6 Off-Line Six DOF Simulation-to-Flight Time History Model Matching Procedure

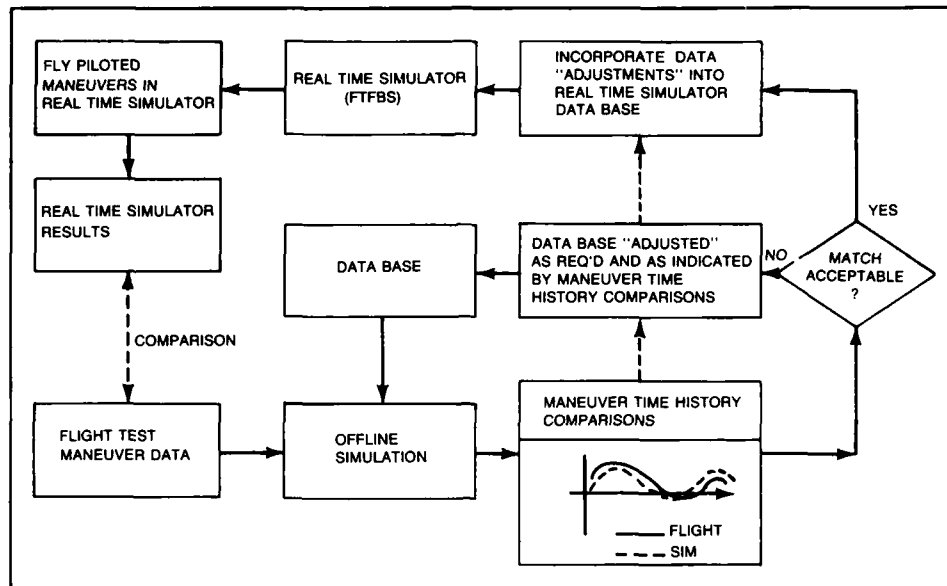

Fig. 7 Iterative Simulation Database Fidelity Improvement Process

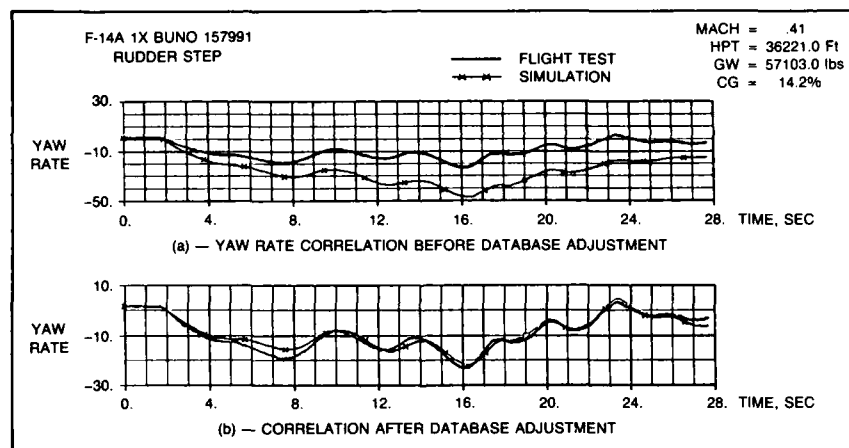

Fig. 8 Example of One DOF Simulation-to-Flight Time History Correlation Improvement

fidelity had been significantly improved. Figure 9 shows the before and after update correlation plots for one of the principal F-14 high angle of attack departure parameters, maximum yaw rate. The closest correlation is evident in the symmetric power maneuvers and indicates the enhancements provided by the updated aerodynamic modeling. The asymmetric thrust maneuvers performed with the new engine model also show correlation improvement but remain somewhat more conservative with respect to the aircraft results, as desired.

While the F-14 model updates definitely improved the simulation-to-flight data correlation, it was still necessary to assess the adequacy of the simulation fidelity for low altitude testing. The dynamic nature of the high angle of attack departure/spin maneuvers made application of a rigid set of quantitative simulation fidelity criteria extremely impractical, however. With the large angular excursions of these maneuvers, the timing of the pilot's control inputs are crucial to maneuver repeatability since only slight differences in control phasing can cause significant variations in certain aircraft parameters. Therefore, rather than apply a set of inflexible and unworkable fidelity criteria, a more practical philosophy was adopted. The acceptability of the simulation fidelity was based on experience, familiarity with the aircraft, and best engineering judgement. This approach required close coordination and concurrence between test management, engineering and flight crews. The simulation was

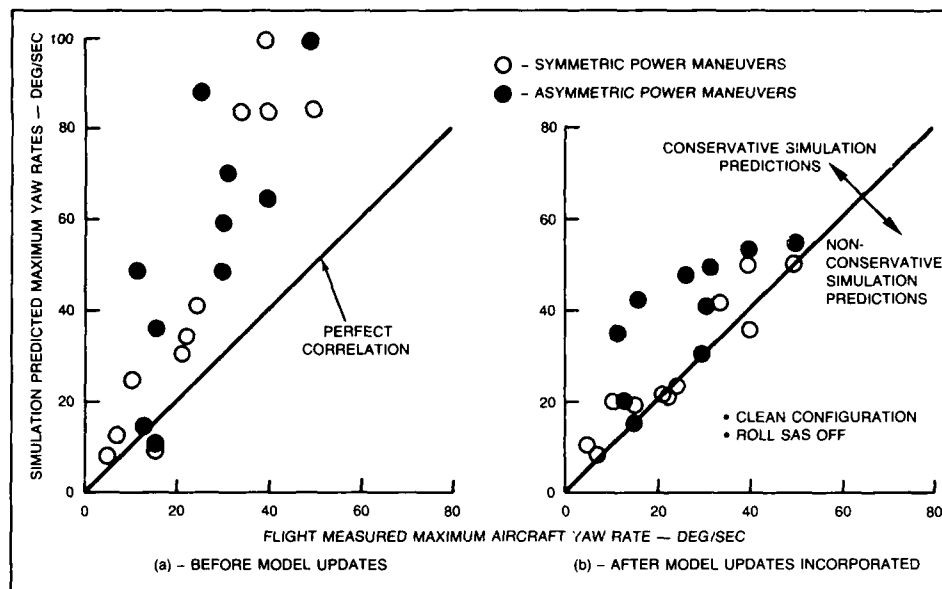

Fig. 9 Piloted Simulation Correlation Results for Selected F-14A Departure Maneuvers

deemed acceptable as long as it provided a "close but conservative" representation of the aircraft's departure and recovery characteristics. To insure adequate flight safety, the simulator had to remain slightly more critical than the aircraft to guard against an unexpectedly severe departure. The level of simulation fidelity provided by the F-14 model updates was therefore judged to be acceptable for proceeding with the flight testing at low altitudes.

Simulation-Flight Test Philosophy

To accomplish the LAAT program test objectives in the safest, most effective manner, a general "simulate-fly-simulate" test philosophy was applied on a flight-by-flight as well as on an overall program basis. For individual flights, the test maneuvers would first be rehearsed on the simulator, then performed in flight and -- if necessary -- reflight on the simulator following the flight to investigate any simulation-to-flight discrepancies. On an overall program basis, the simulator would be used for initial flight test planning and, after completion of the flight program, to demonstrate flight characteristics at any conditions deemed too hazardous to be safely evaluated in the aircraft.

The initial portion of the simulation and flight test program was conducted in the baseline "clean" configuration (no external stores). This represents the least critical configuration from a stability and control standpoint (i.e., maximum directional stability) and provided a safer starting point for "feeling out" the low altitude departure and recovery characteristics. The rationale for the test program was to explore the low altitude asymmetric thrust flight characteristics in the clean aircraft configuration and then perform a limited "spot check" in a critical store configuration to determine store effects, if any. The critical store configuration chosen for the F-14 high angle of attack testing is referred to as the "2 x 4" store loading (i.e., two each of four different store types). This configuration consists of two forward fuselage mounted AIM-54 missiles, two each of wing glove pylon-mounted AIM-7 and AIM-9 missiles, and two nacelle mounted fuel tanks. The "2 x 4" loading was chosen for testing because it represents the most critical fleet store configuration combining the destabilizing effects of wing, fuselage, and nacelle mounted stores.

Simulation Test Planning & On-Site Support

The first phase of the LAAT program involved an extensive piloted simulation program utilizing the newly operational FTFBS to plan flight test demonstration maneuvers and to develop safe low altitude departure maneuver techniques and criteria. The prime objective of the simulation effort was to quantify the effects of asymmetric thrust on the departure and recovery characteristics as functions of altitude, airspeed, and angle of attack. Since engine stalls frequently occur as a result of the large angle of attack and sideslip excursions in these maneuvers, various combinations of asymmetric thrust and pro-spin flight control inputs were also evaluated to determine the contribution of each to the total aircraft response. To quantify these components, a test matrix consisting of the following maneuvers was performed at each angle of attack/Mach Number/altitude test point:

Symmetric Power

Lateral Step
Rudder Step
Cross Control Step

Asymmetric Power

Afterburner to Idle Power Throttle Chop
Lateral Step + Throttle Chop
Rudder Step + Throttle Chop
Cross Control + Throttle Chop

Once quantified, the simulation test results were used to define the most critical angle of attack/yaw rate/asymmetric thrust combinations that could be safely demonstrated at low altitudes.

In performing and analyzing this test matrix on the FTFBS, the advantage of utilizing a simulation facility designed specifically for flight test support became evident in a true operational sense. Due to time constraints imposed on the test planning phase of the program by the test aircraft's schedule and by the near-term transition of the test team across country to the NASA Dryden-Edwards Air Force Base flight test facility (discussed below), it became crucial that the test matrix be completed as quickly as possible before the test team left Calverton. The functionality designed into the FTFBS and its maneuver analysis capabilities permitted high simulator utilization rates to be achieved so that a total test matrix of 896 maneuvers was flown and reduced after only 8 piloted simulation sessions conducted in 10 days calendar time.

Following completion of the test planning phase on the FTFBS, the site of the test operations moved from Calverton to the NASA Dryden Flight Research Facility (DFRF) at Edwards Air Force Base, CA. All LAAT program test flights were conducted from the NASA facility by a joint Grumman/Navy/NASA test team. NASA DFRF was selected as the test site due to the availability at Edwards of the Rogers Day Lake bed. In the event of a dual engine stall at low altitude, the dry lake bed was required so that a flameout approach and deadstick landing could be safely performed.

The test aircraft utilized for the flight program was F-14A No. 1X (BUNO 157991), a high angle of attack test bed (see Fig. 10) equipped with an emergency spin recovery system that includes:

- Mortar-deployed 26ft. (8 m) spin chute mounted on the aircraft aft fuselage
- Two canard surfaces, mounted flush to the forward fuselage ahead of the cockpit section, which extend to eliminate any asymmetric vortex shedding from forebody at high angles of attack
- Emergency lateral flight control system authority to provide additional aerodynamic recovery control.

Spin tunnel results have shown that a combination of any two of the three components is theoretically capable of recovering an F-14 from a fully-developed flat spin. In addition, F-14 No. 1X contains a battery powered Emergency Power Unit to supply hydraulic and electrical power to critical aircraft systems should a dual engine flameout occur in flight.

At NASA Dryden, the utilization of simulation for support of high risk flight testing is a mandatory safety of flight component. Three simulation prerequisites were formally established for the LAAT program to maintain flight safety:

- Preflight simulation of all test maneuvers was required prior to flight. No maneuver was to be performed in flight without first being performed on the simulator



Fig. 10 F-14A 1X High Angle of Attack Test Aircraft With Extended Canards

- Critical departure and recovery parameter results from the simulation were to be noted on the pilot and test engineers' flight cards so that simulation-to-flight test fidelity could be tracked in real time
- The simulator must provide acceptable correlation with the flight test results at all times and remain conservative with respect to the aircraft.

NASA provided access to their piloted F-14 simulation facility throughout the test program. It was first necessary, however, to incorporate into the Dryden simulator the F-14 fidelity improvements developed at Calverton and to validate them against the FTFS results to assure that identical models were being used. In essence, this validation process required matching output from two different simulation facilities located at opposite ends of the country. The validation process was made more difficult by hardware and software differences between the two facilities such as in the types of digital simulation computers used (i.e., 32 bit versus 16 bit accuracy), in the numerical integration routines and frame rates used, etc. Despite these difficulties, the validation process was completed and served its intended purpose since several minor modeling problems were discovered and corrected prior to the simulator's being used for flight support activities.

The first flight support activity on the Dryden simulator involved the determination of which of the several spin areas at Edwards would be most suitable for the F-14 LAAT program. Operated in conjunction with an x-y terrain plotting board, the simulator was flown from an assumed worst case scenario of a dual engine flameout occurring under 10,000 ft (3030 m) in which the aircraft recovers from a high angle of attack departure maneuver headed 180° away from the dry lakebed runway. A flameout approach was then attempted from each of the spin areas to determine the one providing the largest safety margin for a deadstick landing. In addition to aiding in the selection of a suitable spin area, this exercise also helped to define the ground-based telemetry and video tracking requirements for the flight program, providing another simulation derived test benefit.

Simulation Verification Flight Testing

The LAAT program's first test flights at Dryden were conducted in the clean aircraft configuration. The maneuvers in the initial phase of the testing were flown specifically to confirm the fidelity of the simulator's aerodynamic and thrust models. As such, a majority of the maneuvers involved pure flight control or asymmetric thrust induced departures at high altitudes. Symmetric power recovery characteristics were also evaluated during these initial flights. The tests provided a baseline verification that the simulator was accurately representing the F-14's departure characteristics at high altitudes.

The tests to evaluate asymmetric thrust recovery characteristics at somewhat lower altitudes were conducted next in the flight program. Accurately defining the aircraft's recovery characteristics with thrust asymmetries present was a prerequisite for determining the limits to which further low altitude tests could be safely flown. Asymmetric thrust recovery boundary plots for the F-14 had been developed on the simulator during the test planning phase and were found to be functions of yaw rate, altitude, and the level of thrust asymmetry present. A typical recovery boundary plot is shown in Fig. 11 and includes the results from the corresponding LAAT flight test maneuvers. Several inflight asymmetric thrust recoveries up to a maximum of 50° deg/sec yaw rate were performed during this phase of the test program to verify the simulation derived boundaries. Recovery boundaries were also established at lower altitudes and generally substantiated the simulator-derived flight safety criteria established prior to the flight program.

Departure characteristics due to asymmetric thrust alone were next evaluated by performing maximum afterburner throttle chops during level wind-up turns at progressively lower altitudes. Angle of attack at the throttle chop was varied from 20° to full aft stick (approximately 35° true angle of attack) and at altitudes down to a minimum of 10,000 ft MSL - about 7,700 ft (2330 m) AGL for Edwards Air Force Base. A special test technique developed on the simulator and used during these maneuvers was to select engine MCBs closed in order to increase the level of thrust asymmetry present at any given altitude. The test aircraft, unlike production F-14s, has cockpit switches which enable the test pilot to manually control MCB operation. The simulation, which included MCB modeling, had shown that by manually selecting MCBs closed at high angles of attack (where normally they are open in a production aircraft to increase engine stall margin), higher thrust levels were possible in the test aircraft. This provided increased thrust asymmetries in the test aircraft that were the equivalent to approximately 5,000 ft (1515 m) lower in altitude for a production F-14. This technique was used extensively to "extrapolate" lower altitude production aircraft thrust asymmetry effects from test aircraft data at higher altitudes, thereby enhancing flight safety.

Overall, the flight test results showed that asymmetric thrust in and of itself produces a smooth build-up in roll and yaw rates, consistent with the results obtained at higher altitudes and as predicted on the simulator. However, while the simulation and flight results had shown that asymmetric thrust by itself was not a cause of severe F-14 departures, it could nonetheless contribute to a departure if lateral stick was applied to counter the asymmetry-produced roll rate: at high angles of attack, this lateral stick input is pro-spin. Therefore, the effects of control induced departures

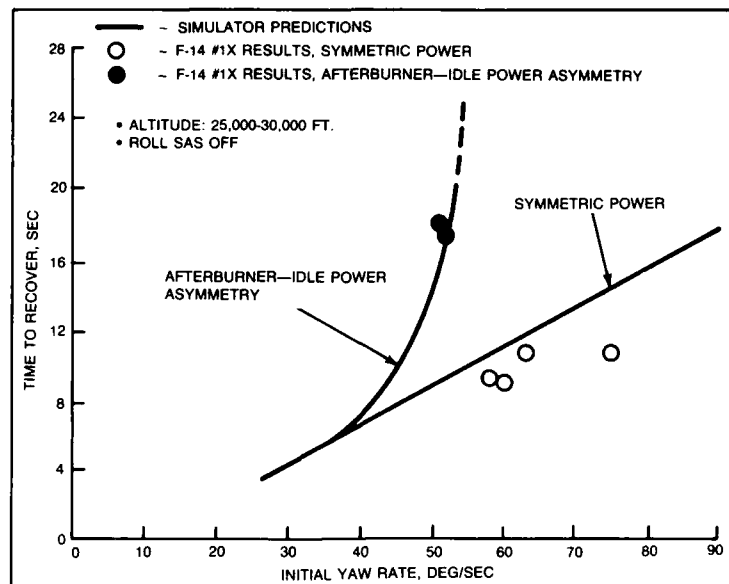

Fig. 11 F-14A Clean Configuration Recovery Boundary

coupled with thrust asymmetry also had to be tested at progressively lower altitudes. The combined effects were evaluated by simultaneously applying a throttle chop with either a lateral, rudder, or cross control input at angles of attack again varying from 20° to 35°. Each maneuver set was repeated at progressively lower altitudes down to a minimum of 15,000 ft (4545 m) MSL. These high risk test maneuvers verified that the simulator was accurately representing the F-14's high angle of attack departure and recovery characteristics at all altitudes in the clean aircraft configuration.

Critical Store Configuration Testing

Following the completion of the clean configuration flight tests, the simulation model was re-configured with a database containing aerodynamic and mass/inertia data for the 2 x 4 store loading. A test matrix consisting of selected maneuvers from the clean test envelope was flown on the simulator to plan the 2 x 4 verification flight tests. Several of the 2 x 4 simulation maneuvers, however, exhibited forward stick recovery trends more benign than in the clean configuration. Since high altitude test data obtained during the Asymmetric Thrust/Stores program had shown recoveries in the 2 x 4 store loading to be more critical, this presented a potential problem to the 2 x 4 test planning because the "close but conservative" simulation fidelity criteria would be violated.

An examination of the 2 x 4 aerodynamic database revealed that the data for yawing moment due to differential stabilizer, $C_{n_{\delta_a}}$, was too adverse at high angles of

attack over a range of stabilizer deflections. As a result, the adverse yaw generated by forward stick differential stabilizer settings during the application of recovery controls in the simulator was strong enough to significantly effect the predicted 2 x 4 recovery characteristics. Since acceptable correlation between simulator and aircraft adverse yaw characteristics had been obtained during the clean configuration testing, an interim solution of substituting the clean $C_{n_{\delta_a}}$ data into the 2 x 4 model

was decided upon. This interim solution produced more representative modeling of the 2 x 4 recovery characteristics and restored an appropriate level of conservatism to the 2 x 4 simulation to permit completion of the test planning of the 2 x 4 demonstration maneuvers.

The goals of the 2 x 4 flight test program were to verify in flight the simulator predicted departure/recovery characteristics and to spot check the clean configuration test envelope to determine the effects of external stores. The first maneuvers performed in flight were asymmetric thrust recoveries to determine any degradation in recovery capability due to stores. Recoveries from yaw rates of 30, 40, and 50°/sec were demonstrated at altitudes between 25,000 and 30,000 ft. Figure 12 shows the degree of correlation achieved between the flight results and the simulator-derived recovery boundaries for this altitude range. A sequence of throttle chop maneuvers at varying angles of attack was then performed at decreasing altitudes. However, simulation results indicated that for flight safety reasons a minimum altitude restriction of 15,000 ft should be imposed for all 2 x 4 maneuvers flown above 30 degrees angle of attack.

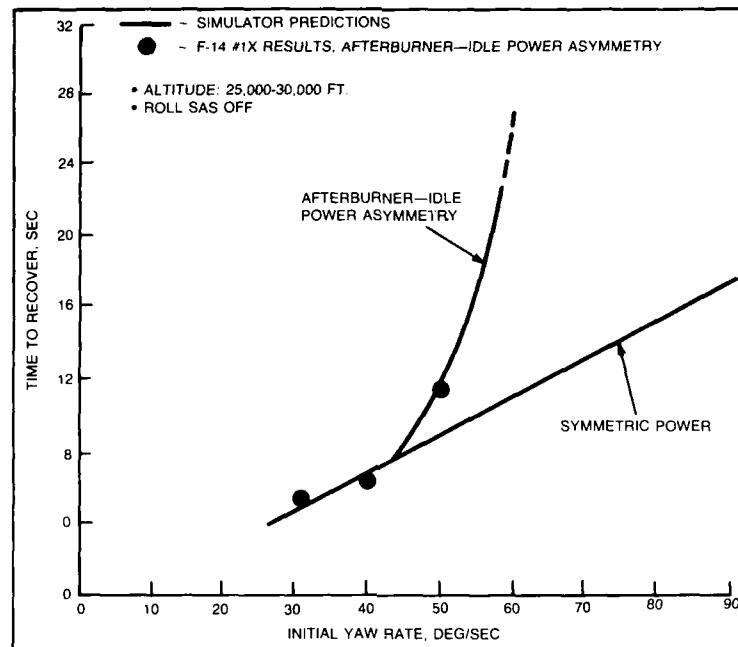

Fig. 12 F-14A 2x4 Configuration Recovery Boundary

The 2 x 4 configuration maneuvers involving lateral stick, rudder, and cross control inputs combined with throttle chops were likewise limited to a 15,000 ft minimum to maintain a proper margin of flight safety. In general, the 2 x 4 flight results showed excellent agreement with the simulation predictions and provided the same levels of confidence in the 2 x 4 simulation as obtained with the clean model.

SIMULATION SUPPORT OF CRITICAL PROGRAM ENDPOINT

It is appropriate that of the many maneuvers performed during the low Altitude Asymmetric Thrust testing, the one maneuver best exemplifying piloted simulation support for the F-14 high angle of attack flight testing also happens to be one of the program's critical low altitude demonstration endpoints. This critical endpoint, part of the clean configuration testing, was a throttle chop performed during a wind-up turn to full aft stick at 10,000 ft altitude. This maneuver was the lowest altitude test point accomplished during the program and achieved maximum flight conditions of over 60° angle of attack and 48°/sec yaw rate with full afterburner/idle power thrust asymmetry. Piloted simulation played an important role in allowing this hazardous maneuver to be safely performed in flight.

Piloted simulation first influenced this maneuver during the program test planning stages on the FTFBS when the maneuver techniques used for performing safe low altitude throttle chops were initially developed. The maneuver techniques involved performing a wind-up turn at level altitude and then chopping the throttle on the topside engine when the target angle of attack was attained. By retarding the topside engine during a wind-up turn (i.e., right throttle chop during a wind-up turn to the left), the aircraft would respond by rolling into the retarded engine to a more upright, wings level flight condition. At low altitudes, rolling initially to a wings level attitude provided an extra margin of safety and helped to keep the aircraft near the selected test altitude. The use of the selecting the engine MCBs closed to increase the effective thrust asymmetry was also a part of the simulation developed maneuver technique, as was discussed previously.

Once the flight test program started at Dryden, the use of simulator became even more significant for the safe execution of this maneuver in flight. Early simulation results had shown that the minimum safe test altitude to allow adequate altitude for aircraft recovery and a successful flameout approach was 10,000 ft MSL. However, during the maneuver rehearsals on the Dryden simulator prior to flight, several additional engine chop maneuvers were performed at this altitude and indicated that significant variations in both the time and altitude required for recovery might result depending on the timing of the pilot's recovery control inputs. As a direct result of these simulation predictions, it was decided to provide extra recovery capability for the low altitude asymmetric thrust maneuvers by engaging the emergency lateral flight control authority mode prior to performing the throttle chop. As it turned out, even

with the increased lateral control authority, the aircraft's recovery against the thrust asymmetry took longer in flight than predicted in the simulator. While the aircraft was successfully recovered at approximately 5,000 ft (1515 m) AGL, a discrepancy had arisen between the simulator and flight results. This put a temporary halt to the flight program and initiated a simulation study effort to determine the cause of the discrepancy.

A satellite telemetry link had been established between NASA Dryden and Calverton to relay aircraft test data between the two facilities in real-time. As a result, engineers at Calverton were able to process the data immediately after the flight and began to study the maneuver on the FTFBS shortly thereafter. The effort at Calverton was crucial to the quick resumption of the flight program since availability of the Dryden simulator was limited on a time-share basis to a maximum of 2 hrs per day. With the entire test team on-site at Dryden, the one man operational capability of the FTFBS became important because it allowed one engineer at Calverton, working in parallel with the test team at Dryden, to analyze the simulator-flight discrepancy using the same piloted simulation model as available at the test site. Extensive analysis on the FTFBS revealed that the severity of the aircraft's response was due to the excessive amount of airspeed lost during the maneuver because of the test aircraft's unexpected nose high entry attitude. This reduced recovery control effectiveness, thereby slowing the recovery. The airspeed lost during the maneuver was found on the simulator to be a direct function of the aircraft's pitch attitude at the time of the throttle chop. The simulated throttle chops during flight rehearsal had all been performed during near-level wind-up turns and explained why the severity of flight results had not been predicted on the simulator prior to flight. The FTFBS analysis indicated that if the phasing of the controls and maneuver entry conditions were closely matched with those from flight, the aircraft's response could be duplicated on the simulator and good simulation-to-flight correlation was produced. The apparent discrepancy between simulation and flight results had therefore been due to a difference in maneuver entry conditions, not to a simulation modeling problem. The results of the FTFBS analysis were relayed to the test team at Dryden who concurred with the analysis results and the flight program was allowed to continue without any further delays. This test maneuver had shown the effect of asymmetric thrust becoming more severe with decreasing airspeed and altitude, but also clearly demonstrated the value of piloted simulation used integrally to support high risk flight testing in the F-14.

CONCLUSIONS

The results from the recent F-14 high angle of attack flight test programs have shown that piloted simulation support is a necessary means of enhancing flight test safety, productivity, and data analysis. This was particularly evident for the departure testing at low altitudes and demonstrates that the higher the risk in the flight program the more effective the use of ground-based, piloted simulation becomes to achieving the program's test objectives. Simulation allows more detailed understanding of the flight test results by "filling in the gaps" which would be prohibitive in the test aircraft from both a cost and a safety standpoint. When suitably designed for the task and integrated into the overall program test approach, a piloted simulation capability is an invaluable support tool in the flight testing environment.

REFERENCES

1. Nguyen, Luat T.; Gilbert, William P.; Gera, Joseph; Iliff, Kenneth W.; and Enevoldson, Einar K.: Application of High- α Control Concepts to a Variable Sweep Fighter Airplane. Presented at the AIAA Atmospheric Flight Mechanics Conference, Danvers, Mass., Aug. 11-13, 1980.
2. Gera, J.; Wilson, R.J.; Enevoldson, E. K.; and Nguyen, L. T.: Flight Test Experience with High- α Control System Techniques on the F-14 Airplane. Presented at the AIAA/SETP/SFTE/SAE/TTEA/IEE 1st Flight Testing Conference, Las Vegas, Nev., Nov. 11-13, 1981.
3. Smith, Harriet J.; Enevoldson, Einar: The Application of a Six-Degree-of-Freedom Piloted Simulation in Support of the F-14 Flight Research Program. Presented at SES/SFTF Symposium on Simulation-Aircraft Test and Evaluation, Patuxent River, Maryland, March 16-17, 1982.
4. Schaefer, F.; F-14 Asymmetric Thrust/Stores Final Report, Grumman Report No. FAD-303A-1X-3.22, January 7, 1982.
5. Schaefer, Frederick W.; F-14 High Angle of Attack Investigation with Asymmetric Thrust and External Stores. Presented by SFTE 13th Annual Symposium, New York, N.Y., September 19-22, 1982.
6. Conigliaro, P.; F-14A Low Altitude Asymmetric Thrust Program Final Report, Grumman Report No. FAD-303A-1X-3.25, March 1, 1985.
7. Barnhart, B.; F-14 Rotary Balance Tests for an Angle-of-Attack Range of 0° to 90°, Report No. NADC-81293-60, January, 1983.
8. Bihrie, W. Jr. and Barnhart, B., Spin Prediction Techniques, Journal of Aircraft, Vol. 20, Feb. 1983. pp. 97-101.

THE USE OF AERITALIA FLIGHT SIMULATOR FOR THE DEVELOPMENT
OF THE AM-X WEAPON SYSTEM

by

Armando ARMANDO and Maurizio SPINONI
Flight Simulation Center
Aeritalia - Combat Aircraft Group
Corso Marche 41 - 10146 TORINO (ITALY)

Introduction

For the first time in Italy a flight simulator has been used since the very beginning in the development of a new tactical fighter not only for handling assessments, like in some former programmes as VAK 191, G222 and TORNADO, but also for developing the weapon system as a whole, optimizing the pilot station, studying the most suitable operational procedures and defining the formats and symbologies on the electronic displays. At the moment, during the prototypes flight test activity the simulator is being intensively used to investigate many problem areas arising from flight tests. In the near future it will help the development of new advanced versions of the AM-X weapon system.

The AM-X programme

AM-X is a single-seat close interdiction and CAS aircraft. It has been developed by Aeritalia and Aermacchi in collaboration with Brazilian Embraer. Aeritalia retain prime responsibility in the whole project. AM-X has been developed specifically for the ground attack role and is capable of operating at low altitude in an hostile environment. It is powered by a single Rolls-Royce "Spey" Mk 807 turbofan rated at 5000 kgp at sea level. Redundancy and modular design concepts have been applied to allow failure and damage tolerance and will facilitate future configurational changes. Armament includes up to 3500 kg of external payload on 5 hardpoints, two AIM9-L at wing tips and one M61 20-mm cannon in the forward fuselage. First prototype flew in May 1984, and nowadays flight test programme is under way with four aircraft with delivery to operational units expected in 1988.

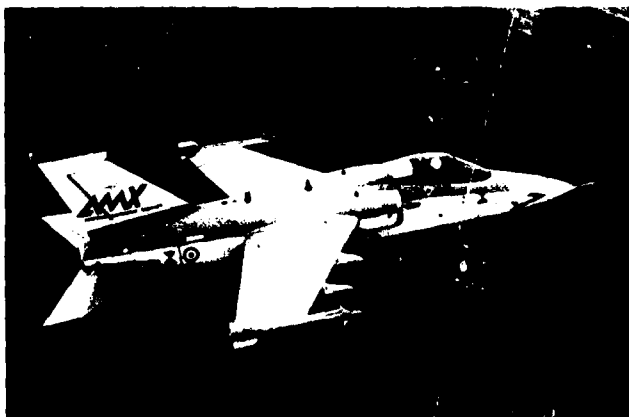

- Fig. 1 -

The AM-X flight simulator

When the AM-X programme started in 1980, it was decided to improve the existing simulation facilities to set up a Flight Simulator layout to be used as an engineering tool through all the phases of AM-X weapon system development, keeping costs at reasonable level. An important basic assumption was made, i.e. an engineering simulator does not need to create the illusion of flight, but only needs to represent flight and operational parameters, or data, in such a way that well experienced test pilots can process them as they process real flight cues.

To establish theoretically the principles of these similarity reductions would be definitely a very hard enterprise. Practically, it was found that a clever cooperation between flight and simulation experienced people can easily lead, after a few trials, to very acceptable task-oriented solutions.

To define the simulator characteristics a set of consolidated requirements was determined. Flight Simulation had to cover the following areas:

- i) Ground and general handling simulation, with primary controls and with every possible controls degradation.
- ii) Handling simulation with manual flight controls, possibly limited to some significant points in the flight envelope.
- iii) Simulation of flight with failed engine.
- iv) Human engineering assessment (cockpit geometry and layout, Displays and Controls, etc.).
- v) Operational mission simulation, including phases like air-to-ground attacks, air-to-air self-defence combat, formation flight, oriented to the harmonization of the AM-X system as a whole.

As a first result of the review of these requirements, it was decided that, for the type of simulation required, the most important physical cue to be supplied to the pilot was visual cue. The visual system, in turn, considering the battlefield ground attack role of the AM-X and its air-to-air self-defence manoeuvring capability, had to be something capable of displaying targets (either ground or air) in the widest possible space around the simulator cockpit, in terms of azimuth and elevation.

Rejected as too complex for the programme purposes the hypothesis of pentagonal CRTs, a dome seemed to be the only practicable possibility. But again, to fill at least the front hemisphere with a full dynamic landscape representation (for air-to-ground attack simulation) and display anywhere in the dome an air opponent seemed to be very hard, on both technical and economical standpoints.

It was then decided to use a sky-earth projector to supply pilot peripheral vision with some attitude cues and an area-of-interest slewable projector to display either air or ground targets. To obtain an acceptable presentation of ground target area, this should have been a colour projector with a field angle of about 60 degrees. Such an arrangement would allow to perform attacks against off-set targets, pop-up attacks and air-to-air manoeuvring, but it was not compatible with a motion base unless using a very small dome and introducing engineering complications not compatible with the overall programme philosophy. In addition, two important considerations were made about the motion system:

- 1) In the simulation of a combat aircraft with conventional handling qualities a motion system can only supply a small contribution, and in addition limited to few phases of flight.
- 2) If not perfectly working, the motion system can be misleading. In fact, a g-seat could be more useful, but not replace the motion system since it supplies different types of cues relative to different phases of flight.

As a result of all these factors the fixed cockpit in a dome was considered the optimal solution.

The requirement of human engineering assessment is a different matter in terms of similarity. To achieve an acceptable degree of adequacy, it is important to reproduce with high fidelity tactile sensations, colours, lighting levels, shapes etc. together with supplying for each simulated item the proper environment of use.

Late experiences showed that some compromises in similarity which are accepted on the simulator could result unacceptable in the real mission. On this subject even experienced pilots could be driven to misleading judgements with a not perfect or not adequately in stalled mock-up.

For all these reasons, the specified cockpit assessment through flight simulation required a fully representative cockpit, in which those functions subject of investigation had to be fully activated.

- Fig. 2 -

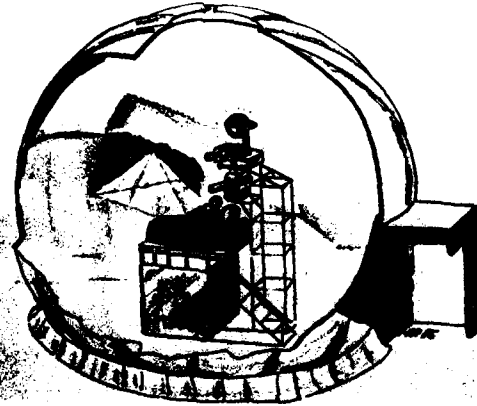

In the AM-X primary flight control system the control forces versus stick and pedals position do not change in the whole flight envelope even in case of full electrical or single hydraulic failure (the aircraft response, of course, does, depending on the failure). Only in case of double hydraulic failure, which includes the engine flame-out case, a direct mechanical connection between stick, elevator and aileron generates control forces that are function of the hinge moments. So, it was decided not to use a CLS. The control forces on the simulator have been reproduced through bungies and friction devices. The manual mode has been only simulated at optimum glide speed and flame-out approach speed with different sets of bungies and frictions.

At the end, AM-X Flight Simulator arrangement resulted as follows:

-) Fully instrumented cockpit in a dome.
-) Sky-earth projector.
-) Visual generating system (terrain model, graphic computer).
-) Real time simulation computer.
-) Control and monitoring station.

Following a brief description of the various components is given:

-) The dome is of the inflatable type with a 10 meters diameter.
-) The two axis sky-earth projector is a very simple device, consisting of a practically lightpoint source and a gimbaled transparent plastic sphere painted in two continuous colours. It provides pilot with pitch and roll cues with no angular limitations.

- Fig. 3 -

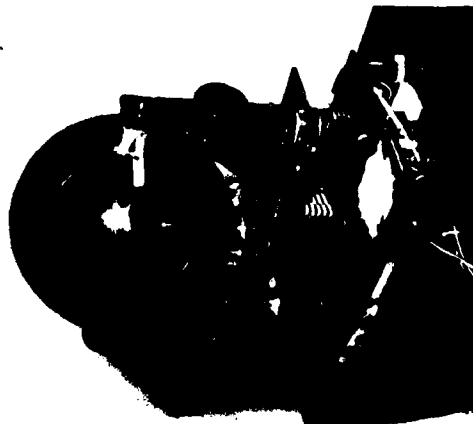

the lack of yaw is overcome by the uniformity of sky and earth representation. It can be offset from the center of the dome in x and y provided a similar offset is given to the lamp inside the sphere, still keeping correct rotations around pilot eye.

-) The area-of-interest slewable projector consists of a slewable optical system fitted downstream a General Electric light valve projector. It was decided to design and manufacture this device in Aeritalia because already developed systems were either monochrome or with small field angle.

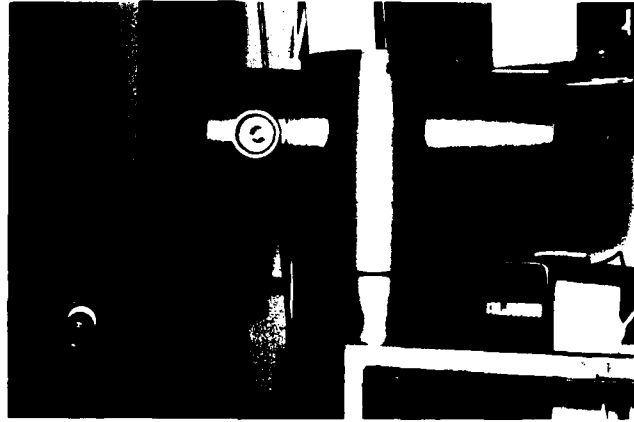

- Fig. 4 -

It is two axis (azimuth and elevation) system, so it is subject to the gymbal lock phenomenon. Practically, this disadvantage proved irrelevant, due to the extremely good dynamic performances of this device and to the fact that the singular condition occurs only transitionally. The field angle is more than 60 degrees, and light power absorption less than 25%.

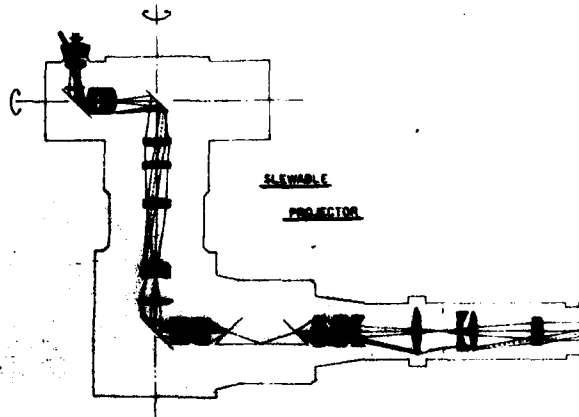

- Fig. 5 -

-) The cockpit, installed with the design eye position in the centre of the dome is equipped and instrumented to the aircraft standard as far as simulation is concerned.

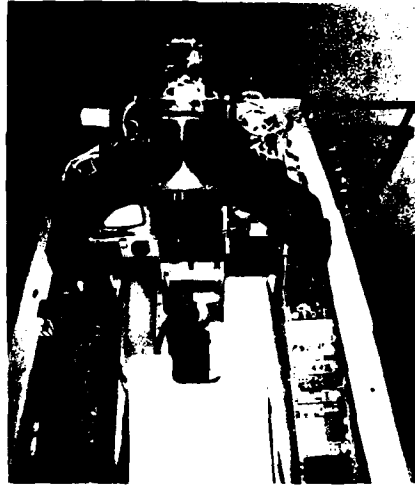

- Fig. 6 -

A home-built HUD interchangeable with the real one has been used to develop HUD symbologies.

-) A terrain model moving belt, which incorporates some improvements developed in Aeritalia is still very useful for some applications in spite of its age and mechanical limitations.
-) The simulator control room is shown in fig. 7.



- Fig. 7 -

-) The real time interface processor is also fitted with MIL-1553B bus controller simulation. This allows real aircraft avionics to be installed and used in the simulator.

-) An Evans and Sutherland MPS colour graphic computer is used for graphic purposes like generation of synthetic runway, target aircraft and HUD symbology.

The simulation software utilize the Quaternion rates integration algorithym, which, as known, has the remarkable advantage of avoiding the gimbal lock drawback, to which is subject the Euler angles derivatives integration method, accepting the discontinuity of ψ and ϕ when the X-axis passes through the vertical. A loop is plotted in fig. 8.

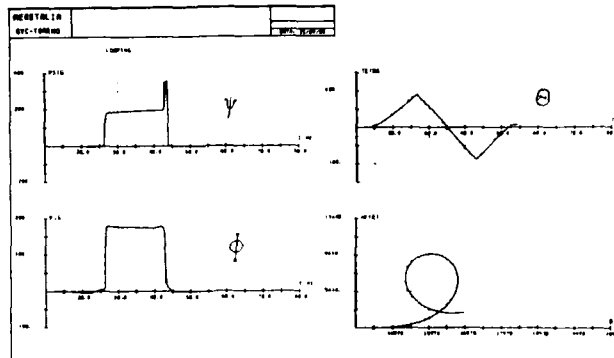

- Fig. 8 -

Using the described facility it was possible to perform several simulation activities.

Flight Mechanics and Flight Controls Simulation

This activity, which is the most usual for an engineering simulator and even the most significant, involved all the investigation of handling qualities in the whole flight envelope, aimed to the optimization of the control laws.

Some critical areas required special attention and several trials.

It was for example the case of nose wheel steer gearing, of transition into and from ground effect during landing and take-off, of crosswind landing, of transonic stability and rudder/aileron crossfeed.

As an example of this last problem figure 9 shows some significant time histories.

The need for a rudder compensation was due to an unwanted adverse yaw developing during step roll manoeuvres. The two cases show the same task of tracking a fixed ground target initially some 45° off boresight.

It can be noted that the bank activity and the relevant azimuth error are strongly reduced with the rudder compensation. The time-constant for the compensation wash-out was at this stage about 4 sec.

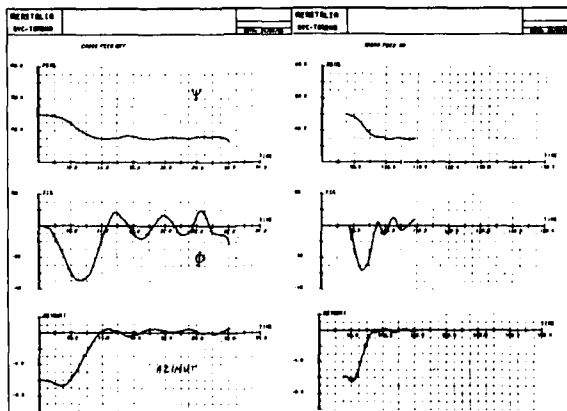

- Fig. 9 -

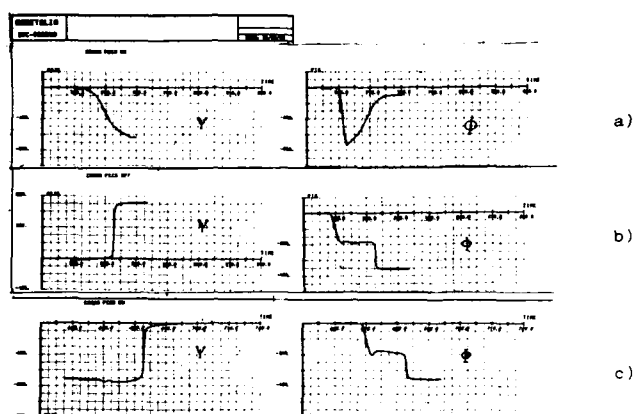

- Fig. 10 -

Fig. 10 shows what happened with such a time-constant in another type of manoeuvre. It consists of a sudden half roll and pull through to obtain a complete heading inversion manoeuvring in the vertical plane. (Fig. 10b).

After the sudden roll the rudder was at its maximum authority deflection and the 4 sec. wash-out caused the A/C to leave the vertical plane, the bank angle to go continuously from 180° to 0° and the final heading to be some 30° from the intended value (Fig. 10a). The optimization of the compensation amount and the time constant led finally to a matching that allows the manoeuvre to be performed in the proper way. (Fig. 10c).

Of course, all possible failures, combinations of failures and failure transients were repeatedly simulated and evaluated. For example, to stay on the same subject, a rudder hard-over due to a spurious cross-feed signal was found to be safety-critical during formation flights: it was another good reason to reduce cross-feed rudder authority. As a result of all this activity the AM-X handling is considered by test pilots very pleasant in all the experimented conditions.

All possible failure conditions have been investigated in real flight without significant problems.

Cockpit development

The cockpit development activities accomplished at flight simulation center involved all the cockpit problems, from outside visibility, which is rather good, to some parallel researches like a voice warning system, but mainly they were oriented to the "hands throttle and stick" concept application and to HUD symbology and moding definition. For the former subject a first anatomic phase was followed by an operational evaluation, aimed to assess the effectiveness of the proposed controls moding. As an example, the chaff and flare activator was found to be not effective on the stick top and was relocated on the left sill, where is easily reachable in any throttle position, but only intentionally.

The N.W.S. mode of operation was completely revised and the EFCS I.C.O. was found to be better located on the left console. The reason for this was that normally an instinctive cut-out allows the pilot to gain full controls authority, whilst in this case the cut out of the EFCS reduces the overall controls authority; it must then be a switch easily operable, but not too easily.

Head-up display symbology

On the subject of HUD formats and symbology definition, it must be said that AM-X is the first aircraft equipped with a completely Italian Head Up Display (HUD). Hence, in order to attain a customized set of formats specifically tailored to the AM-X mission needs, it was decided to develop in Aeritalia the relevant symbology.

A working group with Aeritalia and Italian Air Force test pilots was established, and simulated operational sorties were run on the simulator. The collaborative effort of Aeritalia and military test pilots proved to be very effective, and led to the definition of simple and effective formats, achieving also the highest possible degree of commonality through the various formats.

- Fig. 11 -

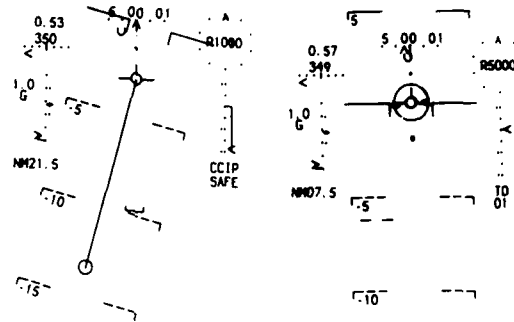

This activity was later on associated with the validation of navigation and weapon delivery concepts.

The use of the area of interest slewable projector in these activities was based not on slaving the visual system to the pilot head movements (which is a better but more complicated solution) but on the simplification assumption that the area of interest can be defined a priori, linking the visual system to a predetermined point on the ground. In this way the pilot look has to follow the area of interest, and not vice versa.

- Fig. 12 -

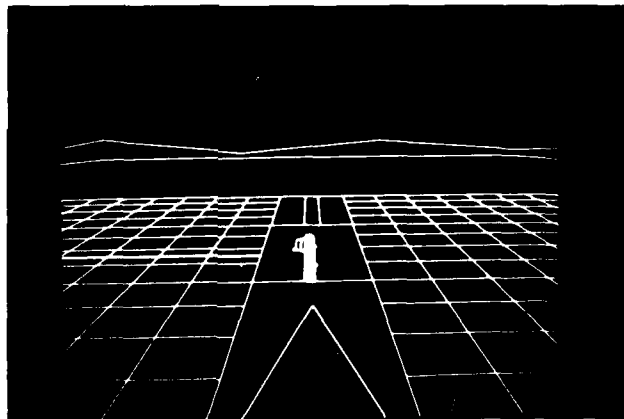

- Simulated Flame-out Patterns

Main objective of this activity has been the identification of the optimum parameters for such a pattern, to verify the pilot/aircraft system behaviour in those conditions and with the degraded flight controls in manual mode, and to help pilots in familiarizing with a circumstance that could happen in case of missed engine relight during in flight relight tests.

Defined the touch-down point at one third of the runway as the area of interest centre for this task, the slewable projector was used to allow the pilot to retain it in view during the execution of the whole manoeuvre. The cockpit flight controls were connected to a bungees and friction system that provides loads corresponding to a manual mode at 180 kts airspeed.

- Fig. 13 -

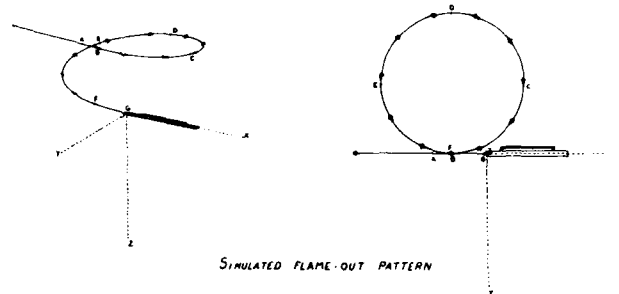

The aircraft was trimmed in the "High Key" position at 7000-8000 ft and with a certain offset in respect to the touch-down point, in order to present the runway at the beginning of the test abeam the aircraft and parallel to it.

As usual, the sky-earth projector provided pitch and roll attitude cues; the ground area projected around the runway resulted large enough to avoid this projected runway appearing like an object floating in the space; the overall effect was like landing on a runway placed in the center of a large, squared island.

To overcome the lack or scarcity of sensations in comparison with the real situation, the HUD continued to be in use, differently from the real flame-out case in which it would be inoperative.

With this arrangement it has been possible to define the required procedures, determining optimized patterns that resulted absolutely correct during the real flight test.



- Fig. 14 -

- Air-to-air Task

The simulation activity of air-to-air tasks has involved up to now in-flight refuelling, formation flight and air-to-air gun attack simulation.

In the beginning, it was considered possible to perform these activities using only the slewable projector and the sky-earth projector. The target image was generated by the graphic computer.

The simulations were started in such a way, but it was soon discovered that the realism of this simulation was not acceptable. In fact, the pilot was subject to an extremely high workload in order to maintain his wingman position and were noticed strong S.I.O. phenomena, that probably can be better defined S.I.O. (Simulator Induced Oscillations). Since the aircraft simulation was verified to be adequate and not misleading, the cause of this phenomenon was ascribed to the lack of physical sensations of movement and to the small amount of information provided by the horizon projector. Moreover it was supposed that during the formation flight the small linear acceleration perception along the three axis could be important when associated to the visual perception of small movements relative to the leader.

To overcome the problem, it was considered to provide the pilot with more information about the external simulated scene. This was obtained installing in the dome another light Valve projector, which projects in front of the aircraft nose the image of the ground derived from the Rediffusion belt model. In this way the simulation acceptability increased, although the added cues being secondary in respect to the primary object of the pilot attention, i.e. the other flying aircraft. After this modification formation flight in the simulator became easy and satisfying, also when the frontal scene is at the limit of the pilot peripheral vision.

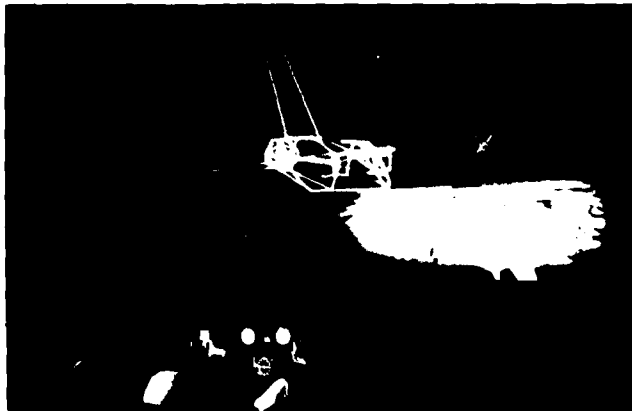

- Fig. 15 -

The frontal visual channel has a FOV of about 35x25 degrees. With this presentation it was possible to perform the scheduled air-to-air task, consisting of the following activities:

Air-to-air fight

Simulation was used to optimize the filtering algorithms used for the air-to-air fight.

When simulation runs were made to determine the values of the time constants in order to obtain a smooth movement of this system during air-to-air combat, with both systems running in constant-by fixed range modes without introducing excessive delays. The activities resulted in the optimization of the algorithms, with a good stability of the system and a good tracking required.

Future studies will involve visual AIM-9L Sidewinder delivery and snag operations.



- Fig. 16 -

In-flight Refuelling

Simulation mainly concerned handling during that particular task. The simulation allowed to identify and correct some latero-directional stability problems supposed in those conditions; some gains adjustments were required in order to obtain a more pleasant response.

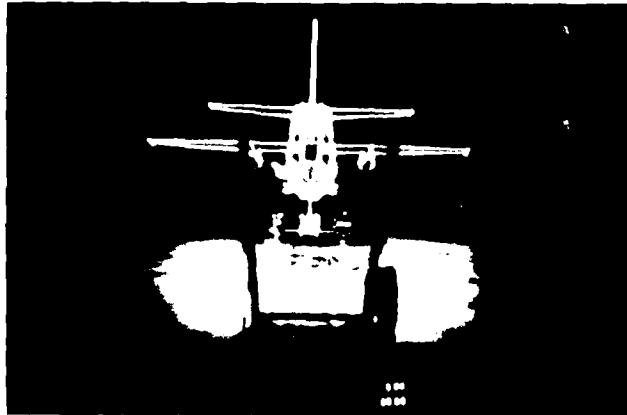

- Fig. 17 -

-) Formation Lights Positioning

The rectangular shaped, electroluminescent, type 1, style B formation lights have never been installed on other previous Italian aircraft.

They present the characteristics of being practically invisible from the ground, and, if carefully positioned on the aircraft and with shape and position optimally determined, they give the wingman a good indication of the leader aircraft attitude, also without any external light source.

The simulation activity is performed using an AM-X leader aircraft image, on which the formation lights can be arranged in different patterns.

As soon as the test pilot familiarizes with the formation flight, the leader AM-X outlines are removed, and the flight continues using the formation lights as the only reference.

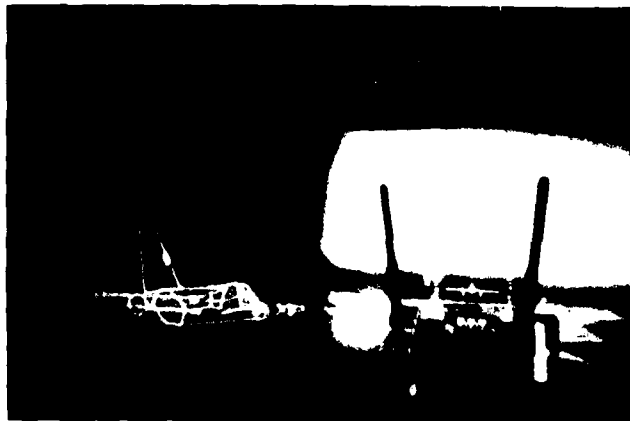

- Fig. 18 -

In this way it has been possible to determine the fuselage and wingtip lights optimum position and dimension, whereas it has not been completely proved if an additional light on the vertical fin is really useful. This activity is still in progress.

Future Aeritalia Flight Simulation Center Development

The most important development of Aeritalia Flight Simulation Center will be the availability by the end of 1980 of a new, advanced generation visual system, consisting of a General Electric Compuscene IV CGI system. This system will enable a decisive leap in visual realism and effectiveness.

The CGI system will be able to generate landscapes, ground targets, aircraft etc. with "photographic" quality, thanks to the texture capability of the Compuscene IV. Three projectors will be used to project the CGI image in the dome, with a FOV of about 130 degrees in azimuth.

Also some other improvements are on the way, to face the ever increasing need of simulation for aircraft development.

Conclusions

Aeritalia AM-X Flight Simulator resulted in a flexible, reliable and powerful means to fulfill its design requirements. The chosen configuration proved to be satisfying, and the pilots and the engineers agree on its effectiveness. However, the degree of realism achievable with a fixed base simulator is lower than that possible on a multi-DOF training simulator, but the visual system developed in Aeritalia performed reasonably well, at the point that future already planned developments in Aeritalia Flight Simulators will retain this basic philosophy.

As previously noted, AM-X Flight Simulator will proceed in carrying on its planned activities during prototype flight testing, giving the pilots the opportunity of practicing before real flight. In addition, any modification both in hardware and software that could arise from the flight test programme could be easily tested in this facility.

Moreover, any future evolution like new aircraft versions, new weapon, updated avionics equipment etc. will be studied on this simulator.

RADAR SIMULATORS

by

J.C. Pietrement
 Development Engineer
 Thomson-CSF
 3 Ave Albert Einstein
 B.P. 116
 78192 Trappes Cedex
 France

ABSTRACT

The diversity of on-board radars, the required training in their use and the need for preliminary testing prior to their definition led THOMSON-CSF SIMULATEURS to develop a multifunction radar simulator architecture offering maximum flexibility. This modular architecture makes possible a wide variety of products from simple training equipment to the most sophisticated research simulators. In addition, it can be adapted as radar techniques develop.

Introduction

The first radar simulators were used only for training pilots. The number of simulated modes was limited and the modeling was simplified. However, today's radar simulators are designed to allow them to be used as:

- radar design aid: these are radar research simulators used to evaluate the influence of radar parameters on the image and to test certain algorithms. The large number of adjustable parameters, the simplicity of use, the accuracy make it an efficient equipment design aid tool
- pilot training facility to familiarize the pilots with the images, the modes and the navigation and slewing procedures.

By the use of data processing, radar functions, formerly limited to passive image display, have become more active: the radar is now capable of flight control.

The radar simulator has been similarly enhanced. Its functions are no longer limited to computation of the image and it participates more actively in flight simulation.

The radar simulator provides images of a real or simulated terrain under a variety of meteorological conditions. The image resolution is adapted to the modes of the simulated radar:

- air-ground modes: ground mapping, contour mapping, blind letdown, terrain avoidance, terrain following
- air-air modes (search, lock-on, tracking, etc.)
- meteorological modes
- air-ground ranging mode
- beacon mode
- interlaced or alternating modes combining several of the above modes.

In these modes, the parameters, equations or algorithms can be confidential. In order to preserve confidentiality, these elements can be remoted to a processor which the user can program in a high level language. The results can be evaluated in real time. This capability can be used in particular in terrain-following mode.

The user, with a contour of the terrain seen by the radar and the aircraft characteristics, position and attitude in space, can thus optimize the mission profiles according to the terrain contour. In this mode, the image generator returns the elevation-range profile to the processor several tens of times a second.

The simulator architecture includes (see figure):

- a data base (DB)
 This data base contains the information relative to each mode: all the regions which can be flown over by the aircraft for the air-ground modes, the meteorological conditions and cloud descriptions for all modes, the beacon positions, etc.
- a management processor
 This processor manages the data base. It has the characteristics of a general purpose computer. It can therefore share the facilities of the flight simulator.
- a local data base (LDB)
 This data base contains the data from the DB required for computing the image.
- a radar image computer (RIC)
 This computer generates the image from the data from the processor and the LDB

- a display unit
The display unit can be the real equipment or substitution equipment adapted to image display.
- an instructor's station
The instructor's station is generally integrated with that of the flight simulator.

RADAR SIMULATOR ARCHITECTURE

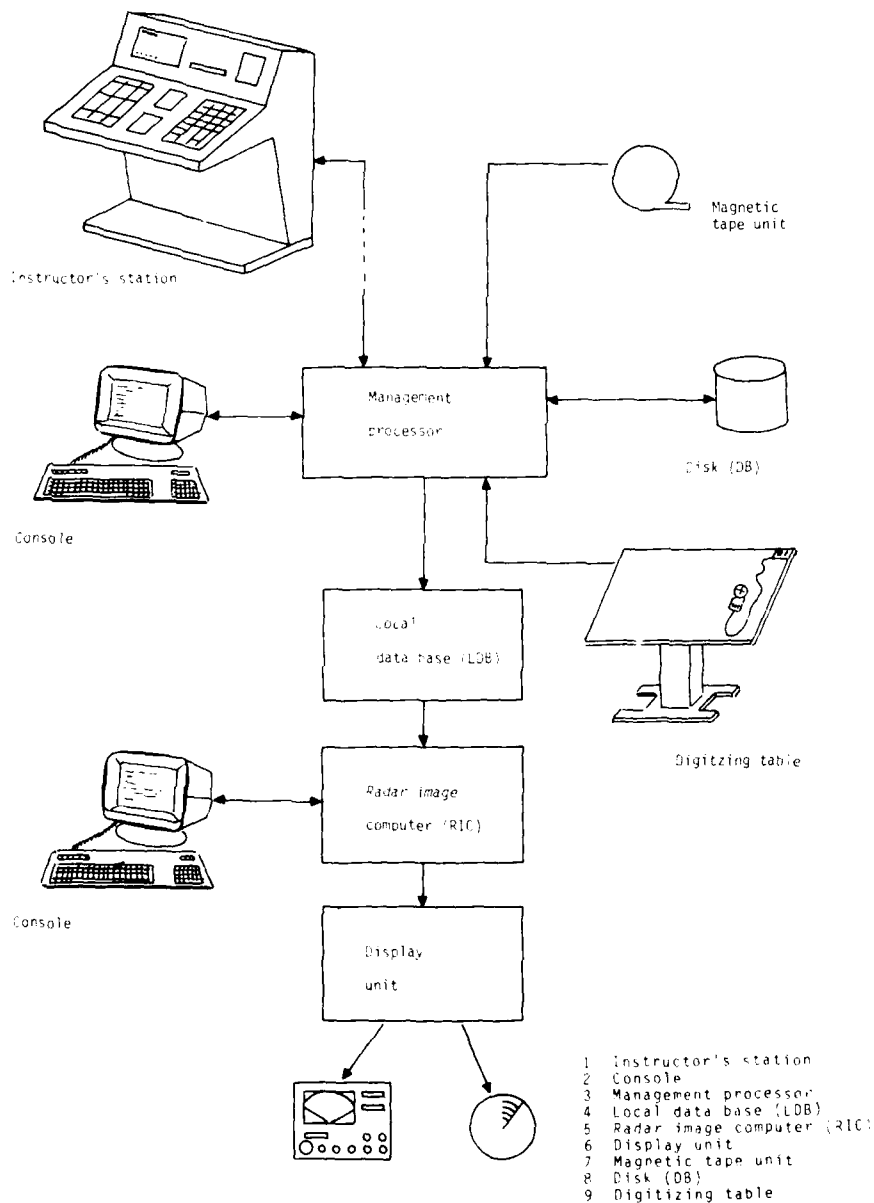

Data Base (DB)

Management of a large data base is required to obtain a radar image. The problems are similar to those of data bases which generate visible images of the outside world:

- creation
- management
- fast access.

The data base is obtained in two ways:

- analysis of DMA (Defense Mapping Agency) magnetic tapes or similar. They describe zones finely digitized in planimetry and altimetry
- manual digitizing.

For use of DMA tapes, a compiler automating all the following processes is necessary:

- creation of meshed files with different resolutions organized by latitude-longitude
- computation of the elements of information and creation of the contents of each element of the data base
- insertion of very detailed zones for a particular application.

Manual digitizing is rarely used. It serves to clarify and add planimetry details when they do not exist, create fictive zones for a special mission or an operational evaluation of the algorithms in a specific mode. Digitizing always requires the use of a compiler.

The precision of the data base obtained with DMA tapes is presently around 75 m. From these files are created several other files with resolutions adapted to the radar or to the various scales of the radar.

Very detailed areas can be stored. They make it possible to provide accurate images for ground target recognition, for instance, or to evaluate the image on a given terrain. The resolution of such areas can be better than 10 m. The image realism depends on the quality of the data base. Therefore, all the information characterizing the terrain is stored:

- terrain altitude
- orientation of the terrain mesh normal
- reflectivity of the terrain or radar cross section
- radiation pattern of the mesh in space
- type of mesh * terrain
* particular feature.

The richness of the data contained in the data base allows accurate reproduction of the effect of the terrain characteristics on the image.

The data base is stored on disks which combine a high storage capacity with a fast access time.

Two types of disks can be used:

- magnetic disks, with a smaller capacity but allowing both read and write. Memory space can also be reserved for special files which vary with time or mission type
- digital optical disks which offer a larger capacity at a lower cost. Their use is simplified and the environmental conditions are standard. In addition, they are smaller in size but, unfortunately, can only be written on once.

Two 500 Mbyte disks can store an area of 10^6 km² for an average latitude of 45 degrees.

Management Processor (MP)

This processor performs the following functions:

- data base creation/management
- flight parameter acquisition
- read of pilot selections
- user-radar simulator dialog.

It can be located on the flight simulator computer or any other computer.

Local Data Base (LDB)

The access time to the data base stored on disk is long as regards the time required to compute a point of the image. Therefore, a local data base (LDB), smaller in size but with a much faster access time, is updated as the aircraft advances. It contains the area flown over by the aircraft required for generation of the image. Its resolution depends on the scale selected.

The capacity of the LDB can be extended according to the carrier capabilities (linear speed and rate of turn) and the radar (resolution, scale, etc.). The typical average access time is 250 ns for a volume of several 32-bit megawords.

The update is performed by the management processor itself or by a dedicated processor.

Its access is shared by several users:

- the management processor or dedicated processor
- the analysis processors which are part of the radar image computer.

Radar Image Computer (RIC)

The function of this computer is to compute the image points and send them to the display unit.

The computation power required can vary widely according to the radar simulated. The architecture selected for the RIC is of the multiprocessor type.

The factors taken into account for generation of the image and which influence the characteristics of the RIC are:

- the physical characteristics of the radar (transmit power, pulse width, PRF, noise factor, amplifier type, FTC, gain, beamwidth, rotation speed, Doppler, etc.)
- the aircraft performance capabilities: linear speed and rate of turn, type of mission, etc.
- internal radar processing (fining process, angle error tracking, echo cancellation, etc.)
- the meteorological conditions (clouds, fog, rain, etc.)
- the selections made by the pilot (scale, mode, gain, sweep, etc.).

The functions are shared by two dedicated computers, each of which includes several independent processors operating in parallel. The first computer performs the following tasks:

- search for the points in the LDB for an analysis line
- computation of the radar equations for each point
 - . attenuation with range
 - . computation of the reflectivity according to the type of echo, its cross section, the radiation pattern, the surface orientation
 - . computation of the masking
 - . the various gains and fining processes
 - . refraction of the wave and meteorological contributions
- corrective processing (earth's curvature, rhumb line error/meridian convergence effect correction)
- mode management
antenna scan laws, computation of parameters.

All the computations are floating point with a dynamic range of nearly 200 dB.

The second computer performs the following functions:

- computation of the effects due to the reception system: antenna beamwidth, range resolution, noise factor, PRF, type of amplifier, raw or synthetic video
- conditioning of the output data for the display unit
- generation of ancillary functions (test images, clocks, etc.).

The computations are made with a dynamic range of nearly 100 dB.

To have a low false alarm rate, a radar must confirm the presence of an echo over several sweeps, whereas the simulator accurately knows the position of all the elements. The computation is therefore performed only once and a detection probability identical to that which would be given by the radar is associated with it.

In addition, bottlenecking of the data occurs at the display unit. Its size, its resolution and the possible associated memory limit the amount of data which can be displayed. It is therefore often the display unit which determines the quantity of data to be computed.

The computation power of the RIC allows generation of 500 000 to 1 million points per second according to the complexity of the processing in the mode selected. However, many more points must be sent to the screen (multiplied by a factor of 2 or 3) to preserve the realism of the image displayed.

The multiprocessor architecture allows meteorological conditions to be included in the computations. One of the processors analyzes the meteorological situation in the area flown over by means of the same LDB containing meteorological and air-ground data for instance. The other processors analyze the terrain. The mapping and meteorological data are thus computed simultaneously.

The RIC is implemented with bipolar bit-slice computers. Their use associated with VLSI components allows an increase in speed while minimizing the size of the functional modules.

Distributed processing of the computation allows a large amount of reserve computation power to be preserved in the "executive" computer for future addition of new functions.

In addition, the modular design of the cards allows the required computation power to be obtained simply by adding cards. The simulator can thus easily follow developments in the radar.

Display Units

The display units are the real equipment or simulated units. In the second case, the important criterion is equivalence from the standpoint of the user. This equipment can be replaced by more flexible image display systems for research radars.

Instructor's Station

The instructor's station provides the following functions:

- radar type selection if several radars are simulated
- selection of the radar failures requested by the instructor
- monitoring of the images seen by the trainee
- target control (joystick).

In addition, the radar simulator can carry out the following functions during the time not occupied by computation:

- simulation of a tactical environment
The RIC computes detection of the aircraft by external threats taking into account masking by the terrain. This allows activation of countermeasures
- computation of the radio beacon height
The LDB allows computation of the radio beacon height taking into account the transmission lobe of the beacon
- aid for the instructor
The RIC can control several targets in terrain-following mode for instance. For target tracking, the target paths above the terrain are very realistic. They are monitored by the instructor.

Conclusions

The more sophisticated radars become, the more accurately the three target coordinates: elevation, azimuth, range are known. The simulator already knows how to accurately compute these coordinates and will therefore have no trouble in generating the future radar images, in particular 3D images.

The Development of the T-46 Next Generation Trainer Manned Engineering Simulator
at the U.S. Air Force Flight Test Center

by
Jonathan C. Pick
Simulation Engineer
6520 Test Group
ENFS/Mail Stop 239
Edwards Air Force Base, CA
93523 U.S.A.

SUMMARY

This paper describes the development and structure of the T-46A flight test simulation at the U.S. Air Force Flight Test Center, and emphasizes two interesting aspects of the simulation:

1. An electrohydraulic force-feel system is driven by a digital computer to model a reversible flight control system. This led to some force-feel system instabilities that had to be eliminated.

2. Data for extremely high angles-of-attack are incorporated into the simulation in order to simulate aircraft stall, departure, spin, and recovery.

As a tool for supporting flight test operations, the T-46 simulation will be used for planning, practice flying of flight tests, and to facilitate the development and evaluation of aircraft modifications (especially those involving the flight control system). This necessitates the use of very versatile software which can be changed daily to support daily flight operations. In addition, a simulation that can accurately model flight conditions on the edges of the flight envelope greatly enhances the safety and efficiency of flight tests.

Since handling qualities is the primary area of interest in this simulation, certain elements of the simulation are of key importance. One of these is control stick "feel". Modelling stick "feel" was not straight-forward on the T-46A simulation. The aircraft has a reversible flight control system, which means that stick force is a function of a number of flight condition parameters as well as stick position. This mandates the use of a computer for controlling the force-feel system. The use of an electrohydraulic force-feel system with this kind of digital control caused a number of challenges related to force-feel system stability, which this paper will describe along with the solutions implemented.

Another unique feature of the Air Force Flight Test Center's T-46A simulation is the incorporation of rotary balance aerodynamic data (angles-of-attack to $\pm 90^\circ$ and non-zero spin rates) to simulate departure and spin characteristics. This T-46A simulation is the first U.S. Air Force simulation to use such data. This capability allows the flight test team to safely determine the limits of controllability, while at the same time reducing the number of actual aircraft flights required for departure susceptibility and spin recovery testing.

SYMBOLS

C_C	Chord Force Coefficient
C_M	Pitching Moment Coefficient
C_N	Normal Force Coefficient
C_Y	Side Force Coefficient
C_l	Rolling Moment Coefficient
C_n	Yawing Moment Coefficient
Sgn	Algebraic Sign of a number (+1 or -1)
P	Body Axis Roll Rate
Q	Body Axis Pitch Rate
R	Body Axis Yaw Rate
Ω	Rotation Rate About Free Stream Velocity Vector
τ	Empirical Time Constant
*	Generic Force or Moment Coefficient

SUBSCRIPTS

CONFIG	Coefficient Due to Configuration (Flaps, Landing Gear, Speedbrakes)
DAMP	Coefficient Due to Body-Axis Rate Damping
STAB	Stability Coefficient (e.g., C_{Ma} , C_{NB})
δCNTRLS	Coefficient Due to Control Surface Deflection
HIGH α	Extended Angle-Of-Attack Coefficient
ROT	Rotational Increment
o	Basic
PXT	Aileron Fixed Position Tab
LG	Landing Gear
OSC	Oscillatory Component
TAB	Roll Trim Tab
α	Angle-of-Attack
$\dot{\alpha}$	Time Rate Of change Of Angle-of Attack
β	Sideslip Angle
δA	Aileron Deflection
δE	Elevator Deflection
δF	Flap Deflection
δSB	Speedbrake Deflection

BACKGROUND

FLIGHT TEST SIMULATION

There are several very important jobs that performance and flying qualities flight test simulations frequently perform. They are often used for the study of aircraft modifications. Changes proposed for an aircraft are modeled in simulation software, and evaluated relatively inexpensively and easily in simulated flight. By examining possible modifications in this way, the changes made to the actual aircraft can be better optimized. Parametric studies in the simulator can also determine how sensitive aircraft behavior is to variations in aerodynamic derivatives and coefficients. This is a good way to gain insight into aircraft characteristics and to determine how sensitive flying qualities predictions are to uncertainties in aerodynamic data.

Flight test simulations also can be used to reduce flight test costs by helping to plan an efficient and economical flight test program. Risks for hazardous conditions and maneuvers can be greatly reduced if the hazards are first found and explored in a simulator. The rehearsal of test missions in a simulator aids immensely to pilot and engineer mission familiarity, and improves coordination between them during flight.

Because performance and flying qualities flight test simulations are used for particular tasks, certain aspects are of special concern, and are emphasized while other aspects are deemphasized. It is essential that the aircraft flight control systems be accurately modeled if the simulator's handling qualities are to resemble those of the aircraft. It is also necessary that the primary controllers feel like those in the aircraft. This means that stick and rudder placements, travels and, especially, forces must be very carefully calculated and output to the simulator cockpit. Key to both flying qualities and performance is high fidelity in modelling the aircraft aerodynamics.

However, most important of all is versatility. If the simulation is to be a convenient tool, the software must be structured with a great deal of flexibility built in. Changes and additions to data must be easily accommodated. Individual coefficients and derivatives must be readily accessible and should retain their identities throughout the simulation. Computer code should be easily understandable and must be quickly and conveniently altered.

DESCRIPTION OF THE U.S. AIR FORCE FLIGHT TEST CENTER FLIGHT TEST SIMULATION FACILITY

The flight test simulation facility is equipped with the following:

1. 4 cockpits, all with single-CRT visual systems, one with a motion base.
2. 6 Perkin-Elmer 8/32 minicomputers.
3. 2 Gould Systems-Engineering-Laboratories (SEL 32/55) minicomputers.
4. An Applied Dynamics AD-10/Digital Equipment PDP-11 array processor complex.
5. A variety of digitizers, plotters, and stripchart recorders.

The T-46 Flight Test Simulation uses the Equipment listed below (figure 1):

1. Two Perkin-Elmer 8/32 minicomputers. These handle all of the realtime processing except for generation of visual displays.
2. One Gould SEL 32/55 minicomputer. This computer takes position and attitude information from the Perkin-Elmer computers and drives the display generator.
3. One Aydin display generator. This drives the CRT visual system in the cockpit.
4. One cockpit. Fabricated in-house, the cockpit includes reproductions of all relevant controls, displays and instruments. Special attention was paid to the stick, pedal, seat, and instrument panel geometries.
5. One McFadden Model 392A control loader. Force-Feel for the stick and pedals is provided by this electrohydraulic servo system.
6. One Singer-Link motion platform. The motion platform is controlled by the Perkin-Elmer computers to provide motion cues to the pilot.
7. One Denelcor analog-to-digital converter. This is the interface between the computers and the cockpit.

SYSTEM AND T-46 SIMULATION SOFTWARE PHILOSOPHY

The system software and simulator-specific software have a number of special features in order to be as versatile as possible, and to facilitate quick response to changes in aircraft data and in simulator-user requirements. Code is modularized, with the modules differentiated according to function. To make it easier to understand what is happening physically, almost all code is written in FORTRAN, and many variable names are standard between different simulations. Some code modules are also standard between simulations. These include atmosphere, equations of motion, and test input modules. The module which calculates atmosphere parameters, for example, is common since all aircraft fly in the same atmosphere. The use of standard modules shortens initial coding time because less code needs to be written. It also gives all engineers in the facility a basic familiarity with each project in the laboratory, meaning that any engineer in the facility can work on any project if necessary.

Aerodynamic data in the simulation is set-up as an entity completely separate from the code modules. Because of this, it is easy to swap entire sets of data, or to try different code with data unchanged.

The software features described above help greatly in using the simulator as a flight test tool. For example, suppose that a spring is to be added to one of the flight control system components. A new code module containing the spring can be created. By switching back and forth between the prototype and original modules, a direct comparison of flying qualities between spring and no spring cases can be made. As another example, a particular coefficient based on wind tunnel predictions can be updated with flight test data. Again, direct comparisons can be made in a single session to determine how the data change may affect the flying qualities of the aircraft.

DESCRIPTION OF THE T-46 AIRPLANE

The mission of the T-46A Next Generation Trainer is to replace the U.S. Air Force's T-37 basic trainer fleet. The T-46A is designed to be more economical than the T-37, and to have increased performance and capabilities.

The T-46A is a twin-engined aircraft, using the relatively high bypass ratio Garrett F-109 Turbofan engine. The airplane has a shoulder mounted wing with slight anhedral, and twin vertical stabilizers and rudders. The cockpit is pressurized and offers side-by-side seating for instructor and student (Figure 2).

The aircraft has a conventional center stick and pedals. The longitudinal flight control system is completely reversible, that is, the stick has a direct mechanical connection to the elevator. Roll control is also reversible, but the ailerons incorporate spring tabs to reduce lateral stick forces. Roll trim is through a trim tab which is separate from the aileron system. The directional flight control system is not reversible, as the rudder is actuated through hydraulics, and is equipped with a yaw damper.

FLIGHT CONTROL SYSTEM MODELING

CONTROL LOADER

Stick and rudder pedal feel is, of course, very crucial to a good handling qualities simulation. A great deal of the development effort on this simulation went toward doing a good job of simulating control feel. The laboratory's existing control loader was used.

Essentially, the unit is an analog force servo, converting voltage inputs to force outputs. The following force-feel characteristics can be simulated and adjusted through a wide range of values:

- Breakout Force
- Coulomb Friction
- Damping
- Deadband (slop)
- Force Gradient Schedule
(piece-wise linear)
- Travel Limits

The control loader was designed to operate as a self contained system with no input commands from external sources. The control loader normally outputs voltages corresponding to controller forces, positions, and velocities for use in the computer computation of control surface positions. However, the control loader can accept commands from a computer to drive controller position and/or force. The T-46 simulation made use of the latter capability and several challenges had to be overcome to obtain satisfactory fidelity.

IMPLICATIONS OF REVERSIBLE FLIGHT CONTROL SYSTEMS

Both the lateral and longitudinal flight control systems on the T-46 aircraft are reversible, meaning that the stick is mechanically connected to both the elevator and ailerons with no hydraulic or electrical actuators. Because of this direct mechanical connection, stick force is primarily a function of the aerodynamic hinge moments on the control surfaces. In addition, components such as bobweights, springs and linkages also come into play if they are present. All of this means that stick force in what is seemingly a simple flight control system is a function of stick position, tab position, angle-of-attack, pitch rate, Mach number, dynamic pressure and load factor. It is apparent that simulating (with high fidelity) stick feel for an airplane with reversible flight controls requires a sophisticated model using numerous table lookups and calculations. The required complexity and the necessity for easy changeability in the T-46 flight test simulation far exceeded the pre-programmed capabilities of the control loader, and mandated that force feel be controlled by the digital computers.

LONGITUDINAL FLIGHT CONTROL SYSTEM

The elevator system on the T-46A airplane is rigid if cable stretch and linkage deformation are neglected. This means that each stick position will correspond to a unique elevator deflection. The simulation software takes pitch stick position, measured by the control loader, and calculates the corresponding elevator deflection. This is used along with the measured time rate of change of stick position and calculated flight condition information to compute a stick force command. The commanded stick force is output to the control loader. In the approach taken, simulation software accounts for many effects:

1. Basic aerodynamic hinge moment due to elevator deflection
2. Hinge moments due to elevator trim tab deflection
3. Bobweight and elevator mass imbalance effects with load factor
4. Effects of linkages and springs

In addition, the control loader hardware is used to model friction and damping of the airplane elevator system.

ROLL FLIGHT CONTROL SYSTEM

The aileron system is, like the elevator system, mechanical. The simulation software takes measured stick position and flight condition information, and calculates the deflection of each aileron and each spring tab. Lateral stick force is then calculated and sent as a command to the control loader. Roll flight control system software models:

1. Hinge moment due to each aileron
2. Hinge moment due to each spring tab
3. Mechanical linkages and springs
4. Roll trim tab operation

Friction and damping are simulated by the control loader hardware in the same manner as for the longitudinal flight control system.

DIRECTIONAL FLIGHT CONTROL SYSTEM

The T-46A directional flight control system is hydraulic and is not reversible. Rudder pedal forces are determined solely by pedal position. In the simulation, the rudder pedal force gradient schedule, breakout forces, friction and damping are all pre-set in the control loader, while rudder deflection is computed in the software.

FORCE-FEEL SYSTEM FIDELITY (ROLL AND PITCH)

Significant challenges had to be overcome in order to provide satisfactory fidelity in force-feel characteristics with the use of the digital computers to drive the analog circuitry of the control loader. This situation arose because of the characteristics of this particular implementation. The digital computers operated in discrete 20 millisecond frames during which calculations, inputs, and outputs took place. However, the analog control loader operated continuously with no discrete frames, and usually with relatively small lags. The 20 millisecond frame time led to "stick ratcheting". Also, in this particular implementation, the frequency response characteristics of the control loader were marginal.

Since the computers operated in discrete cycles, the commanded stick force was updated discontinuously. The stick force felt by the pilot was "bumpy". This can be distracting to pilots, especially in flight regimes with high stick forces, and can undermine pilot confidence in the simulation. Efforts to find methods that would minimize the ratcheting (such as faders and filters) were largely ineffective. The approach taken was to minimize time between updates of stick force, keeping the "bumps" as close together as possible. This was accomplished by minimizing the frame time.

Another major factor was that the stick could be unstable. At high stick forces the phase lag of this control loader arrangement reached 180° (Figure 3). In the initial set-up, the stick frequently had an oscillating, divergent motion which was on occasion violent enough to damage cockpit hardware. Although the phase lag could not be totally eliminated, its effect was reduced substantially. Originally, the stick was divergent for nearly all flight conditions. With work-arounds the stick was stable over virtually the entire flight envelope. The solution was through a mixture of software and hardware measures.

The primary software fix was the addition of terms for control aerodynamic hinge moments due to control surface deflection rates. Hardware measures taken included the use of the analog control loader electronics to simulate flight control system friction and pre-programming additional first-order damping into the control loader. All of these hardware and software measures together effectively managed the instability problem (Figure 4). Instability occurred only with high stick force gradients (i.e. high equivalent airspeeds), which were generally beyond the aircraft's flight envelope. Even so, damping could be further increased if very high speed work was to be done, and reduced for all other work. Although this provided correct static stick forces, the fidelity of the force-feel characteristics in dynamic situations was lowered.

HIGH ANGLE-OF-ATTACK DATA

GENERAL INFORMATION

The United States Air Force T-46 Flight Test Simulation used a data set which made the simulation capable of accurately modelling the flight of the T-46A Aircraft from level 1'g' flight through stall, departure, spin and spin recovery, both upright and inverted.

The data which make possible such a wide range of flight conditions were generated by the Bihrie Applied Research Company for the Air Force using the National Aeronautics and Space Administration-Langley Research Center's twenty-foot spin tunnel. The vertically-oriented tunnel has a rotary balance, which allowed a model to be steadily rotated in the wind stream. This enabled the aerodynamic effects of steady-state rotation to be quantified. The balance also permitted data to be obtained over a complete range of angle-of-attack and sideslip angle. Until recently, aerodynamic data of this scope had not been available, and the T-46 flight test simulation represented the first use of rotary balance data by the United States Air Force. The United States Navy had been actively interested in rotary balance high angle-of-attack/spin data, and preceded the Air Force by obtaining models for the F-14 and EA-6B aircraft.

The availability of a good high angle-of-attack simulation greatly enhances the flight test program. The simulation can be used as a tool to predict, before flight test, conditions which will result in a spin. Spin modes and, especially important, recovery techniques can be examined before flight. Pilots can practice spin entries and recoveries before they fly. This all means that the flight test program will be safer, and shorter than it would be without the high angle-of-attack simulation.

The airplane stall and spin characteristics can also be explored more fully in the simulator than can be practically done in the airplane. The simulator's safety permits dangerous or extremely uncomfortable maneuvers to be easily investigated. The versatility of the simulation makes it very easy and economical to study in detail the effects of airplane mass properties, pilot technique, and flight condition on stall and spin behavior.

IMPLEMENTATION

The T-46 flight test simulation was valid over the entire range of:

1. $-90^\circ \leq \text{angle-of-attack} \leq +90^\circ$
2. $-30^\circ \leq \text{sideslip} \leq +30^\circ$
3. Zero to high rates of rotation about the free stream velocity vector.

This was accomplished by combining rotary balance and static high angle-of-attack results with conventional non-rotational, low to moderate angle-of-attack data. In operation, the conventional aerodynamic data were used during flight at low to moderate angles-of-attack. When the angle-of-attack was greater than twenty degrees or less than minus eight degrees, the extended angle-of-attack data were used. Irrespective of angle-of-attack, increments for the effects of rotation were added to each major static coefficient or derivative if there was any steady rotation. The equations used to calculate the total force and moment coefficients had the following form:

$$C_H = \underbrace{C_{H_{STAB}} + C_{H_{CENTRLS}} + C_{H_{CONFIG}} + C_{H_{DAMP}}}_{\text{Conventional Aerodynamics}} + \underbrace{C_{H_{D}} + C_{H_{STAB}} + C_{H_{CENTRLS}} + C_{H_{CENTRLS}} + C_{H_{DAMP}} + C_{H_{DAMP}}}_{\text{High Angle-of-Attack/Spin Aerodynamics}}$$

$C_{H_{D}}$ HIGH α
 $C_{H_{STAB}}$ ROT
 $C_{H_{CENTRLS}}$ HIGH α
 $C_{H_{CENTRLS}}$ ROT
 $C_{H_{DAMP}}$ HIGH α
 $C_{H_{DAMP}}$ ROT

A complete set of the equations is listed in the Appendix.

All of the rotational increments are functions of Ω , the steady rotation rate about the free stream velocity vector. The damping derivatives are multiplied by the steady, oscillatory components of the rates (POSC, QOSC, ROOSC). The definitions for Ω and the oscillatory rate components are given below

$$\Omega = \frac{1}{\sqrt{P^2 + Q^2 + R^2}} (P \cos \beta + Q \sin \beta + R \sin \alpha \cos \beta) \text{Sgn } \alpha$$

$$\text{POSC} = P - \Omega \cos \beta \cos \alpha \text{Sgn } \alpha$$

$$\text{QOSC} = Q - \Omega \sin \beta \text{Sgn } \alpha$$

$$\text{ROOSC} = R - \Omega \cos \beta \sin \alpha \text{Sgn } \alpha$$

The term $\frac{1}{\tau S+1}$ is a filter determined empirically by Bihle Applied Research Co. to remove oscillatory components from the rotation rate about the freestream velocity vector. Only the steady rotation components are used with the rotational increments because the rotary rig produces only steady rotation rates. The effects of the filter on $\dot{\alpha}$ in a typical spin are illustrated in Figure 5. As can be seen, the filter smoothes the magnitudes of the oscillations. Also, more time is required for $\dot{\alpha}$ to reach its final value. It should be noted that the frequencies of the oscillations are the same in either case.

CORRELATION WITH OTHER RESULTS

As of the writing of this paper, the T-46 aircraft has not flown. However, the U.S. Navy had good comparisons with actual flight test data. The only comparison available for the T-46 simulation was with preliminary results from a hand-launched free-flight spin tunnel model, and with results from a batch digital computer simulation by Bihle Applied Research. A comparison of results for spin parameters at identical flight conditions and mass properties from the two simulations and the free-flight model are given in Table I. The results agree reasonable well and show essentially the same characteristic motions.

SUMMARY

The T-46 simulation at the Air Force Flight Test Center came about as a tool for the aircraft handling qualities and performance flight test effort. As such, the simulation was flexible and easily understood by engineers. Modelling of the aerodynamics and of the flight controls was of high fidelity. The direct, reversible mechanical nature of the T-46A flight controls made simulating stick feel troublesome, but not impossible. This simulation introduced to the U.S. Air Force the capability to accurately simulate flight from high speed cruise through spin and spin recovery, using rotary balance aerodynamic data. The net result was that the airplane flight test program had a tool for safer and more efficient flight test.

REFERENCES

1. McFadden Electronics Company, South Gate, CA USA, Instruction Manual For Model 392A Control Loader,
2. Bihle, W. Jr. and Barnhart, B., Spin Prediction Techniques, Journal of Aircraft, Vol 20, No. 2, Feb 1983.
3. Bihle, W. Jr., Prediction of High Alpha Flight Characteristics Utilizing Rotary Balance Data, 13th ICAS Congress AIAA Aircraft Systems Technology Conference Proceedings, Aug. 1981.
4. Ralston, John, Low Speed Aerodynamic Model of the T-46A for an Angle-of-Attack Range of -90° to $+90^\circ$, Bihle Applied Research 85-9, Aug. 1985.

TABLE I
SPIN PARAMETER COMPARISON

	Condition	Spin Rate (Sec/Turn)	Angle-of-Attack (Deg)	Rate of Descent (Ft/Sec)	Turns to Recover
USAF Flight Test Center	1	2.2	43	198	2.0
Bihle Applied Research	1	2.3	42	243	1.3
Free-Flight Model (preliminary)	1	2.4	40	239	1.5
USAF Flight Test Center	2	2.2	56	177	2.0
Bihle Applied Research	2	2.4	59	187	2.3
Free-Flight Model (preliminary)	2	2.2	61	187	2.5
USAF Flight Test Center	3	2.8	57	197	1.0
Bihle Applied Research	3	2.8	59	198	1.0
Free-Flight Model (preliminary)	3	3.3	60	190	1.0

APPENDIX
T-46 SIMULATION AERODYNAMICS

If $-8^\circ < \alpha < 20^\circ$,

$$C_N = C_{N_0} + C_{N(\delta E)} + C_{N(\delta F)} + C_{N(LG)} + C_{N(\delta SB)} + C_{N(FXT)} + C_{N_0(ROT)}$$

$$C_C = C_{C_0} + C_{C(\delta E)} + C_{C(\delta F)} + C_{C(LG)} + C_{C(\delta SB)} + C_{C(FXT)}$$

$$C_Y = C_{Y(\beta)} + C_{Y(\delta A)} + C_{Y(\delta R)} + C_{Y(POSC)} + C_{Y(ROSC)} + C_{Y_0} + C_{Y(POSC)ROT} + C_{Y(ROSC)ROT}$$

$$C_M = C_{M_0} + C_{M(\delta E)} + C_{M(\delta F)} + C_{M(LG)} + C_{M(\delta SB)} + C_{M(FXT)} + C_{M(THRUST)} + C_{M(QOSC)} + C_{M(\dot{\alpha})} + C_{M_0ROT}$$

$$C_L = C_{L(\beta)} + C_{L(\delta A)} + C_{L(\delta R)} + C_{L(TAB)} + C_{L(POSC)} + C_{L(ROSC)ROT} + C_{L(\beta)ROT} + C_{L(\delta A)ROT} + C_{L(POSC)ROT} + C_{L(ROSC)ROT}$$

$$C_n = C_{n(\beta)} + C_{n(\delta A)} + C_{n(\delta R)} + C_{n(TAB)} + C_{n(POSC)} + C_{n(ROSC)ROT} + C_{n(\beta)ROT} + C_{n(\delta R)ROT} + C_{n(POSC)ROT} + C_{n(ROSC)ROT} + C_{n(ROSC)ROT}$$

If $\alpha \leq -8^\circ$ Or If $\alpha \geq +20^\circ$

$$C_N = C_{N_0(HIGH \alpha)} + C_{N_0(ROT)} + C_{N(\delta E)(HIGH \alpha)}$$

$$C_C = C_{C_0(HIGH \alpha)} + C_{C(\delta E)(HIGH \alpha)}$$

$$C_Y = C_{Y(\beta)(HIGH \alpha)} + C_{Y(\delta A)(HIGH \alpha)} + C_{Y(\delta R)(HIGH \alpha)} + C_{Y(POSC)(HIGH \alpha)} + C_{Y(ROSC)(HIGH \alpha)} + C_{Y_0(ROT)} + C_{Y(POSC)(HIGH \alpha)} + C_{Y(ROSC)(HIGH \alpha)} + C_{Y(ROSC)ROT}$$

$$C_M = C_{M_0(HIGH \alpha)} + C_{M(\delta E)(HIGH \alpha)} + C_{M M(Q)(HIGH \alpha)} + C_{M_0(ROT)} + C_{M(\delta R)ROT}$$

$$C_L = C_{L(\beta)} + C_{L(\delta A)} + C_{L(\delta R)} + C_{L(\text{POSC})} + C_{L(\text{ROSC})} +$$

HIGH α HIGH α HIGH α HIGH α HIGH α HIGH α

$$C_{L(\beta)} + C_{L(\text{POSC})} + C_{L(\text{ROSC})}$$

HIGH α ROT HIGH α ROT HIGH α ROT

$$C_N = C_{N(\beta)} + C_{N(\delta A)} + C_{N(\delta R)} + C_{N(\text{POSC})}$$

HIGH α HIGH α HIGH α HIGH α

$$C_{N(\text{ROSC})} + C_{N(\beta)} + C_{N(\text{POSC})} + C_{N(\text{ROSC})}$$

HIGH α HIGH α ROT HIGH α ROT HIGH α ROT

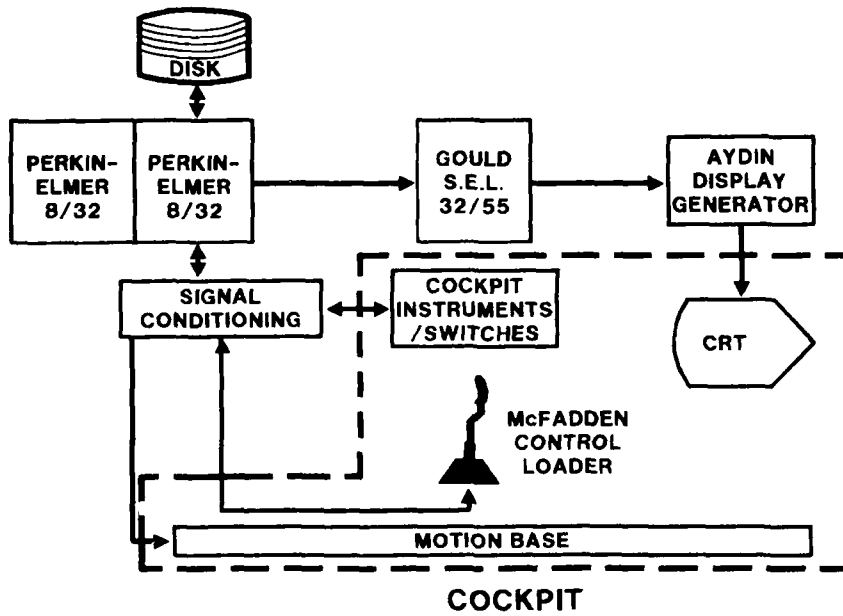

**T-46 SIMULATION HARDWARE ARRANGEMENT
FIG. 1**

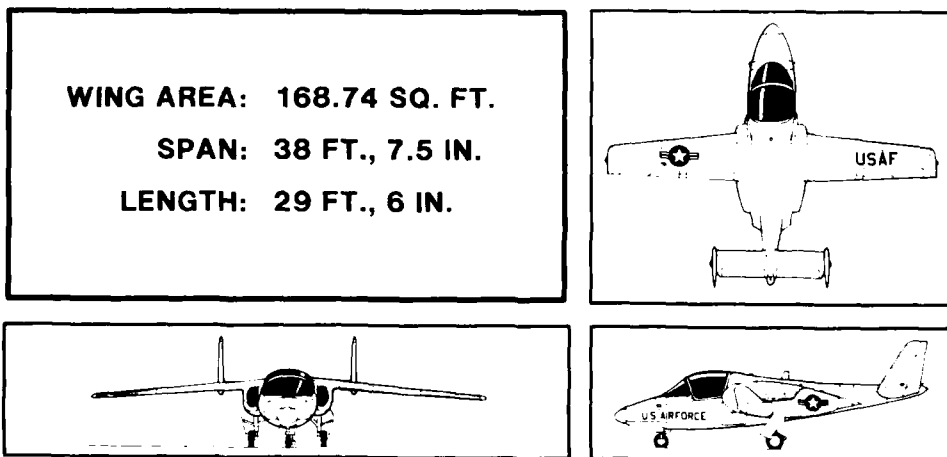

81008.018

**T-46A
FIG. 2**

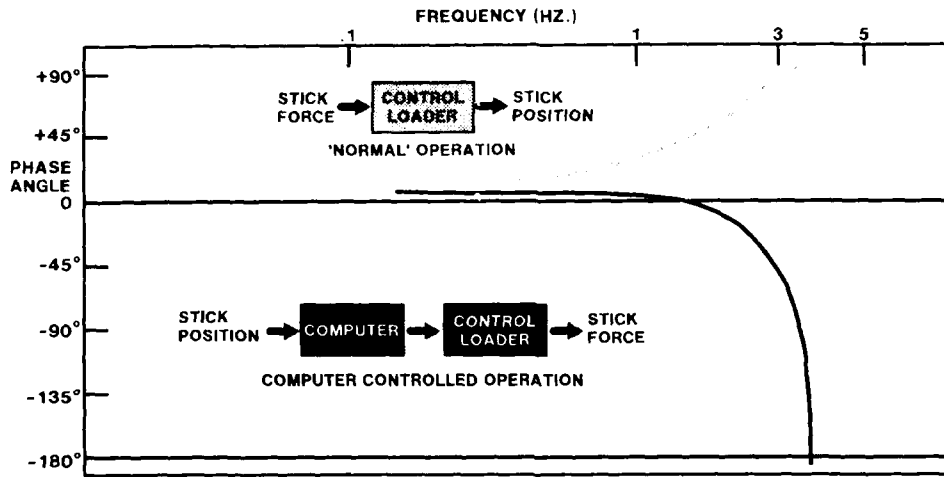

**CONTROL LOADER
PHASE FREQUENCY RESPONSE**

FIG. 3

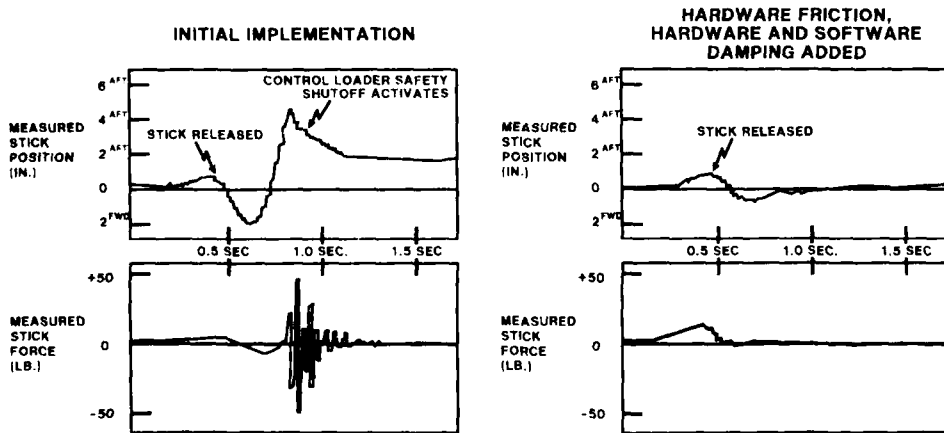

**CONTROL LOADER INSTABILITY
WITH SMALL INPUT**

FIG. 4

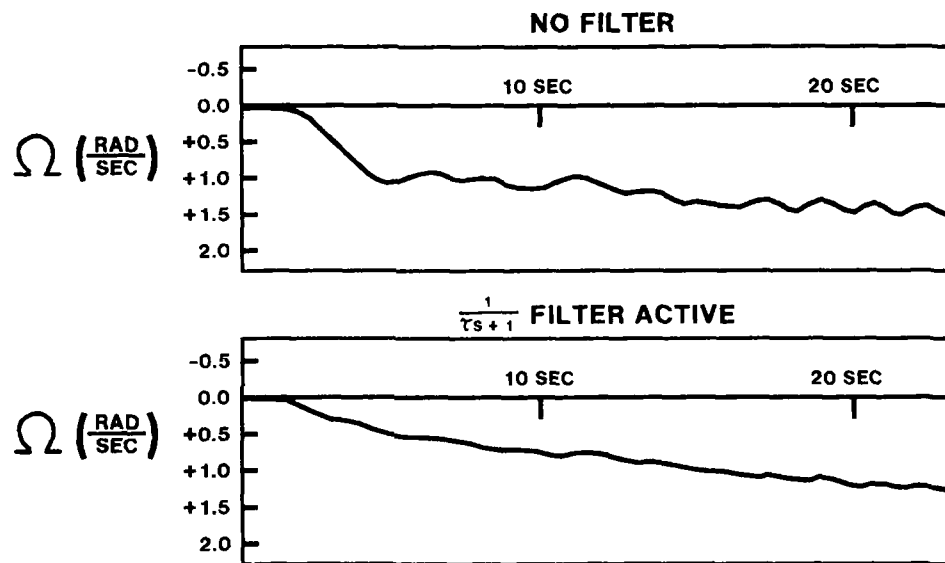

EFFECT OF $1/Ts+1$ FILTER ON Ω DURING A SPIN
FIG. 5

OPERATIONAL TRAINING: APPLICATION AND EXPERIENCE

by

Heinz Friedrich
Dornier GmbH
D-7990 Friedrichshafen 1
Postfach 1420
Federal Republic of Germany

SUMMARY

Possible applications and experience gained in the simulation of missions are described. At first, activities involving operational flight simulation are presented which are performed in the Dornier simulation laboratory and on the Alpha Jet simulator. Following a brief description of the simulator, typical examples will be explained. Then, a specific task on the simulator will be detailed; the development of an air-to-air mode for the HUD (Heads Up Display). In the final section some aspects of operational training on flight simulators in the German air force will be discussed.

1. INTRODUCTION

Activities mission simulation performed in the Dornier simulation laboratory on the Alpha Jet simulator will be described. Also the experience gained in the operational training of the German air force will be discussed.

2. ALPHA JET SIMULATOR IN THE DORNIER SIMULATION LABORATORY

Before considering mission simulation, the simulator itself will be briefly described. Originally, the Alpha Jet simulator in the DORNIER GMBH simulation laboratory was a development simulator that is a type of simulator normally employed to support aircraft design and development. This simulator gradually evolved parallel to the aircraft's development. In the beginning a cockpit mockup provided with control elements and display instruments was hooked to a computer. The expansion gradually led to a fully operational simulator of low cost, but high fidelity - which now is being used for mission simulator in cooperation with the German air force.

Figs. 1-5 give an impression of the Alpha Jet simulator. Fig. 1 provides a general view of the cockpit with the simulator visual system. The block diagram in fig. 2 shows the structure of the simulator and its equipment. In addition to the conventional basic equipment of a development simulator - cockpit, computer interfaces, simulation software - this simulator has a visual system, free programmable display generator with head up display and head down display, stick force simulation, noise simulation, fire control, and the software for threat scenario and mission management.

Fig. 3 provides an impression of the simulator cockpit with visual system while fig. 4 shows the visual system under bad visibility conditions.

Fig. 5 illustrates the instructor and control station which was added in the past years to meet the requirements posed by operational simulation. The figure shows an earlier stage of development. The primary elements are the three monitors with the visual system. In the central monitor, the content of the HUD is also incorporated so that the instructor can see the same information as the pilot in the simulator cockpit. The principal information is provided on the three monitors in the console. The content of the images can be selected at random. The figure shows: on the left-hand side, the cockpit instruments, in the center, data on the simulation software and simulation configuration on the right-hand side, a tactical display.

This is a brief survey of the simulator used. And now we discuss some details on the operational simulations that were performed on this simulator.

3. MISSIONS ON THE ALPHA JET SIMULATOR

The simulation of operational missions started only after the aircraft development had nearly been completed. These activities are performed in close cooperation with the German air force. Figs. 6-11 give an impression of this work.

Since the Alpha Jet has been designed in the first place for air-to-ground missions, mission simulation refers primarily to air-to-ground missions. Fig. 6 provides an impression of a typical air-to-ground mission as it is flown in the simulator. The approach profile is determined with way points (WP) up to the pop up point (PUP), where the target attack (TGT) starts. The individual points - WPs, PUP, TGT - are represented in the simulator visual system.

During operational simulation, all parameters are recorded which are of interest for later flight assessment and further evaluation. Fig. 6 contains the flight path with the left-hand diagram showing the flight path over ground (x, y coordinates) and to the right, the altitude (x, z coordinates). In the computer plot the individual points also have time marks which have been omitted in fig. 6 for reasons of more clarity. In this way, compressed information on flight progress is given.

Naturally, the success of a flown mission is also measured and recorded. Fig. 7 shows the result of an air-to-ground attack as it is printed out on the computer plot. The cross in the centre designates the target position and the points refer to the impact points which are computed from the flight parameters, weapon release moment and ballistic trajectory. This impact protocol also contains all parameters required for documentation or further evaluation. Fig. 7 indicates the flight no., number of rounds, minimum miss distance and CEP-value.

In addition to the above, the activity and effect of ground defence is also shown. Fig. 8 shows such a result. The computer plot shows a two-view drawing of the Alpha Jet with the impact points which would have been scored by the ground defence. Once again, these impact points are calculated from the location of the ground defence, the flight path and the ballistic trajectory. In the scenario illustrated in fig. 8, the ground defence marked by position 3, fired 114 rounds and scored 58 impacts. The figure also shows the location of the impacts. In this case, the ground target was defended by Gepard tanks.

The numerous simulation runs with air-to-ground missions against heavily defended targets have shown approach profiles where the ground defence stands no chance. There are also approach profiles where the aircraft has no chance and all stages in between these two extremes are possible. In this way, new approach profiles were developed for the Alpha Jet with the help of operational simulations with pilots from the tactical wing at Fürstenfeldbruck. It must be noted however the pilot knew ahead of time the type and position of the ground defence. Inaccurate or no knowledge of all of these facts will provide elements of surprise and a new situation - as is the case in a real threat.

Now, 2 pictures are presented to show typical missions performed on the Alpha Jet simulator. Fig. 9 presents an attack profile developed for the simulation on the basis of suggestions by pilots from the tactical wing at Memmingen. The pilot is tasked to approach and attack a ground target on an approach profile fixed with way points. In the course of his task, the pilot detects an enemy aircraft ready for takeoff. Fig. 9 shows how the pilot attacks this enemy together with the ground target. The green part shows the flight path over ground, the blue part the altitude profile. Beside the runway, the locations of the ground defence are shown. In addition to the time mark the flight path also contains the point where the target was in the sight and the moment of weapons release.

Fig. 10 shows an air-to-air mission involving helicopter fighting. Operational simulations were performed to test the Alpha Jet's capabilities and possibilities for helicopter fighting. Fig. 10 is an example of these investigations, giving an impression of a dogfight without further comment. A number of parameters were varied in these studies: the Alpha Jet mission tactics, the type, configuration, the helicopter's weapons, just to mention a few of the major parameters.

In these air-to-air missions the opponent airborne target was faded in the simulator visual system. This airborne target was controlled either by preprogrammed automatic control commands or manually from the instructor station or by a "paper pilot", that is, a sophisticated computer program to simulate human pilot behaviour in a combat situation. As the Alpha Jet HUD did not have a special air-to-air mode at that time, we used a simple air-to-air mode which was developed and programmed for the HUD in the simulator. Fig. 11 presents an example of this air-to-air mode. In the background, the simulator visual system can be seen. On the left-hand side below the pipper, the enemy helicopter can be seen.

An important task which was performed recently on the Alpha Jet simulator concerned the development of the exact specification for the air-to-air mode of the Alpha Jet. This is described in the following section.

4. HUD - AIR-TO-AIR MODE

The task read as follows: The HUD-symbology of the Alpha Jet for the air-to-air mode must be optimized. For this purpose, various symbology versions were studied taking into account different flight profiles (against helicopters and fast aircraft). The symbology versions were proposed and studies were conducted with pilots from different institutions. Only the Alpha Jet simulator in the Dornier simulation laboratory could be used for these studies since it was the only simulator that met all requirements.

The new air-to-air symbology was to be optimized and specified under the typical boundary conditions for air-to-air tracking task and fight against airborne targets. For this purpose, various attack profiles for slow and fast airborne targets with the associated data were developed. The symbol optimization requires a long tracking phase, and the initial positions for the simulator runs were chosen accordingly.

It would exceed the scope of this paper to go into details of these tests. However, before presenting the results, one technical detail will be pointed out as it concerns the advantages of simulation also for training purposes: to obtain optimum results from comparative assessments, modifications in the symbology had to be possible swiftly and at any time (also ON LINE). Therefore, a declutter box was installed at the interface of the display generator which made possible the variation of 8 display elements during simulation (ON LINE) and the presentation of nine different symbology versions. This box comprises a number of switches by means of which individual symbols or symbol groups (e.g. pitch ladder) can be switched on and off.

Furthermore, a joystick is installed which makes it possible to shift at random all symbols or symbol groups in x- and y-direction at a speed of 17 mrad/sec. When the symbol is in its definite place, the position is "frozen" by releasing the joystick and then exactly documented. In this way, the exact specification was available at the end of the tests without any optical surveying of the image content.

The results of the development is as follows:

The symbology presented in fig. 11 was the starting point, as it was the only symbology at that time which had been "flown" in tests. The proposals developed on paper relied heavily on the existing HUD symbology for navigation and air-to-ground missions. Fig. 12 shows one of these proposals. The individual versions differ only in some minor details. The principal difference is a pronounced increase in the amount of in-

formation, above all, the display of the pitch attitude is very evident. However, simulation tests showed that this led to problems with the dynamic image portions.

Figs. 13-16 illustrate further stages in the development of display image content up to the final specification. These pictures are self-explanatory and require no detailed description. The most obvious change in fig. 13 is the dashed line between gun circle and pipper. This bullet line vector is used for better aiming and calculation of movements.

In addition to many minor details the main issue of the pitch and roll lines remained to be solved. While fig. 13 shows only the pitch attitude, fig. 14 presents only the roll lines. Two versions were laid down in the specification which will undergo flight testing. They are the version with roll lines (fig. 15) and an otherwise identical version with pitch lines (fig. 16).

So far the examples on operational simulations are given as they were performed on the Alpha Jet simulator in the Dornier simulation laboratory. All of these simulator runs which concern the testing of new approach methods, tactics, instruments, control elements or new weapons always involve also the pilot's training in these matters, the so-called operational training. This fact and the close cooperation with pilots from the German air force led to activities, discussions and experience concerning the use of simulators in operational training in the flying unit or simulator-assisted flight-tactical training.

These aspects are described in the last section.

5. OPERATIONAL TRAINING IN THE DEUTSCHE LUFTWAFFE

Operational training with simulators, that is the operational flight and tactics trainer is described in the following as it is used in flying units. And naturally, the subject is restricted to the simulation of combat aircraft.

Fig. 17 shows the individual phases of pilot training. Since we deal with flight and tactics simulators in tactical wings, we only refer to the last phase, formation training (= operational training in the flying unit). And partially, weapons system training will also be approached.

Fig. 18 shows the flight and tactics simulators in service with the tactical wings. All simulators are jointly designated OFTT = Operational Flight and Tactics Trainer, a far too ambitious designation in view of what is done with these simulators. After a long service life and in view of the rapid pace of development in simulator technology, the F 104 G simulators are outdated and, accordingly, little used. The F-4F and RF-4E simulators are of a more recent date and have thus better and more advanced equipment, but they too are not used to a satisfactory degree.

Currently, there are the simulators for the new Alpha Jet and Tornado aircraft generation. They are discussed in the following. Within the discussion on new simulators for the operational training on the Alpha Jet and Tornado, a paper on flight simulation in advanced formation training was presented to high-ranking officers from the Federal Ministry of Defence.

At first, the pilot's attitude towards simulators was presented. An attempt was made to express the essential statements from the multitude of pilot opinions in the form of catchwords, shown in fig. 19. Naturally, these statements which are based on the AGARD Advisory Report No. 159, reference literature listed therein, and on studies in the German air force, are very rough and generalizing. But the main trends are evident:

- The civilian sector makes much better use of simulators than the military sector. There are indications that civilian flight simulators are used ten times as much as simulators in the tactical wings. And there are clues that the actual ratio is even worse in the military sector.
- The USA seems to be more simulator-minded than Europe. There are certainly objective (equipment) and subjective (psychological reservations) reasons for this which, however, will not be pursued further in this context.
- The last line in fig. 19 represents the summary. The so-called flight and tactics simulators are used only as procedure trainers. But for this purpose, procedure trainers would be sufficient and no expensive full mission trainers would be required.

Then, the discussion on the usefulness of flight simulators in general was presented. Fig. 20 reveals the principal reasons in favour of simulators. They are conventional, well-known reasons with emphasis on safety and economic aspects. But another aspect is of paramount importance here: namely the fact that an aircraft is not the ideal training equipment. There are, without any doubt, aspects where a simulator is superior to an aircraft, namely with respect to the demonstration possibilities and training conditions including learning control. These aspects are rarely taken into consideration let alone used. This necessarily originates criticism.

The principal reasons for criticism to flight simulators are shown in fig. 21. First of all there is the rapid and one might say even brisk development in simulator technology. This point is even substantially strengthened by the fact that there is very little coordination worldwide. This applies in particular to the military sector. Each organization makes its own procurements, and, as a result of extreme requirements, breaks new ground where a high development risk is involved. Combined with the goal of getting total solutions the systems become more and more complex and expensive. Inevitably, this leads to the next sources of criticism (fig. 21), namely the inefficient use and inappropriate equipment of simulators. This in turn causes anger and frustration on the part of the pilots and provokes a counterreaction. The other component of psychological reservation is based on the fact that pilots regard the simulator as competitor, as a threat to real flying.

A rough outline of the situation in flight simulation in general and now in particular with respect to the situation of new generation flight simulators in the German air force has been given. As a rule, these simulators were procured as a copy of the aircraft without prior definition of their operational role. Following earlier procurements, this led to the fact that the simulators for the Alpha Jet were outfitted with equipment too expensive and inappropriate. Alpha Jet simulators for example are equipped with an unnecessary motion system but have no head up display and simulator visual system which are very important for air-to-ground missions. As a result, a Luftwaffe-internal evaluation draws the conclusion that "the Alpha Jet is not suited for flight-tactical training as the systems offers no possibilities in this field".

The design of the Tornado simulator, on the other hand, has received much more attention, even though its equipment becomes very expensive. It seems as if there are high expectations with respect to its operational possibilities which simply cannot be satisfied by a simulator. Thus, on the basis of a cost/benefit ratio such a simulator seems to become far too expensive. And in addition, some systems of this particular simulator still involve development risks. The simulator visual system in particular caused and is still causing unjustifiable high costs.

As a result of this analysis, short-term measures were proposed which are shown in fig. 22. These measures will not be described in detail. Response to these measures and to the report as a whole was positive and actions were taken to improve the situation. Yet, only one report has been presented in the meantime "Simulator-assisted Operational Training" by the agency for studies and training of the Bundeswehr which remains in the old cliches.

The following conclusion must be drawn: In practice, there is very little application for and consequently hardly any experience in operational training with simulators.

6. REFERENCES

- 1 H. Friedrich
Simulation bei der Entwicklung des Alpha Jet
Vortrag gehalten auf dem DGLR-Symposium "Angewandte Flugwissenschaften bei der Entwicklung des Alpha Jet" am 24. September 1981 in Darmstadt
- 2 H.-J. Munser, U. Knab
Optimierung der HUD-Symbologie für die Betriebsart Luft/Luft mit dem Dornier-Alpha Jet-Simulator
Dornier-interner Bericht, Sept. 1983
- 3 H. Friedrich
Flugsimulation in der Verbandsausbildung
Vortrag gehalten im Bundesministerium der Verteidigung am 3. Februar 1982 in Bonn
- 4 -
Fidelity of Simulation for Pilot Training
AGARD Advisory Report No. 159, December 1980
- 5 G. Trapmann, V. Zimmer
Simulatorgestützte fliegerisch-taktische Ausbildung
Luftwaffeninterner Bericht, Juni 1983

DORNIER
Dornier Alpha Jet Simulator



Fig. 1 Dornier Alpha Jet Simulator

DORNIER
Simulator-Subsystems

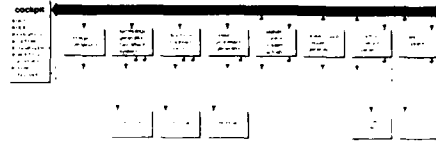

Fig. 2 Simulator Subsystems



Fig. 3 Simulator with Visual System



Fig. 4 Visual System with poor Visibility

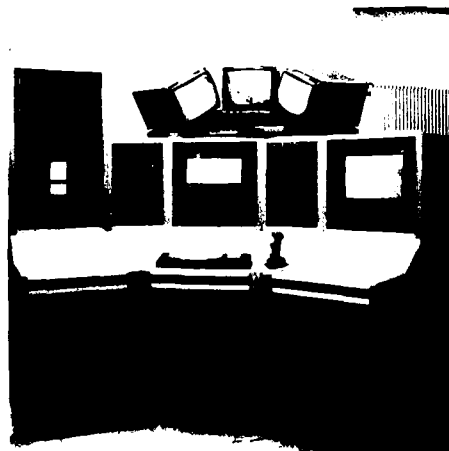

Fig. 5 Instructor and Control Console

DORNIER
Air-to-Ground Mission

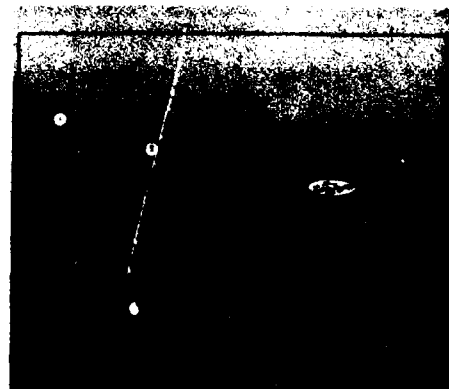

Fig. 6 Air-to-Ground Mission

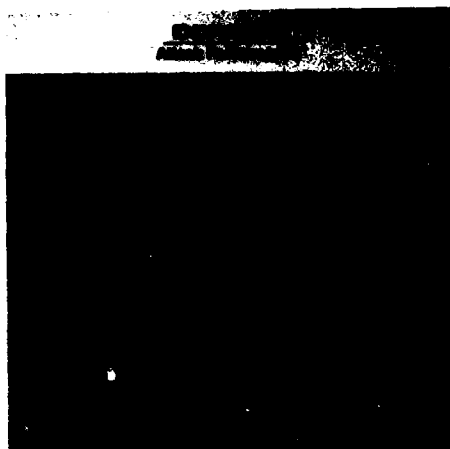

Fig 7 Attack Performance

DORNIER
Hits in the Aircraft by S/A Gunfire

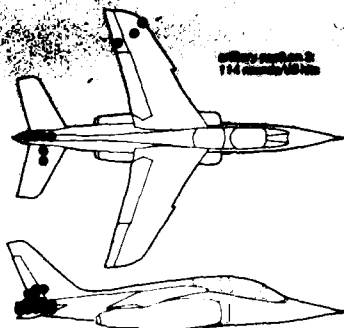

Fig 8 Hits in the Aircraft S/A Gunfire

DORNIER
Attack against tactical movable Target

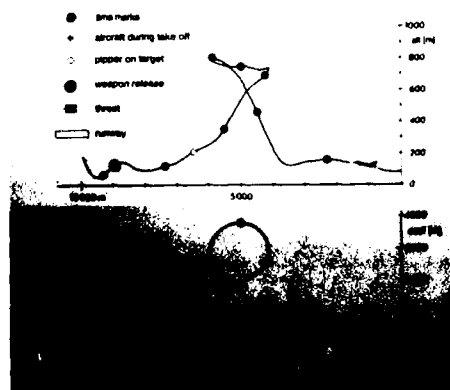

Fig 9 Attack against tactical/movable Target

DORNIER
Helicopter Fighting

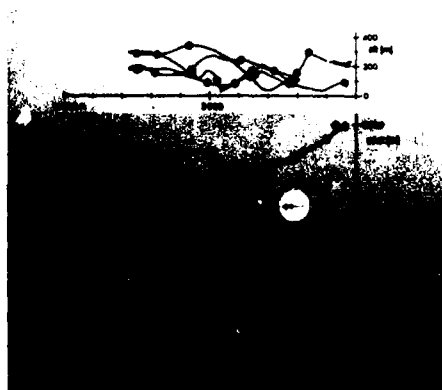

Fig 10 Helicopter Fighting

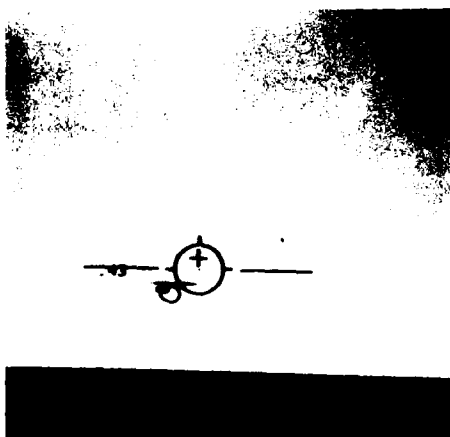

Fig 11 Air-to-Air Mode in Helicopter Fighting

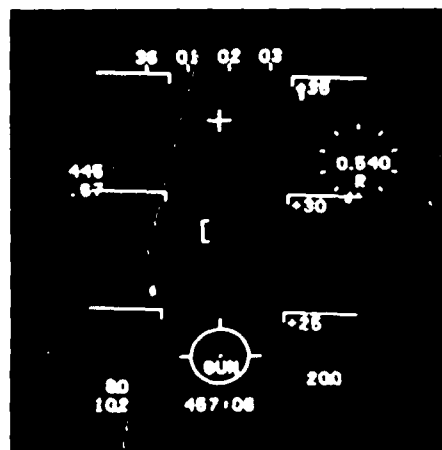

Fig 12 HUD Air-to-Air Mode, Beginning

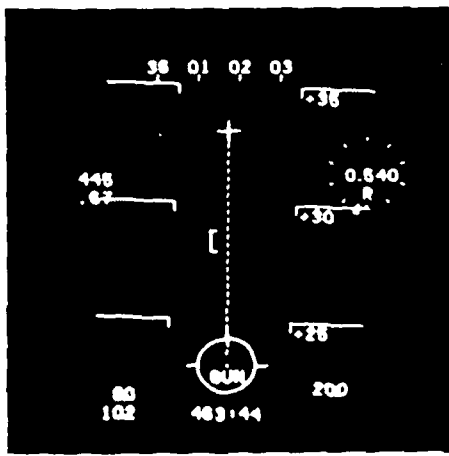

Fig. 13 HUD Air-to-Air Mode, Phase 2

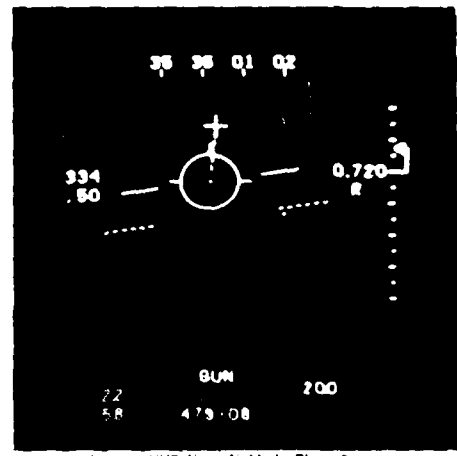

Fig. 14 HUD Air-to-Air Mode, Phase 3

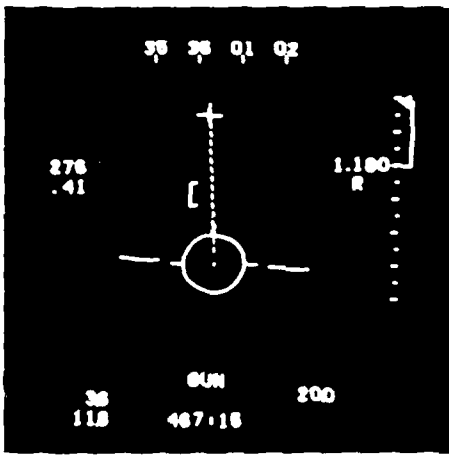

Fig. 15 HUD Air-to-Air Mode, Result A

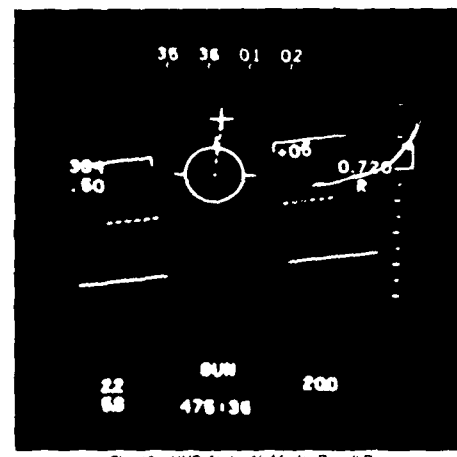

Fig. 16 HUD Air-to-Air Mode, Result B

DORNER
Phases of Pilot Training

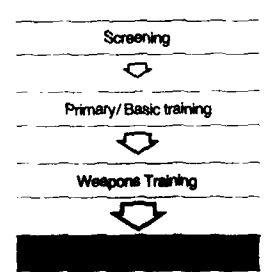

Fig. 17 Phases of Pilot Training

DORNER
Operational Training with Flight Simulators

- OFFT - F 104 G
- F-4 F
- RF-4 E
- [Redacted]
- [Redacted]

Fig. 18 Operational Training with Flight Simulators

DORNIER
Flight Simulators Critized by the Pilots

	civil		military	
	Europe	USA	Europe	USA
general condition of the simulator	excellent			
pilots attitude	positive			
flight performance handling qualities	good			
cost	accepted with some reservation	looked upon as important		
weight	criticism against level of view resolution	accepted		
reliability	very good in the whole spectrum			

Fig. 19 Flight Simulators Critized by the Pilots

DORNIER
Arguments in Favour of the Simulator

- safety
- savings of time and costs
- fuel economy
- independence from weather
- better possibilities for demonstration
- better training conditions
- reduction of environmental disturbance
- extension of flight time
- reduction of the number of required airplanes

Fig. 20 Arguments in Favour of the Simulator

DORNIER
Deficiencies in Flight Simulator Training

- Deficiencies in Specification and Procurement
- Improperly Equipment
- Improperly Use
- Unflexible Use
- No objective Measure for Training Effectiveness

Fig. 21 Deficiencies in Flight Simulator Training

DORNIER
Short-termed Actions

- Simulator - Mission Planning
- Simulator - Instructor
- Training Effectiveness Tests
- Air Force Simulation Laboratory
- Enlarge the Operational Training
 - Weapon Systems Familiarization
 - Head Down Mission
 - Head Up Mission
- Connection with Manoeuvring Ranges
- Research with Simulator Visual Systems
- Working Group for Short-termed Actions
- Working Group for Future Actions

Fig. 22 Short-termed Actions

A METHOD FOR AIRCRAFT SIMULATION
 VERIFICATION AND VALIDATION DEVELOPED
 AT THE UNITED STATES AIR FORCE
 FLIGHT SIMULATION FACILITY

by
 G.R. Anderson, 1LT, USAF
 Simulation Engineer
 6520 Test Group
 Air Force Flight Test Center
 Edwards, California
 93523-5000
 USA

SUMMARY

The flight simulators at the United States Air Force Flight Test Center (AFFTC), Aircraft Flight Simulation Facility (AFSF) are primarily used for performance and flying qualities studies. These high-fidelity, real-time simulators are used as an engineering tool during the flight development of new or modified aircraft. Emphasis is placed on fully developing, verifying and validating a simulation before the actual aircraft begins flight testing. The flexibility, accuracy and ease with which the facility's method of verification and validation can be learned and implemented are a few of its advantages. This is demonstrated by the number of simulations which have been developed using it. The F-16 A/B, B-1B, Shuttle, F-15 C/D, AFTI (Advanced Fighter Technology Integration) F-16, F-16 C/D, and the T-46 are examples of simulations presently operational at the facility which were developed using the AFSF's method.

The philosophy of developing a simulation before flight test allows the most to be learned about the aircraft before testing begins. The "test smarter" approach taken at the AFFTC requires that aircraft simulations be built quickly and be used to make flight testing more efficient and safer. The method for verifying and validating simulations used at the AFSF assures that these requirements are fulfilled.

BACKGROUND

THE FACILITIES

The AFSF has three computer systems that are used for simulation support. The computer systems consist of:

- a) Six Perkin-Elmer 8/32 central processing units (CPUS): dedicated to the development and real time operation of the simulation software.
- b) Two Sel 32/55 CPUs: utilized for non real-time analysis and checkout of an aerodynamic database.
- c) AD 10/PDP 11 complex

Five cockpits are available. Four cockpits are fixed based and one is a moving base. Any cockpit can, with a minimum of effort, support multiple simulations. All computers and cockpits are maintained and supported by personnel at the AFSF.

THE MODULAR APPROACH

Employing a standard naming convention and emphasizing a modular approach to software coding has proven to be a beneficial tool in simulation development at the AFSF. The modular approach has facilitated the speedy development of simulations. In addition, it allows software changes to be performed in minutes. It also makes it possible for more than one engineer to work on a particular part of the aircraft simulation at one time. For example, numerous engineers can be coding the flight control system (FCS) modules of an aircraft, each engineer working on a different axis. A module is determined according to what section of the aircraft model it represents. The FCS is generally modularized with respect to the control axes. The flight control code usually consists of PITCH, ROLL, YAW and SERACT (servo actuators) modules. Likewise, the airframe code is divided into modules. The module COEF, calculates the aerodynamic coefficients and the LOOKUP module is responsible for performing the table

lookup on the aerodynamic data. The FCS and airframe modules are simulation specific and will vary from aircraft-to-aircraft.

Code which is common to many aircraft simulations has also been appropriately modularized. These common simulation modules are placed in a user library, (Standard Modules). The Standard Modules, as with the simulation specific modules, are logical collections of software. Code to generate user defined test maneuvers, such as singlets and doublets, is found in the module PTI. The standard module AUTPIM allows an aircraft simulation to be placed in a trim condition automatically, as an initial condition. The equations of motion are placed in two modules within the library. PEOM calculates rotational equations of motion and TEOM calculates translational equations of motion. All atmospheric calculations are done in the module ATMOS. Placing software common to many aircraft in the Standard Modules has aided in eliminating redundant code and conserving computer memory. Standard Modules can be utilized by any simulation simply by referencing it in the formation of the simulation real-time task.

SIMULATION DEVELOPMENT

The development of a simulation consists of accurately modeling the characteristics of a specific aircraft. At the AFSF, the development of a simulation is performed in steps. The airframe and the FCS of a simulation are analyzed, coded, implemented and verified independently of each other. Verifying; confirming the accuracy of the implementation of the aircraft model, occurs as each part of the simulation is developed. When all portions of the simulation are complete and verified, end-to-end checks are performed. End-to-end checks consist of comparing the developed simulation to the actual aircraft flight test data or other simulations of that aircraft. This comparative process is what is referred to as validation of the simulation at the AFSF. Validation assures that the airframe and the flight control system are operating properly together and that the implemented model correctly represents the actual aircraft.

The airframe portion of a simulation is defined by the aerodynamic data, coefficient equations, atmospheric calculations and equations of motion. Standard module software for the rotational equations of motion (REOM), the translational equations of motion (TEOM) and atmospheric calculations (ATMOS) is used in the development of this portion of the simulation. The aerodynamic data and coefficient calculation software must be coded for each particular airframe.

Analyzing the aerodynamic data is the first and major step in the development of the airframe simulation. Aerodynamic data arrives at the AFSF in various forms. The AFSF has dealt with aerodynamic data that has come into the facility on magnetic tapes, punch cards, plots, and tabular listings. The wide variety of simulations built and the number of different "customers" the AFSF deals with means that the facility needs to be flexible enough to accept aerodynamic data in virtually any format. An aerodynamic data base editing program, DBEDIT, was developed, to fulfill this requirement. DBEDIT resides on a SEL 32/55 computer and has evolved over the years to become a fairly versatile data base editing program. Aerodynamic data can be entered into DBEDIT manually through a keyboard, on magnetic tapes, punch cards or through the use of a digitizer.

DBEDIT is also used during simulation development to analyze and modify aerodynamic data. In order to make use of DBEDIT the amount of aerodynamic data required to model the desired aircraft and it's specified tasks must be determined, considering the amount of computer memory allocated for the aircraft simulation. A review of the aerodynamic package will determine the number of derivatives in the package and their effect on the aerodynamics of the aircraft. The aerodynamic derivatives that are considered to have negligible effects on the aerodynamics of the aircraft may be disregarded. Next the engineer must determine of what argument each derivative is a function (e.g. angle of attack, angle of sideslip, control surface deflection). Breakpoints for each aerodynamic derivative are then identified according to these arguments. A DBEDIT "argument file" can now be created. The argument file contains the names of each aerodynamic derivative, the arguments the derivative is a function of and the names and values for each breakpoint. When the creation of the argument file is complete aerodynamic data can be entered into a DBEDIT "aero file" corresponding to the defined argument file. Once the aerodynamic data is entered into the DBEDIT aero file it is possible to manipulate the data as required. An aero file can be created or modified whenever the program DBEDIT is activated.

Once the aerodynamic data base has been defined the next step in the simulation development is the task of writing the software to calculate the total aerodynamic

coefficients. An aerodynamic derivative function lookup and coefficient calculation routine must be built. These routines are referred to as the software subroutine modules LOOKUP and COEF. LOOKUP manipulates the aerodynamic data in real-time according to the aircraft flight condition and outputs the appropriate derivative value. COEF uses the derivatives calculated in LOOKUP along with the appropriate values from ATMOS, REOM and TEOM to calculate the total aerodynamic coefficients. Both the COEF and LOOKUP modules are coded at the AFSF and utilize subroutines from the standard library.

The FCS provides pilot inputs to the control surfaces and usually augments stability and controllability. The development of a simulation FCS is a crucial step in building an aircraft simulation. The simulation FCS is developed using a FCS schematic. Each FCS axis is identified. The components within each axis are reduced to mathematical functions and then coded. Since the computers used at the AFSF are digital machines, analog FCSs can only be approximated by the digital FCS simulation. Much effort is devoted to correctly modeling an analog FCS. Importance is placed on accurately modeling the frequency response of each component of the FCS. When modeling a digital control system, emphasis is placed on running the simulation at the same sampling rate as the actual aircraft FCS computer.

After each FCS axis has been coded the modules are placed in the real-time task. The FCS modules are arranged in the real-time task according to the order in which they affect aircraft response. (e.g. The elevator stick force is an input to the PITCH module and elevator deflection is an output of the SEPACT module). In general this order is PITCH - ROLL - YAW - SERACT.

METHOD OF VERIFICATION

AIRFRAME STATIC CHECKS

Static checks are a multi-step process to insure 1) there are no errors in coding in the subroutines LOOKUP, COEF, ATMOS, REOM, and TEOM and 2) that the aerodynamic data has been implemented correctly. Since ATMOS, REOM, and TEOM are Standard Modules and used by every simulation their correctness is well established and it is not necessary to perform static checks on these modules unless they were modified for some unique requirement. It is the practice within the AFSF for one engineer to write the LOOKUP and COEF software and another engineer to write the airframe static checks. This practice adds another level of certainty to the aerodynamic mathematical model and allows conceptual errors on the part of the primary programmer to be discovered and corrected early in the airframe development.

The first step in the verification process is to ensure that no errors were introduced into the aerodynamic data when the data were entered into DBEDIT. A Calcomp plotter is utilized at the AFSF to produce check plots of the aerodynamic data. Incorrect data points or other obvious errors usually cause a discontinuity in the aerodynamic data plots and are therefore easily identified. These points can then be corrected through the use of the DBEDIT modify routine. This is done before the aerodynamic database is implemented on the real-time simulation.

Airframe static checks are written using a DBEDIT aero file listing. Several flight conditions and configurations within the flight envelope of the aircraft being simulated are chosen. The conditions are also chosen to cover a wide range of aerodynamic derivative values. The value of each derivative at each flight condition is manually looked up in the DBEDIT listing. Using the derivative values and the equations for the coefficient calculations, the coefficient values for each flight condition are also manually calculated. The values for the derivatives and the coefficients are recorded and will, in the next step, be compared to the real-time airframe simulation.

Comparing the manually calculated static checks to the real time calculated values takes place once the real-time simulation has been loaded into the Perkin-Elmer's central processing units and initiated. Each set of flight conditions selected for the static checks is entered into the airframe simulation as an initial condition. In this mode the computers will calculate the values for the airframe at the given condition. The initial condition mode can be thought of as freezing the simulated aircraft at a prescribed point in the flight envelope. In this mode the aerodynamic derivative and coefficient values calculated by the real-time simulation are checked against the DBEDIT static checks. The computer calculated values and the manually calculated values using the DBEDIT listing should agree to at least four or five significant figures. A value that doesn't agree is first re-checked against the DBEDIT listing. If an error was made in preparing the static checks, the new value is compared to the real-time value. If

the values still do not correspond or if the DBEDIT value was correct from the beginning the appropriate software module is reviewed. Errors in the code or errors in implementing the derivative and coefficient calculations are corrected and the static checking process begins again. It is possible, but not probable to have the airframe software check out on the first try. It is not important that the values check out right away. However, it is important that the errors discovered during static checking are corrected and that the static checks are run until all values agree. Any errors undiscovered at this point will complicate the rest of the verification and validation process; very often resulting in many hours spent looking for the source of the error.

FLIGHT CONTROL SYSTEM STATIC CHECKS

The FCS static checks perform the same function as the airframe static checks. As with the airframe, FCS static checks are written by one individual and performed on the real-time simulation by another individual. Static checks are utilized to check that the AFSF interpretation of the FCS is coded correctly. All switches, gradients, gains and limiters are checked out during the FCS static checks, as represented by figure 1. Switches are tested by setting inputs on all possible combinations and checking the switch output. Checking several points on a gradient assures it's code is functioning properly. Inputs are entered into gains and the outputs checked. By saturating limiters, their effectiveness is checked. If the FCS static checks reveal an error it becomes necessary, as with airframe checks, to isolate the problem in the code, correct it and run the static checks again.

Static checks are only verifying the code that has been written in-house to model the airframe and the FCS. These checks will reflect only that the airframe and FCS mathematical models, as interpreted in the AFSF, are implemented correctly. The static checks will not reveal an incorrect airframe or FCS interpretation. Whether or not interpretation of the aerodynamic package or the FCS is correct is revealed through the process of dynamic checking.

DYNAMIC CHECKS

The purposes of dynamic checks are to:

- 1) Checkout operation of simulated dynamic items, such as, filters and integrators.
- 2) Assess impact of non-intentional time delays.
- 3) Perform an overall check that all simulator parts work together.

Both the airframe and the FCS of a simulation are subject to dynamic checks.

The airframe dynamic checking procedure begins with the DBEDIT aero file and the flight conditions chosen for the static checks. The aero file and the flight conditions are inputs to a non-real time batch simulation program, LINDMUTH. LINDMUTH is a five degree-of-freedom simulation. The program's primary purpose is to provide accurate time histories of short stability maneuvers for verification of flight simulator stability and control characteristics. The program allows two dimensional lookups on the aerodynamic data, a variable frame time and a large amount of flexibility in setup. LINDMUTH produces time histories for surface deflections, rates, accelerations, angles of attack and angles of sideslip. The LINDMUTH program has been used at the AFSF since 1967 and it's validity is well established. The program calculates solutions to the equations of motion to determine aircraft accelerations. The accelerations include the three rotational and the vertical and lateral translational accelerations.

Once the LINDMUTH program is setup, a test maneuver, such as a doublet, is applied to a control surface of each axis of the simulation. This is repeated for every chosen flight condition. Each flight condition is determined in the same manner as the flight conditions in the static checking portion of the verification. LINDMUTH produces time histories, which are plotted on a CALCOMP plotter and scaled to exactly match the outputs of the real-time strip charts. In order to insure no human error occurred in setting up LINDMUTH the output of LINDMUTH is qualitatively checked for reasonableness. If an error is discovered during the LINDMUTH runs, the LINDMUTH setup and aerodynamic data are examined. The nature and location of the error will determine the action to be taken. Corrections are made as necessary and LINDMUTH is run again. This process is continued until an accurate set of LINDMUTH plots result as represented by figure 2.

The next step is to compare the LINDMUTH plots with the real-time simulation dynamic output.

The same maneuver used for the LINDMUTH runs is performed on the real-time simulation at exactly the same conditions. Time histories will be generated on the strip charts. The real-time strip charts for the example in figure 2 can be seen in figure 3. By overlaying the LINDMUTH runs onto the real-time runs the accuracy to which the real-time airframe has been implemented can be determined. In order to be considered fully verified the time histories must agree to within one percent. Clearly, some engineering judgement comes in to play here. If the time histories do not agree the real-time code and aerodynamic data are evaluated and corrected for errors as necessary. It is important to emphasize that the code is not manipulated, in any way, to make it appear to respond correctly.

FCS dynamic checks are performed to verify that the time-dependent elements within the FCS are performing properly. Through the use of a frequency response analyzer it is possible to check every time dependent element in a FCS. The frequency response analyzer (FRA) is an instrument which can measure the magnitude and phase response of a system in the frequency domain. There are two parts to the analyzer 1) a generator which provides a signal of known amplitude and frequency in the form of $A \sin(\omega t)$, and 2) a correlator which determines the amplitude and phase angle of the output signal. The signal being supplied by the generator is input into a time-dependent FCS element; a filter for example. The correlator then measures the amplitude and phase angle of the signal through the filter and the plotter connected to the system plots out the corresponding Bode plot. Analytically calculated Bode plots are compared to the FRA generated plots. The FRA generated Bode plots are analyzed to check that the cut-off frequencies and phase angle relationships correspond to the analytically calculated plots. If correlation is confirmed, the filters have been implemented correctly and are functioning properly.

When both the airframe and FCS have been verified independently it is then necessary to verify that they work properly together. Both the airframe and FCS are activated in the real-time simulation. A test maneuver, such as a doublet, is input to a FCS axis. The reaction of the corresponding surface is observed, usually by outputting the result to a strip chart. If the aircraft, as a system, operates as expected the simulation is deemed verified.

METHOD OF VALIDATION

Validation is the method by which the simulations at the AFSF are determined to be accurate models of the actual aircraft they represent. The manner in which a simulation is validated depends upon what resources are available. Flight test data, time histories from other simulation facilities results, and pilot comments are a few of the more common ways simulations are validated.

If a simulation is of an aircraft that is not in production or is not yet undergoing flight testing, the task to validate it is more difficult. Simulations at the AFSF of this type rely on time histories from other simulation facilities for comparison. Although comparison of AFSF simulation results to other simulation facilities results does not prove that either simulation is correctly modeled it does help to eliminate some errors which may have been overlooked, since the probability of two organizations making the same error is small. Experience has shown that comparing results between two independent simulations has found and lead to the elimination of errors in both simulators. This method of simulation validation is also applied to simulations of aircraft currently in existence and being flight tested.

It is common to use pilot comments about how a particular simulation flies with respect to the actual aircraft in the validation process. Pilot comments are used as a qualitative method of simulation validation. It is extremely nice to know that the aircraft simulation, which has been under development for the last six months, "feels" like the actual aircraft.

A simulation of an aircraft that is in the process of flight testing is also validated by data from actual flight test missions. This can be in the form of time histories or stability and control derivatives. The flight conditions flown during a test mission can be duplicated on the simulation. The flight test data and the simulation data are then compared. If the comparison shows little difference the simulation is a valid model of the actual aircraft. If the data does not agree, the simulation is reviewed to find out what bits of information it's missing. Occasionally

it is a matter of updating aerodynamic data or a FCS that has not been modified since the original design and tests which generated it. It is a relatively simple task at this point to incorporate actual flight test data into a simulation. Once this is accomplished the sections which have been updated or modified are verified. The simulation is then compared to the flight test results again and if it agrees the simulation is validated. A simulation can be modified, verified and validated numerous times throughout the flight test program of the aircraft it simulates. This allows the simulation to continue to grow along with the test aircraft.

CLOSING REMARKS

The method of verification and validation used at the AFSF is beneficial in that it allows simulations to be continually modified to meet the changes of the actual aircraft during flight testing. Often this translates into overall cost savings and safer flight testing. It also allows the AFPTC to develop baseline simulations, which might be used in the future to investigate accidents, or begin flight tests on a slightly modified version of the previous aircraft.

FLIGHT CONTROL SYSTEM COMPONENTS
(STATIC CHECKS)

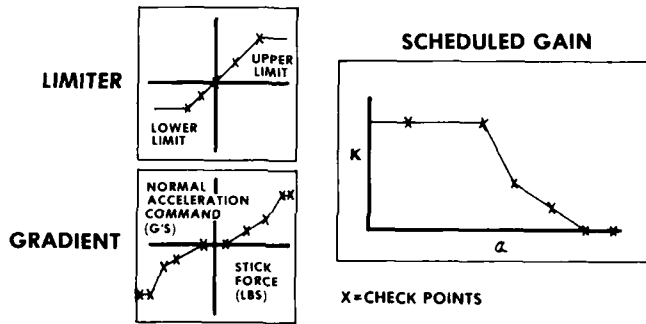

FIGURE 1

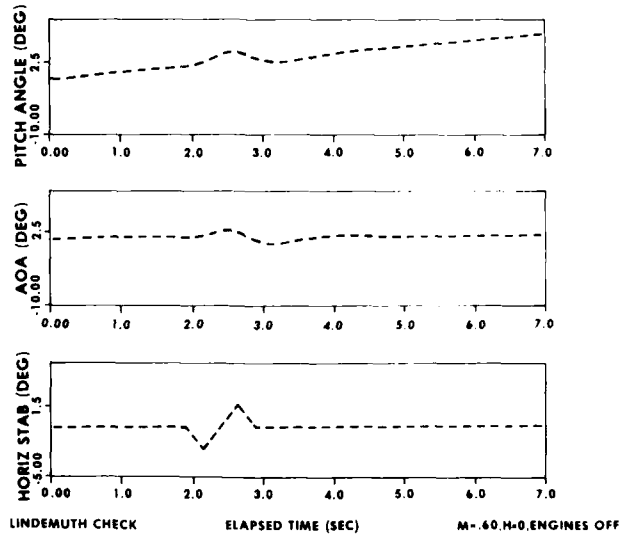
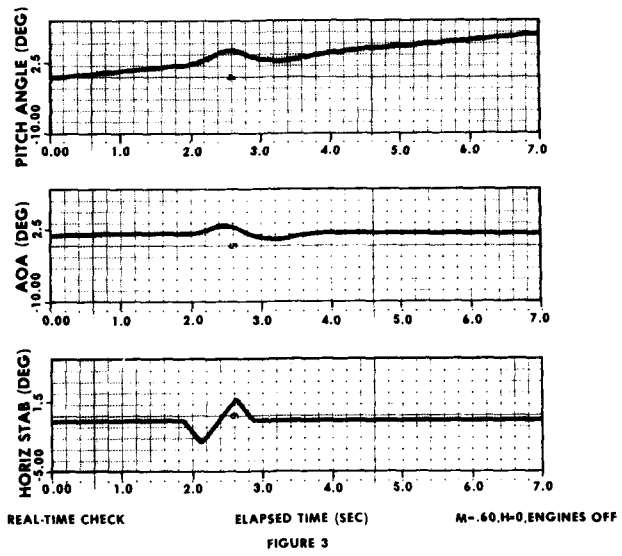

FIGURE 2



CORRELATION BETWEEN FLIGHT SIMULATION AND PROCESSING OF FLIGHT TESTS
BASED ON INERTIAL MEASUREMENTS

by
A.M.H. Nieuwpoort, J.H. Breeman, L.J.J. Erkelens and P.J.J. van der Geest
National Aerospace Laboratory NLR,
Amsterdam, The Netherlands

SUMMARY

The use of dynamic flight test techniques as a way of obtaining accurate aerodynamic information with a reduction in flighttime has been applied increasingly during the last decade. A strong stimulus herefore has been the improved accuracy of the flight test instrumentation.

Furthermore developments in flight simulation as a tool for training and research and development have been substantial.

Both topics have been and are still subject of research at the National Aerospace Laboratory, NLR. One of the aircraft mathematical models, which are available for the NLR's moving base flight simulator is that of the Fokker F-28 transport aircraft. This model has been composed of data derived from conventional methods (windtunnel + stationary flight tests).

Starting in 1977 several flight test programmes with this aircraft have been performed using both conventional and dynamic techniques based on inertial measurements. The use of inertial sensors in flight testing implies, that specific forces and body rates are determined, which are directly employed in the so-called flight path reconstruction procedure. This procedure uses the equations of motion governing the vehicle's flight. After this step aerodynamic model identification can take place.

In flight simulation more or less the opposite process occurs. From the available aerodynamic and engine model specific forces and angular accelerations can be computed. Then the equations of motion can be integrated in order to determine the flight path.

Consequently there is a strong similarity in the way flight test results are processed and reduced in order to obtain aerodynamic information and the way simulations are executed using a given model.

Some examples of manoeuvres are presented as performed in the simulator and in flight.

LIST OF SYMBOLS

$\{\vec{A}\}$	kinematical acceleration vector	m/s ²
$\{\vec{a}\}$	specific force vector	m/s ²
α_p	angle of gross thrust vector w.r.t. the y-direction of the body axes	rad
$\{\vec{b}\}$	arm length vector of thrust	m
C_D	drag coefficient	
C_{D_0}	zero lift drag coefficient	
C_{D_α}	change in drag coefficient due to angle of attack	1/rad
C_{D_q}	change in drag coefficient due to dimensionless pitch rate	
$C_{D_{\delta_e}}$	change in drag coefficient due to elevator deflection	1/rad
C_L	lift coefficient	
C_{L_0}	lift coefficient at zero angle of attack	
C_{L_α}	change in lift coefficient due to angle of attack	1/rad
C_{L_q}	change in lift coefficient due to dimensionless pitch rate	
$C_{L_{\dot{\alpha}}}$	change in lift coefficient due to dimensionless rate of change in angle of attack	
$C_{L_{\delta_e}}$	change in lift coefficient due to elevator deflection	1/rad
C_r	rolling moment coefficient	
C_m	pitching moment coefficient	
C_{m_0}	pitching moment at zero angle of attack	
C_{m_α}	change in pitching moment coefficient due to dimensionless pitch rate	
$C_{m_{\dot{\alpha}}}$	change in pitching moment coefficient due to dimensionless rate of change in angle of attack	
$C_{m_{\delta_e}}$	change in pitching moment coefficient due to elevator deflection	
C_n	yawing moment coefficient	
C_x	specific force coefficient along x-body axis	
C_y	specific force coefficient along y-body axis	
C_{y_w}	side force coefficient in flight path axes system	

C_z	specific force coefficient along z-body axis	
\bar{c}	mean aerodynamic chord	m
D	drag force	N
$[\vec{f}]$	aerodynamic and propulsive forces	N
$[\vec{g}]$	gravitational acceleration vector	m/s ²
g	acceleration due to gravity	m/s ²
i_p	angle of gross thrust vector w.r.t. the x-direction of the aircraft body axes	rad
I_x, I_y, I_z, I_{xz}	moments and product of inertia about the body axes	kgm ²
L	lift force	N
L_R	rolling moment	N
$[\vec{M}]$	moment vector	Nm
M	pitching moment	N
M	Mach number	
m	aircraft mass	kg
mc	centre of mass	
N	yawing moment	N
p	roll rate about the x-body axis, including Coriolis and earth curvature effects	rad/s
P	roll rate about the x-body axis	rad/s
q	$\frac{1}{2} \rho V A^2$	Pa
q	pitch rate about the y-body axis, including Coriolis and earth curvature effects	rad/s
Q	pitch rate about the y-body axis	rad/s
r	yaw rate about the z-body axes, including Coriolis and earth curvature effects	rad/s
R	yaw rate about the z-body axis	rad/s
S	wing area	m ²
t	time	sec
u	velocity component along the x-body axis	m/s
v	velocity component along the y-body axis	m/s
w	velocity component along the z-body axis	m/s
V	ground speed	m/s
VA	airspeed	m/s
X_G	gross thrust	N
X_D	momentum drag	N
Y_W	lateral force in the flight path axes frame	N
α	angle of attack	rad
$\dot{\alpha}$	rate of change in angle of attack	rad/sec
β	side slip angle	rad
$\dot{\beta}$	rate of change in side slip angle	rad/sec
γ	flight path angle	rad
θ	pitch angle	rad
δ_e	elevator deflection	rad
δ_h	stabilizer deflection	rad
δ_a	aileron deflection	rad
δ_r	rudder deflection	rad
ρ	density of air	kg m ⁻³
ϕ	roll angle	rad
ψ	bank angle	rad
χ	course angle	rad
χ_G	track angle	rad
ψ	heading	rad
$[\psi]$	inertia tensor	kgm ²
<u>Subscripts and superscripts</u>		
B	aircraft body axes	
F	flight path axes	
T	thrust body axes	
A	with respect to the surrounding air	
G	with respect to the ground	
i	denotes regression coefficients	
~	denotes skew-symmetric matrix	

The following systems of axes are relevant (Figures 1, 2 and 3)

1. Inertial reference frame. (O_I, X_I, Y_I, Z_I) This is a Newtonian frame with the origin situated in the earth centre. The Z_I -axis coincides with the rotation axis of the earth, positive in the direction of the North Pole. The X_I -axis lies in the equatorial plane perpendicular to the Z_I -axis. The Y_I -axis is perpendicular to the $X_I Z_I$ plane positive according to a right-handed system.
2. Aircraft carried vertical axes frame. (O_V, X_V, Y_V, Z_V) This frame has its origin in the mass centre of the aircraft. The Z_V -axis coincides with the local g-vector. The X_V -axis is perpendicular to the Z_V -axis positive to the North. The Y_V -axis is perpendicular to the $X_V Z_V$ plane positive to the east. (Figure 1)
3. Body axes frame. (O_B, X_B, Y_B, Z_B) This is an aircraft-fixed reference frame with the origin in the mass centre. The X_B -axis coincides with the centreline of the fuselage and is defined positive in the forward direction. The Z_B -axis is situated in the plane of symmetry perpendicular to the X_B -axis and

positive pointing downward. The y_B -axis is perpendicular to the $x_B z_B$ -plane, positive in the right-hand wing tip direction. (Figure 2)

4. Flight path axes frame. ($0_P, X_P, Y_P, Z_P$) This is a system attached to the aircraft in the mass centre. In contrast with the body axes the x_P -axis coincides with the velocity vector of the mass centre. The y_P and z_P axes are defined as in the body axes frame. (Figure 3)

1 INTRODUCTION

The availability of a mathematical model representing the aerodynamics of the aircraft in an accurate way is very important, because of the use of such a model in flying qualities studies. Furthermore the design of automatic flight control systems requires a good knowledge of the stability and control characteristics. Finally, the aerodynamic model supplies the necessary data for programming the flight simulator. Since the beginning of aircraft development, flight testing has been an inevitable, although expensive activity of aircraft manufacturers to determine and to certify the performance and flying qualities of their products. The flying qualities can be determined from the stability and control derivatives. These are usually derived from steady state tests by analysing free oscillations with the time vector method and by means of response matching using an analog computer.

However, the benefits of determining the stability and control characteristics by means of non-stationary flight test methods incorporating dynamic manoeuvres (Reference 1) became more and more apparent due to:

1. The application of more sophisticated and accurate flight instrumentation systems.
2. the enormous growth in digital computing capacity.
3. the benefits of the developed data processing methods.

As a consequence of these developments it became possible to obtain a larger and more accurate set of data in a relative short period of time for the speed range of interest.

Also as a result of the advance of the computer technology the range of flight simulation has been extended tremendously. Due to the large increase in memory capacity and computation speeds it became possible to simulate real time complex systems with large bandwidths digitally. Until then simulation of flight control systems, landing gear reactions, actuators etc. could only be realised on an analog computer in connection with the digital computer (hybrid computation).

Also the assumption of linearity was required, when studying phenomena analytically with the aid of mathematical tools. However, due to the higher levels of computer power it became feasible to implement complete non-linear models.

In figure 4 the three main tools are depicted, which conventionally are used in the aircraft design process viz. theory, windtunnel and prototype testing.

However, in the last decade because of the above mentioned reasons the simulator emerges as a powerful fourth design tool, in which a number of subsystems can be integrated with the pilot directly in the loop.

Furthermore there is a tendency to transfer more critical parts of the certification programme of a new aircraft to the simulator. This directly results in a requirement to have an accurate aerodynamic model. Therefore the simulator model based upon windtunnel data has to be updated as soon as possible with accurate flight test information. This in return calls for flight test methods, which are able to meet these requirements.

Finally because both windtunnel measurements and flight testing have their specific limitations the simultaneous data sets can be used as an improved data base for new aircraft designs.

2 FLIGHT TEST ASPECTS

2.1 General

The instrumentation system required for flight tests incorporating dynamic manoeuvres must be of a higher level than usually is employed with the conventional methods.

Four independent sensor systems can be distinguished:

1. Inertial measurement system.
2. Air-data measurement system including vanes to measure the aerodynamic angles.
3. Engine parameter system.
4. Control surface position system.

During the non-stationary flight test programme performed in 1977 with the Fokker F-28 (Reference 2) the inertial measurement system consisted of a unit especially developed by the NLR. However, the appearance of highly accurate and commercially available strapped-down inertial reference systems made it possible to replace this unit in subsequent tests by a Honeywell IRS (Inertial Reference System).

In order to keep the transformation of the accelerations to the actual centre of mass as small as possible the inertial measurement system has to be placed in the proximity of the centre of mass position.

The outputs of the air-data measurement system consist of very accurate values of static pressure and impact pressure.

During the test flights a trailing cone was used as the static pressure source. Prior to the actual measurements flights are performed to determine the position error correction.

The data resulting from the above-mentioned sensor systems are acquired and stored on magnetic tape by a computer controlled data acquisition system, which also controls the modes of the sensor systems.

It must be mentioned that in addition to the above described sensor systems also angle-of-attack and side slip vanes are installed. The output of the angle of attack vane, corrected and well calibrated, is used as a very helpful piece of information in the flight path reconstruction procedure. In contrary to the angle of attack the side slip angle vane output is directly employed in the reconstruction because of the problems related to the measurement of the side wind component.

The first steps in the actual processing of the data (preprocessing) consist of the application of instrumental corrections, conversion to engineering units, computation of additional parameters from the data, corrections due to position error, time lags and centre of mass shifts.

2.2 Data processing and analysis

For the analysis of accurate flight test data obtained from inertial measurements, the NLR has developed a set of computer programmes, which are based upon a two-step method. In reference 3 this procedure has been described. Schematically it is indicated in figure 5.

In the first step the so-called flight path reconstruction is performed, which yields an accurate reconstruction of the state of the aircraft from the flight measurements recorded.

This process is based upon the use of the flight test measurements both inertial and with respect to the local atmosphere (air data system) and the kinematic equations of motion governing the rigid body modes. The aerodynamic angle of attack can be computed from time histories of reconstructed parameters. If no side wind is present the same applies for the side slip angle.

In contrast to other techniques the aerodynamic model is not used hereby for improving the state estimate. The accurate flight test measurements eliminate the necessity for this. Due to the statistical nature of the measurement errors use is made of the well-known Kalman filtering and smoothing techniques to obtain smooth time-histories of the non-dimensional aerodynamic coefficients as well as of the state variables.

As can be noticed from figure 5 these results are used as input data for the second step of the analysis. Herein the stability and control derivatives are determined from:

1. the aerodynamic coefficients
2. the aircraft state variables
3. the control variables.

The stability and control derivatives are computed by means of an equation error method (regression analysis (Reference 4)). The regression algorithm is based upon the theory of the solution of linear least squares problems with the aid of Householder transformations and Givens rotations. A computer programme has been developed by the NLR in which this algorithm is used. This programme is indicated by the name PIAS, which is the acronym for: "Processing of dynamic manoeuvre measurements with an Interactive Adaptive System".

The separation of the trajectory reconstruction and the parameter identification process PIAS makes it possible to select and evaluate aerodynamic models in a flexible way. After specifying the time interval, (or combination of time intervals), the model structure and (optional) a priori values for the aerodynamic parameters, a complete model calculation is performed within a few seconds. Hereby use is made to a great extent of computer graphics creating a direct interactive communication between computer and analyst. More detailed information about the programme can be found in reference 5.

Also typical for the equation error procedure is, that for each of the six rigid body degrees of freedom of the aircraft a mathematical model must be postulated for the aerodynamics.

It is well known, that one of the most difficult problems in regression analysis is the mathematical modelling of the physical phenomenon. If the model covers the aircraft aerodynamics sufficiently, the parameter, which exhibit high sensitivity in the measurements and which are not correlated with other parameters, are identified accurately. The final test with respect to the accuracy of the determined parameters is the ability of this model to predict accurately through simulation the responses of flight manoeuvres not used in the identification process.

In the aerodynamic modelling the analyst has three important tools at his disposal to construct and validate the assumed model viz.:

1. Theoretical background based on the equations for the airflow around the aircraft.
2. Information from windtunnel tests.
3. Statistical tools following from the regression analysis.

3 SIMULATION ASPECTS

3.1 General

The moving base flight simulator at the NLR consists of five major parts:

1. Visual system, which is generated by a solid terrain model. Via a camera a picture of the terrain is projected on a monitor in front of the pilot. Through wide angle collimating techniques it is possible to provide visual scenes at infinity.
2. Motion system, which is a four degree of freedom system in pitch, yaw, roll and heave. Hydrostatic actuators are employed.
3. Cockpit lay out. Depending on the type of investigation a single seat fighter or a side by side cockpit can be selected.
4. Control loading system, which is of the electro-hydraulic type.
5. Software and mathematical models.

The simulation software runs on a Perkin-Elmer 3200 Multi Processor System, which was expanded with a 3220 system incorporating an ARINC 429 interface. As result of the parallel processing during real-time computations three calculation streams of the simulation process are present, which communicate interactively through interfaces.

Mathematical models of different kind of aircraft are present, among which the Fokker F-28 (reference 6).

Although the fidelity of the complete simulation is strongly dependent on the fidelity of the individual five topics the mathematical model is the least subjective part. This is because also off line analysis can be performed using the same real-time simulation software.

The characteristics of the vehicle laid down in the various submodels are embedded in the simulation software package which has a modular structure. The most important submodels related directly to the aircraft are:

1. Aerodynamic model
2. Engine model
3. Model of the atmosphere, wind and gust
4. Landing gear model
5. Flight control system model
6. Navigation model.

A very important benefit of software is the ease with which changes can be made. However, as result of this flexibility large efforts are required to assure the quality of the software. Because software errors easily can ruin a simulation and consequently the results extracted from it, the NLR has developed a number of specific tools to protect the whole process (Reference 7).

3.2 Data processing

As can be noticed from figure 6 in which the simulation process has been depicted schematically, integration of the equations of motion results in a flight path reconstruction. Just like in the flight data processing here also smooth time histories of coefficients and state variables become available.

Therefore use can be made of processing software which also is employed in flight test analysis. As already has been mentioned the extraction of the derivatives from flight test data is accomplished with the PIAS programme.

However, it also can be used in simulator studies, which are tailored to define optimal control inputs for parameter identification.

Because in simulation a priori knowledge of the aerodynamics already is available excursions through the complete model are defined in a more exact manner than is possible in flight. Furthermore because the aerodynamic and thrust models are mathematically defined, this knowledge can be used directly in the formulation of the form of the regression function applicable to a particular manoeuvre (Reference 8).

4 CONTROL INPUTS

In order to obtain well-conditioned data, it is important to have suitable input signals. They must be able to excitate the aircraft rigid body modes in such a way that accurate identification of the aerodynamic parameters can take place. Here a number of manoeuvres will be indicated, which appear useful for the identification of stability and control derivatives. A distinction has been made between manoeuvres intended for the identification of the longitudinal derivatives and manoeuvres suitable for the identification of the lateral-directional derivatives.

The criteria for the evaluation of the proposed manoeuvres can be formulated as follows:

1. The manoeuvres shall be simple to perform by a pilot without requiring exceptional skill or on an automatic flight control system.
2. The accuracy of the estimated stability and control derivatives as determined from processing the measured data, shall be satisfactory.

The following manoeuvres are considered for identification of the longitudinal derivatives:

1. sinusoidal elevator oscillation
2. multi step elevator input
3. level turn manoeuvre
4. pull up/push over manoeuvre
5. untrimmed flight manoeuvre.

The level turn and pull up/push over manoeuvre are performed in order to achieve a decoupling between the variables δ and q . In motions resulting from elevator inputs these variables are so highly correlated, that identification of the individual derivatives is very difficult.

The untrimmed flight manoeuvre is carried out to make it possible to separate the contributions of the stabilizer and the elevator control parameters.

The following manoeuvres have been considered for the identification of the lateral-directional derivatives:

1. steady side slips
2. aileron step manoeuvres
3. rudder doublets

In the 1977 flight test programme only sinusoidal elevator pulses were executed for identification of the longitudinal derivatives. The shape of this input was determined by the Department of Aerospace Engineering of the Delft University of Technology and consisted of a two period control movement. The frequency of the pulses was dependent on the configuration and Mach number.

As already has been indicated in particular the flight simulator is a very useful instrument for the determination of suitable control inputs. It allows an investigation under controlled conditions, whereby use is made of realistic aerodynamic models. Moreover because the pilot is part of the loop the practicability of the various control input signals can be evaluated. Therefore prior to the actual flight tests of 1977 the manoeuvres were evaluated and tested on the flight simulator with the F-28 models incorporated. According to the test pilots these exercises contributed to a reduction of the learning time during the real flight tests.

However, subsequent studies revealed, that in particular for the identification of the longitudinal derivatives a single manoeuvre could not yield all parameters with acceptable accuracy.

Therefore the investigations were continued both on the ground and in flight. Reference 9 describes a study performed on the flight simulator. Herein sets of both longitudinally and lateral-directional manoeuvres are determined which were able to give accurate stability parameters. The sets of manoeuvres proposed in this study were flown in a short flight test programme with the F-28, which confirmed the simulator results.

5 FLIGHT PATH RECONSTRUCTION

The flight path of an aircraft can be described mathematically by the equations of motion over a rotating spherical earth with respect to an inertial frame with origin in the earth centre. Only three equations describing the translations of the mass centre are required for trajectory analysis. If motions about the centre of mass are considered also the moment equations of motion have to be taken into account.

Expressed in body axes the force equation can be represented in matrix form as:

$$\begin{bmatrix} \dot{a} \\ \dot{t} \\ \dot{m} \end{bmatrix}^B = \begin{bmatrix} \dot{A} \\ \dot{m} \\ \dot{g} \end{bmatrix}^B \quad (5.1)$$

in which:

- $[\vec{a}]_{mc}^B$: specific forces resulting from accelerometers attached to the body axes frame (IRS) and transformed to the centre of mass
- $[\vec{f}]^B$: aerodynamic and propulsive forces expressed in body axes
- $[\vec{\Lambda}]_{mc}^B$: kinematical acceleration vector
- $[\vec{g}]^B$: acceleration vector due to gravity along the body axes.

$[\vec{\Lambda}]_{mc}^B$ consists of the kinematical accelerations along the body axes, the corresponding transport accelerations and the centripetal and coriolis accelerations due to the curvature and rotation of the earth respectively.

Expression (5.1) represents a non-linear set of differential equations with respect to time. In principle these equations can be integrated, when either the specific forces and angular velocities or the aerodynamic and propulsive forces are known. The former occurs during flight test measurements. The latter situation appears for real-time simulations.

The flight path reconstruction in the data processing in fact is based on the integration of (5.1) employing the measured time histories of the specific forces, angular rates, airspeed and height with respect to a reference altitude. The specific forces and angular rates result directly from the inertial measurement unit, whereas the air-velocity and height increment or decrement can be derived from the air data measurement system.

However, the measurements are corrupted with errors and the exact initial conditions necessary for the start of the integration are not known. Therefore, statistical procedures are required to attenuate the effect of these errors on the time histories of the state variables. In the data processing the well-known Kalman filtering and smoothing technique is employed.

Mathematically the flight path reconstruction in flight simulation is less complex than is the case for flight test data. Uncertainties in the measurands and atmospheric conditions are not present because gust, wind and noise can be incorporated in the simulation at discretion.

In contrast to the flight data processing, there is no weighting required for the computation of the initial condition.

In flight simulation it can be computed exactly from the models, the selected configuration and flight condition. However, it is obvious, that the computed initial condition can never be more accurate than the aerodynamic and thrust models will allow.

The determination of the initial condition comprises the first step in the integration procedure. Therefore it is important to determine the initial condition in such a way that no drift occurs from the steady state condition, when the integration of the equations of motion starts (operate mode).

This is achieved by using a Newton-Raphson algorithm, which based on the determination of the Jacobian iteratively computes the initial condition calling the routines employed in the operate mode in the same sequence.

In the flight-path reconstruction both for simulation and flight data processing the most important variables to be reconstructed are the velocities u , v and w both inertial and with respect to the local atmosphere along the body axes, the body rates p , q and r and the Euler angles θ , ψ and ϕ . From the reconstructed velocities the angle of attack can be determined according to:

$$\alpha(t) = \arctg \left[\frac{w(t)}{u(t)} \right]_{ATR} \quad (5.2)$$

Also the slip angle can be found from:

$$\beta(t) = \arcsin \left[\frac{v(t)}{V(t)} \right]_{AIR} \quad (5.3)$$

In the data processing of the flight test measurements these angles are computed by a weighting of the velocities resulting from the inertial measurement system and velocities resulting from the air-data measurement system in the flight path reconstruction procedure. Because the former is earth referenced, whereas the latter is measured with respect to the surrounding air, the wind vector is incorporated through the equality:

$$[\vec{V}]_{INERT} = [\vec{V}]_{AIR} + [\vec{V}]_{WIND} \quad (5.4)$$

Obviously the determination of the angle of attack for steady state conditions can also be based on the above described procedure, because with respect to the reconstruction of the air trajectory the steady state is only a special case of the more general unsteady state.

In ground-based simulation the wind can be selected and through (5.4) coupled to the equations of motion.

If wind is present distinction must be made between the flight path with respect to the ground and with respect to the surrounding air as is indicated in Appendix A.

Obviously the requirement to estimate accurately the aerodynamics from flight manoeuvres with various aircraft configurations and flight conditions directly calls for an accurate thrust computation. The main difficulty here is to specify which parts contribute to drag and which parts contribute to thrust. Often this is a matter of definition. For the F-28 the thrust is computed from calibrated engine data, employing measured values of atmospheric parameters, static air temperature and pressure and a number of engine pressures and turbine rotation speeds.

For simulation purposes in fact the same thrust model can be used. However, here the throttle position must be translated to a specific turbine or compressor rotation speed or directly into an exhaust

pressure ratio.

The difference with respect to the thrust between simulation and flight data processing can be indicated as follows. In the former the thrust components are required in order to obtain the specific forces necessary for the integration of the equations of motion, whereas in the latter the thrust components are subtracted from the specific forces in order to isolate the aerodynamic contributions (Figure 5 and 6).

The thrust computation consists of two parts viz.

1. Determination of the gross thrust X_G
2. Determination of the ram drag X_D .

The gross thrust or exhaust momentum thrust has its working line in a body-fixed axes frame, which deviates from the aircraft body axes by having a different origin and small offset angles (Appendix A).

The ram drag or intake momentum drag is a drag force and consequently it is situated in the flight path axes frame with respect to the surrounding air.

6 CALCULATION OF THE AERODYNAMIC COEFFICIENTS

The specific forces are measured by the accelerometers in the IRS in a body axes frame. After transformation to the actual centre of mass position they represent the simultaneous effect of the aerodynamic and propulsive forces:

$$[\ddot{a}]_{mc}^B = \frac{[\ddot{f}]}{m}^B = \frac{[\ddot{f}]_{AERO}^B}{m} + \frac{[\ddot{f}]_{PROP}^B}{m} \quad (6.1)$$

Usually the aerodynamic forces are expressed in the flight path axes system w.r.t. the local atmosphere according to:

$$\frac{[\ddot{f}]_{AERO}^B}{m} = \frac{1}{m} \begin{matrix} F_A \\ \begin{bmatrix} -D \\ Y_W \\ -L \end{bmatrix} \end{matrix} \quad (6.2)$$

Also the ram drag is available in the same flight path axes system as:

$$[\ddot{f}]_{PROP_k}^B = \begin{matrix} F_A \\ \begin{bmatrix} -X_D \\ 0 \\ 0 \end{bmatrix} \end{matrix} \quad (6.3)$$

The gross thrust is expressed in a thrust body axes system. Conversion to the aircraft body axes gives:

$$[\ddot{f}]_{PROP_G}^B = L_{BT} \begin{matrix} T \\ \begin{bmatrix} X_G \\ 0 \\ 0 \end{bmatrix} \end{matrix} \quad (6.4)$$

in which L_{BT} is the transformation matrix from the thrust axes system to the body axes system (see Appendix A).

Furthermore, a transformation is required for the gross thrust vector from the body axes to the flight path axes frame w.r.t. the air through the aerodynamic angles α and β , which corresponds to:

$$\begin{bmatrix} X \\ Y \\ Z \end{bmatrix}_G^F = L_{FB_A} \begin{bmatrix} X \\ Y \\ Z \end{bmatrix}_G^B = L_{FB_A} L_{BT} \begin{bmatrix} X_G \\ 0 \\ 0 \end{bmatrix}_T = L_{FT_A} \begin{bmatrix} X_G \\ 0 \\ 0 \end{bmatrix}_T \quad (6.5)$$

Finally also the specific forces must be converted to the flight-path axes frame according to:

$$[\ddot{a}]_{mc}^F = L_{FB_A} \begin{matrix} + F_A \\ + B \\ [\ddot{a}]_{mc} \end{matrix} \quad (6.6)$$

Substituting and writing explicitly in the aerodynamic forces it follows:

$$\begin{bmatrix} -D \\ Y_W \\ -L \end{bmatrix}_{\frac{1}{m}}^{F_A} = L_{FB_A} \begin{bmatrix} a_{x_{mc}}^B \\ a_{y_{mc}}^B \\ a_{z_{mc}}^B \end{bmatrix}^B - L_{FT_A} \begin{bmatrix} X_G \\ 0 \\ 0 \end{bmatrix}_T + \begin{bmatrix} X_D \\ 0 \\ 0 \end{bmatrix}_{\frac{1}{m}}^{F_A} \quad (6.7)$$

The aerodynamic force coefficient C_D , C_Y , C_L are obtained through division of (6.7) by the instantaneous dynamic pressure and wing area.
For a particular manoeuvre these force coefficients generally represent non-steady state conditions.

Writing (6.7) in scalar form results in:

$$\begin{aligned} C_D &= -C_X \cos \alpha \cos \beta - C_Y \sin \beta - C_Z \sin \alpha \cos \beta + \frac{(x_G \cos \beta \cos (\alpha + i) - x_D)}{q \cdot S} \\ C_{Y_W} &= -C_X \cos \alpha \sin \beta + C_Y \cos \beta - C_Z \sin \alpha \cos \beta - \frac{x_G \sin \beta \cos (\alpha + i)}{q \cdot S} \\ C_L &= C_X \sin \alpha - C_Z \cos \alpha - \frac{x_G \sin (\alpha + i)}{q \cdot S} \end{aligned} \quad (6.8)$$

in which

$$C_X = \frac{m}{q \cdot S} \cdot a_{x_{mc}}^B \quad C_Y = \frac{m}{q \cdot S} \cdot a_{y_{mc}}^B \quad C_Z = \frac{m}{q \cdot S} \cdot a_{z_{mc}}^B$$

and

$$[\vec{a}]_{mc}^B = \begin{bmatrix} a_{x_{mc}}^B \\ a_{y_{mc}}^B \\ a_{z_{mc}}^B \end{bmatrix} \quad (6.9)$$

On the other hand the $[\vec{a}]_{mc}^B$ vector also results from the kinematics expressed in body axes according to:

$$[\vec{a}]_{mc}^B = [\vec{A}]_{mc}^B - [\vec{g}]^B \quad (6.10)$$

in which:

$$\begin{aligned} [\vec{A}]_{mc}^B &= \begin{bmatrix} A_{x_{mc}}^B \\ A_{y_{mc}}^B \\ A_{z_{mc}}^B \end{bmatrix} = \begin{bmatrix} \dot{u} \\ \dot{v} \\ \dot{w} \end{bmatrix} + \tilde{\omega}_B * \begin{bmatrix} u \\ v \\ w \end{bmatrix} \\ \tilde{\omega}_B &= \begin{bmatrix} 0 & -r_B & q_B \\ r_B & 0 & -p_B \\ -q_B & p_B & 0 \end{bmatrix} \quad \text{with } \vec{\omega}_B = \begin{bmatrix} p_B \\ q_B \\ r_B \end{bmatrix} \quad [\vec{V}] = \begin{bmatrix} u \\ v \\ w \end{bmatrix} \\ [\vec{g}]^B &= L_{BV} \begin{bmatrix} 0 \\ 0 \\ g \end{bmatrix} \end{aligned} \quad (6.11)$$

Here V represents the ground speed, g is the acceleration due to gravity along the local vertical. The rotary motion vector $\vec{\omega}_B$ includes effects due to the curvature and rotation of the earth. L_{BV} is the transformation matrix including the Euler angles (Appendix A).

When only interest exists in the trajectory of the aircraft which e.g. is the case in performance calculations the aircraft can be considered as a concentrated mass point. In that case the motion is often expressed in flight path axes according to:

$$[\vec{a}]_{mc}^{FG} = L_{FB_G} [\vec{a}]_{mc}^B = \begin{bmatrix} a_{x_{mc}}^{FG} \\ a_{y_{mc}}^{FG} \\ a_{z_{mc}}^{FG} \end{bmatrix} = \begin{bmatrix} \dot{v} \\ 0 \\ 0 \end{bmatrix} + \tilde{\omega}_P * \begin{bmatrix} v \\ 0 \\ 0 \end{bmatrix} - L_{WV_G} \begin{bmatrix} 0 \\ 0 \\ g \end{bmatrix} \quad (6.12)$$

in which: V : ground speed

$$\tilde{\omega}_P = \begin{bmatrix} 0 & -r_P & q_P \\ r_P & 0 & -p_P \\ -q_P & p_P & 0 \end{bmatrix} \quad \text{with } \vec{\omega}_P = \begin{bmatrix} p_P \\ q_P \\ r_P \end{bmatrix} \quad (6.13)$$

L_{FB_B} and L_{WV_G} are transformation matrices w.r.t. the ground (Appendix A).

For a constant wind vector it can be shown that if coriolis and earth curvature effects are neglected, it applies:

$$[\ddot{a}]_{mc}^A = L_{FB}^A [\ddot{a}]_{mc}^B = \begin{bmatrix} \dot{V}_A \\ 0 \\ 0 \end{bmatrix} + \dot{\omega}_F * \begin{bmatrix} V_A \\ 0 \\ 0 \end{bmatrix} - L_{WV}^A \begin{bmatrix} 0 \\ 0 \\ \dot{B} \end{bmatrix} \quad (6.14)$$

From this the α and β variables w.r.t. surrounding air can be derived according to:

$$\begin{bmatrix} p_F \\ q_F \\ r_F \end{bmatrix}_A = L_{FB}^A \begin{bmatrix} p_B \\ q_B \\ r_B \end{bmatrix} + \begin{bmatrix} -\dot{\alpha} \sin \beta \\ -\dot{\alpha} \cos \beta \\ \dot{\beta} \end{bmatrix} \quad (6.15)$$

in which:

$$q_{FA} = -\frac{a_{ZF}^A}{V_A} \quad (6.16)$$

$$r_{FA} = \frac{a_{XF}^A}{V_A}$$

In assessing flying qualities also the motion about the centre of mass must be considered. The moment equations of motion usually are expressed in the body axes frame because then the inertia tensor remains constant. Also here the moments consist of contributions due to aerodynamic and propulsive forces which can be represented as:

$$[\dot{M}]^B = [\dot{M}]_{AFRO}^B + [\dot{M}]_{PROP}^B \quad (6.17)$$

If only the geometrical part of the propulsive forces to $[\dot{M}]^B$ is considered (thus excluding any aerodynamic effects), then it can be written in matrix form:

$$[\dot{M}]_{PROP}^B = \tilde{b} * \left([\dot{f}]_{PROP}^B + L_{FB}^A [\dot{f}]_{PROP}^A \right) \quad (6.18)$$

in which:

$$\tilde{b} = \begin{bmatrix} 0 & -b_z & b_y \\ b_z & 0 & -b_x \\ -b_y & b_x & 0 \end{bmatrix} \quad \text{with } [\tilde{b}] = \begin{bmatrix} b_x \\ b_y \\ b_z \end{bmatrix} \quad (6.19)$$

$[\tilde{b}]$ represents the coordinates of the thrust vector in a body axes reference frame. It is assumed, that both the gross thrust and ram drag vector have the same origin.

$[\dot{M}]$ results also from the kinematical relations.

If a rigid body is considered it follows:

$$[\dot{M}]^B = [\psi] * \dot{\omega}_B + \dot{\omega}_B * [\psi] * \dot{\omega}_B \quad (6.20)$$

which expanded in scalar form for a symmetric aircraft lead to the well known expressions:

$$\begin{aligned} L_R &= I_X \cdot \dot{p}_B - I_{XZ} \cdot (\dot{q}_B + p_B \cdot q_B) - (I_Y - I_Z) \cdot q_B \cdot r_B \\ M &= I_Y \cdot \dot{q}_B - I_{XZ} \cdot (r_B^2 - p_B^2) - (I_Z - I_X) \cdot r_B \cdot p_B \\ N &= I_Z \cdot \dot{r}_B - I_{XZ} \cdot (\dot{p}_B - q_B \cdot r_B) - (I_X - I_Y) \cdot p_B \cdot q_B \end{aligned} \quad (6.21)$$

The aerodynamic moment coefficients can be derived by division of (6.21) through the instantaneous dynamic pressure, wing area and length unit.

In contrast to the force equations the parts in the angular accelerations and velocities representing the effect of the curvature and rotation of the earth can be neglected.

As can be noticed from (6.21) accurate results, directly depend on the accuracy of the momentary mass and inertia moments and products. Because the dimensions of the F-28 are such, that a determination of these quantities is not possible experimentally, the required data were computed through bookkeeping of the individual components.

7 CORRELATION BETWEEN FLIGHT TEST AND SIMULATOR MANOEUVRES

In the simulation process the aerodynamic coefficients C_D , C_Y , C_L , C_ξ , C_m and C_n result from the aerodynamic model, which usually is non-linear. For a given aircraft configuration they are a function of a number of state and control variables such as:

important because of the following reasons:

1. Flight control systems are becoming more complex and will be more integrated within the aircraft design process.
2. There is a tendency to perform parts of the certification programme of prototype aircraft on a simulator.
3. Flight management computers make use of aerodynamic information. Consequently the effectiveness of these systems depend on the fidelity of these data.
4. The use of more accurate data in training simulators also gets more and more interest, because of the trend of transferring more critical functions from the real aircraft to the simulator.

9 REFERENCES

1. Gerlach, O.H. The determination of stability derivatives and performance characteristics from dynamic manoeuvres
Delft University of Technology, Department of Aerospace Engineering, Delft
Report VTH-163, 1971
2. Nieuwpoort, A.M.H., Determination of performance and stability characteristics from dynamic longitudinal manoeuvres with the Fokker F-28 transport aircraft.
Breeman, J.H. Summary of test results.
NLR TR 83126 C, 1983, Restricted
3. Mulder, J.A., Analysis of aircraft performance, stability and control measurements
Jonkers, H.L., AGARD Lecture series no. 104 on parameter identification, 1979
Horsten, J.J.,
Breeman, J.H.,
Simons, J.L.
4. Draper, N.R., Applied regression analysis
Smith, H. J. Wiley and Sons, 1966
5. Doekes, G., Description of program PIAS
Simons, J.L. NLR Memorandum WN-78-006
6. Nieuwpoort, A.M.H., Simulation of the Fokker F-28 on the NLR moving base flight simulator
Vermeulen, W.G. NLR TR 78062 C, 1978, Restricted
7. Marsman, A.P.L.A. Flexible and high quality software on a multi processor computer system controlling a research flight simulator
NLR MP 85061 U, 1985
8. Nieuwpoort, A.M.H. Summary of results derived from stability and control measurements in non-stationary flight with the Fokker F-28 Mk 6000 aircraft
NLR Memorandum VA-82-011 C, 1981, Restricted
9. Erkelens, L.J.J., Flight simulator validation of a series of flight test manoeuvres concerning their utility with respect to the determination of the stability and control derivatives
v.d. Geest, P.J. NLR Memorandum VS-82-019 C, 1982, Restricted

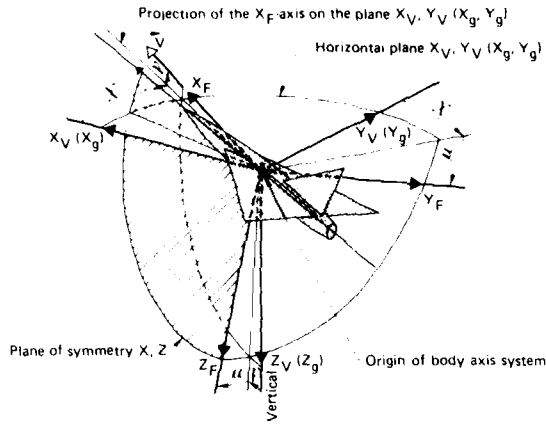

Aircraft carried vertical earth axis system (X_V, Y_V, Z_V)
 Flight path axis system (X_F, Y_F, Z_F)

Fig. 1 Orientation of the flight path axis system relative to the aircraft carried vertical earth axis system

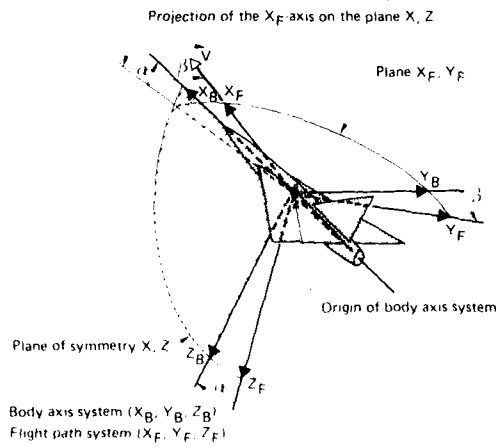
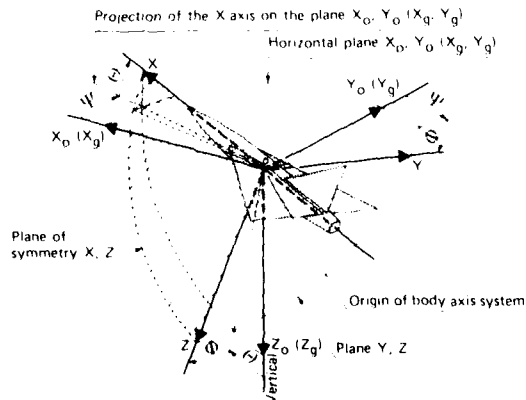

Fig. 2 Orientation of the aircraft velocity with respect to the body axis system



Aircraft carried vertical earth axis system (X_V, Y_V, Z_V)
 Body axis system (X_B, Y_B, Z_B)

Fig. 3 Orientation of the body axis system with respect to the aircraft carried vertical earth axis system

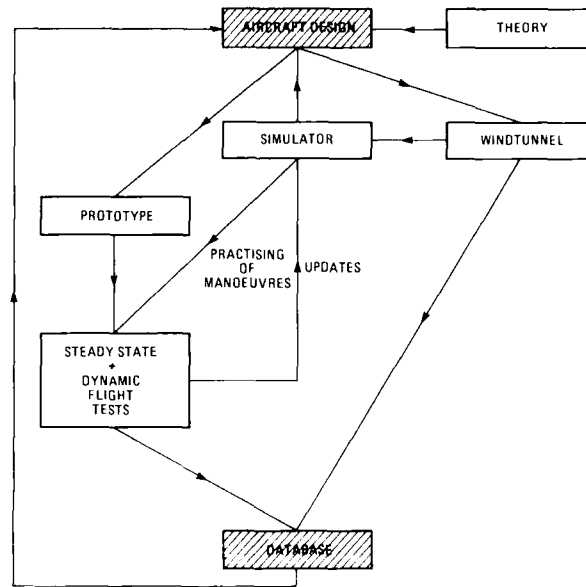

Fig. 4 Survey of design process

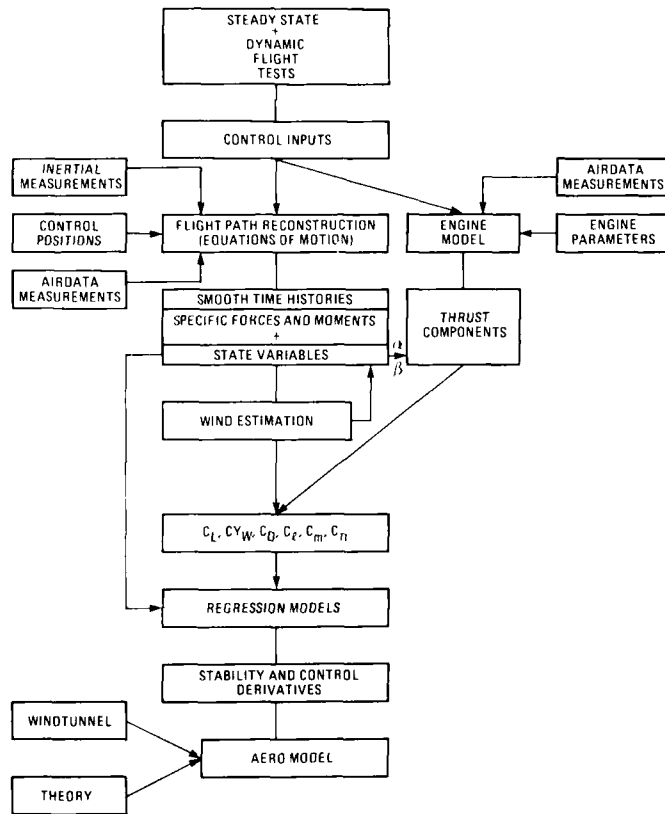

Fig. 5 Flight test data processing

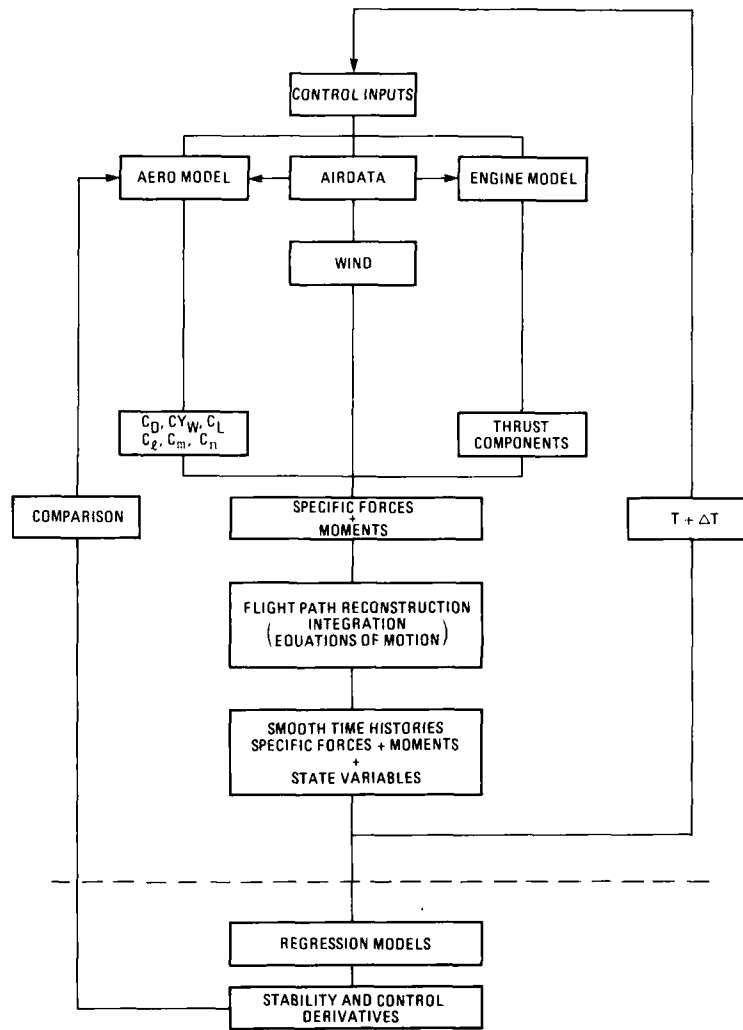

Fig. 6 Schematic view of simulation process

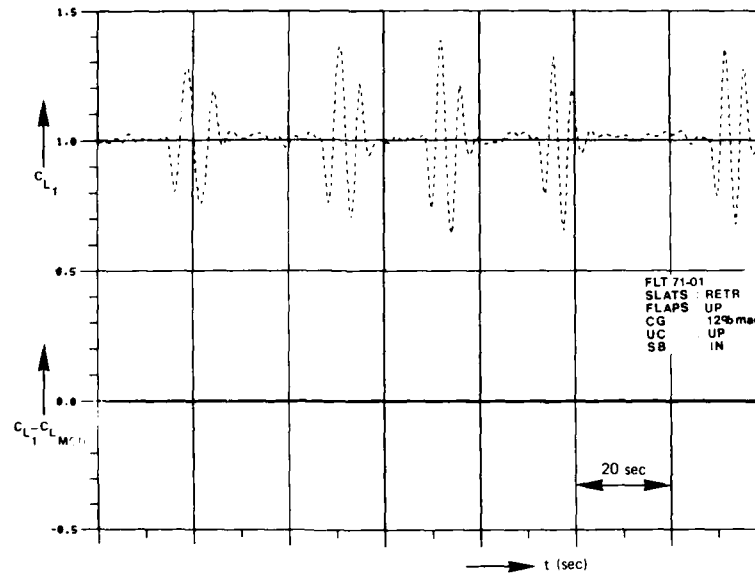

Fig. 7a Time history of C_{L1} and $C_{L1} - C_{L1_{model}}$ as obtained from simulator test data

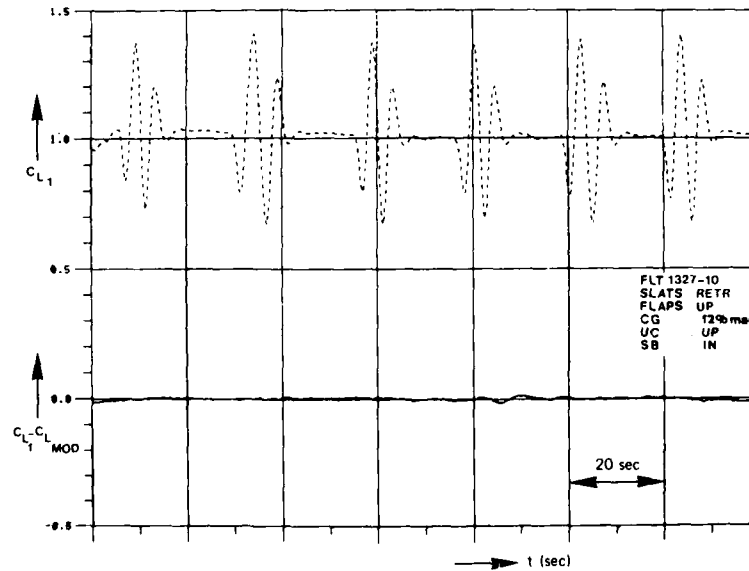

Fig. 7b Time history of C_{L1} and $C_{L1} - C_{L1_{model}}$ as obtained from flight test data

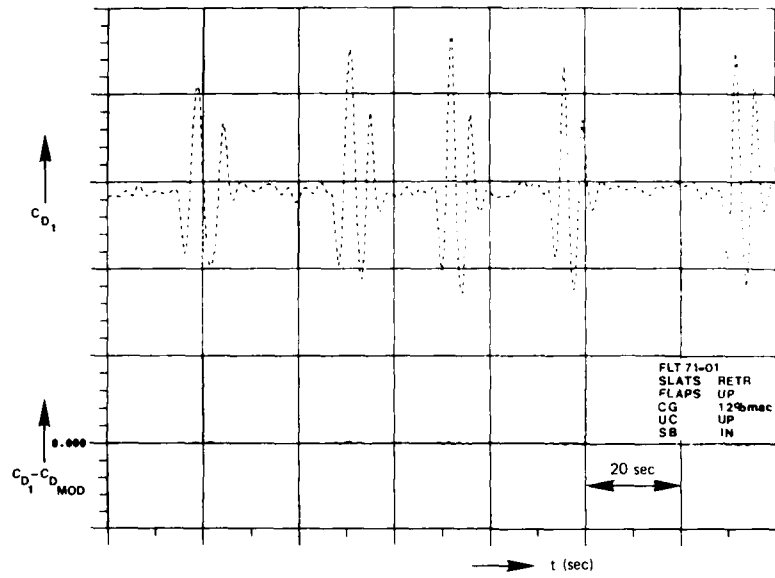

Fig. 8a Time history of C_{D1} and $C_{D1} - C_{D1 model}$ as obtained from simulator test data

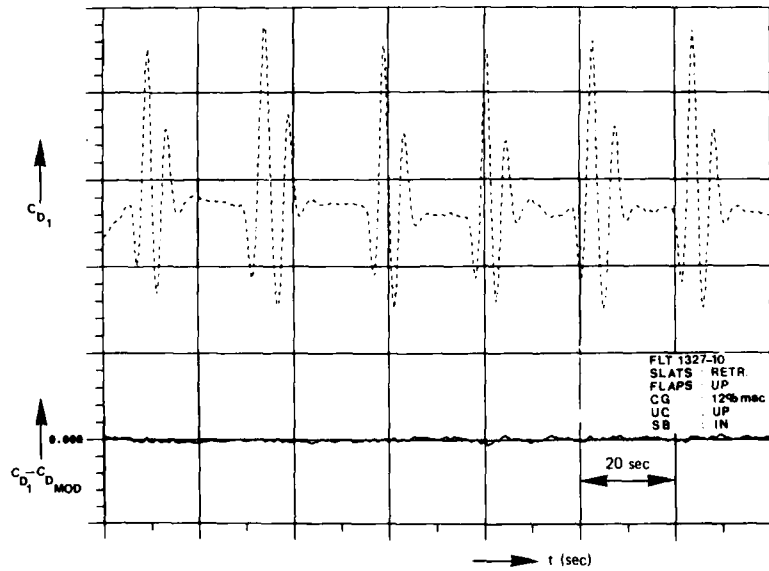

Fig. 8b Time history of C_{D1} and $C_{D1} - C_{D1 model}$ as obtained from flight test data

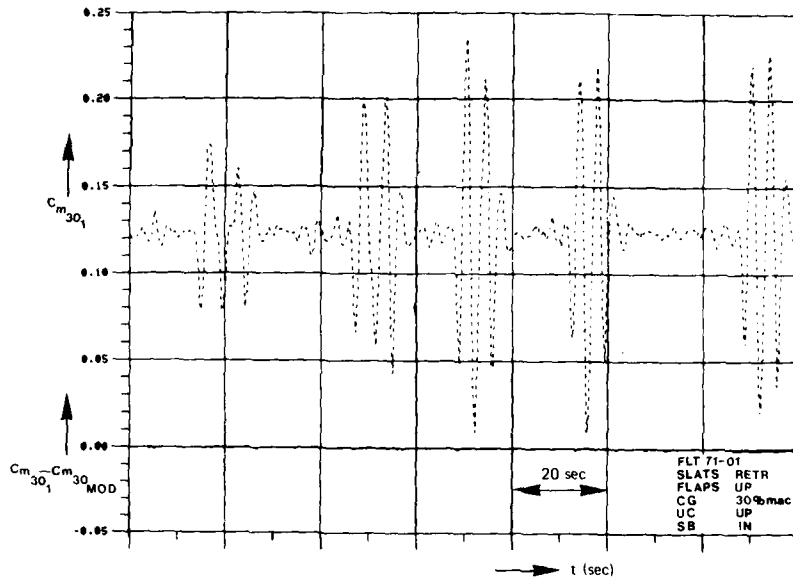

Fig. 9a Time history of $C_{m_{30_1}}$ and $C_{m_{30_1}} - C_{m_{30_1}} \text{ model}$ as obtained from simulator test data

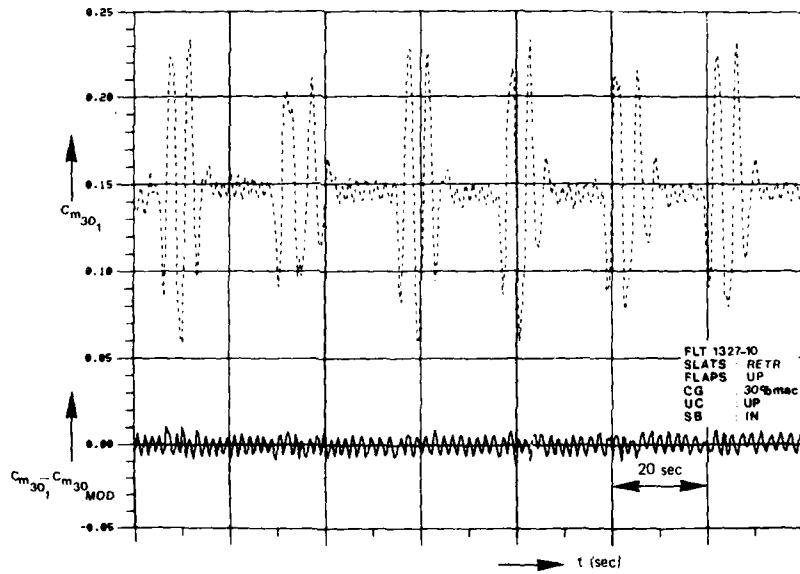

Fig. 9b Time history of $C_{m_{30_1}}$ and $C_{m_{30_1}} - C_{m_{30_1}} \text{ model}$ as obtained from flight test data

APPENDIX A
Transformation matrices

In this appendix the required transformation matrices are given used in the analysis of the data. Only the angles over which must be rotated are presented, because the complete matrix easily can be found by multiplication of the individual angle transformation matrices. The following matrices can be distinguished:

$L_{BV} = [\varphi] [\theta] [\psi]$	transformation from body axes to the vehicle carried vertical frame
$L_{FB_A} = [-\beta] [\alpha]$	transformation from the flight path axes system w.r.t. the air to the body axes system
$L_{FB_G} = [-\beta]_G [\alpha]_G$	transformation from the flight path axes system w.r.t. the ground to the body axes system
$L_{FV_A} = L_{FB_A} \cdot L_{BV} = [\nu] [\gamma] [\chi]$ system	transformation from the flight path axes system w.r.t. the air to the vehicle carried vertical axes
$L_{FV_G} = L_{FB_G} \cdot L_{BV} = [\nu] [\gamma] [\chi]$ G G G	transformation from the flight path axes system w.r.t. the ground to the vehicle carried vertical axes system
$L_{TB} = [a_p] [i_p]$	transformation from the thrust axes system to the body axes system

All transformation matrices are orthogonal, which means, that the transpose of the matrix is equal to the inverse:

$$[]^{-1} = []^T$$

Furthermore it applies:

$$[] []^T = [I]$$

in which [I] represents the unity matrix.

UNUSUAL AIRBORNE SIMULATOR APPLICATIONS

by
Philip A. Reynolds
TIFS/T-33 Program Manager
Arvin/Calspan Advanced Technology Center
P.O. Box 400
Buffalo, New York 14221

SUMMARY

Airborne simulation was conceived as a general purpose flying qualities research technique. Many diverse uses, forecast for the Total In-Flight Simulator (TIFS) while it was being developed, have come to pass, but diversity of application has exceeded even the most imaginative predictions. This paper describes some of the most unusual TIFS projects since it became active in 1971. The objective is to help define and illustrate the role of airborne simulation in aerospace research and development as it interfaces with analysis, ground simulation, and flight test.

INTRODUCTION

Airborne simulation was conceived as a general flying qualities test technique. The concept was broadened to include cockpit replication, allowing studies of cockpit human factors. Also, the development of full six degrees-of-freedom control, including force as well as moment controllers, allowed the flying qualities aspects of flight path control to be more systematically addressed.

When the U.S. Air Force Total In-Flight Simulator (TIFS) was first formally proposed in 1966, the contemplated uses covered four general areas:

- 1) Determination of general flying qualities requirements
- 2) Assistance in the development and acceptance of new airplanes
- 3) Investigation of flight control problems
- 4) Pilot training

There seemed to be no limit to the new simulator's applications. Once one had a "total" reproduction of the pilot's surroundings, many things could be considered that were previously possible only in the real airplane. Beyond that, it permitted testing emergency conditions that would be unsafe in the real airplane. It was also suggested that TIFS be used to investigate accidents involving loss of control. Some twenty eight different uses under the four headings above were mentioned in the 1966 proposal, extending from SST visibility tests to development of parts of the flight manual for a new airplane.

In the intervening years, many of these applications have come to pass. These include:

- Development of stability and control specifications
- Basic decisions regarding flight control systems and stability augmentation
- Detailed flight control system design
- Evaluation of emergency conditions
- Cockpit research involving arrangement, in-flight vision, pilot's instruments and general display development
- Final approach and landing characteristics
- Evaluation of a modification to a new airplane in flight test
- Simulation of flight in turbulent air
- Establishment of certification requirements by the "special conditions" concept
- Pilot training for first prototype flight

The common element throughout these studies has been, as it was first envisioned, a subject pilot in the TIFS evaluation cockpit performing prescribed flying tasks. However, there have been other uses.

During advisory meetings held early in the TIFS development, one airplane manufacturer suggested using the separate cockpit for studying rain removal from the windshield of his new airplane. This suggestion seemed almost facetious at the time but, in retrospect, it foreshadowed an aspect of airborne simulation application which has since been a dominant part of several TIFS programs - namely, that the capabilities that provide for reproduction of pilot/airplane closed-loop control characteristics also provide for other, sometimes quite different types of tests. These are the programs that are addressed in this paper.

Our objective in reviewing these TIFS programs is, in the words of our meeting theme, to "place the roles of ground-based simulators and in-flight simulators into context with one another and within the aerospace scene". We might add flight test to our view of aerospace since it is the next-door neighbor on the other side of in-flight simulation. When the TIFS was conceived, it was thought that flight testing would become so expensive - with the advent of wide-body transports, AMSA (the early B-1 program) and the SST - that some airplane development during flight test would be done in in-flight simulators. This has happened to some extent, with the space shuttle being the prime example, but not as much as it should.

This paper describes five programs accomplished between 1974 and 1983. The description concentrates on the origins of the program, experimental planning, preparation, flight tests, and general results. Since all these efforts were part of larger government programs which continued on into data analysis and study performed by other contractors and the government itself, overall conclusions are not covered here. It would be more appropriate for the sponsoring agency in each case to address the issue of airborne simulation value to the program in the larger context. What is attempted here, after the program descriptions, is a discussion of the role of airborne simulation from the Calspan vantage point with some sponsor perspective where it is available.

NC-131H (TIFS) DESCRIPTION

The in-flight simulator known as TIFS (Figure 1) is a modified C-131H twin-turboprop transport owned and administered by the U.S. Air Force Wright Aeronautical Laboratories. The overall responsibility for facility use resides in the Control Synthesis Branch, Flight Control Division, Flight Dynamics Laboratory. Calspan Corporation, which originally developed TIFS, operates and maintains the facility under contract.

Basic features include a separate side-by-side test cockpit with large vision angles mounted forward and below the standard cockpit. From this cockpit the simulator is controlled through fly-by-wire inputs to a hybrid computer system consisting of a mostly-digital real-time numerical representation of the dynamics to be tested and a mostly-analog motion reproduction system. The test cockpit is completely flexible in terms of controllers, displays, vision angles and control feel. The fly-by-wire system acts in parallel with the basic C-131 mechanical system. The safety pilot can instantly interrupt the simulation by electromechanically disabling the system actuators. System design and safety pilot experience allows routine operation to actual touchdown. The C-131 is able to reproduce, using explicit model following techniques, all six motion degrees of freedom by virtue of fully moveable vertical surfaces on the wings and inboard flaperons used primarily as direct lift controllers. Engine thrust is used to control longitudinal force.

When the experiment does not require the forward crew station, it can be replaced with a light nose fairing to allow more fuel for an extended test time or more equipment in the cabin area.

Recently, a second crew station has been provided for easy installation in forward cabin area. By replacing the evaluation cockpit with a nose section installation of several avionics systems including advanced radar, FLIR, TV and inertial navigation, TIFS becomes an economical avionics systems test training aircraft (ASTTA) for the military test pilot schools. Other uses for this configuration are mentioned later in the paper.

RIDE QUALITIES

Summary

As part of the NASA Langley Research Center program to develop the technology of ride quality, a TIFS flight test program was conducted in 1974. The objective was to obtain subjective reactions of a significant number of test passengers to a variety of controlled and repeatable motion sequences. The in-flight computer was programmed to precisely control the simulator's motions as specified by motion command signals pre-recorded on magnetic tape. A portion of the cabin was refurbished to provide a commercial airline environment for ten passengers. Reactions of subjects to a wide range of motions including single and multiple degree-of-freedom oscillations, both random and sinusoidal, and terminal area maneuvers were recorded.

Background

In the early 70's, ride quality was clearly shown to be a key factor in the passenger acceptance of any new air transportation system. Large-scale surveys of air travelers conducted at that time by the University of Virginia showed that ride quality ranked equal in importance to trip cost in determining a passenger's overall trip satisfaction. NASA was developing STOL transport concepts to cope with airport congestion and noise. However, it was evident that this approach would not be viable if passengers objected to the ride qualities. Cruise altitudes below 12,000 feet and curving, decelerating steep approaches were considered. Would a wide range of the traveling public accept such an operation? In 1971 NASA began a coordinated ride-quality research program. Initial experiments were conducted by voluntary questionnaire on scheduled commercial airline flights. These were followed by more detailed investigations using ground-based motion simulators.

Both of these approaches had significant limitations. In the commercial flight experiments, a particular motion environment was evaluated only once by a few subjects and could not be deliberately repeated with others. Also, the range of motion combinations was limited by the natural dynamics of the particular airplane used. Ground simulation was relatively inexpensive and was controlled and repeatable. However, the motion limits meant an inability to test low frequency oscillations and sustained maneuvers. In addition, it had not been established that passenger response to motion was independent of psychological factors such as fear of heights and thus would be the same during simulated flight as in real flight. Another drawback was the lack of ground simulators constructed to seat substantial numbers of passengers in an airline environment. Langley did build and run experiments in an airline cabin replica that could be vibrated several inches. It seated four and had no outside visual effects.

Planning

The test vehicle was required to execute random and sinusoidal oscillations in the frequency range .1 to 2.0 Hz and to move through three basic maneuvers - steady turn, constant climb or descent, and constant acceleration or deceleration along the flight path. Combinations of these motions were also required.

Modifications to the TIFS were required to seat as many passengers as possible in an airline environment and fly at least forty minutes under tape control. Administrative arrangements had to be made to allow the general public to fly in an experimental airplane. Continuous recording of the pertinent motion parameters throughout the test period was also required.

Preparation

Six double seats were installed in the forward cabin to allow ten passengers, a test director, and an assistant to be seated in an airline environment. The area was carpeted and curtained off from the remainder of the cabin area (Figure 2). Mahogany paneling with sound deadening liner was placed around the hydraulic console and was used to finish other parts of the area. Each passenger seat was provided with the standard amenities such as reading light, conditioned air, etc. A marine-type toilet was installed in a restroom adjacent to the area. A television camera was mounted in the cockpit to view the co-pilot's head motions. Another was mounted unobtrusively to view the activity of a few of the passengers. The images were recorded and also viewed on a split screen monitor. A third NASA observer was positioned in the test engineer area to monitor system problems, if any. The Calspan crew consisted of two pilots and two test engineers, making a total of seventeen people on board. To accommodate the extra weight, the evaluation cockpit, which was not needed for this program, was removed and replaced by the nose fairing.

The normal model following system was not used in this program because only three channels of motion - heave, sway and roll - were originally required. As the preparation evolved, all six degrees of freedom were controlled and, therefore, the standard model following system could have been used. The original control system tended to drift at low frequency when pilots were not in the loop. This was later eliminated by redesign. The airplane could perform the maneuvers and oscillations on the tape for forty minutes without pilot intervention. A two-axis side stick was provided to the co-pilot for checkout phase and for occasional slight modification of the airplane path during test for air traffic control or cloud avoidance. The maneuver tapes were prepared by hand flying the specified sequence with the tape machine recording the required motion variables. Sinusoidal and random tapes were provided by NASA. Typical sequences are shown in Tables 1 and 2. Each motion segment lasted 30 to 90 seconds and was preceded and followed by a period of no motion.

Table 1
RANDOM MOTION TAPE UVA-11

Segment	r deg/sec RMS	Segment	p deg/sec RMS
1	.2	11	1.2
2	.6	12	2.0
3	1.0	13	.4
4	.4	14	1.6
5	.8	15	.8
6	.4	16	2.0
7	1.0	17	1.2
8	.2	18	1.6
9	.8	19	.8
10	.6	20	.4

Segments 1-10: $q = p = 0$

Segments 11-20: $q = r = 0$

All Segments: $n_z = .040g$, RMS, $n_y = .028g$, RMS

Table 2
MANEUVER MOTION TAPE MAN-2

Segment	Maneuver No.	Description
1	43	Turn Entry
2	2	Level Flight
3	14	Turn
4	31	Deceleration
5	25	S-turn
6	46	Turning Deceleration
7	21	Turn
8	34	Deceleration
9	44	Turn Entry
10	10	Descent
11	19	Turn
12	33	Deceleration
13	30	S-turn
14	8	Descent
15	22	Turn
16	35	Deceleration
17	43	Turn Entry
18	45	Turning Deceleration
19	5	Descent
20	20	Turn
21	37	Deceleration
22	28	S-turn
23	4	Descent
24	13	Turn

The unusual situation of having the simulator safety personnel exposed to the same motions as the test subjects gave rise to some ride comfort motion limits of another sort. When preparing the sinusoidal tape segments, the amplitude limit was dictated by the pilots in many instances. Table 3 lists motion extremes for single channel operation used in TIFS for this experiment. The pilots' limits were dictated by concern for takeover transients, hardware cycling or an intuitive motion of what the subjects would tolerate. The motions are single channel and do not reflect what normal simulation limits would be when reproducing airplane-like motion. For example, the motion limits in pitch rate at .05 and .1 Hz resulted from the direct lift flap (DLF) nearing its position limits while cancelling the lift due to ± 1.8 to 2.2 degrees of angle of attack change. The motion was single channel - no normal acceleration change was permitted.

Table 3
EXTREMES USED IN SINGLE CHANNEL SINUSOIDAL MOTION
(208 KIAS, PEAK VALUES)

f Hz.	q deg/sec	n_z g's	r deg/sec	p deg/sec	n_y g's
.05	.7 DLF Position	.20 Safety Trip	1.0 Sideslip Angle	6.3 Bank Angle	.14 Pilot
.1	1.1 DLF Position	.25 Pilot	2.0 "	- - - -	.15 Pilot
.5	2.8 Pilot	.35 Pilot	2.5 Pilot	11.0 Pilot	.11 Pilot
1.0	1.7 Pilot	.30 Pilot	.8 Pilot	5.0 Pilot	.09 Pilot
2.0	.5 Pilot	.13 Hyd. Noise	.2 Pilot	2.5 Pilot	.07 Pilot
3.0	- - - -	.10 Hyd. Noise	.15 Pilot	1.5 Pilot	.04 Pilot

It is interesting to note that the pilots would only tolerate 11 degrees per second roll rate when under system control at .5 Hz. However, the system is capable of 30 degrees per second, and the pilots have seen roll rate peak this high in some simulations. The motion at low frequency is an unusual rolling maneuver with n_z and $n_y = 0$ and no pitch or yaw rate. The maneuver amplitude was determined by the maximum desirable bank angle, which was about 20 degrees.

Note that the side acceleration extreme was set by pilot preference at all frequencies tested.

Flight Tests

Forty flights averaging 1.3 hours were flown during a three-week period. The number of test subjects numbered 115. Each flight consisted of a brief segment to fly from Langley Air Force Base to the test area, operation under tape control for 40 minutes, and return to base. Twenty-three forty-minute tapes were prepared - two maneuver tapes, five sinusoidal tapes, and sixteen random motion tapes. All but two were tested at least once, seven were tested twice and one was tested seven times. As the various test motions were experienced, the test director announced over the public address system the beginning and ending of each evaluation interval. At the end of each evaluation interval, each passenger recorded on a rating sheet his or her total comfort using a seven point rating scale ranging from "Very Comfortable" to "Very Uncomfortable". Written comments were also solicited. It is worthy of note that only one flight had to be aborted due to motion sickness - a tribute to the experiment designers.

General Conclusions

Quoting from Reference 1,

"A variable-stability research aircraft has been successfully modified and flown to provide prescribed, closely controlled and repeatable flight motions for ride-quality research. Several problems were initially experienced with the motion control system but solutions to these problems were effected. The aircraft modifications, while not necessarily ideal, did provide a useful range of motion capability, a realistic passenger environment, and a convincing demonstration of the validity of this flight technique for ride-quality research. A series of meaningful ride-quality flight experiments were carried out using the modified aircraft and the research findings promise significant advancement in ride-quality technology."

REMOTELY PILOTED VEHICLE

Summary

In 1974, Flight Dynamics Laboratory of AFWAL (U. S. Air Force Wright Aeronautical Laboratories) sponsored an in-flight simulation of remotely piloted vehicle (RPV) operations in the terminal area. The objectives, as part of a larger program defining overall requirements, were to develop, test, and demonstrate satisfactory performance of a remote-operator-supervised, automatic takeoff and landing system for the Compass Cope. The NC-131H (TIFS) was modified to be capable of remote operation including pattern operation, landing, rollout, and part of takeoff. During the spring and summer of 1975, over 200 automatic and semi-automatic landings were made at Wright-Patterson Air Force Base. Based on the resulting data, design guidelines for a RPV takeoff and landing system were prepared.²

Background

Reliable recovery of RPV's was a problem in 1974, and the landing of Compass Cope - an aircraft with light wing loading and large span - in all weather conditions posed additional challenges (Figure 3). The role of the remote operator (RO) in combination with the automatic system to maximize recovery reliability and minimize system complexity needed definition. Piloted ground simulations were used to develop an RO console and provide data on landing performance using mathematical models of atmospheric turbulence, guidance system noise, and automatic landing system closed-loop behavior. The flight phase following this system development phase would provide landing performance data in the presence of real turbulence, system noise, autoland behavior, and the added pressure on the RO of controlling a real airplane in flight. The intended role of the RO was that of a supervisor of the automatic landing and a manual backup controller in the event of autoland failures.

In-flight simulation was chosen for the flight phase as the most advantageous way to obtain good reproduction of Compass-Cope RPV dynamic behavior with a high level of safety and cost effectiveness. Alternatives were examined at the Flight Dynamics Laboratory and discarded for various reasons. An actual RPV was much more costly. The hardware would have been required to meet much more stringent reliability, volume, weight, and power constraints. The backup to the RO/autoland system combination would not have tolerated much off-nominal behavior or some of the crosswind and turbulence conditions intended for the tests. The RPV would not have behaved dynamically like the Compass-Cope. An RPV modified to accommodate a pilot on board and the autoland equipment was also discarded as too costly, and it also would lack dynamic reproduction of the Cope.

Planning

The test program was designed to collect quantitative and qualitative performance data on the autoland system and its major elements: automatic flight control system, landing guidance system, and the RO's control station. Test flights would be performed in simulated adverse weather - winds, turbulence, limited visibility (TV forward view) - for a realistic assessment of system performance. Also, autoland failures would be introduced which would require the RO to recognize malfunctions and to actively enter the control loop to land manually.

The data collected would be analyzed to assess: localizer capture and tracking accuracy, glide slope capture and tracking accuracy, RPV runway alignment maneuver accuracy, flare control, touchdown dispersion, ground rollout control accuracy, takeoff system performance, speed control system performance, angle of attack control system performance, and control surface activity compatibility with selected landing guidance system.

To evaluate the adequacy of the RO and autoland integration, the data would be analyzed to determine:

- a. the RO's ability to establish initial conditions prior to autoland engagement
- b. the RO's ability to monitor autoland performance, detect failures, and to remotely control the RPV
- c. the RO's ability to cope with single and multiple failures
- d. adequacy of selected control modes for the precise attitude and path control required by the takeoff and landing operations
- e. usability of an on-board television system as an aid in RPV launch and recovery.

The test plan also called for detailed performance assessment of two portable microwave landing systems used for the precise landing guidance.

Preparation

As in the Ride Quality program, the evaluation cockpit was not needed. The evaluation pilot was on the ground. However, this time the nose fairing held an instrumentation planform on which was mounted the microwave landing system (MLS) antenna and receiving equipment, a forward-looking TV camera, MLS data recording electronics, and time code generator.

Five other systems were assembled and installed:

- Telemeter downlink
- Telemeter uplink
- Color television broadcast
- Electrohydraulic nosewheel steering
- Electrical braking.

The downlink handled 25 analog and 20 discrete signals to drive the RO station. The uplink contained four controller signals - roll, pitch, yaw, and speed - and 18 discrete commands. Color television was displayed to the RO as a redundant means of locating the runway and positioning the aircraft on close final. Steering and braking systems controlled by electrical signals allowed landing rollout and a portion of the takeoff control functions to be controlled from the ground.

The simulation was constructed much like a conventional six-DOF TIFS model-following configuration with telemetry links to the RO replacing the usual wires (Figure 4). When the main gear spin-up switches were closed, the model feedback was switched to TIFS sensor outputs. The system became an MLS centerline steering control with the NC-131H dynamics. For takeoff, the RO and/or automatic systems had control except for the throttles which were handled by the TIFS safety pilots to avoid extra complication. A specialized discrete logic computer was added to provide the logical operations required of the RPV flight control and autoland system. (Presently, such functions can be easily handled by the TIFS digital computers which, on the impetus of this program, were installed two years after this program was completed.) Protection against transients caused by telemetry dropouts was attempted in the TIFS downstream electronics, but it was not successful. Therefore, telemetry dropouts would cause the TIFS safety circuits to disengage the simulation, instantly returning control to the TIFS safety pilots. This did not prove to be a problem since dropouts seldom occurred after final approach capture.

Airplane position as determined by the MLS was independently measured by a laser tracking system. Ground effects in the model and flare dynamics were controlled by the TIFS radar altimeter.

The nominal weight and speed for the Cope RPV in landing approach was 5700 pounds at 100 knots. This speed was too low for the TIFS, with a minimum safe approach speed for simulations determined to be 120 knots. Therefore, it was decided to fly the approaches at 120 knots and use an RPV weight of 8200 lbs. to yield the same n_z/α , C_L , and α as the nominal approach condition.

The light weight of the RPV made the dynamics a challenge for the TIFS to reproduce. However, good model-following performance was obtained for still air and light-to-moderate artificial turbulence disturbing the RPV model.

Flight Tests

The basic flight profile flown in the RPV program is shown in Figure 5. The TIFS command pilots normally flew the portion from takeoff to the localizer intercept position. Each run would begin in an automatic land mode with selected available remote control modes. Then, either the aircraft would fly an automatic approach to touchdown or in the event of an experimenter-induced control channel failure, the RO would actively participate to obtain a touchdown. One, two, or three control channel failures were introduced at selected portions of the approach. It was possible to make about ten approaches under various levels of RO control in a flight of 2.5 hours.

Initial checkout flights were flown at Buffalo using the evaluation cockpit and standard ILS guidance. Some telemetry checks were made. The MLS nose was installed and the TIFS was flown to Wright-Patterson AFB where the Air Force directed further development flights integrating the ground station, MLS, and laser tracker. The program emphasis then changed to system modification. The Air Force project engineer had the opportunity to observe first-hand how his control system was behaving and make changes - sometimes during the course of a flight. With the system optimized, data runs were made. In all, about 150 hours were flown, of which the final data runs consumed about 63. The number of complete data runs flown was 175.

General Conclusions

Several improvements were made to the basic manual control system and the autoland system. The basic system had an adverse yaw problem which did not make an impression on the experimenters until it was seen in flight. Glideslope and localizer signal filters in the automatic landing system had to be optimized, trading off control surface behavior with tracking performance. Localizer capture and tracking gains were also changed after flight test. Numerous improvements were made to the manual control system. These included gains in the heading hold and flight path angle hold modes, and filters and faders to smooth transients in the manual takeover.

The data included performance of the autoland system in terms of approach tracking errors, control surface activity, and touchdown parameters such as position, sink rate, heading, bank angle, etc. It also included handling qualities data in the various autoland failure modes and MLS signal properties for the Wright-Patterson site.

WINDSHIELD DISTORTION

Summary

Under sponsorship of the Air Force Aeromedical Research Laboratory, a program to gather data on windshield vision distortion was carried out in late 1976. The objective was to provide substantiating information for windshield optical specifications in the forward foveal vision area used during landing from breakout to touchdown. The flight tests involved night landings from the TIFS evaluation cockpit using fly-by-wire C-131 dynamics. Various test panels were placed inside the cockpit between the eye point and the TIFS actual windscreen, causing distortion of the light patterns and variations in landing performance. MLS equipment was used to provide high-accuracy guidance and trajectory definition.³

Background

Experience in the design and use of windscreens for high-speed aircraft identified a need for practical minimal optical specifications which would assure that windshield optical characteristics do not interfere with acceptable and safe visual performance by pilots. Windshield developments for the F-111 and B-1 programs demonstrated that previously accepted optical standards were difficult to meet because of other design demands such as bird strike proofing, high aerodynamic forces, and radar reflective coatings. Some windshields which did meet standards for distortion on the F-111 were found unacceptable for operational use.

Planning

Flight data was needed under highly controlled conditions which, together with ground simulator and laboratory data, would form the basis of new windshield optical specifications for VFR terminal area operations. A flight experiment was designed to force the pilot to use outside visual cues to adjust the airplane's flight path, to investigate a critical flight path control problem requiring good visual judgments to produce good performance data, and to produce enough data within the fiscal constraints to average out variations due to lapse in pilot performance, changing wind and turbulence conditions, changing lighting conditions, and other effects.

Preparation

TIFS was used because its evaluation cockpit was spacious enough to accommodate a flat windshield test panel of substantial size. By using TIFS rather than a conventional airplane, inexpensive panels which were non-load-carrying and easily interchangeable could be used. The good optical properties and large viewing angles of the TIFS evaluation cockpit canopy were also necessary.

Some of the same MLS equipment used in the RPV program was installed in the evaluation cockpit forward of the instrument panel. The cockpit controller electrical position signals were used to directly drive the TIFS actuators, producing a fly-by-wire version of the NC-131H. Cockpit force feel gradients were optimized. The TIFS needed no modification to provide 58 channels of motion control and guidance data since the airplane is fully instrumented for simulation work.

Flight Tests

A brief program of 19 hours was flown during which more than 100 approaches were flown by four Air Force C-131B pilots. Four conditions were tested with each pilot - no panel and three panels with differing distortion.

The data flights and the practice flights were all flown at Niagara Falls between the hours of 7:30 pm and 4:00 am. The visibility criterion was such that the lights of the city of Niagara Falls were visible in the background throughout the visual portion of the approach. The farmland in the foreground was sparsely lighted. The TIFS right landing light was used but the left light was not, due to side lighting effects on the test panel.

The approach was started by engaging the fly-by-wire system on the outbound leg and giving heading vectors to the evaluation pilot intercepting the MLS localizer either at the outer marker or just inside it. The Air Force test director in the right seat of the evaluation cockpit placed a cardboard panel in front of the evaluation pilot to block his forward vision.

The normal ILS 2.5° glide slope was used down to a radar altitude of 1000 feet. At this point, the signal was smoothly transferred to a computed quantity based on distance from the MLS and radar altitude for increased accuracy. The computed glide slope was also 2.5° with the same point of origin.

The evaluation pilot flew with references to the flight director needles, the ADI, the HSI, the airspeed indicator, and the DME readout. Altitude and rate of descent indications were taped over to prevent cross-checking after going visual.

At 2.0 nautical miles from runway threshold, the flight director needles were driven out of sight and the cardboard panel was removed. At this point, the approach was continued visually. Localizer bias was used to position the airplane either to the right or to the left of centerline approximately 400 feet at the two-mile point. From this point, the task was to obtain a "touchdown" on centerline and as close as possible to the second string of blue taxi lights on the right side of Runway 28R. This point was also marked by the beginning of the runway lights on the right side. To more closely match the C-131 eye height and to allow data runs with maximum fuel, the landing maneuver did not conclude with an actual touchdown but with an audio signal at a TIFS wheel height of five feet as measured by radar altitude. The go-around was made by the TIFS safety pilots.

On all approaches, the TIFS crosswind cancelling circuit, which removes the requirement to fly with a crab angle based on the reported surface winds at the start of the approach, was used. If natural turbulence was not present, a taped set of random signals was added to the actuator commands to produce light motion disturbance, forcing the evaluation pilot to make continued corrections.

General Conclusions

The needed flight test data was obtained cost effectively using the cockpit flexibility, experimental control, and real-world visibility of the in-flight simulator.

MOTION RESEARCH

Summary

Airborne simulators, with their full sustained motion cue capability, are obvious devices to apply to the pressing motion questions continually arising in simulation. In the late seventies, the Air Force Human Resources Laboratory initiated this research approach at the basic level by sponsoring an experiment to gather psychophysical motion perception data and study related aspects of motion cuing. Using a series of maneuvers without outside visual cues or any instrumentation, a subject was asked to give measurements of motion perception. These data were later analyzed in an attempt to more closely define the parameters in various human sensor mathematical models.⁴

Background

By late 1977, a multi-sensory motion perception model had been developed using an optimal estimation approach to the integration of the known human multiple sensors.³ The model was capable of exhibiting correct qualitative human response characteristics. It was proposed that the model be used to help develop the data base for determining motion and force simulation requirements for aircrew training. Since airplane motion duplication is impossible on the ground, the intention has always been to attempt duplication of the perception of motion through the proper integration of motion cuing devices such as g-seat, g-suits, limited whole body motion, helmet loaders, etc. The model would be able to indicate where perception was incorrect and what might be done to improve matters. However, more extensive data was needed to, in the words of the Air Force requirement document, "define the actual g-environment experienced during particular maneuvers". It was suggested that an aircraft be instrumented and flight tests be made.

Planning

Reference 5 described several data needs existing in late 1978. These had great influence on the planning for the TIFS experiment. Coordinated turns, sustained normal accelerations, and sustained longitudinal accelerations were three maneuvers mentioned which could not be adequately tested for perceptions in existing motion-based ground simulators. Seat pressure data during sustained maneuvering was needed for input to the tactile portion of the model. Pressures needed to be measured over the entire back and buttock area. Also, very little data was available to support the head-neck proprioception model described in Reference 5. Measurement of dynamic head displacement and of the electro-physiological head-neck response during abrupt and sustained motion was needed. Reference 5 concludes by suggesting five experiments: flights in TIFS, a vibration masking effect experiment, a minimum platform displacement determination for immediate and sustainedvection (visually induced motion sensations) with a wide visual field, a g-cuing seat experiment, and a tactile vibration threshold experiment. Plans for the first two were going forward and the third was in progress in 1978.

Preparation

The evaluation cockpit was divided by a curtain. The left side was unchanged. It was still a pilot's station with the normal arrangement and the normal vision forward and to the left. The right side was fully enclosed from the outside world and devoid of flight information.

The left seat was occupied by an experienced pilot who, at times, flew various maneuvers but mostly rode as a passenger like the right seat occupant, who was not usually an experienced pilot, while the maneuvers were flown from the command cockpit or input by a test engineer at the computer.

The right-seat subject was given a pointer for tracking the sensed vertical in pitch and roll. The same device was used to indicate the magnitude of roll rate or longitudinal acceleration. In the latter mode, the pointer was just a means of changing the needle deflection on a large meter in front of the subject, providing a means of quantitatively indicating to the experimenter what was being perceived.

Pressure-sensing pads were installed on both seats and backs. Head motions of both persons were recorded by separate video cameras. Electrodes were installed on the neck of each subject to sense electromyographic activity with the intent to correlate neck muscle, control with maneuver input, and head motion.

The computer control system was configured once again to perform arbitrary computer-commanded maneuvers. It was modified somewhat over the system used in the Ride Quality program. Control capability was provided from the evaluation cockpit, the command cockpit side controller and the test engineer's station. No airplane model was mechanized.

Flight Tests

Two checkout flights and seven data flights were conducted in the late spring of 1979. Seven right-seat subjects (all Calspan employees) with differing flight experience were flown. Some had no experience; one was a flight instructor; one was a test pilot. One female and six males were used. The left-seat subject was a Calspan test pilot.

Each flight plan contained 49 maneuvers broken up into three groups: Down Tracking, Roll Rate Tracking, and Acceleration Tracking. For Down Tracking, the subject's task was to continuously aim the instrumented pointer in the "down" direction during each run. The meter was masked from view of the right seat subject during this flight phase. For the Roll Rate Tracking phase, the meter was uncovered and was positioned by the subject's pointer to indicate magnitude of roll rate. The subject was calibrated to a reference roll rate or modulus of 5 degrees per second given as a constant rate from zero to ten degrees of bank and was told to indicate this roll rate as 5 meter divisions. The subject signified test run roll rates by deflecting the pointer more or less than the deflection for the modulus. The Acceleration Tracking phase was similarly performed. The modulus or reference was a .1 g longitudinal deceleration which the subject was told to indicate as 5 meter divisions.

The groups of maneuvers are indicated in Figure 6. They were performed in level flight except for the "roller coaster" sequence. The uncoordinated maneuvers were seat tilting time histories which could be performed in the TIFS using its direct force controllers in combination with moment controllers.

The majority of runs were scheduled to be controlled from the test engineer location. During flight checkout, it was found to be most expedient with little loss of repeatability to have the command pilots fly the forward acceleration runs. The left seat subject pilot flew the maneuvers specified by the flight plan but was mostly a passenger like the right seat subject.

General Conclusions

This experiment was performed cost effectively and generated a wealth of data. A portion of the data has been analyzed and reported in Reference 6. The spacial orientation data confirmed that subjects have a fairly accurate perception of angle and rate during uncoordinated maneuvers, but coordinated turns feel like a roll in and then a roll out to a bank angle in the opposite direction. Roll rate perception was fairly accurate and was not the derivative of roll angle perception. The mathematical model was in qualitative agreement but had put too much weight on roll rate from the semicircular canals relative to roll angle cues from the otolith organs. The predicted pitch-up illusion in a level turn could not be confirmed or denied by the data analysis due to scatter.

The head/neck biodynamics results indicated that the subjects without visual cuing did indeed behave differently from the the subject with outside vision. They leaned into the turn and they usually contracted only the neck muscles on one side, whereas the "pilot" subject frequently contracted both sides, presumably stiffening the neck. The muscle torque was predicted fairly well in the steady state response to a .2 g lateral input but not in the transient where a large initial overshoot was observed.

The seat pressure results at low frequency showed that a simple mass model is adequate.

COMMAND FLIGHT PATH DISPLAY (CFPD)

Summary

This program, sponsored by the U. S. Naval Air Development Center, was undertaken to establish the CFPD concept validity in the in-flight environment. Successful development, evaluation, and demonstration flights were flown in the early spring of 1983. TIFS was chosen as the flight test vehicle because of the ease of cockpit modification and incorporation of a sizable head-up display, full complement of instrumentation, and the cabin volume and electrical power available. The experimental CFPD system weighed about 1100 lbs and used 6 KVA of 60 Hz power. The CFPD concept consists of a totally integrated pictorial presentation of the fundamental information necessary to effectively perform all of the normal basic flight operations with or without reference to the real world. Two displays were implemented: an earth plane contact analog with a superimposed flight path and lead airplane and a map-type horizontal situation display.

The specific program objectives were to demonstrate instrument flight without reference to conventional displays, to establish the level of instrument flying performance that could be achieved with minimal training on the displays, and to prove that the electronics system required to generate CFPD could be achieved through computer graphics picture processing techniques.

Background

The CFPD development started 39 years ago with a 1946 study by the Flight Section, Special Device Division, Navy office of Research and Invention in conjunction with the University of Illinois. In 1946 and for many years after, there was no known means for mechanizing the display concept. In 1952 the Office of Naval Research, and later the Army, established the Army-Navy Instrumentation Program (ANIP) to develop a new concept for aircraft instrumentation. Although each of the man-machine research areas received attention, the central computer processor driving displays was emphasized. The work resulted in many advances, but it was not until 1972-73 that computer graphics techniques made real-time, detailed computer-generated images possible. The Naval Air System Command through NADC sponsored a feasibility study at Northrop which produced a demonstration of ANIP-type pictorial displays in a ground-based flight simulator. The only remaining conceptual unknown was whether improved IFR flying performance could be demonstrated in actual flight.⁷

Planning

A separate planning phase under NADC sponsorship took place during the eight months preceding the start of TIFS involvement. This work, performed by the Resource Management Systems Division of Systems Associates, Inc., of California, defined a general block diagram, identified hardware and defined delivery schedules. The plan was to use commercial, laboratory-type hardware since airborne or military hardware was either not available or undeliverable at the time desired. Flight planning aimed at achieving the objectives mentioned above was performed early in the software development phase. A closed circuit was defined (Figure 7) which could be flown at the altitudes corresponding with a landing at the end at Niagara Falls Air Force Base or could be flown at considerably higher altitudes for initial flights, familiarization and demonstration. The starting point of the circuit could be set at an arbitrary longitude and latitude.

Preparation

The CFPD system required installation of computers, displays, an inertial platform, a TV system, and a 60 Hz power capability. The two pictorial displays are shown in Figures 8 and 9. The pathway perspective shows plates which passed under the pilot at a rate proportional to velocity. The pilot's task was simply to fly in loose formation with the airplane on the left hand side of the pathway. Velocity commands were given by causing the airplane in the picture to accelerate or decelerate. The horizontal situation display was a vertical view without perspective showing present position. The correct position was signified by the airplane being within the circle as shown.

The general block diagram is Figure 10. Basic to the system was the Evans and Sutherland PS-300 which could be programmed to present the desired pictures and update these pictures at an acceptable rate. This computer is a commercial graphics processor and had never been out of a fixed office or laboratory environment, much less flown. As part of this program, Calspan hardened the PS-300 and tested it successfully in the TIFS-measured vibration environment before installation. Having a flight-worthy graphics processor, the system reliability was satisfactory since the remaining equipment, although used mostly in laboratory environments, was fairly rugged.

The PS-300 provided stroke writing commands at four output ports. The Hughes AIDS head-up display was an alternate to the head-down Xytron CRT vertical situation display. The two were not in the airplane at the same time. A third output of the VSI pathway display was used for video recording. The picture was updated from information computed in the PDP 11/44 and its associated input/output chassis. TIFS sensor information, the inertial navigation system, and conventional ILS information was used to locate the pilot's eye relative to the pathway.

Being laboratory equipment, most of the CFPD equipment required 60 Hz power. The TIFS had an excess of 400 Hz power available and also ballast in the tail cone that could be replaced by 60 Hz converters. Two 3.5 KVA converters were added to the airplane simulation system as a permanent installation.

Flight Tests

Thirteen flights were flown in the early spring of 1983. The first three were used for checkout and the remainder for evaluation and demonstration to Navy pilots and officials. Four features of the TIFS simulation system were planned for use during checkout. The variable feel system was used to allow the pilot to select characteristics which were pleasant to fly on the display. The Convair dynamics were improved with increased Dutch roll damping and reduced yaw due to ailerons. This improved control of lateral position on the pathway but was used only during ground checkout. Apparently due to the difference in cues between ground and flight, the stability augmentation was not needed in flight. The crosswind simulation system was planned for cancelling the existing crosswind on an actual final approach but was not used since few actual approaches were investigated. Finally, the ground simulation capability was used for display detailed development and pilot familiarization prior to a demonstration flight.

An alternate conventional ADI and HSI presentation, also prepared in the computer software, was used to generate performance data and pilot commentary for comparison purposes.

General Conclusions

The CFPD pathway concept successfully passed its initial flight evaluation, demonstrating several advantages over conventional instrumentation. The program objective of flight without auxiliary information using computer graphics techniques with ground laboratory hardware was achieved. Time delay due to the data link between the host computer and the graphics processor, had no great effect on the pilot's ability to fly the pathway around the test circuit, and it can be reduced by using faster techniques now available. The presentation of velocity command was found in need of improvement.

DISCUSSION

Use of TIFS Features

We noted that in all these programs, the TIFS simulation equipment and features were used for other purposes. In the Ride Quality program, the motion system was used for repeatable sustained maneuvers and controlled vibratory motion. The coincidental availability of a large area of the cabin for passenger subjects was also a major factor in the experiment. The RPV program introduced an uplink telemetry capability and demonstrated that the motion system and the pilot's station could be remotely separated. That program also emphasized that ties between the model equations of motion and real-world guidance could be used to study real sensor effects on the model behavior. Attitude, velocity, and short period flight path control were, however, accomplished by mathematically closed loops in the model computer. The Windshield Distortion program demonstrated the importance of the separate evaluation pilot's station. In a conventional test bed aircraft, replacement half windshields and/or extensive cockpit modification would have been necessary to attempt such an experiment.

The Motion Research program demonstrated another use for the TIFS motion system. The fact that visual cues and motion cues could be picked apart and studied in detail is an important example of what could be done much more extensively using artificial visual cuing. The experiment performed simply compared full vision with no vision. The program also reminded us that non-airplane-like motion can be produced with an in-flight simulator. Finally, the CFPD program used fly-by-wire and simple simulation techniques to easily overcome obstacles that a test bed aircraft could not. The low Dutch roll damping of the NC-131H made the pathway unnecessarily more difficult to fly. The fact that the Convair could be made more pleasant to fly allowed the experimenters to remove airplane dynamics as a factor in the display evaluation - a factor which was undesired for this early flight test. The separate, flexible evaluation cockpit was also quite advantageous for the hardware available at the time.

Relationship to Ground Simulation and Flight Test

These programs were selected for this paper to provide illustrations of various ways in-flight simulation filled needs that ground simulators could not satisfy. They mostly illustrate the non-piloting role of full, sustained motion cuing but also include real sensor effects which are not well modeled at present and subtle visual effects such as night depth perception through distorted plexiglass. The ride quality example also shows that special problems such as testing large numbers of subjects at once can be handled.

In view of the uniqueness of some of these applications, we in the aerospace community should be alert to in-flight simulation capabilities complementary to ground simulation and to flight test in test bed aircraft. History has certainly shown that a wide variety of research and development beyond the important pilot closed-loop control work can be accomplished.

Future Developments

As far as TIFS is concerned, future developments will focus on computer upgrade, improved efficiency, and the ASTTA derivatives. The model computers will be replaced in the near future by a Rolm Model 32 32-bit airborne computer system which will add improved speed and programming efficiency. The ASTTA configuration clearly lends itself to modern cockpit integrated display and control research since more volume at the crew station and more weight-carrying capability will be available. The airborne radar, FLIR and other avionics can be used for more realistic mission simulation. This arrangement is also more suitable for simulation technology or cuing research, using artificial visual scenes.

REFERENCES

1. Schoonover, W.E., Jr. and Dittenhauser, J.N.: "Ride-Quality Testing Under Controlled Flight Conditions, AIAA Aircraft Systems and Technology Meeting, Preprint 75-987, August 1975.
2. Huber, R.R., and Reynolds, P.A.: "In-Flight Simulation - A Unique Approach to Flight Testing an All-Weather Landing System", AIAA Visual and Motion Simulation Conference, April 1976.
3. Reynolds, P.A.: "Calspan Data from the Windshield Distortion Flight Tests", Calspan Internal Memorandum, TIFS No. 807, October 1976.
4. Dittenhauser, J.N.: "Motion Perception and Related Measurements Obtained in Flight-Data Report", Calspan Report No. 6241-F-4, December 1979.
5. Borah, J., Young, L.R., and Curry, R.E.: "Sensory Mechanism Modeling", AFHRL-TR-78-83, February 1979.
6. Borah, J. and Young, L.R.: "Special Orientation and Motion Cue Environment Study in the Total In-Flight Simulator", AFHRL-TP-82-28, June 1983.
7. Systems Associates, Inc. of California: "Command Flight Path Display, Phases I and II", R83-49, September 1983.

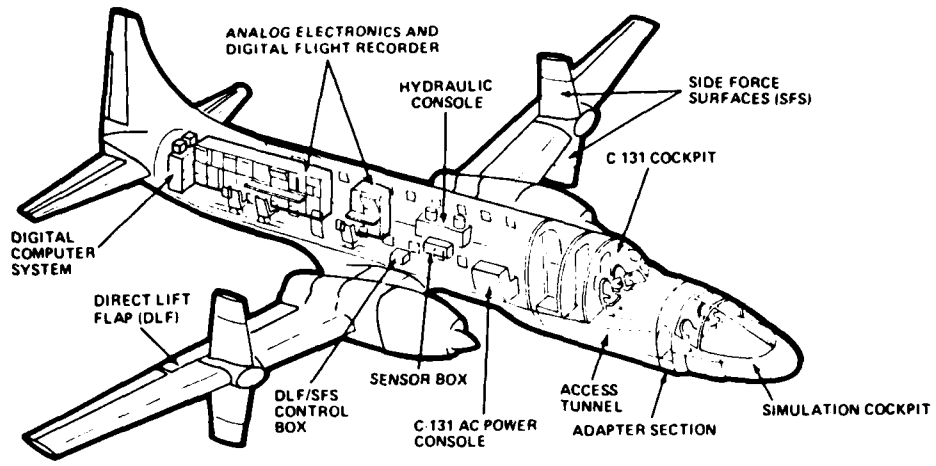

Fig. 1 TIFS General Arrangement



Fig. 2 TIFS Passenger Compartment for Ride Qualities Experiment



Fig. 3 Compass Cape RPV

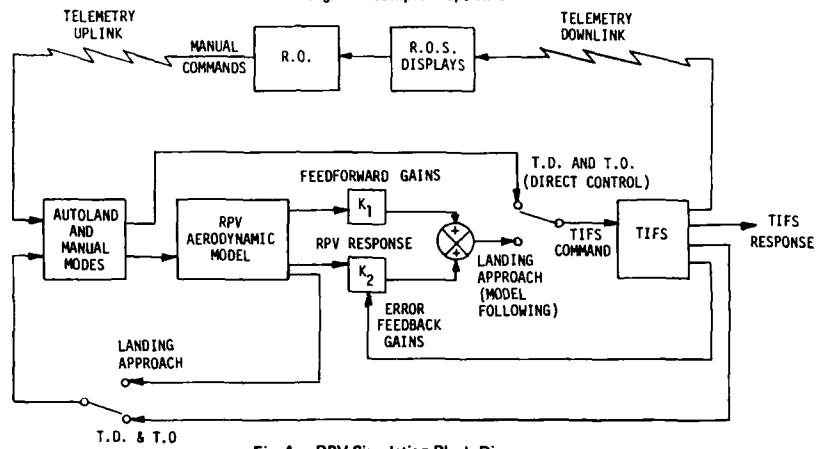

Fig. 4 RPV Simulation Block Diagram

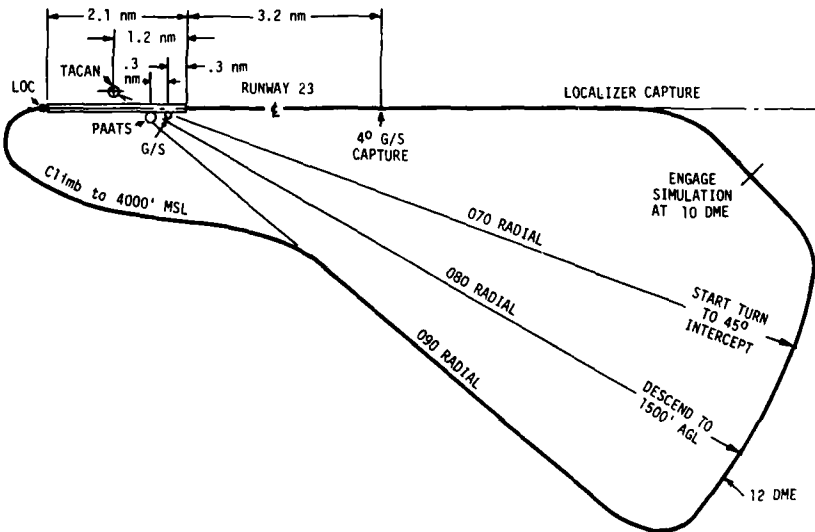

Fig. 5 Circuit Pattern for TIFS RPV Approaches

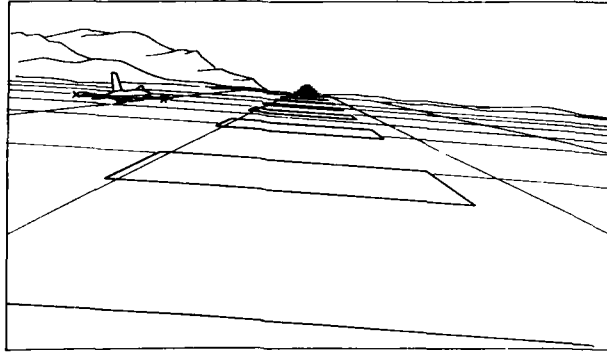

Fig. 8 CFPD Vertical Situation Display

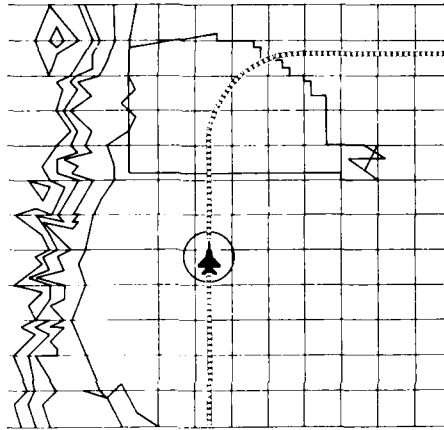

Fig. 9 CFPD Horizontal Situation Display

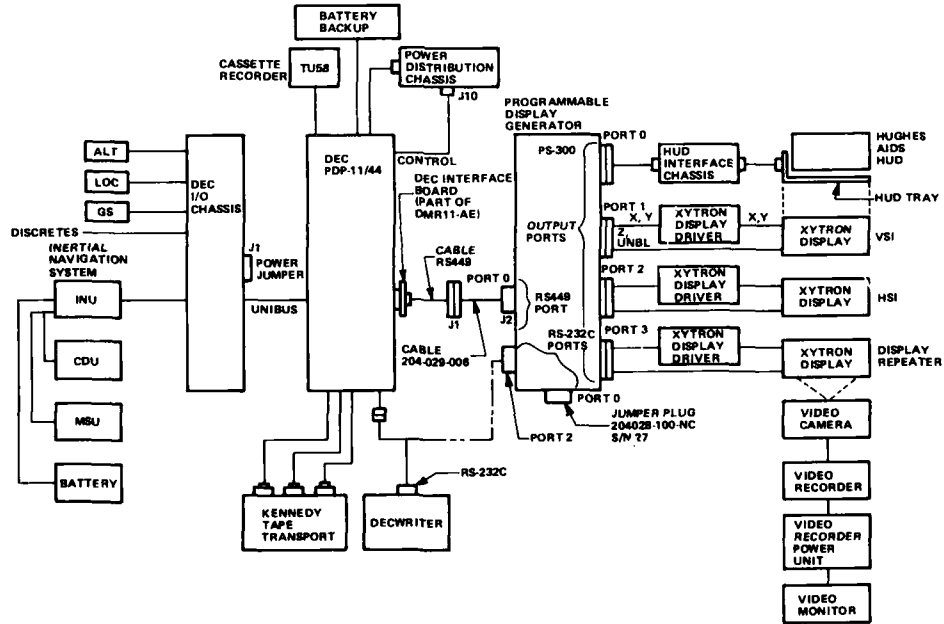

Fig. 10 CFPD Functional Block Diagram

**DFVLR IN-FLIGHT SIMULATORS ATTAS AND ATTHES FOR
FLYING QUALITIES AND FLIGHT CONTROL RESEARCH**

by

Dietrich Hanke and Gerd Bouwer
DFVLR — Institut für Flugmechanik
Postfach 3267
D-3300 Braunschweig
Federal Republic of Germany

SUMMARY

Two new in-flight simulators have been developed by DFVLR in recent years. There are the advanced airborne simulator ATTAS (Advanced Technologies Testing Aircraft System) based on a modified VFW-614 jet transport aircraft which will be operational in 1986. Further, the helicopter simulator ATTHes (Advanced Technologies Testing Helicopter System) based on a BO 105 helicopter, which is operated since 1984. Discussed are the potential of application, the design requirements, the vehicle modifications, the overall system performance and the simulation capabilities as well as the used model-following-control methods, showing that good simulation fidelity could be achieved.

INTRODUCTION

In order to meet the increasing demands on flight vehicle performance, reliability and economy, extensive use of advanced technologies is required. Especially in the field of active control and fly-by-wire technology the benefits are connected with additional problems due to complex system behaviour, complex failure modes and system related handling qualities problems. To minimize the development risk, a considerable lead in research and development is necessary. Beside ground based simulation and advanced computation methods flying testbeds for in-flight simulation as a technique have increasingly gained attention because the overall pilot/aircraft system can be investigated under real environmental conditions.

Based on the experience gained with the DFVLR-HFB 320 in-flight simulator, which was successfully used in various handling qualities flight experiments over the last decade (1-7), two new flying testbeds have been developed by DFVLR recently. There are the new advanced airborne simulator ATTAS (Advanced Technologies Testing Aircraft System) based on a VFW 614 jet transport aircraft (fig. 1), and a new helicopter simulator called ATTHes (Advanced Technologies Testing Helicopter System) based on a BO 105 helicopter (fig. 2).

PART I: ADVANCED TECHNOLOGIES TESTING AIRCRAFT SYSTEM (ATTAS)

1. ATTAS MISSION REQUIREMENTS

From the beginning ATTAS was designed as a flying testbed with a much more broader mission capability than it was provided by the classical in-flight simulators in the past. Simulating today's and future aircraft extends far beyond basic airframe parameters and dynamic modes to complete system behaviour in real mission environment. Due to the 'digital revolution' in aircraft flight control and aircraft systems, the overall system became increasingly complex, creating handling qualities which are much more influenced by system behaviour than ever before. Therefore ATTAS was designed to serve as a flying testbed and technology demonstrator covering the following missions:

Firstly, applied flight mechanics, guidance and flight control research and development using advanced equipment.

The research areas of DFVLR include (see also figure 3):

- o Flying Qualities - In-Flight Simulation
- o Flight Control - Active Control
- o Flight Guidance - Air Traffic Control
- o Navigation - Communication
- o System Modelling
- o Future Cockpit

Secondly, flight testing of advanced technologies, i.e. new modes or functions, new hardware and new subsystems.

The system testing capability includes (see also figure 4):

- o Avionics
- o Computers
- o Actuators
- o Sensors
- o Antennas
- o Data Link
- o Cockpit Controls and Displays

Additional requirements have been established by DFVLR which are related to system performance and flight test operation, like:

- o 5-DOF simulation capability
- o touch-down capability in the IFS-mode
- o fail-passive operational fbw-system
- o general purpose freely programmable on-board computer (high speed, large memory)
- o use of high order programming language
- o simple interface to the experimenter
- o software development system and real-time ground simulation capability for software validation
- o simple 'plug in' capability for additional subsystems

2. AIRCRAFT MODIFICATIONS AND EQUIPMENT

ATTAS is a modified VFW 614, twin-turboprop, short-haul 44-passenger aircraft of Vereinigte Flugtechnische Werke, Bremen. The production line was closed in 1978 after 19 aircraft had been built. Besides of ATTAS with the serial number 17, three aircraft are operated by the German Luftwaffe for German government VIP transportation.

The VFW 614 is ideally suited as general purpose testbed due to the size, cabin space, loading capability and flight performance. With full fuel about 3.5 tons of test equipment can be loaded. The flight performances with cruising altitude of 30,000 ft, maximum cruising speed of 285 kts CAS and a rather low landing speed of about 100 kts are very adequate for a large transport aircraft flight regime representation.

The project itself is managed by DFVLR with MBB (former VFW) as prime contractor. MBB is responsible for the basic aircraft modifications and the certification. The complete fbw-system, the onboard data processing system, avionics integration and the data acquisition system is under DFVLR's responsibility.

The main aircraft modifications and features are (see fig. 5):

- right hand seat safety pilot with conventional control system,
- left hand seat evaluation pilot with fly-by-wire controls,
- experimental flight instruments/displays,
- fbw-controls (column, sidestick) with artificial force-feel system,
- duplex digital on-board computer system with fibre optic data bus,
- duplex avionic-systems (laser gyros),
- data acquisition system, recording and telemetry,
- experimental cockpit (in the cabin),
- antennas installation provisions,
- Mil-Bus 1553 B linked electro-hydraulic self-monitored actuators, partly duplex,
- fbw-motivators for
 - o elevator,
 - o rudder,
 - o aileron (with symmetrical and antimetrical deflection capability),
 - o both engines,
 - o landing flaps,
 - o elevator trim,
 - o six direct lift flaps,
 - o flight spoilers,
- onboard operator consoles (four places).

2.1 ADDITIONAL CONTROL CAPABILITY

For 5-DOF inflight-simulation capability five independent control surfaces must be available. Therefore ATTAS was equipped with a special developed direct-lift system for pitch/heave motion decoupling and gust/load control. For low frequency DLC operation the basic VFW 614 landing flap system can be driven electrically between 1 to 14 degrees. The rear part of the landing flaps have been divided in six (three on each wing) fast moving flaps with about 75 deg/sec flap rate (with aerodynamic loads) and ± 35 degrees flap deflection for high frequency direct lift modulation. Both lift devices can be used simultaneously in a region of 1 to 14 degrees landing flap position. Further, DLC flap pairs can be controlled individually. The DLC lift modulation capability and flight envelope is shown in figure 6 and 7 demonstrating that DLC can be used also in the high speed region up to 285 kts.

Another important feature of the ATTAS fbw-flight control system is the symmetrical aileron actuation capability which will be used for wing bending mode control. Because the ailerons are mechanically connected with the safety pilot's controls, the symmetrical aileron deflections are compensated by a specially developed differential gear.

2.2 THE DATA PROCESSING SYSTEM

The on-board data processing system is the heart of ATTAS. It provides all the functions needed for system engagement and disengagement, the fbw-control laws and limitations, data comparison, data voting and experiment software functions. In-flight simulation for instance, with model and controller computation is such a typical experiment function.

The fbw-system includes the fbw-controls on the left hand side of the cockpit. The evaluation pilot commands are transmitted to the computer system which commands the numerous electro-hydraulic actuators. The computer system itself (fig. 8) consist of two computer channels with four computers in each channel and one separate central communication computer. The computers in each channel are linked by a serial fibre optic bus with high speed data transmission rate of 150 KWords/sec in a ring network structure.

The fbw-functions are distributed to the different computers. In the terminal computers (cockpit and aft fuselage) the measured aircraft states are preprocessed, compared and voted. In addition, they interface the avionics through ARINC 429 bus and the actuator electronics through the Mil-Bus 1553 B. The fbw-computer handles the control laws, the mode switching and the communication with the experimental control computer (ERR) in the simulation mode. The ERR will be used mainly for experiment function computation, therefore it is a sufficiently large freely programmable 32 bit computer with 1.4 MIPS capability and a memory which can be enlarged to 8 MBytes.

All computers, I-O and the fibre optic serial bus, are Mil-standard equipment. The data processing system is based on ROLM MSE/14 (Mil-Spec. Eclipse) 16 bit computers, while for the ERR the ROLM HAWK 32 bit computer is provided. All measured and computed data are handled by the central communication computer for on-board tape recording and transmission by PCM Telemetry to the ground station.

2.3 DATA ACQUISITION SYSTEM

The aircraft is equipped with all sensors which are necessary to measure the aircraft body rates, accelerations and attitudes as well as all control surface positions and engine data. Air data are calculated by two air data computers, inertial data by two laser gyro inertial reference units (LTN 90). Analog sensor outputs are conditioned (amplified, filtered etc.) in a specially developed signal conditioning system. A very important feature of this system developed by DFVLR is that all parameters for each channel can be set, checked, and electrically calibrated from a master computer (fig. 9).

2.4 ACTUATORS

One of the most important requirements was to have adequate simulation fidelity also in the highest eigenmotion frequency range of transport aircraft. Therefore high bandwidth electro-hydraulic series actuators have been developed for ATTAS by Liebherr Aerotechnik, (LAT). The high frequency response capability of the DLC actuators with simulated aerodynamic loads is shown in figure 10, indicating a bandwidth of about 1 to 10 Hz dependable of commanded amplitude.

In the primary control axes (elevator and rudder) the basic aircraft boosters are in series with the electro-hydraulic actuators. They have been modified to fulfil the requirement of no more than 24 degrees phase lag at a frequency of 1 Hz. The elevator channel frequency response shows that this requirements is met (fig. 11). The problem bandwidth (highest eigenmotion frequency of the model to be simulated) is about five times smaller than the actuator bandwidth. Further the control actuation phase lag is well below the Mil-F 8785 value of 30 degrees phase lag for the short period frequency region of about 0.2 Hz for transport aircraft.

All 15 actuators are self-monitored actuators where the monitoring device is realized by comparing actual valve position with a modeled valve. The actuators' microprocessor based electronics are housed in four boxes with duo-duplex Mil-Bus remote controllers (RTUs). Due to safety reasons, the elevator and rudder actuators are doubled with duo-duplex failure behaviour (one-fail op).

3. MODEL-FOLLOWING CONCEPT

The model-following system is based on the HPB 320 proven concept with additional features to improve simulation fidelity (fig.12).

The structure is "classical" with explicit on-board model computation and complete dynamic feed forward loops and low gain feed back loops. Due to increased computer power, real-time computation of much more complex models is possible. Further, precise actuator dynamics compensation is realized in the feed forward loops. For this purpose a special method was developed recently [8].

In addition, the measuring system dynamics and time delays will be considered in more detail to compensate phase lags between model output and actual measured aircraft data before the error is fed back. The plant dynamic parameters will be extracted from flight test data using DFVLR developed parameter identification methods [9]. The controller is optimized using vectorial cost function optimization methods developed by DFVLR [10]. After this step the controller will be tested in a complete ATTAS simulation providing detailed actuator characteristics. If the performance is adequate, the controller will be validated in the real-time ground simulation facility before it is flight tested.

4. GROUND SIMULATION

Essential part of ATTAS is the ground based ATTAS-simulator (fig. 13) which was designed at the beginning of the project. The ATTAS-simulator is a copy of ATTAS, simulating all system functions in real-time on the ground. The purpose of the ATTAS-simulator is to develop and validate the fbw-software as well as all user developed experimental programs. The ground simulation consists of an identical ATTAS-cockpit, a nearly identical computer configuration based on commercial Data General computers which are software compatible to the ROLM on-board system, the hybrid computer Pacer 600 and the multiprocessor system AD 10. The last two computers simulate the complete flight dynamics, actuators and sensor informations of the aircraft. All sensor informations are electrically and connector identical to the aircraft so that the flight test hardware can be plugged into the simulation. By this all in-flight computer programs can be developed and checked out on the ground under real-time conditions before they are transferred via magnetic tape into the aircraft. Further, for hardware-in-the-loop simulation, the aircraft in the hangar can be linked by the fibre optic bus with the ground simulator.

PART II: ADVANCED TECHNOLOGIES TESTING HELICOPTER SYSTEM (ATTHES)

1. ATTHES MISSION REQUIREMENTS

The ATTHES helicopter in-flight simulator of the DFVLR serves as a testbed in mainly three areas:

- o Handling Qualities Research
- o Future Cockpit Investigation
- o Flight Control System Design

These main areas of pilot-in-the-loop research for future helicopter systems require a large variability and flexibility of the system.

In helicopter handling qualities research ATTHES currently is used to investigate the effects of roll-to-pitch coupling on slalom manoeuvre performance at 60 kts and of roll-to-yaw coupling on sidestep manoeuvre performance in hover [11].

Since the dynamics of the helicopter-model to be simulated are different in these two tasks, the ATTHES system is capable to switch the model during the in-flight simulation.

For the flight-tests mentioned above, ATTHES is equipped with a center-stick. To meet the requirements of future cockpit research, sidestick(s) will be implemented in ATTHES and flighttested in 1986. In addition ATTHES is equipped with computer-graphic systems to drive modern CRT's for investigations on display systems.

The basic Model Following Control System (MFCS) is designed to meet the requirements of additional control modes, such as autopilot and automatic navigation functions.

2. HELICOPTER MODIFICATIONS AND EQUIPMENT

ATTheS in-flight simulator shown in figure 2 is derived from an MBB BO 105 helicopter. This six-seat helicopter is equipped with a hingeless fibre-glass rotor system, which leads to a high manoeuvrability.

The third series helicopter (BO 105 S-3) was modified to a fly-by-wire helicopter. In the new arranged two-seat cockpit (fig. 14) the safety-pilot is flying the helicopter with conventional controls from the left-hand seat in the rear. The mechanical controls of the evaluation pilot, sitting in front in the middle of the ATTheS cockpit, are fitted with electrical position transducers and a force feel system. Connected to the electro-hydraulic actuators, which are mechanically linked to the safety pilot's controls, the evaluation pilot flies ATTheS.

The BO 105 S-3, owned by the DFVLR since 1982, was further equipped to meet the requirements of ATTheS. Additional avionics and sensors and a 32 channel data acquisition system was implemented. For data storage an analog tape recorder was installed and the FM/PCM telemetry enables a quick flight test analysis by stripchart recording, digitizing and displaying the data in a mobile ground station.

As an onboard computation (fig. 15) system three parallel working PDP computers were chosen. All computers are equipped with a 256 kByte RAM, the serial interfaces, line-time clocks and a dual port memory for interconnection to a second computer. The operating system and tasks of all computers are permanently stored in bubble memories and automatically started in a power up sequence.

The data and control computer handles all the I/O procedures, such as A/D and D/A converting and control the data transfer between the computers. The control computer includes the control algorithms of the MFCS. The third computer is at the experimenter's disposal. As mentioned above, it is easy to program and of the same high computational capacity as the other computers.

3. ATTheS MODEL FOLLOWING CONTROL SYSTEM

In general, the MFCS for ATTheS is the same as in ATTAS (fig. 12). Due to the specific helicopter characteristics, such as

- o helicopter nonlinearities,
- o helicopter couplings,
- o actuator nonlinearities,
- o parameter uncertainties,

the general MFCS-scheme was extended to deal with these problems. The robust control system consists of linear, nonlinear and a new controller optimization feature [12] to operate over the complete flight envelope of ATTheS.

The main objective of the designs ATTheS-MFCS shown in figure 16 is to control the attitudes to be followed in the outer loop by controlling the rates in the inner loop. The feedback matrices, G_1 and G_2 , are used by the designer to select the desired outer-loop and inner-loop states to be controlled. The elements of G_1 and G_2 are either 1's or 0's, and each matrix contains a maximum of four elements equal to 1 (the number of states to be followed must equal the number of controls available). Once G_1 and G_2 are defined, the controller matrix G_c is dependent only on the base system's control matrix B_0 for the four commanded variables. The controllers used are feed-forward gains calculated using a non real-time identification procedure which incorporates a linearized version of the actual helicopter. In addition, the elements of the controller matrix are adjusted with airspeed to improve the accuracy and robustness of the system. The output of the controller matrix is integrated to suppress constant errors and hold the base system in the trim state over the whole flight envelope.

4. ATTheS GROUND SIMULATION CAPABILITY

To reduce the probability of system failure by programing mistakes and to familiarize the pilots with the ATTheS system and flight task, two different real-time ground simulations are part of the in-flight simulation procedure.

During program implementation on the experimenter's computer, the ATTheS computer-system is interconnected to a laboratory simulation, including joysticks and the ATTheS Multi-function Display (MFD). As in the ground simulation, the ATTheS data and control computer runs a helicopter realtime simulation. The control computer and the experimenter's computer get the data, as in an in-flight simulation. In this phase, the experimenter is already able to check his software and estimate the effectiveness of the in-flight simulation.

When the computation system is implemented in ATTheS (fig. 15), a ground simulation has to be performed. When ATTheS is interconnected to an external electrical and hydraulical power supply, both, the evaluation pilot and the safety pilot have to 'fly' the in-flight simulation task. Especially the safety pilot is able to estimate the simulation performance by comparing the activity on his controls with the displayed states on the MFD.

5. ATTHEs FLIGHT TEST RESULTS

In May 1985, first flight tests with helicopter in-flight simulation were conducted. The model to be simulated was represented by a partial nonlinear 8 DOF mathematical model of a PUMA helicopter excluding its SAS. This helicopter was chosen, because its main rotor turns clockwise, while the BO 105's rotor is turning counterclockwise. This results in different couplings; as the response to a collective-up pilot's input, the PUMA would climb, pitch up, roll left and yaw left, while the BO 105 would roll right and yaw right.

Simulating the PUMA, the MFCS not only has to decouple the base helicopter, in addition, by manipulating the fly-by-wire actuators it has to achieve this opposite coupling. The vehicle states, controlled by the MFCS are the vertical velocity, all angular rates and pitch and roll attitude.

The time histories of an ATTHEs in-flight simulation of the PUMA are shown in figure 17. The upper diagram shows a 5% collective step input for 3 seconds to the PUMA mathematical model. The lower histories represent pitch attitude, roll attitude and vertical velocity of the PUMA model (dashed lines) compared with ATTHEs time response (solid lines). It can be seen, that, augmented with the MFCS, ATTHEs is very well able to follow the PUMA's response, although the model's couplings are opposite to the base BO 105 helicopter.

6. CONCLUSIONS

With the new developed in-flight simulators ATTAS and ATTHEs powerful research and development tools are available at DFVLR. Equipped with modern computer systems, actuators avionics and advanced model-following control techniques adequate in-flight simulation fidelity and subsystem testing capability are provided. The dual-redundant fly-by-wire flight control system of ATTAS will extend the in-flight simulation flight envelope to actual touch downs in the near future.

Especially developed facilities for extensive real-time ground simulation of both research vehicles provide effective software development, software validation and flight test preparation.

7. REFERENCES

1. Hamel, P., Wilhelm, K., Lange, H.-H., "Steep Approach Flight Test Results of a Business-Type Aircraft with Direct Lift Control", AGARD-CP-160, 1974.
2. Hanke, D., "In-Flight Investigation of Direct Lift Control in Landing Approach", DFVLR-IB, 1977.
3. Hanke, D., "In-Flight Handling Qualities Investigation of A 310 Airbus DLC-Configurations on Landing Approach using the DFVLR HFB 320 In-Flight Simulator", DFVLR-FB 79-18, 1979; ESA-TT-630, 1980.
4. Hanke, D., Wilhelm, K., Lange, H.-H., "Handling Qualities Aspects of CTOL Aircraft with Advanced Flight Controls", AGARD-CP-333, 1982.
5. Hanke, D., "Flying Qualities Experiments of Rate Command/Attitude Hold Systems in the HFB 320 In-Flight Simulator", DFVLR-FB 83-25, 1983.
6. Wilhelm, K., Altenkirch, D. "In-Flight Investigation of Effects of Time Delay in Control Systems on Flying Qualities in Landing Approach", DFVLR-FB 84-35, 1984.
7. Wilhelm, K., Schafranek, D. "In-Flight Investigation of Landing Approach Flying Qualities of Transport Aircraft with Relaxed Static Stability ", DFVLR-FB 84-11, 1984.
8. Henschel, F., "Über Regelungskonzepte zur In-Flight-Simulation unter Berücksichtigung von Nichtlinearitäten und Totzeiten in den Stellsystemen", DFVLR-FB 85-24, 1985.
9. Plaetschke, E., "Estimation of Flight Mechanical Variables by Means of Kalman Filters", ESA-TT-831, 1984.
10. Kreisselmeier, G., "Reglerentwurf mit vektoriellen Gütekriterien und seine Anwendung zur Stellgeschwindigkeitsreduktion bei parameterempfindlichen Reglern", DLR-FB 77-55, 1977.
11. Pausder, H.J., "A study of roll response required in a low attitude slalom task", 11th European Rotorcraft Forum, London, 1985, No 79.
12. Hilbert, K.B., Bower, G., "The Design of a Model-Following Control System for Helicopters", AIAA No 1941, AIAA CP848, 1984.

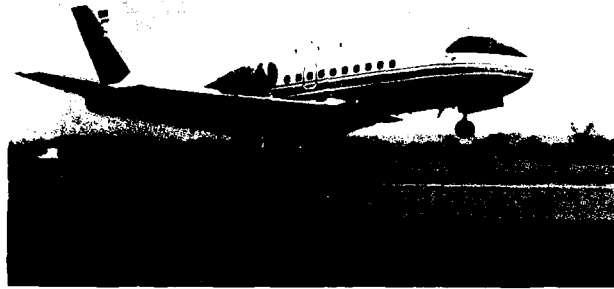

Fig.1 ATTAS in flight



Fig.2 ATThES in flight

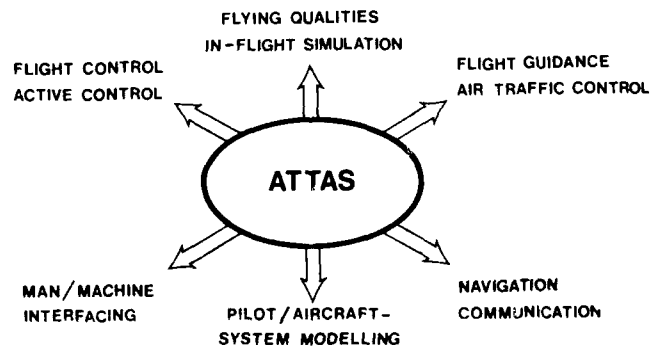

Fig.3 ATTAS R&D utilization

AD-A173 875

FLIGHT SIMULATION(U) ADVISORY GROUP FOR AEROSPACE
RESEARCH AND DEVELOPMENT NEUILLY-SUR-SEINE (FRANCE)
A M COOK ET AL. SEP 86 AGARD-CP-408

4/4

UNCLASSIFIED

F/G 5/9

NL

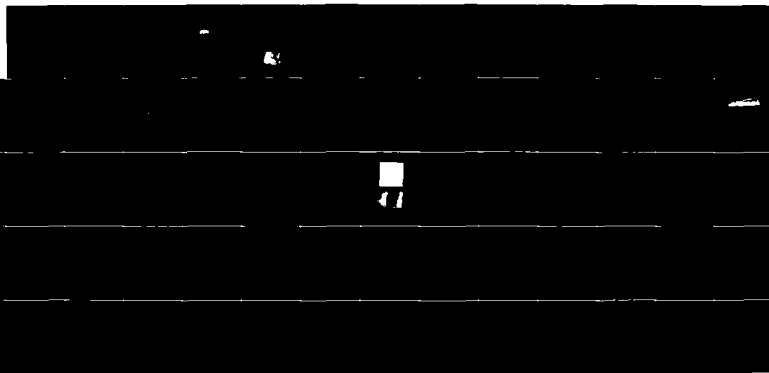

END
DATE
FORM
1-78

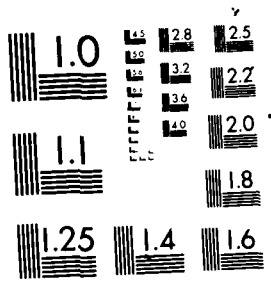

MICROCOPY RESOLUTION TEST CHART
NATIONAL BUREAU OF STANDARDS 1963-A

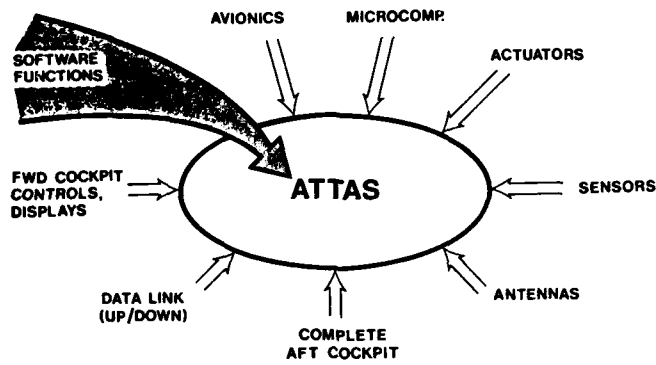

Fig.4 Hard-Software testing capability

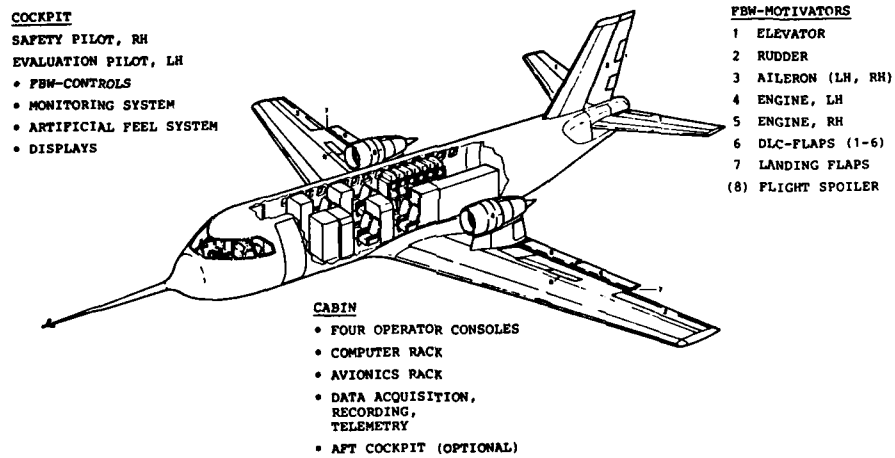

Fig.5 ATTAS modifications

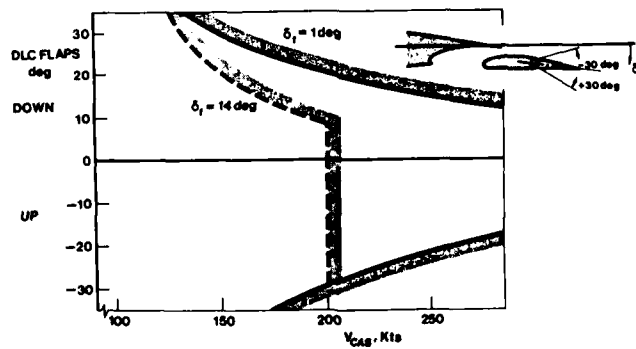

Fig.6 DLC flight envelope

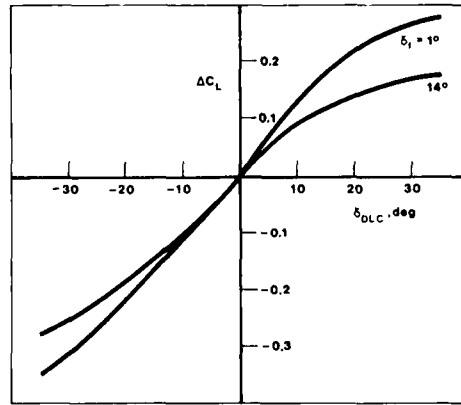

Fig.7 Direct lift modulation capability

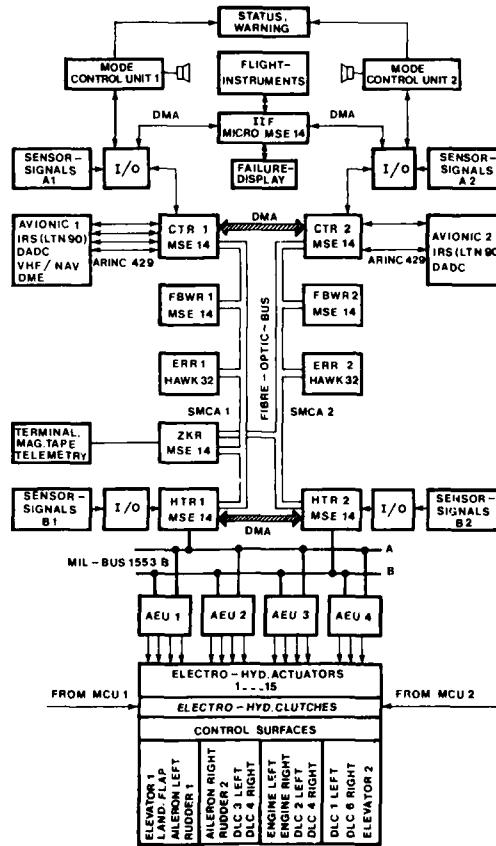

Fig.8 ATTAS-dual-redundant fly-by-wire flight-control-system

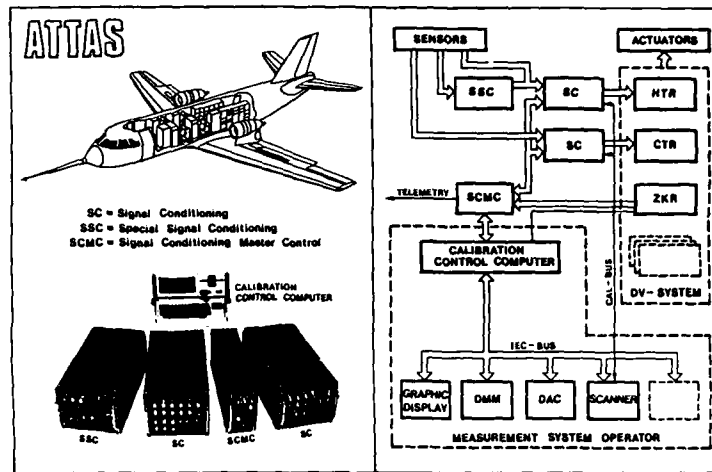

Fig.9 Data acquisition system

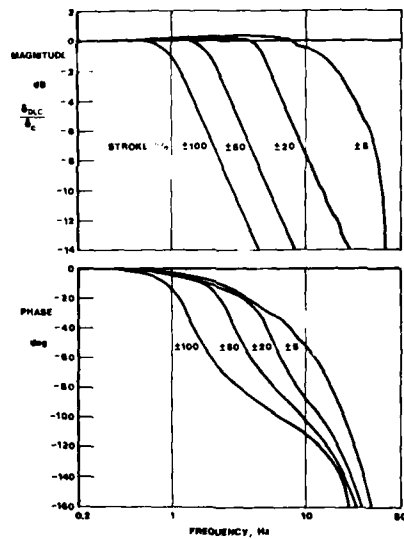

Fig.10 Measured DLC-actuator frequency response (loaded)

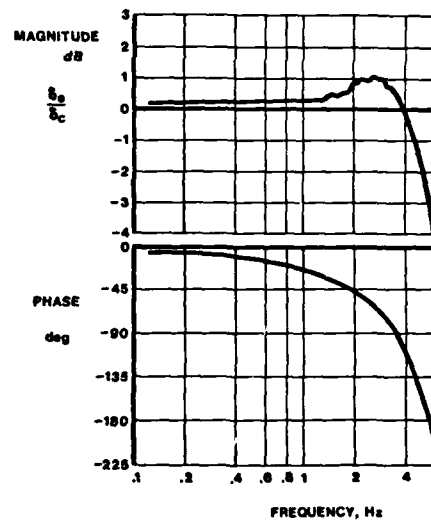

Fig.11 Frequency response of elevator control channel (series and booster actuator, unloaded)

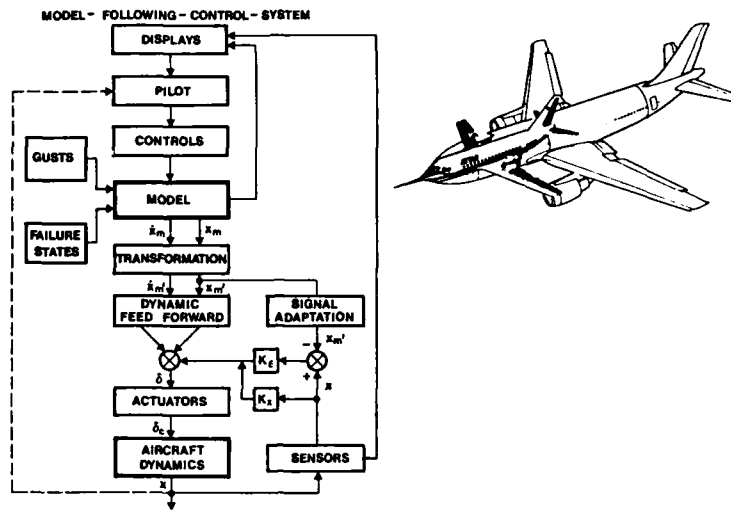

Fig.12 ATTAS model-following control scheme

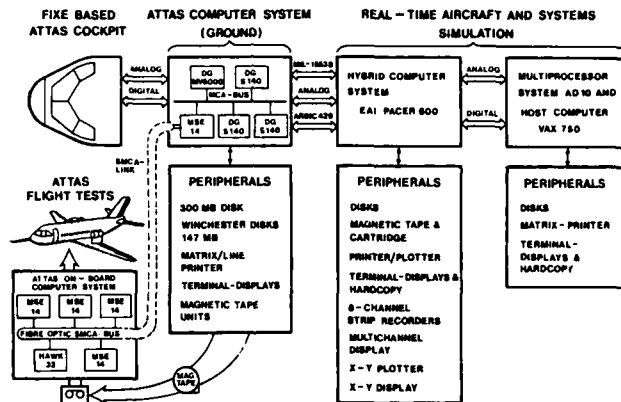

Fig.13 ATTAS real-time simulation facilities

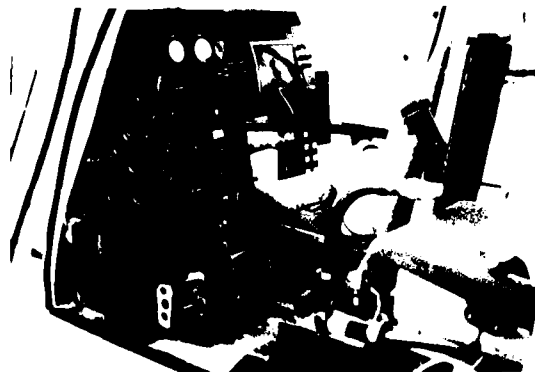

Fig.14 ATTAS cockpit configuration

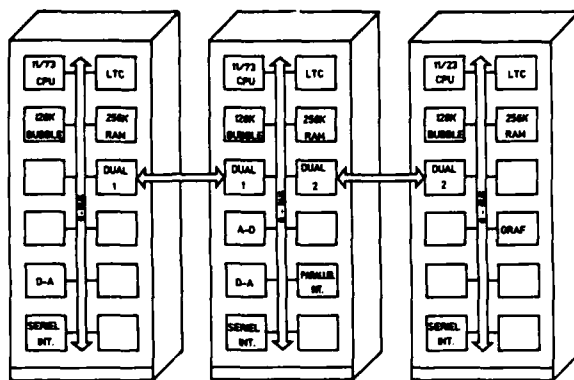
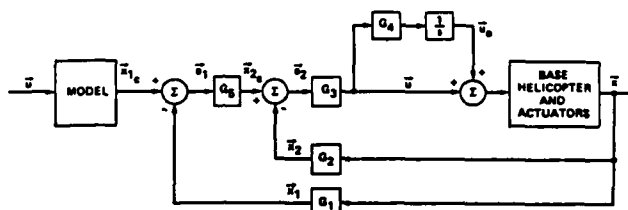

Fig.15 ATHeS on-board computer system



$$\vec{u} = (\delta_{Long}, \delta_{Lat}, \delta_{Coll}, \delta_{Tailr})^T$$

$$\vec{x} = (u, v, w, p, q, r, \phi, \theta)^T$$

$$\vec{x}_1 = (\theta, \phi, 0, 0)^T$$

$$\vec{x}_2 = (q, p, w, r)^T$$

Fig.16 ATHeS model-following control system

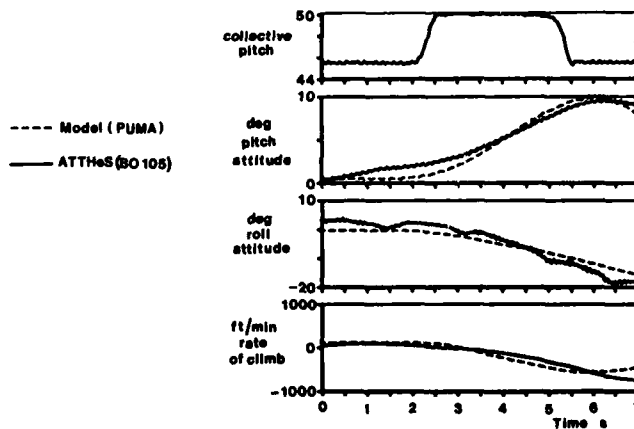

Fig.17 PUMA in-flight simulation with ATHeS (climb manoeuvre)

**DEVELOPMENT OF IN-FLIGHT SIMULATION AIRCRAFT
FOR RESEARCH AND TRAINING APPLICATIONS IN UK**

by

Mr O.P.Nicholas
FS(B)1 Division
R.A.E.
Bedford MK41 6AE, UK

Sqn Ldr J.A.Giles
Empire Test Pilots School
A & AEE - Amesbury
Wilts SP4 0JF, UK

and

Mr D.A.Williams
College of Aeronautics
Cranfield University of Technology
Cranfield, Beds MK41 0AL, UK

INTRODUCTION

In the UK the Ministry of Defence has recently launched two separate programmes involving in-flight simulation. One of these programmes is for research using a Harrier, the other for training using a Hawk. Although the objectives are different, there are considerable similarities in the philosophies adopted for the experimental systems in the two aircraft. One organisation, the Cranfield Institute of Technology, (CIT), is doing the work to modify both aircraft.

This paper is in three sections by three authors.

1. -The objectives and aircraft experimental system for the RAE VAAC research programme by O P Nicholas.
2. -Similar information on the ETPS ASTRA Hawk programme, by Sqn Ldr J A Giles
3. -CIT design, installation, test and clearance work on the aircraft for both programmes by D A Williams.

1. VAAC

OBJECTIVES

VAAC is an acronym for Vectored thrust Aircraft Advanced Flight Control. This is a programme of research into control laws, displays and inceptors (cockpit controls) for advanced VSTOL aircraft. The objective is to develop concepts, and design and assessment techniques; through mathematical studies, ground based piloted simulation and flight in a two seat fly-by-wire research Harrier at RAE Bedford. This work aims to free the designer from some of the traditional stability and control constraints, and to maximise operational effectiveness throughout the flight envelope of VSTOL aircraft.

Compared with conventional aircraft, VSTOL configurations have an additional degree of freedom since, whatever their physical arrangement, the direction of overall thrust can in some way be varied. They also operate down to zero dynamic pressure. These features present unique challenges and opportunities which the VAAC programme seeks to grasp. The pilot must be able to communicate his requirements via his inceptors, and the control system must ensure that he can utilise the aircraft's full performance potential. The system should provide carefree handling and permit the pilot to recognise the aircraft's capabilities and limitations. It is important to note that carefree handling can conflict with operating flexibility.

Fig 1 illustrates the development path for flight control concepts. The VAAC programme is indicated by solid lines. It contains three elements:

- i. *Off-line studies*
- ii. Piloted simulation - to focus on the new Advanced Flight Simulator (AFS) at RAE Bedford
- iii. Flight - in the VAAC research Harrier at RAE Bedford.

Initial control concept development goes from off-line studies to ground based piloted simulation and loops round until satisfactory. The next phase involves flight in the VAAC Harrier and further looping through off-line and piloted simulator studies.

The aim of the VAAC programme is to establish confidence in the process indicated by the thick solid arrows. This will then give confidence to tread a similar path, plus the thick dotted arrow, leading to flight and operation of an advanced VSTOL aircraft. Once this is flying fine tuning can, of course, follow the path of the thin dashed lines.

The VAAC programme will initially study the control of the Harrier as such. Later it will move to studying on the ground based simulator, and mimicking in the Harrier, the handling and control limitations which in general go with the improved performance of advanced VSTOL designs.

THE VAAC AIRCRAFT AND SYSTEM

The aircraft selected for the flight element of the VAAC programme is the RAE research two seat Harrier, serial number XW175 (Fig 2). This is an early Harrier whose basic airframe and systems have now been brought to near current RAF standard to ease engineering support in the years ahead. There has also been an equipment weight and space saving exercise to permit the installation of the VAAC research system.

The VAAC installation has been designed to provide flexibility for control concept research. The major flight control questions for advanced STOVL aircraft lie in the longitudinal plane.

The research pilot is in the rear cockpit. This has:

Stick disconnected in pitch - sensor and artificial feel added.

Throttle and nozzle levers disconnected - sensors added.

Option of new inceptors.

Digital computer driving:

- Full authority - pitch control system
- throttle
- nozzle angle
- flap (existing actuator)
- Limited authority - roll control system
- yaw control system (existing series actuators)

Programmable Head-up Display (HUD).

The pilot in the front cockpit acts as a safety pilot. We plan to fly only in good visibility by day. He has the best field of view, which will not be upset if the rear (research) pilot is behind screens to simulate instrument flight conditions. He has a programmable HUD. His cockpit inceptors retain their normal links with the motivators and are back-driven by the VAAC (FCS) or directly by the rear pilot. He should not be able to distinguish the VAAC system from a human pilot in the rear seat of a standard Harrier. His inceptors will reflect the VAAC outputs, putting him in the best possible situation to monitor the VAAC system's behaviour.

The VAAC FCS arrangement has been selected to suit a research programme involving experimental control laws which will be changed frequently. We cannot afford the time and effort to ensure that there will be no problems due to:

- (a) immature control laws, or
- (b) immature software code.

We anticipate that software problems will be much more frequent than hardware failures. This establishes the basis for the system selected:

Simplex control law computing.

No attempt to achieve a failure survival experimental system.

Revert to safety pilot following any failure.

Therefore only fly within manual recovery envelope, i.e. smaller envelope than conventional Harrier.

The VAAC pitch, throttle and nozzle servos are connected through clutches to the standard mechanical control runs. These clutches disengage if the safety pilot detects a failure and either opposes the motion of his inceptors or operates one of the disengage switches. He is assisted by an automatic failure detection system which can also disengage the clutches. This system has three elements:

- (a) Critical sensors are duplicated and cross monitored, other sensors are checked for short term credibility.
- (b) Servos are either duplex or monitored against a mathematical model.
- (c) An Independent Monitor within the flight control computer checks that the aircraft remains within an envelope that permits safety pilot recovery and that structural limits are safeguarded.

The various elements of the VAAC system have been selected, as far as possible, to be off-the-shelf production items. The aim has been to ensure good long-term support and to avoid having experimental hardware as well as experimental control laws and displays.

These considerations, among others, lead to the selection of a flight control computer provided by Smiths Industries. This is based on their Flight Management Computer for the A310 Airbus. The computer has:

120 analogue inputs
 4 off 8086 processors and 2 off 8087 coprocessors
 giving 400 K ops/sec for control law calculations
 250K 16 bit words of ROM plus 24K of RAM
 17 analogue outputs
 2 off 8086 plus 1 off 8087 for the Independent Monitor.

The experimental programmable HUD system in the aircraft is virtually identical to that in the Bedford AFS simulator. Previous experience has taught us the value of having the same hardware and software in ground based simulator and flight.

The aircraft is fitted with a telemetry based data recording system. This permits flight safety monitoring of raw and on-line processed data, and provides the basis for comprehensive post-flight analysis.

TIMETABLE

For some years VAAC off-line and ground based piloted simulator control and display studies have been under way at a range of establishments. From the end of 1985 these will be focused on the new RAE Bedford AFS simulator as the programme builds up towards flight.

Harrier XW175 went to CIT at Christmas 1983 and is due to return to Bedford in spring 1986. By then the VAAC system installation will be complete and it will have been ground tested. However, CIT are only required to clear the aircraft in flight with the VAAC system switched off. After XW175 returns to Bedford we shall clear the use of the VAAC system in flight, progressively expanding the flight envelope using a digital representation of the standard Harrier flight control system. This work can only be done in flight and relies heavily on the safety pilot. Its end point will be the derivation of suitable settings for the Independent Monitor and the determination of the safety pilot's capabilities.

We anticipate that flights with experimental control and display laws will start by the end of 1986.

2. ASTRA HAWK

BACKGROUND

A competent test pilot must be capable of flying an aircraft having unknown flying qualities, of assessing the deficiencies of a particular design, and of communicating with design engineers so that these deficiencies may be identified and rectified quickly and economically. An important aspect of his responsibilities is to judge when it is prudent to withdraw from an unusual flight condition, or when it is safe to continue in the interests of gathering information. A primary objective of the Empire Test Pilots' School, Boscombe Down, is to provide prospective test pilots with the first hand experience of flying aircraft possessing a broad range of flying qualities. Conventional aircraft are used for this purpose but they do not generally exhibit the more undesirable (and therefore more interesting) characteristics, since these will normally have been corrected during initial development.

Although aircraft handling experience is supplemented by the use of ground based simulators, these leave much to be desired. This is particularly apparent in marginal handling conditions, when the pilot may require accurate visual and motional feedback cues in order to maintain control of the simulated aircraft. It is also an essential part of test pilot training to teach the pilot to relate a particular handling quality to a given mission. This is obviously much easier to do in the air than in a simulator.

A variable stability aircraft is essentially an airborne simulator in which the student's pilot controls are isolated from the aircraft control surfaces, and his demands are used to control the aircraft indirectly. At the same time the natural flying qualities of the host aircraft are modified so as to simulate those of another. Such an aircraft which reproduces visual and motional cues precisely can enable a potential test pilot to gain first hand experience of a wide range of aircraft handling qualities in a single flight, and assess the impact of these characteristics on closed-loop mission orientated tasks. An important feature of a variable stability aircraft is the flight safety monitor, which ensures that the aircraft operates in its simulation mode only within a safe, predetermined flight envelope. This enables handling qualities to be varied beyond the point at which the simulated aircraft ceases to be controllable.

CURRENT TRAINING AIRCRAFT

The Empire Test Pilots' School currently uses a modified Basset aircraft to demonstrate variable stability characteristics to the students. This aircraft was modified by Cranfield in 1972 and uses an analogue computer to feed inputs into electrical actuators. Control of the aerodynamic derivatives is by analogue pots situated between the side by side seats. The students control stick and rudder pedals have a simple spring and damper feel system which gives the student a force feel dependent on the control displacement. The Basset, being a modified transport aircraft, has a very limited flight envelope under VSS operation. For example, the speed range is between 110-160 kts, the allowable sideslip is $+8^\circ$, and the normal g limit is +2. There are also safety features which cut the system out if the student moves his controls quickly. Thus, while the

Basset is valuable for demonstrating varying open loop characteristics, its application is very limited when assessing the closed loop handling problems associated with them. Also, the Basset is only cleared for VSS operation above 3000 ft, which restricts feedback cues, and does not allow the students to look at handling characteristics in all role-relatable flight regimes. The high speed and small size of current digital computers has allowed us to progress straight from an analogue controlled analogue computer to a digital controlled digital computer, which will give us a great deal of flexibility in structuring future flight programmes.

THE HAWK AIRCRAFT

The Hawk aircraft is a single engined design featuring twin hydraulic systems and hydraulic actuator control of the ailerons and elevator surfaces. Its performance envelope is shown in Fig 3. The Hawk has a very useful range of normal acceleration and a good top end speed. The proposed VSS envelope is in the range to +7g and -2g up to 500 kts.

The Hawk (Fig 4) has many good features to commend it. It is very economical on fuel, has good climb performance and has an excellent, tight, flight control system. However, it also has some obvious limitations for use as a variable stability trainer. Firstly, it is small, which requires considerable engineering expertise to fit all the VSS control elements within the airframe. Secondly it features a tandem cockpit, which means that the instructor cannot see the control movements made by the student, as his stick and rudder pedals only reflect the actual response of the aircraft controls to the student's input. We are hoping to overcome the problem by fitting a display, in analogue form for positions, and digital for force, which has been modified to illustrate the control movements and forces being applied by the student.

Fortunately, the field of view from the rear seat of the Hawk is excellent (Fig 5), and this enabled the decision to be made early on in the programme to use the rear seat as the instructor's seat and to put the student in the front, thus putting him in the most realistic simulation environment possible.

SYSTEM PERFORMANCE

With the increasing use of closed loop test techniques to define specification requirements and aircraft handling qualities, it was recognised that the VSS Hawk would have to be more than a simple variable stability trainer. The Hawk will possess all the classical variable stability characteristics such as variable short period and phugoid frequency and damping, variable static and manoeuvre stability, variable stick force per g, variable roll to yaw ratios and accelerations, variable static directional and lateral instability, spiral mode time constant and Dutch roll characteristics. The aircraft can be controlled through a centre stick featuring fully variable feel characteristics or a fixed side stick controller which is slightly compliant. All mechanical characteristics will be able to be varied for the centre stick and rudder pedals, and in addition the electrical input from the inceptors can be moulded with respect to the computer output. Rate demand, g demand and angle of attack demand systems will also be able to be simulated. Although we are using a digital computer we trust that our transport delay will be absolutely minimal and we will therefore plan to vary it to show degraded handling qualities. The on-board displays are an essential and integral part of the VSS systems. The aircraft is equipped with a head-up display and a colour multi-function display. The head-up display will be software controlled and the generated displays will be variable in flight. They will include the ability to change the pitch bar gearing from 1 to 1 to 5 to 1, and to vary the methods of presenting a pitch bar display during climbing and diving manoeuvres. In addition the velocity vector symbol on the 1 to 1 display will have a variable quickener which will enable the visual feedback of flightpath to be varied as the aircraft dynamic responses change. The HUD will also display a target tracking task using a generated symbol which will be moved around the display under software control to provide a repeatable high gain task for the pilot to fly, and against which he can compare varying aircraft configurations. Both cockpits are fitted with a multi-function display and, in addition to displaying the usual attitude information and navigation displays, they will be capable of displaying system parameters which will enable the instructor to monitor and change any of the aerodynamic derivatives or mechanical characteristics displayed. They will also display a graphical representation of the aircraft's response to an input in essentially real time.

SYSTEM ELEMENTS

The variable stability system comprises a number of discrete elements, as shown below:

- a. A set of transducers to measure aircraft parameters and loads.
- b. A Signal Conditioning and Interface Unit to condition transducer measurements, to drive Electro-Hydraulic Servo Valves, to control the supply of hydraulic fluid to the system. The Signal Conditioning Unit is mounted in the right-hand console of the front cockpit.
- c. A Flight Control Computer, consisting of a Simulation Computer and a Flight Safety Monitor. The Flight Control Computer is mounted in the Avionic Bay underneath the rear cockpit.
- d. A Head Up Display mounted in the front cockpit.

- e. A Multi-Purpose Display mounted in each cockpit.
- f. A Flexible Air Data System mounted in the Avionic Bay.
- g. A small CRT display in each cockpit to display positions of, and loads applied to, the student's controls.
- h. A Head-Up Display Computer, modified to drive the multi purpose displays and to communicate with the Flight Control Computer; this is mounted in the Avionic Bay.
- i. A Side Stick Controller is mounted on the right hand console of the front cockpit.

A digital magnetic tape recorder is mounted aft of the Avionic Bay to record all the required aerodynamic and aircraft parameters. A diagram of the electronic system is shown in Figure 6.

Finally an Electro-Hydraulic Actuator pack is mounted in the front cockpit control console. The pack comprises three linear actuators, one attached to each axis of the student's controls which simulate feel, and three rotary actuators, one attached to each of the control rods (which are normally attached to the student's controls). These move the existing aircraft control rods, to control the normal control surface hydraulic actuators. A diagram of the hydraulic system is shown in Figure 7.

3. CIT MODIFICATIONS TO VAAC AND ASTRA AIRCRAFT

PRINCIPLES

The two aircraft which are the subject of this paper were designed by the same division of British Aerospace. In all other respects, however, it would be difficult to find two aircraft which were less similar. Likewise, the purposes of the modification programmes which are being carried out at CIT are quite different. The VAAC programme is designed to provide a vehicle for research into aircraft control laws, whilst the ASTRA programme is intended to provide a vehicle for test pilot training.

From the systems point of view, however, the design requirements of the two flight control systems contain remarkable similarities.

For example:

- Both control systems were required to be digital.
- In both cases, pilot input demands were to be used, together with measurements of aircraft response, to create drive signals for actuators attached to the normal aircraft controls.
- In both cases the aircraft were required to operate safely when deficient, or even unmanageable, control laws were invoked.

The last requirement, in particular, had a major impact upon the design of both systems. It implied two pilot operation, with the controls of one pilot operating normally, but with those of the second pilot operating the motivators only via the flight control system.

The requirement also implied the presence of a "Flight Safety Monitor" (FSM) (termed Independent Monitor in the VAAC aircraft) to ensure that the second pilot could operate the aircraft only within a pre-determined flight envelope. The FSM was to be capable of disabling the flight control system in the event of an envelope transgression, thereby returning control to the first pilot (safety pilot, or instructor). Safety considerations dictated that no single failure within the monitoring system could place the airframe at risk.

If the principle of monitoring aircraft "States" is extended to include monitoring the performance of the flight control system itself (including actuation), then the presence of redundancy in the flight control system itself becomes something of an expensive luxury (at least for the purpose of ensuring flight safety). The philosophy of simplex control actuation, and duplicate monitoring of flight safety has been employed in the design of both flight control systems.

The philosophy has allowed major reductions in hardware costs and, in the case of VAAC, offers the prospect of investigating experimental control laws in a realistic environment without the need for exhaustive (and expensive) simulations prior to flight. So far as ASTRA is concerned, the philosophy admits the prospect of demonstrating the effect of handling deficiencies safely whilst operating within a broad manoeuvre envelope.

IMPLEMENTATION

In both cases the flight control systems comprise a number of transducers, a transducer signal conditioning unit, a digital computer and a number of control surface "motivators". The similarities, and differences, between the elements of the two systems are discussed below.

Transducers.

Common transducers include measurements of aircraft "State" (the three components of c.g. acceleration and angular rate, aircraft attitude in pitch and roll, height, airspeed, incidence and sideslip). Both systems incorporate "inceptor" and "motivator" position transducers. The VAAC system incorporates front cockpit (safety pilot) pitch inceptor load sensing (corrected for inertial components) for disengagement purposes. The ASTRA system incorporates front cockpit (student) centre stick (two axes) and rudder pedal, load measurement and artificial feel. A "side-stick" controller is installed as standard, incorporating load cells in both axes. The ASTRA system also measures flying surface loads (for fatigue assessment).

The VAAC system uses duplicated transducers, wherever possible, to enable measurements to be validated directly without imposing the large computational load of a full Harrier model, with its complex engine/airframe interactions, upon the FSM. In the ASTRA system reductions in installation complexity, size/weight of the SCU, and the number of ADC multiplexor channels are achieved by adopting the principle of simplex transducers. Transducer validation is effected by programming the FBM to execute consistency checks using groups of transducers. One exception is the adoption of duplicated strain gauges for measuring pilot applied loads.

Signal Conditioning Unit.

The SCUs in both aircraft contain transducer conditioning boards, together with actuator and display drive boards. Common designs, developed by CIT, are used for the various elements. In both cases, the SCU is divided into two independent partitions, each with its own set of power supplies, in order to preserve independence of duplicated transducers.

Differences between the two units reflect differences in transducers, actuators and displays.

Flight Control Computer.

The Flight Control Computer, in both cases, is logically divided into two independent partitions, one executing control law code and the other executing FSM code designed to ensure safety of flight. Common peripherals attached to the FCCs include an ADC sub-system, a number of DACs, discrete I/O channels, ARINC 429 interfaces, and a "watch-dog" timer.

In both cases, the ADC sub-system operates independently of the processors, sampling analogue channels in a fixed sequence and storing (12 bit) samples in RAM. An interrupt is generated at the start of each frame in the VAAC system, at the end of each frame in the ASTRA system. The interrupts are used to synchronize code execution.

The "watch-dog" timer is arranged so that disengagement will occur automatically unless both logical computing elements issue a reset signal at pre-determined intervals. This ensures that engagement will continue only if both the flight safety and the control law elements are functioning. In addition, both computing elements can effect disengagement directly by setting a discrete output channel. The VAAC system includes a separate sub-system to model the various control actuators. Significant discrepancies between computed and measured responses, detected by analogue comparators, cause automatic disengagement. Finally, either pilot can disengage the system by depressing conveniently placed buttons.

The digital computers used in both systems are based upon multiple sixteen bit micro-processors, each with its "own" RAM and EPROM. Communication between processors is mainly via global RAM. The VAAC system uses a total of six 8086 micro-processors and three 8087 coprocessors.

Both systems incorporate a digital measurement output stream. The VAAC system outputs via ARINC 429 links to PCM telemetry unit. The ASTRA computer generates a PCM bit stream internally, which is routed to an on-board magnetic tape recorder.

The VAAC system is controlled by the "research" pilot, in the rear cockpit, using a purpose-designed control panel. This provides controlled access to selected parameters using panel mounted potentiometers, switches and a keyboard, plus analogue and digital indicators. The flight control computer is linked by a digital highway with a display computer which can present different displays on the front and rear cockpit HUDs.

The ASTRA system is controlled by the instructor, also in the rear cockpit, using a Multi-purpose colour Display (MPD) and a keyboard. These are part of a Display Suite which includes an MPD and keyboard in each cockpit and a HUD in the front cockpit. The HUD computer includes a processor to communicate with the FCC and to generate alpha-numeric and graphic displays to each MPD. The Display Suite is designed to provide each MPD with ADI, HSI, and "VDU" modes. The required mode for each cockpit can be selected by the appropriate pilot.

Actuation.

The most obvious differences between the two aircraft are in control actuation. These arise partly because of differences between the aircraft, and partly because of differences in application. The VAAC system uses an electro-hydraulic actuator for tailplane plus pitch reaction controls, electrical actuators for throttle and nozzle angle control,

and front pitch reaction control series actuation, and inputs to existing actuators for flap, roll and yaw. The tailplane is actuated via an hydraulic strut which ensures that the actuator can be disabled. Throttle and nozzle angle are actuated via electrically operated clutches. The remaining controls are actuated via normal auto-stabilizer inputs. Artificial feel for the rear cockpit is provided by (adjustable) mechanical spring and damper units, plus a computer controlled variable stiffness unit.

The ASTRA system uses a total of six electro-hydraulic actuators. Three rotary actuators are used to control aileron, rudder and tailplane angles. Three linear actuators are used to control the positions of the front cockpit centre stick (two axes) and pedal inceptors. All actuators are attached permanently; disengagement is effected by removing hydraulic power to the actuators by "normally off" solenoid valves. The solenoid valves are arranged so that the linear actuators are powered through one valve, but the rotary actuators are powered through both. The linear actuators are used to provide artificial feel to the student test pilot with variable stiffness, linearity, breakout force, backlash, viscous and coulomb friction, stiction and end stops.

GROUND TESTING

The designs of both systems were conditioned by the requirement for a clearly defined interface between the "basic" aircraft and the experimental flight control system, with the safety pilot (or instructor) being in control of the former, and the research pilot (or student) controlling the aircraft only via the latter.

This requirement has allowed adoption of a test philosophy whereby aircraft operation with the system disengaged can be approved without a major test programme. Tests will then be aimed principally at proving that disconnection of the control system can be guaranteed, that the authority of control surface actuation is limited to that of a pilot, that any single system fault will result in disengagement and that the aircraft can be recovered successfully after an automatic disengagement.

Additional tests will, of course, be required to prove that the systems will operate successfully in the aircraft environments, and that operations will not be affected by external interference.

FLIGHT TESTS

The CIT flight test programmes will be divided into several phases. The first is common to both aircraft and is aimed at confirming that the installation has not affected (significantly) the flying qualities of the basic airframe. After this phase the VAAC aircraft will be delivered to RAE for the safety pilot/independent monitor clearance outlined earlier. For the ASTRA aircraft the second CIT phase is aimed at proving the validity of ground tests, whilst the third is aimed at calibrating the system and verifying system performance.

The experimental flight control system will remain switched off during the first phase.

The second phase on the ASTRA aircraft will commence with the system operating, but without the ability to drive the control surfaces. All major events which would normally cause disengagement will be synthesised and (attempted) disengagement confirmed. The system will then be enabled fully, and engagement/disengagement proven, but with reduced operating margins permitted. Margins will then be increased gradually until the system has full authority. During this phase "State" measurement feedback loops will be set to zero gains.

During the final phase on the ASTRA aircraft feedback loop gains will be varied to cover the full operating range. At each setting response measurements will be recorded during step and doublet inputs in order to calibrate the system using parameter identification techniques. Operating margins will be reduced at first in order to prevent structural damage if/(when) system instabilities are experienced. The occurrence of such instabilities will be noted and assessed. If insufficient performance is available as a result of a particular instability, then the system will be modified, either by "notching" the frequency response characteristic of the offending transducer, or by re-siting the transducer in a more favourable position.

CONCLUSIONS

The VAAC programme requires an aircraft for research into VSTOL control concepts and the techniques for their design and assessment. The ASTRA programme aims to create a variable stability aircraft with a wide flight envelope, for training test pilots. These contrasting requirements have led to the adoption of very similar systems to provide the necessary flexibility. CIT is modifying both aircraft, and they are scheduled to fly within a few months of each other.

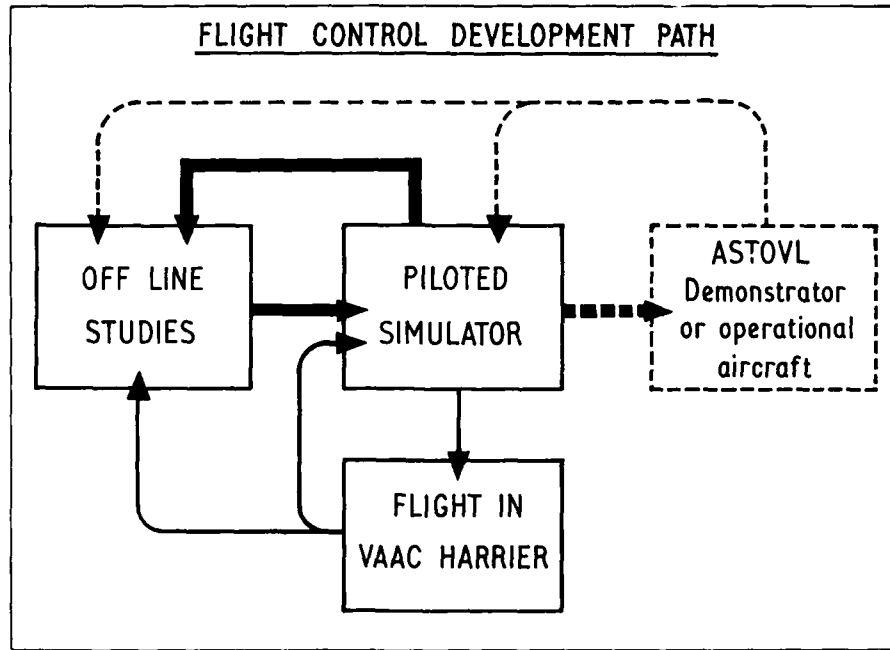

Fig 1

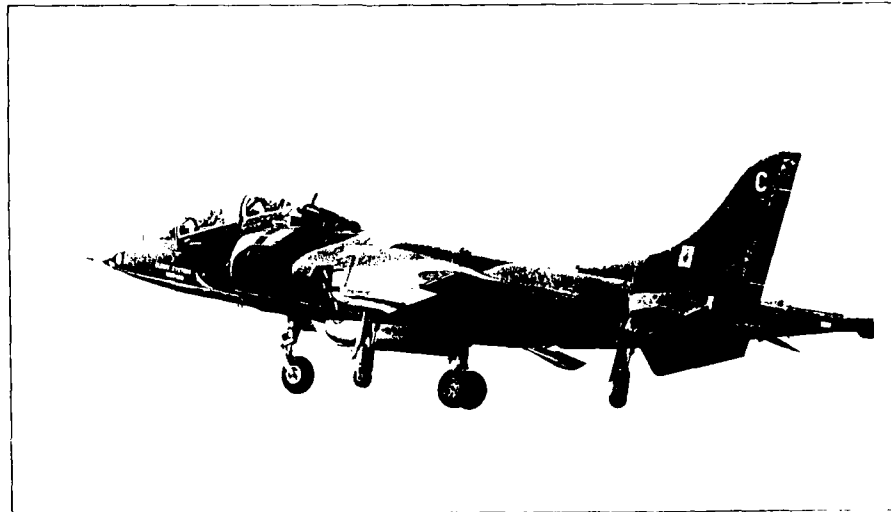

Fig 2

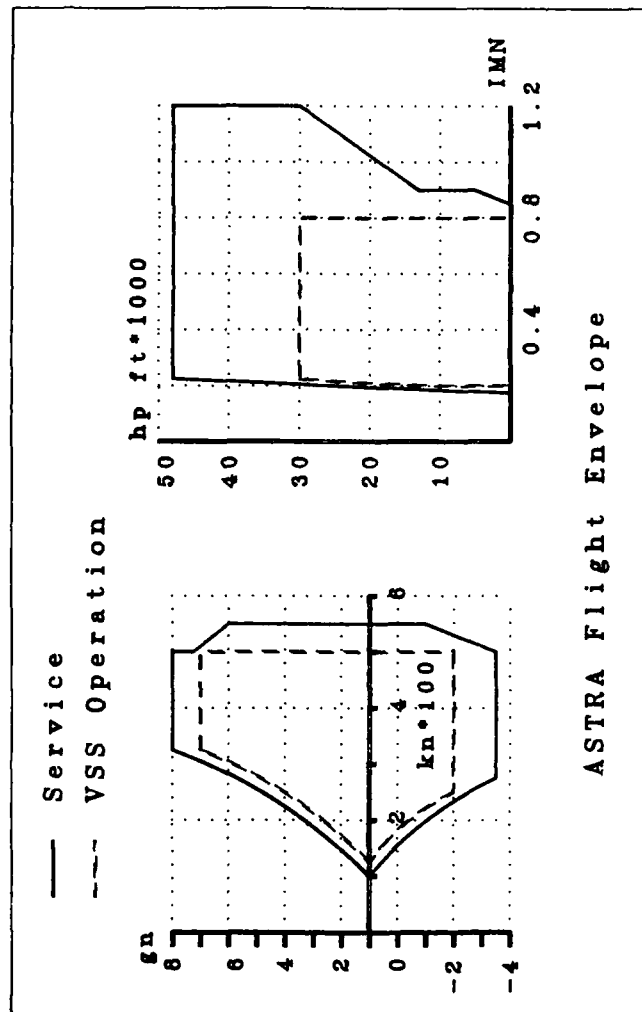

Fig 3

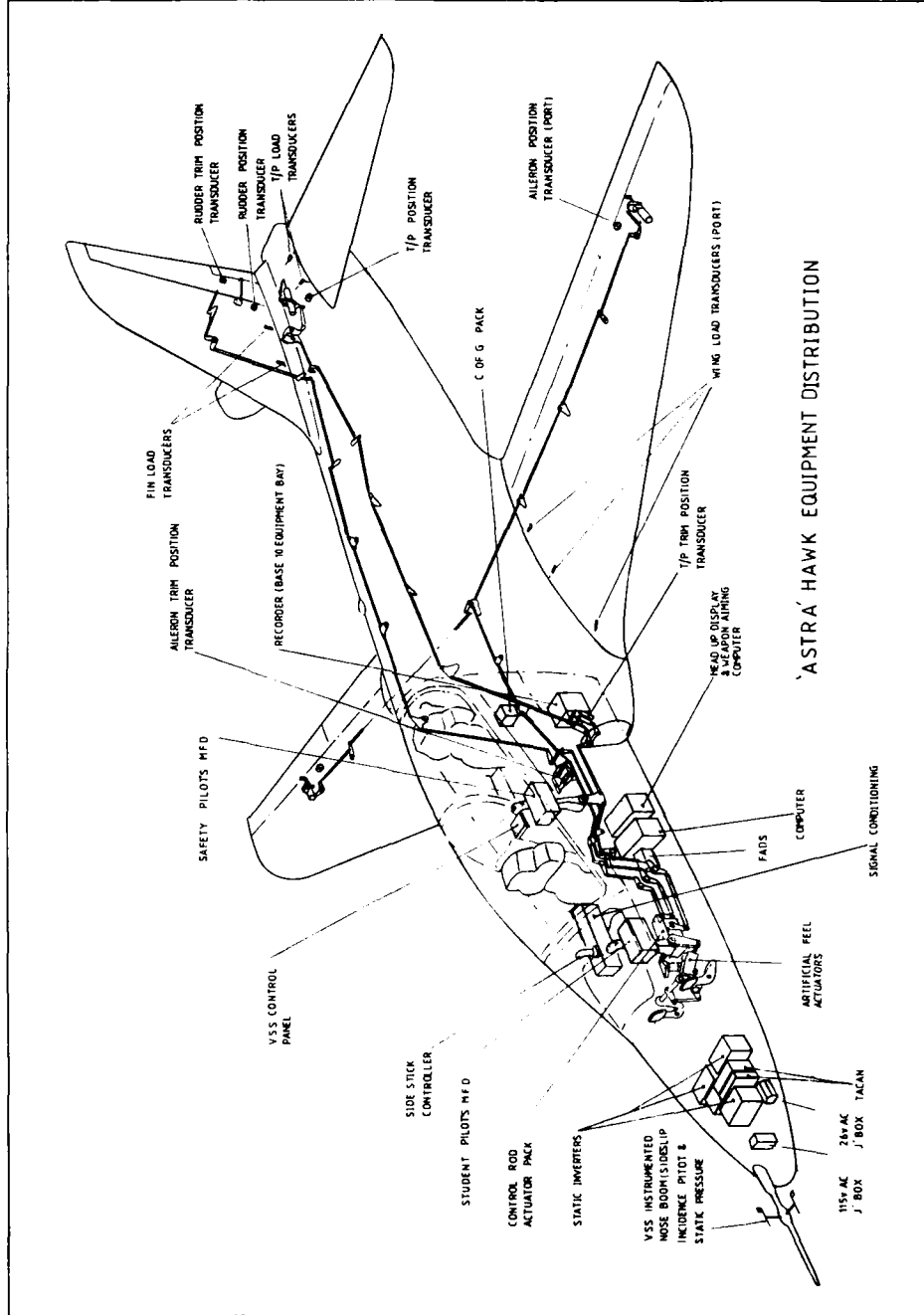

Fig 4

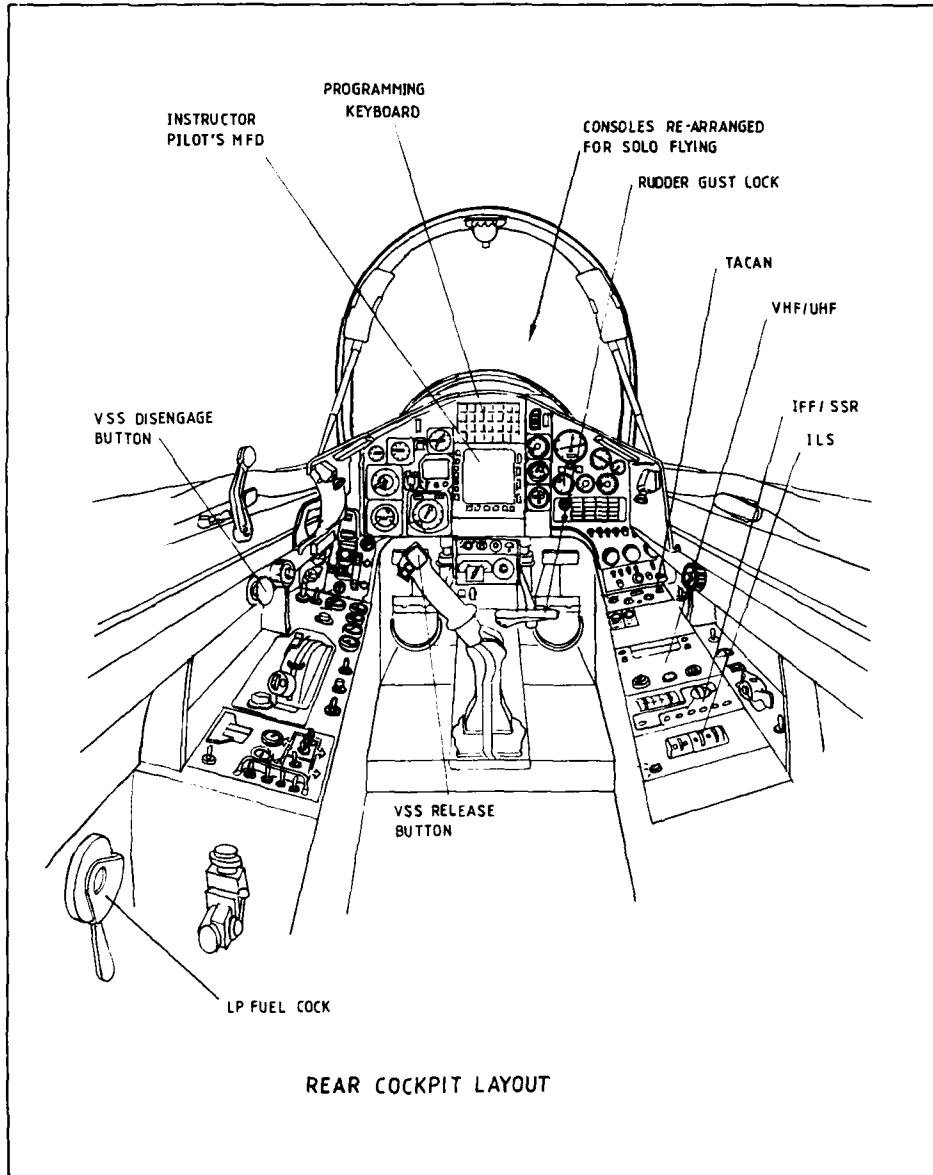
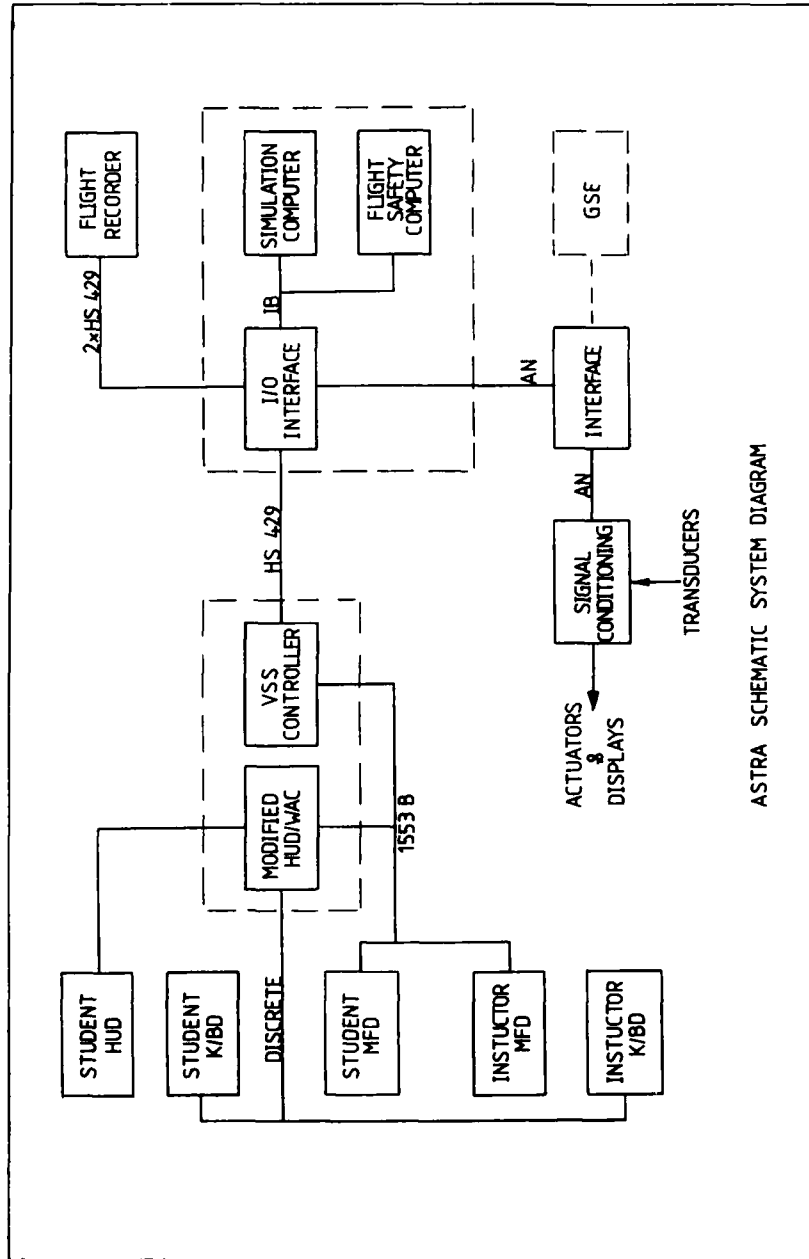
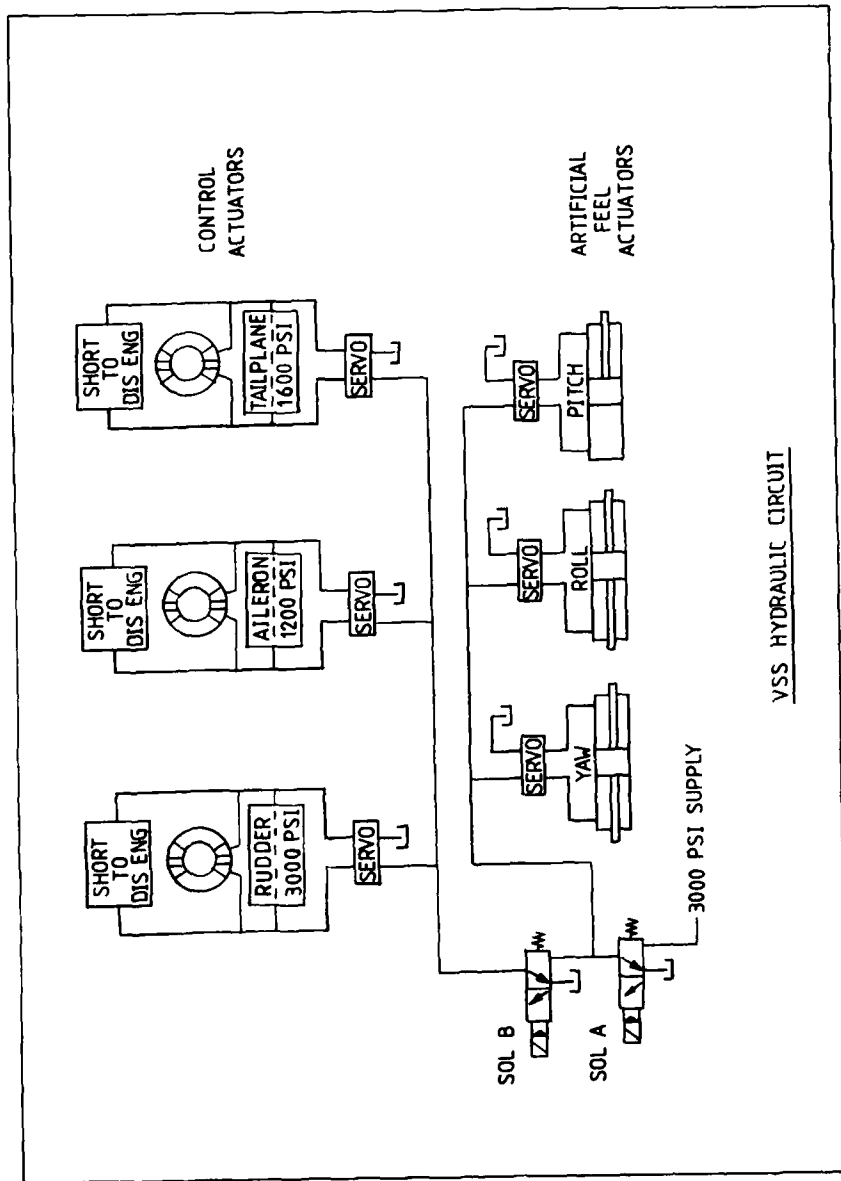

Fig 5



ASTRA SCHEMATIC SYSTEM DIAGRAM

Fig 6



VSS HYDRAULIC CIRCUIT

Fig 7

**AIRBORNE SIMULATION
AT THE
NATIONAL AERONAUTICAL ESTABLISHMENT OF CANADA**

by

J.M.Morgan
Manager
Airborne Simulation Facility
Flight Research Laboratory
National Aeronautical Establishment
Montreal Road
Ottawa, Ontario K1A 0R6
Canada

Introduction

The present Airborne Simulator operated by the Flight Research Laboratory (FRL) of the National Aeronautical Establishment (NAE), is based on a Bell 205A-1 host vehicle (Fig. 1), and is the third generation of such simulators at the laboratory, the previous two being based on Bell 47 models.

This aircraft was acquired by the NAE in 1969, first saw service in the simulation or variable stability role in 1971, and since then has undergone and is still undergoing a process of evolutionary development. This paper will concentrate on the operational aspects of airborne simulation using this aircraft, specifically addressing its limitations and the flight safety implications of operating in a single channel fly-by-wire mode in close proximity to the surface and obstacles. The implications of such operations, encompassing such flight phases as landing and Map of the Earth (NOE) flight on future generations of airborne simulation are also mentioned.

Recent trends in Flight Mechanics research at the FRL have tended to remove emphasis from classical handling qualities experiments to a more system oriented field, and following this the Airborne Simulator has, of late, been used for investigations of the inherent aspects of fly-by-wire systems and as a general research tool in the investigation of various aspects of the 'glass cockpit' and high technology pilot/machine interfacing. In all these areas the inherent flexibility and powerful real-time computational capability of the Airborne Simulator has been used; it has not simply been a surrogate for some generic next generation vehicle.

The Airborne Simulator

Overview

Conversion of the 205A to a variable stability machine required certain fundamental modifications, the installation of a wide range of aircraft and environmental sensors and the provision of considerable computational capability. Some of the modifications to the basic airframe were essential to the conversion of the machine to operation in an electrically signalled mode and have remained unchanged through the whole of its operational life; others, particularly those relating to computational capability, are continually updated as digital processing technology advances and project requirements demand.

While the simulation system has been thoroughly described in Reference 1, one change since that publication is worthy of note. The data recording system has now been replaced by a directly computer compatible streamer tape of 16 bits resolution, file structured and with the facility to record data documentation in the header block of each file. The synchronised voice capability, felt to be of great importance in piloted studies, has not been abandoned, but has been retained by digitising the audio signals and including them in the data format. Figure 2 shows the updated computing system structure.

Cockpit Configuration

The Airborne Simulator is configured for a two man crew, the safety pilot and the evaluator, therefore emphasis has been placed on system interaction from the cockpit. A fixed console between the two pilots' stations (Fig. 3) contains an array of analogue function switches and servo potentiometers, (now largely unused but still with occasional value) a keyboard and display screen, an array of 16 digital function switches for software control and 16 status lights controlled by the digital processors. Additional switches and indicators are frequently added for specific experiments, usually to enhance the realism of an environment for the evaluator. For the same reasons such hardware items as overhead throttle quadrants or left hand operated power levers have been installed at various times.

The evaluation pilot's station is provided with a set of conventional controls (cyclic, collective and pedals), which are themselves a simulation using standard analogue techniques with the pilots applied force as the driver. The control characteristics are adjustable from the cockpit via three arrays of manually set potentiometers, one for each of the three fully simulated channels (cyclic and pedals). Additionally there is provision for the mounting of left or right handed side-arm controllers, (see Fig. 4) the signals from which may be read by the processors either through a conventional analogue/digital converter or a dedicated optical data link.

Operational Requirements

Operating a helicopter in the hover regime at 100 or even 50 feet is, from a piloting point of view, quite different from operating at 10 feet and lower. The error cue gain (by which is meant the perceived change in visual cue for a given aircraft rate or positional error) increases dramatically as the aircraft approaches the surface and this has major system stability implications for man-in-the-loop tasks at very low altitudes. This suggests that to achieve reliable data on handling qualities they must be taken in the operating environment to which they are meant to apply; thus is created a prima facie case for operating the Airborne Simulator throughout the entire flight envelope of the host vehicle, from take-off to landing.

Following this argument another aspect of in-flight simulation pilot risk becomes a distinct factor. There is no doubt that evaluation pilots in the 205 have a definite sense of personal risk almost as great as that which they perceive in conventional aircraft operations. Clearly, the evaluator knows that the safety pilot is ultimately in control of the aircraft and will intervene if necessary, however, especially in high workload and very low level operations, this fact becomes masked by the immediacy of the situation. This introduces an element of psychological restraint which is very difficult to achieve in ground based simulation, no matter how good a simulation subject the evaluator is nor how readily he adapts to and accepts the limitations of his environment.

These considerations have led the FRL to make a practice of operating the Airborne Simulator in the fly-by-wire mode from take-off to landing as a matter of course.

Flight Safety

Philosophy

Operating a single-string fly-by-wire helicopter right down to the earth's surface and in close proximity to potentially damaging obstructions is an operation of inherently high risk. That the FRL has been doing so, safely, for over twenty years is due largely to an operating philosophy and flight practices that minimise the risks involved while intruding as little as possible on simulator performance. These are based on a minimum level of automatic protection against system failure and the presence in, or at least parallel to, the main control loops, of a safety pilot. It is the anticipatory nature of the human pilot, in conjunction with the inherently slow response of a teetering rotor control system, which is largely responsible for the accident free record of FRL in fly-by-wire operations.

Hardware Protection

A core element of the fly-by-wire system is the so called 'Safety System', a set of sub-system health monitors which must simultaneously indicate a normal state for the fly-by-wire system to be active. These include hydraulic system pressure switches at each actuator (not purely system line pressure), electrical power supply monitors, an analogue computer mode monitor, a main rotor flapping angle monitor and two levels of digital error monitoring. The latter are not truly automatic systems, since they rely on the software to detect specific types of error and subsequently to flag the safety system. If an error condition occurs with the fly-by-wire system engaged, control is immediately transferred to the safety pilot. Significantly, neither actuator rate, nor actuator position is an input to this system, that is, the actuators are not in any way rate or authority limited by the Safety System.

Software Protection

Although the level of software protection is left up to each individual experimenter, the standard techniques of overflow protection are universally used, and frequently, in those cases where it is possible, a consistency check on aircraft sensors is carried out. This latter form of check is becoming of greater significance as the move to active control technology (with the implied very high loop gains) proceeds in conjunction with very low altitude operation. Under these circumstances the aircraft is frequently at the risk of becoming uncontrollable in the event of a feedback sensor failure, or even, as has occurred, when an unusually aggressive evaluation pilot exceeds the sensing limit for one of the critical parameters.

The Safety Pilot

The safety pilot in the Airborne Simulator has several responsibilities during experimental flying. He is always the aircraft captain, he controls the fly-by-wire system, and performs other ancillary functions according to the requirements of a specific project. However, once the project system is engaged his prime function is to monitor its behaviour and the aircraft flight path and to intervene as necessary to prevent excessive risk to the aircraft. This is far from a trivial task and calls for the frequent use of fine judgement as to how far he may permit a condition to deteriorate before intervening. It is a rigidly held practice that he always flies hands-on since it is generally possible for an experienced safety pilot to detect whether a specific aircraft or control motion is due to an evaluation pilot input, a control system input or a system malfunction. If a malfunction is suspected he may, using a cyclic lever mounted 'instinctive release', disengage the fly-by-wire system thus preventing any further electrically signalled actuator motions; alternatively he may over-ride the computer generated actuator commands while determining the extent of the malfunction and assessing the need to disengage. That safety pilot experience is of the uttermost importance cannot be too strongly emphasised. To put this in perspective, when the author first undertook the role, he let some two years go by before he felt competent to fly that position in hover related experiments.

Experimental Philosophy

Project Management

The FRL operates its projects under a special version of the 'Project Engineer' philosophy. At FRL the Project Engineer takes on the complete end to end series of tasks including experimental design, algorithm development, computer coding and debugging and the full airborne phase of test and development. The advantage in the 'total responsibility' approach is a great saving in time from experimental conception to execution. This is especially true at the debugging stage, since the full range of knowledge necessary to understand the system completely is embodied in one person. This same procedure is considered to be another contributing factor in the safe operation of the 205 since errors or misunderstandings which can occur in communications between groups of varying disciplines are eliminated by definition.

Software Development

Writing real-time software for airborne vehicle control is usually a very time consuming and labour intensive operation. The Space Shuttle program offers a typical example of this, wherein the integrity of the software is vital to the safe operation of the vehicle. In that case a large bureaucracy developed with the specific function of overseeing and maintaining a quality assurance on such software with the result that, quite rightly, the simplest change can take over six months to implement. In the research environment of the FRL and under the project engineer system mentioned above complete changes of software functions between successive experiments can be realised in a very short period of time, often just a matter of hours.

All software for real time operations is written in assembler language using integer arithmetic as a general rule but with the option of using hardware supported floating point if necessary. Again as an evolutionary process, it is usual that the software suite required for a specific experiment is constructed by the modification of that used in a previous session, changing only those portions which need alteration and deleting items no longer required. This technique has a disadvantage in that it does not lend itself easily to formal documentation, and relies heavily on the personal and continuing involvement of the same project engineers in a series of related projects. The advantage is that much of the program for a new experiment is 'old code', well understood and fully debugged.

Each new software set is debugged logically and mathematically before flight by standard techniques, including a stage in which the aircraft and its systems are fully active and the fly-by-wire system is engaged. This is then followed by an airborne development phase in which loop gains are fine tuned empirically to achieve optimum system performance in the presence of the real world lags, vibrations and non-linearities of the host vehicle.

An effort is under way to modularise large sections of code, especially since many of the processes do not change from experiment to experiment, and would lend themselves well to this approach. Some fully debugged modules already exist and are regularly incorporated into active project systems and it is anticipated that others will be added in the coming year.

Loop Closure Techniques

The 205 host vehicle displays significant control response lags, main rotor/transmission mounting vibrations, control input cross couplings and non-linear characteristics. If these effects are not treated in the loop closure process, both maximum achievable gain and closed loop response characteristics are limited to an extent which would render the Airborne Simulator quite unuseable in its required role. The treatments used are primitive but effective, and are listed below:

- a) Control response lags are effectively removed from the feed-back loops by the use of a mixed response signal comprising the aircraft response at low frequency and the output from a simple, lag free, linear model of the 205 at high frequency (above 1.5 Hz).
- b) Significant airframe vibration modes are treated by a combination of hardware signal processing filters combining both second order low-pass and specific frequency notches.
- c) Cross coupling effects are alleviated by the use of control input feed-forward techniques.
- d) Non-linearities are treated by scheduling loop gains as functions of both forward speed and, occasionally, engine torque.

A typical loop closure is shown in Figure 5.

The Next Generation

Compared to most modern helicopters, the 205 has low control power and large control response lags and can therefore address only a small part of the flight dynamics of such aircraft directly. This observation has led the FRL into an active search for a replacement for the present host vehicle. While several production machines already exist which could potentially replace the 205, the implications of such an acquisition go far beyond the initial cost and the demands that would be made on the

Laboratory's resources to convert it into an airborne simulator. The discussions above show a system that has been successfully operated with the minimum of automatic protection against failure and with a very heavy reliance on the intervention of a human pilot to prevent a system malfunction producing catastrophic results. It is doubtful if this philosophy would be sufficient if a machine of much higher control power and much shorter lags were to replace the 205.

Since all machines actively examined as a 205 replacement have dual hydraulic systems, and since the cost decline and miniaturisation of digital equipment continues apace, there would probably not be a great difficulty in duplicating the hardware and signal paths in a new simulator, but the impact on the operating practices at the FRL might be very large indeed. If duplication with mutual comparison were adopted as the prime means of ensuring an adequate level of safety in fly-by-wire operations, then it is impossible to maintain the single end-to-end project engineer concept as it is presently practiced. A large measure of system integrity could be maintained by, say, permitting the same person to program both signal paths using different languages to code the processors, but that would still leave the aircraft at risk due to mathematical or logical errors on the part of the system designer. If the Laboratory is to avoid the complexity of having every system fully worked by separate engineers then other methods of maintaining safety standards will have to be considered. Temporary rate or authority limitation during software development is a candidate procedure which may serve this purpose.

Project Involvement

While the following paragraphs give a brief description of currently active research projects which use the 205 as a primary tool, a somewhat fuller description may be found in Reference 3.

Advanced Control Systems

The FRL has, for the past several years, been involved in several areas of research relating to the development of advanced control systems for helicopter use. Command control systems based on angular acceleration, rate or attitude have been used in various experiments (References 4 and 5), together with a variety of command augmentation systems. This work is now driven largely by an interest in updating MIL-H-8501, the US military helicopter handling qualities specification, and consequently in the generation of a data base on the characteristics of active control systems in helicopters. While much of the work in this area is being conducted in large and powerful ground-based simulators, where it is possible to evaluate very large parametric matrices in a relatively short time, the FRL Airborne Simulator is playing a significant, perhaps vital, role in the process.

The art of simulating a helicopter at low speeds and in the hover with sufficient fidelity to produce data against which specifications can be written is still an uncertain one. The difficulties inherent in trying to reproduce adequately the extremely fine grained visual and motion environment in which the helicopter operates is daunting; in an airborne vehicle, however, such cues are real world. The FRL is participating in the program, therefore, by both complementing and validating data from such ground-based simulations. Some of the results recently obtained suggest that data acquired in ground-based simulation are perhaps more conservative than had previously been thought. This has been highlighted in a series of experiments being conducted jointly by the U.S. Army Research Laboratory and NAE.

Data from recent piloted flight experiments in comparison with similar data taken at the NASA Ames Research Centre in the Vertical Motion Simulator (VMS) are presented in Figures 6 and 7. Both of these plots are for precision hover tasks in good visual flight conditions and both show pilot Cooper-Harper ratings as a function of control system bandwidth. Figure 6 represents data obtained using an Attitude Command/Attitude Hold Control system, while the data in Figure 7 were obtained when a Rate Command/Attitude Hold system was being evaluated. Both plots indicate that the evaluation pilots were more tolerant of low response bandwidth in the aircraft than they were in the groundbased simulation. Additionally, the spread of ratings as evidenced by the standard deviation boundaries suggests a closer agreement between evaluators in the air than in VMS.

For this experiment, pitch and roll control systems in the Airborne Simulator were implemented in exactly the same way that they were in the VMS while yaw control was via a rudimentary rate command/heading hold system. Collective control was either a simple direct drive in the case of the conventional collective lever or an integral/proportional system used with a force sensing fully integrated side-arm controller. Pitch and roll response bandwidths were varied by altering (referring to Figure 8) the values of K , K_1 and G_2 . Switching N between 1.0 and 0.0 with $K_2 = 1.0$ changed the response type from rate to attitude while the combination of $N = 0.0$ and $K_2 = 0.0$ produced a rate damped system. The bandwidths achieved in the 205 and shown in Table 1, were measured by the Fourier analysis of the aircraft's response to a computer generated frequency sweep, taking the 45 degree phase margin point as determining bandwidth.

Although the full analysis is not yet complete and, therefore, no further comparative data are available, additional data taken during airborne simulation are presented in Figures 9 to 12. A set of four representative tasks (precision hover, precision landing, accelerate/stop and sidestep) were flown by five pilots using all

control systems in a random sequence. For each control system the pilot was allowed to optimize the stick sensitivity to his own taste before commencing an evaluation based on three executions of the task sequence. The experiment was repeated using an integrated side-arm controller in place of the conventional controls. In the figures, the (a) plot is of data taken using conventional controls, while (b) refers to the use of the side-arm controller. In all cases the tasks were flown in good VMC and in atmospheric turbulence ranging from calm to moderate (surface wind 25 gusting to 40 knots).

A somewhat surprising result is to be seen in the consistently low HQR ratings given to the rate damped systems, suggesting that pilots do not need, or are even hindered by long term stability loops in this flight regime. It is possible that this result would not obtain in poor visual conditions and this will be investigated in the next series of experiments. A full description of this work will be published jointly by FRL and Systems Technology Inc. of Hawthorne, California who are involved in the project under contract to the U.S. Army.

Display Technology

The powerful and flexible on-board computational capability of the Airborne Simulator has made it an ideal tool for the development of electronic display systems. The prime task in this area is the cooperative evaluation with Litton Systems of Canada of a dot-matrix LED display in both the ADI and HSI modes (See Figure 13). The capability to program such a display at project level has also permitted some work to be conducted on the inherent characteristics of such displays, addressing such factors as update and refresh rates, lags, hysteresis and digital resolution. The initial study in this area (the findings from which are generally applicable to electronic displays of primary attitude data and are not restricted to dot matrix formats) is reported in Reference 13.

The results suggest that at least in the transport helicopter IFR regime, pilots will tolerate much lower quality displays of primary attitude than might be expected. Refresh rate, update rates, hysteresis and digital resolution degradations well beyond those easily achieved with current technology were required to reduce significantly the pilot perceived handling qualities of even a primitive machine.

Integrated Side-Arm Controllers

This project preceded but is very closely related to the FRL efforts in advanced control systems since operation of a typical helicopter by means of a fully integrated, or even partially integrated, manipulator postulates some form of stability augmentation. A series of reports, References 4 and 6, have been made on this project. Additionally the laboratory, still using the 205 as a system development vehicle, is assisting a Canadian aerospace company in the development of a possible commercial unit quite different from those generally available. This device (Fig. 14) is a fully integrated four function manipulator consisting of a hand grip mounted on a short stalk protruding from an armrest-mounted main casing. The hand grip rotates about three orthogonal axes to give three degrees of freedom, while the stalk has a linear vertical motion to provide the fourth. The controller has the potential to be expanded to a six degrees of freedom device by the provision of longitudinal and lateral linear motions. Details of this work can be found in References 7 to 9.

Helicopter IFR Handling Qualities Requirements

An additional area of interest, this time a joint interest with the United States Federal Aviation Administration, is the determination of the handling qualities requirements for expanding the helicopter IFR envelope sufficiently to permit Category III approaches to a heliport. This is an important area of research at FRL and dovetails well with two existing areas of interest at the Laboratory, advanced controls and display technology. Experiments so far have considered flight to a decision height of 50 feet and a speed of 22 KIAS. The results suggest that some form of control system augmentation is required to permit the implied descending decelerating approach and that equally necessary is the provision of a flight director tailored to the specific task. Three reports, References 10 to 12 present the findings of the initial experiments, while data has been taken, but not yet published, for a further study.

Voice Recognition

The 205 is currently involved in generating a high quality data base for research into cockpit voice inter-action in the helicopter environment. The work is being conducted using various microphone configurations and combinations in conjunction with a specially installed high quality audio tape recorder. The data from this project will be made available to NATO RSG-10 who have been cooperating with the FRL in this field. The laboratory also plans to examine two-way voice communication hardware in the 205 in the near future.

Concluding Remarks

This paper has attempted to give an overall description of the Airborne Simulation program at the FRL in terms of the operation of the Simulator, its project involvement and the extent of active research being carried out using the facility. It has attempted also to provide a feel for the dynamics of FRL work in this field. The essentially informal atmosphere at the Laboratory and the freedom from excessive administrative procedures enjoyed by the research staff is probably a function of size (17 scientific staff) and could be difficult to establish in a larger organization.

Acknowledgement

It is appropriate in this paper to acknowledge the work of Mr. Keith Davidson, who, in the dual function of Instrumentation Technician and primary Safety Pilot, has made an immense contribution to the entire Airborne Simulation program at FRL over the last 15 years.

The Advanced Control Systems research is partially funded by the Canadian Department of National Defence, Chief of Research and Development Division.

References

1. Sattler, D.E. The National Aeronautical Establishment Airborne Simulation Facility. Paper presented at the 31st Annual CASI General Meeting, Ottawa, Canada, 1984.
2. Heffley, R.K.A. Compilation and Analysis of Helicopter Handling Qualities Data, Volume 1: Data Compilation NASA CR 3144 August 1979.
3. Sinclair, S.R.M. Kereliuk, S. Morgan, M. An In-flight Simulation Program at the NAE Flight Research Laboratory. Paper presented at the CASI Annual Meeting, Montreal, Canada, May 1985.
4. Sinclair, S.R.M. Morgan, M. An Investigation of Multi Axis Isometric Side-Arm Controllers in a Variable Stability Helicopter. NAE LR-606, NRC No. L9629, August 1981.
5. Morgan, M. Some Piloting Experience with Multi Function Side-Arm Controllers in a Helicopter. Proceedings of the joint NASA/AHS Helicopter Handling Qualities Specialists Meeting NASA CP 2219, April 1982.
6. Morgan, M. A Piloted Experiment in the Use of Multi-Function Side-Arm Controllers in a Variable Stability Helicopter. Paper presented at the 9th European Rotorcraft Forum, Stresa, Italy, September 1983.
7. Lippay, A.L. et al Morgan, M. Helicopter Flight Control with One Hand. Paper presented at the CASI Annual Meeting, Montreal, Canada, May 1985.
8. Morgan, M. Lippay, A.L. et al Flight Test of a Displacement Side-Arm Controller. Paper presented at the Annual Conference on Manual Control, June 1985.
9. Morgan, M. A Comparative Study of an Articulated Integrated Side-Arm Controller in a Variable Stability Helicopter. Paper presented to the 41st Annual Forum of the AHS, Fort Worth, Texas, May 1985.
10. Sinclair, S.R.M. Kereliuk, S. Evaluations of Helicopter Instrument-Flight Handling Qualities. NAE LR-608, January 1982.
11. Sinclair, S.R.M. Kereliuk, S. Evaluation of the Effects of Lateral and Longitudinal Aperiodic Modes on Helicopter Instrument Flight Handling Qualities. NAE AN 15, July 1983.
12. Kereliuk, S. Morgan, M. A Preliminary Investigation of Handling Qualities Requirements for Helicopter Instrument Flight During Decelerating Approach Manoeuvres and Overshoot. NAE AN 26, NRC No. 24173, February 1985.
13. Sattler, D.E. Flight Evaluation of a Solid State Dot-Matrix Display as the Primary Instrument for Transport Helicopter IFR Paper presented at the AIAA Atmospheric Flight Mechanics Conference, Snowmass, Colorado, August 1985.

Symbols Used in the Figures

ω	Filter break point rad/sec
e_q	Pitch rate error
k	Generic gain
\dot{P}_{ca}	Model control power derivative
\dot{M}_{ca}	Model pitch rate damping derivative
δ_{ca}	Control input to longitudinal model
q_{com}	Commanded pitch rate
\dot{q}_m	Model angular acceleration in pitch
q_m	Model pitch rate
q	Aircraft pitch rate
q'_p	Low passed aircraft pitch rate
q_{mix}	Mixed or Blended pitch rate
V	True airspeed

Table 1 Measured Response Bandwidth (RAD/SEC)

CASE #	BANDWIDTH		
	ROLL	PITCH	
0	1.5	1.6	ACAH
1	2.8	2.7	
2	3.1	2.74	
4	1.3	0.75	RCAH
8	1.9	2.05	
5	2.1	1.9	
6	2.8	2.0	
12	1.7	2.2	RATE DAMPED
10	3.0	1.5	
11	3.5	1.8	

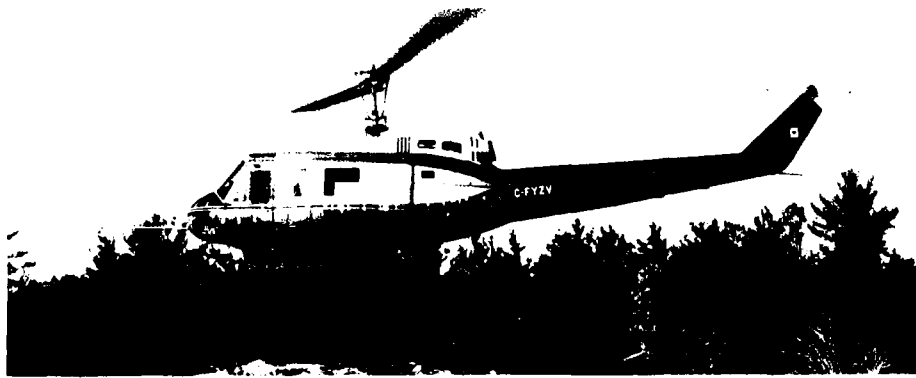

Fig. 1 Bell 205A1G C-FYZV airborne simulator

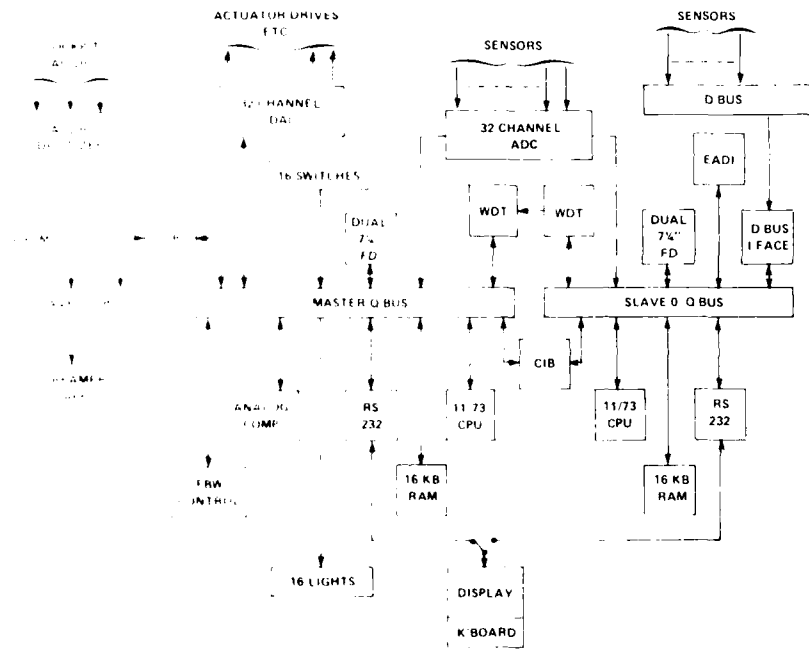

Fig. 2 Digital computing system structure

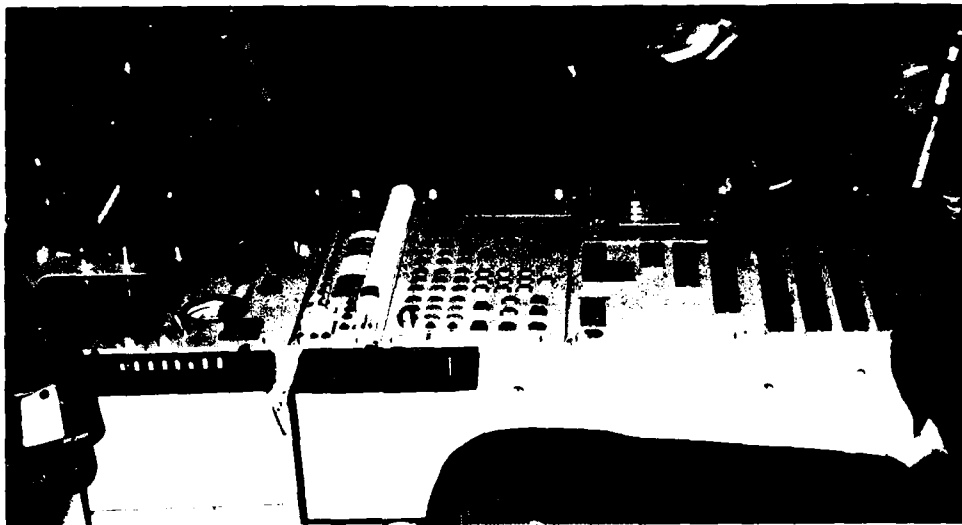

Fig.3 Centre console



Fig.4 Side-arm controller installation

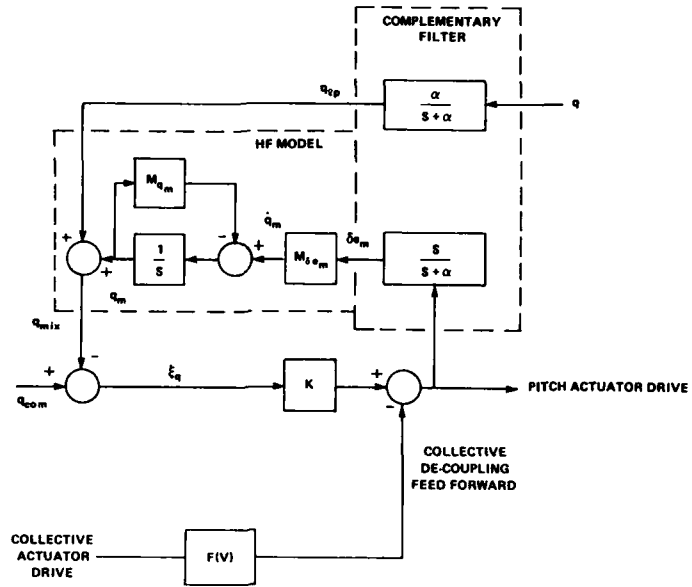

Fig.5 Typical loop closure

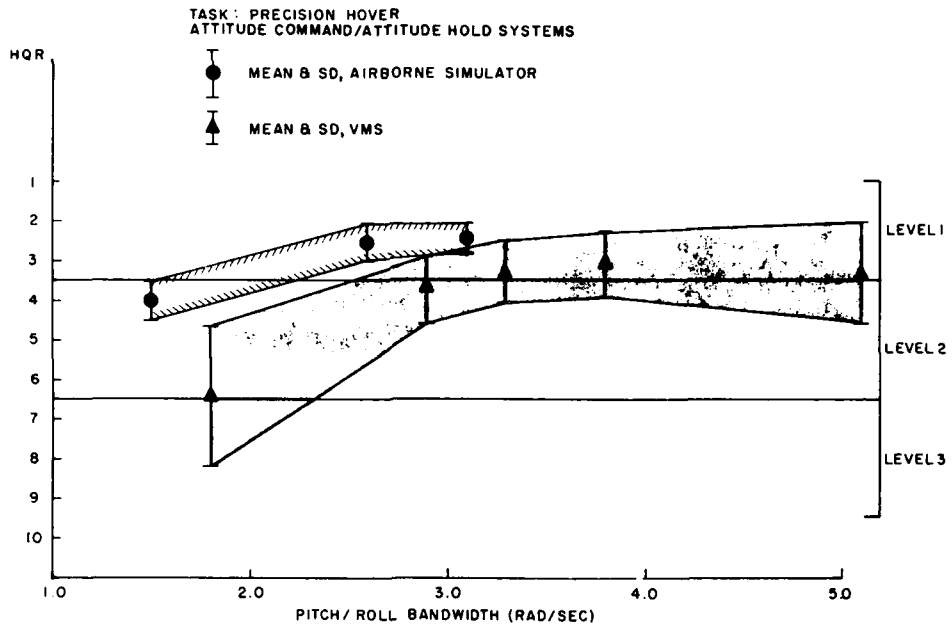

Fig.6 Data from attitude command systems

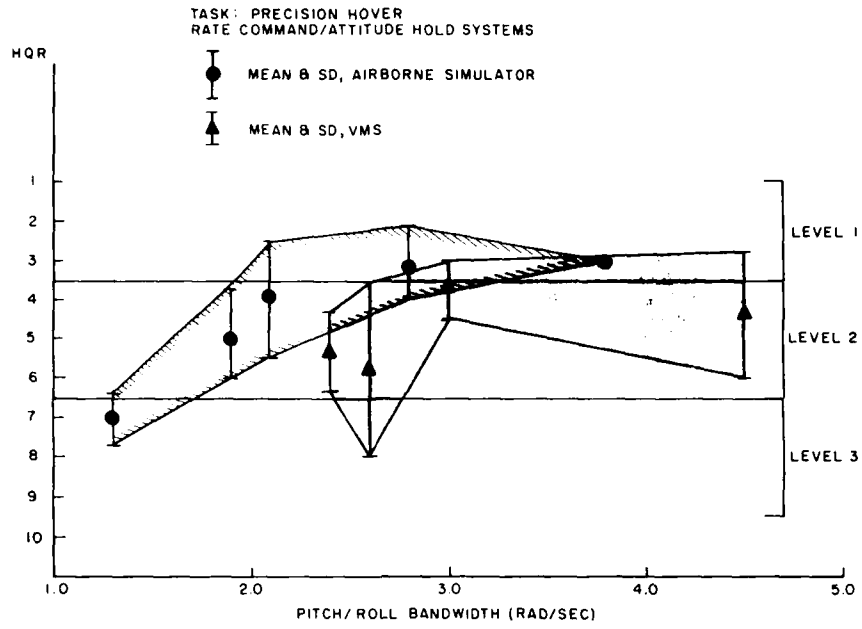

Fig.7 Data from rate command systems

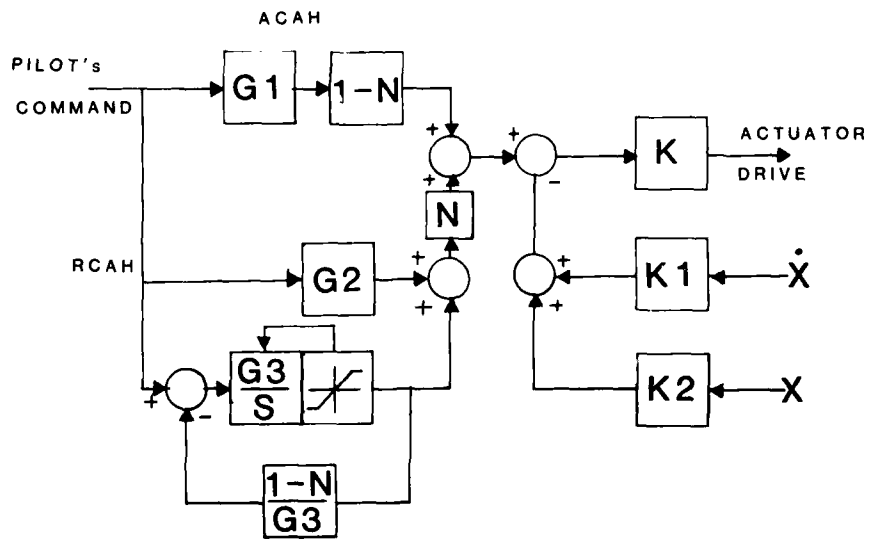
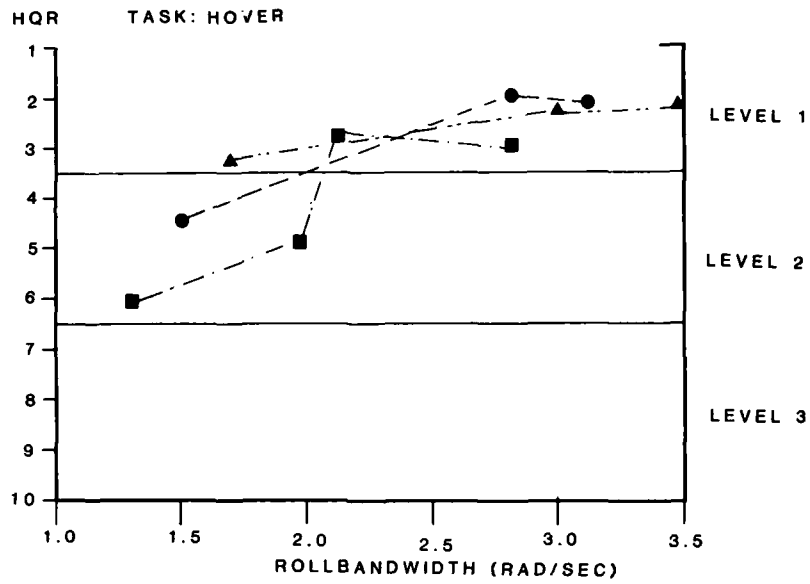

Fig.8 Pitch/roll control systems

CONVENTIONAL CONTROLS



INTEGRATED FOUR-FUNCTION SAC

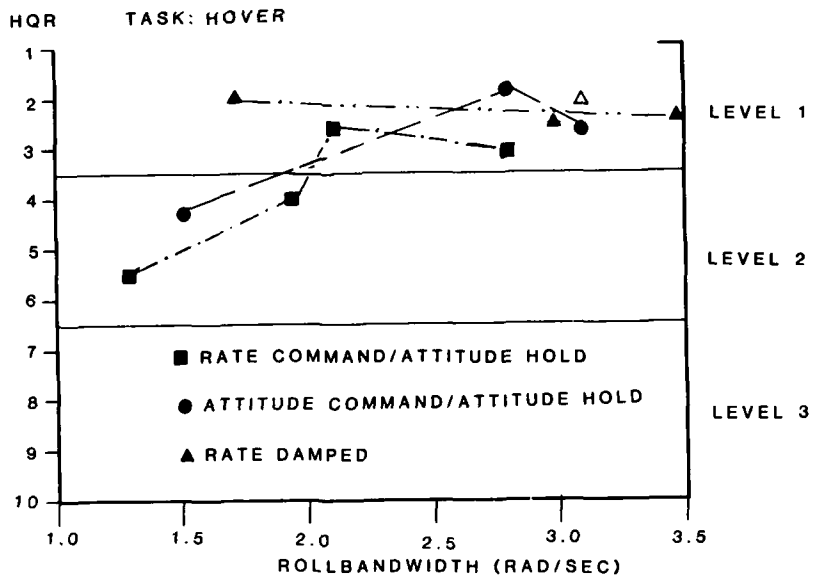
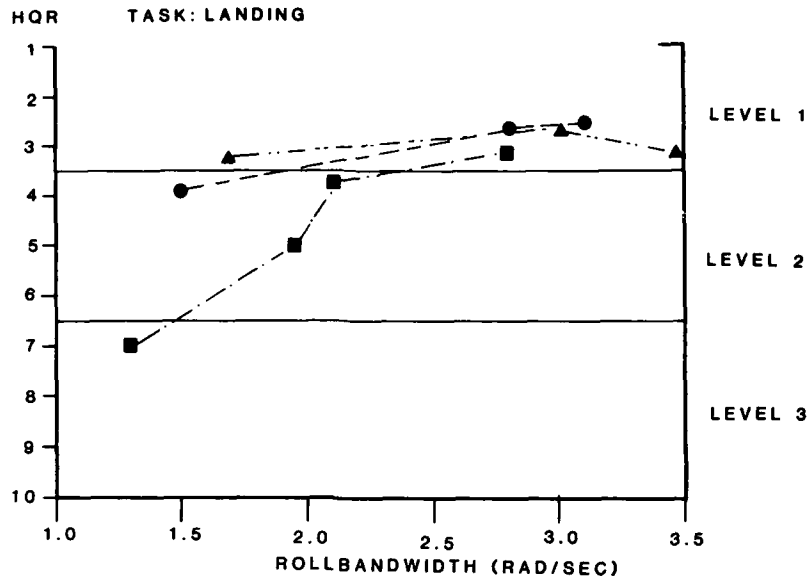

Fig.9 Flight data (hover)

CONVENTIONAL CONTROLS



(a)

INTEGRATED FOUR-FUNCTION SAC

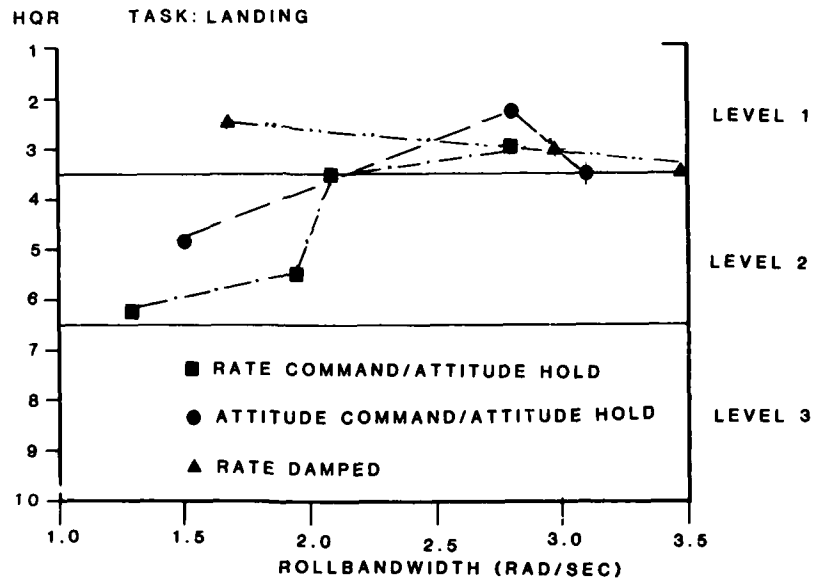

(b)

Fig.10 Flight data (landing)

CONVENTIONAL CONTROLS

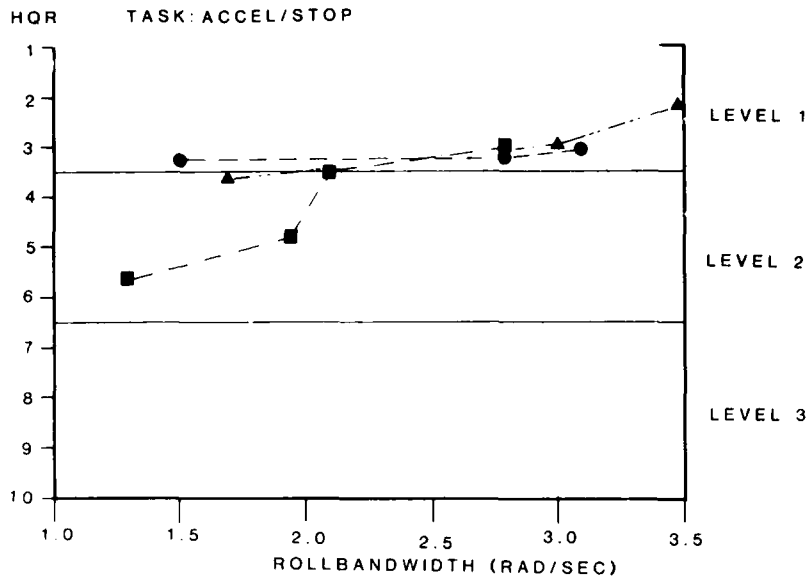

(a)

INTEGRATED FOUR-FUNCTION SAC

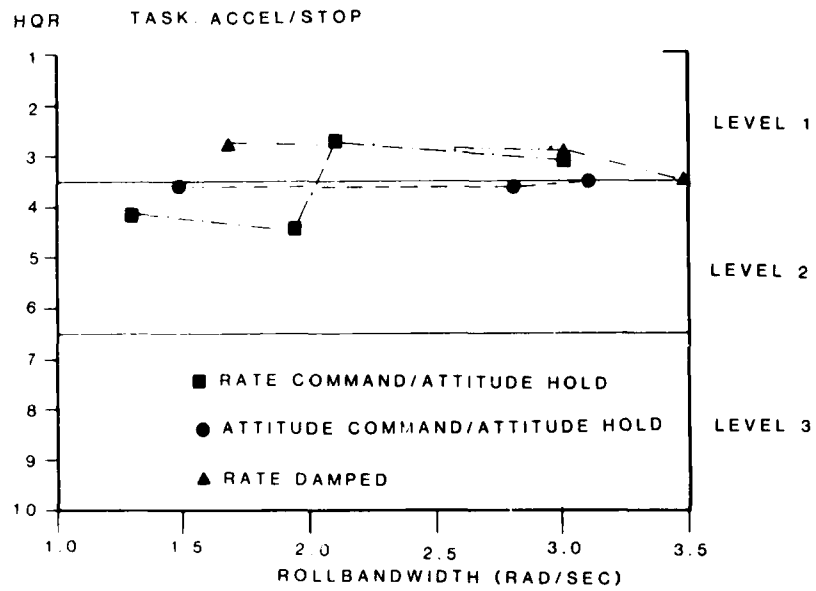

(b)

Fig 11 Flight data (accel stop)

CONVENTIONAL CONTROLS

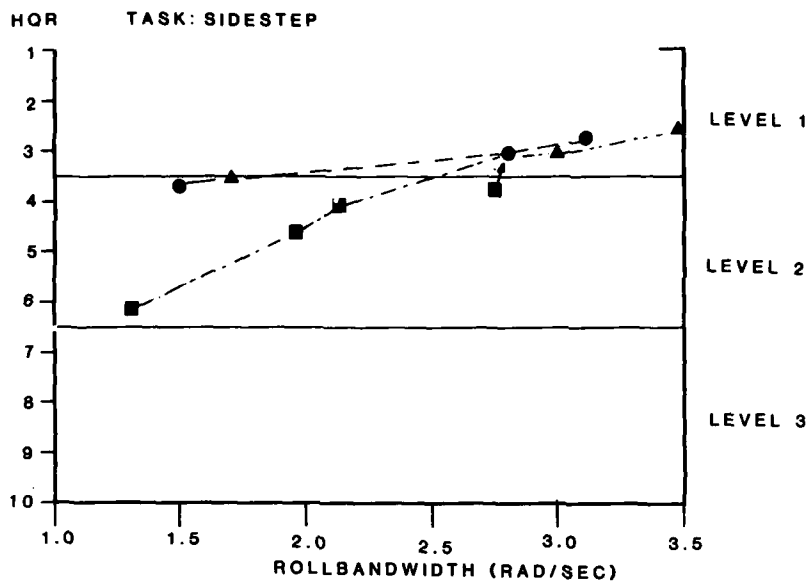

(a)

INTEGRATED FOUR-FUNCTION SAC

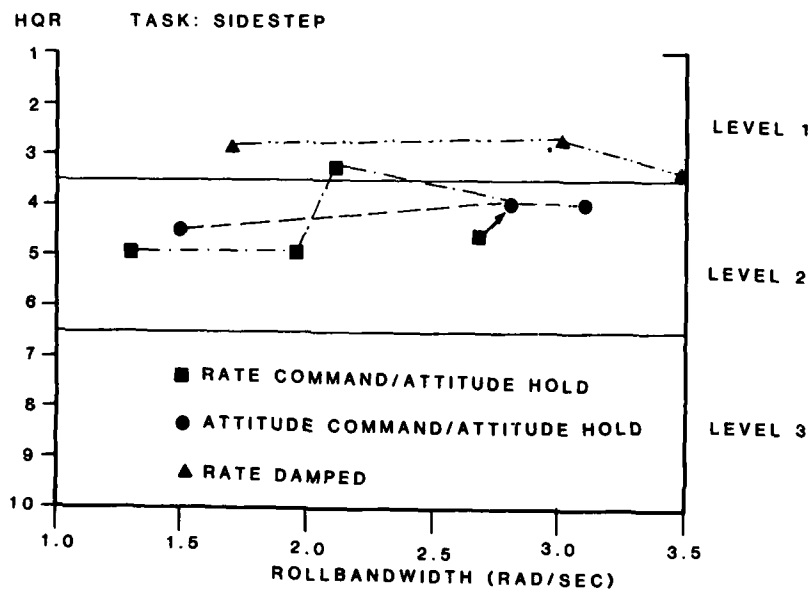

(b)

Fig.12 Flight data (sidestep)

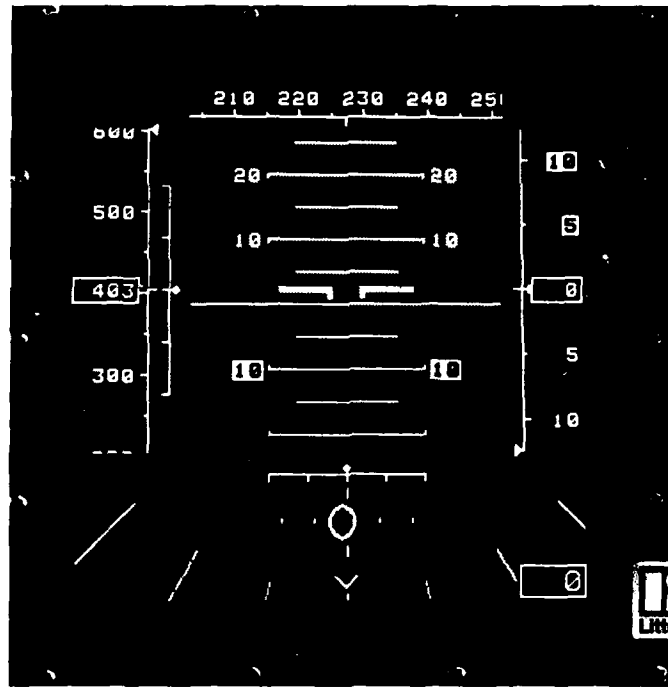

Fig.13 LED dot matrix display

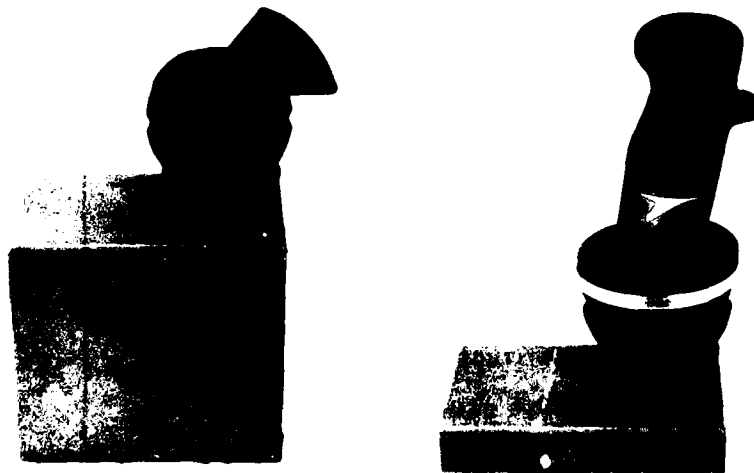

Fig.14 Articulated four function controller

COLLECTED FLIGHT AND SIMULATION COMPARISONS AND CONSIDERATIONS

Irving L. Ashkenas
 Vice President
 Systems Technology, Inc.
 13766 S. Hawthorne Boulevard
 Hawthorne, CA 90250 U.S.A.

ABSTRACT

Government-sponsored research at Systems Technology, Inc. dealing with simulation fidelity and utility is reviewed, starting with some generic effects of motion and vision system characteristics and of computational artifacts. Diagnostic methods and tools useful in discovering and delineating significant qualitative and quantitative differences between simulation and flight are then exposed and illustrated. Finally, examples of both fixed and moving simulation successes and shortcomings are reviewed and examined as to root causes of either. The research-simulator equipment involved in the above comparisons ranges from modern large-scale motion systems and computer-generated imagery to fixed-base with simple CRT-generated displays.

I. INTRODUCTION

A. GENERAL BACKGROUND

The general subject of this paper is the specific experiences that our group at STI has had relative to the topic of simulator fidelity. These experiences cover a number of years with emphasis on the more recent; and reflect in part, our simulation background, as incompletely (omits in-flight and ride qualities simulations) exhibited in Table 1. Note that this background spans the range from the most modern and sophisticated to simpler and more rudimentary, but does not include our own modest fixed-base, facilities. In many cases we have found convincing reality and practical fidelity in the very simplest as well as the most sophisticated.

B. SOME NOTIONS OF FIDELITY

Consider first some useful ideas on simulator fidelity (see Ref. 1). The AGARD Working Group 10 (Ref. 2) presents a discussion of fidelity which distinguishes two main "types": objective and perceptual fidelity.

Objective fidelity, or perhaps more precisely, engineering fidelity (Ref. 3), is the degree to which the simulator reproduces measurable aircraft states or conditions. In terms of motion, perfect engineering fidelity would correspond to a one-to-one duplication of inertial-based displacements, velocities, and accelerations in each axis of freedom.

Perceptual fidelity is the degree to which subjects perceive the simulator to duplicate aircraft states or conditions. This type of fidelity is pilot-centered, includes both psychological and physiological effects, and can be (incompletely) described in terms of engineering fidelity by e.g., characterizing the human vestibular system in terms of effective washouts, lags, and thresholds, as in a mechanical motion base platform.

Another aspect of fidelity is that of induced pilot control strategy and technique. A recently convened NASA Advisory Subcommittee (Ref. 4) defines simulator fidelity as the adequacy of perceptual effects and their consequent pilot response behavior (i.e., control strategy and technique) induced by the simulator.

The use of the term "error fidelity" has been suggested to formalize the idea of evaluating the fidelity of a simulator for a specific task in terms of the similarity between the errors occurring in the simulator and those occurring in the aircraft.

These concepts and ideas free us from the notion that perfect fidelity is a one-to-one correspondence between simulator systems and the actual aircraft -- a practical impossibility anyway. Rather, perfect fidelity is characterized by the simulator pilot behaving in a manner appropriate to the aircraft situation. This implies that:

- The task variables have been defined, and include the specific purposes, assignments, and commands comprising the mission strategy, the likely guidance media, the vehicle to be used, and the likely disturbances and counteractions to be expected throughout the mission profile. Task variables comprise all the system inputs and those vehicular elements external to the pilot which enter directly and explicitly into the pilot's assignment.
- The feedback (and feedforward) cues essential to the task can be (a) employed by the pilot and (b) discovered by the analyst. These cues are called "essential feedbacks (Ref. 5)." The feedback cues actually selected by the pilot will correspond to the states which are both necessary and sufficient to satisfy the guidance and control needs and certain pilot-centered requirements.

C. CONTENT OF PAPER

Keeping the above concepts and definitions in mind we will first consider in the next article the contributions of various subsystems to simulator fidelity. In effect this is a review of what is important and what can go wrong with various subsystems: motion, visual, computer complex.

Next we take up the subject of diagnostic tools -- how do we find out what is wrong with the simulation in the context of the task under investigation. In the last article we offer examples of the correspondence or lack thereof between simulator and real world results. These last two articles also contain examples of simulation fidelity problems which augment the results and discussion in the first article.

II. SUBSYSTEM CONTRIBUTIONS TO FIDELITY

A. MOTION EFFECTS

In establishing fidelity requirements for the simulation of cockpit motion, consideration must be given to the effects of motion cues on:

- Tracking
- Failure detection

1. Tracking

With regard to tracking performance, it is generally more important to have the rotational than the translational cues. If tracking performance were the sole criterion, the translational motions might even be eliminated altogether as long as the task did not require a translational acceleration feedback which had no visual equivalent.

The rotary motions should be faithfully reproduced, at least over an appropriate frequency range. A reasonable high frequency limit is 10 rad/sec. This is the approximate bandwidth of the vestibular sensor and is considerably above any manual-control crossover frequencies. For the low frequency limit, it does not appear necessary to go as low as the vestibular sensor washout, roughly 0.1 rad/sec. A conservative lower frequency limit would be 0.5 rad/sec and even 1 rad/sec would be reasonable.

Tracking requirements are also affected by controlled element dynamics. For an easy control task, i.e., requiring little pilot lead, motion cue effects are considerably less than for a difficult task requiring large pilot lead equalization. Fixed-base results may be completely adequate for a good handling vehicle, but overly conservative for a vehicle with poor handling or a marginally controllable task. That is, the absence of rotary motion will incur longer pilot delays in order to extract lead-generating rate data from the visual (error) information. This is illustrated in the Fig. 1 example from Ref. 6, which shows motion effects ($t_z = 0$) on the pilot equivalent visual describing function.

Crossover frequencies and phase margins estimated from the total data (3 Y_c 's, 3 subjects) are summarized in Fig. 2. Reflecting the Fig. 1 trends, we see that with motion cues the phase margins show large reduction (20-40 deg) for $K_c/s(s+10)$, slight reductions (10-25 deg) for $K_c/s(s+1)$, and no change for K_c/s^2 . With less phase lag, the pilot can and does increase his mid-frequency gain and crossover frequency correspondingly.

The above examples show only the overall effects of motion without any details on the mechanism by which the pilot utilizes the motion cues. Using both visual and motion disturbance inputs simultaneously (Ref. 7) allows us to separate the visual and motion feedbacks. An example result is given in the faired curves shown in Fig. 3; also shown are the Y_p data for the fixed-base run. Since the fixed-base Y_p is a visual feedback, comparison of these data and the Y_v data shows how the pilot adjusts his visual feedback when motion cues are added.

We see that when motion cues are present, the visual feedback gain at low frequency is increased and less lead is used in the visual path, i.e., the low frequency phase lags are greater. To the extent that the semicircular canals act as rate gyros, this result might be expected. With the lead information supplied by the motion cues, the pilot does not need to supply as much visual lead as he does fixed-base. He can also increase his gain and achieve a higher crossover frequency because his effective time delay is reduced.

2. Failure Detection

The motion cues accompanying a failure can help greatly in the pilot's timely detection thereof. This is especially true if the visual modality is already heavily loaded with a demanding task. Unfortunately, no general requirements based on failure detection are presently available. As a minimum, the motion should be enough to provide an unambiguous if realistic clue to the failure.

3. Spurious Motion Cues

Another consideration affecting motion simulation fidelity requirements is spurious cues, e.g., associated with false translational accelerations, or washout effects on open-loop maneuvers. An example of the first occurs in a simulator with roll motion but no lateral travel, so that the subject senses a lateral acceleration proportional to roll because of gravity, whereas in an airplane the turn is "coordinated" and acceleration is small.

The second effect is due to the motion washout required because of limited translational travel. As a result initial accelerations are (or can be) correct, but must be quickly reversed to avoid overtravel. Washout characteristics, which might be completely masked in a tracking task, could become quite obvious in certain open-loop maneuvers.

Several moving-base flight simulator experiments were recently performed using roll and sway motions of the Large Amplitude Multimode Aerospace Research Simulator (LAMARS) of the Flight Dynamics Laboratory at Wright-Patterson Air Force Base, Ohio. The objectives of these experiments were:

- a. To tie together roll-only results of experienced pilots with previous results (Ref. 8) for nonpilots.
- b. To investigate effects of various lateral "washout" filters designed to keep the lateral sway (used to imitate realistically "coordinated" free-flight roll maneuvers) within the ± 10 ft limit of LAMARS travel.

The high-pass washouts on lateral beam travel (y_{beam}) were of the general second-order form:

$$\frac{y_{\text{beam}}}{y_{\text{free flight}}} = \frac{K_y s^2}{s^2 + 2\zeta_y \omega_y s + \omega_y^2}$$

where the closed-loop damping ratio, $\zeta_y = 0.70$ was fixed and values of K_y and ω_y were explored. A nonlinear (time varying) washout was also tested where ω_y was continuously adjusted with smoothed roll angle to provide correct cues for small roll, and reduced beam travel peaks for large roll angles.

Two independent inputs were used (as in Ref. 6) to produce behavioral (describing functions) and performance data (error and control scores), on the pilots' use of visual and motion cues while following an evasive (randomly rolling) target and suppressing gust disturbances (Ref. 8). Subjective data were also gathered on the tracking task and on limited "sidestep" maneuvers.

The main results (Ref. 9) show that:

1. The pilots and previous well-trained non-pilots (Ref. 8) exhibited nearly identical behavior and performance, implying universality of adaptation and results.
2. The pilots' roll tracking behavior and performance were not significantly affected by a variety of lateral-sway washouts.
3. The nonlinear beam washout filter reduced the peak lateral motion at the expense of occasionally greater lateral-specific-force (a_y) peaks, but otherwise did not affect behavior or performance. Its primary advantage is the provision of an adaptive washout which does not need to be iteratively fine-tuned to avoid hitting stops while minimizing spurious washout artifacts.
4. Both sidestep and random tracking maneuvers gave rise to spurious lateral motion cues (the coordinated free-flight case would have none) which were characterized as "out-of-phase," "like a student on the rudder pedals," etc. Analysis showed these to be roughly correlated by time- and frequency-response parameters related to sway washout gain, K_y , and frequency, ω_y . Combinations of K_y and ω_y were identified which provided the most acceptable impressions of roll and sway motion realism.

The pilots' subjective impressions of the motion cues were used to define boundaries of acceptable combinations of the sway-axis washout parameters. The resulting "boundaries" summarized in the plot of K_y versus ω_y shown in Fig. 4 (from Ref. 9) appear intentionally nebulous for three reasons:

1. Pilot comments were not always repeatable; changes in the motion cues due to changing K_y and ω_y were deemed very subtle allowing only relative judgments. It was very difficult for the pilots to rate the motion cues on an absolute scale.

2. Pilots were much more sensitive to changes in K_y and/or ω_y for the larger random rolling amplitude than for the reduced amplitude, probably due to an indifference threshold on specific lateral force (approximately 0.1 g, Ref. 10).
3. Pilot comments changed with the task, also probably related to his indifference threshold.

Figure 5 encapsulates the threshold-related effects of comments 2 and 3 above. Figure 5a, for $K_y = 0.9$, shows that for bank and stop (sidestep) maneuvers the peak side forces (A_{y_p}) become "disconcerting" when ω_y is greater than 0.4 rad/sec (coincides with A_{y_p} greater than 0.1 g), but for the reduced input tracking task the pilot sees "no difference" for ω_y between 0.3 and 1.0 rad/sec (where A_{y_p} is less than 0.1 g). Similar results occurred when ω_y was fixed and K_y varied, as shown in Fig. 5b. In general $A_{y_p} = 0.1$ g separates "good" from "bad" commentary in Fig. 5.

Finally one other important comment was the pilots' universal displeasure with hitting the sway displacement limits. The adverse effects of hitting displacement limits have been observed in other simulators (e.g., Ref. 11) and should be prevented by adopting nonlinear motion drive logic.

B. VISUAL SYSTEM FIDELITY

As noted above, good angular rate motion cues serve to provide readily assimilated lead information for those tasks and controlled elements requiring such equalization. In the absence of angular motion the pilot must extract attitude lead information from the visual field. As indicated earlier the mental processing required to do this incurs a penalty in the form of an added pilot's delay time ranging between 0.1 and 0.2 seconds.

The latter figure is for an attitude display or visual content that has at least minimum levels of definition and resolution. There are simulated and flight situations where such is not the case and attitude control, which is a predominant and necessary inner control loop, suffers because of poor visual/display qualities.

1. Texture

A simple case in point drawn from some of our early flight test consulting involved a fighter bomber in a simulated steep diving attack on a desert target, which resulted in a divergent roll oscillation. This problem was directly traced to the lack of texture and detail in the external visual field (flat monochrome sandy terrain) which rendered the perception and use of roll attitude (and rate) information and feedback very difficult. The problem was simply solved by selecting a test site with more coarse texture.

The basic phenomenon -- loss of texture in the visual surround usually occurs under more mundane circumstances, e.g., when fog, simulated or real, intervenes to eliminate fine detail or when the simulated visual scene is too "flat." Texture normally plays an important role in sensing translational rates in all three directions, e.g., (Ref. 12) "-- in the perception of motion and distance;" and in Ref. 13 where the lack of fine detail on the aerial tanker made simulated air refueling difficult. Reference 14 stresses the importance of having a large number of objects in the visual field for the mechanism of streamers to work in the perception of motion.

Some recent tests (Ref. 15) conducted to shed light on data base requirements for computer image generation systems for low speed and hover simulation are pertinent to this topic. The primary objective of the work was to determine the viability of using experimental flight techniques to identify the outside visual cues required to accomplish precise, aggressive low speed and hover tasks. An initial literature review led to concentration on acuity, detail, texture, contrast, and field-of-view as the variables of interest. The basic test procedure was to use electronically fogged lenses to vary the microtexture of the visual external field (lake bed) as a simulation of the lack of such texture on present and near term CGI systems. Large objects, placed in the field-of-view with varying density were easily visible as was the horizon. The level of fogging was empirically set so that the lake bed microtexture became undetectable at otherwise visible ranges corresponding to the view from the upper front window of the Hughes 500D test helicopter while on the ground (a distance of about 27 feet).

A preliminary comparison between current CGI's and the fogged lenses was based on visual acuity scores using standard eye chart, Landholt ring and random E tests for several subjects. It was estimated that the effective visual acuity with fogged lenses corresponds to a resolution between 1 and 2 minutes of arc which is similar to current CGI systems (e.g., on VMS) with a resolution of about 2 to 3 minutes of arc. Therefore, flight test with fogged lenses is at least as good as simulation with a good CGI system. This equivalence is not apparent subjectively because edges in the far and near field are equally sharp on the NASA Ames CGI. This gives the illusion of excellent resolution, i.e., good far vision. The lenses, however, reduce the clarity of distant objects ("texture gradient") as actually occurs with reduced visual acuity in the real-world.

2. Texture and Field-of-View -- Experimental Design

In addition to texture as a key element of the visual scene for a precise hovering task, Ref. 16 hypothesized that a wide field-of-view may be required for hovering a helicopter. Accordingly, the primary objective of the Ref. 15 experimental design was to vary the fine-grained (micro) and coarse (macro) texture as well as the field-of-view in a flight test environment.

The test fields-of-view, intended to approximate those currently available in the VMS and FSAA simulators at NASA Ames, as well as to research those necessary to perform aggressive and precision hover tasks, varied from $10^\circ \times 14^\circ$ to $23^\circ \times 38^\circ$ to $28^\circ \times 38^\circ$ (vertical \times horizontal) for the upper front windshield; zero to $12^\circ \times 16^\circ$ for the lower front; curtained and uncurtained for right door, and pilot's left side.

The field-of-view configurations are summarized and labeled as 1 through 8 in Table 2.

a. Variation of Texture and Detail

The texture was also varied both by patterns on the lake bed, established with tires and 3 ft vertical posts and by the use of painted lines (coarse texture). The IMC Simulator lenses were fogged on some runs to remove the fine-grained texture (cracks in the lake bed). Two main test sites were established to vary the coarse texture (macrotexture): Site 1 provided extensive macrotexture with tires and dashed paint stripes; Site 2 had minimal macrotexture with just enough tires and solid paint stripes to provide orientation with minimal motion cues. The tasks at each test site consisted of a prescribed set of maneuvers involving specific sequences of vertical lift off, hover, sidestep, accelerate, decelerate, bob-up, bob-down, and vertical landing.

The variables in the experiment were field-of-view (Configurations 1 through 8), lenses fogged (corresponding to "RVR = 1/2 mi") or not fogged, and Test Sites 1 and 2. Based on preliminary tests the narrow field-of-view (Configuration 1) was not run with the lenses fogged, because the task difficulty was already excessive. Conversely, configurations with a large field-of-view (7 and 8) were run only with the lenses fogged, since the task was clearly trivial with normal vision.

The data obtained were visual cue ratings on a five point scale for attitude, translational rate, and overall hover cues plus Cooper-Harper pilot ratings and pilot comments. Performance was measured by the times required to do the tasks.

b. Results -- Attitude Cues

The attitude cue ratings (Fig. 6) were fair-to-good with the lenses clear (except for Configuration 1 on Test Site 2). The dramatic degradation in rating with fogged lenses was a surprise considering that the pilots could see the horizon with reasonable clarity; it appears therefore that pilots utilize information in the near field as much or even more than the distant horizon for attitude information in low speed and hover. This tentative conclusion is supported by Ames VMS experience where inadvertent large pitch attitudes (± 10 deg) with rate or acceleration hover response, in spite of a good, distant horizon on the CGI, tend to be suppressed with good attitude markings in a head-up display; and essentially disappear if a good attitude command/attitude hold stability augmentation system is employed. The results here would suggest that low speed and hover attitude control problems on the VMS (for lightly augmented craft) may well be a result of poor microtexture on the CGI. This was an unexpected result in that poor microtexture is typically related to problems with linear translation cues whereas attitude cues are usually related to the pilot's ability to perceive the horizon.

As would be expected, the configurations with a restricted field-of-view were down-rated considerably because of the loss of horizon reference during acceleration and deceleration maneuvers. In fact, some of the pilots gave a separate rating for precision hovering and aggressive acceleration/deceleration maneuvers: these separate ratings were typically a 5, which indicates "poor" attitude cues.

c. Results -- Translational Cues

The cue ratings were generally similar for longitudinal and lateral translation with, as expected, degraded ratings definitely related to the loss of microtexture, i.e., lense fogging. The highly restricted field-of-view (Configuration 1) produced problems with perception of translational rate even with clear lenses (mean cue ratings of 3.8 and 4.5 for Sites 1 and 2), probably due to lack of streamer information in the restricted field-of-view and of all visual references, i.e., the pilots either saw all sky or all ground.

It was surprising to find that for fogged lenses, the translational rate cues were equally poor even with a wide field-of-view and with a substantial macrotexture (Site 1). The inference is that reliance on microtexture for low speed and hover maneuvers is considerable, i.e., pilot ratings for translational rate with the lenses fogged are all in the poor range. It was also surprising that with the lenses clear, small cracks and irregularities on the lake bed surface provided sufficient microtexture for translational rate cues.

The overall hover cue ratings were for the most part, consistent with the attitude and translational rate cue ratings.

d. Cooper-Harper Pilot Ratings (Figure 7)

The Cooper-Harper pilot rating data obtained after each series of runs on each test site are summarized in terms of bar graphs in Fig. 7. These data indicate that there was a major improvement with increasing field-of-view when the lenses were clear. This trend is essentially identical for both sites indicating that the macrotexture was not an important cue in the presence of a well defined microtexture, i.e., small cracks in the lake bed. With the microtexture removed (i.e., the lenses fogged), increasing the field-of-view only gradually improved pilot rating indicating that a well-defined microtexture may be a key pilot cue for precision and aggressive low speed and hover maneuvering.

With the lenses fogged there was a consistent degradation in Cooper-Harper pilot rating when going from Site 1 to Site 2. Specifically, it appears that removing large objects from the field-of-view in an environment with poor microtexture results in a pilot rating degradation of 1 to 2 points (Fig. 7). The pilot rating spreads are also seen to be larger for Site 2 indicating that a higher level of uncertainty existed in that set of environmental conditions.

3. **Sink Rate Cues**

A related example of poor translational cues due to lack of resolution and texture concerns the vertical sink rate cues on the FSAA Camera Model System. There has been general agreement among pilots who have flown the system that the visual and motion cues do not have one to one correspondence with the real world during landing. Early in the Ref. 17 program, it became apparent that what appeared to be a smooth landing was actually firm to hard from the standpoint of computed touchdown sink rate. It therefore appeared desirable to allow the pilots to rate their landing performance based on what they saw on the display. Since all of the pilots had considerable flying experience (greater than 2000 hr) it was reasoned that they should be able to distinguish a good landing from a bad landing.

The first step in the process was to allow the pilots to rate their performance and thereby to calibrate the simulator. The pilot descriptions of touchdown sink rate consisted of "soft, firm, and hard." The pilot-to-pilot variations were small enough to group all of the data and define a relationship between actual performance on the simulator and the pilot's subjective opinion across all pilots. All the landing data were tabulated according to touchdown sink rate and pilot rating (soft, firm, hard) resulting in the three distributions shown in Fig. 8.

Based on these distributions, a numerical rating which distributes the adjectival descriptors essentially linearly with numerical scale was used to correlate the actual (simulated) touchdown sink rate as shown in Fig. 9.

Figure 9 verifies the subjective feeling that what would be a high touchdown sink rate in actual flight (order of 6 ft/sec) looks like a "soft to firm" landing in the simulator. It follows that landing data taken in the simulator (HTD) should be evaluated based on the landing opinion scale in Fig. 9 which indicates a roughly 4-5 fps discrepancy between flight and simulator.

C. **TIME DELAY EFFECTS**

The visual and motion effects and defects discussed above are many times compounded by excessive delay or phase lag between the pilot's input and the system's motion or visual display response. Obviously too long a delay or lag will increase the difficulty of closed-loop control beyond that for the corresponding in-flight conditions; and differences in the phasing delays (mismatch) between motion and visual system responses can lead to cue conflict, pilot confusion, and vertigo. The occurrence and importance of such delays has, if anything increased with the advent of massive digital computation as a substitute for the older-fashioned analog computer implementation of airframe dynamics and mechanical camera model visual systems. A modern computer-generated image system alone typically introduces about an 80 msec time delay which must of course be added to other delays arising from the computation of aircraft dynamics and motion system driving signals. On the other hand total delays on the order of 50-100 msec can have an appreciable influence on performance and workload (Refs. 18-20).

To further understand the effect of various potential sources of transport delays we undertook a computer model analysis (Ref. 21) using a generic vehicle control model as described below. The analysis was carried out to study the effect of several sources of computational delay including host computer system, display system, and motion system.

1. **Analysis Model**

The basic control example was for generic tracking (e.g., dogfighting) where the operator must point his vehicle at a target or aim point at some fixed distance in front of the vehicle. A generic operator/vehicle pointing control model, shown in the block diagram of Fig. 10, has the following features:

- Pilot lead generation to compensate for effective vehicle lag, T_{eq} , inherent in the angular rate feedback, assumed to represent a composite of motion perception (i.e., acceleration, angular rotation and proprioceptive sensations).
- Lightly damped, second-order neuromuscular (limb/manipulator) dynamics.
- Human operator transport delay associated with visual (τ_v) and motion (τ_r) perception.
- System transport delays associated with dynamic computations (τ_c), display generation (τ_d), and motion feedback (τ_m).
- A low frequency trimming operation to minimize "hang off" errors.
- Simplified equivalent vehicle dynamics corresponding to an assumed zero path lag, T_{θ_2} , for this analysis.

2. Transport Delay Sources

The equivalent transport delay associated with dynamic computations (τ_c) can result from the composite effect(s) of stick filters, digital flight control system delays, and control system and other high frequency vehicle dynamics effects. It could also represent the composite effect of A/D and D/A sampling holds, integration routines, and computational cycle time. The analysis considered either no delay, akin to an analog vehicle or an analog simulation computer, or a delay of 75 msec, representative of complicated digital simulation computations or modern high performance aircraft with digital flight control systems.

For the display system delay (τ_d), analysis conditions included either no delay, as for an analog processor, or 100 msec delay common to many current simulation CGI raster scan devices or also associated with terrain board camera servos or digital processing in HUD or EADI instruments.

The final delay (τ_m), due to motion feedback to the human operator, was also either set to zero or to a rather long 250 msec, e.g., associated with a fixed-base environment requiring the operator to generate heading rate cues visually. It could also result from motion lags combined with computational delay in generating the motion base drive commands. Additionally it gives model behavior consistent with past measurements under both fixed-based and moving-base conditions (Ref. 22), and is also consistent with delays identified in flight simulators (Ref. 23).

3. Model Parameter Selection

Other parameters selected for reasons fully explained in Ref. 21 are:

$$\begin{aligned} T_{eq} &= 0.2 \text{ sec} & \tau_r &= 0.05 \text{ sec} \\ K' &= 0.5 \text{ rad/sec} & \omega_n &= 20 \text{ rad/sec} \\ \tau_v &= 0.05 \text{ sec} & \tau_n &= 0.5 \end{aligned}$$

K_r was adjusted to obtain as wide a frequency response as possible in the motion feedback loop while maintaining a reasonable closed-loop damping ratio (i.e., $\zeta_{CL} = 0.5$). Then the closed-loop response of the motion feedback loop can be approximated by a gain and an equivalent time delay (below the point of amplitude ratio roll off), i.e.,

$$\text{Motion Feedback Closed-Loop Response} \approx K_{eq} e^{-\tau_0 s}$$

The closed-loop equivalent parameters are given in Fig. 11 in parenthesis.

4. Equivalent Operator/Vehicle Time Delay Effects

The equivalent closed-loop time delays for a range of motion feedback delays (τ_m) and two levels of computational delay illustrated in Fig. 11 shows that the computation delay (τ_c) has a much greater influence on the equivalent closed-loop delay than the motion delay which is actually in the feedback loop. On the other hand, a significant motion delay, as in the lower right-hand corner of Fig. 11, reduces the closed-loop bandwidth of the heading rate loop considerably -- in this case to the vicinity of the "bare" vehicle's heading rate time constant (i.e., delayed feedback effectively opens the loop). Regardless of component cause the increased equivalent closed-loop time delay will in turn reduce the achievable overall outer loop bandwidth.

Corresponding to the Extended Crossover describing function for the Fig. 10 model,

$$Y_p Y_c = \frac{s + K'}{s} \cdot \frac{s + U_0/R}{s} \cdot \frac{\omega_c e^{-\tau_e s}}{s} \quad (1)$$

Low Frequency Trimming
Low Frequency Aim-point Kinematics + Integration
Crossover Model

the Fig. 12 example $Y_p Y_c$ transfer functions, which include the low frequency aim point kinematics $(s + U_0/R)/s$ plus trimming $(s + K')/s$, result in a conditionally stable system. The aim point lead, U_0/R was varied for each combination of the various time delays in order to get a similar stable phase region for all conditions. Once this form had been achieved, K' was selected to give a specified phase margin at the crossover frequency (bandwidth) of the closed-loop operator/vehicle control system. For this analysis an attempt was made to maintain a constant phase margin of 30 deg for all cases.

5. Bandwidth Effects

The results of the above procedures and variations can be seen in Fig. 13. Observe that the control bandwidth of the operator/vehicle system drops dramatically as various delays are added into the simulation loop. Adding the 0.1 sec display delay (τ_d) has the largest single impact on equivalent time delay and system bandwidth; motion cue delays have the least, and computational delays are in between. However, if the computational delay were increased to an equivalent 0.10 sec, its effect would probably be greater than the (0.10 sec) display delay effect. When all the delay sources were combined, the system bandwidth was cut by more than 50 percent.

We can use the Fig. 13 hyperbolic relationship, $\tau_e \omega_c = K$, to determine how effective system time delays affect achievable bandwidth. Assume that a 25 percent decrease in system bandwidth is permissible. Then

$$\frac{\omega_c'}{\omega_c} = 0.75 = \frac{K/\tau_e'}{K/\tau_e} ; \tau_e' = \frac{\tau_e}{0.75}$$

or

$$\tau_e' - \tau_e = \frac{1}{3} \tau_e \quad (2)$$

Thus, an increase of one third in the total effective system time delay (τ_e) would be acceptable. For responsive real world systems with a bandwidth of 4-5 rad/sec which result in an effective time delay on the order of 170 msec, such an increment in time delay due to simulator characteristics, could be on the order of 50 msec. (Maximum time delays on the order of 40-60 msec have previously been recommended, Ref. 24.) For sluggish real world systems where effective system time delays might be 0.3-0.4 seconds, incremental time delays on the order of 100 msec might be acceptable. However, these "linear" considerations do not account for the fact that the achievable bandwidth, in turn, has an effect on the allowable time delay for good flying qualities (Ref. 64).

Regardless of the value of the constant in the Fig. 13 relationship, the tradeoff between system bandwidth and effective system time delay is fundamental, and gives some insight into the consequences of added computational delays, whatever their origin.

6. Delay Compensation

Delay compensation can be considered at various stages in the system architecture. Minimum delay integration routines should be considered for dynamic computations (Ref. 25). The update of motion and angular orientation cues are more critical to closed-loop operator/vehicle system response than outer loop translational information that is already delayed by kinematic integration. Thus in computing equations of motion, angular rates and orientation, and accelerations should be updated more rapidly than inertial velocity and position. In CGI display systems, angular transformations should be updated more rapidly than perspective transformations.

Lead or rate compensation might be considered for both host computer and CGI computations. For systems with adequate motion cues, lead frequencies in the region of the human operators limb/manipulator bandwidth (> 10 rad/sec) might be acceptable. In general lead frequency must be above system crossover frequency (ω_c) to avoid compromising system gain margin.

D. HIGHER ORDER SAMPLING EFFECTS

Of course the effective delay introduced by the sampling effects of digital computation is an approximation to more complex effects which occur at multiples of the sampling frequency. Some example effects for simple controlled elements are given in Ref. 26 as discussed below.

A selection of the cases studied and the results obtained are shown in Fig. 14. First a description of the three cases illustrated by the inset block diagrams.

The situation described by Case I assumes a controlled element ($1/s^2$) under the influence of a continuous feedback controller with an (idealized) compensation network $2(s+1)$ in the forward path. Case II depicts the same controlled element under the influence of a discrete feedback controller which smoothes the output of the digital computer with a zero order hold (ZOH) which passes on a "staircased" signal to the control point. The discretized version of $2(s+1)$ was computed, using the z transform model $(42z - 40)/z$ (at a sampling rate of 20 Hz). Case IV depicts a situation where one part of the simulation is coded for one computer while another part is coded on a second computer. Typically, the computers are working in different frame times and therefore will, on occasion, pass "old data" back and forth. It is assumed that the compensation is modeled in a 0.05 sec time frame, while the plant is modeled in a 0.075 sec time frame. Data transfer between the two computers is via appropriate buffer registers, modeled as a ZOH in a T/3 time frame (M_3) and a ZOH in a T/2 time frame (M_2).

Results

Inspection of the Case II results discloses no surprises. The digitally controlled system is a reasonably faithful reproduction of the analog system until the folding frequency (approximately equal to 62.8 rad/sec = 1/2 sampling frequency) is passed. Notice that in the discretely controlled system, minimum response points (notches) in the Bode plot occur at multiples of sampling frequency (125.66 rad/sec). Comparing the two independent processor, Case IV, against the continuous baseline design shows large, sharp resonant peaks introduced in the aliased bands corresponding to integer multiples of the $T/2 = 0.075$ sampling frequency and, in addition, there is a large overshoot in the first fold.

There are significant differences in spectral content which would be hidden if we looked only at the frequency content from zero to the first folding frequency. Even in the first fold, there is a significant difference in the Bode plot of the continuous case and the two-rate simulation. Such differences could be very significant if the system bandwidth required, e.g., to control elastic modes in a real case, extended beyond the first folding frequency.

III. DIAGNOSTIC TOOLS

The original and still an acceptable technique for judging simulator fidelity is to solicit the pilot's opinion and detail commentary. Of course this requires that he have flight experience in the simulated aircraft, systems, workload, and flying task environment. This technique is especially useful in pinpointing differences between simulated and real aircraft responses because the pilot can be relatively specific about such differences. However, differences due to vision- and motion-system shortcomings are more subtle and difficult to pinpoint.

A. RATING SCALES

To formalize and focus the pilot's attention on visual cues we utilized (in Ref. 15) rating scales (noted earlier) as shown below. The pilots were encouraged to assign decimal ratings (i.e., 2.4 is a valid rating) since the adjectives "good," "fair," and "poor" are semantically linear (see Ref. 27). The definition of "good," "fair," and "poor" cues were taken from the proposed revision to the helicopter flying quality specification reported in Ref. 28. They are:

- Good cues are easily and quickly perceived allowing pilot to make aggressive corrections with confidence.
- Fair cues require considerable concentration to perceive accurately, allowing pilot to make only moderate corrections or changes with confidence.
- Poor cues require full concentration to perceive enough information for aircraft control. Only small and gentle corrections are possible, and consistent precision is not attainable.

The foregoing definitions are primarily intended to apply to cue degradations, e.g., due to simulated or real fog or nighttime conditions but are applicable also to cockpit displays intended to augment (degraded) outside visual cues.

A more general rating scale used in the Ref. 29 work is given in Table 3. This is less specific as to cause of defect and is clearly angled mostly toward vehicle discrepancies as indicated in the descriptions of the first three categories. However, in actual use (Ref. 29) pilots included consideration of wake turbulence realism and visual cues as indicated by the commentary quoted below.

"Winds were increased to 330/43 -- the initial turbulence appeared to be less than might be actually encountered with 43 kt winds. Overall simulator rating for these runs is 4 (simulator needs work...but is useful for general handling qualities investigations for this class of aircraft). Airwake turbulence effects were increased and the approach reflown. During a second re-fly the aircraft was maneuvered about the flight deck to assess turbulence affects -- overall simulator rating 2.5 - 3."

"It was not possible to anticipate ship motion during the approach or hover phases since the ship seemed to pitch and roll in an undefined blue environment; there were no waves or wind streaks to compare deck motion for perspective. Overall simulator rating 4.5."

"Validity of VMS as a simulation of the SH-60D (refer to Table 3). Vertical response = 4 -- hover height determination/maintenance is difficult due to CGI lack of depth perception/adequate cues -- considerable pilot effort required to maintain hover position over deck and make landing due to CGI lack of depth perception/adequate cues, aggravated by deck motion."

B. PILOT DESCRIBING FUNCTION BEHAVIOR

A better metric of simulator fidelity is the quantitative measurement of pilot control behavior. Figures 1 and 3, previously discussed, are examples of such but required the imposition of "artificial" disturbance inputs. A method which needs no such "intrusive" disturbances has been developed and used more recently. The theoretical basis and the computational details for this method are given in Ref. 30. The central analysis concept consists of a running least-squares correlation of a dependent variable, y , with one or more elements of an independent variable vector, X . It uses sampled data correlation with a sliding "window" in the time domain and least squares estimation to provide the time-varying pilot describing functions. The procedure is mathematically simple, but its success depends upon the judicious choice of an assumed pilot control strategy, Y_p . This, in turn, depends upon the experience of the experimenter, knowledge of the control task, and a thorough understanding of the dynamics of the controlled element, Y_c . It is essential that the analyst choose a likely candidate control strategy in order for the subsequently estimated parameters of the control strategy to be valid. The method does not require the use of special inputs, although some level of turbulence or other disturbance, real or simulated, is needed to excite desirable control/response activity. Some example results of its use follow.

1. Bob-up Maneuver

The first example is the bob-up maneuver data from Ref. 31. The expected pulsatile nature of the pilot's control indicated by the time-optimal characteristics of Fig. 15 was measured both in-flight and in the simulator; the results are shown in Figs. 16 and 17.

Since $-Z_s/s(s-Z_w)$ represents the predominant quasi-linear height response dynamics to collective control, we would expect the distribution of time intervals from an ensemble of bob-ups in flight to be bimodal (i.e., Fig. 15). The results in Fig. 16 show that the distribution of control pulse intervals is indeed generally bimodal in flight and corresponds approximately to the theoretical optimum. However, Fig. 17 shows that the distribution of control pulse intervals for the bob-ups in the Vertical Motion Simulator is unimodal, which is more appropriate for controlled element K_C/s^2 . One interpretation is that the pilots do not perceive heave damping in the cockpit of the vertical motion simulator, despite the mathematical model identified as $0.6/s(s + 0.3)$. This interpretation is consistent with numerous pilot complaints about a "severe lack of damping about all axes."

Another aspect relates to the bob-up error reduction phase which begins as the pilot approaches his desired bob-up altitude. The controlled element (Y_c) for the error reduction phase remains $K_C/s(s + 1)$, which requires only first-order lead-lag equalization by the pilot for closed-loop regulation of height in the presence of disturbances.

The error reduction phase of the simulated bob-ups exhibited more aggressive control, lower damping ratios, and larger dynamic errors than in flight. The initial overshoots were about twice those in flight and the closed-loop damping ratios approximately half those in flight. The underlying reason(s) for pilots' comments about lack of heave damping is revealed by the piloting characteristics identified in Table 4.

In particular, the pilot's effective transport delay increases from approximately 0.3 sec to 0.5 sec indicating that lead compensation is being generated predominantly in the visual modality (Ref. 46). Over the crossover frequency range from 0.5 to 1.0 rad/sec, the phase advance generated in the acceleration cues by the simulator washout is 85 to 57 deg, respectively, with respect to the visual CGI (Fig. 29 discussed later). This certainly has the potential to confuse the pilot and lead him to effectively ignore the simulator motion cues; such a conclusion is at least compatible with the evidence.

2. Hover Turns

Analysis of the piloting technique, in executing hover turns in flight, usually exhibited a pure gain control describing function. In the simulator, each pilot, as for the bob-ups, consistently generated lead compensation near his crossover frequency, and this resulted in a much higher crossover frequency in the error reduction phase, which caused the pilot to work harder. The average pilot crossover frequency and the closed-loop damping ratio results are presented in Table 5.

The spectral region where phase distortion associated with the measured yaw motion washout is least in the simulator (refer to Fig. 29 for "typical" VMS motion phasing), is also the region of the identified pilot crossover frequency in the simulator. If, in the simulator, the pilots had tried to adopt a crossover frequency in the range of 0.48

to 0.62 rad/sec, where the flight crossover frequency was identified, the significant motion lead present in the simulator would cause disparate motion and visual cues during the error reduction phase of the maneuver. In effect, the pilots avoided the motion phase distortion region by going to higher crossover frequencies.

C. PHASE PLANE ANALYSIS (REFERENCE 32)

Identification of the dominant closed-loop response mode via phase plane trajectories (plot of rate vs. displacement for a given state) is a useful technique for analyzing transient maneuvers. The particular state to be considered is that of the discrete command. For a heading change maneuver one would inspect heading rate plotted against heading displacement; for hover position, closure rate versus range; or for altitude change, vertical velocity versus height.

A first-order dominant mode can be distinguished from a second-order one depending upon the relative curvature of the trajectory. (Various texts can be consulted for an in-depth treatment of phase plane analysis, e.g., Refs. 33 or 34.)

1. Landing Flare

Figure 18 is a sample of a DC-10 landing flare phase-plane which illustrates second-order-like behavior, at least during the latter portion of the trajectory. From other similar trajectories it was found that a fairly large sample of pilots preferred a closed-loop damping ratio of about 0.7 ± 0.1 and a closed-loop natural frequency of about 0.4 ± 0.1 rad/sec. Such properties tend to provide consistently good decay of sink rate from a wide range of initial conditions, off-nominal aircraft flight conditions, or variations in flare maneuver aggressiveness. Knowing the vehicle flight path dynamics and that rate feedback must be involved to explain the large closed-loop damping, the effective pilot-vehicle form for the landing maneuver is given by

$$Y_{pY_c} = UK_H(1 + T_I s)/s(1 + T_I s) \quad (3)$$

By expanding the closed-loop characteristic equation, the open-loop parameters T_L and T_I can be related to the second-order closed-loop parameters ζ_{FL} and ω_{FL} :

$$2\zeta_{FL}\omega_{FL} = \frac{1}{T_I} + \omega_{FL} T_L \quad (4)$$

In turn T_L and K_H can be used to ascertain crossover frequencies and effective feedback gains as in the Table 6 comparisons between flight and simulation.

The most obvious difference between simulator (Redifon NOVVIEW United Airline DC-10 training simulator) and flight, was in the firmness of landings, as reflected in the ratio of sink rate decay, h_{pp}/h_{max} , and the effective damping ratio, ζ_{FL} . At the same time, the abruptness of the flare maneuver and corresponding height feedback were comparable between simulator and flight. A related important piloting technique implication is that sink rate feedback is inadequate in simulator landings. A further implication is that a cue deficiency exists. The exact nature of the corresponding cue deficiency is not clear from the data although visual perception of sink rate is suspected (as in the Ref. 17 results discussed earlier).

2. Helicopter Speed Control

Similar phase plane analyses are applied in Ref. 32 to in-flight helicopter speed control (through θ) to show the variations in cues used and in the abruptness required in the attitude response, as summarized in Table 7.

Comparable phase plane analyses of an Army UH-60 training simulator quick-stop maneuver performed by an instructor flying at low altitude over a runway resulted in,

$$K_R = 0.2 \frac{\text{deg}}{\text{kt}} \text{ and } K_r = 0$$

Comparing these values to the 4 deg/kt and 1 deg/ft, respectively, estimated from flight, we see that in the simulator the closure-rate feedback was more than an order of magnitude smaller and that the range feedback was essentially nonexistent. Such a disparity could, of course, discourage use of the simulator for that particular maneuver, but can also help to identify the source of simulator fidelity problems. In the case cited above, it is likely that a contributing limiting feature was the obstructed downward field-of-view over the nose.

In addition to the data in Table 7, the decelerating approach to hover also yields an estimate of the apparent distance, A , of vanishing points in the visual perspective (Ref. 1). The values obtained from analysis of the decelerating flight phase plane data range between 400 and 600 ft which agrees with recent out-of-doors field measurements in daylight (Ref. 35). Analogous test measurements for the same subjects viewing collimated and uncollimated closed-circuit TV views of the same outdoor conditions yield the following comparative results for A .

Out-of-doors, daylight	530 ft < A < 680 ft
Collimated TV monitor, daylight	216 ft < A < 239 ft
Uncollimated TV monitor, daylight	66 ft < A < 115 ft

The results imply that the collimation tended in part to compensate for the distortion of the visual perspective associated with direct viewing of the TV monitor (Ref. 36).

To summarize, the apparent distance, A, of vanishing points in the visual perspective can be estimated from a variety of experimental tests in flight and in simulators. The values of A so obtained offer a unique measure of the fidelity of visual perspective and resultant depth perception.

IV. SIMULATION VS. REAL WORLD

In spite of the potential accumulation of the various errors and artifacts noted above, simulation can be an extremely useful, effective, and accurate counterpart to the real world. Our own experience in this regard are reviewed below for both fixed-base relatively simple and moving-base highly-sophisticated simulators.

A. FIXED-BASE SIMULATIONS

The first example, an old one (Ref. 37), concerns the fixed-base simulation of beam-aided manual control of the landing approach to an aircraft carrier.

1. Carrier Approach

The complete picture of the landing system is given in Fig. 19; the simulation was confined to the pilot airframe end (right side) of the figure. The primary problem was to provide a sense of reality and realism to the pilot's display(s) and manipulators in the context of the task. This was accomplished in a series of progressive improvements as detailed in Ref. 37 in response to both pilot commentary and simple data analysis. The final display integrated the aircraft motion quantities ϕ , ψ , θ , and h via a two-gun oscilloscope into a time/range-varying display as depicted in Fig. 20. This display simulated the pilot's outside view of the Fresnel lens system currently used on aircraft carriers, the line segment and dot corresponding to datum bar and glide path "ball," respectively. An inside-the-cockpit view was sketched on the CRT face for a more effective inside-out representation to the pilot as illustrated in Fig. 20(a). Display scaling of the basic motion quantities illustrated in Fig. 20(e) is summarized in the appended Fig. 20 Table. This scaling was in accordance with the "porthole view" concept described in Ref. 38. The time duration of the approach was expanded somewhat (i.e., a relative velocity of aircraft to carrier of approximately 73 kt) to permit a longer evaluation time. Mirror beamwidth limits were mechanized to simulate loss of the meat-ball occurring for flight excursions in excess of the standard 1.5° beamwidth which was inclined 4° to the horizon. Pilots considered the display as fairly representative of carrier approaches made at night.

In addition to the CRT presentation, airspeed, pressure altitude, thrust, and angle of attack (continuous and "indexed") were displayed in the cockpit. The angle of attack error (from nominal) was "indexed" to progressively light discrete symbols: "doughnut" for $\pm 0.50^\circ$ or less, doughnut and "chevron" for $\pm 0.5^\circ$ to 1.0° , and chevron for $\pm 1.0^\circ$ or greater.

Based on the data collected and analyzed in this simple simulation we were able to postulate a (compensatory multiple loop) model of pilot and pilot aircraft behavior to which we then attached the remainder of the Fig. 19 system elements (Ref. 39). The total system was then exercised, together with a probability-tree landing system performance matrix, to predict the dependency of accident rate on approach speed as shown by the dashed curve in Fig. 21. Recognizing that the heave damping parameter $1/T_{\theta_2}$ is a significant factor in path performance, explains some of the more notable apparent discrepancies between the predicted and actual accident rate vs. approach speed in Fig. 21. For example, the difference in accident rates for the A-3 and A-4 aircraft, which have approximately the same approach speed, appears to be explainable by their dissimilar $1/T_{\theta_2}$ values. Also, the F-4's accident rate, higher than expected on the sole basis of approach speed, may be significantly influenced by the small magnitude of its $1/T_{\theta_2}$ value.

The success of the model in such predictions led eventually to its application to the analysis, design, fabrication, and installation of a new Fresnel lens stabilization and control system (Ref. 40) which promises to significantly improve carrier approach and landing performance and safety.

2. Alcohol-Impaired Drivers (Reference 41)

A second example concerns a similar set of extrapolations based on fixed-base simulation results of alcohol-impaired drivers. A feature of some of these simulations was the imposition of additional workload on the (driving) control task. For example, in a decision-making experiment, drivers were required to estimate their probability of entering an intersection before a yellow light changed to red. In addition they were

required to weave through roadway "boxes" in a double lane changing task; and to avoid an unexpected obstacle (a simulated vehicle backing out of a driveway).

The "accident" probabilities deduced from such tests and data are compared with the data obtained in real world crashes (Fig. 22). The data from the simulator studies compare favorably with the real world data.

3. Shuttle Orbiter PIO

A third fixed-base simulation which has real world connections is that used to study the shuttle PIO incident (Ref. 42). The main feature of this simulation was a display which created a sense of urgency by requiring timely completion of the landing maneuver to touchdown. The problem was, using a fixed-base task (not normally PIO sensitive), to develop a sense of urgency and a need for fast response with the limited available display capability (a two-gun CRT), while also maintaining a reasonable approximation to a real-world approach and landing situation. The final display used is shown in Fig. 23. Attitude information is provided by a moving horizon relative to a fixed reference -- a conventional inside-out display. Path information is provided by a "ground plane" line which moves up and down in proportion to altitude at the pilot station. The task starts with the ground plane at the bottom of the CRT screen corresponding to a wheel height of about 18 ft and a slightly nose-down pitch attitude with a corresponding positive sink rate. Once the task is started, the ground plane moves up the screen and its length shrinks to a dot at the end of 9 sec. The pilot's task is to stop the ground plane on the fixed reference as smoothly as possible without overshoot before the length of the line shrinks to zero. If the pilot achieves zero h_p before the allotted time, he must try to maintain the ground contact. If the length of the line goes to zero before achieving the desired steady ground contact, it is considered analogous to stalling above the runway.

Typical Orbiter and YF-12 (an easy airplane to land) simulation responses, shown in Fig. 24, are quite different in nature. In the YF-12 the pilot was able to make the desired path correction quickly and smoothly and had no problem in maintaining the desired altitude; only small attitude corrections were used. In the Orbiter, large attitude excursions occurred, and both attitude and altitude traces were oscillatory. Repeated trials with both aircraft consistently showed these differences. Furthermore, although quite crude, measured closed-loop Orbiter frequencies (e.g., identified in Fig. 24) tend to confirm that the tight control provoked by the task corresponds quite closely to the analytically derived PIO region which correlated with the flight results.

4. Roll Ratchet

The final fixed-base simulation example (Ref. 43) is one where detailed pilot-airplane describing function measurements are used to infer incipient instabilities corresponding to flight-encountered "roll-ratchet."

The experimental goals were to investigate and quantify human operator limb/manipulator dynamics and interactions between the neuromuscular subsystem, force sensing side-stick configuration, high gain command augmentation, and command filtering; and to investigate possible relationships between these interactions and the roll ratchet phenomenon. A longer range goal is to provide and enhance guidelines for manipulator-system design.

The experimental setup used a roll tracking task in which the pilot matched his bank angle with that of a "target" having pseudo random rolling motions obtained via a computer generated sum of sine waves. The controlled element approximates a high gain roll rate command system with an effective roll subsidence time constant or a flight control system prefilter (T), whichever is larger. It also includes a pure time delay (τ) which for very small values of τ , may be a realistic approximation to digital flight control system sample and hold dynamics. The parameter values for T and τ used in the experiment were consistent with those for a modern flight control system designed to have Level 1 flying qualities. Thus, they should produce excellent effective controlled elements providing the gain is appropriately adjusted.

The sidestick manipulator variables included three stick displacement configurations: fixed (no displacement) as in the F-16; (Ref. 44) 0.77 deg/lb (small) stick motion; and 1.43 deg/lb (large) stick motion. The latter two matched the displacement/force characteristics employed in an NT-33 flight test (Ref. 45). Analog signals from the manipulator force sensor (p_c) and the resulting roll response ϕ were passed through an A/D converter to a digital computer where describing functions and various performance measures were computed using STI's Frequency Domain Analysis (FREDA) program. The computations were essentially on-line and printed out at the conclusion of each run. Some 530 data runs were accomplished which provided a tremendous data base from which to determine or identify the various interactions of interest.

Since roll ratchet had not previously been observed or recognized in fixed- or moving-base simulations the first objective of the experiment was to tune the controlled element, manipulator, and command/force gradients to try to obtain roll ratchet, or at least maximize roll ratchet tendencies, in the fixed-base simulation. A key factor based on our pre-experiment analysis was that describing function measurements must cover the limb neuromuscular peaking frequency region (Ref. 46), and forcing functions should be adjusted to emphasize good data in the neuromuscular subsystem region.

Figure 25 presents example describing function measurements for 3 runs using the fixed force stick and a controlled element having a command/force gradient of 4 deg/sec/lb, no time lag (T), and a time delay of about 70 ms. Amplitude departures from the straight line (which reflects the expected ω_c/s crossover characteristics) are the pilot's neuromuscular system contributions at high frequency and his trim lag-lead at low frequency. The highest 3 frequencies shows a peaking in the vicinity of 14 rad/sec for 2 of the 3 runs; and there is remarkable consistency in both amplitude and phase measurements across all frequencies for all 3 runs. Two of the amplitude data points at 14 rad/sec lie slightly above the 0 dB line. This represents a neutral or slightly unstable dynamic mode if the phase angle is near -180 deg at this frequency. This then could be interpreted as effecting roll ratchet.

The peaking tendency shown is representative of a large amount of the data obtained; and this frequency is consistent with the roll ratchet frequencies observed in the flight traces.

Additional measurements and correlations in Ref. 43 show that the peaking tendency:

- is maximum (7 dB mean) for a time delay, τ , of 0.065 to 0.070 sec; (4 dB at $\tau = 0.10$ and 2 dB at $\tau = 0$)
- is not strongly influenced by command force gradient (9 ± 2 dB over 3-15 deg/sec/lb); and shows about the same (above) tendencies with τ for the fixed and small deflection sticks, and no such tendency for the large deflection stick

Certain of the experimental controlled elements essentially duplicate the F-16 configurations tested in-flight (Ref. 44) and the qualitative results and trends are the same. The compromise prefilter for the F-16 has a time constant of 0.2 rad/sec which is shown in Fig. 26 to allow a comfortable bandwidth slightly above 3 rad/sec with 30 to 35 deg of phase margin and a generally reduced neuromuscular peaking tendency. Thus there should be minimum tendency for high frequency PIO although the data scatter in the higher frequency range of Fig. 26 show that conditions favorable to roll ratchet could pop up from time to time.

Another comparison between simulation and flight can be drawn from the investigation of roll ratchet and various prefilter configurations flown in the NT-33 (Ref. 47); however, a major difference was the use of a center-stick in the NT-33. The roll ratchet encountered in this flight test was at approximately 16 rad/sec.

Figure 27 includes this and other data in a plot of command/force gradient versus the roll time constant, T_R . The circles identify configurations flown; the open symbols reflect no ratchet obtained, the shaded symbols reflect roll ratchet observed by one or more of the evaluation pilots over the range of time delays investigated. (In almost every case, ratchet only occurred with non-zero τ as in the lab simulation.)

The square symbols in Fig. 27 are configurations investigated in the fixed-base simulation. The open symbols identify configurations for which the $Y_p Y_c$ zero dB line did not pass through the neuromuscular peak (no ratchet possibility). The shaded squares identify configurations for which the zero dB line passed through the peak (ratchet possibility). The letters F, S, L reflect the displacement characteristics of the simulator side-stick. It is likely that the L side-stick most closely matched the NT-33 center-stick characteristics.

There is very good correlation between the flight and lab simulation ratchet tendencies shown in Fig. 27. The dashed line appears to separate the non-ratchet from the ratchet configurations except for the two or three lowest command/force gradient configurations at $T_R = 0.2$ sec. It is possible that this difference may be related to wrist (simulation side-stick) versus arm (flight center-stick) neuromuscular subsystem contributions at the lower command (higher force) configurations. The good agreement between flight and simulator results is interpreted as an encouraging validation of the simulator definition of ratchet potential -- i.e., neuromuscular peaking cut by the $Y_p Y_c$ zero dB line.

B. MOVING SIMULATIONS

As an important part of a helicopter flying qualities specification effort, we have been directly involved with simulation and in-flight comparisons in order to identify believable simulation data. One of these comparison studies has already been reported to AGARD in Ref. 31, but will be briefly reviewed here for completeness and continuity.

1. UH-60 Flight, Simulation Comparison

These comparisons reflected the hypothesis that if the simulator can induce "correct" piloting technique then presumably the simulation fidelity is adequate; with correct piloting technique for the purpose of the Ref. 31 investigation being defined as that measured in flight with a UH-60A Black Hawk helicopter. Six flight-test maneuvers were chosen for evaluation in the simulation validation experiment: (1) bob-up, (2) hover turn, (3) dash/quickstop, (4) sidestep, (5) dolphin, and (6) slalom. The simulated NOE course flown was a Z shaped canyon 38.1 m wide and between 15.24 m high (treeless) and 18.3 to 30.5 m high (with trees). The "standard" simulator configuration

included the most up-to-date UH-60A mathematical model available, the four-window CGI, and a motion drive algorithm that provided the most realistic motion possible.

Qualitative Cooper-Harper pilot ratings, obtained both in flight and during the simulation for each NOE maneuver (or task) are presented in Fig. 28.

All of the tasks were rated Level Two ($3.5 < \text{HQR} < 6.5$) in the simulator, whereas all were rated at Level One ($\text{HQR} < 3.5$) in flight. When considering these results, one concludes that "something was different" in the simulator which caused a degradation of approximately 1.5 to 2 HQRs. As can be seen, no overlap exists in the rating values.

A detailed review of the pilot comments identified the characteristics of the simulation judged by them to be not representative of flight characteristics, as follows:

- Larger thresholds of visual perception of movement
- Inability to judge range and height as accurately
- Insufficient scene content and texture in CGI
- Insufficient cockpit field of view
- Deceptive motion cues -- only the initial cues feel correct
- Insufficient damping in all axes of simulated rotorcraft
- Vertical PIOs and roll PIOs (PIO = pilot-induced oscillation)
- Exaggerated collective control "pumping"
- Exaggerated cyclic control inputs
- Stabilator-induced dynamics absent
- Excessive pilot workload

Not surprisingly, these "problems" can be attributed to any as well as all of the three major simulation components -- the visual CGI system, the vertical motion system, and the Black Hawk mathematical model.

Some of the motion and visual system problems of this particular simulation have already been discussed above. The mathematical model was compared with flight responses and an example comparison is shown in Fig. 29 for the vertical acceleration response to collective in hover. Also shown is the VMS cab vertical response (with second-order washout at 0.3 rad/sec) which provides a significant amount of phase advance in cab motion: at 0.6 rad/sec, motion phase advance over the mathematical model is approximately 80 deg; at 1.0 rad/sec, approximately 50 deg. Cab motion is in phase only at approximately 1.65 rad/sec, above which it lags the mathematical model. There is also a visual scene delay due to a 120 msec transport delay caused by the digital computation cycle time which increases the disparity between visual and motion cues (below about 2 rad/sec).

One very practical conclusion drawn from the above comparisons is that for a basic rate-damped FCS (as in the UH-60) the simulator is pessimistic by about 1-1/2 Cooper-Harper rating points.

2. MIL-H-8501 Flight: Simulator Considerations

In connection with the ongoing helicopter flying qualities specification effort (Ref. 48) additional comparisons between all available pertinent flight and simulation data have been made (Ref. 49). For example, Fig. 30 for hover and low speed conditions summarizes pilot rating data for Rate Response-Type (including RCAF) command augmentation from the flight experiments of Refs. 50 (source report for Ref. 31), 51, and 52, and the simulation results of Refs. 50, 53, 54, and 55. For the shipboard landing data, Refs. 53 and 55, the ratings are for the most benign conditions (i.e., Sea State 0). Ratings are plotted versus lateral bandwidth, ω_{BW} , (Ref. 56), with longitudinal bandwidths (listed on Fig. 30) essentially constant for all cases.

Although more flight data would better substantiate the differences, the average curves for simulation and flight in general show simulation configurations rated 1 to 2 points worse than flight configurations with similar bandwidths. The bandwidths, incidentally already include the visual and motion system delays; so other more subtle factors as discussed earlier are obviously more significant. One of these may well be differences in the field of view for real landings and those simulated on the VMS. The lack of fine detail or microtexture available on the CGI would also affect ability to hover.

The effect(s) of a change to an attitude command/attitude hold (ACAH) control system may be seen in Fig. 31. Here there is no corresponding flight comparison but the better rating trend with bandwidth than in the Fig. 30 simulator data is an obvious difference. Furthermore, with a bandwidth of about 3 rad/sec the average ACAH rating is about the same (ca 3-1/2 ~ Level 1) as that for the flight test rate response system (Fig. 30).

In effect the attitude command feature makes up for the simulator's deficiencies when attempting low speed and hover with a rate system. (Recent NRC variable stability helicopter tests indicate that similar Level 1 ratings can be achieved in-flight for ACAH at a lower bandwidth -- approximately 2 vs. the 3 rad/sec shown.)

Figures 32, 33, and 34 are all for constant speed instrument approaches with no Flight Director display and show the effect of system response type. Recognizing that the right-hand side of Fig. 33 (the appropriate data are those for turbulence) basically involves a similar progression from rate damping to ACAH as in Figs. 32 and 34 shows that the comparison between flight and simulation is much better for up-and-away, than for hover-type-flight. Another overall conclusion based on these data is that attitude hold is necessary for Level 1 operations in IFR approaches.

The effects of three-axis flight directors (longitudinal and lateral cyclic and collective directors) integrated into the ADI are shown in Fig. 35, together with the raw data (no flight director) pilot ratings discussed earlier in Fig. 33 and replotted here. There is no obvious improvement in pilot ratings due to the flight director.

Figure 36 data taken in the NASA AMES VMS simulator show a similar lack of flight director effect and further show about the same PR's as the Fig. 35 flight data.

For decelerating approaches the Ref. 62 simulation involved a 6 deg approach with an essentially constant-attitude deceleration, resulting in an initial deceleration of about 0.045 g slowly decreasing to 0.035 g near hover. Pilot ratings, summarized in Fig. 37, show improvement with either increased flight control automation or with use of a flight director.

Unpublished data, from a recent flight study using the Bell 205A variable-stability helicopter (Ref. 63), are shown in Fig. 38. The task involved decelerations on a 6 deg glide slope from 60 kt to approximately 22 kt, and a decision height of 50 ft. The deceleration profile was roughly constant-attitude with a rate of about 0.1 g at the beginning. The flight director was worth about 2 pilot rating points, which is generally consistent with Fig. 37. However, now we see very little difference between the rate damping and ACAH SAS types. The rating levels for ACAH for simulation and flight are very comparable; but those for rate damping are much higher in the simulator -- similar to our previous observations for visual hovering.

V. CONCLUSIONS

The foregoing examples and experiences lead to the common conclusion that simulator fidelity is not an absolute quantity, but rather a relative quality; and that generally even the best of the large scale research simulators impose restrictions on the types of situations and tasks that can be faithfully simulated.

The simulated task is a strong, perhaps the central, issue. An aggressive task will suffer most from inadequate or conflicting motion and visual cues. Thus the simulations of aggressive helicopter maneuvers were influenced by the:

FCS types; automatic flight control (e.g., ACAH) was more realistically simulated than rudimentary rate control in NOE maneuvers where the latter suffered more from cue deficiencies.

Flight Directors; helped decelerating approaches but had no effect on constant speed approaches where judgment of closure rate is not as crucial. But this was true both in flight and simulation inferring that the visual Flight Director instrument cues, the same for both (simulation and flight) are dominant for the decelerating approaches and motion similitude is a secondary consideration.

Motion washout effects which because of phase distortion and resulting frequency-dependent visual cue conflict can force the simulator pilot to higher bandwidth (where the conflict is minimized) than in flight for similar ratings.

Visual Texture, resolution, and FOV deficiencies which increase the difficulty of judging translation and attitude displacement and rate in the simulator. Notice in this respect that a conventional flared landing must be classified as an aggressive maneuver.

For the non-aggressive tracking-type tasks presented:

Angular motion allows realistic generation of inner attitude loop pilot lead if needed to equalize the effective vehicle.

For tasks involving large bank angle motion, the washed-out lateral (sway) motion needed to counter the "uncoordinated" roll gravity component was regarded unfavorably by the pilots when peak lateral accelerations were greater than about 0.1 - 0.15 g. On the other hand, task performance was not much affected by a wide range of second-order wash-out characteristics which included peaks as high as 0.28 g.

For K/s-like vehicles (rate ordering), pilot lead generation is not required for proper crossover, and fixed-base simulation with careful attention to task details can be adequate. The studies of shuttle PIO and roll ratcheting are examples of such cases where by virtue of an "urgent" display and of precise pilot behavior measurements, respectively, results matching full-scale flight were obtained.

Fixed-base simulations can produce credible results also, when task emphasis is on path performance with or without side tasks such as situation assessment and judgment. This was the case for the carrier approach and drinking driver simulations, with overall results in both cases reflecting realistic accident trends.

Accumulated time delays from a variety of simulator component sources will cause reductions in the effective system bandwidth, relative to those in flight. If the bandwidth change occurs in a rating sensitive region, the simulator will be more poorly rated than flight for this reason alone. For regions of flat rating trend with bandwidth, excessive time delay and associated phase lag will still lead to anomalous simulation results.

In general, measurement of pilot behavior in flight and simulator, directly as by frequency domain or model matching methods, or indirectly as by phase-plane trajectories is an invaluable tool for judging overall simulator fidelity. Further, it can produce direct or inferred insights into specific causes of simulator difficulty and pinpoint possible fixes or cures.

VI. REFERENCES

1. Heffley, Robert K., Warren F. Clement, Robert F. Ringland, et al., Determination of Motion and Visual System Requirements for Flight Training Simulators, 1981, ARI-TR-546.
2. Key, David L., (Ed.), Fidelity of Simulation for Pilot Training, 1980, AGARD Advisory Report No. 159.
3. Sinacori, John B., Piloted Aircraft Simulation Concepts and Overview, 1978, NASA CR-152200.
4. Ad Hoc Advisory Subcommittee, Avionics, Control and Human Factors.
5. McRuer, Duane, Irving Ashkenas, and Dunstan Graham, Aircraft Dynamics and Automatic Control, Princeton, NJ, Princeton University Press, 1973.
6. Stapleford, Robert L., Richard A. Peters, and Fred R. Alex, Experiments and a Model for Pilot Dynamics With Visual and Motion Inputs, 1969, NASA CR-1325.
7. Jex, Henry R., Raymond E. Magdaleno, Wayne F. Jewell, et al., Effects on Target Tracking of Motion Simulator Drive-Logic Filters, 1981, AFAMRL-TR-80-134.
8. Jex, H. R., R. E. Magdaleno, and A. M. Junker, "Roll Tracking Effects of G-Vector Tilt and Various Types of Motion Washout," Fourteenth Annual Conference on Manual Control, NASA CP-2060, Nov. 1978, pp. 463-502.
9. Jex, Henry R., Wayne F. Jewell, and Raymond E. Magdaleno, "Effects of Various Lateral-Beam-Motion Washouts on Pilot Tracking and Opinion in the "LAMAR" Simulator," Proceedings of the Fifteenth Annual Conference on Manual Control, AFFDL-TR-79-3134, 1979, pp. 244-266.
10. Roark, Marvin, and Andrew Junker, "The Effects of Closed Loop Tracking on a Subjective Tilt Threshold in the Roll Axis," Proceedings of the Fourteenth Annual Conference on Manual Control, NASA CP-2060, Nov. 1978, pp. 443-450.
11. Jewell, Wayne F., Warren F. Clement, Lt. Col. Thomas C. West, USA (Ret.), et al., Powered-Lift Aircraft Handling Qualities in the Presence of Naturally-Occurring and Computer-Generated Atmospheric Disturbances, 1979, FAA-RD-79-59.
12. Gullen, Robert K., Charles S. Cattell, and Robert K. Overton, The Computer Image Generation: Applications Study, 1980, AFWAL-TR-80-3075.
13. Harker, George S., and Paul D. Jones, Depth Perception in Visual Stimulation, 1980, AFHRL-TR-80-19.
14. Sinacori, John B., Research and Analysis of Head-Directed Area-of-Interest Visual System Concepts, John B. Sinacori Associates, Circa 1982.
15. Noh, Roger H., Investigation of Outside Visual Cues Required for Low Speed and Hover, 1984, Systems Technology, Inc., TR-1213-1.
16. Staples, K. J., "Current Problems of Flight Simulators for Research," Aeronautical Journal, Vol. 805, 1978, pp. 12-32.

17. Hoh, Roger H., Samuel J. Craig, and Irving L. Ashkenas, Identification of Minimum Acceptable Characteristics for Manual STOL Flight Path Control. Volume III: Detailed Analyses and Tested Vehicle Characteristics, 1976, FAA-RD-75-123(III).
18. Baron, Sheldon, Ramal Muralidharan, and David Kleinman, "Closed Loop Models for Analyzing the Effects of Simulator Characteristics," AIAA Paper 78-1592, AIAA Flight Simulation Technologies Conference, Arlington, TX, 18-20 Sept. 1978, pp. 138-148.
19. Parrish, Russell V., Burnell T. McKissick, and Billy R. Ashworth, Comparison of Simulator Fidelity Model Predictions with In-Simulator Evaluation Data, 1983, NASA TP-2106.
20. Hess, Ronald A., "The Effects of Time Delays on Systems Subject to Manual Control," AIAA Paper 82-1523, AIAA Guidance and Control Conference Proceedings, San Diego, CA, 9-11 Aug. 1982, pp. 165-172.
21. Allen, R. Wade, and Richard J. DiMarco, Effects of Transport Delays on Manual Control System Performance, NASA CP-2341, Vol. I, Sept. 1984, pp. 185-201.
22. McRuer, Duane T., and Richard H. Klein, "Comparison of Human Driver Dynamics in an Automobile on the Road with Those in Simulators Having Complex and Simple Visual Displays," Systems Technology, Inc., P-173A, presented at the 55th Annual Meeting of the Transportation Research Board, Washington, D.C., 19-23 Jan. 1976.
23. Gum, D. R., and W. B. Albery, "Time-Delay Problems Encountered in Integrating the Advanced Simulator for Undergraduate Pilot Training," J. Aircraft, Vol. 14, No. 4, Apr. 1977, pp. 327-332.
24. Allen, R. Wade, and Henry R. Jex, "Driving Simulation -- Requirements Mechanization and Application," SAE Paper 800448, presented at the SAE Congress and Exposition, Detroit, MI, Feb. 1980; also SAE Trans., Vol. 89, 1981, pp. 1769-1780.
25. Howe, R. M., "Special Considerations in Real-Time Digital Simulation," The Proceedings of the 1983 Summer Computer Simulation Conference, Volume 1, 11-13 July 1983, Vancouver, B.C., Canada, pp. 66-71.
26. Whitbeck, Richard F., Elements of Simulation Error Analysis, 1982, AFWAL-TR-82-3022.
27. McDonnell, John D., Pilot Rating Techniques for the Estimation and Evaluation of Handling Qualities, 1968, AFFDL-TR-68-76.
28. Clement, Warren F., Roger H. Hoh, Samuel W. Ferguson, et al., Flying and Ground Handling Qualities Requirements for Military Rotorcraft -- MIL-H-8501 Revised, 1984, Systems Technology, Inc., TR-1194-1-I.
Clement, Warren F., Roger H. Hoh, David G. Mitchell, et al., Background and Rationale for Revised Military Rotorcraft Flying Qualities Specification, 1984, Systems Technology, Inc., TR-1194-1-II.
29. Jewell, Wayne F., "Summary of Daily Activities for the SH-60B Study on the Vertical Motion Simulator," Systems Technology, Inc., WP-1198-6, July 1984.
30. Hanson, Gregory D., and Wayne F. Jewell, Non-Intrusive Parameter Identification Procedure User's Guide, 1983, NASA CR-170398.
31. Clement, Warren F., William B. Cleveland, and David L. Key, "Assessment of Simulation Fidelity Using Measurements of Piloting Techniques in Flight," presented as Paper No. 55 at the AGARD G&C Panel 38th Symp., Helicopter Guidance & Control Systems for Battlefield Support, U.S. NPS, Monterey, CA, 8-11 May 1984; also AHS Paper No. A-84-40-08-4000, 16-18 May 1984.
32. Heffley, Robert K., "Pilot Models for Discrete Maneuvers," AIAA Paper No. 82-1519-CP, AIAA Guidance & Control Conf. Proc., San Diego, CA, Aug. 1982, pp. 132-142.
33. Truxal, John G., Automatic Feedback Control System Synthesis, New York, McGraw-Hill Book Company, Inc., 1955.
34. Flugge-Lotz, Irmgard, Discontinuous Automatic Control, Princeton, NJ, Princeton University Press, 1953.
35. Palmer, Everett, Tamara Mitchell, and John Pettit, Angular Size Estimation: A Measure of Simulator Visual Fidelity, (unpublished paper), no date, circa Jan. 1979.
36. Kibort, Bernard R., and Fred J. Drinkwater, III, A Flight Study of Manual Blind Landing Performance Using Closed Circuit Television Displays, 1964, NASA TN D-2252.

37. Ashkenas, I. L., and T. S. Durand, "Simulator and Analytical Studies of Fundamental Longitudinal Control Problems in Carrier Approach," AIAA Simulation for Aerospace Flight Conference, A Volume of Technical Papers, 26-28 Aug. 1983, Columbus, OH, pp. 16-34.
38. Jex, H. R., and C. H. Cromwell, III, Theoretical and Experimental Investigation of Some New Longitudinal Handling Qualities Parameters, 1982, ASD-TR-61-26.
39. Durand, Tulvio S., and Richard J. Wasicko, "Factors Influencing Glide Path Control in Carrier Landing," J. Aircraft, Vol. 4, No. 2, Mar.-Apr. 1967, pp. 146-158.
40. Ringland, R. F., and A. A. Blauvelt, Carrier Landing Aid Stabilization System (Final Report), 1971, Systems Technology, Inc. TR-186-1.
41. Allen, R. W., A. C. Stein, and J. R. Hogue, The Effects of Alcohol and Marijuana on Driver Control Behavior in a Driving Simulator, 1982, Systems Technology, Inc., TR-1066-1.
42. Ashkenas, Irving L., Roger H. Hoh, and Gary L. Teper, "Analyses of Shuttle Orbiter Approach and Landing," J. of Guidance, Control and Dynamics, Vol. 6, No. 6, Nov.-Dec. 1983, pp. 448-455.
43. Johnston, Donald E., and Duane T. McRuer, "Investigation of Limb Sidestick Dynamic Interaction with Roll Control," AIAA Paper 85-1853-CP, to be presented at the AIAA 12th Atmospheric Flight Mechanics Conference, Snowmass, CO, 19-21 Aug. 1985.
44. Garland, Michael P., Michael K. Nelson, and Richard C. Patterson, F-16 Flying Qualities With External Stores, 1981, AFFTC-TR-80-29.
45. Hall, G. Warren, and Rogers E. Smith, Flight Investigation of Fighter Side-Stick Force-Deflection Characteristics, 1975, AFFDL-TR-75-39.
46. McRuer, D. T., and E. S. Krendel, Mathematical Models of Human Pilot Behavior, 1974, AGARDograph No. 188.
47. Monagan, Stephen J., Rogers E. Smith, and Randall E. Bailey, Lateral Flying Qualities of Highly Augmented Fighter Aircraft, 1982, AFWAL-TR-81-3171.
48. "Development of Mission Oriented Handling Qualities Requirements for Military Rotorcraft," Contract NAS2-11304, Aug. 1982.
49. Clement, Warren F., Roger H. Hoh, David G. Mitchell, et al., Specification and Background Information and User's Guide (BIUG) for Flying and Ground Handling Qualities of the LHX, Systems Technology, Inc., TR-1194-2, Installment for IPR-6, 29 May 1985.
50. Ferguson, Samuel W., and Warren F. Clement, Assessment of Simulation Fidelity Using Measurements of Piloting Technique In Flight, 1984, Systems Technology, Inc., TR-1184-1.
51. Churchill, Gary B., and Ronald M. Gerdes, "Advanced AFCS Developments on the XV-15 Tilt Rotor Research Aircraft," AHS Paper No. A-84-40-10-4000, May 1984.
52. Scheuren, W. J., and J. L. Dunn, Flying Qualities and Performance Trials of the Model AV-8A Airplane, 1971, NATC Report No. FT-27R-71.
53. Stapleford, Robert L., Warren F. Clement, Robert K. Heffley, et al., Flight Control/Flying Qualities Investigation for Lift/Cruise Fan V/STOL. Volume II: Piloted Simulation, 1979, NADC-77143-30.
54. Landis, Kenneth H., and Steven L. Glusman, Development of ADOCS Controllers and Control Laws. Final Report -- Volume 3: Simulation Results and Recommendations, 1984, Boeing Vertol Report B210-12323-3.
55. Farris, G. G., V. K. Merrick, and R. M. Gerdes, "Simulation of Flight Controls and Display Concepts for VTOL Shipboard Approaches," AIAA Paper No. 83-2173CP, Aug. 1973.
56. Hoh, Roger H., David G. Mitchell, and John Hodgkinson, "Bandwidth -- A Criterion for Highly Augmented Airplanes," Criteria for Handling Qualities of Military Aircraft, AGARD CP-333, June 1982, pp. 9-1 -- 9-11.
57. Hoh, Roger H., and David G. Mitchell, Proposed Revisions of MIL-F-8330, V/STOL Flying Qualities Specification, 1985, Systems Technology, Inc., TR-1196-1.
58. Lebacqz, J. V., R. D. Forrest, and R. M. Gerdes, A Piloted Simulator Investigation of Static Stability and Stability/Control Augmentation Effects on Helicopter Handling Qualities for Instrument Approach, 1980, NASA TM-81188.

59. Lebacqz, J. V., J. M. Weber, and L. D. Corliss, "A Flight Investigation of Static Stability, Control Augmentation, and Flight Director Influence on Helicopter IFR Handling Qualities," AHS Preprint No. 81-25, May 1981.
60. Lebacqz, J. V., R. D. Forrest, and R. M. Gerdes, A Ground-Simulator Investigation of Helicopter Longitudinal Flying Qualities for Instrument Approach, 1982, NASA TM-84225.
61. Lebacqz, J. V., R. D. Forrest, and R. M. Gerdes, A Piloted Simulator Investigation of Stability and Control, Display, and Crew-Loading Requirements for Helicopter Instrument Approach. Part I -- Technical Discussion and Results, 1982, NASA TM-84258.
62. Phatak, Anil K., Lewis L. Peach, Ronald A. Hess, et al., "A Piloted Simulator Investigation of Helicopter Precision Decelerating Approaches to Hover to Determine Single-Pilot IFR (SPIFR) Requirements," AIAA Paper No. 79-1886, Aug. 1979.
63. NRC of Canada Flight Test Results, Unpublished.
64. Hoh, R. H., D. G. Mitchell, et al., Proposed MIL Standard and Handbook -- Flying Qualities of Air Vehicles, Vol. II: Proposed MIL Handbook, AFWAL-TR-82-8301, Nov. 1982.

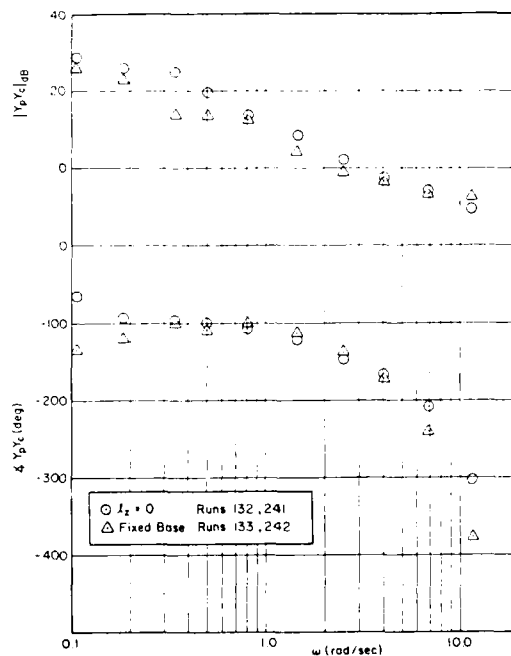

Figure 1. Motion Effects for $Y_c = Y_c/s(s + 10)$ (Ref. 6)

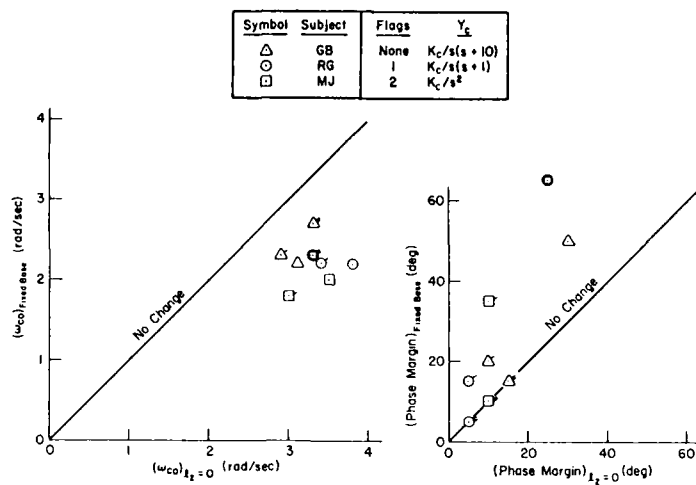
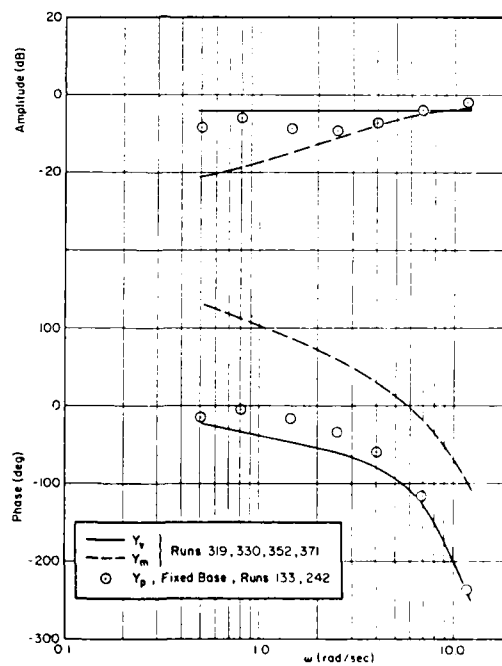

Figure 2. Motion Effects on Crossover Frequency and Phase Margin (Ref. 6)

Figure 3. Visual and Motion Feedbacks for $Y_c = K_c/s(s+10)$, $l_z = 0$ (Ref. 6)

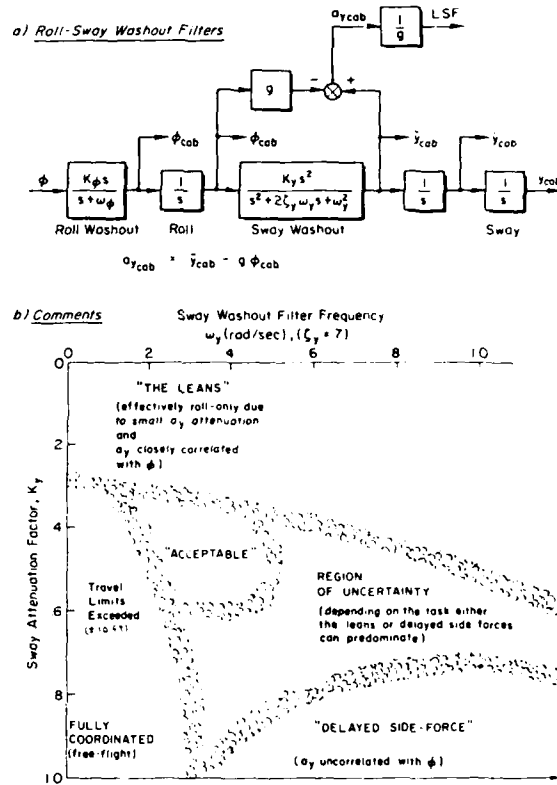

Figure 4. Boundaries of Sway-Axis Washout Filter Parameters Which Delineate the Pilots' Impressions of Realism From Combined Roll and Sway Motion Cues (Ref. 9)

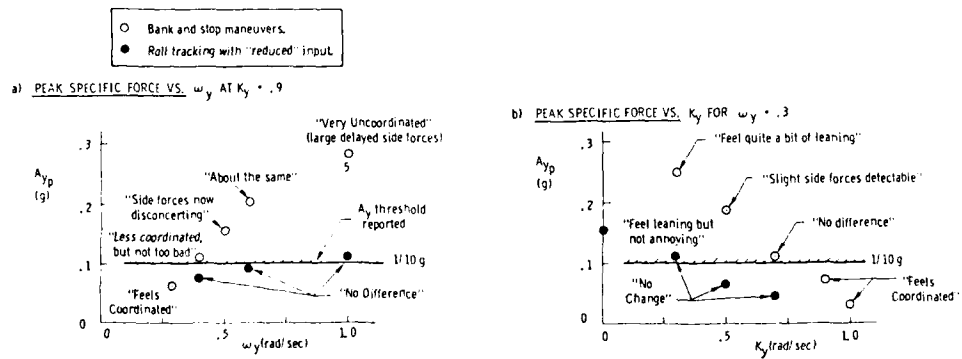

Figure 5. Summary of Pilot Commentary for Bank and Stop Maneuvers and Roll Tracking (Ref. 9)

FIELD OF VIEW

Upper Front	Narrow	Nominal	Nominal	Nominal	Nominal	Wide	Wide
Lower Front	Closed	Closed	Nominal	Closed	Closed	Closed	Nominal
Right Side	Closed	Closed	Closed	Nominal	Nominal	Nominal	Nominal
Left Side	Closed	Closed	Closed	Nominal	Nominal	Nominal	Nominal

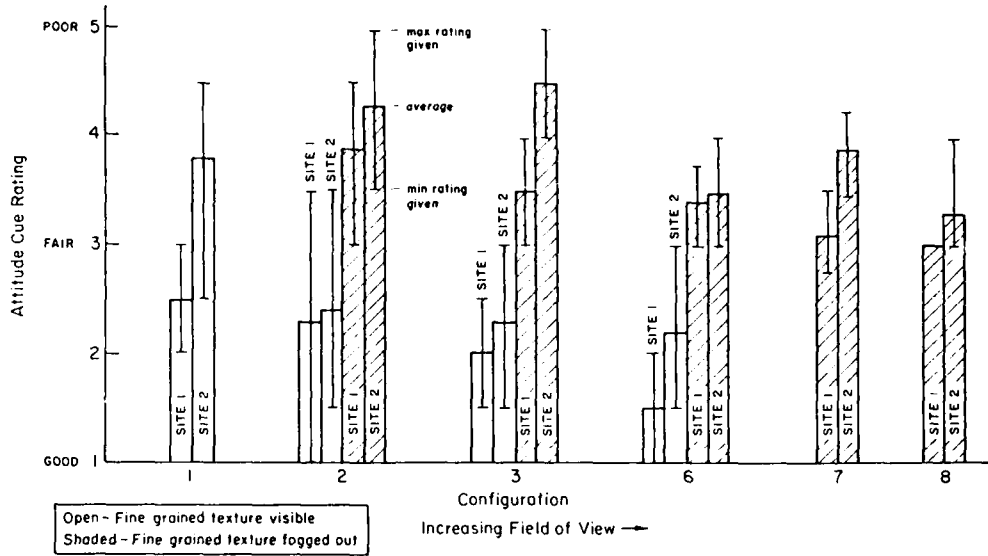

Figure 6. Attitude Cue Pilot Ratings (Ref. 15)

FIELD OF VIEW

Upper Front	Narrow	Nominal	Nominal	Nominal	Wide	Wide
Lower Front	Closed	Closed	Nominal	Closed	Closed	Nominal
Right Side	Closed	Closed	Closed	Nominal	Nominal	Nominal
Left Side	Closed	Closed	Closed	Nominal	Nominal	Nominal

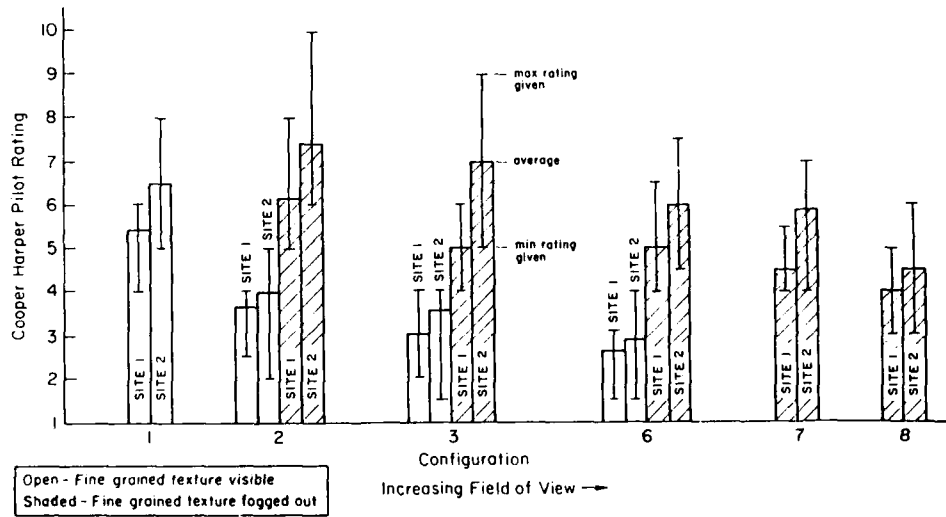

Figure 7. Cooper-Harper Pilot Ratings (Ref. 15)

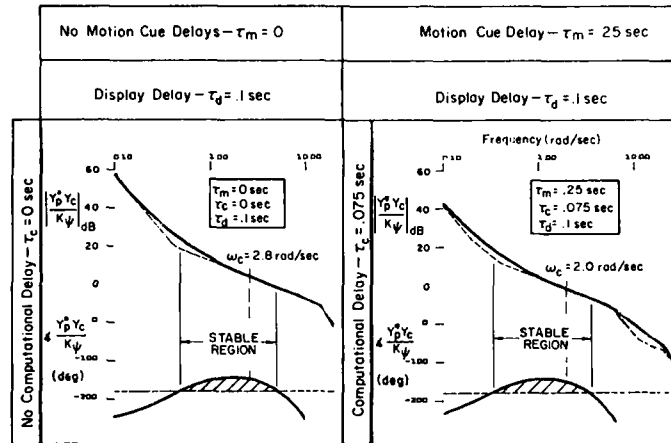

Figure 12. Equivalent Open-Loop Human Operator/Vehicle Describing Functions for Example Levels of Simulation Time Delays (Ref. 21)

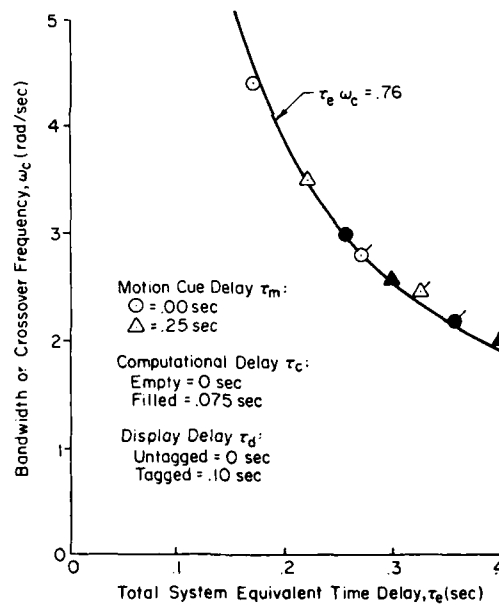

Figure 13. System Bandwidth as a Function of System Time Delay (Ref. 21)

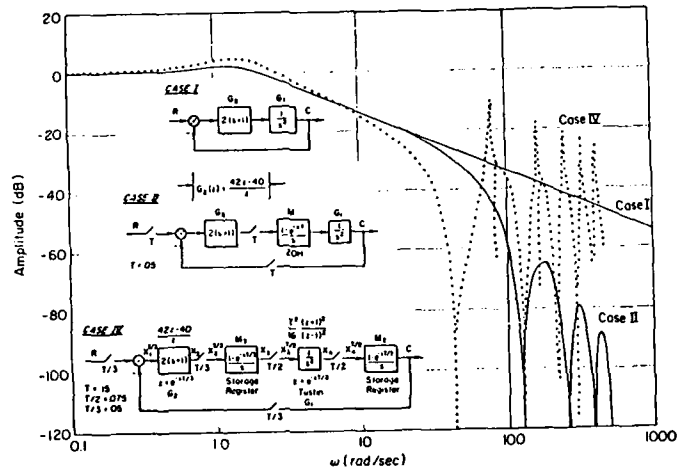

Figure 14. Comparison, Case II and Case IV (Ref. 26)

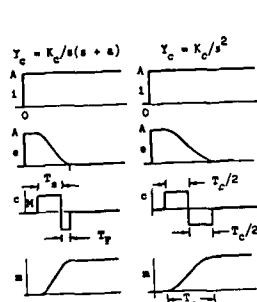

Figure 15. Ideal Time-Optimal Response Characteristics (T_c is the time to complete the control program)

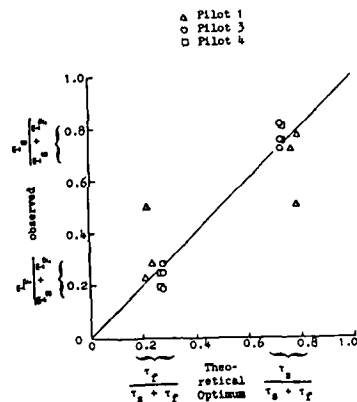

Figure 16. Control Pulse Intervals During the Rapid Response Interval in Bob-Up Maneuvers in Flight (Ref. 31)

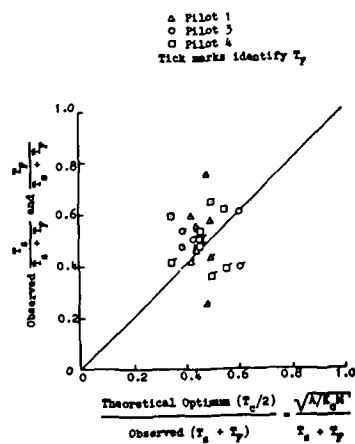

Figure 17. Control Pulse Intervals During the Rapid Response Interval in Bob-Up Maneuvers in the Simulator (Ref. 31)

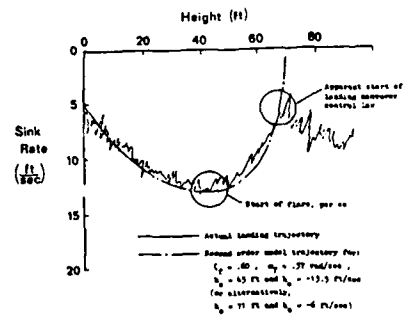

Figure 18. Typical Landing Maneuver Performed in the Actual Aircraft (Ref. 32)

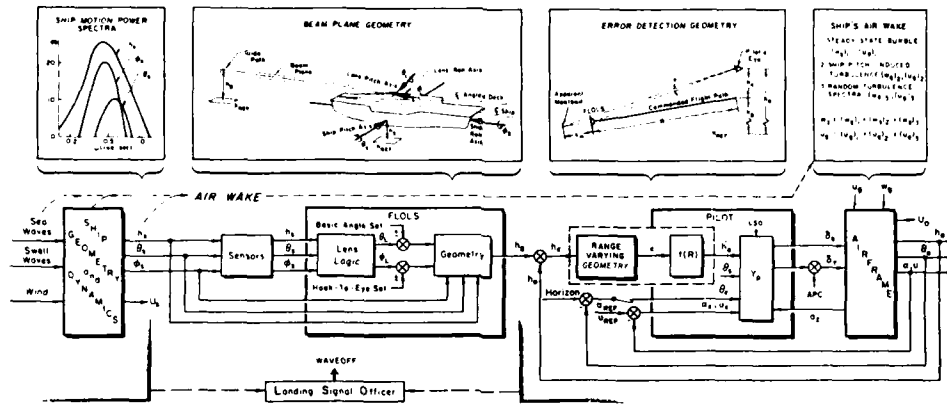
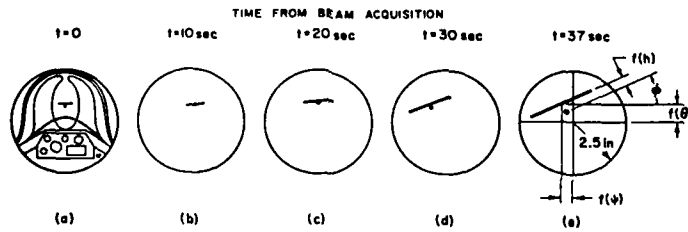

Figure 19. Major Elements of the Landing System (Ref. 39)



DISPLAY SCALING OF (CRT) ATTITUDE AND FLIGHT PATH MOTIONS

MOTION QUANTITY	REPRESENTATION ON CRT	CRT SCALE
Pitch attitude error, θ_g	Up-down translation of mastball and datum bar	0.125 in./deg
Flight path deviation, h_g	Mastball deviation from datum bar, inversely proportional to range squared	$3000/R^2(t)$, in./ft $R(t) = 5000$ to 450 ft
Bank angle, ϕ_g	Rotation of datum bar	1 deg/deg
Heading error, ψ_g	Left-right translation of mastball and datum bar	0.125 in./deg
Range, t	Length of datum bar inversely proportional to range	$1000/R(t)$, in. $R(t) = 5000$ to 450 ft

Figure 20. Cathode Ray Tube Display of Aircraft Motions (Ref. 37)

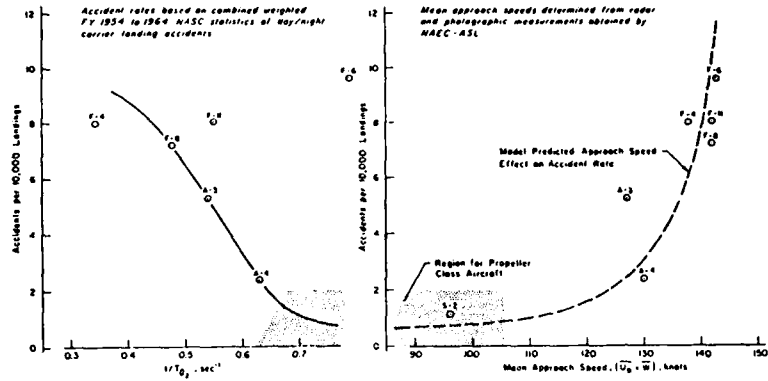

Figure 21. Implied Bivariate Dependency of Accident Rate on $1/T_{\theta_2}$ and Approach Speed (Ref. 39)

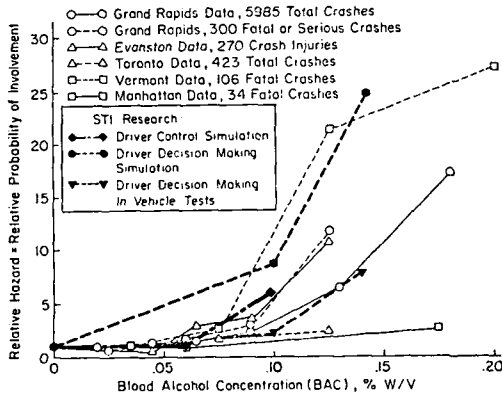

Figure 22. Relative Probability of Crash Involvement as a Function of BAC Where 1.0 = Relative Probability at Zero Alcohol. Comparison of Real World Data, Current STI Driver Control Study, and Past STI Driver Decision Making Studies (Ref. 41)

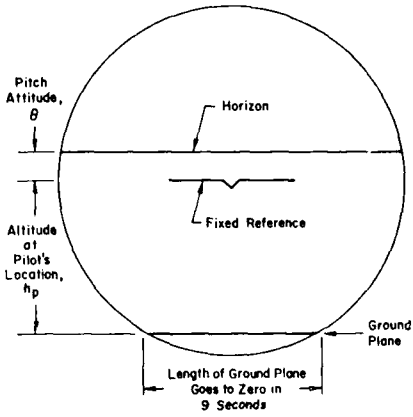

Figure 23. Simulation Display (Ref. 42)

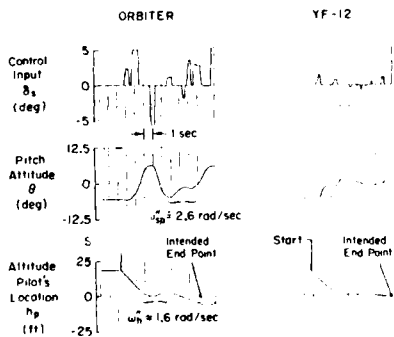

Figure 24. Comparison of Orbiter and YF-12 Simulation Responses (Ref. 42)

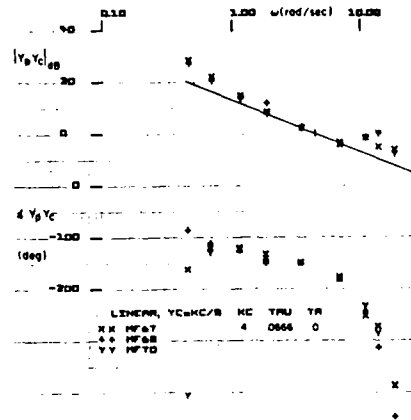

Figure 25. Y_p/Y_c Describing Function Amplitude and Phase Plot for $Y_c = 4/s e^{-0.067s}$ (Ref. 43)

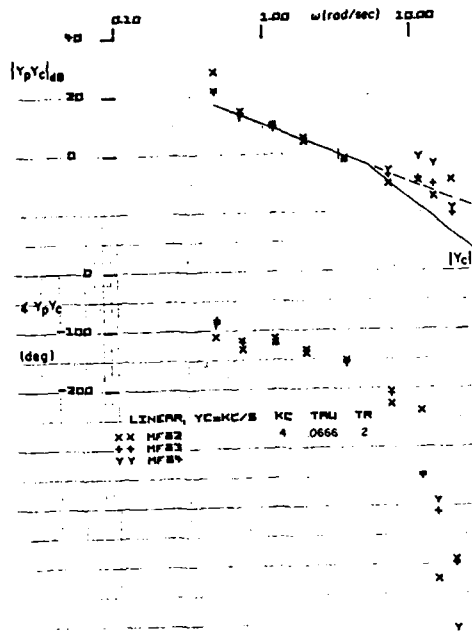

Figure 26. Y_p/Y_c Describing Function Amplitude and Phase Plot for $Y_c = \frac{4e^{-0.067s}}{s(0.2s+1)}$ (Ref. 43)

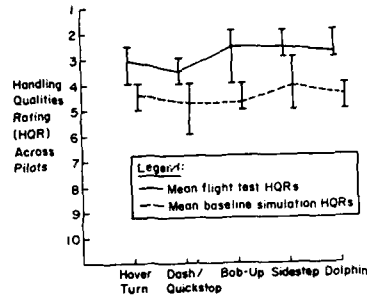

Figure 28. Ranges for Pilot Handling Qualities Rating as a Function of Task for the Flight Test and the Baseline Simulation (Ref. 31)

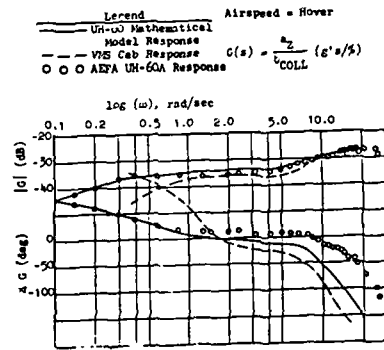

Figure 29. UH-60A Rotorcraft and Simulator Frequency Responses for the Transfer Function a_z/s_{COLL} at Hover (Ref. 31)

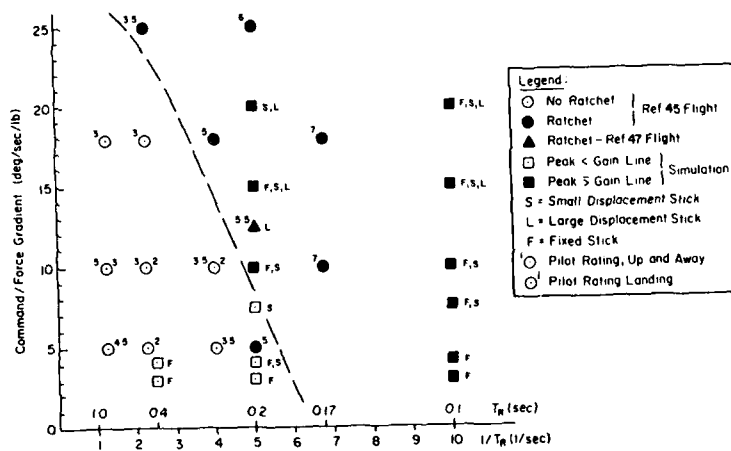

Figure 27. Roll Ratchet Comparison, Flight and Simulator (Ref. 43)

Sym	Ref	Response Type	Aircraft (flight/sim)	Task(s)	ω_{wg}	Turbul
○	50	Rate	UH-60A (VMS)	Sidestep	2.3	Light
●	50	Rate	UH-60A (flight)	Sidestep	2.1	Light
○	53	RCAH	V/STOL (FSAA)	Shipboard Ldg	2.3	Light
◇	54	RCAH	ADDCS (vertol sim)	NOE	2.6	None
△	54	RCAH	ADDCS (VMS)	NOE	2.8	None
◇	54	RCAH	ADDCS (VMS)	Precision Hover	2.8	Mod
●	51	RCAH	XV-15 (flight)	Hover Transl	2.9	Light
●	51	Rate (SAS off)	XV-15 (flight)	Hover Transl	0.4	Light
■	52	Rate	AV-8A (flight)	Hover (day)	2.3 (est)	Light
◇	55	Rate	V/STOL (VMS)	Shipboard Ldg	1.8	Light

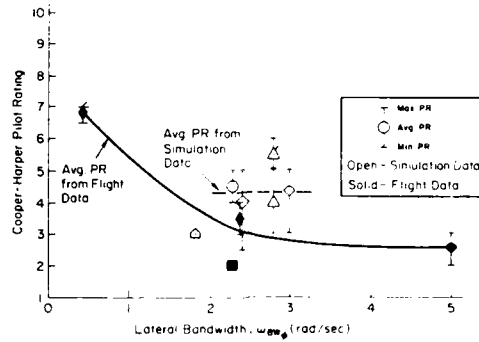

Figure 30. Comparison of Flight and Simulation Results for Rate Response-Types (including RCAH) (Ref. 49)

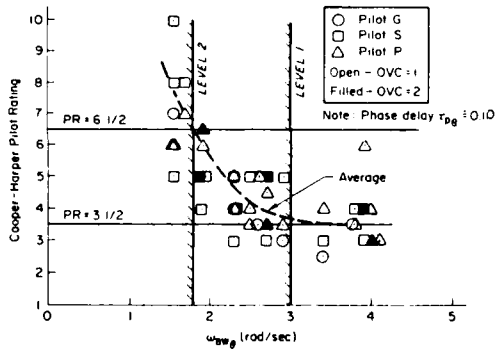

Figure 31. Pilot Rating vs. Pitch Attitude Bandwidth for ACAH Cases, Vertical Landing Task. Note: $\omega_{wg} \approx \omega_{\psi}$; $\tau_p \approx \tau_{\dot{\psi}}$ (Ref. 57)

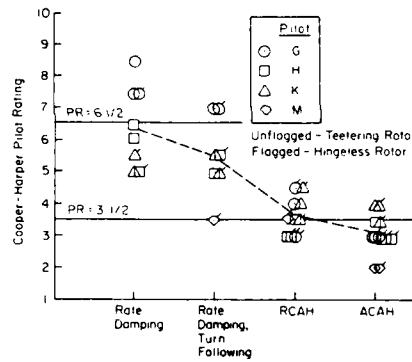

Figure 32. Pilot Ratings from Piloted Simulation (VMS). Light Turbulence, No Flight Director (Ref. 58)

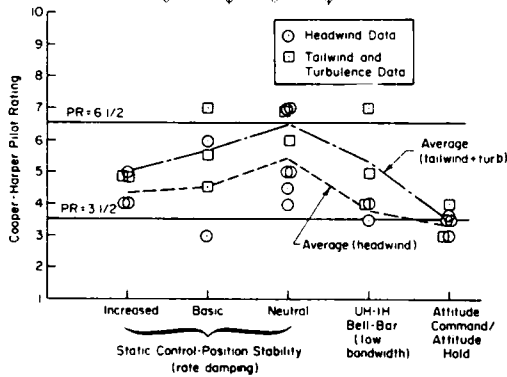

Figure 33. Pilot Ratings from Flight Tests. No Flight Director (Ref. 59)

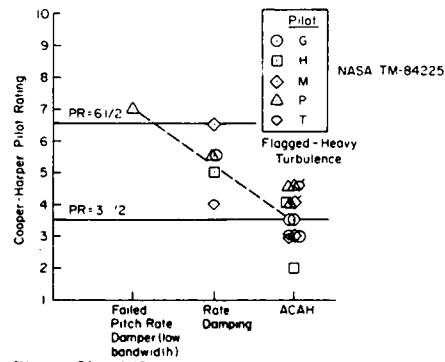

Figure 34. Pilot Rating Results from Piloted Simulation of $M = 0$, Most Neutral Stick Position Gradient (Except ACAH). RCAH in Roll. Light/Moderate Turbulence, No Flight Director (Ref. 60)

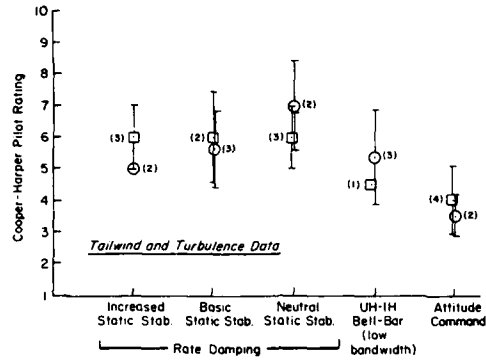

Figure 35. Effect of Three-Que Flight Director on Pilot Ratings for Constant-Speed MLS Approach (UH-1H Flight Data) (Ref. 59)

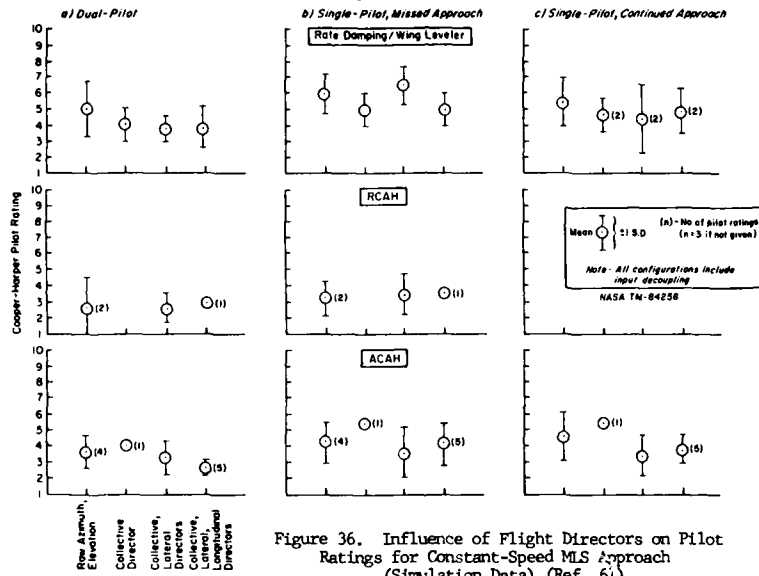

Figure 36. Influence of Flight Directors on Pilot Ratings for Constant-Speed MLS Approach (Simulation Data) (Ref. 61)

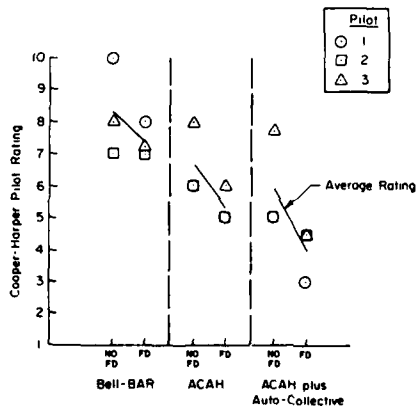

Figure 37. Pilot Ratings for Decelerating Approach (0.045g + 0.035g from Simulation) (Ref. 62)

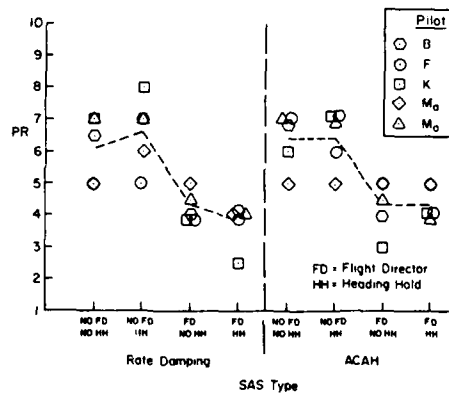

Figure 38. Pilot Ratings from NAE Flight Tests with Bell 205A; Deceleration Rate of 0.1g at Start, Constant-Attitude (Ref. 63)

TABLE 1. STI EXPERIENCE WITH VARIOUS SIMULATORS

Legend for STI participation: None, * Minor, ** Major, All

CONTRACT	WORKSITE	NATURE OF RESEARCH	STI PARTICIPATION IN						PERTINENT REPORTS
			SYSTEM DESIGN	EQUIPMENT	MAN-DRIVEN	FORMAL TRAINING	DATA ANAL.	REPORT	
N62269-82-C-0728	NASA Ames VMS	Helicopter handling for shipboard operations	ALL	**	ALL	ALL	ALL	ALL	STI TR-1188-1 (forthcoming)
N62269-77-C-0275	NASA Ames VMS	Reassessed V/STOL Flying Qualities Spec, MIL-F-83100	ALL	**	ALL	ALL	ALL	ALL	STI TR-1196-1
NAS2-11317	NASA Ames V/STOL FSAA	Reformat existing XV-15 model to provide generic tilt rotor capability	ALL	**	ALL	ALL	ALL	ALL	NASA CR-166535 NASA CR-166536
NAS2-11098	NASA Ames VMS	Evaluate fidelity of DR-80 simulation	**	*	**	**	**	**	STI TR-1184-1
NAS2-10120 NAS2-10385	NASA Ames Research Center, STOLAND Simulator	CTOL techniques in terminal operations with wind shear	*	**	*	*	**	**	NASA CR-152294
N62269-78-C-0129	NASA Ames Research Center FSAA with HUD provided by FSDS	Comparative eval of V/STOL approach and landing on moving ship with different CAS and visibility	ALL	*	**	**	ALL	ALL	NADC-77143-30
F33615-77-C-2065	Vought Large Amplitude Motion Simulator (LAMBS), 5 DOF, Recv made for LAMARS	Motion cue requirements and practical modifications to motion software/hardware	ALL	*	**	**	**	ALL	AFDOL-TR-78-192
DOT-FA77MA-3936	NAE Airborne V/STOL Simulator, NASA/ANG FSAA	Simulator studies of STOL handling in steep descent	*	**	*	**	**	**	FAA-RD-78-59
NAS2-9418	NASA Ames, STOLAND Simulator, Fixed Base	Controllability, display design alternatives	ALL	**	ALL	ALL	ALL	ALL	NASA CR-152138
F33615-77-C-0508	UPAFB: AFAPML DES, 6 DOF, AFFDL LAMARS, 6 DOF	Evaluate roll and sway washouts	ALL	**	ALL	ALL	ALL	ALL	AFAPML-TR-80-134
NAS2-9192	NASA Ames Research Center STOLAND 6 DOF fixed base	Eval approach precision tracking and end lg control	**	*	**	**	**	**	NASA CR-152040
N00019-76-C-0636	McDonnell Aircraft 5 DOF motion base	F-18A carrier approach model assessment	**	**	**	*	**	**	STI TR-1090-1
F33615-76-C-3072	Grumman analog and MACDAC hybrid 6 DOF aircraft-air tracking facilities	Evaluate departure and recovery from controlled flight	ALL	*	**	**	ALL	ALL	AFMIL-TR-80-3141
NAS2-8973	NASA Ames Research Center, STOLAND Simulator	Comparison of HUD and HSI in different ATC situations	ALL	**	**	**	**	**	NASA CR-137922
NAS2-8889	NASA Ames Research Center, FSAA, 6 DOF, and Sigma 7	Powered-lift aircraft in severe wind shears	ALL	**	**	**	ALL	ALL	NASA CR's-152064, 152135, 152470
NAS2-8731	NASA Ames Research Center, FSAA, 6 DOF	Landing performance of DLC, flight directors, and HUD	ALL	**	**	**	ALL	ALL	STI TR-1059-1
NAS2-8025	NASA Ames Research Center, FSAA, 6 DOF	Fidelity of visual motion for tilt rotor simulation	*	**	*	*	*	*	STI TR-1048-1
NAS2-7926	NASA Ames Research Center, FSAA, 6 DOF	Study of STOL transport in terminal area flight regime	ALL	**	*	**	**	**	NASA TR-82395, 82396
DOT-FA77MA-3276	NASA Ames Research Center, S-16, 3 DOF, FSAA, 6 DOF	STOL transport longitudinal flight path control study	ALL	**	**	ALL	ALL	ALL	STI TR-1035-2
F33615-73-C-3101	LSI Simulator, Fixed Base	Handling in stall-departure flight regimes	ALL	**	ALL	ALL	ALL	ALL	AFDOL-TR-74-61
NAS-1962 (DOT-FA77MA-3276)	NASA Ames Research Center, FSAA, 6 DOF, 17	Heard boundaries for penetration of wake vortices	ALL	**	**	**	ALL	ALL	FAA-RD-76-8
NAS2-6441	NASA Ames Research Center, FSAA, 6 DOF	Flight director and configuration management for VASA augmentor wing	**	**	**	**	**	**	NASA CR's-114697, 114698, 114688, 2883
NAS2-6433	NASA Ames Research Center, S-16, 3 DOF	Motion cue effects in STIL approach and landing	ALL	**	ALL	ALL	ALL	ALL	NASA CR-114438 NASA TR X-62,392, X-62,393, X-62,394
NASW-2115	NASA Ames Research Center, S-16, 3 DOF	Flight director, autopilot for turbulence penetration	**	*	**	**	**	**	STI TR-1003-1
NAS2-6075	NASA Ames Research Center, S-16, 3 DOF Radion display	Space shuttle handling qualities	ALL	**	**	**	ALL	ALL	NASA CR-2017
TM 1-1335 from NMC, FAA	NASA Ames Research Center, S-16, 3 DOF Radion display	Handling quality criteria (commercial) STOL	**	*	**	**	**	**	STI TR-2001-1
UCLA Agreement 010021, 010022	UCLA Driving Simulator	Fliggyback experiment on driver's response	**	*	**	**	ALL	**	UCLA ETTE 70-73
NAS2-4405	NASA Ames Research Center, 5 DOF Centrifuge	Build MR Critical Task Tester, assist with analysis	*	*	**	**	*	*	1968 Aerospace Medicine Symp.
NAS2-1746 NAS2-5690	NASA Ames Research Center, MIB Landing Simulator	Multitask pilot dynamics, and scanning during IPR approach	ALL	*	**	ALL	ALL	ALL	NASA CR-1535, 1569, 1042
NAS2-3630 NAS2-5261	NASA Ames Research Center, 6 DOF Motion Simulator	Pilot response/scanning while hovering with motion	ALL	*	**	**	**	ALL	NASA CR-1325 NASA CR-1933
Nonr-4136(001)	Naval Air Test Center Patuxent River, MD	Pilot/aircraft dynamics during carrier landings	ALL	**	ALL	ALL	ALL	ALL	STI TR-137-6
AF 33(615)-2826	USAF Research Pilot School, Edwards AFB, CA	Drug, workload effects on tracking, and critic instab	**	**	*	**	ALL	ALL	AMRL-TR-67-94

TABLE 2. FIELD-OF-VIEW CONFIGURATIONS

LOCATION	CONFIGURATION							
	1	2	3	4	c	6	7	8
Upper Front	narrow	nom	nom	nom	nom	nom	wide	wide
Lower Front	c	c	nom	nom	nom	c	c	nom
Right Side (door)	c	c	c	nom	nom	nom	nom	nom
Left Side (center)	c	c	c	c	nom	nom	nom	nom

where "c" denotes that this area is covered.

TABLE 3. RATING SCALE FOR SIMULATOR VALIDITY (REF. 29)

CATEGORY	RATING	ADJECTIVE	DESCRIPTION
Satisfactory representation of actual vehicle	1	Excellent	Virtually no discrepancies; simulator reproduces actual vehicle characteristics to the best of my memory. Simulator results directly applicable to actual vehicle with high degree of confidence.
	2	Good	Very minor discrepancies. The simulator comes close to duplicating actual vehicle characteristics. Simulator results in most areas would be applicable to actual vehicle with confidence.
	3	Fair	Simulator is representative of actual vehicle. Some minor discrepancies are noticeable, but not distracting enough to mask primary characteristics. Simulator trends could be applied to actual vehicle.
Unsatisfactory representation of actual vehicle	4	Fair	Simulator needs work. It has many minor discrepancies which are annoying. Simulator would need some improvement before applying results directly to actual vehicle, but is useful for general handling-qualities investigations for this class of aircraft.
	5	Bad	Simulator not representative. Discrepancies exist which prevent actual vehicle characteristics from being recognized. Results obtained here should be considered as unreliable.
	6	Very bad	Possible simulator malfunction. Wrong sign, inoperative controls, other gross discrepancies prevent comparison from even being attempted. No data.

TABLE 4. OBSERVED PILOTING CHARACTERISTICS IN BOB-UPS DURING THE ERROR REDUCTION PHASE (REF. 31)

CHARACTERISTICS	IN FLIGHT	IN SIMULATOR
Gain Crossover Frequency	0.7 to 1.1 rad/sec	0.5 to 1.3 rad/sec
First-Order Lead Equalization Frequency	0.3 to 1 rad/sec	0.2 to 0.4 rad/sec
Effective Time Delay	0.2 to 0.3 sec	0.44 to 0.6 sec
Closed-Loop Damping Ratio	0.3 to 0.8	0.1 to 0.4
Roll PIOs	None	~ 1.4 rad/sec in half of the bob-ups
Overshoots	< 1.5 m	3 to 6 m

TABLE 5. PILOT MODELING RESULTS FOR THE ERROR REDUCTION PHASE OF THE HOVER TURN (REF. 31)

PARAMETER	PILOT 1	PILOT 2	PILOT 3	PILOT 4
<u>Flight</u>				
Crossover Frequency (ω_c)				
Mean	0.6	0.55	0.5	0.6
Std. dev.	0.15	0.2	0.15	0.2
Closed-Loop Damping Ratio (ζ)				
Mean	0.15	0.2	0.45	0.35
Std. dev.	0.1	0.2	0.2	0.15
<u>Simulator</u>				
Crossover Frequency (ω_c)				
Mean	1.3	1.3	1.5	1.5
Std. dev.	0.25	0.25	0.35	0.35
Closed-Loop Damping Ratio (ζ)				
Mean	0.05	0.05	0.15	0.1
Std. dev.	0.05	0.1	0.15	0.15

TABLE 6. AVERAGE PILOT BEHAVIOR IN FLIGHT AND IN THE SIMULATOR (REF. 32)

FEATURES OF MANEUVER AND PILOT BEHAVIOR	PARAMETERS	ALL FLIGHT-TRAINED PILOTS IN FLIGHT	ALL PILOTS IN FLIGHT	ALL PILOTS IN THE SIMULATOR	REMARKS
Control of touchdown sink rate	ζ_{FL}	0.68	0.67	<u>0.58</u>	Harder landings in the simulator
	$\dot{h}_{TD}/\dot{h}_{max}$	0.25	0.27	<u>0.42</u>	
Abruptness of flare maneuver	ω_{FL} (rad/sec)	0.40	0.37	0.36	No difference
	ω_{ch} (rad/sec)	0.27	0.25	0.27	
Height feedback	ω_{FL}^2 (rad ² /sec ²)	0.17	0.13	0.15	No difference
	k_h (d: ;/ft)	0.11	0.08	0.10	
Direction-of-flight or sink rate feedback	$\zeta_{FL}\omega_{FL}$ (rad/sec)	0.28	0.25	0.20	Direction-of-flight loop lacking in the simulator
	k_γ (deg/deg)	0.40	0.25	<u>0</u>	

32 pilots 13 flight-trained, remainder simulator-trained

TABLE 7. SUMMARY OF IN-FLIGHT HELICOPTER SPEED CHANGE CHARACTERISTICS (REF. 32)

MANEUVER	LOOP-STRUCTURE, PILOT CUES	EFFECTIVE CROSSOVER FREQUENCY IN OUTER LOOP	IMPLIED BANDWIDTH REQUIREMENT FOR PITCH ATTITUDE
Normal Speed Change	$U + \theta_c$ (Integral-Plus-Proportional Compensation)	0.1 rad/sec	0.3 rad/sec
Decelerating Approach to Hover	$R_p + \theta_c$ (Pure Gain Using "Perceived Range")	Increasing to 0.3 rad/sec	Increasing to 1.0 rad/sec
NOE Dash/Quickstop	$R, \dot{R} + \theta_c$	0.8 rad/sec	2.5 rad/sec

REPORT DOCUMENTATION PAGE									
1. Recipient's Reference	2. Originator's Reference	3. Further Reference	4. Security Classification of Document						
	AGARD-CP-408	ISBN 92-835-0394-5	UNCLASSIFIED						
5. Originator	Advisory Group for Aerospace Research and Development North Atlantic Treaty Organization 7 rue Ancelle, 92200 Neuilly sur Seine, France								
6. Title	FLIGHT SIMULATION								
7. Presented at	the Flight Mechanics Panel Symposium held in Cambridge, United Kingdom, 30 September to 3 October 1985.								
8. Author(s)/Editor(s)	Various	9. Date	September 1986						
10. Author's/Editor's Address	Various	11. Pages	372						
12. Distribution Statement	This document is distributed in accordance with AGARD policies and regulations, which are outlined on the Outside Back Covers of all AGARD publications.								
13. Keywords/Descriptors	<table> <tr> <td>Flight simulators</td> <td>Pilot training</td> </tr> <tr> <td>Flight simulation</td> <td>Training simulators</td> </tr> <tr> <td>Control simulation</td> <td></td> </tr> </table>			Flight simulators	Pilot training	Flight simulation	Training simulators	Control simulation	
Flight simulators	Pilot training								
Flight simulation	Training simulators								
Control simulation									
14. Abstract	<p>In recent years, important advances have been made in technology for both ground-based and in-flight simulators. There has equally been a broadening of the use of flight simulators for research, development and training purposes.</p> <p>The objectives of this AGARD Flight Mechanics Panel Symposium were to provide an up-to-date description of the state-of-the-art of technology and engineering for both ground-based and in-flight simulators and to place into context their respective roles within the aerospace scene. All papers were obtained by invitation.</p> <p>These Conference Proceedings, commissioned by the AGARD Flight Mechanics Panel contain a Technical Evaluation Report which is also available separately as an Executive Summary as AGARD AR 234.</p>								

<p>AGARD Conference Proceedings No.408 Advisory Group for Aerospace Research and Development, NATO FLIGHT SIMULATION Published September 1986 372 pages</p> <p>In recent years, important advances have been made in technology for both ground-based and in-flight simulators. There has equally been a broadening of the use of flight simulators for research, development and training purposes.</p> <p>The objectives of this AGARD Flight Mechanics Panel Symposium were to provide an up-to-date description of the state-of-the-art of technology and engineering for both</p> <p>P.T.O</p>	<p>AGARD-CP-408</p> <p>Flight simulators Flight simulation Control simulation Pilot training Training simulators</p>	<p>AGARD Conference Proceedings No.408 Advisory Group for Aerospace Research and Development, NATO FLIGHT SIMULATION Published September 1986 372 pages</p> <p>In recent years, important advances have been made in technology for both ground-based and in-flight simulators. There has equally been a broadening of the use of flight simulators for research, development and training purposes.</p> <p>The objectives of this AGARD Flight Mechanics Panel Symposium were to provide an up-to-date description of the state-of-the-art of technology and engineering for both</p> <p>P.T.O</p>	<p>AGARD-CP-408</p> <p>Flight simulators Flight simulation Control simulation Pilot training Training simulators</p>
<p>AGARD Conference Proceedings No.408 Advisory Group for Aerospace Research and Development, NATO FLIGHT SIMULATION Published September 1986 372 pages</p> <p>In recent years, important advances have been made in technology for both ground-based and in-flight simulators. There has equally been a broadening of the use of flight simulators for research, development and training purposes.</p> <p>The objectives of this AGARD Flight Mechanics Panel Symposium were to provide an up-to-date description of the state-of-the-art of technology and engineering for both</p> <p>P.T.O</p>	<p>AGARD-CP-408</p> <p>Flight simulators Flight simulation Control simulation Pilot training Training simulators</p>	<p>AGARD Conference Proceedings No.408 Advisory Group for Aerospace Research and Development, NATO FLIGHT SIMULATION Published September 1986 372 pages</p> <p>In recent years, important advances have been made in technology for both ground-based and in-flight simulators. There has equally been a broadening of the use of flight simulators for research, development and training purposes.</p> <p>The objectives of this AGARD Flight Mechanics Panel Symposium were to provide an up-to-date description of the state-of-the-art of technology and engineering for both</p> <p>P.T.O</p>	<p>AGARD-CP-408</p> <p>Flight simulators Flight simulation Control simulation Pilot training Training simulators</p>

<p>ground-based and in-flight simulators and to place into context their respective roles within the aerospace scene. All papers were obtained by invitation.</p> <p>These Conference Proceedings, commissioned by the AGARD Flight Mechanics Panel contain a Technical Evaluation Report which is also available separately as an Executive Summary as AGARD AR 234.</p> <p>Papers presented at the Flight Mechanics Panel symposium held in Cambridge, United Kingdom, 30 September to 3 October 1985.</p> <p>ISBN 92-835-0394-5</p>	<p>ground-based and in-flight simulators and to place into context their respective roles within the aerospace scene. All papers were obtained by invitation.</p> <p>These Conference Proceedings, commissioned by the AGARD Flight Mechanics Panel contain a Technical Evaluation Report which is also available separately as an Executive Summary as AGARD AR 234.</p> <p>Papers presented at the Flight Mechanics Panel symposium held in Cambridge, United Kingdom, 30 September to 3 October 1985.</p> <p>ISBN 92-835-0394-5</p>
<p>ground-based and in-flight simulators and to place into context their respective roles within the aerospace scene. All papers were obtained by invitation.</p> <p>These Conference Proceedings, commissioned by the AGARD Flight Mechanics Panel contain a Technical Evaluation Report which is also available separately as an Executive Summary as AGARD AR 234.</p> <p>Papers presented at the Flight Mechanics Panel symposium held in Cambridge, United Kingdom, 30 September to 3 October 1985.</p> <p>ISBN 92-835-0394-5</p>	<p>ground-based and in-flight simulators and to place into context their respective roles within the aerospace scene. All papers were obtained by invitation.</p> <p>These Conference Proceedings, commissioned by the AGARD Flight Mechanics Panel contain a Technical Evaluation Report which is also available separately as an Executive Summary as AGARD AR 234.</p> <p>Papers presented at the Flight Mechanics Panel symposium held in Cambridge, United Kingdom, 30 September to 3 October 1985.</p> <p>ISBN 92-835-0394-5</p>

END

DATE
FILMED

12-86

DT