

XEROCOPY RESOLUTION TEST CHART  
NATIONAL BUREAU OF STANDARDS 1963-A

AD-A173 898

11

DAAK70-85-C-0083

PURIFICATION OF HYDROGEN GAS STREAMS

J.G. Wijmans, R.W. Baker, J. Louie and P.H. Pfromm  
Membrane Technology and Research, Inc.  
1030 Hamilton Court  
Menlo Park, CA 94025

July 1986

FINAL TECHNICAL REPORT  
For Period 19 August 1985 - 18 May 1986

Approved for public release; distribution is unlimited.

Prepared for:  
Department of the Army  
Belvoir RD&E Center  
Logistics Support Directorate  
STRBE-FGC  
Ft. Belvoir, VA 22060-5606

DCASMA-San Francisco  
1250 Bayhill Drive  
San Bruno, CA 94066

Contract DAAK70-85-C-0083

*Handwritten initials*

2 1986  
A  
2

DTIC FILE COPY

96 10 29 015

### NOTICE

This report was prepared as an account of work sponsored by an agency of the United States Government. Neither the United States nor any agency thereof, nor any of its employees, nor any of its contractors, subcontractors, or their employees, make any warranty, expressed or implied, or assumes any legal liability or responsibility for any third party's use or the results of such use of any information, apparatus, product or process disclosed in this report or represents that its use by such third party would not infringe privately owned rights.

### DISCLAIMERS

The citation of tradenames and names of manufacturers in this report is not to be construed as official Government endorsement or approval of commercial products or services referenced herein.

### DISPOSITION

Destroy this report when it is no longer needed. Do not return it to originator.

SECURITY CLASSIFICATION OF THIS PAGE

REPORT DOCUMENTATION PAGE				
1a. REPORT SECURITY CLASSIFICATION <b>UNCLASSIFIED</b>		1b. RESTRICTIVE MARKINGS		
7a. SECURITY CLASSIFICATION AUTHORITY		3. DISTRIBUTION/AVAILABILITY OF REPORT Approved for Public Release - Distribution is Unlimited		
2b. DECLASSIFICATION/DOWNGRADING SCHEDULE				
4. PERFORMING ORGANIZATION REPORT NUMBER(S) DAAK70-85-C-0083		5. MONITORING ORGANIZATION REPORT NUMBER(S) DAAK70-85-C-0083		
6a. NAME OF PERFORMING ORGANIZATION Membrane Technology and Research, Inc.	6b. OFFICE SYMBOL (If applicable)	7b. NAME OF MONITORING ORGANIZATION DCASMA - San Francisco		
6c. ADDRESS (City, State and ZIP Code) 1030 Hamilton Court Menlo Park, CA 94025		7c. ADDRESS (City, State and ZIP Code) 1250 Bayhill Drive San Bruno, CA 94066		
8a. NAME OF FUNDING/SPONSORING ORGANIZATION Belvoir RD&E Center	8b. OFFICE SYMBOL (If applicable) STRBE-FGC	9. PROCUREMENT INSTRUMENT IDENTIFICATION NUMBER DAAK70-85-C-0083		
8c. ADDRESS (City, State and ZIP Code) Logistics Support Directorate Ft. Belvoir, VA 22060-5606		10. SOURCE OF FUNDING NOS		
11. TITLE (Include Security Classification) (unclassified) Purification of Hydrogen Gas Streams		PROGRAM ELEMENT NO. 62733A	PROJECT NO. 1L665502 MM40	TASK NO. EE
				WORK UNIT NO. 038
12. PERSONAL AUTHOR(S) J.G. Wijmans, R.W. Baker, J. Louie, P. Pfromm				
13a. TYPE OF REPORT FINAL	13b. TIME COVERED FROM 8/19/85 TO 5/18/86	14. DATE OF REPORT (Yr., Mo., Day) July 1986	15. PAGE COUNT 47 total	
16. SUPPLEMENTARY NOTES				
17. COSATI CODES		18. SUBJECT TERMS (Continue on reverse if necessary; and identify by block number)		
FIELD	GROUP	SUB. GR.		
10	02			
11	04	39. CM		
19. ABSTRACT (Continue on reverse if necessary and identify by block number) 00005 0001 CO				
This report contains the results of a six month feasibility study aimed at the development of high flux palladium-silver membranes for purification of hydrogen gas streams. Membranes were prepared by coating palladium-silver layers onto a variety of support materials using a vacuum sputtering technique. The palladium-silver layers formed were generally less than 0.1 micron thick. Very finely porous or nonporous support materials were required to obtain high quality membranes. The best membranes are extremely selective, with a hydrogen/nitrogen selectivity in the range 150 to 600. These selectivities, combined with hydrogen fluxes ranging from $5 \times 10^{-5}$ to $10^{-4}$ cm <sup>3</sup> (STP)/cm <sup>2</sup> sec/cmHg make the performance of these membranes far superior to any existing membranes.				
20. DISTRIBUTION/AVAILABILITY OF ABSTRACT UNCLASSIFIED/UNLIMITED <input type="checkbox"/> SAME AS RPT <input type="checkbox"/> DTIC USERS <input checked="" type="checkbox"/>		21. ABSTRACT SECURITY CLASSIFICATION Unclassified		
22a. NAME OF RESPONSIBLE INDIVIDUAL Edward G. Starkovich		22b. TELEPHONE NUMBER (Include Area Code) (703) 664-5870	22c. OFFICE SYMBOL STRBE-FGC	



List of Figures	Page
Fig. 1. The electrolyte held between the porous conductive electrodes transports the ions which carry the current from one electrode to the other.....	2
Fig. 2. Scanning electron micrograph of an asymmetric gas separation membrane.....	4
Fig. 3. Palladium-silver membrane structure.....	6
Fig. 4. Bell jar of sputtering unit.....	9
Fig. 5. Schematic diagram of a support film casting machine....	12
Fig. 6. Thin film coating apparatus.....	12
Fig. 7. Thickness of palladium-silver layer vs. sputter time. Valid for standard sputter conditions.....	14
Fig. 8. Permeation apparatus.....	15
Fig. 9. Permeation rate of gases through sputter coated (Pd) membranes as a function of sputter time. Support: Microporous polysulfone (PSf).....	20
Fig. 10. Pd/Ag coating (a) bridging and (b) not bridging the pore in the PSf support.....	21
Fig. 11. PSf/SR-Pd: 6 minute sputter time; 5,000x magnification	28
Fig. 12. PEI-2-Pd: 2 minute sputter time; 1,000x magnification	28
Fig. 13. PSf/SR-Pd: 10 minute sputter time; 200x magnification	30
Fig. 14. PEI-1/SR-Pd/Ag: 30 minute sputter time; 5,000x magnification.....	30
Fig. 15. PEI-1/SR-Pd/Ag: 30 minute sputter time; 1,000x magnification.....	31
Fig. 16. Normalized H <sub>2</sub> flux vs. H <sub>2</sub> /N <sub>2</sub> selectivity for polymeric membranes, Monsanto's commercially available Prism <sup>®</sup> membrane, and the best Pd/Ag membranes produced in this program.....	32
Fig. A-1. PSf/SR coated with Pd.....	37
Fig. A-2. PSf/SR coated with Pd.....	37
Fig. B-1. PEI-1 coated with Pd.....	39

List of Tables	Page
Table 1. Permeation Rates for PTFE-Pd/Ag and PEI-2-Pd.....	18
Table 2. Selectivity of PSf-Pd Membranes.....	18
Table 3. Permeation Rates and Selectivities for PSf/SR-Pd/Ag-SR Membranes.....	22
Table 4. Permeation Rates and Selectivities for PSf/SR/TPX-Pd/ Ag-SR Membranes.....	23
Table 5. Permeation Rates and Selectivities for PSf/SR/EC-Pd/Ag- SR Membranes.....	24
Table 6. Permeation Rates and Selectivities for PEI-1-Pd/Ag-SR Membranes.....	25
Table 7. PEI-1/SR-Pd/Ag and PEI-1/SR-Pd/Ag-SR Multicomposite Membranes.....	26
Table 8. Permeation Rates and Selectivities for PEI-1/TPX-Pd/Ag- SR Membranes.....	27
Table A-1. Selectivities of PSf/SR Support Membranes.....	35
Table A-2. Permeation Rates and Selectivities for PSf/SR-Pd/Ag-SR- Pd/Ag Membranes.....	36
Table B-1. PEI-1-Pd/Ag-SR-Pd/Ag Multilayer Composite Membranes....	40

## TABLE OF CONTENTS

	Page
SIGNIFICANCE OF THE PROBLEM.....	1
BACKGROUND.....	1
Fuel Cells.....	1
Hydrogen Purification with Synthetic Membranes...	3
PHASE I APPROACH.....	5
METHODS OF METAL DEPOSITION.....	7
Vacuum Evaporation.....	7
Vacuum Sputtering.....	7
MATERIAL SELECTION.....	8
METHODS OF MEMBRANE PREPARATION AND EVALUATION.....	11
Support Membrane Preparation.....	11
Deposition of the Palladium/Silver Layer.....	11
Membrane Evaluation.....	13
RESULTS AND ANALYSIS OF MEMBRANE PERFORMANCE.....	17
PTFE and PEI-2 Supports.....	17
PSf Support.....	18
PSf/SR Support.....	19
PSf/SR/TPX Support.....	23
PSf/SR/EC Support.....	24
PEI-1 Support.....	24
PEI-1/SR Support.....	25
PEI-1/TPX Support.....	27
Scanning Electron Microscopy.....	27
COMPARISON OF THE BEST PALLADIUM/SILVER MEMBRANES WITH POLYMERIC MEMBRANES.....	29
CONCLUSIONS.....	33
REFERENCES.....	34
APPENDIX A.....	35
APPENDIX B.....	38

## SIGNIFICANCE OF THE PROBLEM

The Army is interested in developing hydrogen-powered phosphoric acid fuel cells as mobile power sources. These cells require hydrogen gas of relatively high purity as a fuel.<sup>(1,2)</sup> Hydrogen streams obtained from fuel processors such as methane steam reformers, oil and coal gasifiers, or catalytic crackers of hydrocarbon fuels, usually contain less than 80% hydrogen.<sup>(3)</sup> The other gases in these streams, H<sub>2</sub>S, SO<sub>2</sub>, NO<sub>x</sub>, CO, CO<sub>2</sub>, CH<sub>4</sub>, etc., must be removed since they can reduce the efficiency of the fuel cell. The goal of this program is to develop a continuous process able to produce hydrogen containing less than 1% impurities from this type of feed stream.

## BACKGROUND

### FUEL CELLS

A fuel cell is a device that continuously converts chemical energy into electrical energy. The simplest fuel cells run on hydrogen and oxygen, and their operation is the converse of the electrolysis of water. A simple hydrogen/oxygen cell is shown in Figure 1. The anode is supplied with hydrogen and the cathode with oxygen. Both electrodes are electrically conductive and porous, so that gases can diffuse through them. An electrolyte, usually a strong acid or alkali, is held between the two electrodes, and prevents mixing of the anode and cathode feed, while permitting ions to pass from one electrode to the other carrying an electrical current. An external resistance is connected across the electrodes and the work done by the cell is measured by the current through the resistance. The highest exchange current densities are obtained with platinum electrodes.

The overall chemical reaction in the cell can be written:

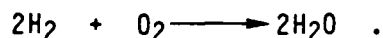

In an acid electrolyte cell, the hydrogen and oxygen reactions are:

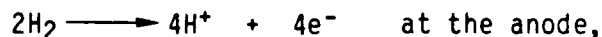

A mobile fuel cell can operate with hydrogen produced from hydrocarbon fuels and air. Operation with air requires the use of an acid electrolyte to avoid carbonation problems from atmospheric carbon dioxide. Hydrogen obtained from hydrocarbon fuels contains other gases which reduce the efficiency of the fuel cell. In particular, carbon monoxide can poison the platinum electrodes. The impurities in the hydrogen feed stream must therefore be reduced to a small percentage. Thus, a prerequisite

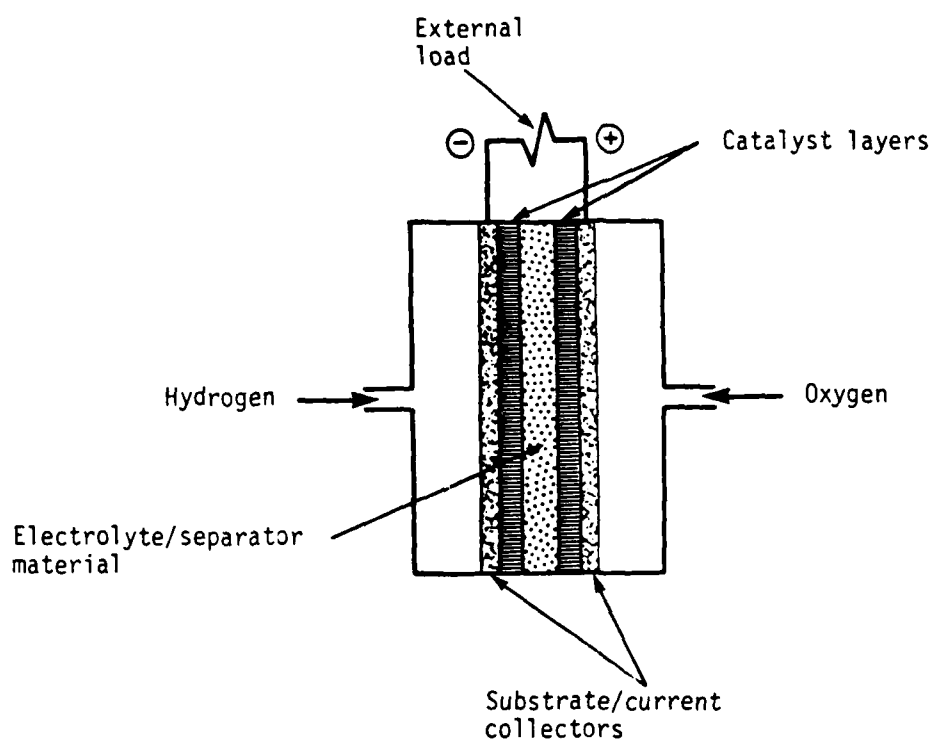

Figure 1. The electrolyte held between the porous conductive electrodes transports the ions which carry the current from one electrode to the other.

of an efficient mobile fuel cell system is a method of purifying the hydrogen feed stream. It should also be taken into consideration that these fuel cells operate much more efficiently at temperatures around 200°C.

#### HYDROGEN PURIFICATION WITH SYNTHETIC MEMBRANES

Conventional techniques used to purify hydrogen streams include adsorption or absorption processes and cryogenic techniques. However, these techniques are not suitable for a mobile fuel cell application. For this application, the process must be able to recover most of the hydrogen contained in the feed stream and lose only a small fraction with the impurity gases; i.e., the system should operate at high hydrogen recovery rates. The process must also be able to operate at fuel cell temperatures of 200°C. In addition, the process should be adaptable to a small, compact, rugged unit capable of operating under field conditions with minimal maintenance and supervision.

In recent years, synthetic semipermeable membrane processes have been developed which could be used for this separation. More than 60 membrane hydrogen separation plants are now in operation worldwide.<sup>(4,5)</sup> The polymer membranes used in these plants are asymmetric structures consisting of an extremely thin permselective layer (0.2 to 1 micron thick) supported on a microporous, non-selective support layer. A scanning electron micrograph of this type of membrane is shown in Figure 2. Because the permselective layer is very thin, the membrane fluxes are high and the plants are quite compact. Apart from a gas compressor, these membrane processes have no moving parts and can be adapted to either very small or large scale operation. A membrane process could thus be made sufficiently rugged and compact for the fuel cell application. Membrane processes are also relatively energy efficient. However, the polymer membranes currently available are insufficiently selective or thermally stable to produce hydrogen of the required purity for fuel cell operation. These polymer membranes typically have a selectivity to hydrogen over the other gases contained in fuel cell hydrogen feed streams of between 10 and 20.<sup>(6)</sup> This selectivity is insufficient to produce hydrogen in a single step with less than 1% of impurities from a stream containing less than 80% hydrogen. A more hydrogen selective membrane is therefore required.

Palladium and palladium alloy metal membranes have the required selectivity and thermal stability. These membranes were extensively studied during the 1950's and 60's, and this work led to the installation by Union Carbide of a plant to separate hydrogen from a refining off-gas stream containing CH<sub>4</sub>, C<sub>2</sub>H<sub>4</sub>, CO, and H<sub>2</sub>S.<sup>(7-11)</sup> The plant was able to produce >99.9% pure hydrogen in a single pass through the membrane. Twenty-five micron thick palladium-silver membranes were used at 370°C and at a feed pressure of 450 psi. However, because the fluxes through the 25 micron thick membranes were low, the process was not sufficiently economically attractive to encourage wide use.

Dense skin layer

Microporous support

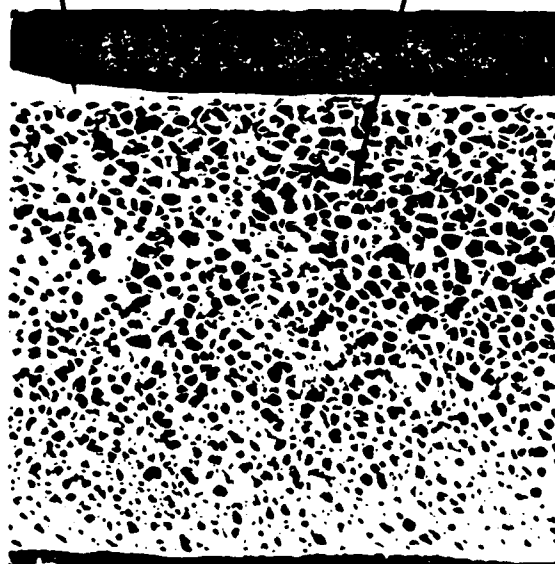

10  $\mu$ m

Figure 2. Scanning electron micrograph of an asymmetric gas separation membrane.

This problem could be overcome by making thinner membranes. If the membrane thickness could be reduced to 0.5 to 2.5 microns, the membrane flux would increase ten to fifty-fold, making the flux comparable to that of current composite polymer membranes.

#### PHASE I APPROACH

The objective of this program was to develop ultrathin and ultrasensitive palladium metal membranes for the purification of hydrogen gas streams. However, pure palladium membranes have been found to undergo severe deformations after thermal and hydrogen pressure cycling. Palladium-silver alloys have a much better mechanical stability and an alloy containing 76% by weight palladium and 24% silver was used in this program. Thin metal films were deposited on a suitable support material. The support material was chosen both for its high gas permeability and the ability to provide a surface suited for the deposition of a very thin metal layer. The metal film used consists of 76% by weight palladium and 24% silver. This palladium-silver alloy combines an optimum hydrogen permeability with a high mechanical stability.

The methods used for the metal deposition are discussed under the heading "METHODS OF METAL DEPOSITION".

Different structures were envisioned for the composite palladium-silver membranes. Figure 3 shows two structures, both of which were made during this program. In Figure 3(a), the palladium-silver (Pd/Ag) permselective layer is deposited directly onto the microporous support. A problem with this structure is that the layer is too thin to bridge the pores of the microporous support. In this case the Pd/Ag layer will not affect the selectivity of the membrane. Even if the Pd/Ag layer bridges the pores, it probably will contain pinholes and defects. A silicone rubber sealing layer is therefore applied on top of the Pd/Ag layer to prevent convective bulk flow of gases through the defects.

Figure 3(b) shows an alternative approach; a silicone rubber sealing layer is used to coat the pores in the microporous support, with the Pd/Ag layer deposited on top. Again, due to its thinness, the Pd/Ag layer may contain pinholes and defects. However, bulk flow of gases through the defects is prevented by the silicone rubber layer.

If required, the membrane structure of Figure 3(b) can be recoated with silicone rubber to protect the Pd/Ag layer and thus enhance the mechanical stability of the composite. Furthermore, the sealing layer may be made from materials other than silicone rubber. In this Phase I feasibility program, only small membrane samples 2-3 inches in diameter were produced.

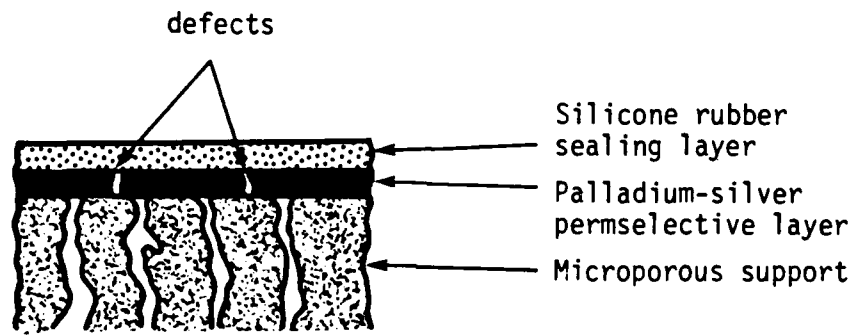

(a) Silicone coated composite membrane

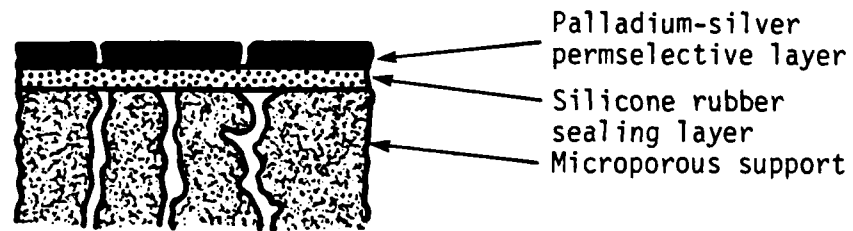

(b) Palladium-silver composite membrane

Figure 3. Palladium-silver membrane structures.

The membranes are characterized by measuring their permeabilities to H<sub>2</sub>, N<sub>2</sub> and CO<sub>2</sub>. Using these data one can predict by interpolation the permeability of other gases. The permeability of dense membranes to gases invariably adheres to the following rank order: permeability H<sub>2</sub>>CO<sub>2</sub>>O<sub>2</sub>>CO>>CH<sub>4</sub>>>N<sub>2</sub>.

#### METHODS OF METAL DEPOSITION

There are two methods of depositing thin Pd/Ag alloys: vacuum evaporation and vacuum sputtering. Descriptions of these follow.

##### VACUUM EVAPORATION

Vacuum evaporation is performed in a chamber which is evacuated to a high vacuum. The chamber contains the substrate to be coated, and, in the present case, the palladium/silver source. The partial pressure of the metal in the chamber is set by heating the metal sample. The metal atoms leave the source and are deposited on the substrate. The palladium to silver deposition ratio is determined mainly by the surface of each metal source that is available for the evaporation step.

Vacuum evaporation equipment is available both in laboratory size and in large-scale production units capable of continuously coating films several feet wide. One objective of the Phase I program was to have a limited number of vacuum evaporation membranes prepared by Dr. H. Strathmann at the Fraunhofer Gesellschaft in West Germany. Dr. Strathmann's laboratory is equipped with vacuum deposition equipment. However, due to problems with the equipment, no significant results were obtained.

##### VACUUM SPUTTERING

In general, the quality and reproducibility of metal layers obtained by vacuum sputter coating are superior to those obtained through evaporative means. Vacuum sputtering is a microscopic process involving clouds of metal atoms as opposed to the "spray" of relatively large macroscopic clumps of evaporated metal used in vacuum evaporation. In sputtering, there are no restrictions with respect to gravitational forces in electrode or specimen arrangement.

Sputtering is an atom-by-atom process by which one can obtain nonporous films with surfaces which reproduce the surface finish of the specimen. The atoms disperse throughout the process chamber in such a way as to provide adequate coating of irregularly shaped specimens without having to tilt or rotate them. The metal atoms are cool, therefore no thermally induced damage results. Finally, sputtering usually leads to fewer pinhole defects, since shadowing effects from dust particles become less pronounced.

Vacuum sputtering is the technique used in this program and is discussed in detail below. A Hummer VI Sputtering System (Anatech, Ltd.) was used. Figure 4 shows a schematic of this system. In a low pressure (20 - 60 millitorr) argon atmosphere, a cold plasma is formed by applying a negative potential of 3,000 volts to the top plate. This voltage ionizes the argon gas and produces a plasma consisting of argon ions and the liberated electrons.

The ionized gas atoms are heavy but have relatively little kinetic energy unless accelerated through an electric field. When this is done, they bombard the negatively charged target and dislodge metal atoms which randomly diffuse and eventually adhere to the substrate.

A problem associated with the ion movement toward the target is the movement of energetic electrons in the opposite direction, i.e., towards the substrate. These electrons transfer their energy to the substrate and the substrate's temperature increases substantially. To avoid the damaging effects of electron bombardment, a planar magnet is used to deflect the electrons present in the plasma into a spiral path away from the substrate. In addition to the magnet, an electrically charged dark space shield surrounds the pedestal. This biased ring attracts electrons which may have escaped through the magnetic field. The result is a cool pedestal and substrate.

#### MATERIAL SELECTION

The membranes developed consist of a selective palladium/silver alloy layer deposited on a polymer support. Ideally, the support membrane does not influence the composite membrane's selectivity. This will only be achieved if the resistance of the support membrane to gas flow is much lower than the resistance of the metal layer. Furthermore, the structure of the sputtered metal layer is very dependent on the surface structure of the support membrane. The ideal support, therefore, would combine a high gas flux with an essentially nonporous (or pinhole and defect free) surface on which the palladium/silver layer can be deposited. The support must also be strong enough to withstand the operating conditions of the system. Unfortunately, high permeability is usually associated with high porosity, and low permeability with low porosity.

Several supports were considered, ranging from very permeable microporous films (PTFE and PEI-2), to moderately permeable (PSf/SR), to relatively impermeable dense films (PEI-1).

The following were evaluated:

1. PSf: A microporous membrane made from polysulfone (PSf) cast on a polyester fabric. Polysulfone is a high flux membrane that is selective for H<sub>2</sub>. Source: MTR.

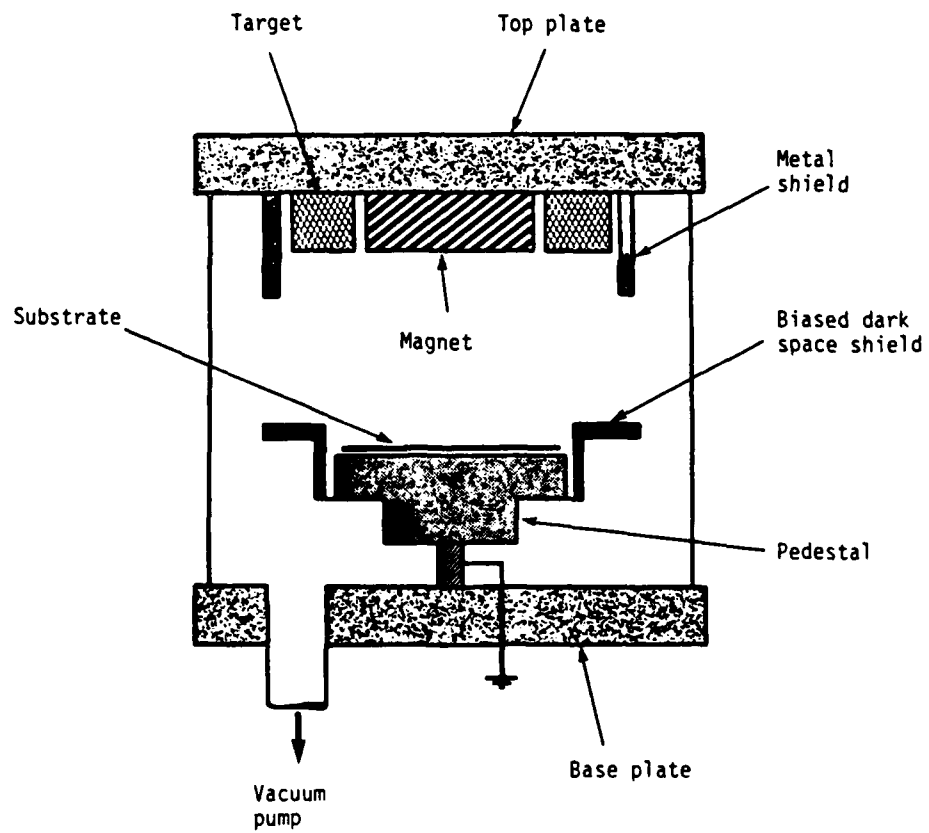

Figure 4. Bell jar of sputtering unit.

2. PSf/SR: A microporous polysulfone membrane coated with a thin layer of silicone rubber (SR). Coating thickness varies from 0.1 to 5.0 microns. The silicone rubber coats the pores in the polysulfone and leaves a smooth surface for deposition. The silicone rubber layer determines the gas permeability properties and this support is selective for CO<sub>2</sub>. Source: MTR.
3. PSf/SR/TPX: A silicone-rubber-coated polysulfone membrane (PSf/SR), coated with polymethylpentene (TPX) layers varying from 0.3 to 20.6 microns in thickness. TPX is the least permeable layer and is H<sub>2</sub> selective. Source: MTR.
4. PSf/SR/EC: A silicone-rubber-coated polysulfone membrane (PSf/SR) coated with ethylcellulose (EC). The 0.9 micron thick ethylcellulose layer is the selective layer and is selective for CO<sub>2</sub>. Source: MTR.
5. PEI-1: An asymmetric, dense membrane made from a polyetherimide (PEI). PEI-1 is a low flux membrane and is selective for H<sub>2</sub>. The surface of the PEI-1 support is very finely porous. Source: GKSS, Germany.
6. PEI-1/SR: PEI-1 coated with silicone rubber. The selectivity of this support is determined by the PEI-1. The silicone rubber layer coats the pores on the surface of the PEI-1. Source: MTR.
7. PEI-1/TPX: PEI-1 coated with TPX. The TPX, like silicone rubber, coats the pores of the PEI-1. Source: MTR.
8. PEI-2: A microporous membrane made from a polyetherimide. PEI-2 is a high flux membrane with a porous surface and is selective for H<sub>2</sub>. Source: MTR.
9. PTFE: A microporous membrane made from pure polytetrafluoroethylene (PTFE). It is H<sub>2</sub> selective and the pore diameters are 0.02 and 0.2 micron, which result in high fluxes. Source: Gore & Associates.

The surfaces of the nine support materials listed above differ in porosity and in chemical nature. The latter may determine the degree of adherence of the palladium/silver layer to the support. The materials are capable of withstanding temperatures up to 150°C with the exception of PTFE which is stable up to 250°C.

## METHODS OF MEMBRANE PREPARATION AND EVALUATION

### SUPPORT MEMBRANE PREPARATION

All support materials, except the polytetrafluoroethylene (PTFE) membranes and the finely porous polyetherimide membrane (PEI-1), were made by MTR. A description of the preparation methods follows.

#### Preparation of the Microporous Polysulfone (PSf) and Polyetherimide (PEI-2) Membranes

These membranes are prepared using the casting machine shown in Figure 5. The casting solution, consisting of polysulfone or polyetherimide dissolved in a water miscible solvent, is doctored onto a moving belt of polyester fabric. The belt then passes into a water bath which precipitates the polymer to form the microporous membrane. The belt is then collected on a take-up roll, after which the membrane is washed overnight to remove any remaining solvent and dried to form the support membrane. The resulting support is 50 to 60 microns thick.

#### Application of the Coating and Sealing Layers

The apparatus used to make the coating and sealing layers is shown in Figure 6. The support membrane from a feed roll passes through the dip coating tank and a drying oven, and is then wound up on a product roll. The dip coating tank contains a dilute solution of the coating polymer and coats the moving membrane support with a liquid layer 50 to 100 microns thick. After evaporation of the solvent, a polymer film 0.5 to 10 microns thick is left on the membrane. In an alternative method, a wick box is used instead of the dip coating tank. The wick box contains the polymer solution that is drawn up by sponge wick extruding from the box. This sponge wick is in contact with the support membrane and a thin liquid layer is coated on the support.

Multilayer coatings are achieved by running the support membrane more than once through the coating apparatus. Different coating solutions may be used for each run.

### DEPOSITION OF THE PALLADIUM/SILVER LAYER

The mechanism of vacuum sputtering is described under the heading "METHODS OF METAL DEPOSITION". The sputtering procedure is as follows:

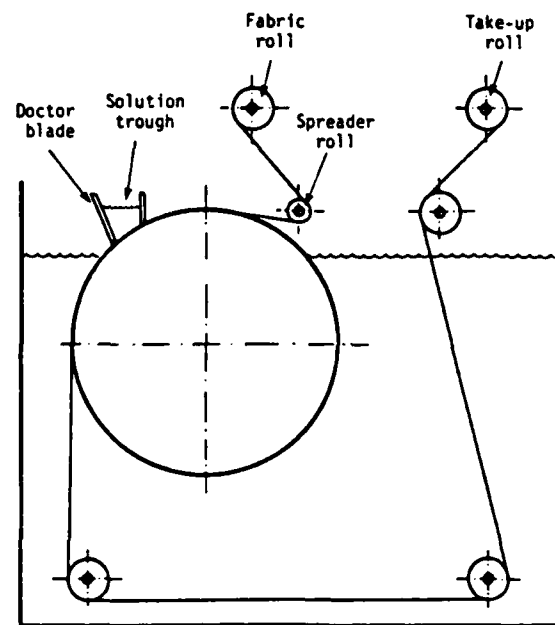

Figure 5. Schematic diagram of a support film casting machine.

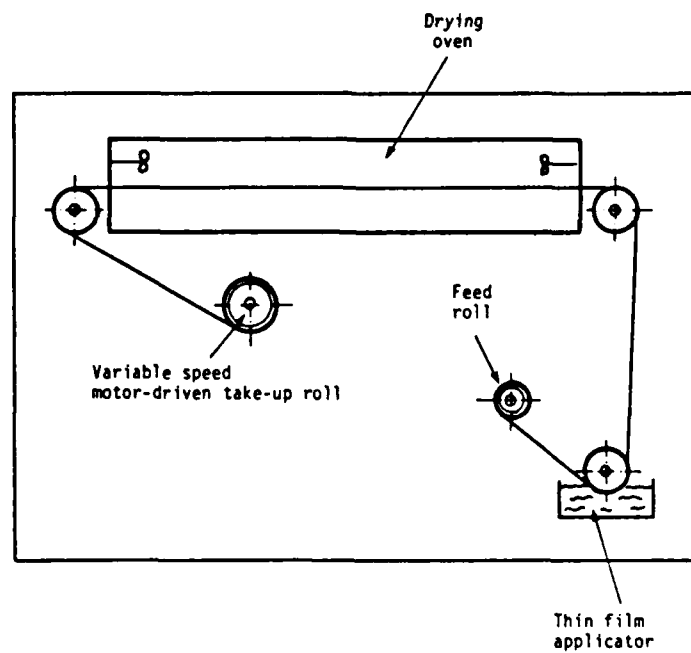

Figure 6. Thin film coating apparatus.

A membrane stamp with a diameter of 4.75 cm is cut from the support membrane material. To remove as much of the dust as possible from the surface, a chlorofluorocarbon under pressure is used to blow off the dust. This substance leaves no residue, nor does it contain water vapor, which could condense on the support surface. This method does not scratch, damage or contaminate the surface as some mechanical cleaning methods might, e.g., a soft brush or a finger tip.

After removing all the dust possible, the membrane stamp is placed in the sputter chamber. The system is pumped down to 50 millitorr before the chamber is flushed three times with argon gas. After the flushing, the system is pumped down to at least 30 millitorr. Subsequently, an argon inlet flow rate is maintained such that the pressure stays at 55 to 60 millitorr.

A high voltage is then applied to the top plate to produce the plasma. The high voltage control and the plasma discharge current (10 milliamps) are held constant during the sputter runs. These parameters control the Pd/Ag sputter rate. The sputter time ranges from 16 seconds to 1 hour; with 2, 5 and 10 minutes as the standard times. The thickness of the sputtered layer increases linearly with sputter time. A graph correlating the thickness of the palladium-silver layer vs. the sputter time is provided by the manufacturer of the sputter unit, see Figure 7. Weighing a number of samples before and after the sputter run proved this graph is fairly dependable.

After sputtering, the membranes are dip coated in silicone rubber which acts as a defect sealing layer. Silicone rubber is extremely permeable to hydrogen and will prevent the bulk flow of gases through any membrane defects, thereby effectively reducing the flow of gas through these defects by 100 to 1000 times. The silicone rubber layer also protects the fragile Pd/Ag layer from being scratched or rubbed off during handling or testing. The silicone rubber layer is allowed to dry overnight before the multilayer composite Pd/Ag membrane is ready for testing.

## MEMBRANE EVALUATION

### Permeability Measurements

The composite membranes were tested in the gas permeation apparatus shown in Figure 8. The membranes have an effective area of 12.5 cm<sup>2</sup> through which gases may permeate. Up to three membranes can be tested at one time. The membranes were tested initially at both 10 and 50 psig feed pressure, but, because the membranes' permeability was constant in this range all subsequent tests were made at 50 psig. Each membrane was tested with CO<sub>2</sub>, N<sub>2</sub> and H<sub>2</sub>, at room temperature and at 80°C.

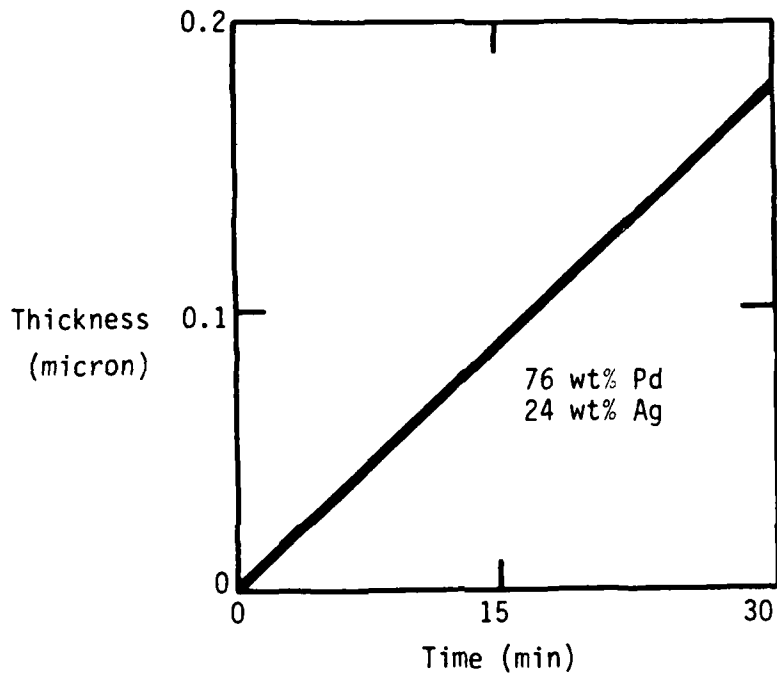

Figure 7. Thickness of palladium-silver layer vs. sputter time. Valid for standard sputter conditions.

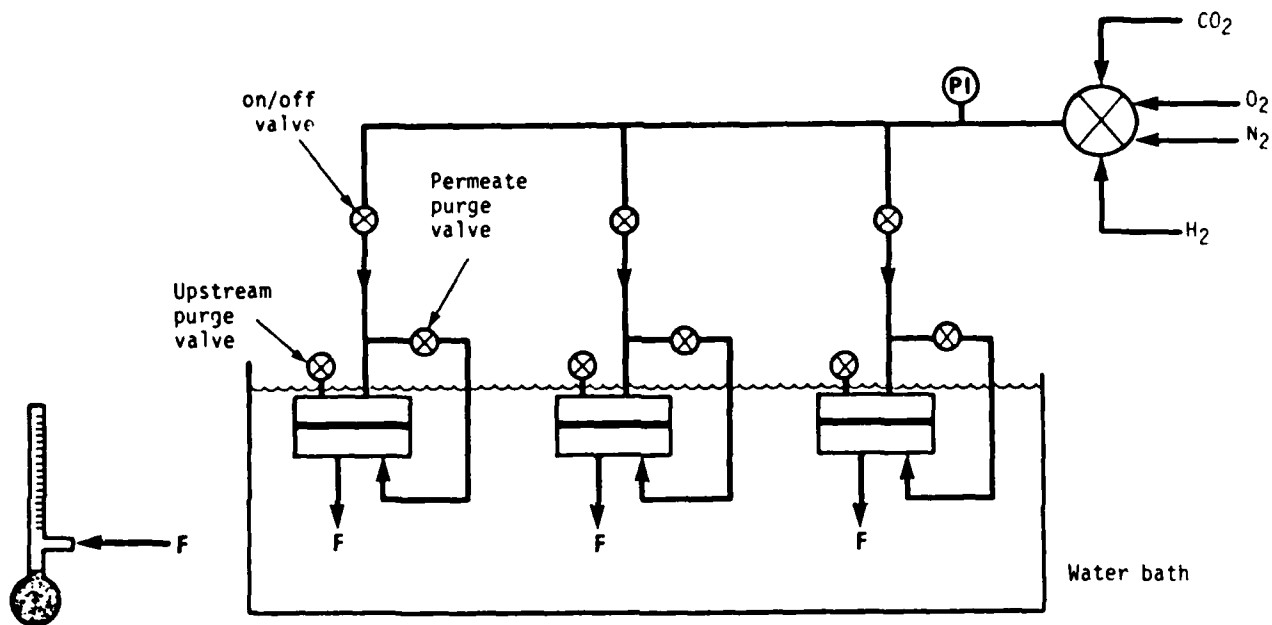

Figure 8. Permeation apparatus.

Both the high pressure line and the permeate lines were purged with the succeeding gas in order to remove all traces of the prior gas. This reduced the time required for the gas to come to equilibrium with the membrane and yield consistent readings. Gas flow measurements were made with bubble meters.

The normalized permeation rate of the membrane to various gases is determined by the equation:

$$P = \frac{V}{Ap} \quad (1)$$

where  $P$  = permeation rate,  $\text{cm}^3(\text{STP})/(\text{cm}^2 \text{ sec cmHg})$   
 $V$  = volume flow,  $\text{cm}^3(\text{STP})/\text{sec}$   
 $A$  = area,  $\text{cm}^2$   
 $p$  = pressure difference over membrane,  $\text{cmHg}$

The selectivity,  $\alpha$ , which is used to evaluate the effective separation of a membrane for gas 1 over gas 2, is described by

$$\alpha_{1,2} = P_1/P_2. \quad (2)$$

Equation (1) assumes that the permeation rate is proportional to the difference in pressure across the membrane. This is true for the permeation of gases through polymeric membranes, but not for the permeation of hydrogen through palladium/silver films. In the latter case, the permeation rate is proportional to the difference in the square roots of the upstream and downstream pressure. Therefore, equation (1) cannot be used to predict the hydrogen permeation rates for pressures that differ substantially from the pressure used in the experiments (10 and 50 psig).

#### Scanning Electron Microscopy

Membrane surfaces and membrane cross-sections were examined using a Cambridge 5600 Electron Microscope. Cross-sections were obtained by soaking the membrane in ethanol and subsequently breaking the membrane at liquid nitrogen temperature. A cross-section consists mainly of nonconducting polymeric material and has to be coated with a thin gold layer prior to the SEM examination. Palladium-silver surfaces can be examined without further treatment.

## RESULTS AND ANALYSIS OF MEMBRANE PERFORMANCE

The different support membranes can be classified in order of decreasing pore size and porosity of top layer as follows:

Polytetrafluoroethylene filter membranes -- PTFE

Microporous polyetherimide membranes -- PEI-2

Polysulfone support membranes -- PSf

Polyetherimide gas separation membranes -- PEI-1

Coated PSf and PEI-1 membranes:   PSf/SR  
  PSf/SR/TPX  
  PEI-1/SR  
  PEI-1/TPX  
  PSf/SR/EC

All these support materials were coated with palladium/silver for varying sputter times. Most Pd/Ag composites were subsequently hand-dipped in silicone rubber to protect the Pd/Ag layer. In the following sections, the most interesting results will be presented and discussed. Additional results, comprising the remainder of the membranes prepared and tested, can be found in Appendices A and B.

As shown in the detailed discussion that follows, some extremely good membranes were produced in this program. Our best membranes had high fluxes and much higher selectivities than any available polymer membranes. On the other hand, reproducibility was a continuing problem. As the program progressed and we became more experienced, the results became more consistent; but experimental scatter made the effect of changes in preparation parameters difficult to discern.

### PTFE AND PEI-2 SUPPORTS

Two teflon supports were used: one with a 0.02 micron pore diameter and one with a 0.2 micron pore diameter. Table 1 lists the permeation rates for these membranes and for the microporous PEI-2 support. These three supports have large pores that do not seem to have been bridged by the Pd or Pd/Ag layer. Since the Pd and Pd/Ag layers had little effect on the flux, we can conclude that these supports are too porous to serve as an effective support for Pd/Ag composite membranes.

Table 1. Permeation Rates for PTFE-Pd/Ag and PEI-2-Pd

Membrane	Sputter Time (min)	Permeation Rate [cm <sup>3</sup> (STP)/cm <sup>2</sup> sec·cmHg]		
		CO <sub>2</sub>	N <sub>2</sub>	H <sub>2</sub>
PEI-2-Pd	0	11x10 <sup>-2</sup>	8.1x10 <sup>-2</sup>	14x10 <sup>-2</sup>
PEI-2-Pd	4	6.9x10 <sup>-2</sup>	5.4x10 <sup>-2</sup>	9.3x10 <sup>-2</sup>
PEI-2-Pd	8	6.5x10 <sup>-2</sup>	5.1x10 <sup>-2</sup>	9.2x10 <sup>-2</sup>
PEI-2-Pd	14	4.0x10 <sup>-2</sup>	3.3x10 <sup>-2</sup>	6.4x10 <sup>-2</sup>
PTFE-Pd/Ag 0.02 μm	0	4.7x10 <sup>-2</sup>	4.6x10 <sup>-2</sup>	11x10 <sup>-2</sup>
PTFE-Pd/Ag 0.02 μm	10	4.7x10 <sup>-2</sup>	4.4x10 <sup>-2</sup>	11x10 <sup>-2</sup>
PTFE-Pd/Ag 0.02 μm	20	4.7x10 <sup>-2</sup>	4.4x10 <sup>-2</sup>	11x10 <sup>-2</sup>
PTFE-Pd/Ag 0.2 μm	0	75x10 <sup>-2</sup>	55x10 <sup>-2</sup>	81x10 <sup>-2</sup>
PTFE-Pd/Ag 0.2 μm	10	75x10 <sup>-2</sup>	55x10 <sup>-2</sup>	81x10 <sup>-2</sup>
PTFE-Pd/Ag 0.2 μm	20	89x10 <sup>-2</sup>	63x10 <sup>-2</sup>	100x10 <sup>-2</sup>

PSf SUPPORT

The microporous polysulfone (PSf) support was coated with pure palladium. Three different sputter times were used, with all other parameters held constant. The permeability of these palladium coated membranes and of the original uncoated support to five test gases (CH<sub>4</sub>, CO<sub>2</sub>, O<sub>2</sub>, N<sub>2</sub> and H<sub>2</sub>) was then measured. The results are presented in Figure 9 and Table 2.

Table 2. Selectivity of PSf-Pd Membranes

Membrane Selectivity α <sub>1,2</sub>	Sputter Time (min)				Theoretical Knudsen Selectivity
	0	1	5	10	
α <sub>H<sub>2</sub>/CH<sub>4</sub></sub>	1.9	2.2	2.8	2.7	2.8
α <sub>H<sub>2</sub>/CO<sub>2</sub></sub>	3.1	3.8	4.2	4.2	4.7
α <sub>H<sub>2</sub>/O<sub>2</sub></sub>	3.2	3.6	3.6	3.8	4.0
α <sub>H<sub>2</sub>/N<sub>2</sub></sub>	2.9	3.1	3.1	3.4	3.7

Figure 9 shows that the sputter coating drastically reduces the permeability of all gases through the membrane and that a longer sputter time produces a less permeable membrane. However, as shown in Table II, the membrane selectivity toward hydrogen was not markedly changed. The selectivity  $\alpha_{1,2}$  is defined as the ratio of the permeation rate of gas 1 to gas 2. A macroporous membrane will be nonselective, i.e., all  $\alpha$ 's are equal to 1. A finely porous membrane with pores smaller than the mean free path of the test gas will be partially selective, with a selectivity given by:

$$\alpha_{1,2} = (M_2/M_1)^{1/2} \quad (3)$$

where  $M_1$  and  $M_2$  are the molecular weights of gases 1 and 2, respectively. This is known as the Knudsen selectivity.

The untreated PSf support (sputter time = 0 in Table 2) has selectivities larger than one but smaller than the Knudsen selectivities. This indicates a wide distribution in pore diameters within the support. The Pd coating increases the selectivity of the membrane very slightly, but the selectivity still remains lower than the Knudsen selectivity and much lower than the selectivity expected for a nonporous Pd membrane. This indicates that the Pd layer does not bridge the pores, but merely coats the pore walls as is schematically shown in Figure 10. We conclude that the PSf support is too porous to serve as the backing for a highly selective Pd or Pd/Ag membrane, which requires an essentially nonporous Pd or Pd/Ag layer.

#### PSf/SR SUPPORT

PSf/SR was sputtered with Pd and Pd/Ag. These membranes were tested and found to have low permeation rates and low selectivities. More details of the results obtained with these membranes can be found in Appendix A. We believe the disappointing results are due to the brittleness of the Pd and Pd/Ag layers. Handling the composite membranes between preparation and evaluation damages the metal layer. To overcome this problem, membranes were dipped in a silicone rubber solution immediately after the vacuum sputtering run. The surface SR layer serves to protect the underlying Pd/Ag layer.

Two of the membranes were tested at 20°C and 80°C. The resulting permeation rates and selectivities are given in Table 3.

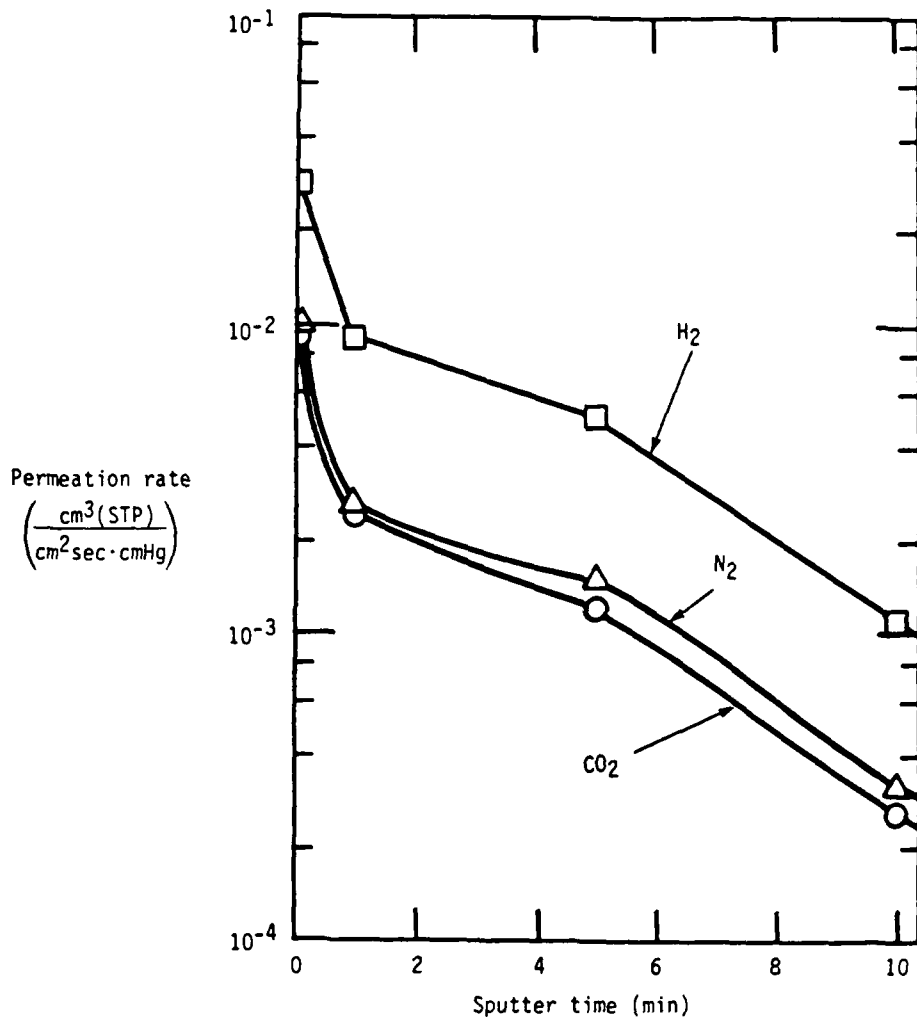

Figure 9. Permeation rate of gases through sputter coated (Pd) membranes as a function of sputter time. Support: Microporous polysulfone (PSf).

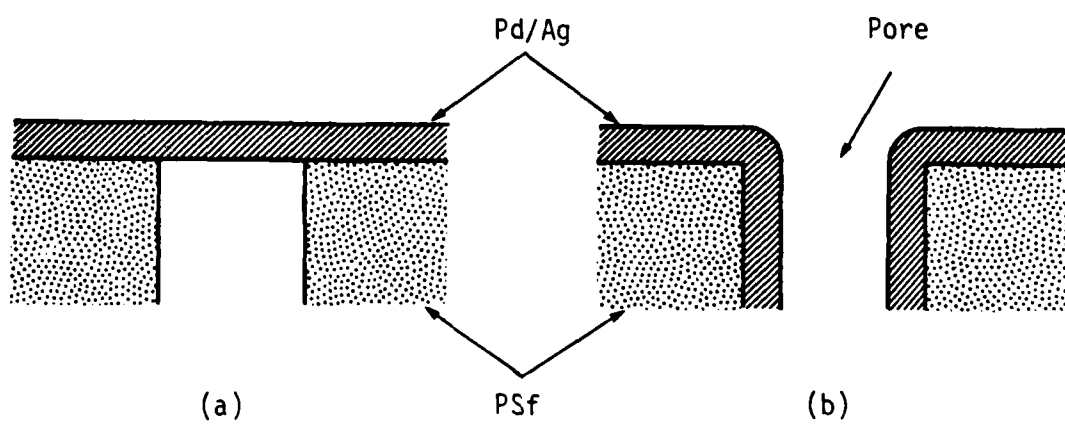

Figure 10. Pd/Ag coating (a) bridging and (b) not bridging the pore in the PSf support.

Table 3. Permeation Rates and Selectivities for  
PSf/SR-Pd/Ag-SR Membranes

Sputter Time (min)	Temp. (°C)	Permeation Rate [cm <sup>3</sup> (STP)/cm <sup>2</sup> sec·cmHg]			Selectivity	
		CO <sub>2</sub>	N <sub>2</sub>	H <sub>2</sub>	α <sub>H<sub>2</sub>/CO<sub>2</sub></sub>	α <sub>H<sub>2</sub>/N<sub>2</sub></sub>
0	20	2.5x10 <sup>-3</sup>	2.5x10 <sup>-4</sup>	8.0x10 <sup>-4</sup>	0.3	3.2
1	20	1.6x10 <sup>-6</sup>	1.0x10 <sup>-7</sup>	3.0x10 <sup>-5</sup>	19	300
	80	2.8x10 <sup>-6</sup>	5.8x10 <sup>-7</sup>	1.4x10 <sup>-4</sup>	50	241
2	20	1.7x10 <sup>-6</sup>	4.2x10 <sup>-7</sup>	1.3x10 <sup>-5</sup>	7.6	31
	80	9.3x10 <sup>-6</sup>	5.8x10 <sup>-7</sup>	9.3x10 <sup>-5</sup>	10	160
3	20	1.1x10 <sup>-6</sup>	4.5x10 <sup>-7</sup>	6.7x10 <sup>-6</sup>	6.1	15
5	20	1.3x10 <sup>-6</sup>	2.2x10 <sup>-7</sup>	4.1x10 <sup>-6</sup>	3.2	19

The membranes formed after sputtering with Pd/Ag for one and two minutes have relatively high H<sub>2</sub> permeation rates. The Pd/Ag layer reduced the permeation rate by at least 260 times for CO<sub>2</sub>, 400 times for N<sub>2</sub> and only 6 to 9 times for H<sub>2</sub>. The H<sub>2</sub> flux decreased less than the N<sub>2</sub> and CO<sub>2</sub> fluxes, thereby resulting in higher selectivities. The gas fluxes and selectivities can be seen to increase with increasing temperature. This was expected since Pd/Ag is more permeable to H<sub>2</sub> at higher temperatures. The selectivities also seem to be highest at the lower sputtering times, i.e., at one and two minutes.

The high H<sub>2</sub>/N<sub>2</sub> selectivity of these membranes suggests that the Pd/Ag layer contributes to the selectivity. Polysulfone and silicone rubber alone have H<sub>2</sub>/N<sub>2</sub> selectivities lower than 10. However, the higher permeation rate of CO<sub>2</sub> compared to N<sub>2</sub> is difficult to explain. In this context it is interesting that a recent paper by Mercea et al.<sup>(12)</sup> also shows surprisingly high CO<sub>2</sub> fluxes for Pd-polyethyleneterephthalate-Pd sandwich membranes.

Comparing the results in Table 3 with those for the membranes with unprotected Pd and Pd/Ag layers, it is apparent that protecting the Pd/Ag layer with a silicone rubber coating is beneficial, and this was done for all membranes prepared subsequently.

PSf/SR/TPX SUPPORT

A PSf/SR support was either wick or dip coated with TPX to give varying TPX thicknesses. TPX was used because it was expected that the Pd/Ag layer would adhere better to it than to silicone rubber. The results obtained are presented in Table 4. In general, the selectivity of H<sub>2</sub> to CO<sub>2</sub> and N<sub>2</sub> increased with the addition of the Pd/Ag layer, with the exception of the 0.74 micron TPX membrane. Although the H<sub>2</sub>/CO<sub>2</sub> selectivity increases at room temperature, the H<sub>2</sub>/N<sub>2</sub> selectivity decreases. However, at 80°C, the selectivity increases. This behavior is unexpected, as both TPX and Pd/Ag are H<sub>2</sub> selective.

Another anomolous result is that the H<sub>2</sub>/N<sub>2</sub> selectivity increases with increasing temperature for wick-coated membranes, but decreases substantially for dip-coated membranes, even though the permeation rates for the two types are about the same. Normally the selectivity of polymer membranes decreases with increasing temperature, while the selectivity of metal layers increases with increasing temperature. The decrease in selectivity in response to an increase in temperature observed in our dip coated membranes indicates that we are not obtaining the full effect of the Pd/Ag layer, even after long sputtering times which would presumably form thick Pd/Ag layers. It seems that for TPX membranes, wick coating produces better results than dip coating.

Table 4. Permeation Rates and Selectivities for PSf/SR/TPX-Pd/Ag-SR Membranes

Thickness (micron)	Sputter time (min)	SR coating method	Temp. (°C)	Permeating rate [cm <sup>3</sup> (STP)/cm <sup>2</sup> sec·cmHg]			Selectivity	
				CO <sub>2</sub>	N <sub>2</sub>	H <sub>2</sub>	α <sub>H<sub>2</sub>/CO<sub>2</sub></sub>	α <sub>H<sub>2</sub>/N<sub>2</sub></sub>
0.74	0	D	20	1.5x10 <sup>-4</sup>	1.2x10 <sup>-5</sup>	1.2x10 <sup>-4</sup>	0.8	10
			80	3.2x10 <sup>-4</sup>	5.5x10 <sup>-5</sup>	3.2x10 <sup>-4</sup>	1.0	5.8
0.74	2	W	20	8.6x10 <sup>-6</sup>	6.7x10 <sup>-6</sup>	3.8x10 <sup>-5</sup>	4.4	5.7
			80	1.8x10 <sup>-5</sup>	5.2x10 <sup>-6</sup>	1.0x10 <sup>-4</sup>	5.6	19
1.8	2	W	20	2.8x10 <sup>-7</sup>	1.8x10 <sup>-7</sup>	1.3x10 <sup>-5</sup>	46	72
			80	1.2x10 <sup>-5</sup>	7.7x10 <sup>-7</sup>	6.7x10 <sup>-5</sup>	5.6	87
3.8	2	W	20	1.2x10 <sup>-6</sup>	1.6x10 <sup>-7</sup>	7.0x10 <sup>-6</sup>	5.8	44
			80	7.4x10 <sup>-6</sup>	6.3x10 <sup>-7</sup>	4.9x10 <sup>-5</sup>	5.6	78
3.2	2	D	20	7.9x10 <sup>-6</sup>	3.2x10 <sup>-7</sup>	1.5x10 <sup>-5</sup>	1.9	47
			80	2.3x10 <sup>-5</sup>	2.4x10 <sup>-6</sup>	5.1x10 <sup>-5</sup>	2.2	21
0.74	10	D	20	2.3x10 <sup>-5</sup>	8.7x10 <sup>-7</sup>	3.5x10 <sup>-5</sup>	1.5	40
			80	9.9x10 <sup>-5</sup>	1.1x10 <sup>-5</sup>	1.3x10 <sup>-4</sup>	1.3	12
0.63	20	D	20	1.1x10 <sup>-5</sup>	5.5x10 <sup>-7</sup>	2.7x10 <sup>-5</sup>	2.5	49
			80	4.2x10 <sup>-5</sup>	4.2x10 <sup>-6</sup>	1.0x10 <sup>-4</sup>	2.4	24

W = Wick coating  
D = Dip coating

## PSf/SR/EC SUPPORT

A PSf/SR support dip coated with ethylcellulose (EC) was sputtered for three different sputter times. The permeation rates and selectivities are given in Table 5. As shown, both the uncoated support and the two minute membrane are more selective for CO<sub>2</sub> than H<sub>2</sub>. But after the five and ten minute sputter times, the Pd/Ag layer begins to take effect and H<sub>2</sub> becomes more permeable than CO<sub>2</sub>. Although the selectivity of these membranes increased with increasing sputter time, the results were not good enough to encourage further work, especially since the selectivity decreases with temperature.

Table 5. Permeation Rates and Selectivities  
for PSf/SR/EC-Pd/Ag-SR Membranes

Sputter Time (min)	Temp. (°C)	Permeation Rate [cm <sup>3</sup> (STP)/cm <sup>2</sup> sec·cmHg]			Selectivity	
		CO <sub>2</sub>	N <sub>2</sub>	H <sub>2</sub>	α <sub>H<sub>2</sub>/CO<sub>2</sub></sub>	α <sub>H<sub>2</sub>/N<sub>2</sub></sub>
0	20	8.1x10 <sup>-5</sup>	5.5x10 <sup>-6</sup>	5.5x10 <sup>-5</sup>	0.68	10
2	20	1.5x10 <sup>-5</sup>	8.8x10 <sup>-7</sup>	1.2x10 <sup>-5</sup>	0.80	14
5	20	9.4x10 <sup>-6</sup>	6.0x10 <sup>-7</sup>	1.1x10 <sup>-5</sup>	1.2	18
	80	1.9x10 <sup>-5</sup>	2.2x10 <sup>-6</sup>	2.7x10 <sup>-5</sup>	1.4	12
10	20	9.7x10 <sup>-6</sup>	6.0x10 <sup>-7</sup>	1.3x10 <sup>-5</sup>	1.3	22
	80	2.1x10 <sup>-5</sup>	2.2x10 <sup>-6</sup>	3.3x10 <sup>-5</sup>	1.6	15

## PEI-1 SUPPORT

The PEI-1 support sputtered with Pd and Pd/Ag exhibited lower selectivities than the uncoated PEI-1. This could be due to the formation of defects in the support caused by the sputtering process. The resulting permeation rates and selectivities can be found in Appendix B. An explanation for the decrease in selectivity is that the sputter plasma created pinholes in the PEI-1 support. The PEI-1-Pd/Ag membranes were therefore coated with silicone rubber and the results are presented in Table 6. The silicone rubber sealing layer reduced the N<sub>2</sub> permeation rate by approximately 50 times as compared to the PEI-1-Pd membranes, while the H<sub>2</sub> permeation rate stayed relatively the same. As a result, very high H<sub>2</sub>/N<sub>2</sub> selectivities were obtained for sputter times of 0.25, 1 and 2 minutes. Although the H<sub>2</sub>/N<sub>2</sub> selectivities increased dramatically, the H<sub>2</sub>/CO<sub>2</sub> selectivities showed only a marginal increase.

The effect of the Pd/Ag layer can be seen when the membranes are tested at the higher temperature. The permeation rates and selectivities increase with temperature, a behavior typical of metal membranes.

Table 6. Permeation Rates and Selectivities  
for PEI-1-Pd/Ag-SR Membranes

Sputter Time (min)	Temp. (°C)	Permeation Rate [cm <sup>3</sup> (STP)/cm <sup>2</sup> sec·cmHg]			Selectivity	
		CO <sub>2</sub>	N <sub>2</sub>	H <sub>2</sub>	α <sub>H<sub>2</sub>/CO<sub>2</sub></sub>	α <sub>H<sub>2</sub>/N<sub>2</sub></sub>
0	20	3.4x10 <sup>-5</sup>	1.9x10 <sup>-5</sup>	1.7x10 <sup>-4</sup>	5.0	8.9
0.25	20	3.8x10 <sup>-6</sup>	5.6x10 <sup>-7</sup>	2.9x10 <sup>-5</sup>	7.6	52
	80	1.1x10 <sup>-5</sup>	4.5x10 <sup>-7</sup>	1.2x10 <sup>-4</sup>	11	267
1	20	1.3x10 <sup>-6</sup>	4.5x10 <sup>-8</sup>	2.4x10 <sup>-5</sup>	19	533
	80	7.0x10 <sup>-6</sup>	1.1x10 <sup>-7</sup>	6.1x10 <sup>-5</sup>	8.7	555
2	20	1.0x10 <sup>-6</sup>	2.6x10 <sup>-7</sup>	9.1x10 <sup>-6</sup>	9.1	35
	80	6.2x10 <sup>-6</sup>	2.3x10 <sup>-7</sup>	8.6x10 <sup>-5</sup>	14	374
3	20	2.1x10 <sup>-6</sup>	---	1.0x10 <sup>-5</sup>	4.8	---
	80	4.7x10 <sup>-6</sup>	3.0x10 <sup>-6</sup>	9.3x10 <sup>-5</sup>	20	31
5	20	2.4x10 <sup>-6</sup>	2.9x10 <sup>-7</sup>	1.3x10 <sup>-5</sup>	5.4	45

---N<sub>2</sub> flux not measurable

#### PEI-1/SR SUPPORT

Previous results from single layer membranes indicated that the PEI-1 supports were not as tight as we had originally believed. Therefore, the PEI-1 supports were sealed with a thin layer of silicone rubber before sputtering. The selectivities for the PEI-1/SR-Pd/Ag as well as the PEI-1/SR-Pd/Ag-SR membranes are presented in Table 7.

Table 7. PEI-1/SR-Pd/Ag and PEI-1/SR-Pd/Ag-SR  
Multicomposite Membranes

Sputter time (min)	Temp. (°C)	Permeation rate [cm <sup>3</sup> (STP)/cm <sup>2</sup> sec·cmHg]			Selectivity	
		CO <sub>2</sub>	N <sub>2</sub>	H <sub>2</sub>	$\alpha_{H_2/CO_2}$	$\alpha_{H_2/N_2}$
<u>PEI-1/SR-Pd/Ag</u>						
0	20	2.4x10 <sup>-5</sup>	5.3x10 <sup>-7</sup>	1.0x10 <sup>-4</sup>	4.2	189
1	20	6.9x10 <sup>-6</sup>	1.0x10 <sup>-7</sup>	1.5x10 <sup>-5</sup>	2.2	150
	80	9.3x10 <sup>-6</sup>	3.7x10 <sup>-7</sup>	6.9x10 <sup>-5</sup>	7.4	186
2	20	3.3x10 <sup>-6</sup>	4.6x10 <sup>-8</sup>	9.0x10 <sup>-6</sup>	2.7	196
	80	5.9x10 <sup>-6</sup>	3.2x10 <sup>-7</sup>	6.0x10 <sup>-5</sup>	10	188
5	20	1.7x10 <sup>-6</sup>	2.0x10 <sup>-8</sup>	5.3x10 <sup>-6</sup>	3.1	265
10	20	9.0x10 <sup>-7</sup>	1.5x10 <sup>-8</sup>	4.6x10 <sup>-6</sup>	5.1	307
<u>PEI-1/SR-Pd/Ag-SR</u>						
1	20	4.4x10 <sup>-6</sup>	1.8x10 <sup>-7</sup>	1.3x10 <sup>-5</sup>	3.0	72
	80	1.0x10 <sup>-5</sup>	3.8x10 <sup>-7</sup>	9.3x10 <sup>-5</sup>	9.3	245
2	20	1.5x10 <sup>-6</sup>	1.8x10 <sup>-8</sup>	1.3x10 <sup>-5</sup>	8.7	722
	80	4.2x10 <sup>-6</sup>	1.3x10 <sup>-7</sup>	5.3x10 <sup>-5</sup>	13	408
5	20	2.4x10 <sup>-6</sup>	8.7x10 <sup>-7</sup>	7.4x10 <sup>-6</sup>	3.1	8.5
10	20	1.4x10 <sup>-6</sup>	3.6x10 <sup>-8</sup>	9.2x10 <sup>-6</sup>	6.6	256
	80	1.5x10 <sup>-5</sup>	5.0x10 <sup>-7</sup>	7.0x10 <sup>-5</sup>	4.7	140

The table shows that the H<sub>2</sub>/N<sub>2</sub> selectivity is quite high for the coated PEI-1/SR support itself. This suggests that it might be the intrinsic selectivity of a tight PEI-1 membrane. Although the H<sub>2</sub>/CO<sub>2</sub> selectivity increases with temperature, the H<sub>2</sub>/N<sub>2</sub> selectivity decreases. This indicates that the polymer membrane is affecting the separation, not the Pd/Ag layer. It is interesting to note that the selectivities are increasing with increased sputter time. The Pd/Ag layer shows some effect on the H<sub>2</sub>/N<sub>2</sub> selectivity for the PEI-1 supports, although not to the extent it did for the PSf/SR supports. The PSf/SR-Pd/Ag-SR membranes in Table 4 show a substantial increase in H<sub>2</sub>/N<sub>2</sub> selectivity of the sputtered membranes over the unsputtered support. This selectivity is not inherent in either the silicone rubber or the PSf.

## PEI-1/TPX SUPPORT

PEI-1 supports were dip coated in TPX before sputtering. Each PEI-1/TPX support was tested before and after sputtering in order to provide a reference for each Pd/Ag membrane. The permeation rates and selectivities are given in Table 8. The results show that the PEI-1/TPX unsputtered supports have higher selectivities and permeation rates than the sputtered supports. It seems that the sputter plasma may be damaging the TPX layer. The polymer layers are still controlling the permeation of gases through the membrane.

Table 8. Permeation Rates and Selectivities  
for PEI-1/TPX-Pd/Ag-SR Membranes

Sputter Time (min)	Temp. (°C)	Permeation Rate [cm <sup>3</sup> (STP)/cm <sup>2</sup> sec·cmHg]			Selectivity	
		CO <sub>2</sub>	N <sub>2</sub>	H <sub>2</sub>	α <sub>H<sub>2</sub>/CO<sub>2</sub></sub>	α <sub>H<sub>2</sub>/N<sub>2</sub></sub>
0	20	1.9x10 <sup>-5</sup>	7.4x10 <sup>-7</sup>	7.2x10 <sup>-5</sup>	3.8	97
2	20	8.6x10 <sup>-6</sup>	2.8x10 <sup>-7</sup>	2.3x10 <sup>-5</sup>	2.7	82
0	20	1.7x10 <sup>-5</sup>	6.7x10 <sup>-7</sup>	5.1x10 <sup>-5</sup>	3.0	76
5	20	4.4x10 <sup>-6</sup>	2.2x10 <sup>-7</sup>	1.1x10 <sup>-5</sup>	2.5	50
0	20	1.6x10 <sup>-5</sup>	7.8x10 <sup>-7</sup>	4.2x10 <sup>-5</sup>	2.6	54
10	20	5.2x10 <sup>-6</sup>	2.9x10 <sup>-7</sup>	1.3x10 <sup>-5</sup>	2.5	45
	80	1.4x10 <sup>-5</sup>	1.4x10 <sup>-6</sup>	4.4x10 <sup>-5</sup>	3.1	31

## SCANNING ELECTRON MICROSCOPY

The structure of a number of membranes was examined using a Scanning Electron Microscope (SEM). The electron micrographs were taken after the membranes had been tested for their gas permeability. Figures 11 to 15 are a selection of the pictures taken and show some typical membrane surface structures including defects.

Figure 11 is a micrograph of a palladium layer covering a dust particle. The crack, formed along the edge of the particle, is due to the pressure of the test gases molding the palladium layer over the dust particles. The crack is significant in that gases can easily flow through the opening in the selective layer. Figure 12 is an example of a defect found on the surface of many membranes. The cracks in the hole, which are approximately 0.2 to 0.4 microns in diameter, are large enough to allow bulk flow of gases through the membranes. The hole is the result of high pressure pushing the thin layer of palladium into a defect in the support.



4  $\mu\text{m}$

Figure 11. PSf/SR-Pd: 6 minute sputter time; 5,000x magnification.



20  $\mu\text{m}$

Figure 12. PEI-2-Pd: 2 minute sputter time; 1,000x magnification.

Figures 13 and 14 are pictures of the surface of PSf/SR and PEI-1 membranes. The PSf/SR membranes have many grooves and indentations on the surface. The PEI-1 surface, on the other hand, is very smooth and continuous; a good surface onto which the Pd/Ag layer is deposited. Figure 15 is a cross-section of a silicone rubber coated PEI-1 support with a very thin layer of Pd/Ag.

The composition of the palladium-silver layer of one membrane was determined using an Electron Spectroscopy (ESCA) method. The analysis showed the composition to be 78 wt% palladium and 22 wt% silver. This result agrees very well with the composition of the palladium-silver source (76 wt% palladium and 24 wt% silver).

#### COMPARISON OF THE BEST PALLADIUM/SILVER MEMBRANES WITH POLYMERIC MEMBRANES

In this section we will compare the performance of the Pd/Ag composite membranes with the best commercially available membrane reported in the literature, the Monsanto Prism membrane<sup>(13)</sup>, and the best membranes that might be made from polymers of known permeability<sup>(14)</sup>.

As the basis of our comparison we first assume that it is possible to formulate known membrane materials into membranes with an effective thickness of one micron. This has been achieved and even surpassed with a few materials, but would be difficult with others. The flux of membranes made from each polymer is then plotted vs. membrane selectivity for the gas mixture  $H_2/N_2$ . The graph is shown in Figure 16. The performance of the Monsanto Prism membrane and the best Pd/Ag membranes made in this feasibility program are also plotted on these graphs.

From these plots it is clear that the best Pd/Ag membranes are significantly better than other membranes for the separation of  $H_2/N_2$ , with selectivities almost 10-fold higher than conventional polymer membranes with the same flux. The membranes also have higher fluxes, by 50 to 100%, and higher selectivities, by 10- to 20-fold, than the Monsanto Prism membranes, the current leader in hydrogen gas separation membranes.

Since  $CH_4$  and CO permeate through membranes at approximately the same rate as  $N_2$ , the Pd/Ag composite membranes will be equally superior for  $H_2/CH_4$  and  $H_2/CO$  separations, with selectivities well over 100. The  $H_2/CO_2$  selectivity of the Pd/Ag membranes is low compared to their  $H_2/N_2$  selectivity. However, an  $H_2/CO_2$  selectivity larger than 20 is very exceptional for membranes. In fact, only three polymer materials are known to have an  $H_2/CO_2$  selectivity larger than 10<sup>(14)</sup>. These materials

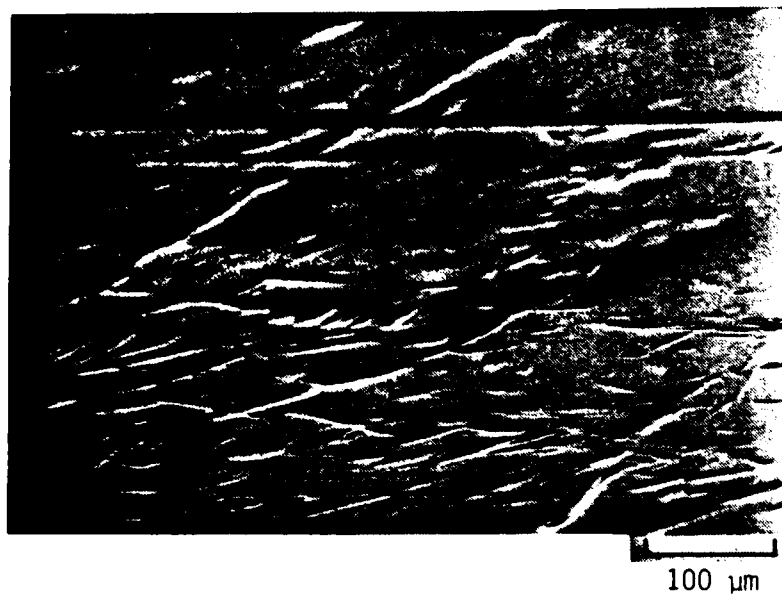

Figure 13. PSf/SR-Pd: 10 minute sputter time;  
200x magnification.

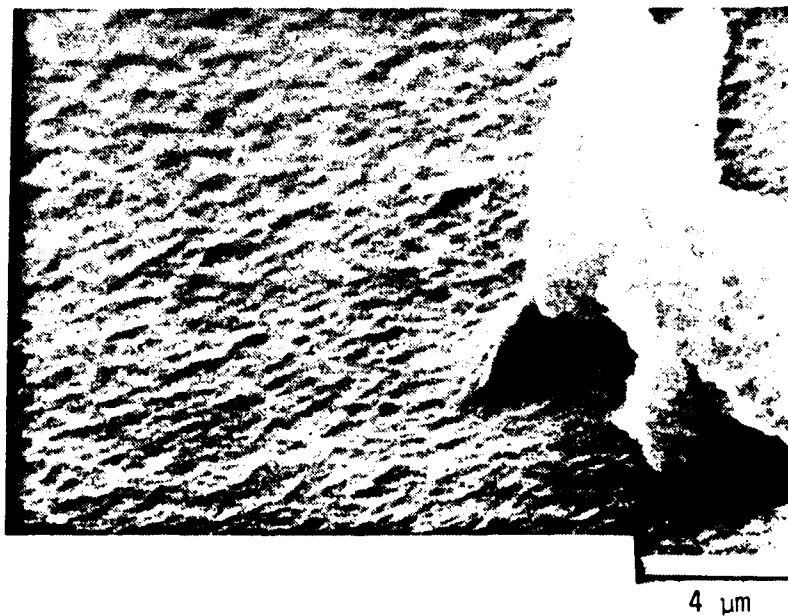

Figure 14. PEI-1/SR-Pd/Ag: 30 minute sputter time;  
5,000x magnification.



Figure 15. PEI-1/SR-Pd/Ag: 30 minute sputter time; 1,000x magnification.

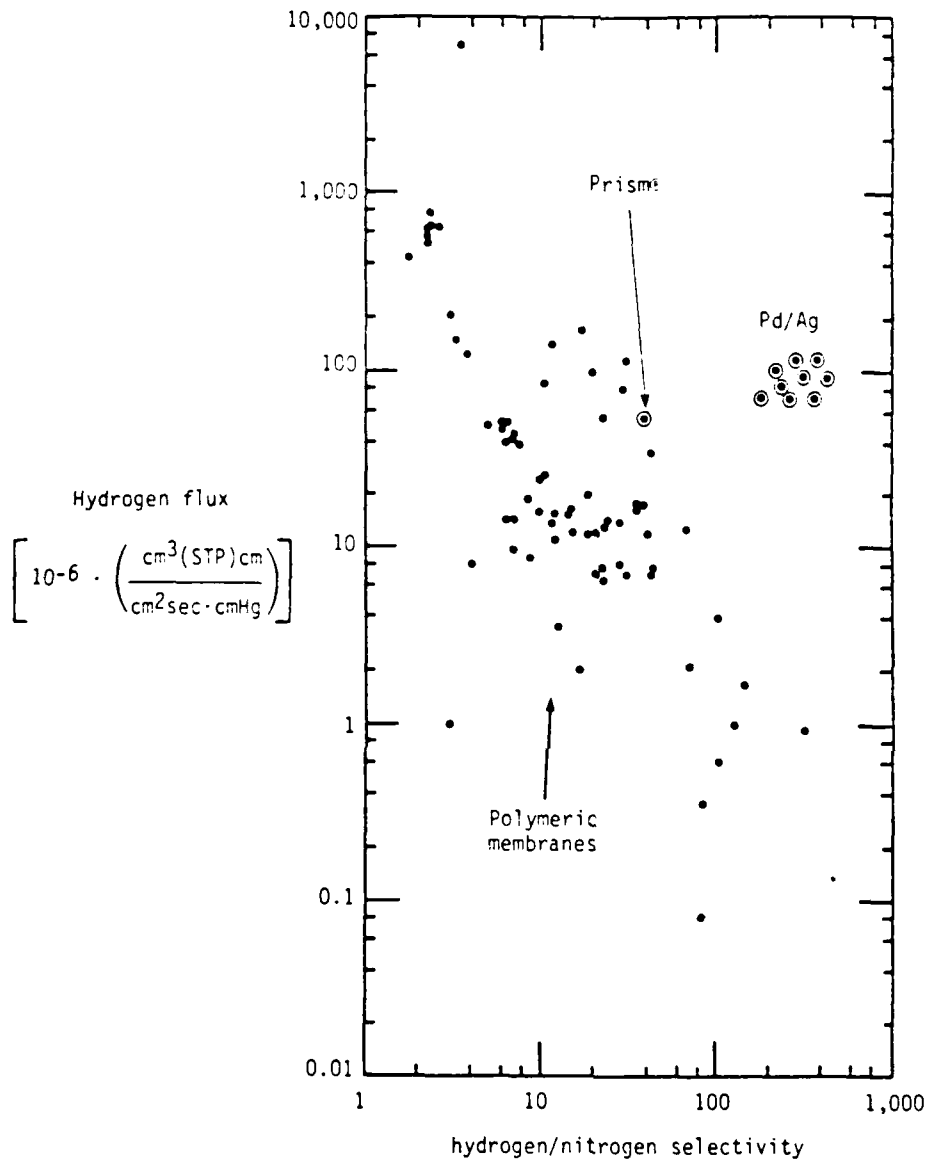

Figure 16. Normalized H<sub>2</sub> flux *vs.* H<sub>2</sub>/N<sub>2</sub> selectivity for polymeric membranes, Monsanto's commercially available Prism<sup>®</sup> membrane, and the best Pd/Ag membranes produced in this program.

are barrier materials with very low fluxes: their H<sub>2</sub> permeation rate through a one-micron-thick layer is on the order of 10<sup>-6</sup> cm<sup>3</sup>(STP)/cm<sup>2</sup>·sec·cmHg. The best Pd/Ag membranes prepared combine a higher H<sub>2</sub> permeation rate with H<sub>2</sub>/CO<sub>2</sub> selectivities larger than 20.

#### CONCLUSIONS

This feasibility program has clearly demonstrated that superior membranes can be made by the thin film composite technique. Our best membranes had selectivities higher by an order of magnitude than comparable polymer membranes. On the other hand, membrane reproducibility is a problem that remains to be solved.

## REFERENCES

1. E.J. Daniels, B.D. Yudow, and T.D. Donakowski, "USAF Advanced Terrestrial Energy Study, Vol. I," AD-A133803 (April, 1983).
2. D. Cameron, "Fuel Cell Energy Generators," CHEMTECH 9, 633 (1979).
3. R. Henry, "Hydrogen Generator Subsystem," AD-A068452 (November 1978).
4. J.M.S. Henis and M.K. Tripodi, "A Novel Approach to Gas Separation Using Composite Hollow Fiber Membranes," Sep. Sci. & Tech. 15, 1059 (1980).
5. W.J. Schell and S.D. Houston, "Membrane Gas Separations for Chemical Processes and Energy Applications," in Industrial Gas Separations, T.E. Whyte, Jr., C.M. Yon, and E.H. Wagner (eds.), ACS Symposium Series 223, American Chemical Society, Washington, D.C. (1983).
6. V.T. Stannett, W.J. Koros, D.R. Paul, H.K. Lonsdale, and R.W. Baker, "Recent Advances in Membrane Science and Technology," Adv. Poly. Sci. 32, 69 (1979)
7. S.T. Hwang and K. Kammermeyer, Membranes in Separations, Wiley Interscience, New York (1975).
8. F.J. Norton, "Permeation of Gases through Solids," J. Appl. Physics 28, 34 (1957).
9. K. Kammermeyer, "Technical Gas Permeation Processes," Chem-Ing-Tech 48, 672 (1976).
10. R.B. McBride and D.L. McKinley, Chem. Eng. Prog. 61, 81 (1965).
11. J.B. Hunter, U.S. Patent 2,773,561, (December 1956).
12. D. Mercea, L. Muresan, and V. Mecea, "Permeation of Gases Through Metallized Polymer Membranes," J. Memb. Sci. 24, 297 (1985).
13. J.M.S. Henis and M.K. Tripodi, U.S. Patent 4,320,463, "Multicomponent Membranes for Gas Separations."
14. I. Blume, MTR Report, 1986.

APPENDIX A

PSf/SR SUPPORT MEMBRANES

PSf/SR Support Coated with Pd and Pd/Ag.

The PSf/SR support was sputtered at eight different sputter times with Pd and three with Pd/Ag. PSf/SR was also sputtered at four sputter times using the pulse mode. The results are presented in Table A-1 and Figures A-1 and A-2. The pulse mode allows for the intermittent pulsing of the plasma in order to provide finer layers of metal on the surface of the membrane. We had hoped that the intermittent deposition of the Pd would provide for a more even distribution of the Pd in a continuous layer across the surface of the membrane.

Table A-1. Selectivities of PSf/SR Support Membranes

Membrane Selectivity	Sputter Time (min)						
	0	2	4	6	8	10	14
<u>PSf/SR-Pd</u>							
$\alpha_{H_2/CH_4}$	1.0	3.4	7.6	17.1	2.6	3.2	2.8
$\alpha_{H_2/CO_2}$	0.3	3.4	7.2	17.9	2.6	1.0	3.3
$\alpha_{H_2/O_2}$	1.4	4.7	4.3	24.1	3.4	3.9	3.7
$\alpha_{H_2/N_2}$	3.2	6.5	3.9	22.6	3.7	5.9	3.7
<u>PSf/SR-Pd with pulse</u>							
$\alpha_{H_2/CH_4}$	1.0	---	2.9	2.9	2.8	2.4	---
$\alpha_{H_2/CO_2}$	0.3	---	3.2	3.0	2.9	2.7	---
$\alpha_{H_2/O_2}$	1.4	---	3.9	4.1	3.7	3.4	---
$\alpha_{H_2/N_2}$	3.2	---	4.7	4.2	4.7	3.5	---
<u>PSf/SR-Pd/Ag</u>							
$\alpha_{H_2/N_2}$	3.2	5.6	4.9	---	---	4.4	---

It can be seen from Table A-1 that the selectivity increased slightly due to the deposition of a metal layer on top, but the increase is insignificant compared to the results expected from a palladium layer. The table also shows that the sputtered metal is not very selective for hydrogen over the other gases. We seemed to attain a slightly better selectivity at the 6 minute sputter time, but not enough to give a  $H_2$  separation of 99% or better. Neither the pulse mode nor the Pd/Ag layer seemed to improve the selectivity. The selectivity is essentially the same for all three membranes with the exception of the 6 minute PSf/SR-Pd membrane.

Figures A-1 and A-2 are graphs of the permeation rate versus sputter time for the PSf/SR-Pd membrane. Contrary to our expectations that the flux, and therefore the permeation rate, would decrease with increasing sputter time, the values seemed to rise and fall randomly as the sputter time (thickness of the Pd layer) increased. The selectivity of H<sub>2</sub> to the other gases showed the same behavior. We would expect that the flux would decrease with increasing thickness of the palladium coating and that, as a result, the selectivity for H<sub>2</sub> would increase over that of any of the other gases. We found our results difficult to explain since the fluxes are lowered by a factor of 100, but the selectivity increases only moderately.

#### PSf/SR-Pd/Ag-SR-Pd/Ag Multicomposite Membranes

A 1+1 membrane is composed of a PSf/SR support sputtered for one minute, wick coated with SR and sputtered again for one minute. The permeation rates and selectivities for these membranes are presented in Table A-2. These membranes seem to have slightly higher selectivities than the single layer membranes.

The selectivities are higher at the lower sputtering times, but still not as high as would be expected from the sealing of the defects. Although the selectivities were lower than anticipated, especially at the longer sputtering times, the results were encouraging. We decided to try to reproduce the results of the 1+1 minute membrane, but this time dip coated it with silicone rubber for both SR layers.

Table A-2. Permeation Rates and Selectivities for PSf/SR-Pd/Ag-SR-Pd/Ag Membranes

Sputter Time (min)	Permeation Rate [cm <sup>3</sup> (STP)/cm <sup>2</sup> sec·cmHg]			Selectivity	
	CO <sub>2</sub>	N <sub>2</sub>	H <sub>2</sub>	α <sub>H<sub>2</sub>/CO<sub>2</sub></sub>	α <sub>H<sub>2</sub>/N<sub>2</sub></sub>
<u>PSf/SR-Pd/Ag-SR-Pd/Ag</u>					
1+1	2.4x10 <sup>-6</sup>	3.9x10 <sup>-7</sup>	7.8x10 <sup>-6</sup>	3.3	20
3+3	3.3x10 <sup>-6</sup>	2.3x10 <sup>-6</sup>	1.2x10 <sup>-5</sup>	3.6	5.2
5+5	1.8x10 <sup>-6</sup>	9.0x10 <sup>-7</sup>	8.0x10 <sup>-6</sup>	4.4	8.9
<u>PSf/SR-Pd/Ag-SR-Pd/Ag (dipped)</u>					
1+1	9.3x10 <sup>-7</sup>	1.4x10 <sup>-8</sup>	3.4x10 <sup>-6</sup>	3.7	243

The N<sub>2</sub> permeation rate decreased almost 30 times when the dip coating method was used. We speculate that the reason for this is that the initial Pd/Ag layer was scratched by the action of the sponge passing over the surface. In dipping, there is no abrasive contact with the Pd/Ag layer and therefore the layer is left relatively intact and continuous. Dip coating should therefore be the preferred method for membrane preparation.

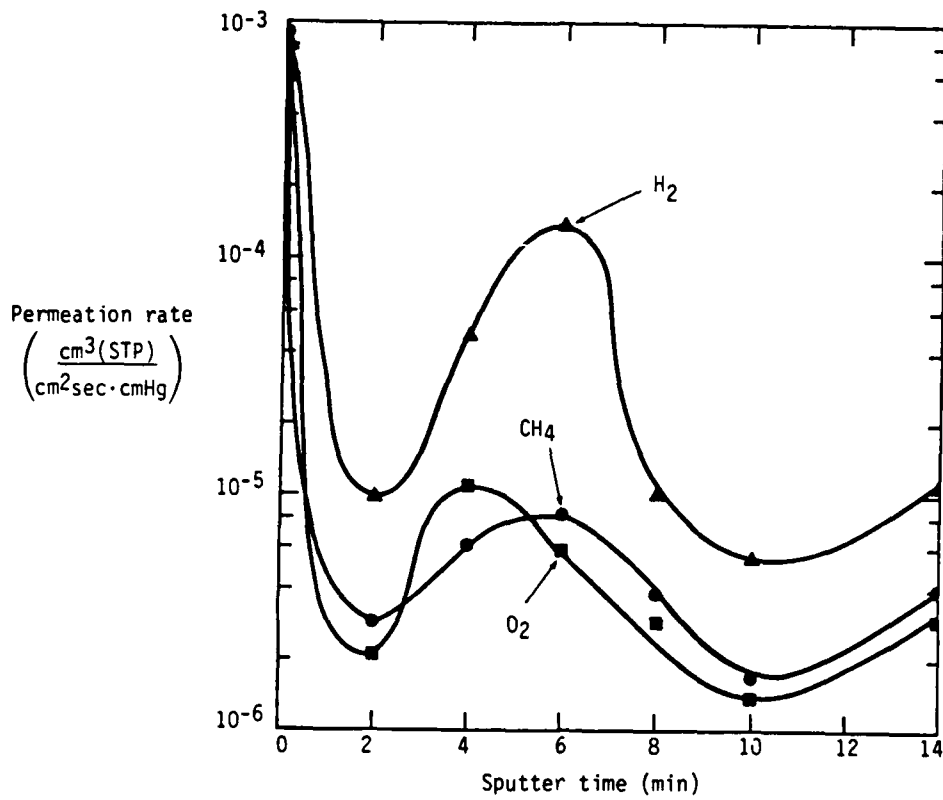

Figure A-1. PSf/SR coated with Pd.

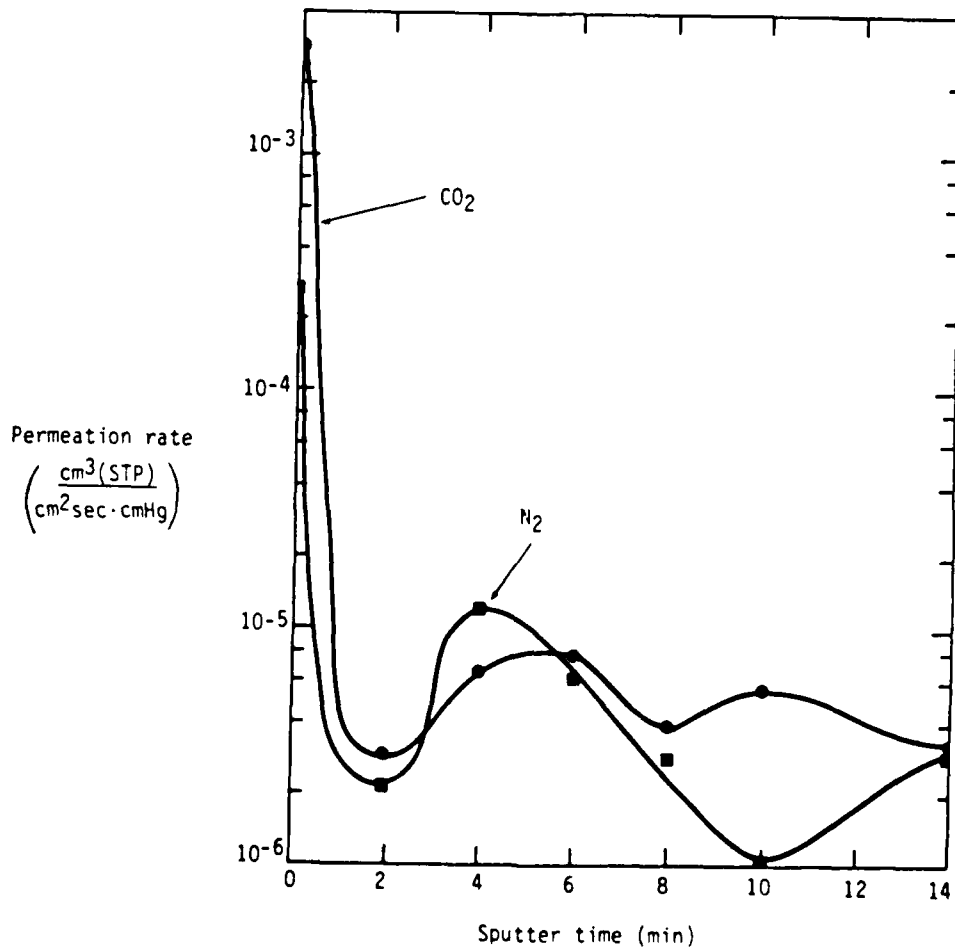

Figure A-2. PSf/SR coated with Pd.

## APPENDIX B

### PEI-1 SUPPORT MEMBRANES

#### PEI-1 support coated with Pd and Pd/Ag

PEI-1 is a tight membrane, i.e., theoretically it has no pores and should allow only diffusion of gases rather than convection of gases. In this case, one would expect the smallest molecules to diffuse faster than the larger or bulkier molecules. Figure B-1 is a graph of the results obtained from testing the PEI-1-Pd membranes. Since there were few differences between the Pd and Pd/Ag coated PEI-1, the data for the PEI-1-Pd membranes is used to describe both.

The uncoated PEI-1 support had slightly lower gas permeation rates than the uncoated PSf/SR support. The addition of the Pd layer did not lower the permeation rates by much and the PEI-1-Pd membranes seemed to exhibit the same behavior as the PSf/SR-Pd membranes, in that the permeation rate fluctuates as the sputter time increases. One would expect that since the PEI-1 support has no pores, the palladium layer would be continuous and therefore lower the flux of all gases as sputter time increases. But Figure B-1 shows that this is not so.

The selectivity of this membrane did not increase with the deposition of the palladium on the surface; on the contrary, it actually decreases. Part of the problem is that the PEI-1 material seems to have a slight static charge that attracts dust particles. The dust particles on the surface of the support give rise to a discontinuous layer of palladium which in turn lowers the selectivity. Another problem is the support itself. Different stamps of the same membrane material, from the same source, may vary in permeation rates and selectivities. This could be the explanation of the inconsistent results.

#### PEI-1-Pd/Ag-SR-Pd/Ag membranes

These PEI-1 multicomposite membranes consist of a silicone rubber layer sandwiched between two Pd/Ag layers. Table B-1 lists the results obtained from wick and dip coating the silicone rubber layer on the multicomposite membranes.

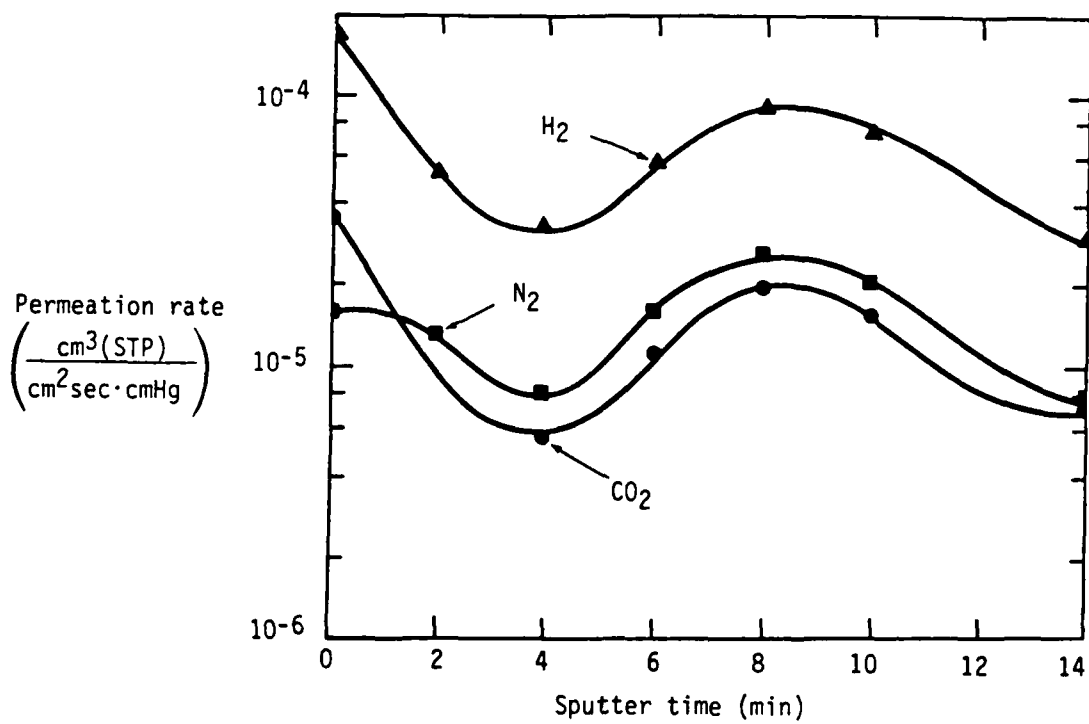

Figure B-1. PEI-1 coated with Pd.

Table B-1. PEI-1-Pd/Ag-SR-Pd/Ag Multilayer Composite Membranes

Sputter Time (min)	Permeation Rate [cm <sup>3</sup> (STP)/cm <sup>2</sup> sec·cmHg]			Selectivity	
	CO <sub>2</sub>	N <sub>2</sub>	H <sub>2</sub>	$\alpha_{H_2/CO_2}$	$\alpha_{H_2/N_2}$
<u>PEI-1-Pd/Ag-SR-Pd/Ag</u>					
1+1	1.0x10 <sup>-6</sup>	1.5x10 <sup>-7</sup>	6.3x10 <sup>-6</sup>	6.3	42
3+3	1.0x10 <sup>-6</sup>	2.0x10 <sup>-7</sup>	5.6x10 <sup>-6</sup>	5.6	28
5+5	3.4x10 <sup>-6</sup>	4.0x10 <sup>-6</sup>	1.6x10 <sup>-5</sup>	4.7	4.0
<u>PEI-1-Pd/Ag-SR-Pd/Ag (dipped)</u>					
1+1	9.3x10 <sup>-7</sup>	2.3x10 <sup>-8</sup>	4.1x10 <sup>-6</sup>	4.4	178

The addition of the second Pd/Ag layer lowered the permeation rates 10-fold compared to the permeation rates through the PEI-1-Pd membranes. Although the H<sub>2</sub>/CO<sub>2</sub> selectivity remained the same, the H<sub>2</sub>/N<sub>2</sub> selectivity increased about 10 times. This would put the H<sub>2</sub>/N<sub>2</sub> selectivity within the range of the intrinsic selectivity of the PEI-1 support. This indicates that the Pd/Ag-SR-Pd/Ag layer served only to coat the pores in the PEI-1 support.

However, as with the PSf/SR-Pd/Ag-SR-Pd/Ag membrane, the dipped silicone rubber layer was instrumental in lowering the N<sub>2</sub> permeability and therefore increasing the H<sub>2</sub>/N<sub>2</sub> selectivity. Again, the H<sub>2</sub>/CO<sub>2</sub> selectivity remained unchanged.

END

12-86

DTIC