

AD-A174 725

EVALUATION OF CAPEL (CONFINED ARMATURE PROJECTILE
EXPERIMENTAL LAUNCHER) A NOVEL RAILGUN CONCEPT(U)
MATERIALS RESEARCH LABS ASCOT VALE (AUSTRALIA)

1/1

UNCLASSIFIED

G A CLARK SEP 86 MRL-R-1018

F/G 19/6

NL

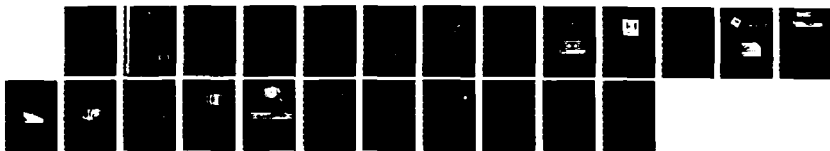

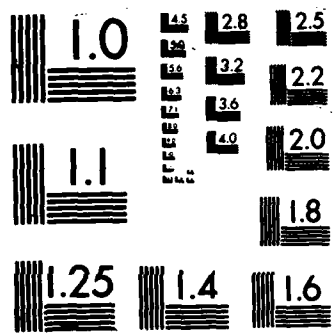

MICROCOPY RESOLUTION TEST CHART

12



DEPARTMENT OF DEFENCE
DEFENCE SCIENCE AND TECHNOLOGY ORGANISATION
MATERIALS RESEARCH LABORATORIES
MELBOURNE, VICTORIA

REPORT

MRL-R-1018

AD-A174 725

EVALUATION OF CAPEL, A NOVEL RAILGUN CONCEPT

G.A. Clark

THE UNITED STATES NATIONAL
TECHNICAL INFORMATION SERVICE
IS AUTHORISED TO
REPRODUCE AND SELL THIS REPORT

SDTIC
ELECTE
DEC 03 1986
E

Approved for Public Release

NTIC FILE COPY



C Commonwealth of Australia
SEPTEMBER 1986

86 12 03 031

DEPARTMENT OF DEFENCE
MATERIALS RESEARCH LABORATORIES

REPORT

MRL-R-1018

EVALUATION OF CAPEL, A NOVEL RAILGUN CONCEPT

G.A. Clark

ABSTRACT

Results are presented from preliminary testing and a successful low velocity projectile launch from a novel electromagnetic launcher using a plasma armature. The design concept of the railgun involves the containment of the plasma armature within the projectile. Design details of the launcher and projectile are presented and advantages of the concept are discussed.



Accession For	
NTIS GRA&I	<input checked="" type="checkbox"/>
DTIC TAB	<input type="checkbox"/>
Unannounced	<input type="checkbox"/>
Justification	
By _____	
Distribution/	
Availability Codes	
Dist	Avail and/or Special
A-1	

Approved for Public Release

POSTAL ADDRESS: Director, Materials Research Laboratories
P.O. Box 50, Ascot Vale, Victoria 3032, Australia

DOCUMENT CONTROL DATA SHEET

REPORT NO. MRL-R-1018	AR NO. AR-004-835	REPORT SECURITY CLASSIFICATION Unclassified
--------------------------	----------------------	--

TITLE

Evaluation of CAPEL, a novel railgun concept

AUTHOR(S) G.A. Clark	CORPORATE AUTHOR Materials Research Laboratories PO Box 50, Ascot Vale, Victoria 3032
-----------------------------	--

REPORT DATE September, 1986	TASK NO. DST 82/212	SPONSOR DSTO
--------------------------------	------------------------	-----------------

FILE NO. G6/4/8-3218	REFERENCES 12	PAGES 20
-------------------------	------------------	-------------

CLASSIFICATION/LIMITATION REVIEW DATE

CLASSIFICATION/RELEASE AUTHORITY
Superintendent, MRL
Physics Division

SECONDARY DISTRIBUTION

Approved for Public Release

ANNOUNCEMENT

Announcement of this report is unlimited

KEYWORDS

Projectiles Electric Guns	Launching Capel	Electromagnetic Compatibility
------------------------------	--------------------	-------------------------------

COSATI GROUPS	19060	636
---------------	-------	-----

ABSTRACT

Results are presented from preliminary testing and a successful low velocity projectile launch from a novel electromagnetic launcher using a plasma armature. The design concept of the railgun involves the containment of the plasma armature within the projectile. Design details of the launcher and projectile are presented and advantages of the concept are discussed.

CONTENTS

	Page No.
INTRODUCTION	1
1. DESIGN CONCEPT	1
2. EXPERIMENTAL DESIGN	3
2.1 <i>Launcher</i>	3
2.2 <i>Projectile</i>	3
3. EXPERIMENTAL RESULTS	5
3.1 <i>Firing Number One</i>	6
3.2 <i>Firing Number Two</i>	6
3.3 <i>Firing Number Three</i>	8
3.4 <i>Firing Number Four</i>	9
3.5 <i>Firing Number Five</i>	10
4. DISCUSSION	13
5. CONCLUSION	16
ACKNOWLEDGEMENTS	17
REFERENCES	18

EVALUATION OF CAPEL, A NOVEL RAILGUN CONCEPT

INTRODUCTION

This report presents the results from the testing of, and successful firing from, "CAPEL" (Confined Armature Projectile Experimental Launcher) which is believed to be an entirely new concept in railgun design. The report concentrates on the mechanical aspects of the design and is divided into 5 sections as follows: Section 1 describes the concept; Sections 2 and 3 present the experimental design and the results; Section 4, the discussion, details numerous advantages of this new design. The conclusion is presented in Section 5.

1. DESIGN CONCEPT

Since Rashleigh and Marshall [1] published their paper on the acceleration of a projectile using a railgun, almost all designs have had square or rectangular bores in which the driving plasma armature fills the immediate volume behind the projectile (Fig. 1), [2-5].

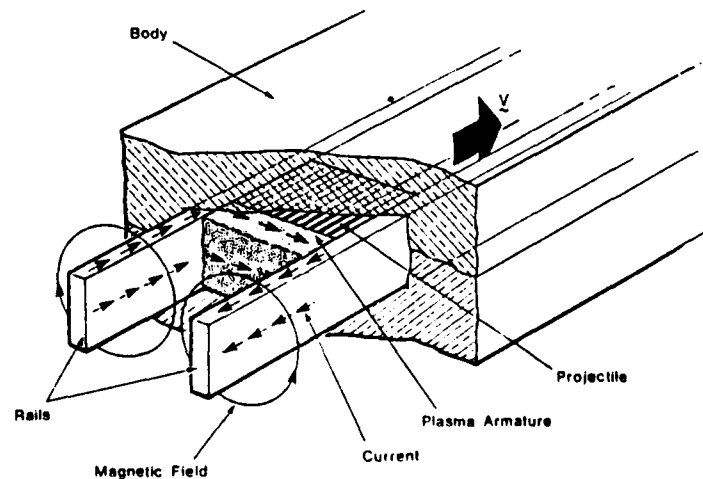

FIGURE 1 Conventional Railgun Design

The rails and the insulating side walls of the bore immediately behind the projectile confine the high pressure plasma as it accelerates the projectile forward due to the Lorentz $\underline{J} \times \underline{B}$ forces impressed through the plasma. This accelerating plasma armature occupies a discrete volume which is approximately 50 mm long for a 10 mm square bore [6]. It follows therefore that only the immediate region behind the projectile requires confining walls. Instead of using the confining, continuous walls of a barrel to contain the transverse forces of a high pressure plasma armature, a cavity is introduced into the projectile itself. This then contains the plasma (Fig. 2). This means in effect that the confining walls travel along with the projectile (Fig. 2). In this way CAPEL utilizes the unique feature of a railgun, i.e. the ability to accelerate a discrete package of plasma in one direction only.

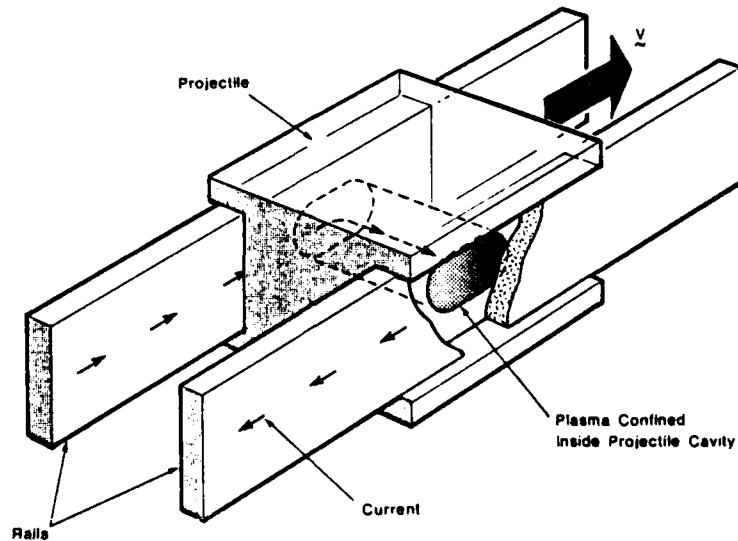

FIGURE 2 Schematic cutaway view of a new concept in railguns

In CAPEL, the plasma armature is accelerated forward against the front wall of the cavity by the $\underline{J} \times \underline{B}$ force. Confined within the cavity, the plasma transfers the force to the projectile and accelerates it along the rails. This would not be possible with a traditional chemical gun as the driving force is not uni-directional.

Thus, this design dispenses with the need for a fully confining barrel. It also provides many other advantages over the conventional railgun (using a plasma armature). These are discussed in the later sections of the report.

2. EXPERIMENTAL DESIGN

2.1 Launcher

Figure 3 shows the first prototype of CAPEL which is slightly different in design from that shown conceptually in Fig. 2. The change in design was brought about by fabrication considerations and availability of materials. The rails were manufactured from 36 mm diameter copper bars, 500 mm long, which were bolted to lengths of aluminium alloy channel.

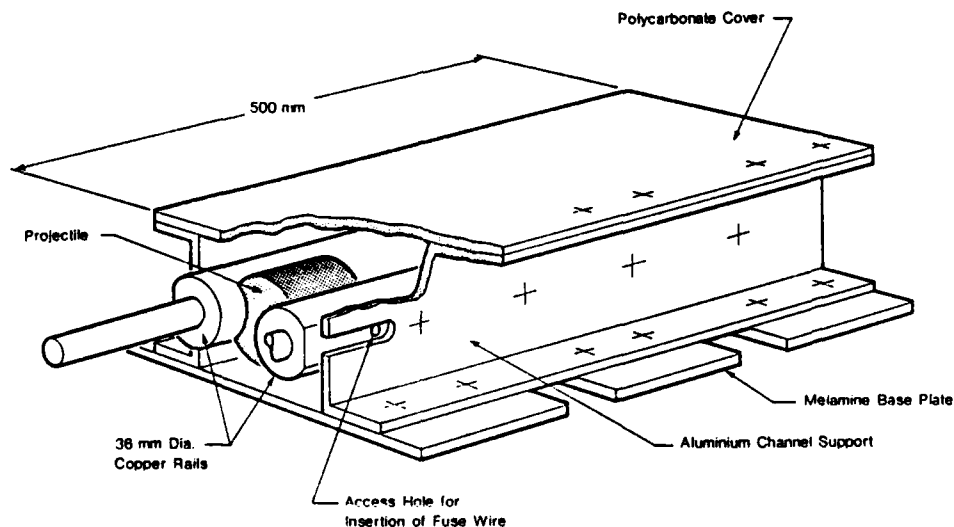

FIGURE 3 Perspective view of CAPEL

To maintain the separation between the rails the channel is bolted to melamine sleepers to give a railway track configuration. The separation between the rails was 30 mm.

In order to simplify the bracing of the rails a 10 mm thick sheet of polycarbonate was bolted and pinned to the top of the assembly. Copper rods (12.5 mm dia) were screwed tightly into the breach end for connection to the power supply.

2.2 Projectile

The projectiles were made from polycarbonate rod (50 mm dia). Polycarbonate was chosen because it is a good insulating material with high impact strength. The basic projectile design is shown in Figure 4.

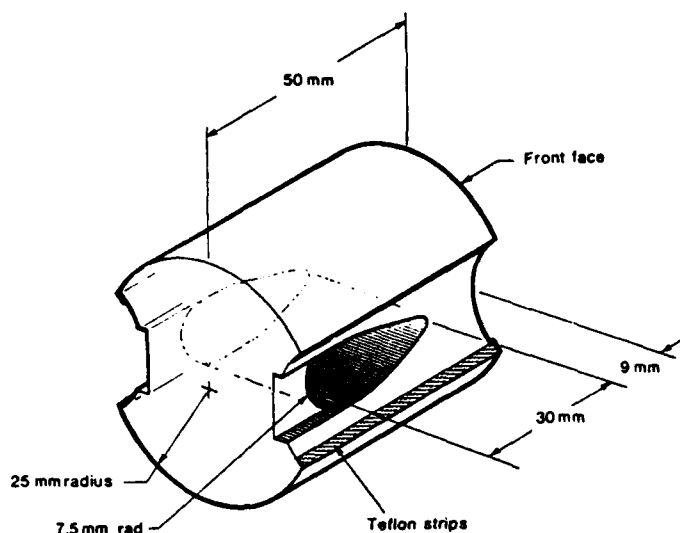

FIGURE 4 Polycarbonate Projectile

The scalloped sides key the projectile centrally between the rails such that it is self-supporting in that position (Fig. 5). Projectile clearance of $50\ \mu\text{m}$ was specified to provide a good sliding fit between the rails.

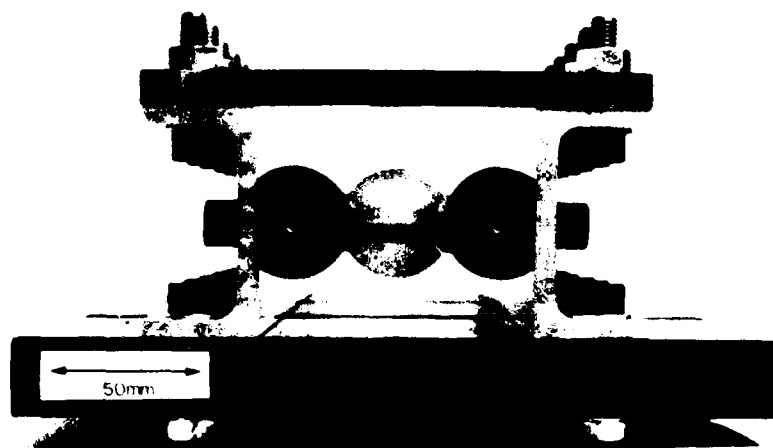

FIGURE 5 End view of launcher loaded with a projectile

The projectile cavity was wedge-shaped and machined through the projectile normal to its central axis. This design was chosen to provide greater wall strength in the frontal section of the cavity. It was expected that the frontal section would experience the maximum plasma pressure as predicted by Powell & Batteh [7]. They have shown that the plasma pressure rises to a maximum on the projectile face against which the plasma is pushed by the Lorentz force. Similar behaviour would be expected for the plasma confined within the cavity.

Three projectiles were used to test confinement of the plasma within the projectile. One had a close tolerance fit between the rails (50 μm clearance) (Fig. 6). The remaining two had 5 mm wide self-adhesive teflon strips (Tygaflor) along the edges of the scalloped sides (Fig. 4). The clearance between the projectile and the rails in this latter design was the thickness of the teflon strips (200 μm) plus 50 μm . The teflon bearing strips were used to reduce friction between the projectile and the rails. The mass of each projectile was approximately 80 grams.

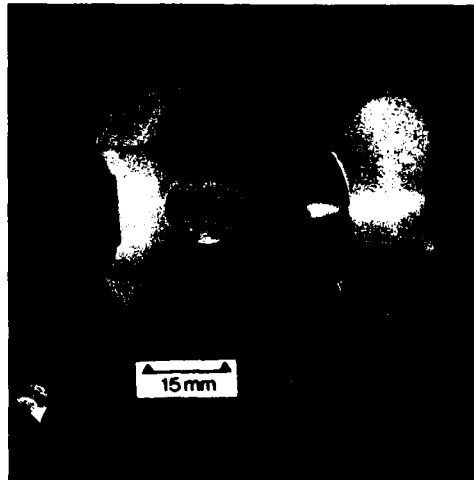

FIGURE 6 Photograph of a polycarbonate projectile

All projectiles had a groove 15 mm wide and 1.5 mm deep machined in each scalloped side. The groove extended from the rear end of the cavity to the rear face of the projectile so that the rear section of a moving projectile would not be obstructed by any arc damage produced on the rail surfaces caused by the plasma armature. These grooves would allow venting of the hot gases produced from the generation of the plasma and thus reduce the peak gas pressures within the cavity. The hot gases vented behind the projectile also provided a potential path for a shorting arc between the rails. The "open" design of CAPEL enabled any vented gases to expand into the atmosphere. Such expansion and associated cooling of the exhaust gases was expected to reduce ionisation and lower the conductivity of the gases. This reduction in conductivity would be expected to decrease the likelihood of arc initiation across the 30 mm rail gap. The curved face of the rails also minimised the chance of electrical breakdown between them.

3. EXPERIMENTAL RESULTS

The power supply consisted of a 1600 microfarad crowbarred capacitor bank connected to a 6.3 microhenry inductor (Fig. 7) which is described in reference 6.

Four low power firings were carried out to investigate the concept of plasma confinement. It was expected that there would be no acceleration

of the projectile in these firings as the Lorentz force was insufficient to overcome the static friction.

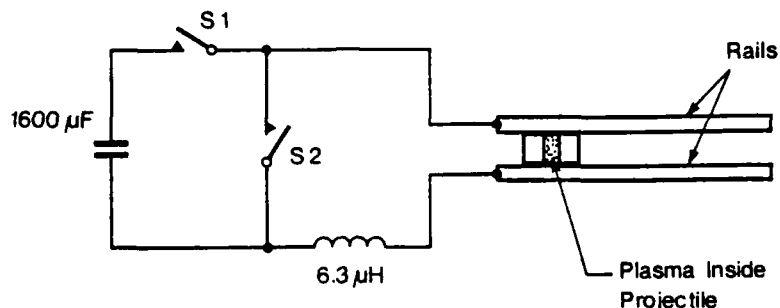

FIGURE 7 Circuit Diagram

The plasma within the projectile cavity was generated from the electrical explosion of 5 copper wires (0.05 mm diameter) upon the closure of switch S1 (Fig. 7). The wires were strung through the cavity via access holes in the rails shown earlier in figure 3.

3.1 Firing Number One

The first firing used a voltage of 6 kV on the capacitors (28.8 kJ) yielding a peak current of approximately 100 kA. It resulted in the destruction of the projectile. The projectile was cleaved in half between top and bottom (Figs. 8A & 8B). It was not possible to determine if the projectile had moved along the rails before it failed as the projectile segments were blown out of the rear of the launcher. This indicates that the front face split first and the reaction from the expanding plasma blew the two halves out of the launcher.

Arc damage to the rails was cleaned away by removing all the high spots so that the next projectile could slide over it easily. This was done after every firing.

3.2 Firing Number Two

To prevent destruction of the two remaining projectiles the voltage was reduced to 5 kV (20 kJ) for firings 2-4 inclusive. As shown in Figure 4, the projectile used in this firing had strips of teflon attached above and below the cavity to reduce sliding friction. The projectile survived the firing at the lower voltage with no observed displacement along the rails. There was no visible damage to the projectile although it had become stuck between the rails. The projectile was removed from CAPEL by manually pushing it along the rails out of the launcher. This required an estimated force of 50-100 Newtons. An examination revealed molten copper had been pushed between the projectile and rail interface where it had cooled and subsequently

jammed the projectile (Fig. 9). The teflon bearing strips, although discoloured with a black soot, were intact.

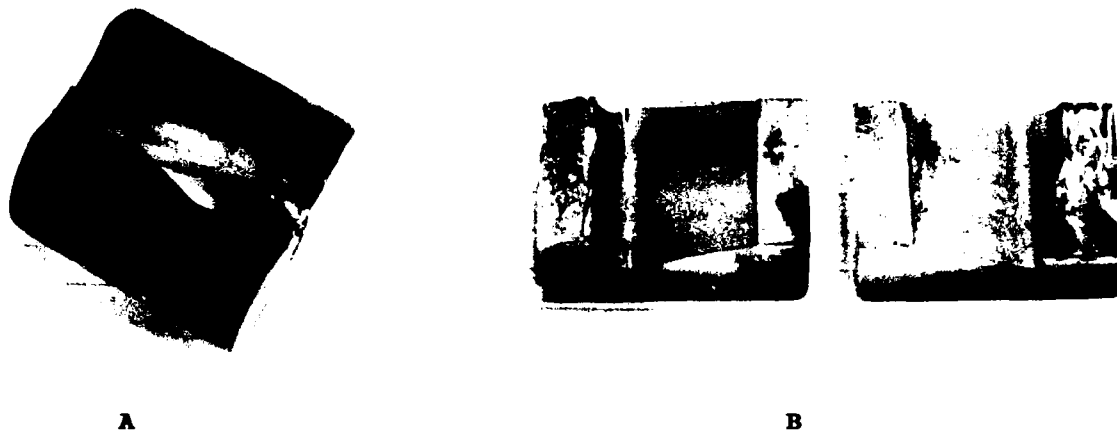

FIGURES 8A & 8B Photographs of split projectile

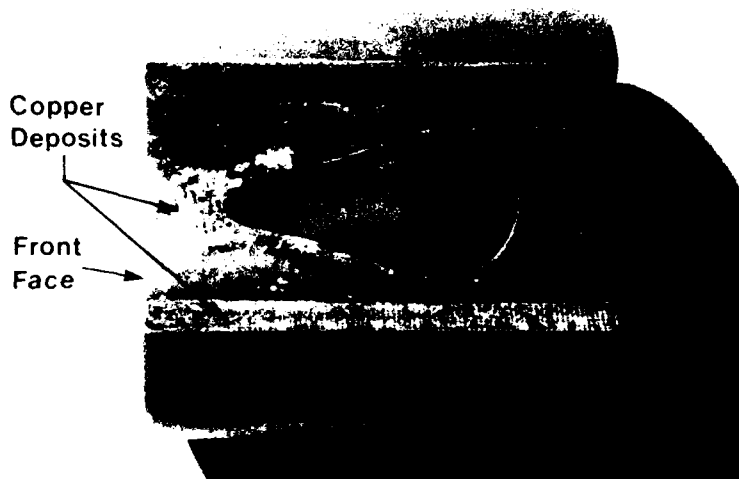

FIGURE 9 Jammed projectile with copper deposits on teflon bearing strips and side of projectile

Arc damage to the rails was severe, but it was confined to the rail area exposed to the cavity (Fig. 10). There was no evidence of any other arc damage around the projectile position.



FIGURE 10 Arc damage to the rails

Firing Number Three

Because firing No. 2 had molten copper forced between the projectile-rail interface, it was decided to further reduce the pressure within the projectile cavity. Consequently, the size of the rear grooves were enlarged in an attempt to increase the venting of electrically neutral gases and any ionised particles whose kinetic energy was high enough to escape from the magnetic confinement within the cavity.

A 12 mm wide slot with a 6 mm radius base, was machined to a depth of 7 mm and sloped inwards towards the cavity at 15 degrees on both sides on the projectile (Fig. 11).

The modified projectile survived the firing with no damage except for some "flame polishing" of the newly-machined surfaces. There was no visible damage to the teflon strips.



FIGURE 11 Modified projectile

The firing had moved the projectile 3 mm towards the muzzle end of the launcher. This small displacement of the projectile was caused by the Lorentz force and/or recoil from the vented gases. Calculations however showed that the Lorentz force was insufficient on its own to overcome the static friction. Hence it is believed that the 3 mm displacement was due to a combination of the Lorentz force and the recoil from the increased rear venting of hot gases created from the plasma generation.

Unlike the previous firing, the projectile had not become stuck between the rails and there were no copper deposits between the projectile-rail interfaces. To remove the projectile from CAPEL it was easily pushed forward (by hand) along the rails without obstruction from the arc damage on the rail surfaces.

A marked decrease in the degree of rail damage (Fig. 12) was observed. This could be due to a slight decrease in the current density as the enlarged grooves effectively increased the cross-sectional area at the rail-cavity interface. Further work would be required to validate this hypothesis. Consistent with the previous firings the areal extent of the arc damage on the rails matched the shape of the projectile cavity.



FIGURE 12 Decreased raised rail damage

3.4 Firing Number Four

This firing was a repeat of Firing No. 3. The projectile was moved 4 mm towards the muzzle and there was no observable damage to it. It slid forward easily and the arc damage area matched the cavity cross-section.

3.5 Firing Number Five

This firing aimed to accelerate the projectile from the launcher.

Computer simulation of the firing indicated that at least 100 kJ was required to attain significant projectile velocity. To achieve this, the storage capacitor was increased to 6000 microfarad and the firing voltage set at 6 kV (108 kJ). This was approximately five times the input energy level at which the projectile had survived intact in the earlier shots.

In order that the projectile might survive the expected higher plasma pressures, further modifications were made to it.

The cavity was enlarged considerably (Fig. 13) to a total length of 30 mm and a height of 16 mm. The front and rear internal walls of the cavity were machined to be concave with an 8 mm radius.

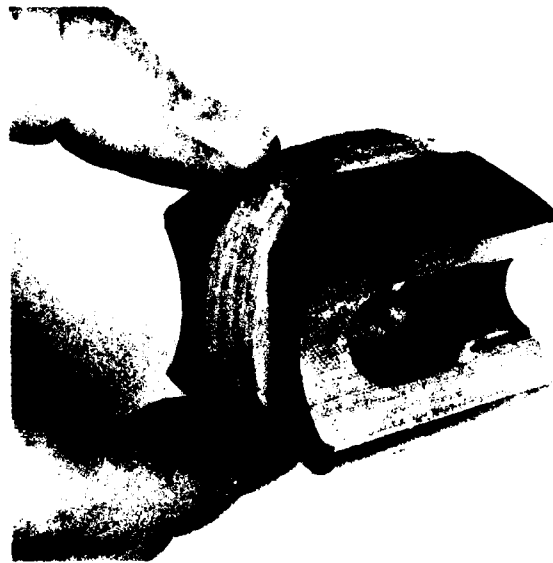

FIGURE 13 Modified projectile for Firing No. 5

This enlarging and changing of the shape of the cavity was done to further reduce the peak pressures from the plasma generation, reduce stress concentration at internal corners and to provide a larger frontal face on which the $J \times B$ induced force would be exerted.

To prevent the pressure against the top and bottom faces of the cavity from destroying the projectile, a 2 mm thick Kevlar 49 winding, 13 mm wide, was manually wound around the projectile using araldite epoxy as the adhesive. It was wound into a groove that had been machined lengthwise around the projectile (Fig. 13).

Calculations, which assumed that the Kevlar behaved as a thin wall of a pressure cylinder [8], indicated that it would contain the expected forces.

The two bearing strips of teflon on either side of the projectile were removed and replaced with identical material which covered the entire bearing faces (Fig. 13). This sealed a projectile-rail gap which had existed between the two bearing strips (Fig. 9).

To reduce the projectile mass and therefore increase the acceleration, the top and bottom corners were chamfered. The final mass of the projectile was 70 grams.

Due to the increased energy that this firing would require, it was expected that the rail damage would be greater than that experienced in firings 1-4. Therefore, to reduce the chance of the projectile becoming stuck it was decided to have the projectile moving before the power was applied. A simple pneumatic cylinder was constructed to give the projectile an initial velocity (Fig. 14).

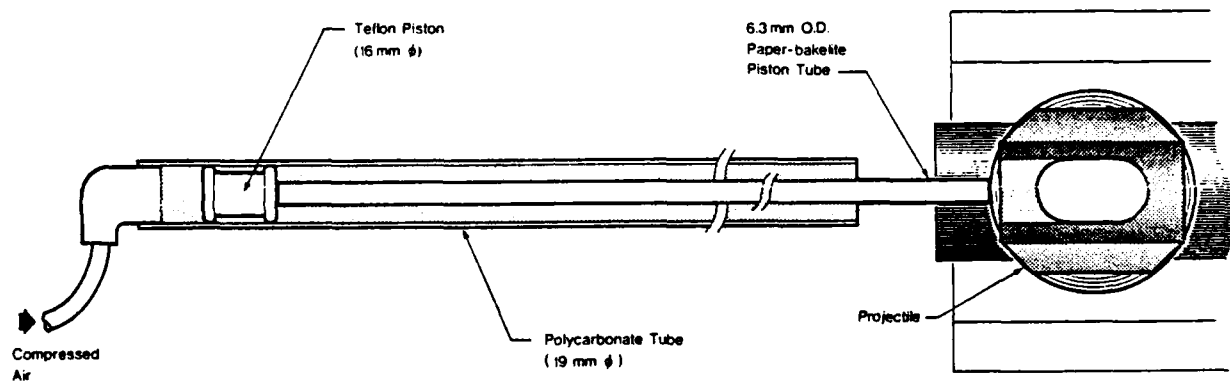

FIGURE 14 Pneumatic cylinder

Compressed air at a pressure of 700 kPa was switched into the cylinder by an electric relay. Tests revealed that the projectile would be accelerated to an average exit velocity of 19 m/s.

For the generation of the plasma, a strip of copper clad polyester (flexible printed circuit board material) was used instead of 5 copper wires. This technique overcame the difficulty of holding 5 wires within a moving projectile. The polyester strip, with a 50 μ m cladding of copper, was 45 mm long and 5 mm wide. It was held against the front wall of the cavity, copper side forward, with a thin strip of polystyrene foam (Fig. 15). This arrangement gave a good wiping contact between the rails.

For the firing, the projectile was positioned 70 mm from the breech with the piston rod held against its rear face. The projectile was pneumatically accelerated along the rails and when 150 mm from the muzzle the electrical power was switched on. The projectile was then electromagnetically accelerated out of the launcher. An exit velocity of 67 m/s was recorded. This represented a factor of 12.4 increase in the initial kinetic energy of the projectile.



FIGURE 15 Copper foil held in projectile cavity

Examination of the projectile after it was recovered from the "soft" catch tank revealed little external damage. The most obvious damage had been to the teflon bearing surfaces which were almost entirely removed (Fig. 16).

The cavity wall surfaces were covered with the familiar black soot which when removed, revealed flame polishing of the machined surfaces. Closer examination of the polycarbonate body revealed that it had failed mechanically. The front and rear walls of the cavity were completely penetrated by hairline cracks. The Kevlar winding, which appeared undamaged, had successfully held the two halves of the projectile body together during the firing.

The peak current of 130 kA produced severe arc damage to the rails (Fig. 17A & 17B). However, it appeared that the rail damage had not obstructed the projectile during acceleration. The arc damage was confined to a small distance along the rails. Calculations predicted that the projectile would only be accelerated over a distance of approximately 90 mm. This would explain the short region suffering rail damage.



FIGURE 16 Recovered projectile



← Muzzle

FIGURES 17A Anode damage



Muzzle →

17B Cathode damage

4. DISCUSSION

These results have successfully demonstrated, at low velocity, a new design concept in railgun technology. This design presents the following advantages over conventional railgun designs:

- (1) The design and construction is simple and therefore of low cost to construct.
- (2) Any rail damage can readily be repaired without complete disassembly, i.e. a relatively simple tool could be designed which would slide between the rails removing any high spots. It is worth noting that,

as with all railgun configurations, injection of the projectile at velocities equal to or greater than 700 m/s would significantly reduce arc damage [9].

- (3) The projectile is capable of carrying payloads mounted outside the rails (Fig. 18), e.g. RPV's, rockets. This is not possible with conventional railgun designs using a plasma armature.

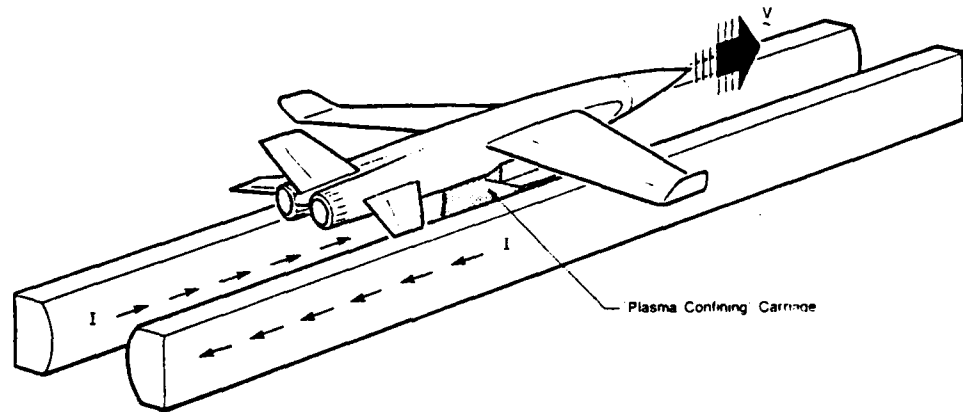

FIGURE 18 Conceptual RPV launcher

- (4) Electrical connection for distributed [10,11] or segmented [12] railgun configurations are straightforward as there are no confining barrel walls which need to be penetrated and sealed.
- (5) For high-repetition-rate firings the device could be easily air or liquid cooled.
- (6) The simplicity of the design may enable the maximisation of the inductance per unit length by appropriate rail design and/or magnetic field augmentation.
- (7) Multiple rail configurations are easily constructed with possible improvements in performance due to flux linking between sections (Fig. 19). Because the propelling force in this configuration can now be distributed, strength requirements of individual rails and supports can be reduced. Such distribution of force is not possible with a conventional railgun using a plasma armature. In theory there appears to be no limit to the size of projectile that can be launched.

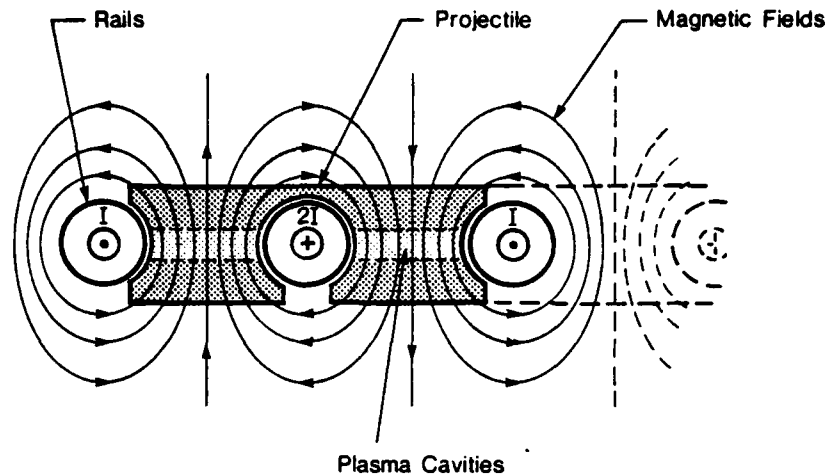
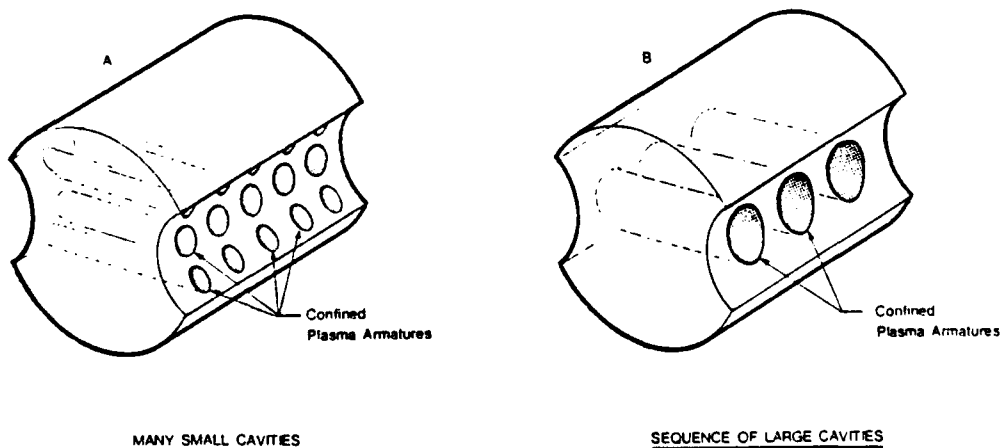

FIGURE 19 CAPEL with 3,4,5,N rails. Flux linking between sections may mean higher efficiencies

- (8) The need to clean the insulating walls of conventional railguns because of carbon and copper deposit buildup and impregnation is eliminated. A new "wall" (i.e. projectile) is used with each firing. In conventional railguns (using a plasma armature) the problem of wall contamination has yet to be solved.
- (9) Large projectiles could contain n plasma cavities (Fig. 20A, 20B). Each cavity would ideally have a current element I passing through it, where nI is the total armature current. This may enable the reduction of current densities to levels where arc damage is reduced if the current distribution can be maintained. Problems in achieving such a uniform current distribution have yet to be addressed. There was an observable decrease in the arc damage of firing number three when the cavity cross-section had been effectively increased. This possible control over the volume of the plasma may also alter its conductivity.



FIGURES 20A & 20B Possible control of current density due to distribution of plasma confining cavities

- (10) Because of the open structure, electrical and magnetic probing of the plasma armature throughout the entire firing is possible in experimental facilities for the first time. These probes can reside within the projectile or pass through the cavity walls to the plasma itself (Fig. 21).

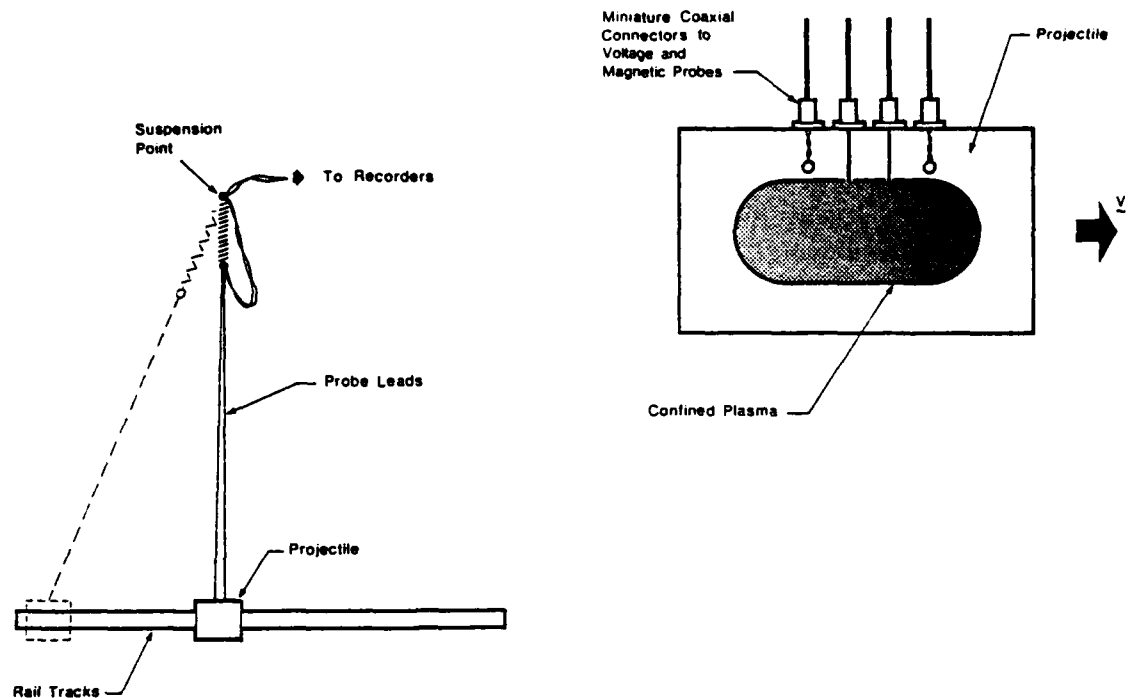

FIGURE 21 Instrumentation probes within the projectile

5. CONCLUSIONS

This preliminary research, conducted in the low velocity regime, leads to the following conclusions:-

- (1) A plasma armature can be successfully confined within an open-ended cavity of a CAPEL projectile.
- (2) The resultant $\underline{J} \times \underline{B}$ force upon the confined plasma is transferred to the projectile accelerating it along the rails.
- (3) Forces perpendicular to the $\underline{J} \times \underline{B}$ force produced the mechanical failure within the polycarbonate projectile. These forces were probably generated by the high pressure of the confined plasma and/or shock wave from the plasma armature creation. The application of a Kevlar winding around the projectile body provides a simple means to contain these dynamic forces within the projectile.

- (4) A polycarbonate projectile body will survive the high temperatures of the plasma armature with negligible thermal damage. This agrees with earlier results where polycarbonate barrels and projectiles have been used at MRL. This lack of thermal damage suggests there is a cool boundary layer between the plasma and the non conducting walls as predicted by theory [7].
- (5) The use of rear grooves to exhaust gases and to prevent obstruction to the projectile by arc damage on the rails was shown to be a successful technique.
- (6) Dynamic sealing at the top, bottom and front rail-projectile interface needs further design work. Leakage of small amounts of plasma may not prove to be a problem because the design of CAPEL reduces the chance of electrical breakdown.
- (7) Multiple-shot capability will only be achieved if rail damage can be kept low.

ACKNOWLEDGEMENTS

The author expresses his appreciation to Dr R. Marshall and Dr D. Richardson for their thoughts and suggestions regarding the design of the modified projectile. I also thank Dr A. Bedford for his support and D. Sadedin and D. Stainsby for their comments and suggestions in the drafting of this publication. Finally, but not least, I thank W.A. Jenkins, B. Jones and J. Ferrett for their technical assistance.

REFERENCES

1. Rashleigh, S.C. and Marshall, R.A. Electromagnetic Acceleration of Macroparticles to High Velocities. J. Appl. Phys. 49(4) April 1979.
2. Brooks, A.L., Hawke, R.S., Scudder, J.K. and Wozynski, C.D. Design and Fabrication of Large and Small Bore Railguns. IEEE Trans MAG-18 No. 1, Jan. 1982.
3. Bedford, A.J., Clark, G.A. and Thio, Y.C. Experimental Electromagnetic Launchers at MRL. MRL Report 894, August 1983.
4. Clark, G.A. and Bedford, A.J. Performance Results of a Small Bore Electromagnetic Launcher. MRL Report 917, Feb. 1984.
5. Stainsby, D.F. and Bedford, A.J. Some Diagnostic Interpretations from Railgun Plasma Profile Experiments. IEEE Trans on Magnetics Vol MAG 20, No. 2, 1984.
6. Kowalenko, V. Analysis of a Series of Electromagnetic Launcher Firings. MRL Report in preparation.
7. Powell, J.D. and Batten, J.H. Two-dimensional plasma model for the arc-driven railgun. J. Appl. Phys. 54 (5) May 1983.
8. Shigley, J.E. Mechanical Engineering Design. McGraw Hill Int. Book Co., ISBN 0-07-056881-2.
9. Unpublished results of MRL work on Ripper series of experiments involving injected projectiles.
10. Marshall, R.A. and Weldon, W.F. Analysis of Performance of Railgun Accelerators Powered by Distributed Energy Stores. Proceedings of the IEEE 1980 14th Pulse Power Modulator Symposium.
11. Holland, L.D. The DES Railgun Facility at CEM-UT. Proceedings of the 4th IEEE Pulse Power Conference, June 6-8, 1983, Albuquerque, NM.
12. Hawke, R.S. and Scudder, J.K. Magnetic Propulsion Railguns: their Design and Capabilities. LLNL Report UCRL-82677 (1979).

END

1-87

DTIC