

AD-A174 981

THE ARMY MOBILIZATION MANPOWER ACCESSION SYSTEM(U)
LOGISTICS MANAGEMENT INST BETHESDA MD
D S PICKETT ET AL AUG 86 LMI-FP601R1 MDA903-85-C-0139

1/1

UNCLASSIFIED

F/G 15/5

NL

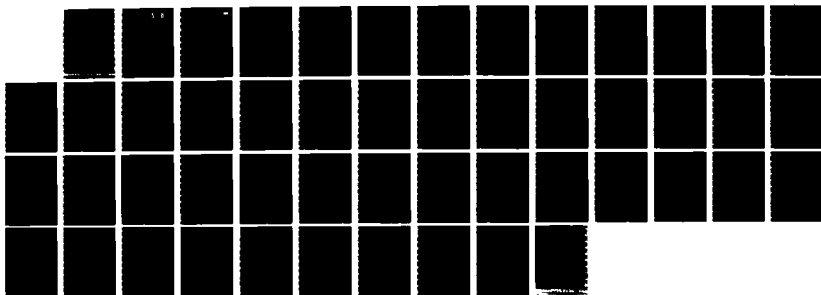

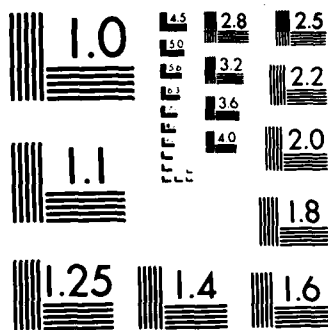

MICROCOPY RESOLUTION TEST CHART
NATIONAL BUREAU OF STANDARDS-1963-A

AD-A174 901

DTIC
SELECTE
DEC 10 1986
S D
D

12

THE ARMY MOBILIZATION
MANPOWER ACCESSION SYSTEM

Report FP601R1

August 1986

Dayton S. Pickett
John T. Durgala
David V. Glass

Prepared pursuant to Department of Defense Contract MDA903-85-C-0139.
The views expressed here are those of the Logistics Management Institute at
the time of issue but not necessarily those of the Department of Defense.
Permission to quote or reproduce any part must - except for Government
purposes - be obtained from the Logistics Management Institute.

LOGISTICS MANAGEMENT INSTITUTE
6400 Goldsboro Road
Bethesda, Maryland 20817-5886

DISTRIBUTION STATEMENT A
Approved for public release
Distribution Unlimited

86 12 05 00

FILE COPY



Executive Summary

THE ARMY MOBILIZATION MANPOWER ACCESSION SYSTEM

Since 1980, the Selective Service System has been prepared to fill the Army's stated requirement for 80,000 inductees to be provided during the first 30 days following mobilization. The Army, however, could train little more than half that many, because much of its training capacity would be needed for untrained or partially trained individuals from other sources, namely, the Delayed Entry Program, the Individual Ready Reserve, and Troop Program Units. The Army needs to revise its overstated requirement for inductees. We recommend that the Assistant Secretary of Defense (Force Management and Personnel):

Request that the Secretary of the Army adopt the following schedule of inductee requirements for the first 3 months following mobilization:

First month: 44,500,

Second month: 50,800, and

Third month: 61,800.

Advise the Director, Selective Service System, of the revised requirement.

We believe also that the Department of Defense needs a more comprehensive means of evaluating the Army's complex mobilization manpower accession system. In the event of mobilization, the Army's accessions would come from a variety of sources, enter in-processing at different stages, undergo training programs of different duration, and be collected at several centers for transport overseas. The methods now used to evaluate accession policy, training base capacity, and processing requirements do not deal adequately with the many possible combinations of source, training, and processing. As a result, bottlenecks and excesses in the system

go undiscovered and good alternatives go unexplored. We recommend that the Assistant Secretary of Defense (Force Management and Personnel):

Develop an integrated network model that characterizes the complex interactions among the various personnel sources, processing centers, and training institutions. A generalized model would be applicable to several of the Military Services, but should be tailored first to the Army. The Army should participate in developing the model to incorporate work it is now doing and to ensure that the model is capable of accommodating the various levels of detail needed by different agencies. We believe this model will be applicable to the other Services as well.

Finally, the Army should take steps to improve its mobilization manpower requirements systems, its plans for using personnel during mobilization, and its personnel inventory projection system. Specifically, we recommend that the Army:

Require that all mobilization requirements documents be updated twice a year.

Formulate plans to account for and utilize personnel in specialties excess to wartime needs.

Revise plans to allow untrained Troop Program Unit members to begin training without waiting for their units to mobilize.

Continue the ongoing effort to develop a single source of personnel inventory projections.



Accession For	
NTIS CRA&I	<input checked="" type="checkbox"/>
DTIC TAB	<input type="checkbox"/>
Unannounced	<input type="checkbox"/>
Justification	
By	
Distribution/	
Availability Codes	
Dist	Avail and/or Special
A-1	

TABLE OF CONTENTS

	<u>PAGE</u>
EXECUTIVE SUMMARY	ii
<u>CHAPTER</u>	
1. INTRODUCTION	1- 1
Task Overview.	1- 1
Overview of the Problem	1- 2
Organization of This Report.	1- 3
2. DEMANDS FOR TRAINED MANPOWER	2- 1
General	2- 1
Structure Requirements	2- 1
Casualty Replacement Requirements	2- 3
Transient, Holdee, and Student Requirements	2- 5
3. SUPPLY OF TRAINED MANPOWER	3- 1
Sources of Trained Manpower	3- 1
Training Base Output	3- 3
4. MOBILIZATION MANPOWER PLANNING	4- 1
General	4- 1
Training Requirements and Capacity	4- 1
Loading the Constrained Training Base	4- 5
The Current Plan	4- 8
Related Reports and Projects	4- 9
5. THE CURRENT PLAN: ANALYSIS AND CONCLUSIONS	5- 1
General	5- 1
Summary of the Availability of Untrained Manpower	5- 1
Inductees	5- 3
Advanced Individual Training	5- 4
Officer Training	5- 5
CONUS Replacement Centers.	5- 5

TABLE OF CONTENTS (CONTINUED)

<u>CHAPTER</u>		<u>PAGE</u>
6.	RECOMMENDATIONS	6- 1
	General	6- 1
	Inductee Delivery Schedule	6- 1
	A Conceptual Model	6- 1
	The Current System	6- 2
APPENDIX	A CONCEPTUAL MODEL	

1. INTRODUCTION

TASK OVERVIEW

This report addresses the Army's current system for accession of personnel during mobilization, with emphasis on the process for acquiring and training inductees during full mobilization.¹ In any major conflict, the pools of trained personnel readily available to the Military Services are not expected to meet the heightened demand for manpower. Inductees are one source of personnel that, when trained, can help support the nation's buildup.

The most recent set of planning figures for inductees was provided to the Selective Service System (SSS) in 1980. The Army, which requires the greatest manpower augmentation, is expected to receive the greatest number of inductees.

Since these plans were formulated, they have been subjected to considerable debate and review. The purpose of this report is to review the Army's manpower mobilization process and to identify potential improvements in the process. In addition to providing recommendations that will enable the Office of the Secretary of Defense (OSD) to give better support to Army mobilization manpower planning, we develop a concept for a model that will provide a methodology for estimating the capacity of the Army training base and the related inductee delivery schedule for the period from mobilization (M-day) to M + 90.

¹Full mobilization is a stage preparatory to total mobilization. Total mobilization is the complete harnessing of the nation's military and industrial might to conduct all-out war. For manpower planners, full mobilization is a convenient and reasonable planning target because of its well defined force size and configuration; total mobilization is less well defined from a manpower planning perspective. During full mobilization all units of the existing force structure must be brought to full wartime strength.

OVERVIEW OF THE PROBLEM

Figure 1-1 depicts the problem the Army will face during mobilization. In the early days of a conflict, the demand for trained manpower will exceed the supply. The demand will continue to increase from point A to D as additional force structure is mobilized and combat casualties occur. The steady growth in total manpower supply from points B to C is due to output from the training base, which had been loaded prior to mobilization. After point C, the supply of manpower increases rapidly as the mobilized Army training base produces increased numbers of newly trained personnel. Total manpower demand is first satisfied at point D when there has been sufficient opportunity to acquire and train additional personnel such as inductees. Mobilization planners are charged with developing programs to use the Army's personnel and training resources in the most effective manner possible so as to minimize the time required to meet total manpower demand.

A basic time-phased demand and supply analysis is the foundation of the Army mobilization manpower process. A set of automated systems are used to compare manpower demand and supply, in 10-day increments, for the first 180 days following mobilization. First, the total demand for manpower, consisting of force structure requirements, casualty estimates, and a personnel overhead account, is established. Next, the supply of pretrained individual manpower available to meet this demand is determined. Any projected shortages in manpower supply are programmed to be offset by inductees (and a much smaller number of volunteers) who must be trained before they can join the force. Results from this demand and supply analysis provide estimates for the number of inductees required and training goals for the Army training base.

In performing this mobilization manpower planning process, the Army must use estimates for such factors as combat casualties, available manpower, and training capabilities. These factors are not only highly sensitive to changes in policy and

FIGURE 1-1. MANPOWER DEMAND AND SUPPLY DURING MOBILIZATION

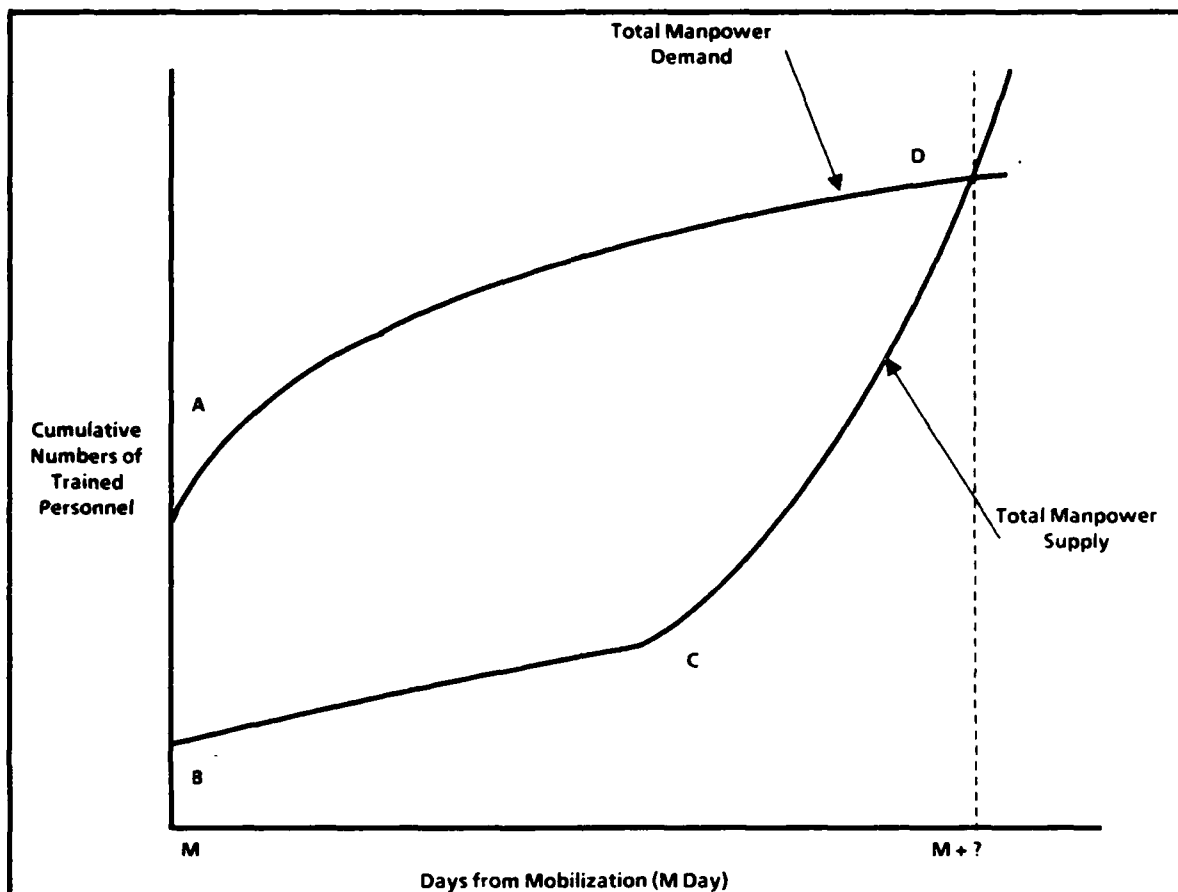

the cyclic fluctuations of the personnel inventory, but are also interrelated in complex ways. Because of the inherent variability of the key planning factors and the critical importance of mobilization issues, the planning function is the focus of continual interest and debate.

ORGANIZATION OF THIS REPORT

The organization of this report mirrors the usual steps followed in developing the plan for acquiring manpower during mobilization. After reviewing the manpower demand and supply factors in Chapters 2 and 3, we discuss the methods used by the Army for developing plans to meet the demand in Chapter 4. Projects that are now in progress and that affect mobilization manpower planning are also addressed.

In Chapter 5, we present our conclusions and our estimates concerning manpower demand and supply figures, the capacity of the training base, and the resulting effect on inductee planning. Recommendations are presented in Chapter 6.

Our discussion reflects the present Army practice of "worst case" planning. It assumes that full mobilization is ordered without warning and without an incremental buildup of forces.

2. DEMANDS FOR TRAINED MANPOWER

GENERAL

Total mobilization manpower demand is defined as the number of personnel needed during time of conflict. The components of total manpower demand are: force structure requirements; casualty replacement requirements; and transient, holdee, and student (THS) requirements. Each of these demand factors is described in this chapter.

STRUCTURE REQUIREMENTS

The first of the three demands for trained manpower comes from structure – the positions documented as being necessary in order to enable the Army to perform its wartime mission. The Mobilization Personnel Structure and Composition System (MOBPERSACS) is the single definitive statement of the Army's wartime need and, as such, provides a common basis for planning. Both Table of Organization and Equipment (TOE) units and Table of Distribution and Allowance (TDA) units are included in the MOBPERSACS. Active Army, Army National Guard, and U.S. Army Reserve (Composition One, Two, and Three, respectively) units are represented. Composition Four (COMPO 4) units – units for which a requirement exists but that do not now exist – are included if they can be supplied with equipment.

To incorporate force modernization changes and keep pace with recent decisions by Army leadership, the Army staff and major commands have implemented a regular review and updating process. Twice each year, during the January to March and July to September time periods, the basic authorization documents are updated. This process results in publication of the peacetime authorization document, the Personnel Structure and Composition System (PERSACS). Following the generation of the PERSACS, the MOBPERSACS is developed by focusing on the wartime

requirements. Schedules usually call for the MOBERSACS to be published in June and December of each year.

In the MOBERSACS, wartime requirements are probably more reliable for TOE units than for TDA organizations. In reviewing and documenting wartime requirements, as opposed to peacetime authorizations for TOE units, a different column in the authorization document is studied. This can be done simultaneously with the peacetime authorization review.

This is not true for Mobilization Table of Distribution and Allowances (MOBTDA). MOBTDA's are separate documents from peacetime TDAs and, by regulation, are updated annually or as needed. The accuracy of MOBTDA's, therefore, depends much more on the additional resources and effort that a command or installation can allocate to document maintenance. As priorities for maintaining MOBTDA's vary from command to command, so too can the resulting accuracy. At some installations the review of the MOBTDA is a regularly scheduled action. Each agency and activity that is affected provides input, and the General staff responsible for Force Development coordinates the final document submission. Other installations use a reservist to produce the MOBTDA with the entire action being accomplished during a 2-week active duty training period. Army representatives have also expressed concern with the MOBTDA positions that are designated as suitable for retiree assignment. These retiree positions may not be reviewed as often as is necessary to maintain an accurate account of the suitability of retirees to fill designated positions.

COMPO 4 units that are to be supplied with equipment represent the most questionable portion of MOBERSACS. The determination of which COMPO 4 units may be equipped is derived from the Mobilization Logistical Structure and Composition System (MOBLOGSACS). The MOBLOGSACS was last updated in 1984, raising serious questions as to its currency. Further, the focus of the COMPO 4

units that can be supplied with equipment is the last year of the Army's Program Objective Memorandum (POM). It is likely that the equipability characteristics for a future (1992, in this case) force are significantly different from those of earlier years.

Given the large quantities of data involved, there is reason to expect some degree of error and lack of currency in the structure demand that is derived from the MOBERSACS process. Internal review procedures, regular updates, and visibility by top leadership contain the error level within manageable tolerances.

It must be noted, however, that the structure demand is limited to filling the existing force structure. The demand does not include personnel requirements that would be needed if the force structure is expanded, as is likely for a war that extends beyond 180 days.

CASUALTY REPLACEMENT REQUIREMENTS

As soon as combat begins, casualty replacements will be required. Currently, Army personnel casualty data are developed as outputs of major continuing studies conducted by the Concepts Analysis Agency (CAA). The overall system is an adaptation of models already in use for equipment, ammunition, and support facilities. The system comprises at least six models and hundreds of thousands of data elements.

Combat casualties in the division, corps, and Communications Zone (COMMZ) areas are generated by computer simulation within the Force Evaluation Model at CAA. Noncombat losses in the division area and all losses in the corps and COMMZ areas are estimated by the application of historical loss rates to the various populations in those areas. These populations in the corps and COMMZ are generated by the Force Analysis Simulation of Theater Administration and Logistics Support Model. The net losses are then distributed over Military Occupation Specialty (MOS) and occupational categories by the Casualty Stratification Model.

At least three secondary models are needed to provide inputs. The arrival time of units in the theater is calculated by the strategic lift simulation called the Transportation Model. Detailed kill rates for various tactical conditions come from a division-level simulation called the Combat Sample Generator, which simulates 24 hours of combat between a "stylized" friendly division that is representative of the density of systems in the theater on the one hand and an appropriate enemy force on the other. The results of the Combat Sample Generator are input to the Force Evaluation Model. Results of medical treatment and disposition of wounded are derived from the Patient Flow Model.

Because of the complexity and size of the process and the year-to-year variations in projected casualties, the Army system of estimating casualties has come under close scrutiny. For example, "The Report of the Model Input Data and Processes Subcommittee of the Casualty Estimation Steering Committee," released by the Army in January 1986, expresses many concerns with the current processes, lists recommendations, and discusses improvements. Of immediate concern is an apparently high rate of casualties forecast for the peak period of combat. After study and analysis, these casualty rates were found to be consistent with those of both the Federal Republic of Germany and the United Kingdom for the peak period of combat. The Army's Deputy Chief of Staff for Personnel and Deputy Chief of Staff for Operations and Plans recently accepted the CAA rates as valid estimates for current and projected force analysis and directed continued study of nonpeak divisional casualty rates as well as corps and COMMZ rates.

The casualty estimation figures continue to be the center of debate and study. Considerable resources are being expended to improve both the understanding of the casualty process and the methodology used to describe the process. However, no matter how refined it becomes, this modeling effort, composed of dynamic conventional combat simulations and historical attrition factors, can provide planning

estimates only. Actual conflict casualties may be significantly different from the estimates. At this time, however, the CAA figures continue to be the best source of casualty data.

TRANSIENT, HOLDEE, AND STUDENT REQUIREMENTS

In both peace and war the Active Component of the Army must operate with a THS account. This type of personnel overhead is necessary to the process of acquiring, training, assigning, and reassigning individuals in order to meet the needs of the Army and facilitate personal development and promotion.¹ It represents a quantity of personnel that must be allowed for, above and beyond the quantity needed for normal duty positions. At present, personnel managers of the Army National Guard and U.S. Army Reserve have no THS or training, transient, holdee, and student (TTHS) account; instead, they carry this overhead as part of assigned unit strengths. Programs are underway to establish a Reserve Component account that is similar to the Active Component TTHS. Transients are individuals en route from one installation or duty assignment to another. Holdees are people who are being held either in hospitals or detention facilities. Students are both officers and enlisted personnel in some type of formal school other than Initial Entry Training (IET). The length of the schooling may vary from 13 weeks to 2 years or more.

To develop THS estimates for use in mobilization planning, peacetime historical data are modified to account for expected wartime changes. The active enlisted force THS is monitored through use of the U.S. Army Military Personnel Center Report called the DAPC 238. This report shows the numbers and percentages of enlisted soldiers by grade and MOS in each of the three THS categories over the past 12 months. The report is published monthly. Officer THS is followed in a similar

¹In peacetime, the active enlisted force includes training [Initial Entry Training (IET)] in the category and refers to the account as TTHS. The officer category is THS for both peace and war.

way by extraction of data from the Officer Master File. These historical THS data are forwarded from the Military Personnel Center to the responsible offices in the Office of the Deputy Chief of Staff for Personnel (ODCSPER). ODCSPER offices make adjustments in the peacetime THS to account for differences in the environment between peace and war. For example, the holdee account in wartime will be higher than in peacetime due to an increased patient population in Army hospitals. To obtain THS estimates, adjusted historical rates are then applied to projected mobilized force.

3. SUPPLY OF TRAINED MANPOWER

SOURCES OF TRAINED MANPOWER

General

To meet the demand for trained manpower upon mobilization, the Army can call upon personnel from several categories. Some of these personnel are already assigned to unit positions in the Active and Reserve Components, are already trained, and are deployable almost immediately. Others, such as members of the Individual Ready Reserve (IRR), are trained but will not be available for unit assignment until they undergo some initial processing. Six distinct groups provide initial sources of trained manpower.

Active Army

Members of the Active Army, both officer and enlisted, constitute the most readily available asset during mobilization. The Army maintains detailed records on assignments, skills, and qualifications that support mobilization planning. In addition, existing or developmental automated systems enable Army planners to project personnel inventories by grade and skill over the POM years. These systems help personnel managers control the active force and provide data for future mobilization planning. The primary system for projecting the enlisted force is the Enlisted FORECAST System. The officer counterpart system is not yet ready for use. In the interim, Army planners assume that the grade and skill distribution of the future year of interest will be the same as the distribution of the current officer inventory. These percent distributions are then applied to the aggregate Army authorized strength for officers for that future year.

Army National Guard and Army Reserve Troop Program Units

TPUs represent a second source of trained manpower. Members of TPUs are assigned to authorized unit positions and are monitored at different levels of aggregation by agencies on the Army Staff and by the National Guard Bureau and the Army Reserve Personnel Center (ARPERCEN). Though current inventories are readily available, there is no integrated system for providing projected strengths. As with the active officer force, current inventories are scaled forward in time for use in future projections.

Individual Mobilization Augmentees

Individual Mobilization Augmentees (IMAs) are members of the Selected Reserve who are assigned to the same unit positions in peacetime that they would hold at mobilization but do not train regularly with the unit. They typically join their unit for a 2-week training period each year. Most IMAs are members of TDA organizations, although emphasis is now being placed on assignments to Modified Table of Organization and Equipment units. Current IMA inventories are maintained by ARPERCEN.

Individual Ready Reserve

Members of the IRR have completed IET¹ (a large number have served on extended active duty), and are completing their Military Service Obligation (MSO) by assignment to the IRR. IRR members do not train on a regular basis, although a small percentage do elect to undergo annual refresher training at the invitation of ARPERCEN. During mobilization, IRR members will be ordered to a mobilization

¹A small number of IRR members have completed only a portion of their IET. They are discussed in detail in Chapter 4.

station, to a deploying unit, or to an Army unit that is already in theater.² ARPERCEN maintains figures on the current IRR inventory.

Retirees

There are several categories of Army retirees based on age and recency of active Service. For planning purposes, the Army considers as trained assets only those retirees who hold preassignment orders assigning them to installations upon mobilization. As a general rule, retirees are not assigned overseas (unless they reside overseas or volunteer) and can be assigned only to a position that is officially designated as suitable for retiree assignment. ARPERCEN maintains the retiree data and administers the preassignment orders program.

Veteran Volunteers

A source of trained manpower that is receiving increased attention is that of veteran volunteers. This category consists of individuals who have previously served in the Army and have fulfilled their MSO. It is reasonable to expect that some of these veterans may, in time of conflict, offer to reenter the Army. Veteran volunteers constitute a trained asset pool that, after administrative processing, could be available in a relatively short time. The Army has begun work on a mechanism to manage veterans who do volunteer upon mobilization. Quantitative planning figures are not yet available.

TRAINING BASE OUTPUT

A final source of trained manpower, different from the six groups discussed above, is the continuing output from the Army training base. The Army training base consists of all U.S. Army Training Centers, Service (and other) schools, and

²At present, assignments to forward deployed units or to casualty replacement pools in theater are limited to those IRR soldiers who are fully trained and who have been released from active duty within the first year.

academies and specialized training institutions. The Army training base exists to supply trained individuals to the force.

IET for enlisted soldiers consists of an 8-week (7-week during mobilization) Basic Combat Training (BCT) course followed by more specific occupational training called Advanced Individual Training (AIT). AIT course lengths vary greatly and cover the spectrum of Army MOSs. One Station Unit Training (OSUT) is conducted in lieu of BCT/AIT for most combat and some combat support skills.³

Most Army officers are trained and commissioned through either the United States Military Academy or the Reserve Officer Training Corps (ROTC) program, which is conducted at civilian colleges and universities. After commissioning, officers attend an Officer Basic Course (OBC) to receive branch-specific training. A smaller number of officers enter the force through the Officer Candidate School (OCS) system. These officers are commissioned after an intensive, 12-week course. They then complete the OBC curriculum.

Several other courses and schools support career progression and professional development within the Army. Among such courses are the basic Non-commissioned Officer Course, the Sergeant Major's Academy, Officers Advanced Course, the Command and Staff College Course, and the U.S. Army War College. Specialized courses for ranger, airborne, language, and other skills are also offered.

The decision to mobilize will cause sweeping changes within the Army training base as it converts from peacetime to wartime operations. For enlisted training, U.S. Army Reserve training divisions/separate brigades, the U.S. Army Reserve Schools, and U.S. Army Reserve Reception Stations (RECSTA) will augment or expand the peacetime facilities to bring the mobilization base from 8 to 14 training centers and RECSTA. The training pace will be accelerated and the number of

³The successful completion of BCT/AIT leads to the award of a MOS, as does the successful completion of OSUT. BCT/AIT and OSUT are both called IET.

training days per week extended to increase training base output. The U.S. Military Entrance Processing Command will be augmented and will deliver an increased number of new trainees to the training base every day. In addition, the Army's Health Services Command will increase dramatically the training activities of its Academy of Health Sciences in support of the increased medical manpower demands of war.

Officer training during mobilization will place greater emphasis on providing essential specialty training for new officers. The OBC will accelerate to a 6-day week and 10-hour day. Branch Immaterial Officer Candidate School (BIOCS) is to be established at four separate locations and is to be followed by branch-specific training. Infantry, Armor, Field Artillery, and Engineer Branches are scheduled to conduct Branch Specific Officer Candidate Schools (BOCS). Intermediate- and staff-level training such as the Officer Advanced Course and Command and Staff Course will be terminated or drastically compressed. Senior-level staff training will continue with a mobilization Program of Instruction.

4. MOBILIZATION MANPOWER PLANNING

GENERAL

Because of the time required to produce newly trained individuals (113 days or longer), early demand for military manpower can be filled only from assets already under military control. The Army expects to experience serious manpower shortfalls in critical combat and medical specialties. This shortfall will peak during the first 30 days of hostilities, when early battle losses are likely to be high, returns to duty of previously evacuated personnel are low, and output from the mobilized training base has not yet increased significantly. Recognition of this likelihood requires that Army mobilization manpower planning activities focus on minimizing the extent of the shortfall. We now describe these activities in detail.

TRAINING REQUIREMENTS AND CAPACITY

The 1322 System

The 1322 System is a process for matching the Army's full mobilization manpower demand against trained manpower assets. Mobilization manpower demand consists of structure requirements from the MOBPERSONS, casualty loss data from the CAA's Casualty Stratification Model, and THS figures as projected for the year of interest.

Trained manpower assets include the Active Army, Army Guard, and U.S. Army Reserve TPU strengths, IMA, IRR, retirees, and training base output of personnel in training on M-day.

For consistency, all data are referenced to the same end of fiscal year date. For example, the current 1322 report will be based on structure, casualty, THS, and personnel asset figures as of 30 September 1987. The 1322 System data are provided

in 10-day increments from M-day to M + 180. Shortages and overages at the MOS and skill level of detail are provided.

The shortfall results become the Mobilization Training Base Output Requirement (MTBOR) for use by planners in the training community and thus are key factors for programming inputs into the training base. At this time there is no plan to manage soldiers with specialties excess to the needs of the mobilized Army, even though these individuals are available in significant numbers and would be used in some capacity in time of war.

The Mobilization Army Program for Individual Training

After the MTBOR has defined the Army's needs in terms of trained manpower, the training base must be programmed (or loaded) to meet the need. The Mobilization Army Program for Individual Training (MOBARPRINT) is the plan for accomplishing this training mission. Following a reverse planning process, the MOBARPRINT schedules trainees through BCT/AIT, OSUT, OBC, and OCS in accordance with the structure limitations of the training base units and associated cadre. The MOBARPRINT provides an orderly method for notifying training installations of planned mobilization inputs. It is also a means of aggregating output data to verify accomplishment of the training mission. Figure 4-1 shows the relationship of the 1322 System, MTBOR, and MOBARPRINT.

FIGURE 4-1. DEVELOPMENT OF THE MOBARPRINT

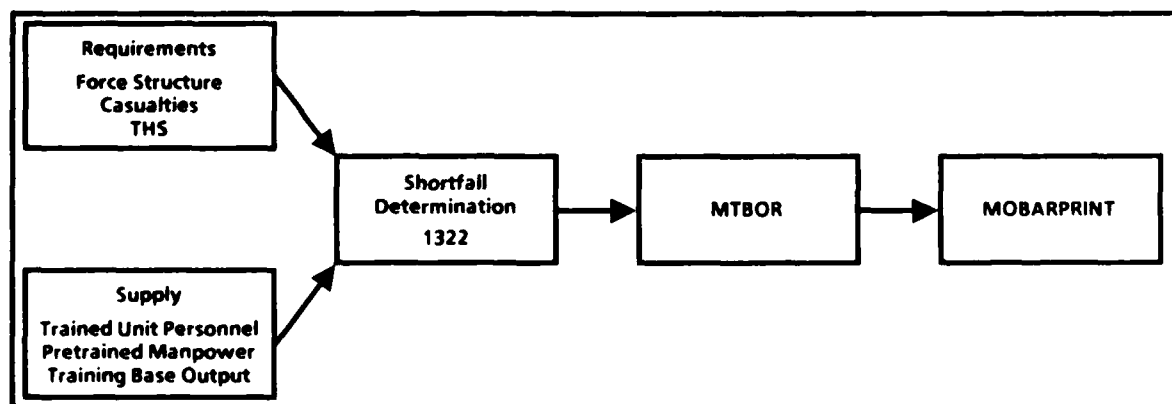

Training Base Constraints

Once the programmed inputs for the training base have been provided in the MOBARPRINT, the capacity of the training base to meet this output must be considered. Three studies, each incorporating increasing levels of detail, have been conducted to evaluate that capacity. The most recent of these studies, Training Base Capacity Study 85 (TBCS 85), was conducted from March through September 1985 to document capabilities to expand the training base upon full mobilization. The TBCS 85 was essentially a manual analysis involving detailed coordination between program of instruction proponents, all installation activities supporting the training base, and U.S. Army Reserve training units that augment or establish a U.S. Army Training Center. Participants in the study were provided standard assumptions and asked to maximize their trainee input capacity given local resource constraints to determine their mobilization capabilities. BCT, OSUT, AIT, OBC, BIOCS, and BOCS capabilities were reported. The results of the TBCS 85 are considered to be the most accurate time-phased data to date on training base capacity during mobilization.¹

Capacity Versus Programmed Requirement

The input capacities and requirements for each of the courses reported in the TBCS 85 are displayed in 30-day increments from M to M + 180 in Table 4-2. Certain features of the capacity figures merit further discussion. It would be logical to expect the capacities to increase slowly and then level off, reflecting the increased capability gained with the mobilization of the Army Reserve training organizations. Instead, large fluctuations are noted. These fluctuations are caused by the

¹In October 1984, the United States General Accounting Office (GAO), in a report entitled, Better Use of Available Data Would Improve Mobilization Planning for Inductees, estimated the IET training-base capacity for the first 30 days following mobilization to be 56,000. We have reviewed the GAO report and feel that the capacity figures provided in the TBCS 85 are better estimates since they more accurately reflect the present situation.

accumulating limitations of facilities and training equipment as scheduled courses begin to overlap in the days following mobilization. There are also some artificial limitations experienced in the imprecise conversion of training week inputs to 30-day capacities.

TABLE 4-2. TRAINING INPUT CAPACITY AND REQUIREMENT BY COURSE
(In Thousands)

COURSE	M + 30		M + 60		M + 90		M + 120		M + 150		M + 180	
	Cap	Req	Cap	Req	Cap	Req	Cap	Req	Cap	Req	Cap	Req
BCT												
Incremental	50.3	56.4	42.9	58.9	50.5	57.2	56.7	60.7	41.7	44.9	39.4	44.9
Cumulative	50.3	56.4	93.2	115.2	143.7	172.4	200.4	233.1	242.1	278.0	281.5	322.9
OSUT												
Incremental	27.2	33.8	29.1	45.3	28.9	43.6	42.6	64.1	36.8	51.8	36.8	51.6
Cumulative	27.2	33.8	56.3	79.1	85.2	122.7	127.8	186.9	164.6	238.7	201.4	290.3
AIT												
Incremental	11.1	11.1	14.1	18.6	19.2	32.1	31.2	46.6	25.7	36.9	24.5	40.8
Cumulative	11.1	11.1	25.3	29.7	44.5	61.7	75.7	108.3	101.4	145.2	125.9	186.0
OBC												
Incremental	4.2	4.3	3.3	4.4	4.0	5.4	4.4	5.0	2.2	2.0	1.8	1.8
Cumulative	4.2	4.3	7.4	8.7	11.4	14.0	15.8	19.0	18.0	21.0	19.9	22.8
BOCS												
Incremental	2.0	2.2	5.2	5.2	5.1	5.3	5.0	6.3	4.2	5.1	4.2	4.8
Cumulative	2.0	2.2	7.2	7.4	12.3	12.7	17.3	18.9	21.5	24.0	25.7	28.8
BIOCS												
Incremental	2.0	10.0	10.0	40.0	20.0	40.0	30.0	50.0	24.0	40.0	24.0	40.0
Cumulative	2.0	10.0	12.0	50.0	32.0	90.0	62.0	140.0	86.0	180.0	110.0	220.0

SOURCE: Data from the Training Base Capacity Study, 1985.

NOTE: Cap = Capacity, Req = Requirement.

AIT capacity presents special concerns. Based on the TBCS 85 figures, it appears that AIT input capacity is insufficient to accommodate the output from BCT. Army training managers have acknowledged this potential problem and are addressing it. In the interim, the U.S. Army Training and Doctrine Command (TRADOC) is programming AIT for inputs in excess of the quantities that the installations and units report they can support. The resolution of the issue is complicated by the accounting measures used in the TBCS 85. AIT courses for some specialties do not have capacity to train the total numbers that the Army needs. Other AIT

courses have capacity in excess of Army demands. In the TBCS 85, courses with excess capacity were capped at the levels reflecting the training requirement.

LOADING THE CONSTRAINED TRAINING BASE

General

With the training requirements and capacities determined, the schedule for delivering trainees to the training base can be produced. Several pools of untrained (or partially trained) individuals are available to the Army without resort to conscription: participants in the Delayed Entry Program (DEP), the untrained (called zero-skilled by planners) members of the IRR, those individuals who are members of TPUs and are awaiting initial active duty for training (AIADT) or have elected the split training option (STO), and volunteers. Each of these pools will be discussed individually below.

Delayed Entry Program

Over 99 percent of the individuals entering the Army during peacetime are members of the DEP for some period of time. The only exceptions are those who enlist at a Military Entrance Processing Station (MEPS) and are immediately assigned to a seat in the training base and sent to a RECSTA. For the vast majority there is a delay between enlisting and beginning training.

The DEP gives the Army the flexibility needed to match peacetime volunteers with appropriate training at a time when it is useful to the Army so that the individual will have a spot available in a unit after training is finished. This flexibility gives the Army more control over its manpower and training resources and allows both to be used more efficiently.

Individuals can remain in the DEP for up to a year. Prior to being placed in the DEP, these individuals are given mental and physical testing to assure their suitability for active Service and training. As members of the DEP they belong to a

U.S. Army Reserve Control Group, thus giving the Army the legal right to call them to active duty during mobilization or other national emergency.

The average population of the DEP over the past 12 months is approximately 45,000. Of these, about 16,500 are eligible to be called to active duty at any one time (those under age 18 and those still in high school and under age 21 are not eligible). Of those eligible, about 14,000 are males and 2,500 are females. These averages have large seasonal fluctuations, with the eligible population ranging from a high of over 25,000 in October 1985 to a low of 10,300 in April 1985.

Upon being called to active duty during mobilization, a member of the DEP will report to a MEPS where they will be given a quick medical examination and be sworn into active duty (having already taken the Armed Forces Vocational Aptitude Battery, additional mental testing, and a physical on entering the DEP). The stay at the MEPS should be brief – no more than a few hours. They will then go to a RECSTA and enter training.

It is assumed by the Army that virtually all members of the DEP called for active duty during mobilization will report as ordered.

Zero-Skilled Individual Ready Reserve

The zero-skilled IRR is made up of individuals who, because of exceptional personal considerations, had to leave the Army prior to completion of their IET, but after the completion of BCT or the first half of OSUT. They have been screened by their training battalion commanders and deemed to be potentially useful mobilization assets for the Army. Approximately 10 percent to 20 percent of those leaving training are retained in the zero-skilled IRR. Upon leaving active duty these individuals stay in the IRR for the remainder of their MSO (now 8 years in total).

There are about 15,000 individuals in the zero-skilled IRR. It is anticipated that 50 percent to 70 percent of those called to active duty will report as ordered.

When called for active duty, members of this group will report to the MEPS where they will be given all the standard entrance examinations. Since they have already been on active duty, any failure of the mental tests will be considered deliberate and will not disqualify them from active duty. Although all members of this pool have completed BCT, or the first half of OSUT, present policy calls for them to repeat BCT or to begin OSUT again.

Untrained Troop Program Unit Members

Both the Guard and Reserve include members of TPUs who are not fully trained. Some are AIADT and have had no training at all. Others have completed BCT (or the first half of OSUT) and are awaiting active duty to begin their AIT (or the second half of OSUT); they are participants in the Army's STO. Finally, there are a number of TPU members undergoing training in the training base.

The average population of those members of TPUs who have had no training is about 21,000, of those awaiting the second half of the STO about 21,000, and of those in training about 23,000.

Mobilized members awaiting initial training or the second half of their split training will report with their units to the mobilization station. At that point they will be identified to the installation commander as requiring training. They will be separated from their units and, with their personnel files, report to a processing official who will assign them a seat in the training base, using the current Army reservation system. This assignment will be done by individuals from the United States Army Recruiting Command (USAREC), which plans to reassign some portion of its personnel to the mobilization stations for this purpose.

Once assigned a seat in the training base, the individual must be transported to the appropriate training station and will thus enter the training base at least 3 or 4 days after his unit reports to the mobilization station.

About 95 percent of those called up with their units are expected to report to the mobilization station. Since all of these soldiers have already been qualified for Military Service and have enlisted, their records should disclose any training limitations that exist.

Volunteers

The last group of untrained individuals available to the Army without conscription consists of volunteers. Planners now expect approximately 2,000 acceptable volunteers a week after mobilization. This rate is lower than the Army's peacetime rate, which amounts to almost 10,000 a month.

The actual number of mobilization volunteers would depend on a number of variables, chief among them being the level of popular support for the conflict that precipitates mobilization. This factor would also influence the time-phasing of volunteers. There might be a great many in the first months and fewer in later months. Significant seasonal variation is also possible. An examination of historical data may shed some light on the subject.

Inductees

Once all the above sources of trained and untrained manpower have been exhausted, inductees will be called to help satisfy the remaining manpower demand. The Selected Service System (SSS) is prepared, upon authorization by law and direction by the Department of Defense (DoD), to notify preregistered individuals to report for induction processing. It will take 13 days for the first inductees to receive notification, travel, and process through the MEPS.

THE CURRENT PLAN

Delivering Untrained Manpower to the Training Base

The Army plans to receive eligible members of the DEP at training centers during days 2 through 13 after mobilization. They would be followed by the zero-skilled IRR in days 14 and 15 if there is no conscription. If there is conscription,

inductees will report to the MEPS beginning day 13 and the untrained IRR will report on days 31 and 32. The untrained TPU members will report for training as scheduled by the USAREC official at the mobilization station of the TPU. Volunteers are expected to arrive at training centers beginning on about day 16.

Delivering Trained Manpower to Battle

In June 1984, the CONUS Replacement Center (CRC) Implementation Plan was approved. The CRC mission is to process trained individuals and some unit packages for battle. Specifically, the CRCs are to provide billeting and messing for processing personnel, verify overseas replacement orders, issue equipment and weapons, validate movement instructions, and coordinate movement of personnel to Aerial Ports of Embarkation.

During the first 13 weeks following mobilization (Phase I) the flow of personnel to the CRCs will be relatively small and will originate from many different locations. The individuals to be processed will consist of individuals returning from the THS account, the initial output of the training base, and some IRR members assigned to forward deployed units. In Phase II (week 14 and beyond) the flow of personnel to the CRC will be larger and more concentrated. Medical-return-to-duty personnel and graduates of Army schools not colocated with Army Training Centers will constitute the greatest portion of individuals to be processed. After week 13 of mobilization, trainees at Army Training Centers will move directly from the centers to Aerial Ports of Embarkation. At present, CRCs are planned for Fort Jackson, South Carolina; Fort Dix, New Jersey; and Fort Lewis, Washington.

RELATED REPORTS AND PROJECTS

The Wartime Manpower Planning System

The Wartime Manpower Planning System (WARMAPS) was established in 1980 as the standard DoD-wide procedure for reporting the personnel requirements and personnel availability for a conflict. It is prepared annually and, based

upon deployment and warfighting scenario from the Defense Guidance, reports personnel requirements and strengths for the first and last year of the POM.

The Army has developed an independent WARMAPS feeder system to support or feed Office of the Secretary of Defense (OSD) WARMAPS. This feeder system is similar to the 1322 system. The major difference is that neither the Army feeder nor OSD WARMAPS provides MOS and skill level detail. Shortages and overages are shown for officer, warrant officer, and enlisted personnel by six major categories: close combat, other combat, combat support, maintenance, medical, and other. With this level of aggregation there is a tendency to mask shortages and compromise the utility of the report for detailed manpower planning. For example, in the most recent Army WARMAPS, a total overage of 59,300 individuals is reported for fiscal year 1988 (FY88) at M+90 even though the combat and medical categories are expected to have shortages of 49,000 and 40,800, respectively.

The Mobilization Manpower Planning System

The Army WARMAPS feeder system and the 1322 System are both used in mobilization planning. These two systems perform in a satisfactory manner, but produce conflicting output, are cumbersome to modify, and have slightly different methods of determining requirements. To overcome these deficiencies and provide additional capabilities, the Army has funded the Mobilization Manpower Planning System (MOBMAN) contract.

The MOBMAN is intended to become the Army's authoritative system for mobilization manpower planning. In concept design, the MOBMAN will be capable of dealing with all levels of mobilization (except total), address the effect of equipment on manpower, operate in an interactive mode, and fully support current WARMAPS and 1322 System requirements. The first portion of the MOBMAN is scheduled to be delivered to the Army in the summer of 1986.

The Mobilization Training Capacity Requirements Determination System

Recognizing the importance of being able to estimate and manage the output of the training base during mobilization, OSD has funded the Mobilization Training Capacity Requirements Determination System (MOBTRAC) project. The MOBTRAC is a prototype computerized simulation model designed to help measure the Military Departments' capability to produce trained manpower with the military skills needed to support various levels of mobilization. Basically, the MOBTRAC is an automated tool that will support such efforts as the TBCS 85. When complete, it will convert existing training assets into estimates of trained manpower that can be produced, indicate skill-specific shortfalls and surpluses in trained manpower outputs, and provide a cost-benefit analysis for reallocation and acquisition of training assets.

The planning and analysis capabilities offered by the MOBTRAC are needed by Army training managers. Similar efforts, some of which may be accomplishing some of the MOBTRAC objectives, are already underway within TRADOC, however. Further, the present MOBTRAC design requires vast amounts of data input from existing but diverse Army data sources.

5. THE CURRENT PLAN: ANALYSIS AND CONCLUSIONS

GENERAL

In this chapter we assess the present plan for training the pools of untrained individuals who will be needed during mobilization. Our focus is the availability of personnel and the capacity of the training base to accommodate these new trainees. Although IET for enlisted soldiers commands the greatest part of our attention, we also comment on officer training and the movement of newly trained personnel to the conflict.

SUMMARY OF THE AVAILABILITY OF UNTRAINED MANPOWER

The average annual population of the various manpower pools and their annual maximums and minimums are displayed in Table 5-1. Our estimates of the untrained or partially trained manpower available to the Army from these pools during the first few months of mobilization are listed in Table 5-2.

TABLE 5-1. POPULATION OF MANPOWER POOLS

POPULATION	AVERAGE	HIGH	LOW
DEP (total)	45,200	60,500	31,300
DEP (eligible)	16,500	25,500	10,300
Zero-skilled IRR	15,000	15,100	13,000
TPUs			
AIADT	21,400	26,000	18,200
STO	21,000	27,700	15,900
In training	23,100	31,900	16,800

SOURCE: FY85 data from Army Reserve Personnel Center (ARPERCEN), Accessions Division Office of the Deputy Chief of Staff for Personnel (ODCSPER), and the Defense Management Data Center.

TABLE 5-2. ESTIMATES OF AVAILABLE MANPOWER

CATEGORY	MONTH 1	MONTH 2	MONTH 3
DEP	16,500	9,600	9,600
Zero-skilled IRR	9,000		
TPU (AIADT)	15,500	5,500	
Volunteers	8,000	8,000	8,000
TPU (STO)	(15,500)	(5,500)	
TOTAL UNTRAINED	49,000	23,100	17,600

The first entry of Table 5-2 shows the average number of DEP eligibles, 16,500, being called in the first month. During the next 2 months the remaining members of the DEP are called as they become eligible (which they do at the average rate of 9,600 a month). Present Army plans consider only those eligible in the first month. They do not include explicit provisions for calling those remaining members of the DEP who become eligible in ensuing months.

During the first month, an estimated 9,000 members of the zero-skilled IRR report to the MEPS. This is midway between the 50 percent to 70 percent now used as "show rate" estimates. A better estimate may be available after the results of the FY87 IRR muster become available.

Of the 21,400 members of TPUs AIADT, 15,500 or about 73 percent will report with their units and enter the training base in the first month; the remaining 5,500 will report in the second month. This estimate is based on our best judgment of the reporting schedule for mobilizing units and the distribution of untrained personnel assigned to these units.

The table lists the Army estimate of 2,000 acceptable volunteers a week, or about 8,000 a month. This figure is lower than the peacetime level of 3,000 volunteers a week. Since we can suggest no other defensible estimate for volunteers, we use the Army figure.

The fifth line of the table distributes the 21,000 members of TPUs in the STO who will be entering AIT (or the second half of OSUT): 15,500 in the first month and 5,500 in the second. These estimates are based on notional reporting dates to mobilization stations.

The last line totals the untrained who will enter either BCT or the beginning of OSUT (i.e., it does not include line 5, the STO members). Thus we estimate that 49,000 people will be available to be called by the Army in the first month of mobilization without resorting to conscription, 23,100 will be available in the next month, and 17,600 in the third month.

INDUCTEES

Present plans call for SSS to deliver as many as 80,000 inductees for Army use by M+30 and 265,000 by M+90. Table 5-3 shows our estimates for inductee training capacity. These estimates indicate that the training input capacity for BCT and OSUT is considerably less than this maximum number of inductees. Under our assumed plan for scheduling untrained manpower into the training base, about 28,500 inductees can begin training by M+30, while about 16,000 inductees will be waiting in the RECSTA to begin training early in the next month. This means approximately 44,500 inductees can be accommodated by the Army by M+30. Corresponding inductee figures for the 30-day increments ending at M+60 and M+90 are 50,800 and 61,800, respectively, for a cumulative total of 157,100 inductees by M+90.

TABLE 5-3. ESTIMATED INDUCTEE TRAINING CAPACITY

CATEGORY	MONTH 1	MONTH 2	MONTH 3
Input Capacity of BCT and OSUT (from Table 4-2)	77,500	72,000	79,400
Total Untrained (from Table 5-2)	49,000	23,100	17,600
Remaining Inductee Training Capacity	28,500	48,900	61,800
Inductees in RECSTA	16,000	1,900	0
TOTAL INDUCTEES	44,500	50,800	61,800

ADVANCED INDIVIDUAL TRAINING

BCT graduates must attend AIT before they can be deployed. As noted earlier in the report, it is not clear that all of the output from BCT can be accommodated in AIT. Some 21,000 TPU members are also expected to be awaiting the second part of the STO. They place an additional strain on the AIT capacity. Army training managers acknowledge that AIT capacity is an issue. They have also initiated actions to identify additional training resources for AIT.

EXPANEX '86 is a training base expansion exercise designed to test the feasibility of conducting selected AIT courses at Department of Labor Job Corps Centers during mobilization. By using Active and Reserve Component personnel for command, control, and basic military training, the Army hopes to use Job Corps Center staff members and facilities to increase AIT capacity. Although a small class of Administrative Specialists (MOS 71L) were successfully trained at a Job Corps Center in 1985, many administrative and logistical details of large scale use need to be tested. If the results of EXPANEX '86 (to be conducted from May through August 1986) are favorable, some Army officials speculate that AIT input capacity can be augmented by as much as 25,000.

OFFICER TRAINING

Mobilization will also affect the accession and training process for commissioned and warrant officers. Current senior cadets at the United States Military Academy will graduate at the normal time. The remaining three classes will undergo an accelerated 3-year, 48 week-per-year curriculum; upon graduation, these officers will attend OBC. ROTC cadets will also experience modified programs. Senior ROTC cadets will graduate as scheduled. Those nonsenior cadets who have completed advanced camp will be commissioned immediately and scheduled for OBC. All other contract cadets will be called to active duty as enlisted reservists en route to OCS, AIT, or BCT. Noncontract ROTC cadets are subject to SSS conscription. The warrant officer training strategy calls for everyone selected for appointment as warrant officer to complete a warrant officer entry course, followed by one of several technical certification courses. Preliminary figures indicate that the training base has the capacity to absorb these officer training inputs.

CONUS REPLACEMENT CENTERS

The subject of CRC is just beginning to receive attention and planning effort. Plans for providing an organizational structure for the first three centers at Fort Jackson, South Carolina; Fort Dix, New Jersey; and Fort Lewis, Washington are being accomplished by TRADOC. We are concerned that the planned administrative and logistical processing responsibilities now assigned to the CRCs may overburden the centers and cause a major delay in the flow of manpower to units. Additionally, plans for acquiring and stockpiling individual equipment and weapons are not clear.

6. RECOMMENDATIONS

GENERAL

Although the Army has developed a logical procedure for meeting its responsibilities for mobilization manpower planning and is constantly striving to improve these methods, we have noted areas that require attention. In this chapter, we present a revised inductee delivery schedule for the first 3 months following mobilization and suggest a conceptual model that will support planning efforts of both OSD and the Army. Recommendations designed to improve specific features of the existing system are also discussed.

INDUCTEE DELIVERY SCHEDULE

The current schedule which calls for the SSS to deliver up to 80,000 inductees during the first 30 days following mobilization exceeds the Army's capability to train inductees by almost 80 percent. *We recommend that Assistant Secretary of Defense (Force Management and Personnel) [ASD(FM&P)] ask the Director, SSS to reduce the number of inductees scheduled to be delivered to the Army to:*

- *First month: 44,500*
- *Second month: 50,800*
- *Third month: 61,800.*

The ASD(FM&P) should ask also that the Secretary of the Army adopt the schedule listed above as the Army's inductee requirement for the first 3 months following mobilization.

A CONCEPTUAL MODEL

Better analytical tools are needed to evaluate the large number of interrelated variables relevant to manpower mobilization planning. Even the most basic analysis of the enlisted personnel accession system involves programming five sources of

accessions along multiple paths through several types of processing and training centers. There exists no effective method for evaluating this complex system.

We recommend that the ASD(FM&P) develop an integrated network model that characterizes the complex interactions between the various sources of personnel, processing centers, and training institutions. Further, we recommend that the ASD(FM&P) request Army participation in the development of the model in order to incorporate work currently being done within the Army and to ensure that the model is capable of accommodating the varying levels of detail required by different agencies. In the Appendix, we propose a concept for a network flow model to serve this purpose.

THE CURRENT SYSTEM

Structure Requirements

The attention being devoted to maintaining MOBTDAs is not uniform across the Army. The Army can encourage installations to allocate sufficient resources to produce more current and accurate documents by institutionalizing a more frequent update requirement. *We recommend that the Army require that all MOBTDAs be updated with the same semiannual frequency as the peacetime TDA.*

The Army should also continue the regular process for updating the Mobilization Logistical Structure and Composition System in order to improve the reliability of equippable COMPO 4 requirements.

Trained Manpower Supply

All of the categories of personnel that must be considered in mobilization planning are closely related and variations in one category can cause marked changes in several others. A single integrated system is needed to ensure that all factors are considered in a consistent, logical manner. *We recommend that the Army develop a single integrated system for providing personnel inventories used in mobilization planning. Since the FORECAST System, when complete, will fulfill this need, we recommend continued support for the project and adoption of each FORECAST*

subsystem for mobilization planning as each subsystem is delivered and accepted by the Army.

Plans for Untrained Troop Program Unit Members

Current plans call for TPU members who are awaiting training to report to mobilization stations with their units, be identified as untrained assets, and then be scheduled for and transported to the appropriate training. This plan could delay the start of training for some individuals by up to 60 days. The Reserve Components monitor the status of their unit members and have detailed information on their training status. A program is underway to establish a Reserve Component analog to the Active Component TTHS account. *We recommend that the Army develop a program that will assign TPU members awaiting training directly to designated RECSTA in the event of mobilization.*

Plans for Pretrained Individuals in Overage Specialties

The latest projections indicate that combat support, maintenance, and other skills will have significant personnel overages by M + 90, while combat specialties will be critically short. At this time there is no plan to utilize the individuals in overage specialties to help offset the shortage specialties. A coordinated retraining/skill substitution program is needed to help provide more realistic personnel inventory projections and help alleviate the projected shortage in combat specialties. *We recommend that the Army formulate a plan to account for and utilize personnel in overage specialties.*

CONUS Replacement Centers

Existing plans assign extensive administrative and logistical processing responsibilities to the CRCs. We believe that the centers are understaffed and inadequately supplied to accomplish their mission in a timely manner. At a minimum, an exercise should be conducted to test the capabilities of one or more centers. *We recommend that the Army reassess the CRC concept.*

APPENDIX

A CONCEPTUAL MODEL

BACKGROUND

Mobilization manpower planning is a complex process. Planners must contend with parameters that not only display high degrees of variance but are also inter-related in very intricate ways. Because of this inherently uncertain and involved environment, we feel that modeling efforts must strive to achieve the flexibility to analyze variables either separately or as part of the complete process. Both the overall mobilization manpower personnel accession process and the Army mobilization training system can be viewed as networks. After providing a basic introduction into the theory of network modeling, we describe an application of the theory to the *mobilization manpower accession and training base system*.

NETWORK MODELS

One application that gives rise to a network model is a materials flow process in which materials must move through specific channels whose capacities are restricted. Figure A-1 depicts an example of such a network. The numbered circles or nodes represent sources of material (nodes 1, 2, 3, 4, 5) or processes (nodes 6, 7, 8, 9, 10, 11, 12, 13) and the arrows or directed arcs indicate paths for potential flow. Variables X_1 through X_{15} are the quantities of material flowing along the path. For example, X_2 is the quantity flowing from source 2 to process 6. Many different features of the flow process can be studied from this representation.

We first assign capacities to each of the arcs based upon our knowledge of the process. In our example, the maximum capacities for each arc are: $X_1=5$, $X_2=8$, $X_3=3$, $X_4=4$, $X_5=10$, $X_6=3$, $X_7=6$, $X_8=7$, $X_9=11$, $X_{10}=3$, $X_{11}=8$, $X_{12}=9$, $X_{13}=7$, $X_{14}=10$, $X_{15}=12$. Suppose we wish to determine the maximum material

FIGURE A-1. EXAMPLE OF MATERIALS FLOW NETWORK

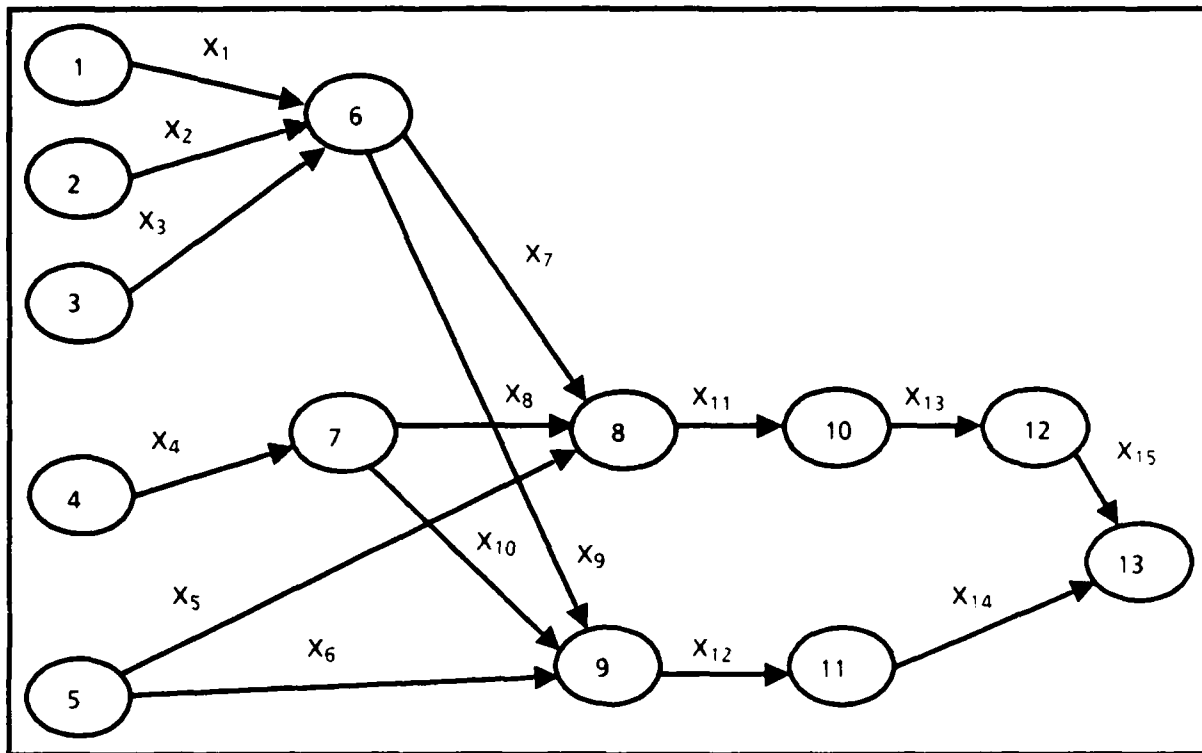

flow through the network. Since the output comes only from X_{14} and X_{15} , we want to: Maximize $X_{14} + X_{15}$.

We will call this our objective function.

The maximum flow is limited or constrained by the capacities of each of the arcs. There will be 15 constraints of the type $X_i \leq 5$, which indicates that the flow from source 1 to process 6 cannot exceed the maximum capacity on that arc. Conservation of flow (flow-in equals flow-out) must also be preserved. At process 6, for example, this means that $X_1 + X_2 + X_3$ (in flow) equals $X_7 + X_9$ (out flow). The equation can be written:

$$X_1 + X_2 + X_3 = X_7 + X_9 \text{ or } X_1 + X_2 + X_3 - X_7 - X_9 = 0.$$

There are seven equations of this type. Combining all of these constraints, the model takes the form shown in Figure A-2.

FIGURE A-2. MOBILIZATION MODEL FORMULATION

Maximize					$X_{14} + X_{15}$	
Subject to:	X_1					≤ 5
	X_2					≤ 8
	X_3					≤ 3
	X_4					≤ 4
	X_5					≤ 10
	X_6					≤ 3
	X_7					≤ 6
	X_8					≤ 7
	X_9					≤ 11
	X_{10}					≤ 3
	X_{11}					≤ 8
	X_{12}					≤ 9
	X_{13}					≤ 7
	X_{14}					≤ 10
	X_{15}					≤ 12
	$X_1 + X_2 + X_3$		$-X_7$	$-X_9$		$= 0$
	X_4		$-X_8$	$-X_{10}$		$= 0$
	X_5		$+X_7 + X_8$	$-X_{11}$		$= 0$
	X_6		$+X_9 + X_{10}$	$-X_{12}$		$= 0$
			X_{11}	$-X_{13}$		$= 0$
			X_{12}	$-X_{14}$		$= 0$
			X_{13}	$-X_{15}$		$= 0$

The model has been formulated as a linear program and is readily solved by any of the software packages available for use on personal computers. By solving this program, we learn that the maximum flow possible is 16 with $X_{14}=9$ and $X_{15}=7$.

APPLICATION OF NETWORKS TO MOBILIZATION PLANNING

Our previous example was solved without mentioning the specific material that was flowing in the network. In Figure A-3 we have redrawn Figure A-1, and replaced the numbers on the nodes with titles for sources of untrained manpower and mobilization processes. The network now represents a simplified version of the mobilization enlisted manpower accession process. The flows on the arcs are the numbers of the different types of untrained manpower over some period, say the first 180 days following mobilization. The capacities from the example would be replaced with the actual populations and process capacities used in mobilization planning. Clearly Figure A-3 is too simple to provide full planning utility. But even in this simple form there are many appealing features. First, the planner is forced to consider the process interrelationships and key parameters more fully. Also, impacts that would occur from changing these interrelationships and parameters can be readily examined. Next, the model can receive and provide data to existing systems leading to a more consistent and integrated planning process. Mobilization Manpower Planning System (MOBMAN) could be used to determine the output requirements for X_{14} and X_{15} . In a similar way Mobilization Training Capacity Requirements Determination System (MOBTRAC), or its counterpart, could provide the capacity limits for the training processes. Finally, the objective function and constraints can be tailored to study different aspects of the mobilization process. Rather than maximizing output, we could set the required output and seek or determine the minimum capacities needed to support this output level.

FIGURE A-3. THE ARMY MOBILIZATION ENLISTED MANPOWER PERSONNEL ACCESSION SYSTEM

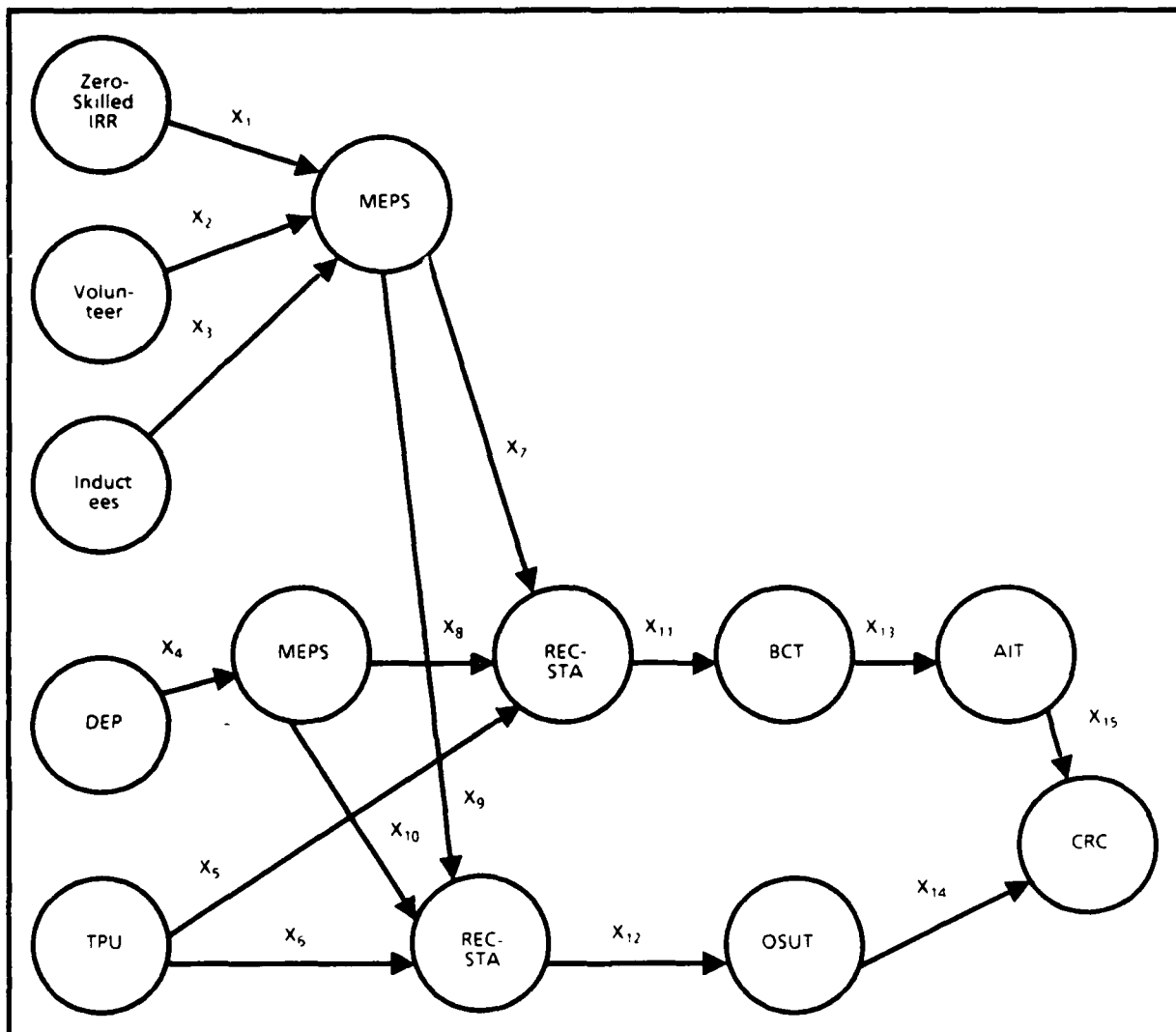

NOTE. IRR = Individual Ready Reserve, MEPS = Military Entrance Processing Station; DEP = Delayed Entry Program, RECSTA = Reception Station; BCT = Basic Combat Training, AIT = Advanced Individual Training; TPU = Troop Program Unit; OSUT = One Station Unit Training; CRC = CONUS Replacement Center

EXPANDING THE MODEL

Our initial network model of the mobilization manpower process is designed to provide an aggregate personnel figure for a 180-day period. Both of these broad objectives can be refined or adjusted. Using the same principles and techniques, the single processes for Basic Combat Training (BCT), One Station Unit Training (OSUT), and Advanced Individual Training (AIT) can be decomposed to study

training site or, for AIT, even individual course detail. The requirements for individual Military Entrance Processing Station (MEPS) and reception station (RECSTA) could be similarly provided. Additional paths for special groups, like veteran volunteers, may be added. Even the course attrition rates can be reflected by adjusting the coefficients of the variables in the conservation of flow constraints.

Figure A-4 shows how finer time resolution is possible. In this case we have modeled the flow for two, 10-day periods. This model could be used to analyze the inputs over the first 20 days following mobilization and to determine how these inputs relate to output demand in the future. An alternative to including the additional nodes is to keep the same network as in Figure A-3 and use the network for consecutive periods with the outputs from an earlier time feeding the following period.

Training base capacity can be studied in the same manner as the overall mobilization manpower process. First, the RECSTA-BCT-OSUT-AIT portion of Figure A-3 would be isolated. Then a more detailed view of the training network could be depicted by incorporating the structure, personnel, facility, and equipment constraints of the training base into the model. The time and individual site detail can also be defined to the required level.

The level of detail and types of analyses that can be performed are limited only by the imagination of the modeler. Generally, a rather simple process is developed first. Then, as determined by needs or desires, more sophisticated and complex systems evolve. More involved models do require more variables and constraints. This tradeoff between detail and ease of solution must be a consideration during model development.

SUMMARY

The proposed conceptual model is designed to supplement, not replace the current mobilization manpower planning system. Since the transition from peacetime to mobilization requires multiagency and multioffice coordination, it is important to have a planning mechanism that can be tailored to accommodate the broad policy initiatives of Office of the Secretary of Defense as well as the more detailed personnel planning issues that concern the Army. Further, the mobilization manpower planning process involves parameters that are subject to such variation and are interrelated in such complex ways that is imperative to be able to analyze them both separately and as a part of the total process. The network model described above is a flexible tool that meets these requirements. It is capable of virtually any level of detail desired; can readily interface with existing and developing systems such as the 1322 System, the MOBMAN, and the MOBTRAC; and serves to integrate the entire mobilization manpower planning function. The proposed model is in concert with the theme of the Systems Research and Applications Corporation report, A Requirements Analysis for Managing the National Accession Process During Mobilization, and could be a component part of their future work.¹

¹The draft report identified critical missing links in the management of the accession process during mobilization. The report also called for the establishment of a formal system for information flows between agencies. The conceptual model described above will not only encourage such information exchange, but will provide a forum for the exchange to take place.

REPORT DOCUMENTATION PAGE

1a. REPORT SECURITY CLASSIFICATION Unclassified		1b. RESTRICTIVE MARKINGS	
2a. SECURITY CLASSIFICATION AUTHORITY		3. DISTRIBUTION / AVAILABILITY OF REPORT "A" Approved for Public Release; distribution unlimited.	
2b. DECLASSIFICATION / DOWNGRADING SCHEDULE			
4. PERFORMING ORGANIZATION REPORT NUMBER(S) LMI Task FP601		5. MONITORING ORGANIZATION REPORT NUMBER(S)	
6a. NAME OF PERFORMING ORGANIZATION Logistics Management Institute	6b. OFFICE SYMBOL (if applicable)	7a. NAME OF MONITORING ORGANIZATION	
6c. ADDRESS (City, State, and ZIP Code) Logistics Management Institute 6400 Goldsboro Road Bethesda, Maryland 20817-5886		7b. ADDRESS (City, State, and ZIP Code)	
8a. NAME OF FUNDING / SPONSORING ORGANIZATION ASD(FM&P)	8b. OFFICE SYMBOL (if applicable)	9. PROCUREMENT INSTRUMENT IDENTIFICATION NUMBER MDA903-85-C-0139	
8c. ADDRESS (City, State, and ZIP Code) Office of the Assistant Secretary of Defense (Force Management and Personnel)		10. SOURCE OF FUNDING NUMBERS	
		PROGRAM ELEMENT NO	PROJECT NO
11. TITLE (Include Security Classification) The Army Mobilization Manpower Accession System			
12. PERSONAL AUTHOR(S) Dayton S. Pickett, John T. Durgala, and David V. Glass			
13a. TYPE OF REPORT Final	13b. TIME COVERED FROM _____ TO _____	14. DATE OF REPORT (Year, Month, Day) August 1986	15. PAGE COUNT 49
16. SUPPLEMENTARY NOTATION			
17. COSATI CODES		18. SUBJECT TERMS (Continue on reverse if necessary and identify by block number) Mobilization, Inductee, Manpower Planning	
FIELD	GROUP		
19. ABSTRACT (Continue on reverse if necessary and identify by block number) <p>This report addresses the Army's current system for accession of personnel during mobilization, with emphasis on the process for acquiring and training inductees during full mobilization. In the initial stages of a major conflict the demand for trained Army manpower will exceed the supply. The schedule for inductee delivery is a key element of the Army's mobilization manpower plan since manpower demand will not be satisfied until there is sufficient opportunity to acquire and train these additional personnel.</p> <p>Basic time-phased demand and supply analysis is the foundation of the Army mobilization manpower process. First, the total demand for manpower, consisting of force structure requirements, casualty estimates, and a personnel overhead account is established. Next, the supply of pretrained individual manpower available to meet this demand is determined. Results from this demand and supply analysis provide estimates for the number of inductees required as well as training goals for the Army training base. In performing this process, the Army must use estimates for such factors as combat casualties, available manpower, and training capabilities. These factors are highly sensitive to changes in policy and the cyclic fluctuations of the personnel inventory and are also interrelated in complex ways.</p> <p>Although the Army has steadily improved its mobilization manpower planning process, recognized shortcomings that affect the inductee schedule continue to exist. In some cases, a hasty and incomplete staffing process is used to develop the mobilization requirements for manpower. Projections for combat casualties are generated by models that use overly simplified assumptions and require large amounts of input data that are difficult to manage.</p>			
20. DISTRIBUTION / AVAILABILITY OF ABSTRACT <input checked="" type="checkbox"/> UNCLASSIFIED/UNLIMITED <input type="checkbox"/> SAME AS RPT <input type="checkbox"/> DTIC USERS		21. ABSTRACT SECURITY CLASSIFICATION	
22a. NAME OF RESPONSIBLE INDIVIDUAL		22b. TELEPHONE (Include Area Code)	22c. OFFICE SYMBOL

19.

There is no standard source of data or integrated system for projecting personnel inventories. No provisions have been made to utilize individuals in specialties that are expected to be excess to the needs of the Army during mobilization.

We recommend that the Assistant Secretary of Defense (Force Management and Personnel) take the following actions:

- Request that the Army revise its requirement for inductees during the first 3 months following mobilization to: first month, 44,500; second month, 50,800; third month, 61,800.
- Initiate, in conjunction with the Army, actions to develop a mathematical model for use in mobilization manpower planning. A concept for the model, which is designed to accommodate varying levels of detail, integrate all aspects of mobilization manpower planning, and incorporate work currently being done within the Army and the Office of the Secretary of Defense; is described in this report.
- Encourage the Army to require the semiannual update of all mobilization manpower requirement documents.
- Encourage the Army to formulate or modify plans to utilize personnel in overage specialties and more effectively schedule untrained Troop Program Unit members for initial training.
- Encourage the Army to continue the ongoing efforts to improve the combat casualty estimation process and to develop a single source of personnel inventory projections.

END

1-87

DTIC