

AD-A174 905

ELECTROCHEMISTRY IN NEAR-CRITICAL AND SUPERCRITICAL
FLUIDS 4 NITROGEN HET (U) TEXAS UNIV AT AUSTIN DEPT OF
CHEMISTRY R M CROOKS ET AL SEP 86 N00014-84-K-0428

1/1

UNCLASSIFIED

F/G 7/3

NL

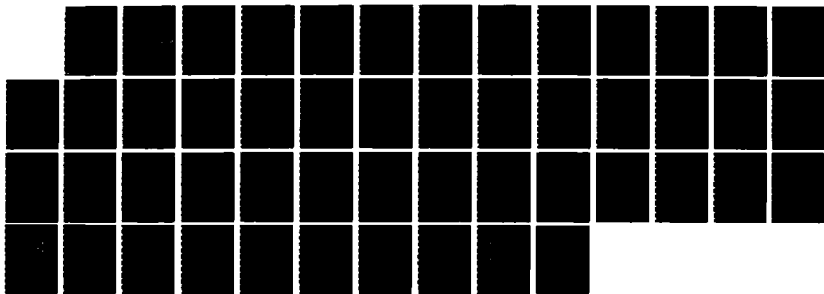

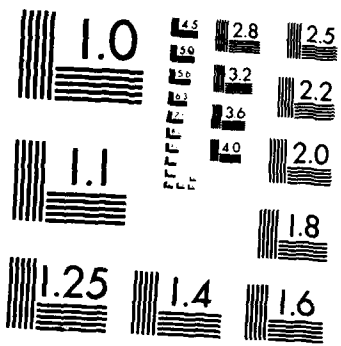

XEROCOPY RESOLUTION TEST CHART
 NATIONAL BUREAU OF STANDARDS-1963-A

AD-A174 905

2

OFFICE OF NAVAL RESEARCH
Contract N00014-84-K-0428
Task No. NR 051-693
TECHNICAL REPORT No.

Electrochemistry in Near-Critical and Supercritical Fluids. 4.
Nitrogen Heterocycles, Nitrobenzene, and Solvated Electrons
in Ammonia at Temperatures to 150⁰ C.

by

Richard M. Crooks and Allen J. Bard
Department of Chemistry, University of Texas
Austin, Texas 78712

Prepared for Publication
in
Journal of Physical Chemistry

The University of Texas at Austin
Department of Chemistry
Austin, Texas 78712

DTIC
ELECTE
DEC 8 1986
S B D

Reproduction in whole or in part is permitted for
any purpose of the United States Government.

This document has been approved for public release
and sale; its distribution is unlimited.

DTIC FILE COPY

REPORT DOCUMENTATION PAGE		READ INSTRUCTIONS BEFORE COMPLETING FORM
1. REPORT NUMBER	2. GOVT ACCESSION NO. ADA 174905	3. RECIPIENT'S CATALOG NUMBER
4. TITLE (and Subtitle) Electrochemistry in Near-Critical and Supercritical Fluids. 4. Nitrogen Heterocycles, Nitrobenzene, and Solvated Electrons in Ammonia at Temperatures to 150° C.		5. TYPE OF REPORT & PERIOD COVERED
		6. PERFORMING ORG. REPORT NUMBER
7. AUTHOR(s) Richard M. Crooks and Allen J Bard		8. CONTRACT OR GRANT NUMBER(s) N00014-84-K-0428
9. PERFORMING ORGANIZATION NAME AND ADDRESS Department of Chemistry University of Texas at Austin Austin, TX 78712		10. PROGRAM ELEMENT, PROJECT, TASK AREA & WORK UNIT NUMBERS
11. CONTROLLING OFFICE NAME AND ADDRESS Office of Naval Research 800 N. Quincy Arlington, VA 22217		12. REPORT DATE
		13. NUMBER OF PAGES
14. MONITORING AGENCY NAME & ADDRESS (if different from Controlling Office)		15. SECURITY CLASS. (of this report) Unclassified
		15a. DECLASSIFICATION/DOWNGRADING SCHEDULE
16. DISTRIBUTION STATEMENT (of this Report) This document has been approved for public release and sale; its distribution is unlimited.		
17. DISTRIBUTION STATEMENT (of the abstract entered in Block 20, if different from Report)		
18. SUPPLEMENTARY NOTES Prepared for publication in the Journal of Physical Chemistry		
19. KEY WORDS (Continue on reverse side if necessary and identify by block number) pyrazine, quinoxaline, cyclic voltammetry		
20. ABSTRACT (Continue on reverse side if necessary and identify by block number) The electrochemistry of pyrazine, quinoxaline, phenazine and solvated electrons in near-critical and supercritical ammonia was investigated by cyclic voltammetry and Chronoamperometry and compared to that in liquid ammonia at -40° C. The reductions of pyrazine, quinoxaline and phenazine at room temperature, and in the supercritical fluid (SCF), occur reversibly or quasi-reversibly and result in stable products (anion radicals or dianions) on the voltammetric time scale. The electrochemistry of nitrobenzene was investigated in the presence of water, and reactions of the dianion at higher temperature, similar to those previously reported at -40° C were observed. The diffusion coefficient of the four aromatics increased.		

DD FORM 1473
1 JAN 73

EDITION OF 1 NOV 68 IS OBSOLETE
S/N 0102-014-6601

Unclassified
SECURITY CLASSIFICATION OF THIS PAGE (When Data Entered)

(OVER)

ABSTRACT CONT.:

BY AN ORDER OF MAGNITUDE BETWEEN -40°C AND 150°C IN AGREEMENT WITH THE STOKES-EINSTEIN RELATIONSHIP OVER THE TEMPERATURE RANGE STUDIED. SOLVATED ELECTRONS WERE ELECTROCHEMICALLY GENERATED IN THE SUPERCRITICAL FLUID AND FOUND TO BE STABLE ON THE VOLTAMMETRIC TIME SCALE. THE THERMODYNAMICS OF ELECTRODE REACTIONS IN THE SCF IS DISCUSSED, AND THE APPARATUS FOR PERFORMING ELECTROCHEMISTRY IN THE SCF IS DESCRIBED.



Approved for	
By	
Distribution	
Availability	
Classification	
Control	
A-1	

Electrochemistry in Near-Critical and Supercritical Fluids. 4.
Nitrogen Heterocycles, Nitrobenzene, and Solvated Electrons
in Ammonia at Temperatures to 150° C.

Richard M. Crooks and Allen J. Bard
Department of Chemistry, University of Texas
Austin, Texas 78712

ABSTRACT

The electrochemistry of pyrazine, quinoxaline, phenazine and solvated electrons in near-critical and supercritical ammonia was investigated by cyclic voltammetry and chronoamperometry and compared to that in liquid ammonia at -40° C. The reductions of pyrazine, quinoxaline and phenazine at room temperature, and in the supercritical fluid (SCF), occur reversibly or quasi-reversibly and result in stable products (anion radicals or dianions) on the voltammetric time scale. The electrochemistry of nitrobenzene was investigated in the presence of water, and reactions of the dianion at higher temperature, similar to those previously reported at -40° C were observed. The diffusion coefficient of the four aromatics increased by an order of magnitude between -40° C and 150° C in agreement with the Stokes-Einstein relationship over the temperature range studied. Solvated electrons were electrochemically generated in the supercritical fluid and found to be stable on the voltammetric time scale. The thermodynamics of electrode reactions in the SCF is discussed, and the apparatus for performing electrochemistry in the SCF is described.

Submitted to J. Phys. Chem.

September 1986

INTRODUCTION

Our laboratory has been engaged in extracting quantitative electrochemical information from species in supercritical fluids (SCF).^{1,2} In this article we report the cyclic voltammetry and chronoamperometry of a series of aza-aromatic compounds (pyrazine, quinoxaline, and phenazine), nitrobenzene, and the generation of solvated electrons in near-critical and supercritical ammonia. We have investigated the thermodynamics, mass transport, and chemical stability of these species and show, for the first time, electrochemistry of organic species in supercritical ammonia. Supercritical fluids have interesting solvating characteristics and provide greatly increased mass transfer rates; the results reported here, to our knowledge, represent the highest rates of diffusion to an electrode in an electrochemical system. We also describe details about the experimental apparatus required for high pressure/high temperature electrochemistry in ammonia.

The useful properties of near-critical and supercritical fluids are temperature and pressure induced. As the temperature of a liquid is increased along its characteristic vapor pressure curve, the thermodynamic properties change in a predictable way; for example, the dielectric constant (ϵ) and density (ρ) fall due to a loss in orientation polarization brought about by thermal randomization. The physical properties of the vapor change in an opposite way: as the temperature increases, ϵ and ρ increase. At the critical temperature, T_c , the thermodynamic nature of the vapor and liquid phases become indistinguishable and therefore cannot support a phase boundary. Above T_c , the thermodynamic properties of the SCF become very sensitive to pressure variations, since the fluids are readily compressed. For example, ϵ and ρ are continuously variable over a broad range with

relatively small changes of pressure. Since these parameters are in large part responsible for solvation characteristics, the primary goal of SCF research has been to understand and utilize the tunable solvating power of these fluids. The thermodynamic and experimental particulars of polar SCF have been reviewed elsewhere.^{3a,6}

The range of temperatures we used for electrochemical studies in ammonia and the physical properties of NH_3 at these are given in Table 1.³⁻⁵ In principle any ϵ , ρ or viscosity (η) is achievable for fluids above T_c ; however, present experimental limitations have restricted our study to roughly the range of values shown. The motivation for using ammonia as an electrochemical solvent has been either to provide an aprotic environment to study radical anions or other unstable intermediates, or to take advantage of the low working temperature of liquid ammonia to slow the kinetics of chemical reactions.⁷ We show here that the low acidity of ammonia is not changed greatly above T_c , and therefore that ammonia remains a useful medium for the study of such phenomena, even under high temperature and high pressure conditions. We have been able to study the same types of reactions which have previously been studied at low temperature, but with far more control over the nature of the solvent. Reliable measurements of electrode processes and diffusion above room temperature, such as those reported here, will provide heretofore unavailable thermodynamic information about electron transfer reactions and the nature of solvation and structure within the SCF. In addition, variation of the dielectric constant and density of supercritical ammonia may allow control over the position of equilibrium in electrosyntheses and simultaneously permit clean separation of product from solvent.

EXPERIMENTAL

High pressure apparatus. Construction details of the high pressure

apparatus, electrochemical cell, and electrodes are shown in Fig. 1. All homebuilt sections of the apparatus followed traditional construction techniques for high pressure and high temperature applications.⁸ The cell was of 314 stainless steel and had a volume of about 7 mL; the total volume of the apparatus during experiments was ca. 20 mL. Stainless steel is resistant to corrosion by ammonia and all other chemicals used in the temperature domain of these experiments; however, the oxides that readily form on the surface of austenitic stainless steels are soluble in ammonia, especially above 100° C. These surface passivating oxides, which are crucial to the integrity of stainless steel in aqueous environments, were minimized by allowing the cell to contact a powerful reducing agent (dithionite anion in water) prior to each experiment. Nonetheless, small currents due to the anodic stripping of these metals were occasionally observed in cyclic voltammograms. Recently a new cell has been fabricated of Inconel 600, a high nickel alloy which is impervious to surface oxidation. The cell was machined from a cylinder 2.5 inches in diameter and 3 inches in length. A 3/8 inch bore was drilled along the longitudinal axis and tapped at either end to accept commercial high pressure fittings. Similar threads were tapped perpendicular to the central bore midway from the ends to accommodate the electrode feedthroughs. Electrodes were held in place with taper seal high pressure fittings (High Pressure Equipment, Co., Erie, PA); the distance between working and reference electrodes was always less than 0.3 cm. The experiments described here were performed with an electrode geometry like that shown in Fig. 1b. This configuration could lead to contamination of the working solution by species generated at the counter electrode. More recently we have improved this design by using platinum and tungsten ultramicroelectrodes (diameter 10-100 μm), which reduce the current and thus electrogenerated contaminants. Details of this

improved apparatus and results using it will be described in forthcoming papers. The use of unlined metallic cells for electrochemistry can also lead to difficulties in potential control. The problems stem from stray currents that arise in a grounded system; therefore, care was taken to prevent contact of the high pressure system with earth ground.

The electrodes were constructed by passing a uranium glass-coated tungsten wire (0.040 inch diameter) through a commercially available Kovar to Pyrex seal (Ace Glass, Louisville, KY) and heating to collapse the Pyrex onto the glass-coated wire. The insulating high pressure seal is formed by the Pyrex/uranium glass seal. This assembly was soldered into a stainless steel tube. The exposed Kovar, which corrodes in ammonia, was electrochemically plated with silver. We have tested the design and found that the electrodes usually fail near 375 bar at 180° C, or 100 bar at 400° C. Tungsten has proven superior to traditional electrode materials for electrochemistry in ammonia, because it does not catalyze background reactions. For example, the reduction of protons to hydrogen has a 0.5 V overpotential on tungsten as compared to platinum.

The valves, tubing, pressure generator, and fittings were either of 316 or 304 stainless steel (High Pressure Equipment Co., Erie, PA). The pressures reported were measured by a strain gauge pressure transducer (Omega Engineering, Inc., Stamford, CT) in conjunction with a digital voltmeter (Doric, San Diego, CA). The temperature was measured by a stainless steel sheathed internal thermocouple placed within 0.5 cm. of the working electrode. Reported temperatures are within $\pm 2^\circ$ C, and pressures, within ± 4 bar. All heated regions of the apparatus were safety-shielded by 1/4 inch steel. The low temperature data were collected using apparatus similar to that previously described.^{7b}

Chemicals. Electronics grade nitrobenzene (Kodak, Rochester, NY) was used as received. Quinoxaline (Lancaster Synthesis, Windham, NH) phenazine, and pyrazine (Aldrich Chemical, Milwaukee, WI) were vacuum sublimed from molecular sieves two or three times and stored in an inert atmosphere. Ammonia (Matheson, anhydrous grade) was distilled twice from sodium prior to use to remove traces of O_2 and H_2O . In all high temperature experiments the potassium salt of trifluorosulfonic acid (CF_3SO_3H) was used as indifferent electrolyte. The acid (3M Corp., Minneapolis, MN) was neutralized with potassium carbonate, and recrystallized three times from acetone. The resulting crystals were dried in vacuum for 2 days at $130^\circ C$, rinsed in liquid ammonia, and dried again in vacuum for 12 h at $130^\circ C$ before storing in an inert atmosphere box. Potassium trifluorosulfonate was found to be superior to other electrolytes, since it provided relatively low solution resistance (low ion-pairing) in the SCF, and is electroinactive within the potential limits of ammonia.

Procedure. The working solution was prepared by adding the electrolyte (0.20 M CF_3SO_3K at $25^\circ C$, falling to 0.14 M in the SCF because of the decrease in density of ammonia) to a 75 mL stainless steel sample vial in an inert atmosphere box. The vial was attached to the vacuum line and ammonia of a measured volume was distilled into it. The tungsten disk working electrode (area = 0.0083 cm^2) was polished with 1 μm diamond paste (Buehler, Evanston, IL) rinsed in ethanol, and wiped dry; the silver quasi-reference electrode (Ag-QRE) was polished with sandpaper, rinsed, and dried; the platinum gauze counter electrode was briefly soaked in HNO_3 , rinsed, and dried. The entire apparatus and cell were flushed with ammonia from a solvent reservoir (S2), then dried under vacuum overnight. The sample vial (S1) was attached to the high pressure line and the solution was forced into the cell by gentle heating.

The temperature of the cell was controlled by a digital temperature controller (Omega Engineering, Stamford, CT) attached to a heating tape wrapped around the exterior of the cell. The pressure was adjusted either by venting small amounts of solution as the temperature rose or by adjusting the pressure generator (PG). The concentration of electroactive species was calculated from the initial concentration at -78°C and the density of ammonia at higher temperatures.³

Electrochemical measurements were made by cyclic voltammetry and chronoamperometry.⁹ A scan rate of at least 1 V/s was required for cyclic voltammetry to avoid convection, which was manifested as a plateau in the mass transfer limited region of the voltammogram. A forward step of 100 ms duration, to a potential at least 100 mV past the peak potentials found by cyclic voltammetry, was used for chronoamperometric measurements. Positive feedback iR-compensation was required to avoid potential control errors. For a typical peak current of 100 μA , the compensated potential amounted to 10 mV at 25°C or 40 mV at 150°C . Fig. 2 shows a plot of relative resistance, measured between the working and reference electrodes, versus temperature. The resistance measurements were done with a constant mass of ammonia. The increase in resistance reflects the rapid increase of the solution volume and resultant decrease in ρ near T_c . The sharply rising portion of the curve centered near T_c is caused by the reduction in ϵ of the solvent as it becomes supercritical and demonstrates that T_c is not substantially changed by the addition of electrolyte. The latter conclusion agrees with that of Silvestri et al.,¹⁰ for KI in supercritical ammonia.

Electrochemical Equipment. All electrochemical measurements were made using a Princeton Applied Research model 173 potentiostat/galvanostat and model 175 universal programmer. Data were collected on a Norland model 3001 processing digital oscilloscope.

Reference Potentials. Thermodynamically meaningful reference electrodes are difficult to construct for use at elevated temperature and pressure. There have been two strategies for dealing with the high temperature regime:¹¹ placement of a standard reference electrode directly within the high temperature solution or isolation of the reference electrode in a room temperature environment with a salt bridge contact to the working solution. There are difficulties with both of these approaches. In the case of the internal standard hydrogen electrode, a pressure of hydrogen must be maintained over a platinum substrate in such a way as to avoid contamination of the working solution. In water this has been accomplished up to 275° C for the calibration of secondary electrodes,^{11,12} but because of the unique characteristics of the supercritical phase, a suitable primary or secondary internal reference has, to our knowledge, not been devised. In the case of an external reference electrode one must accept unknown thermal, bridge, and liquid junction potential gradients, as well as large potential control errors in solutions with high resistance. Little quantitatively consistent success has been achieved in solution with large temperature differentials.

The Ag-QRE has many qualities which make it an excellent standard electrode for SCF: it is simple to build, rugged, and provides a stable reference potential for a sufficient length of time.¹³ In addition, it does not require an associated ion in solution. Such ions, especially halides, could be oxidized at the counter electrode of the one-compartment cell and subsequently interfere with reactions at the working electrode. Furthermore, most anion salts are of limited solubility in supercritical ammonia, or ion pair extensively and are of unknown and highly variable activity. For these reasons and for lack of a suitable alternative, the Ag-QRE was the reference electrode of choice for potential measurements in

ammonia and other SCF systems. As long as the potential of the QRE does not change during the measurement, its potential can be determined with respect to a more thermodynamically meaningful potential by the use of a reference redox couple. For example, in many nonaqueous solvents the ferrocene/ferrocenium couple is employed. In ammonia it is convenient to use the onset of solvated electron generation (e_s^-) as a reference. In our solution the potential for the Ag-QRE did not change (± 20 mV) in pure electrolyte versus the onset of e_s^- from 25° C to 150° C, and thus we report all potentials versus e_s^- . In pure electrolyte solutions a current density due to e_s^- of 24.1 mA/cm² occurred at -1.68 ± 0.02 V vs. Ag-QRE between 25° C and 150° C (scan rate=1 v/s). The electrochemical solvation of electrons in liquid ammonia is known to be a reversible process,^{27a} and Laitinen and Nyman¹⁴ found the "electron electrode" to be quite reliable. In addition Schindewolf and Werner¹⁵ found the potential of the electron electrode to be practically independent of temperature between -35° C and -75° C. The dianion of nitrobenzene precipitated onto the surface of the working electrode altering the thermodynamic potential for subsequent e_s^- formation. In that case potentials were obtained directly from the QRE, but reported versus e_s^- .

RESULTS AND DISCUSSION

Cyclic Voltammetric Reduction of Aza-aromatics. Cyclic voltammograms for pure supporting electrolyte at 25° C and 150° C are shown in Fig. 3a. No significant faradaic processes are observed from +2.1 V to +0.2 V (vs. e_s^-) at 25° C. However, in the SCF a small anodic wave near +1.7 is evident. This feature corresponds to the anodic stripping of trace metal impurities dissolved as oxides from the surface of the stainless steel cell. The results reported were not significantly affected by this process; recent

experiments in an Inconel cell do not show the metal stripping peak and give identical results to those reported here.

Initial experiments utilizing alkali halides, mainly KI, as supporting electrolytes in the SCF occasionally showed spurious currents, particularly near the positive potential limit in the presence of aromatic species. The limiting potential in these cases, +2.0 V at 150° C. was attributed to the oxidation of halide¹⁶ that was either reactive towards the electroactive species or could itself be reduced at the working electrode. No such interferences were observed in the presence of $\text{CF}_3\text{SO}_3\text{K}$, because the anodic background process, which begins +2.4 V at 150° C, is probably oxidation of NH_3 :



Care was taken to keep cell currents small so as to minimize contamination of the solution by H^+ , since it reacts with most of the species studied. The available potential window for electrochemistry in ammonia at -70° C is around 3.0 V. This range decreases to 2.6 V at 25° C and 2.2 V 150° C, presumably because of more facile kinetics of the anodic background process, eq. 1, at the higher temperatures.

The general electrochemical reaction scheme expected in aprotic media for the aza-aromatics is:¹⁷



However, a variety of reactions of R^- and R^{2-} that follow electron transfer reactions are known to occur (e.g., disproportionation, dimerization, and

synproportionation). In the presence of a proton source, particularly at elevated temperature, follow-up chemistry can occur which might complicate the simple stepwise electron transfer mechanisms shown in eqs. 2 and 3.

Typical voltammograms of the nitrogen heterocycles pyrazine (PYR), quinoxaline (QUIN), and phenazine (PHEN) at 25° C and 150° C are shown in Fig. 3b-d. The data derived from these voltammograms are summarized in Table 2. For a stable reaction product produced by a reversible electron transfer the ratio of the peak anodic and cathodic currents ($i_{p,a}/i_{p,c}$) is equal to one. A ratio near unity was found experimentally for all of the aza-aromatics. In cyclic voltammetry the cathodic current function, $i_{p,c}/v^{1/2}$ C, where v is scan rate and C the bulk concentration, is constant for diffusion-controlled systems at different values of v . Experimentally the standard deviations of the current functions never exceeded 5% at 25° C or 10% at 150° C for scan rates of 1 to 20 V/s. The values for ΔE_p ranged from 76-94 mV at 25° C and from 116-150 mV at 150° C (compared to theoretical nernstian one-electron values of 59 and 84 mV, respectively).¹⁸ The potential of the peak cathodic current, $E_{p,c}$, shifted slightly in a negative direction with scan rate especially in the SCF.

The current-based diagnostics indicate the product of the electrochemical process occurring at the potential of the first wave for QUIN and PHEN is stable. The potential dependent measurements suggest a reversible electron transfer, but at fast scan rates vary somewhat from ideality, particularly in the SCF. These deviations from the theoretical values of the potential diagnostics are due to uncompensated solution resistance, especially at rapid scan rates, rather than real deviations of the electrode reactions from nernstian behavior. Recent experiments with ultramicroelectrodes (area ca. 10^{-5} cm²) have shown that ΔE_p for the first reduction of PHEN is constant at v up to 50 V s⁻¹. Based on the evidence

presented in Table 2 and supporting evidence from chronoamperometric data to be discussed later, the first waves of PHEN and QUIN, in liquid and supercritical ammonia, are assigned to one-electron reversible processes as shown in eq. 2. The value of ΔE_p is significantly larger for PYR than for either QUIN or PHEN. This might represent a limitation of the heterogeneous electron transfer rate; therefore, the reduction of PYR is quasi-reversible.

No second reduction was noted for PYR even in experiments performed at -40°C . A second voltammetric wave was observed at 25°C for QUIN, but it faded into the cathodic background process at 100°C . At both room temperature and in the SCF two waves were present for the reduction of PHEN. The experimental parameters derived from cyclic voltammetry for the second reductions of QUIN and PHEN at 25°C and 150°C are shown in Table 2.

At 25°C the voltammetric diagnostics for the second wave of QUIN are consistent with that of the first, and by similar arguments, it is assigned as a reversible, one-electron transfer. The slightly high value of $i_{p,a}/i_{p,c}$ usually is suggestive of a surface process such as adsorption or precipitation, but is attributed here to the difficulty of measuring the peak current of a second cyclic voltammetric wave.¹⁹ In those cases where a second wave is present in the voltammetry, the current function for the second wave is slightly smaller than that of the first. Theoretically, if both waves represent reversible electron transfer, the current function should be the same. The aforementioned difficulty of measuring $i_{p,c}$ for the second wave accounts for this inconsistency.

The utility of ammonia as an aprotic solvent is especially evident in the case of PHEN, which shows a well-developed second wave even in the SCF. At 25°C this wave is reversible, and even at 150°C , the current function, $i_{p,a}/i_{p,c}$, and ΔE_p point to Nernstian behavior. Previous work has demonstrated the unique stability of the radical anions and dianions of

nitrobenzene and benzophenone in liquid ammonia at -40°C .^{7a-c} It has been suggested that this stability was mainly due to the low temperature of the solvent, but slow sweep voltammetry in the SCF at 150°C shows the dianion of PHEN (PHEN^{2-}) to have a half-life ($t_{1/2}$) in excess of 0.5 min, and initial coulometric measurements of the anion radical ($\text{PHEN}^{\cdot-}$) indicate $t_{1/2} > 3$ min. Based on these results we conclude the stability of $\text{PHEN}^{\cdot-}$ and PHEN^{2-} is due to intrinsic nature (i.e., low acidity) of ammonia rather than only to temperature effects.

Cyclic Voltammetric Reduction of Nitrobenzene. The electrochemistry of nitrobenzene (NB) in ammonia at -40°C has been elucidated in the absence and presence of weak and strong acids.^{7b} In the absence of an acid, two reversible one-electron transfers corresponding to eqs. 2 and 3 were found where $E_{p,c,1} = -0.44\text{ V}$ and $E_{p,c,2} = -1.26\text{ V}$ vs. Ag/AgI-QRE. With an available proton in solution, the voltammetry became more complicated and is discussed below. We have investigated those systems at elevated temperature and pressure in order to compare their behavior over a temperature range of nearly 200°C . Such information should be useful for extrapolating other low temperature data into the supercritical regime.

Figs. 4a-b show the voltammetry of the first reduction of NB at 25°C and 150°C , respectively. The diagnostic parameters derived from these voltammograms are collected in Table 2. The behavior of the first reduction of NB is quite similar to that of the first reduction at low temperature, except for the values of ΔE_p . At 25°C and 150°C ΔE_p was found to be nearly twice as high as the theoretical value for a reversible electron transfer; however, even at -40°C there was a 10% departure from the nernstian value. Since ΔE_p is significantly larger for the first reduction of NB than for that of either PHEN or QUIN at $v = 2\text{ V/s}$, and since the solution resistance should be the same in both cases, it must represent a

real deviation of the associated electron transfer reaction from reversibility. On the basis of work at -40°C , chronoamperometric data and, by analogy to arguments made for PYR, this reduction is assigned as a quasi-reversible one-electron transfer.

Fig. 4c shows the more complex voltammetric response of NB at 25°C when the potential is scanned past the first reduction. By analogy to the cyclic voltammetric behavior of NB at -40°C (ref. 7b, Fig. 3), two, one-electron waves are expected for this system; however, additional features are present. Particularly prominent are a small cathodic prewave at $+0.88\text{ V}$ and a shoulder on the first anodic wave centered at $+1.91\text{ V}$. The voltammogram shown in Fig. 4c can be explained by an inextirpable trace of water present in the high pressure apparatus which acts as a weak acid as was shown for the reduction of NB in liquid ammonia at -40°C (ref. 7b, Fig. 5). When water, which is a weak acid in ammonia, was intentionally added to the NB system at 25°C , the two anomalous waves present in Fig. 4c became larger, Fig. 4e.

The prewave at $+0.88\text{ V}$, Fig. 4c, is indicative of a following chemical reaction; in this case the protonation of the dianion of $\text{NB}(\text{NB}^{2-})$ by water.



After this step, NBH^{-} rapidly decomposes to OH^{-} and nitrosobenzene (PhNO). The latter is immediately reduced to PhNO^{2-} and takes on a proton to form PhNOH^{-} . Upon scan reversal the two oxidation waves of NB^{2-} at $+0.75\text{ V}$ and $+1.66\text{ V}$ dominate the voltammetry, but a slight broadening on the positive side of the anodic wave at $+0.75\text{ V}$ is evident, as is the small wave at $+1.91\text{ V}$. These features are due to the oxidation of PhNOH^{-} to PhNOH^{\bullet} (which deprotonates quickly to the radical anion) and further oxidation of PhNO^{-} to

PhNO.

The single difference between the voltammetry presented here and that of the previous study with isopropyl alcohol (IPA) as proton donor is the relative position of the prewave (Fig. 4c, at +0.88 V). At -40° C this prewave was shifted in a negative direction by 0.2 V relative to the following wave. Because water is a stronger acid than IPA in ammonia, such a shift is expected and reflects an increase in the equilibrium constant of eq. 4.

With the exception of the two small waves just discussed, the electrochemistry of NB at 25° C is found to be in qualitative agreement with the behavior found at -40° C in the absence of acid. Especially significant features present in the voltammetry at both 25° C and -40° C are the surface-like anodic wave at +0.75 V, which corresponds to the oxidation of precipitated NB^{2-} and the identical splitting between the two cathodic waves of 0.82 V. Therefore, the cathodic wave present at +0.68 V in the voltammetry of NB at 25° C must correspond to a quasi-reversible reduction of the radical anion of NB ($\text{NB}^{\cdot-}$) to the insoluble NB^{2-} salt.

The voltammetry at 150° C is substantially different than that at 25° C. Figs. 4d and 4f show the voltammetric response at 150° C, which corresponds to the two NB/H₂O voltammograms of Fig. 4c and 4e at a lower temperature. Fig. 4d shows that the prewave has shifted positive by an additional 0.2 V relative to the second reduction wave. The peak current of the second reduction near +0.48 V has more than doubled, relative to the first, and the anodic backwave associated with precipitation of NB^{2-} at 25° C is greatly reduced. In addition, the anodic wave due to the oxidation of PhNO^{\cdot} at 25° C is absent. This behavior is quite similar to that found at -40° C for the reduction of NB in the presence of a strong acid (Ref. 7b,

Fig. 8). In that case the mechanism was found to be analogous to that of the weak acid, except PhNOH^- added an additional proton to form neutral phenylhydroxylamine (PhNOH_2):



which can only be oxidized at potentials positive of the solvent limit at 150°C . We cannot give a complete quantitative explanation of the voltammetry of the NB system at 150°C at this time, but the evidence suggests that water in ammonia acts as a stronger acid toward NB^{2-} at 150°C than at 25°C . Little information is available on acid-base chemistry in ammonia at elevated temperatures,²⁰ and there have been no direct measurements of acidity as a function of temperature; however, there is ample indirect evidence that acidity should increase with temperature. First, the acidity of water and aqueous acids increases with temperature: for example, the autoprotolysis constant of water, K_w , increases by two orders of magnitude between 25°C and 150°C .²¹ Jolly²² calculated the equilibrium constant (K) for the reaction:



in NH_3 to be about 2×10^{-20} at 25°C based on thermodynamic estimates. Schindewolf and Schwab²³ measured K experimentally at -40°C and found it to be 6.3×10^{-22} . He suggested that the discrepancy in K was due in part to the uncertainty of the thermodynamic estimates, but also that the temperature difference of 65°C probably resulted in an increase of K by an order of magnitude.

The effect of an increase in the acidity of water is to increase the equilibrium concentration of NBH^- (eq. 4), and thus the magnitude of the

cathodic wave near +0.48 V (Fig. 4d). In addition, the positive shift of the cathodic prewave (+0.88 V, Fig. 4d) is also consistent with an increase in acidity. Additionally, more of the PhNOH^- should protonate to form PhNOH_2 , eq. 5, leading to the observed decrease in the anodic wave at +0.63 V and the absence of a current related to the oxidation of PhNO^- . At rapid scan rates ($v > 20$ V/s), the voltammetry of Fig. 4d approached that of Fig. 4c. This implies that the kinetics of eqs. 4 and 5 are sufficiently slow that the rate increase associated with the enhanced acidity of water can be offset by a decrease in the time frame of the experiment.

Diffusion Coefficients. The measured diffusion coefficients (D) of aromatics at 25° C and in the SCF are given in Table 2. These were obtained for potential steps past $E_{p,c}$ of the first, one-electron, wave and for the second wave ($n=2$) for PHEN. The integrated chronoamperometric behavior⁹ is shown in Fig. 5.

A uniform four-fold change in D is found between 25° C and 150° C, with about an order of magnitude change between -40° C and 150° C. This change can be compared to that predicted by various models (e.g., the Stokes-Einstein equation and the activated diffusion model) to draw conclusions regarding the structure of near-critical and supercritical ammonia and other fluids. The Stokes-Einstein (S-E) relationship:

$$D = kT/6\pi r \eta \quad (7)$$

(where k is Boltzmann's constant, r the radius of the diffusing particle, and η the viscosity of the medium) is based on the model of a macroscopic sphere moving in an incompressible, continuous fluid. The molecules chosen for this study do not closely approach being spheres and the electrolyte is not continuous, but composed of ions and molecules roughly the same size as

the diffusing particles. Nonetheless, S-E has frequently been invoked for such liquids, and occasionally for supercritical media.^{1,24} The values of D in Table 2 are in qualitative agreement with such a model; that is, the larger molecules have smaller diffusion coefficients. Fig. 6 shows plots of D vs. T from 25° C to 150 °C for the neutral aza-aromatics and NB. The points are correlated by a line which represents the S-E relationship based on the experimentally determined value of r at 25° C. The data adhere reasonably well to the theoretical model, except in the case of PYR, where a positive deviation is observed. This deviation may be caused by the close proximity of the PYR wave to the cathodic background process at elevated temperature and probably does not represent a real deviation from S-E behavior. The overall agreement between theory and experiment suggests that the hydrodynamic assumptions inherent in S-E apply to near-critical and supercritical ammonia. Moreover, the basic fluid structure of ammonia, and the solvation sphere of the particles do not change radically with increasing temperature. Similar results were found in previous studies in supercritical water.^{1,24}

The energy of activation for diffusion (E_a) can be obtained from a plot of $\ln D$ vs. $1/T$ (Fig. 7) according to the equation:

$$D = D^* \exp -(E_A/RT) \quad (8)$$

A deviation from linearity of these plots would imply a marked structural change of the solvated species.²⁵ No evidence of such behavior is present in Fig. 7; this supports the earlier conclusion that the nature of diffusion and solvation in the SCF is similar to that of room temperature solutions. Table 2 lists numerical values for E_A derived from Fig. 7. These values are in accord with those found in previous investigations for diffusion in

aqueous media.^{1,26}

Solvated Electrons. Solvated electrons (e_s^-) have been prepared in a variety of solvents such as liquid ammonia, dimethyl sulfoxide, water, and propylene carbonate.²⁷ Electrons may exist in quasi-free and localized states, as well as in the stabilized solvated state,^{27h} but in which of these modes they are found in a particular setting has been the subject of much discussion. Recently, electrons have been injected into supercritical water and ammonia by photolysis and pulse radiolysis.²⁸ These investigations have been primarily aimed at the determination of the state of the electrons as a function of solvent density and time, but Krebs²⁹ has suggested that information from such experiments could also serve as a useful probe of the structure of supercritical ammonia.

In an earlier report on electrochemistry in supercritical ammonia², we showed the first evidence of electrogeneration of e_s^- in a SCF, but were unable to observe a current from reoxidation at scan rates up to 100 V/s. We interpreted this result as a fast reaction between e_s^- and NH_3



and concluded that the e_s^- half-life ($t_{1/2}$) was too short to be measured by voltammetric techniques at usual scan rates. In scrupulously clean metal-ammonia solutions, and in the absence of any catalyst, eq. 9 is quite slow; at $-70^\circ C$, $t_{1/2}$ ca. 1 year; at $25^\circ C$, $t_{1/2}$ ca. 300 hours.^{27e} The concentration of an electrochemically generated solution of e_s^- in 0.1 M KI decreased by only 3-7% in 3 h at $-55^\circ C$ ^{27a}; however, eq. 9 could become much more rapid in the SCF.

The lifetime of e_s^- formed by photoinjection into pure supercritical ammonia (containing no added electrolyte) has been reported to be around 5

μs .^{28h} Schindewolf et al.,³⁰ chemically generated long-lived solutions of e_s^- in supercritical ammonia by forcing the equilibrium of eq. 10 to the right, but this situation is not analogous to the electrochemical experiment, where there is no excess of H_2 or NH_2^- .



Fig. 8 shows new voltammetric data obtained for the electrochemical generation of e_s^- in supercritical ammonia. The most noticeable features of this voltammetry, as compared to the previous experiments,² are: the absence of a prewave just positive of the onset of e_s^- at temperatures above 25°C , and a wave near 0 V at 150°C , which corresponds to the reoxidation of e_s^- . We now know the prewave to be due to the presence of trace water,³¹ which might account for our initial failure to observe a current for the oxidation of e_s^- . Pure water is known to react very quickly with e_s^- ($t_{1/2}$ ca. $100\ \mu\text{s}$)^{32a}:



However, Schindewolf^{32b} reported that the lifetime of e_s^- increased exponentially with increasing mole fraction of ammonia; for a 20% solution of water in ammonia, $t_{1/2}$ for e_s^- is around 100 s. Therefore, in our system, reaction of e_s^- with water is probably very slow even at elevated temperature because of the extremely low level of water present. A second explanation involves the presence of electron traps generated in the working solution at the counter electrode. For example, H^+ in the form NH_4^+ , reacts rapidly with e_s^- ($k = 4 \times 10^{-6}\ \text{M}^{-1}\ \text{s}^{-1}$ at -34°C)³³:



At present we are unable to determine the rate-determining step for the disappearance of e_s^- in supercritical ammonia; however, from the sweep rate at which reoxidation of e_s^- is detectable at 150° C, Fig. 8c, we estimate $t_{1/2}$ of electrochemically generated e_s^- in supercritical ammonia containing electrolyte to be at least 5 ms. This figure represents a lower limit, because a trace of water or other reactive impurity may be present, which affects the stability of e_s^- .

Thermodynamics. To relate potentials to one another it is necessary to establish an arbitrary standard electrode. The normal hydrogen electrode (NHE) has been selected as the standard reference electrode, and the half-reaction which this electrode represents:



is assigned a potential of zero volts at all temperatures in all solvents. The difficulty of building a NHE for use in a SCF has already been discussed. This prevents assignment of half-reaction potentials on the NHE scale, but does not hinder thermodynamic measurement of the free energy change of chemical reactions ΔG_{rxn} , or ΔS_{rxn} and ΔH_{rxn} , from the temperature coefficient of the potential. The derivative of potential with temperature at constant pressure yields the entropy change (ΔS) of a cell reaction:

$$\Delta S = nF(dE/dT)_p \quad (14)$$

where n is the number of electrons involved in the reaction, F the Faraday, and E the potential of the reversible reaction. If all species involved in the reaction are in their standard states, and if the diffusion and activity coefficients of the oxidized and reduced species taking part in the reaction are the same, then eq. 14 can be rewritten:

$$\Delta S^\circ = nF(dE_{1/2}/dT)_p \quad (15)$$

where $E_{1/2}$ is the polarographic half-wave potential which is available from cyclic voltammetry. $E_{1/2}$ was obtained from the average of $E_{p,c}$ and $E_{p,a}$ so that deviations because of iR drop and quasi-reversibility are minimized.

In Fig. 9 the values of $E_{1/2}$ are plotted against temperature for the first reductions of PYR, QUIN, PHEN, and NB; and the second reductions of QUIN and PHEN. The slopes of the linear portions of the resulting lines, $dE_{1/2}/dT$, are tabulated in Table 2, along with the calculated value of ΔS°_{rxn} . For convenience many of the values of $dE_{1/2}/dT$ were not acquired at constant pressure; however, those that were demonstrated the pressure effect on ΔS to be negligible for these reactions over the pressure range 10 to 350 bar. The entropy values we report are for the reaction:



which is comprised of the two half-reactions:



where e_m^- is the electron in the metal electrode. The measured reaction entropy of eq. 16 arises primarily from restructuring of the solvent around the radical anion and the solvation entropy of e_s^- , eq. 18. The Born equation³⁴ can be used to estimate the difference in solvation entropy for a neutral species and its ion, essentially the reaction entropy of eq. 17.

$$\Delta S^\circ = z^2 e^2 N (\partial \epsilon / \partial T) / 8\pi \epsilon_0 r \epsilon^2 \quad (19)$$

where: z is the charge on the ion, ϵ_0 the permittivity of free space, e the charge on the electron, r the radius of the ion, N Avogadro's number, and ϵ the dielectric constant of the medium at the temperature of interest. If the radius of the ion is taken as the hydrodynamic radius (average $r = 1.7 \text{ \AA}$) derived from the Stokes-Einstein relationship, eq. 7, and $\partial \epsilon / \partial T$ is taken from the literature,³⁵ then ΔS° at 25° C ranges from -140 to $-190 \text{ J-K}^{-1}\text{-mol}^{-1}$ for the solvation of the ions studied. These theoretical values can be compared to the experimental results, if the solvation entropy of e_s^- (eq. 18) is accounted for; that is,

$$\Delta S^\circ_{\text{eq 16}} + \Delta S^\circ_{\text{eq 18}} = \Delta S^\circ_{\text{eq 17}}$$

where $\Delta S^\circ_{\text{eq 18}} \sim 48 \text{ J-K}^{-1}\text{-mol}^{-1}$.³⁶ The average experimental value of $\Delta S^\circ_{\text{eq 17}}$ is $-172 \text{ J-K}^{-1}\text{-mol}^{-1}$, in good agreement with the average theoretical value, $-165 \text{ J-K}^{-1}\text{-mol}^{-1}$.

Few entropy measurements for the reduction of aromatics in aprotic solvents have been made previously. Schindewolf³⁷ measured ΔS_{rxn} for the reduction of 9 aromatics in liquid ammonia by homogeneous reaction of the neutral species with e_s^- between -75° C and -35° C . ΔS_{rxn} was found to average $-215 \pm 25 \text{ J-K}^{-1}\text{-mol}^{-1}$, in good agreement with the average value of

this study $\overline{\Delta S}_{\text{rxn}} = -220 \pm 40 \text{ J-K}^{-1}\text{-mol}^{-1}$. Saveant³⁸ measured the relative difference in entropy between successive electron transfers for a series of polynitro compounds in aprotic solvents, but did not report the change in entropy (ΔS) for individual reductions.

An additional interesting feature of Fig. 9 is that the $E_{1/2}$ vs. T lines are straight, except in one case, indicating no temperature dependence on the entropy even in the SCF. This suggests that the change in solvent organization between the $R/R^{\cdot-}$ and $R^{\cdot-}/R^{2-}$ couples in liquid and supercritical ammonia is generally quite similar; however, the aberrant behavior of the second reduction of PHEN may indicate a change in the nature of the solvation upon reduction of $\text{PHEN}^{\cdot-}$ at low and high temperature.

The thermodynamic parameters $\Delta G^{\circ}_{\text{rxn}}$, $\Delta S^{\circ}_{\text{rxn}}$, and $\Delta H^{\circ}_{\text{rxn}}$, for the cross reactions between any of the neutral, anionic, or dianionic species investigated can be calculated from the data in Table 2. For example, the equilibrium constant, K , for the disproportionation of $\text{PHEN}^{\cdot-}$:



can be calculated at any temperature since:

$$\Delta E_{\text{p,c}} = RT/nF \ln K \quad (21)$$

where $\Delta E_{\text{p,c}}$ is the difference in potential for the reductions of PHEN and $\text{PHEN}^{\cdot-}$. For eq. 20 at 25° C and 150° C, $K = 9.2 \times 10^{-13}$ and 2.1×10^{-11} , respectively.

CONCLUSIONS

We have demonstrated that normal electrochemical techniques are applicable to supercritical ammonia solutions, although the implementation

can be somewhat challenging. Aside from an increase in solution resistance, the results of cyclic voltammetric and chronoamperometric experiments indicate that electrochemical processes that are reversible in liquid ammonia at low temperature are reversible, or nearly reversible, in the SCF. The behavior of PHEN in the SCF was found to be analogous to that at -40°C indicating that the intrinsic nature of ammonia, rather than lowered temperature, is responsible for the stability of the dianion. The chemistry of following homogeneous reactions of NB in the SCF were interpreted in terms of results obtained at low temperature, thereby demonstrating the functional similarity of liquid and supercritical ammonia. Further work on the kinetics of coupled homogeneous reactions and heterogeneous electron transfer is anticipated.

The standard potentials of all redox couples studied became more negative with an increase in temperature, indicating increased solvation (and ion-pairing) upon reduction. Since this change was generally linear throughout the temperature range studied, the nature of solvation between liquid ammonia and the SCF is not very different. Overall, the experimental results show that free energies of reaction, and other thermodynamically meaningful parameters are accessible from electrochemical experiments in the SCF.

Diffusion coefficients, determined for temperatures up to 150°C , demonstrated that the hydrodynamic Stokes-Einstein relationship, and the theory of activated diffusion, can be applied to the SCF. Such agreement suggests that many of the concepts that underlie solvation of normal liquids also apply to the SCF. Thus electrochemistry is a valuable probe of species in the supercritical phase and is quite similar to that found at lower temperatures. It should be possible to take advantage of the tunable parameters of the SCF, such as the solvating power, to perform new types of

syntheses and separations. Electrochemistry should also be a valuable tool for understanding the structure of the supercritical state.

ACKNOWLEDGMENT

The support of this research by the Office of Naval Research and the Separations Research Program at the University of Texas is gratefully acknowledged. We also thank Ramy Farid for his assistance during initial experiments.

Table 1. Properties of Ammonia.

Temperature Domain	Low	Room	Critical	Working
T (° C)	- 40	25	133	150
P (bar)	0.7	9.5	112	285
Density (g/cm ³)	0.69	0.60	0.24	0.43
Static Dielectric Constant	23	17	3-4	8
Viscosity (cP)	0.28	0.15	0.024	0.054

Table 2. Summary of Voltammetric and Chronoamperometric Parameters for Reduction of Organics in Ammonia.

COMPOUND	Pyrazine		Guinoxaline		Phenazine		Nitrobenzene	
	1	2	1	2	1	2	1	2
REDUCTION								
TEMPERATURE (°C)	25	150	25	150	25	150	25	150
$i_{p,a} / i_{p,c}$ ^(a)	1.01	0.99	1.01	1.01	0.99	0.98	1.04	1.12
$i_{p,c} / v^{1/2} C$ ^(a) ($A s^{1/2} cm^3$) / (V mol)	17.9	28.8	17.9	29.0	18.3	28.6	16.2	23.4
$E_{p,c}$ (V vs. e_s)	0.63	0.32	1.10	0.81	1.55	1.25	0.84	0.62
ΔE_p (mV) ^(a)	94	150	78	128	76	116	78	116
Diffusion Coefficient $\times 10^4$ (cm^2/s)	1.0	5.1	0.77	3.2	0.75	3.0	(c)	(c)
Activation Energy For Diffusion $\times 10^{-4}$ (J/mol · K)	1.3		1.2		1.1		(c)	
$dE_{1/2} / dT$ (mV / °C)	-2.5		-2.3		-2.5		-2.2	
$\Delta S_{rxn}^\circ \times 10^{-2}$ (J/mol · K)	-2.4		-2.2		-2.4		-2.1	

(a) see reference 9. (b) Vs. Ag-QRE. (c) Data unavailable

REFERENCES

- ¹ (a) McDonald, A.C.; Fan, F. F.; Bard, A.J. *J. Phys. Chem.*, **1986**, *90*, 196-202. (b) Flarsheim, W.M.; Tsou, Y.; Trachtenberg, I; Johnston, K.P.; Bard, A.J. *J. Phys. Chem.*, **1986**, *90*, 196-202. (b) Flarsheim, W.M.; Tsou, Y.; Trachtenberg, I; Johnston, K.P.; Bard, A.J. *J. Phys. Chem.*, In Press.
- ² Crooks, R.M.; Fan, F.F.; Bard, A.J. *J. Am. Chem. Soc.*, **1984**, *106*, 6851-6852.
- ³ (a) Franck, E.U. "High Pressure Chemistry", Kelm, H., Ed.; D. Reidel: Boston, 1978; p 243. (b) Nicholls, D. "Inorganic Chemistry in Liquid Ammonia"; Elsevier: Boston, 1979; pp 9-10. (c) Buback, M.; Harder, W.D. *Ber. Bunsenges. Phys. Chem.*, **1977**, *81*, 603-614.
- ⁴ Varagaftik, N.B., Ed. "Handbook of Physical Properties of Liquids and Gases", 2nd ed.; Hemisphere: Washington, 1975, pp 464-476.
- ⁵ (a) Gronier, W.S.; Thodos, G. *J. Chem. Eng. Data*, **1979**, *6*, 240-244. (b) Carmichael, L.T.; Reamer, H.H.; Sage, B.H. *J. Chem. Eng. Data*, **1963**, *8*, 400-404.
- ⁶ (a) Franck, E.U.; Deul, R. *Faraday Discuss. Chem. Soc.*, **1979**, 191-198. (b) Cobble, J.W.; Murray, R. C., Jr. *Faraday Discuss. Chem. Soc.*, **1977**, 144-149. (c) Hills, G.J.; Ovenden, P.J. "Adv. Electrochem. Electrochem. Eng.", Delahay, P.; Tobias, C., Ed.; Wiley: New York, 1965; pp 185-247. (d) Franck, E.U. *Ber. Bunsenges. Phys. Chem.*, **1984**, *88*, 820-825. (e) MacDonald, D.D. "Modern Aspects of Electrochemistry, Vol. 11", Conway, B.E.; Bockris, J. O'M., Ed.; Plenum: New York, 1975, pp 141-197. (f) Kobe, K. A.; Emerson, L., Jr. *Chem. Rev.*, **1953**, *52*, 121-132. (g) Franck, E.U. "Fourth Proc. Int. Conf. High Pressure,

Kyoto 1974", Osugi, J., Ed.; Physio-Chemical Soc. Japan, Kyoto, 1975, pp 26-34. h) Franck, E.U. "Organic Liquids: Structure, Dynamics and Chemical Properties", Buckingham, A.D.; Lippert, E.; Bratos, S., Ed.; Wiley: Chichester, 1978, pp 181-194.

⁷ (a) Teherani, T.; Bard, A.J. *Acta Chem. Scand. Ser. B*, **1983**, *37*, 413-422. (b) Smith, W.H.; Bard, A.J. *J. Am. Chem. Soc.*, **1975**, *97*, 5203-5210. (c) Demortier, A.; Bard, A.J. *J. Am. Chem. Soc.*, **1973**, *95*, 3495-3500. (d) Uribe, F.; Sharp, P.R.; Bard, A.J. *J. Electroanal. Chem.*, **1983**, *152*, 173-182. (e) Teherani, T.H.; Peer, W.J.; Lagowski, J.J.; Bard, A.J. *J. Am. Chem. Soc.*, **1978**, *100*, 7768-7770. (f) Werner, M.; Schindewolf, U. *Ber. Bunsenges. Phys. Chem.*, **1980**, *84*, 547-550. (g) Saveant, J.M.; Thiebault, A. *J. Electroanal. Chem.*, **1978**, *89*, 335-346. (h) Herlem, M.; Minet, J.J.; Thiebault, A. *J. Electroanal. Chem.*, **1971**, *30*, 203-217. (i) Laitinen, H.A.; Shoemaker, C.E. *J. Am. Chem. Soc.*, **1950**, *72*, 663-665.

⁸ (a) Bridgman, P. "The Physics of High Pressure"; G. Bell and Sons: London, 1949. (b) Hamann, S.D. "Physico-Chemical Effects of Pressure", Academic Press: New York, 1957; pp 7-30. (c) Rößling, G.L.; Franck, E. U. *Ber. Bunsenges. Phys. Chem.*, **1983**, *87*, 882-890. (d) Bett, K.E.; Newitt, D.M. "Chemical Engineering Practice, Vol. 5", Cremer, H.W.; Davies, T., Eds.; Butterworths: London, 1958, pp 196-298. (e) Downs, J.L.; Payne, R.T. *Rev. Sci. Instrum.*, **1969**, *40*, 1278-1280.

⁹ Bard, A.J.; Faulkner, L.R. "Electrochemical Methods", Wiley: New York, 1980, p 142-145 and 213-235.

- 10 Silvestri, G.; Gambino, S.; Gilardo, G.; Cuccia', C.; Guarino', E. *Angew. Chem. Int. Ed. Engl.*, 1981, 20, 101-102.
- 11 Jones, D. de G.; Masterson, H.G. "Advances in Corrosion Science and Technology, Vol. 1", Fontana, M.G; Staehle, R.W., Ed.; Plenum: New York, 1970, pp1-49, and references therein.
- 12 MacDonald, D.D *Corrosion* ,1978,34,75-84, and references therein.
- 13 Hills, G. J. "Reference Electrodes: Theory and Practice", Ives, D.J.G; Janz, G.J., Eds.; Academic Press: New York, 1961, pp 433-460.
- 14 Laitinen, H.A.; Nyman, C.J. *J. Am. Chem. Soc.*, 1948, 70,3002-3008.
- 15 Schindewolf, U.; Werner, M. *J. Phys. Chem.*, 1980, 84, 1123-1127.
- 16 Schmidt, V.H.; Meinert, H. *Z. Anorg. Allg. Chem.*, 1958, 295,156.
- 17 Baumgartel, H.; Retzlav "Encyclopedia of Electrochemistry of the Elements", Bard, A.J.; Lund, H., Eds.; Marcel Dekker: New York, 1984; pp168-317.
- 18 Reference 9, p. 218-240.
- 19 Techniques generally used to discern information from the voltammetry of multistep charge transfers were ineffective on account of convection (Reference 9, p. 232-236.); therefore the semiempirical method suggested by Nicholson was applied. (Nicholson, R.S. *Anal. Chem.*, 1966, 38, 1406).

- 20 (a) Birchall, T.; Jolly, W.L. *J. Am. Chem. Soc.*, **1965**, *87*, 3007-3008. (b) Cuthrell, R.E.; Fohn, E.C.; Lagowski, J.J.; *Inorg. Chem.*, **1966**, *5*, 111-114. (c) Takemoto, J.H.; Lagowski, J.J.; *Inorg. Nucl. Chem. Letters*, **1970**, *6*, 315-319.
- 21 (a) Robertson, R.E.; Scott, J.M.W.; Golding, P.D. *J. Am. Chem. Soc.*, **1981**, *103*, 5923-5925. (b) Noyes, A.A.; Kato, Y.; Sosmun, R.B. *Z. Phys. Chem.*, **1910**, *73*, 1-24.
- 22 Jolly, W.L. *Adv. Chem. Ser.* **1965**, *50*, 27.
- 23 Schindewolf, U.; Schwab, H. *J. Am. Chem. Soc.*, **1981**, *85*, 2707-2708.
- 24 Lamb, W.J.; Hoffman, G.A.; Jonas, J. *J. Chem. Phys.*, **1981**, *74*, 6875-6880.
- 25 Bockris, J.O'M.; Reddy, A.K.N. "Modern Electrochemistry", Plenum: New York, 1977; p544-547.
- 26 Mallouk, T.E.; Cammarata, V.; Crayston, J.A.; Wrighton, M.S. *J. Phys. Chem.*, In Press.
- 27 For previous studies of e_S^- in ammonia see; (a) Teherani, T.; Itaya, K.; Bard, A.J.; *Nouv. J. Chim.*, **1978**, *2*, 481-487. (b) Schindewolf, U. *Angew. Chem., Int. Ed. Engl.*, **1968**, *7*, 190-202. (c) Bard, A.J.; Itaya, K.; Malpas, R.E.; Teherani, T. *J. Phys. Chem.*, **1980**, *84*, 1262-1266. (d) Uribe, F.A.; Sawada, T.; Bard, A.J. *Chem. Phys. Letters*, **1983**, *97*, 243-246. (e) Jolly, W.L. "Metal-Ammonia Solutions", Lagowski, J.J.; Sienko, M.J., Eds.; Butterworths: London, 1970; pp

168-181. (f) Lepourte, G.; Jortner, J. *J. Phys. Chem.*, **1972**, *76*, 683-687. (g) Postl, D.; Schindewolf, U. *Ber Bunsenges. Phys. Chem.*, **1971**, *75*, 662-665. (h) Krohn, C.E.; Antoniewicz, J.C.; Thompson, J.C. *Surf. Sci.*, **1980**, *101*, 241.

28 (a) Jortner, J.; Gaathon, A. *Can. J. Chem.*, **1977**, *55*, 1801-1819. (b) Krebs, P.; Wanschik, M. *J. Phys. Chem.*, **1980**, *84*, 1155-1160. (c) Thompson, J.C.; Even, U.; Blanks, D.K. *J. Phys. Chem.*, **1984**, *88*, 3709-3711. (d) Krebs, P.; Bukowski, K.; Giraud, V.; Heintze, M. *Ber Bunsenges. Phys. Chem.*, **1982**, *86*, 879-887. (e) Olinger, R.; Hahne, S.; Schindewolf, U. *Ber. Bunsenges. Phys. Chem.*, **1972**, *76*, 349-350. (f) Giraud, V.; Krebs, P. *Chem. Phys. Letters*, **1982**, *86*, 85-90. (g) Krebs, P. *J. Phys. Chem.*, **1984**, *88*, 3702-3709. (H) Krebs, P.; Heintze, M. *J. Chem. Phys.*, **1982**, *76*, 5484-5492.

29 Krebs, P. *Chem. Phys. Letters*, **1980**, *70*, 465-468.

30 Schindewolf, U.; Vogelsgesang, R.; Bøddeker, K.W. *Angew. Chem. Int. Ed. Eng.*, **1967**, *6*, 1076-1077.

31 (a) Herlem, M. *Bull. Soc. Chim. Fr.*, **1967**, 1687. (b) Herlem, M.; Minet, J.; Thiebault, A. *J. Electroanal. Chem.*, **1971**, *30*, 203.

32 (a) Gould, R.F., Ed. "Advances in Chemistry, No. 50", American Chemical Society: Washington, D.C., 1965. (b) Schindewolf, U. "Metal-Ammonia Solutions", Lagowski, J.J.; Sienko, M.J., Eds.; Butterworths: London, 1970; pp 199-218.

33 Schindewolf, U. *J. Phys. Chem.*, **1984**, *88*, 3820-3826.

34 Lewis, G.N.; Randall, M. "Thermodynamics", 2nd ed., McGraw-Hill: New York, 1961, p 523.

35 Reference 4a, p. 243.

36 Lepoutre, G.; Jortner, J. *J. Phys. Chem.*, 1972, 76, 683-687.

37 Gross, W.; Schindewolf, U. *Ber. Bunsenges. Phys. Chem.*, 1981, 85, 112-116.

38 (a) Ammar, F.; Savéant, J.M. *J. Electroanal. Chem.*, 1973, 47, 115-125. (b) Andrieux, C.P.; Savéant, J.M. *J. Electroanal. Chem.*, 1974, 57, 27-33.

FIGURE CAPTIONS

Figure 1. (a) Schematic diagram of high pressure/high temperature apparatus. V1-6, High pressure valves; S1, Sample solution; S2, Solvent; R, Rinse solution; VL, Vacuum line connection; BO, Blowout Disk; VT, Vent; G1-2, Pressure gages; PG, Pressure generator; S/B, Separator with bellows; T, Temperature indicator; I/V, Electrochemical measurement system; CV, Insulated containment vessel; EC, Electrochemical cell; TC, Temperature controller. (b) Top: Electrode construction details. Middle: Electrochemical cell. Bottom: Detailed view of internal electrode configuration.

Figure 2. Plot of cell resistance (R) vs. temperature (T) in near critical and supercritical ammonia. Resistance measurements made by recording the feedback voltage required to minimize the cell time constant for a 40 mV, 1 kHz square wave applied to the working electrode. The distance between electrodes was around 0.5 cm. The data was for a constant mass of ammonia. Average electrolyte concentration: 0.15 M $\text{CF}_3\text{SO}_3\text{K}$.

Figure 3. Cyclic voltammetry in ammonia/ $\text{CF}_3\text{SO}_3\text{K}$ at a W working electrode (0.0083 cm^2). (a) supporting electrolyte only: Top, 0.20 M; Bottom, 0.14 M. (b) pyrazine: Top, 6.5 mM; Bottom, 4.6 mM. (c) quinoxaline: Top, 3.6 mM; Bottom, 2.6 mM. (d) phenazine: Top, 4.3 mM; Bottom, 3.2 mM. In all cases the top voltammogram was taken at 25°C and 9.5 bar and the bottom at 150°C and 285 bar (supercritical). The concentration varies because of differences in solvent density. Scan rate = 2 Vs^{-1} . Potentials are vs. the onset of e_s^- .

Figure 4. Cyclic voltammetry of nitrobenzene (NB) in ammonia/CF₃SO₃K. First reduction only: (a) 25°C, 9.5 bar, C_{NB}= 4.1 mM; (b) 150°C, 285 bar (supercritical), C_{NB}= 2.7 mM. First and second reduction in the presence of a trace of water: (c) 25°C, 9.5 bar, C_{NB}= 4.1 mM; (d) 150°C, 285 bar (supercritical), C_{NB}= 2.7 mM. Reduction in the presence of approximately 1:1 water / NB: (e) 25°C, 9.5 bar, C_{NB}= 5.33 mM; (f) 150°C, 285 bar (supercritical), C_{NB}= 3.51 mM. Scan rate = 1 Vs⁻¹. Potentials vs. e_S⁻.

Figure 5. Representative plots of charge (Q) vs. t^{1/2} derived from the integrated chronoamperometric response of aromatics in supercritical ammonia at a W electrode (0.0083 cm²): (a) 4.59 mM pyrazine, slope= 2.28 μC/ms^{1/2}; (b) 6.55 mM quinoxaline slope= 2.37 μC/ms^{1/2}; (c) 3.96 mM Phenazine, slope= 1.27 μC/ms^{1/2}; (d) 3.88 mM nitrobenzene, slope= 1.58 μC/ms^{1/2}. Conditions: T=150°C; P=285 bar; electrolyte, 0.14 M CF₃SO₃K. All concentrations corrected for changes in the density of ammonia. The diffusion coefficients reported in Table 2 represent the average of several independent experiments.

Figure 6. Dependence of the diffusion coefficient on temperature. The points represent experimental data, and the solid line represents the Stokes-Einstein fit based on the experimentally determined effective molecular radius at 25°C. (a) pyrazine, r=1.45 Å; (b) quinoxaline, r=1.89 Å; (c) phenazine, r=1.94 Å; (d) nitrobenzene, r=1.45 Å.

Figure 7. Plot of ln. D (Diffusion Coefficient) vs. 1/T.

Figure 8. Cyclic voltammetry of solvated electrons (e_s^-) in ammonia/ CF_3SO_3K . (a) $25^\circ C$, 9.5 bar, scan rate (v) = 1 Vs^{-1} ; (b) $100^\circ C$, 100 bar, $v=1 \text{ Vs}^{-1}$; (c) $150^\circ C$, 285 bar (supercritical), $v=10 \text{ Vs}^{-1}$; (d) $25^\circ C$ (after cooling from $150^\circ C$), 9.5 bar, $v=1 \text{ Vs}^{-1}$. Potentials vs. e_s^- .

Figure 9. Dependence of the polarographic half-wave potential ($E_{1/2}$) on temperature. (1st) and (2nd) refer to the first and second reductions as shown in eqs 2 and 3.

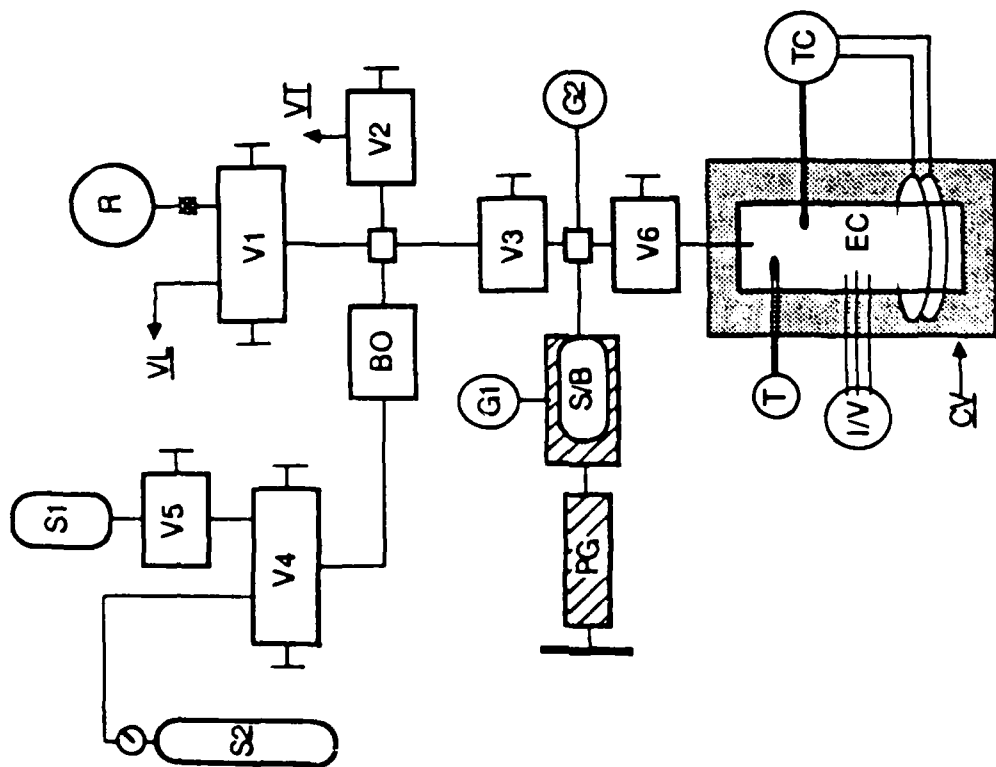
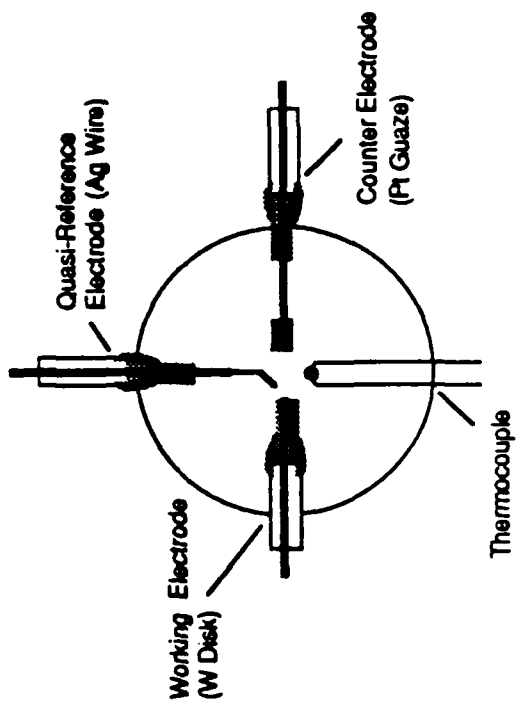
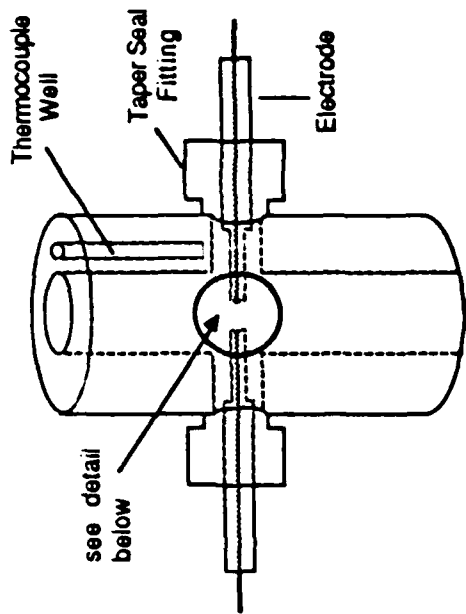
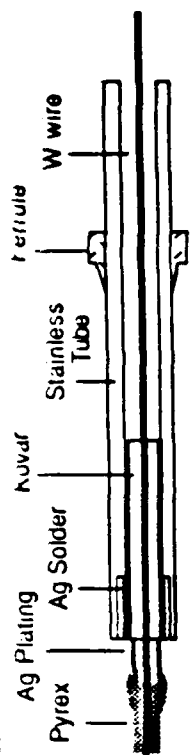

A

B

Figure 1

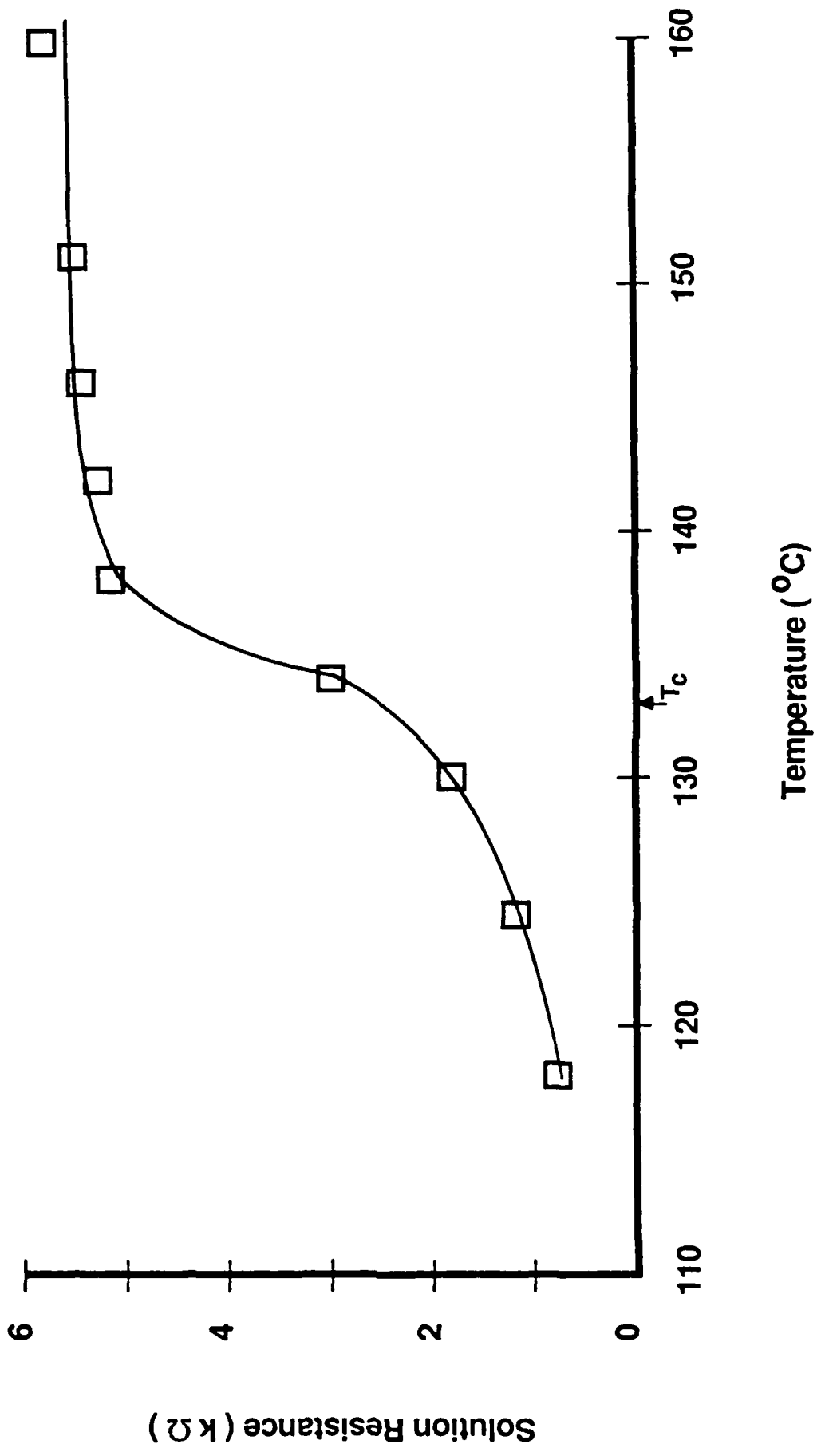
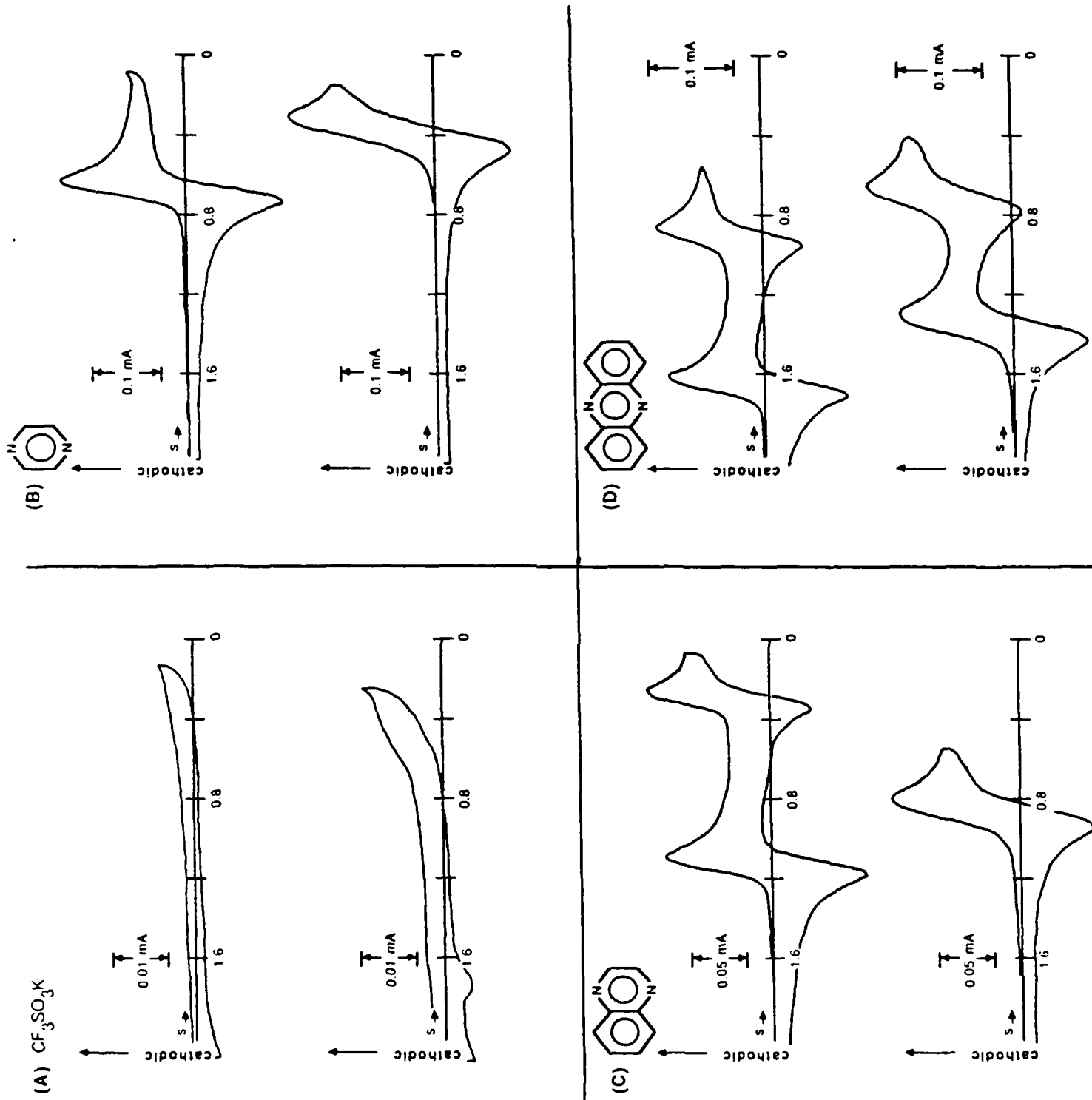

Figure 2

Figure 3



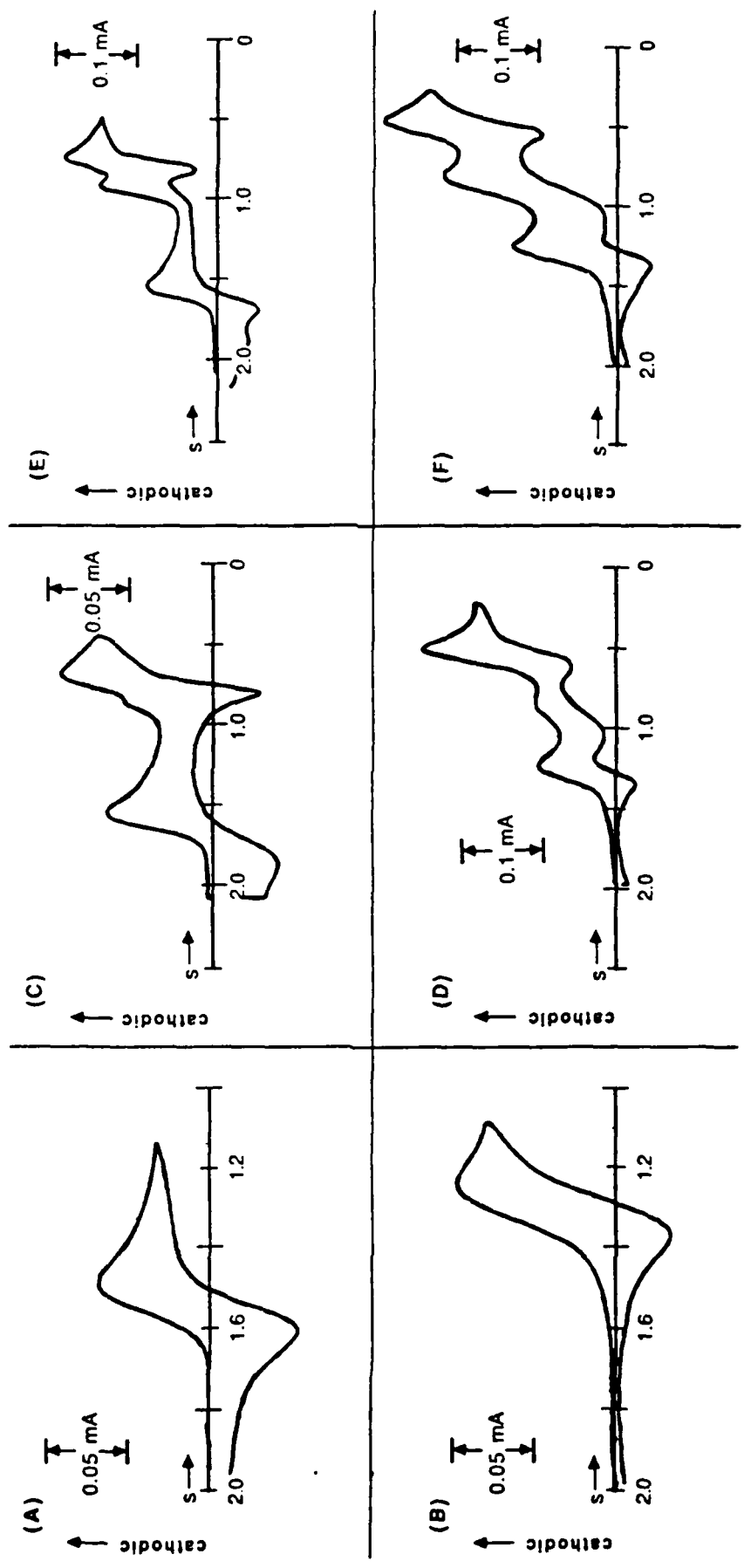

Figure 4

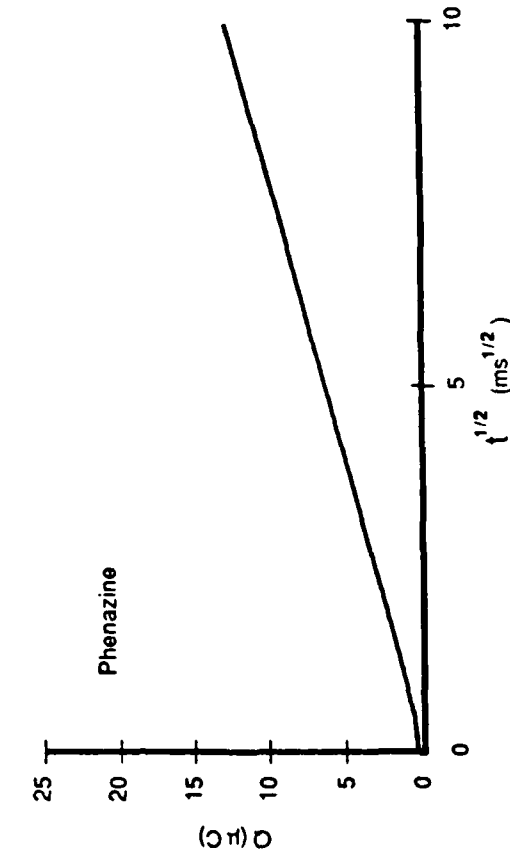
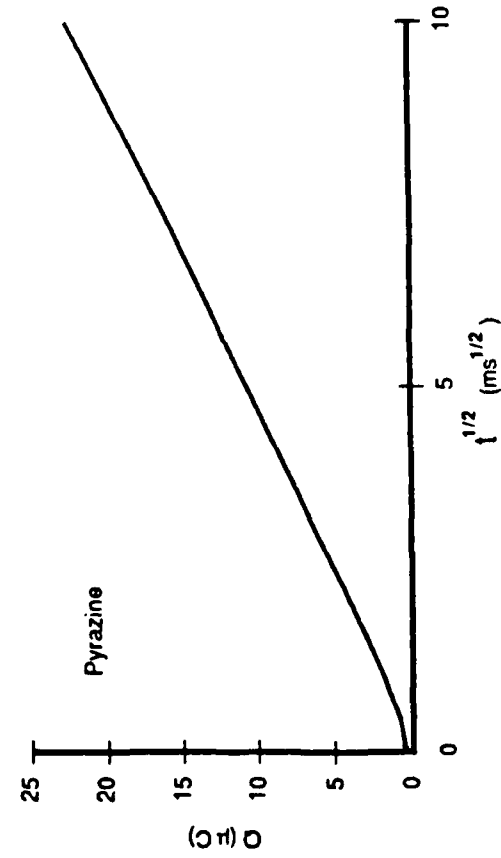
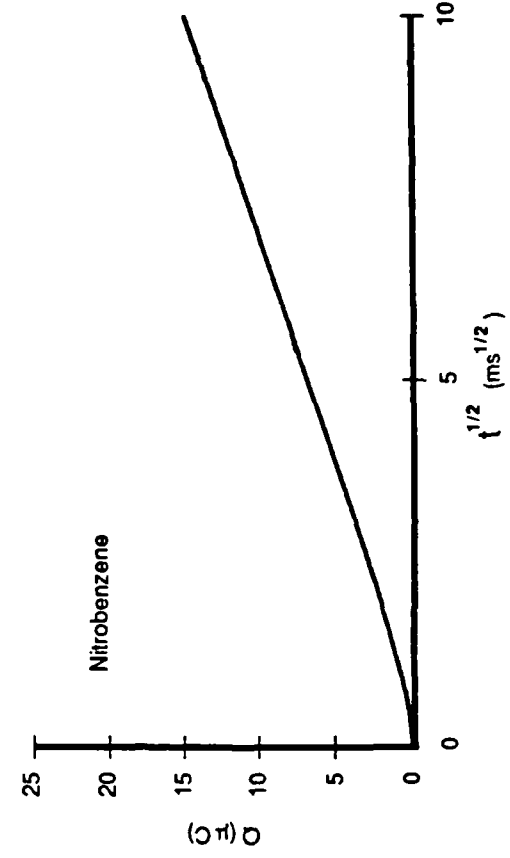
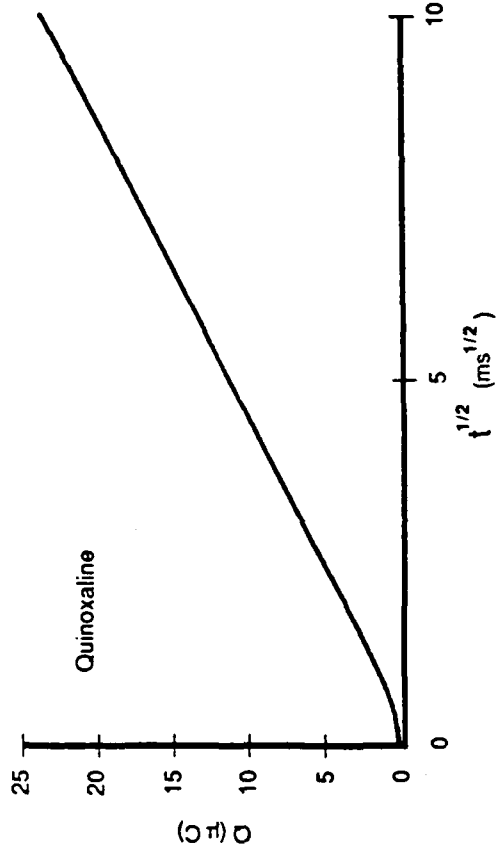

Figure 5

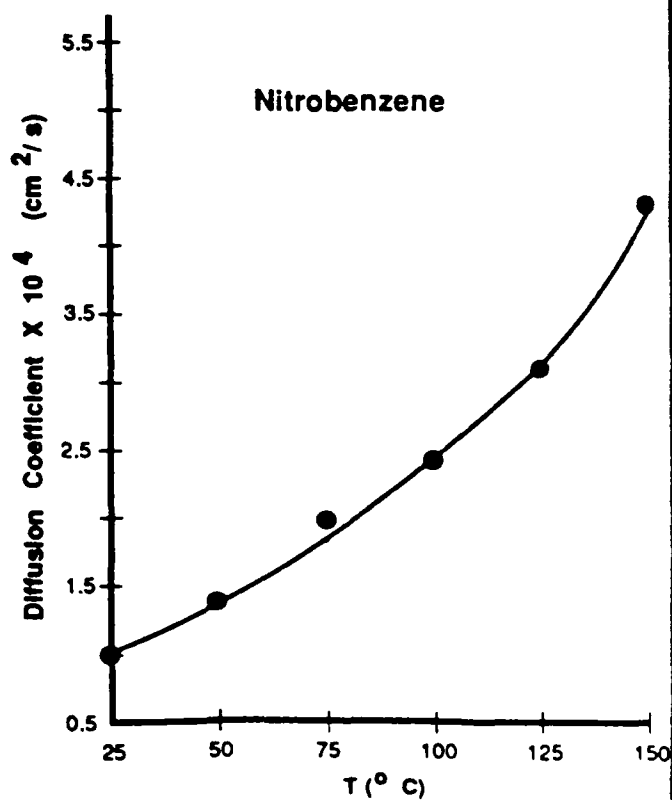
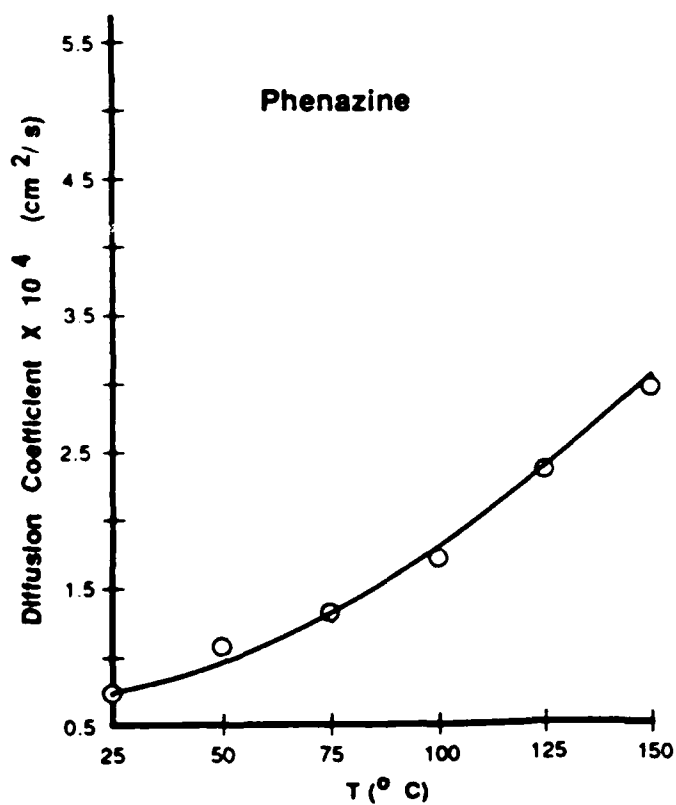
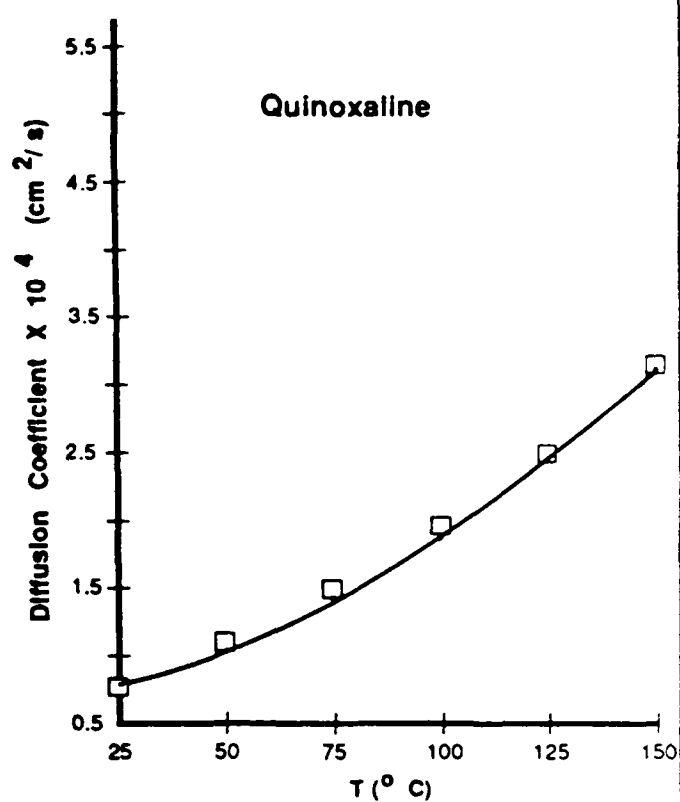
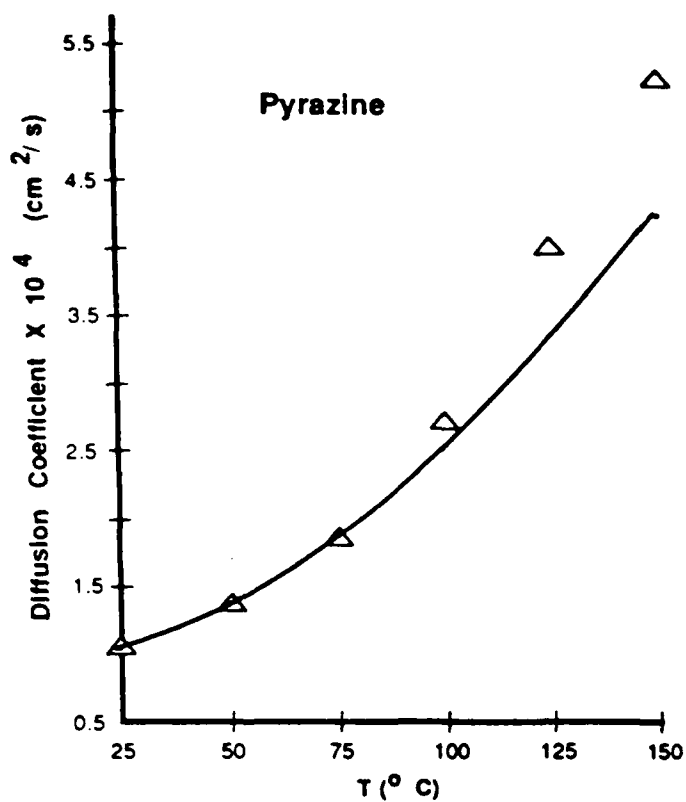

Figure 6

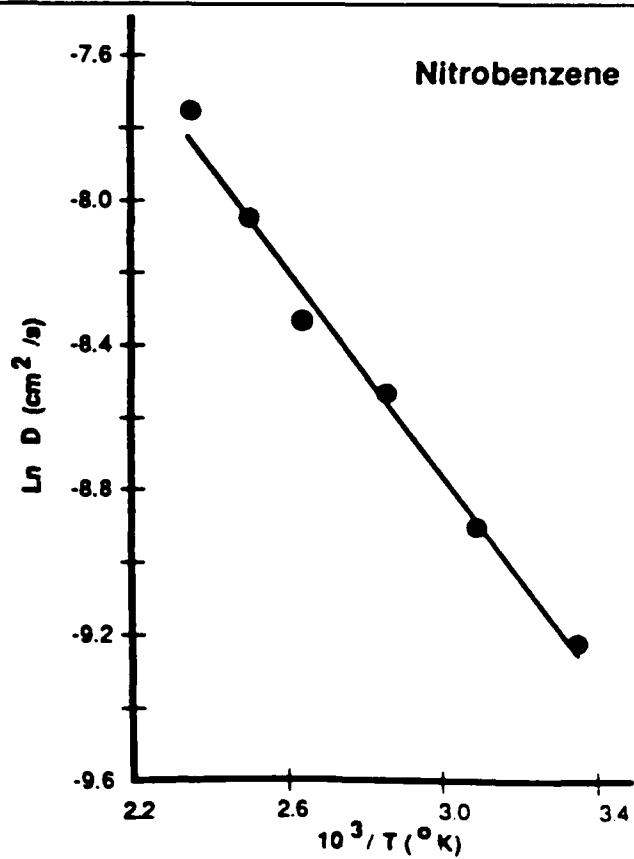
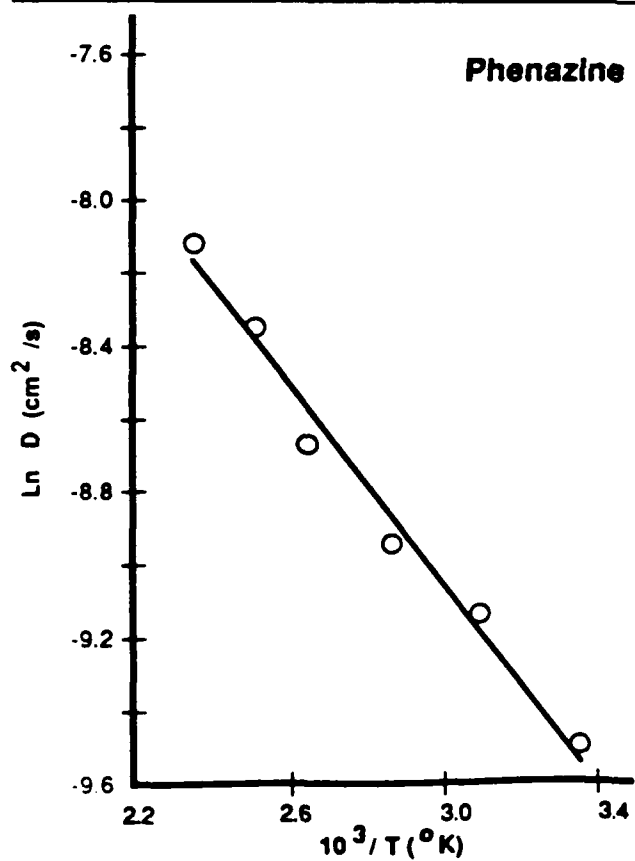
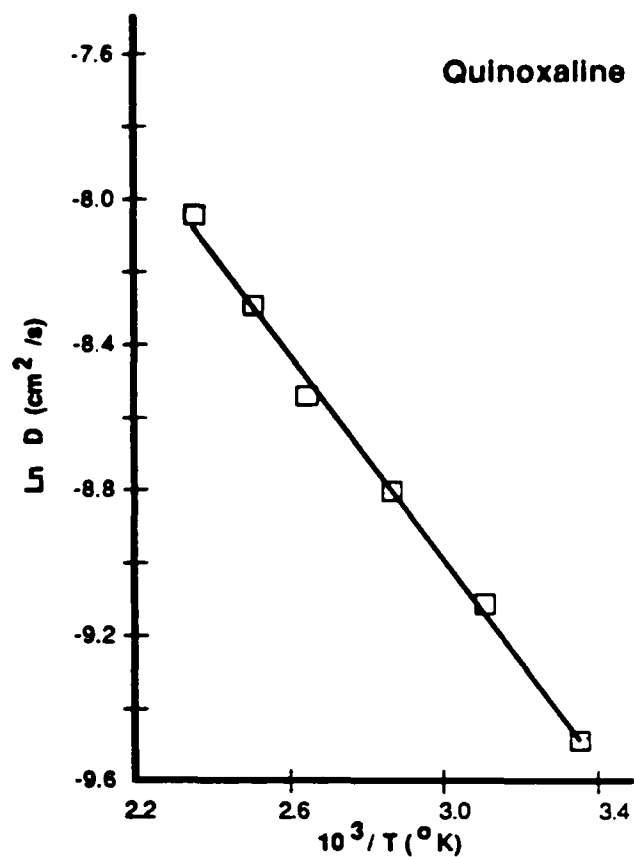
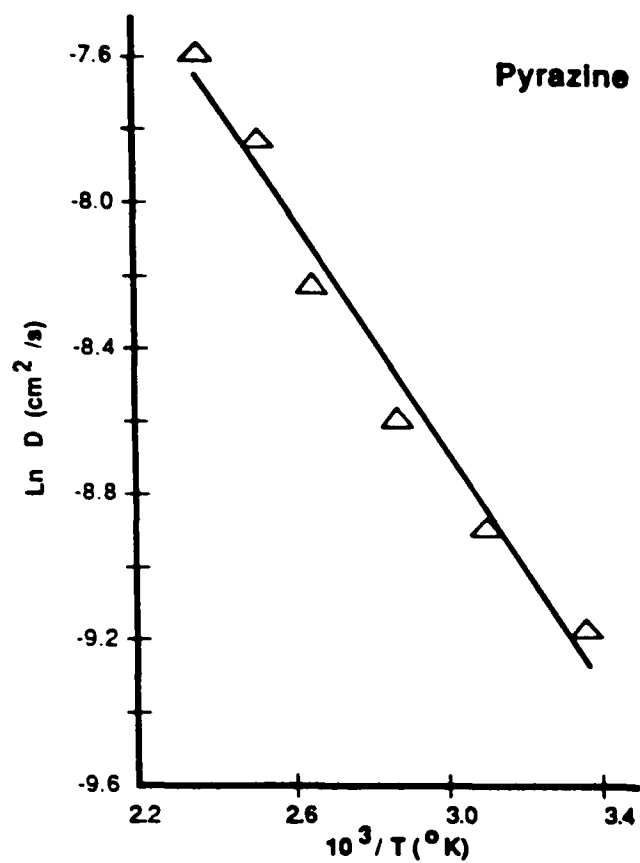

Figure 7

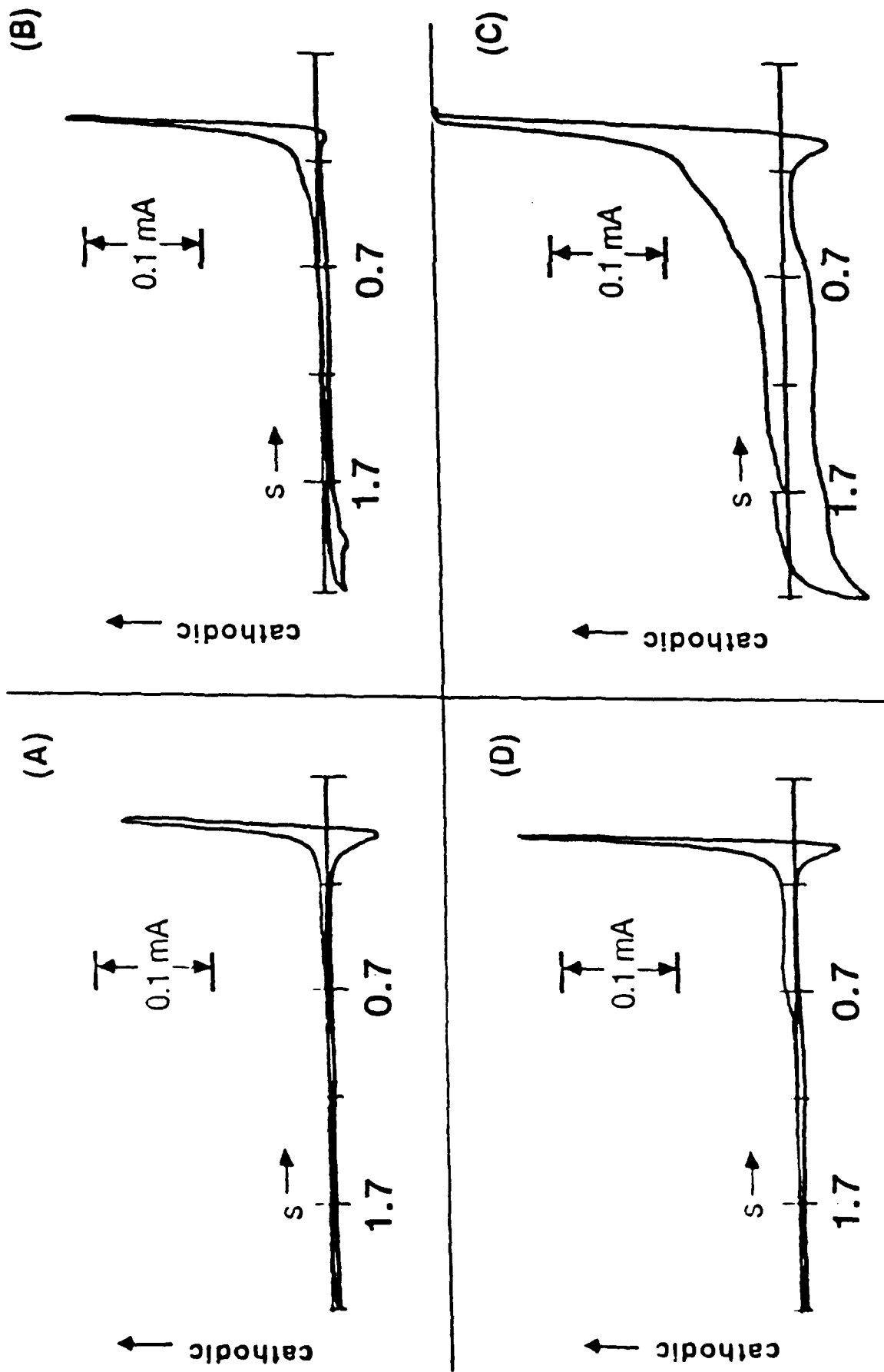

Figure 8

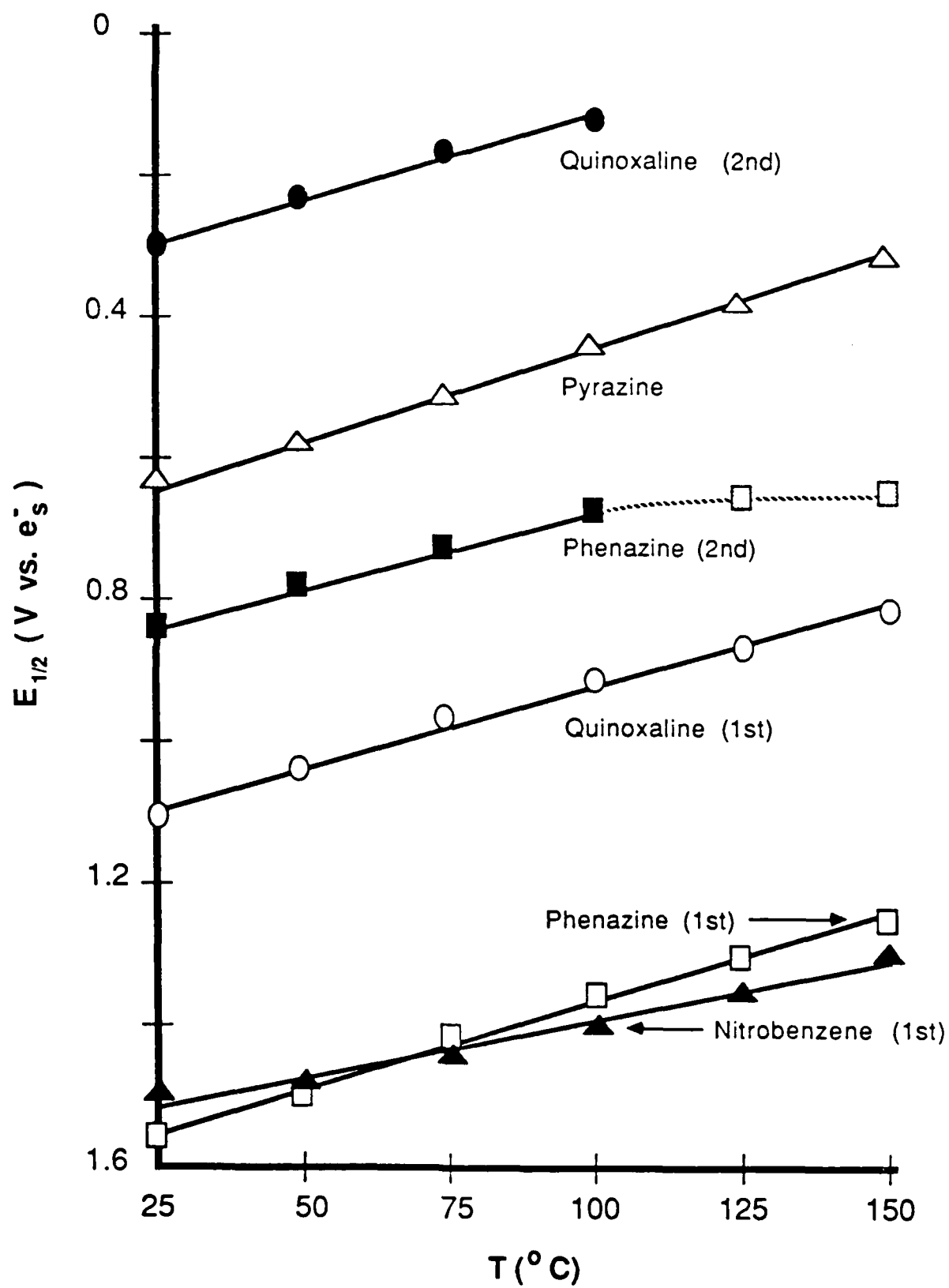

Figure 9

END

1-87

DTIC