

AD-R174 907

AN EVALUATION OF FLASHLIGHTS EXPOSED TO CONTINUOUS-WAVE 1/1
AND PULSED 415-MHZ RADIOFREQUENCY RADIATION(U) SCHOOL
OF AEROSPACE MEDICINE BROOKS AFB TX R R BIXBY NOV 86
USAFSAM-TR-86-29 F/G 6/18 NL

UNCLASSIFIED

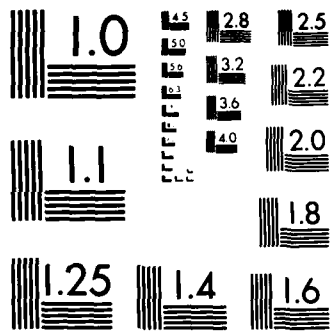



MICROCOPY RESOLUTION TEST CHART
NATIONAL BUREAU OF STANDARDS-1963-A

12

USAFSAM-TR-86-29

AD-A174 907

**AN EVALUATION OF FLASHLIGHTS
EXPOSED TO CONTINUOUS-WAVE AND
PULSED 415-MHz RADIOFREQUENCY
RADIATION**

R. Richard Bixby, B.S

DTIC
ELECTE
DEC 9 1986
S
A B

November 1986

Final Report for Period October 1984 - December 1984

DTIC FILE COPY

Approved for public release; distribution is unlimited.

USAF SCHOOL OF AEROSPACE MEDICINE
Aerospace Medical Division (AFSC)
Brooks Air Force Base, TX 78235-5301



86 12 09 104

UNCLASSIFIED

ADA 174907

SECURITY CLASSIFICATION OF THIS PAGE

REPORT DOCUMENTATION PAGE

1a. REPORT SECURITY CLASSIFICATION UNCLASSIFIED		1b. RESTRICTIVE MARKINGS	
2a. SECURITY CLASSIFICATION AUTHORITY		3. DISTRIBUTION / AVAILABILITY OF REPORT Approved for public release; distribution is unlimited.	
2b. DECLASSIFICATION / DOWNGRADING SCHEDULE			
4. PERFORMING ORGANIZATION REPORT NUMBER(S) USAFSAM-TR-86-29		5. MONITORING ORGANIZATION REPORT NUMBER(S)	
6a. NAME OF PERFORMING ORGANIZATION USAF School of Aerospace Medicine	6b. OFFICE SYMBOL (if applicable) USAFSAM/RZP	7a. NAME OF MONITORING ORGANIZATION	
6c. ADDRESS (City, State, and ZIP Code) Aerospace Medical Division (AFSC) Brooks Air Force Base, Texas 78235-5301		7b. ADDRESS (City, State, and ZIP Code)	
8a. NAME OF FUNDING / SPONSORING ORGANIZATION USAF School of Aerospace Medicine	8b. OFFICE SYMBOL (if applicable) USAFSAM/RZP	9. PROCUREMENT INSTRUMENT IDENTIFICATION NUMBER	
8c. ADDRESS (City, State, and ZIP Code) Aerospace Medical Division (AFSC) Brooks Air Force Base, Texas 78235-5301		10. SOURCE OF FUNDING NUMBERS	
		PROGRAM ELEMENT NO. 62202F	PROJECT NO. 7757
		TASK NO. 01	WORK UNIT ACCESSION NO. 82
11. TITLE (Include Security Classification) An Evaluation of Flashlights Exposed to Continuous-Wave and Pulsed 415-MHz Radiofrequency Radiation			
12. PERSONAL AUTHOR(S) Bixby, R. Richard			
13a. TYPE OF REPORT Final Report	13b. TIME COVERED FROM 10/1/84 TO 12/31/84	14. DATE OF REPORT (Year, Month, Day) 1986, November	15. PAGE COUNT 12
16. SUPPLEMENTARY NOTATION			
17. COSATI CODES			18. SUBJECT TERMS (Continue on reverse if necessary and identify by block number) AN/FPS-92 radar, Incandescence threshold, Dosimetry, Radiofrequency radiation, Flashlight,
FIELD	GROUP	SUB-GROUP	
06	02		
06	18		
19. ABSTRACT (Continue on reverse if necessary and identify by block number) An experiment was conducted in which flashlights were exposed to continuous-wave (CW) and pulsed (2-ms pulse width and 27 pulses/s) 415-MHz radiofrequency radiation (RFR); the objective was to determine if and under what RFR exposure conditions the flashlights would exhibit self-switching. The impetus for this effort was provided by a possible RFR overexposure incident on September 14, 1983 at the Clear Air Force Station (AFS) ballistic missile early warning system (BMEWS) site. It was recorded that some personnel, within the exposure volume, noticed their flashlights "neoning". In our study, each flashlight was irradiated in the E, H, and k orientations and in the far- and near-field radiation zones. The thresholds of incandescence and the electric field strength for bulb burnout were measured.			
20. DISTRIBUTION / AVAILABILITY OF ABSTRACT <input checked="" type="checkbox"/> UNCLASSIFIED/UNLIMITED <input type="checkbox"/> SAME AS RPT. <input type="checkbox"/> DTIC USERS		21. ABSTRACT SECURITY CLASSIFICATION UNCLASSIFIED	
22a. NAME OF RESPONSIBLE INDIVIDUAL R. Richard Bixby		22b. TELEPHONE (Include Area Code) 512/536-2209	22c. OFFICE SYMBOL USAFSAM/RZP

DD FORM 1473, 84 MAR

83 APR edition may be used until exhausted.

All other editions are obsolete.

SECURITY CLASSIFICATION OF THIS PAGE

UNCLASSIFIED

AN EVALUATION OF FLASHLIGHTS EXPOSED TO CONTINUOUS-WAVE AND PULSED 415-MHz RADIOFREQUENCY RADIATION

INTRODUCTION

On September 14, 1983, several maintenance personnel at the 13th Ballistic Missile Early Warning System (BMEWS) Site II, Clear Air Force Station (AFS), Alaska were exposed to pulsed (2-ms pulse width and 27 pulses/s) 417-MHz radiofrequency radiation (RFR) from an AN/FPS-92 radar [1]. The facility contains a 25.6-m (84-ft) diameter parabolic dish reflector enclosed within a radome. While standing on this reflector, some maintenance personnel noticed their flashlight bulbs "neoning," a fact that alerted them to their exposure [2]. The term "neoning" describes the "switching on" of a lamp (e.g., a fluorescent lightbulb) by an incident electromagnetic (EM) field. These observations prompted a USAFSAM/RZP investigation into the behavior of similar flashlights exposed to RFR. The purpose of this study was to measure the flashlight incandescence thresholds and the radiofrequency (RF) power levels needed to destroy the lightbulbs. Incandescence threshold is defined as the level of incident EM power density necessary to elicit a perceptible glow of the flashlight bulb's tungsten filament. This measurement is subjective, depending on the observer's visual acuity.

MATERIALS AND METHODS

Six olive drab flashlights, manufactured by the Fulton, Co. (NSN 6230-00-163-1856), were supplied by Clear AFS for this evaluation. Each flashlight is approximately 20-cm (8-in.) long by 5-cm (2-in.) diameter, powered by 2 D cells (3 VDC), and has three switch positions: off, push-button mode (intermittent operation), and on (continuous operation). The flashlights were exposed in an Emerson and Cuming, Inc. 200-MHz - 30-GHz Eccosorb (TM) anechoic chamber to 415-MHz radiation from a square corner reflector antenna characterized by a horizontal, half-wavelength feed dipole located 21.6 cm (8.5 in.) (0.3 wavelength) from the reflector vertex [3] (Fig. 1). Each flashlight was centered at boresight distances of 1.00 m (3 ft), 0.50 m (1.5 ft), and 0.30 m (1 ft) from the antenna vertex and irradiated in the E, H, and k orientations; each orientation being achieved by aligning the long axis of the flashlight with the direction of the incident electric (E) field, the incident magnetic (H) field, or the EM wave propagation direction (k). For this antenna and frequency, the boundary of the far-field radiation zone was taken as 0.58 m (1.9 ft) (0.8 wavelength) from the reflector vertex. The evaluation consisted of both continuous-wave (CW) exposures and pulse-mode exposures of 27 pulses/s and 2-ms pulse width.

The source of the CW and pulsed 415-MHz RFR was a Microwave Cavity Laboratories, Inc. (MCL) model 15222 RF power generator (with an MCL model 6049, 200-500-MHz plug-in) which drove an MCL model 10110B power amplifier (with an MCL model 11145, 400-800-MHz plug-in). The amplified RF signal was transmitted to a double stub tuner via RG-318/U coaxial waveguide, and from the double stub to the corner reflector antenna through another section of RG-318/U coax. The dipole antenna and transmission line assembly were considered lossless; thus, the power available to the antenna for radiation was given as the difference between the measured incident and reflected powers.

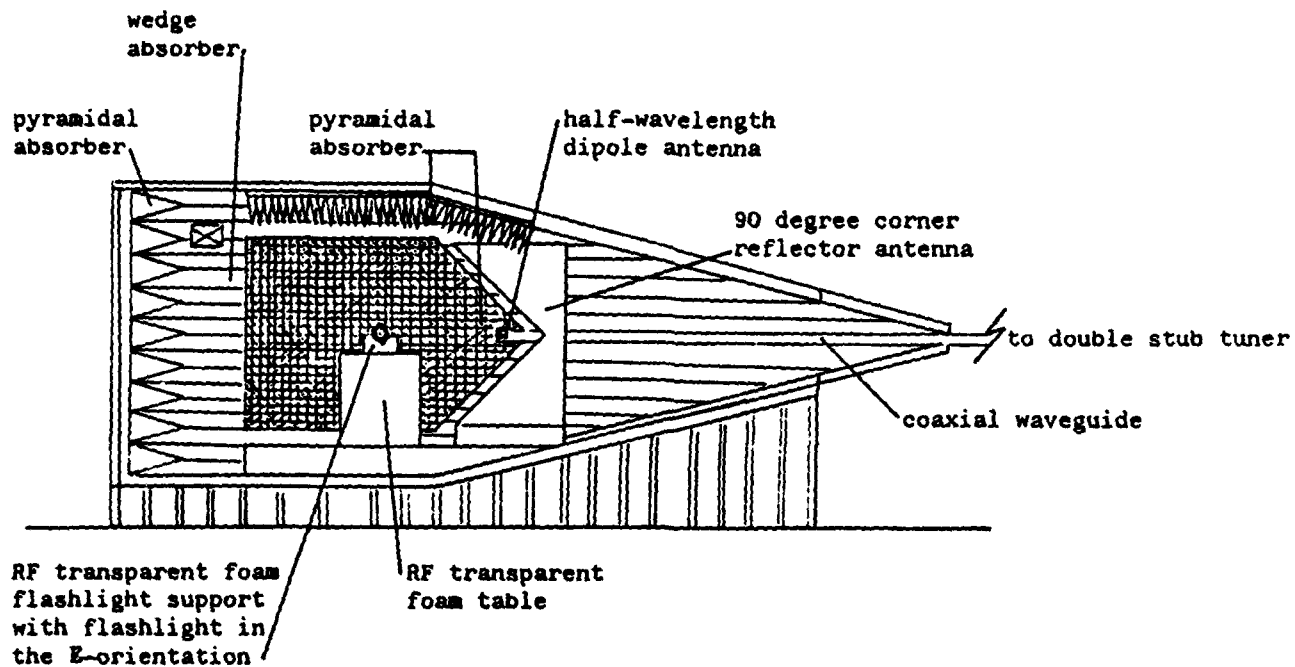

Figure 1. Emerson and Cuming, Inc. 200-MHz - 30-MHz Eccosorb anechoic chamber (S/N 966) used in the 415-MHz exposures of flashlights.

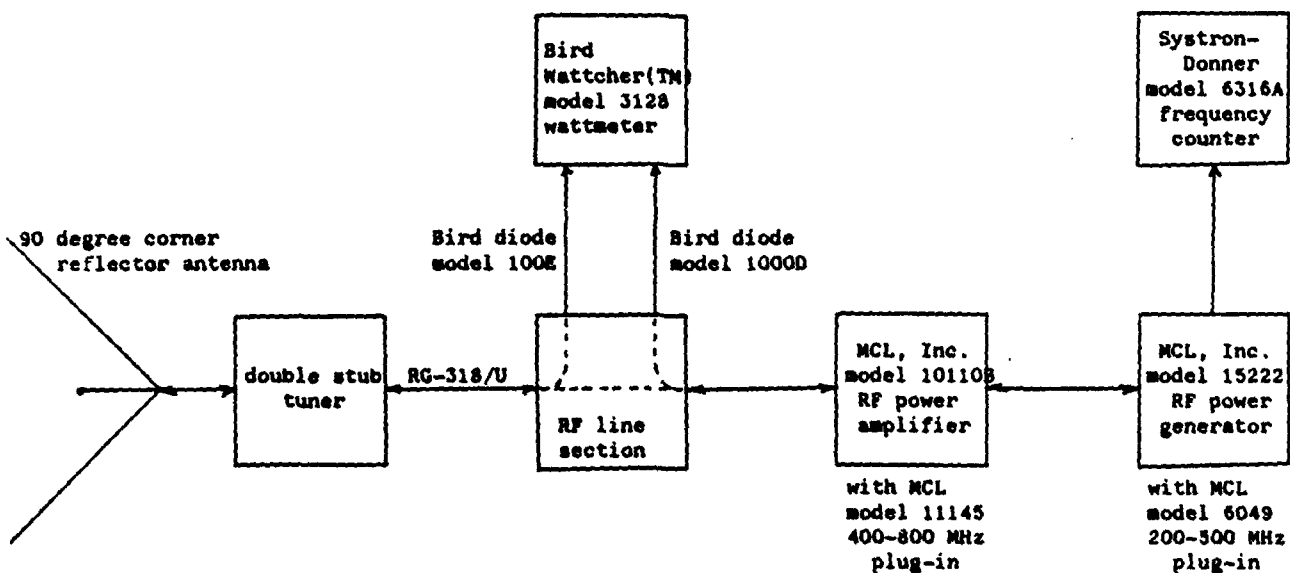

Figure 2. The 415-MHz CW exposure arrangement.

For the CW exposures, the incident and reflected RF powers were detected by Bird diodes, models 1000D and 100E respectively, that were located in an RF line section between the power amplifier and double stub tuner. These powers were measured by a Bird Wattcher (TM) model 3128 wattmeter. The radiation frequency was measured with a Systron-Donner model 6316A frequency meter, through the RF sample port on the MCL power generator. The CW exposure setup is shown in Figure 2.

For pulsed-mode operation, a Hewlett-Packard (HP) model 8011A pulse generator modulated the RF power generator output. The average incident and reflected powers were measured with HP model 432B power meters through padded National Bureau of Standards (NBS) 10 - 400-MHz directional couplers with total coupling ratios of 58 dB and 37 dB, respectively. The coupling ratios were measured at 415 MHz using an HP model 8566A spectrum analyzer. The frequency and pulse parameters were detected by a square loop antenna (22 cm x 22 cm) (8.7 in. x 8.7 in.) horizontally placed in the anechoic chamber and connected to a Tektronix model 7834 dual-trace oscilloscope by RG-58 shielded coaxial conductor. The pulsed exposure setup is shown in Figure 3.

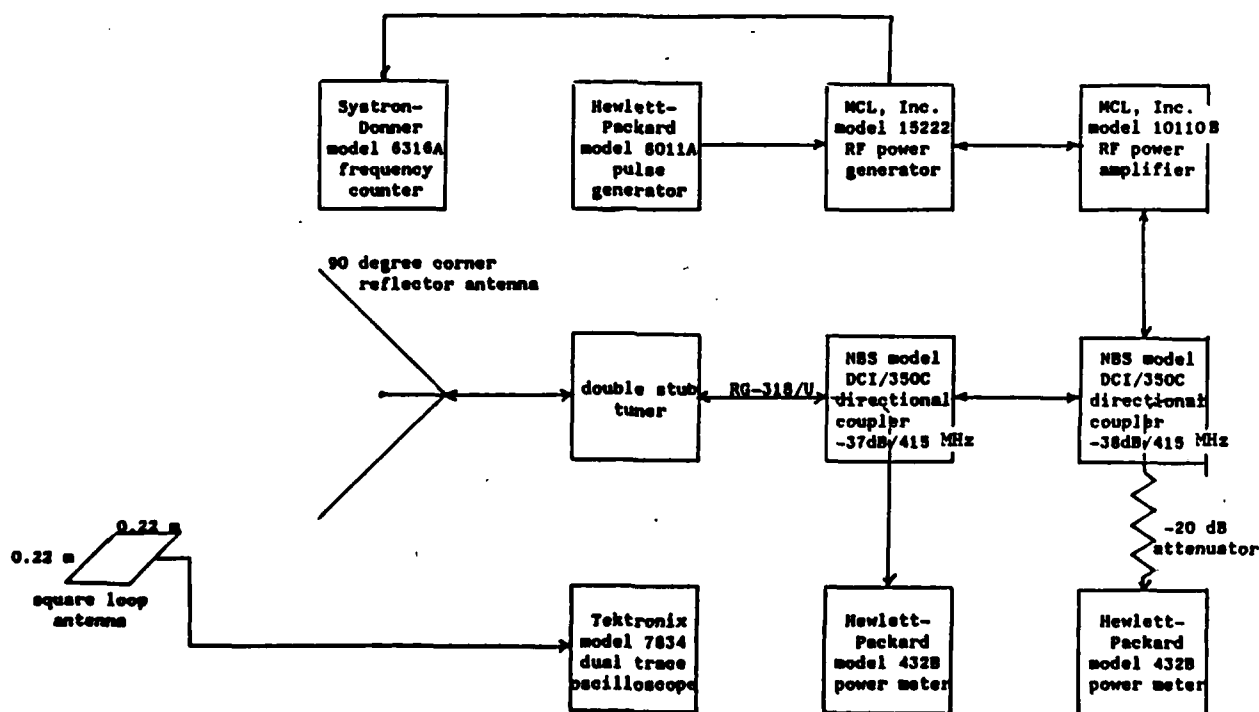

Figure 3. The 415-MHz pulsed-mode exposure arrangement.

RESULTS

In the H and k flashlight orientations, light bulb incandescence did not occur for the 0.30-m (1-ft), 0.50-m (1.5-ft), and 1.00-m (3-ft) boresight distances and maximum transmitter powers, in both the continuous-wave and pulsed evaluations. However, for the E orientation, thresholds of incandescence were noted at the 0.50-m (1.5-ft) and 1.00-m (3-ft) distances in the CW mode and the 0.30-m (1-ft) distance in the pulsed RF mode. To measure these thresholds, the flashlight was either left off or turned to the push-button mode, positioned in the chamber, and exposed to a slowly increasing 415-MHz RFR to the point where there was a noticeable filament glow. The transmitter power was noted and the flashlight was removed from the chamber, and a Narda model 8644 Isotropic E-Field Probe was set in its place; the RF transmitter output was brought up to the incandescence threshold level and the incident power density was measured by a Narda model 8616 Electromagnetic Radiation Monitor. At 1.00 m (3 ft), the incident RF power density was used as a measure of incandescence threshold; however, since the 0.30-m (1-ft) and 0.50-m (1.5-ft) positions were within the corner reflector antenna's near-field radiation zone, the electric field strength, rather than power density, was quoted as the incandescence threshold. Electric field strength was determined from the Narda power density measurements:

$$E = \sqrt{[3770 \times \text{normalized power density (mW/cm}^2\text{-W)} \times \text{transmitted power (W)}]} \text{ (V/m)}$$

where the normalized power density is the measured power density divided by the transmitted power. The measurements of the magnetic field strength were begun, but the magnetic field probe failed during the measurements. The measured incandescence thresholds are given in Tables 1 through 3.

Besides the incandescence threshold measurements, the power levels necessary for bulb burnout were recorded. Each flashlight was switched on, aligned parallel to the electric field, placed along the antenna boresight at 1.00 m (3 ft) from the vertex, and exposed to 415-MHz CW radiation. At this distance, the maximum transmitter output power was not sufficient to destroy the filaments, so the flashlights were repositioned 0.50 m (1.5 ft) from the antenna vertex. As the transmitter power was increased, a pulsing orange plasma formed within the light bulb, a sign that filament failure was imminent. The intensity of the plasma increased for about 10 - 20 s until the discharge ceased; at this time, the transmitter power was noted and dosimetry was performed with the Narda meter and probe as just described. The electric fields necessary to destroy the bulbs are recorded in Table 2.

CONCLUSION

The type of flashlight used at the Clear AFS BMEWS site does respond to the RFR from the AN/FPS-92 radar. However, it is impossible to quantify the EM power density incident on the exposed workers, based on their "neoning" flashlights, since it would be necessary to perfectly reconstruct the scenario and have a measured relationship between light bulb incandescence and the incident electric field. Because we could not elicit incandescence thresholds

in the H and k orientations, nor bulb burnout in the pulse mode, does not mean these values do not exist; we were limited in our transmitted RF power capabilities by the equipment used.

ACKNOWLEDGEMENTS

The author thanks SSgts. Richard C. Elder, James W. Heathcock, Ronald R. Johnson, Jr., Steven F. Schroeder, and Sgt. Zant L. Chapelo for their assistance in this experiment.

REFERENCES

1. Nuss, D.A. Investigation of RF Overexposure Incident, Clear AFS, Alaska. Bioenvironmental Engineering Survey, Alaskan Air Command, 22-23 Sep 1983.
2. Report of Investigation: Tracker radar radiation incident on 14 Sep 1983, Clear BMEWS, Alaska. FELEC Services, Inc.
3. Kraus, J.D. Antennas, Chapter 12. New York: McGraw-Hill Book Co., 1950.



DTIC
SELECTED
DEC 9 1986

B

Ac...
A-1

TABLE 1. INCANDESCENCE THRESHOLDS FOR 1.00-m (3-ft) CW EXPOSURES OF FLASHLIGHTS IN THE E ORIENTATION.

Flashlight No.	Transmitted power (W)			Switch position and orientation*		Power density (mW/cm ²)
	Inc	Refl	Trans			
2	640	8	632	OFF	↑	92
	620	8	612	PB	↑	(no output at 89 mW/cm ²)
	650	9	641	OFF	→	(no output at 94 mW/cm ²)
	630	8	622	PB	→	(no output at 91 mW/cm ²)
	620	8	612	OFF	↓	89
	600	8	592	PB	↓	86
	580	9	571	OFF	←	83
	520	6	514	PB	←	75
3	520	6	514	OFF	↑	75
	480	6	474	PB	↑	69
	560	7	553	OFF	→	81
	520	6	514	PB	→	75
	540	7	533	OFF	↓	78
	490	6	484	PB	↓	71
	480	6	474	PB,OFF	←	69
4	620	9	611	PB,OFF	↑	(no output at 90 mW/cm ²)
	620	9	611	PB,OFF	→	(no output at 90 mW/cm ²)
	620	9	611	PB,OFF	↓	(no output at 90 mW/cm ²)
	620	9	611	PB,OFF	←	(no output at 90 mW/cm ²)
5	640	12	628	PB,OFF	↑	(no output at 92 mW/cm ²)
	640	10	630	PB,OFF	→	(no output at 92 mW/cm ²)
	640	12	628	PB,OFF	↓	(no output at 92 mW/cm ²)
	640	12	628	PB,OFF	←	(no output at 92 mW/cm ²)
6	440	5	435	OFF	↑	64
	420	5	415	PB	↑	61
	445	4	441	OFF	→	65
	440	4	436	PB	→	64
	440	5	435	PB,OFF	↓	64
	370	4	366	PB,OFF	←	54

* ↑ : indicates that the flashlight switch pointed up
 ↓ : indicates that the flashlight switch pointed down
 → : indicates that the flashlight switch pointed toward the antenna
 ← : indicates that the flashlight switch pointed away from the antenna
 PB : push-button mode

TABLE 2. INCANDESCENCE THRESHOLDS AND BULB-BURNOUT E FIELD STRENGTHS FOR 0.50-m (1.5-ft) CW EXPOSURES OF FLASHLIGHTS IN THE E ORIENTATION.

Flashlight No.	Transmitted power (W)			Switch position and orientation*	Electric field strength (V/m)
	Inc	Refl	Trans		
2	180	1	179	PB,OFF ↑	608
	180	2	178	PB,OFF →	608
	150	1	149	PB,OFF ↑	556
	150	1	149	PB,OFF ←	556
	360	23	337	ON ↑	836
3	100	1	99	PB,OFF ↑	451
	120	1	119	PB,OFF →	495
	100	1	99	PB,OFF ↓	451
	100	1	99	OFF ←	451
	90	1	89	PB ←	430
	140	10	130	ON ↑	519
4	140	1	139	PB,OFF ↑	535
	140	1	139	PB,OFF →	535
	150	1	149	OFF ↓	556
	140	1	139	PB ↓	535
	180	1	179	PB,OFF ←	608
	240	2	238	ON ↑	702
	5	270	1	269	PB ↑
260		1	259	OFF ↑	732
260		1	259	PB,OFF →	732
260		1	259	PB,OFF ↓	732
230		1	229	OFF ←	689
220		1	219	PB ←	673
360		3	357	ON ↑	860
6	100	1	99	PB,OFF ↑	451
	100	1	99	PB,OFF →	451
	100	1	99	PB,OFF ↓	451
	80	1	79	PB,OFF ←	403
	320	3	317	ON ↑	811

* ↑ : indicates that the flashlight switch pointed up
 ↓ : indicates that the flashlight switch pointed down
 → : indicates that the flashlight switch pointed toward the antenna
 ← : indicates that the flashlight switch pointed away from the antenna
 PB : push-button mode

TABLE 3. INCANDESCENCE THRESHOLDS FOR 0.30-m (1-ft) PULSED EXPOSURES OF FLASHLIGHTS IN THE E ORIENTATION.

Flashlight No.	Transmitted power (W)			Switch position and orientation*		Electric field strength (V/M)
	Inc	Refl	Trans			
1	110	3	107	PB	↑	543
	107	1	106	PB	→	540
	95	3	92	PB	←	503
	114	3	111	PB	↓	553
2	158	4	154	PB	↑	651
	158	4	154	PB	↓	651
	142	2	140	PB	→	621
	126	5	121	PB	←	577
3	120	3	117	PB	↑	567
	117	1	116	PB	→	565
	126	3	123	PB	↓	582
	104	4	100	PB	←	525
4	-	-	-	PB	↑	-
	-	-	-	PB	→	-
	-	-	-	PB	←	-
	-	-	-	PB	↓	-
5	170	4	166	PB	↑	676
	148	2	146	PB	→	634
	170	4	166	PB	↓	676
	-	-	-	PB	←	-
6	101	2	99	PB	↑	522
	91	1	90	PB	→	498
	104	3	101	PB	↓	527
	91	3	88	PB	←	492

- * ↑ : indicates that the flashlight switch pointed up
 ↓ : indicates that the flashlight switch pointed down
 → : indicates that the flashlight switch pointed toward the antenna
 ← : indicates that the flashlight switch pointed away from the antenna
 PB : push-button mode

END

1-87

DTIC