

MICROCOPY RESOLUTION TEST CHART
 NATIONAL BUREAU OF STANDARDS 1963-A



GOVERNMENT SYSTEMS, Inc.

8619 WESTWOOD CENTER DRIVE
VIENNA, VIRGINIA 22180

M/A-COM GOVERNMENT SYSTEMS, INC.

Log # MSO-86-109a

Copy # 4

2

AD-A174 918

ANALYSIS OF DSCS III SHF UPGRADES

VOLUME I

Part A—Analysis of Frequency Reuse via Polarization Diversity

FINAL REPORT
December 1986

Submitted to:

Defense Communications Agency
Center for Command and Control, and
Communications Systems, Code A800
8th & S. Courthouse Road
Arlington, VA 22204

Prepared by M/A-COM Government Systems, Inc.,
Under Contract DCA100-84-C-0009.
Task MSO86-808/4, Subtask A

DTIC FILE COPY

DTIC
ELECTE
DEC 10 1986
S D
E

This document has been approved
for public release and sale; its
distribution is unlimited.

511350

CENTER FOR
COMMAND AND **C**ONTROL, AND
COMMUNICATIONS
SYSTEMS (C⁴S)

" EXCELLENCE IN C³ SYSTEMS FOR NATIONAL DEFENSE "

**ANALYSIS OF DSCS III
 SHF UPGRADES**

VOLUME I-Part A

FINAL REPORT
 December 1986

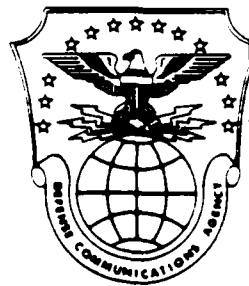

COPY
 INSPECTED

**DEFENSE
 COMMUNICATIONS
 AGENCY**

Accession For	
NTIS GRA&I	<input checked="" type="checkbox"/>
DTIC TAB	<input type="checkbox"/>
Unannounced	<input type="checkbox"/>
Justification	<i>form 30 per</i>
By	
Distribution/	
Availability Codes	
Dist	Avail and/or Special
<i>A-1</i>	

TABLE OF CONTENTS

	<u>Page</u>
EXECUTIVE SUMMARY	ES-1
ES.1 Introduction	ES-1
ES.2 Subtask A: Frequency Reuse via Polarization Diversity	ES-1
ES.2.1 Cross-Polarized Signals	ES-2
ES.2.2 Current DSCS III System	ES-2
ES.2.3 Upgraded DSCS III Satellite	ES-5
ES.2.4 Results	ES-5
ES.3 Conclusions and Recommendations	ES-11
CHAPTER 1 - INTRODUCTION	1-1
1.1 Rationale for using Dual-Polarized Signals	1-1
1.2 Overview of Signal Polarization	1-2
1.2.1 Linear Polarization	1-4
1.2.2 Circular and Elliptical Polarization	1-4
1.2.3 Orthogonal Polarizations	1-6
1.3 Cross-Coupling Effects	1-8
1.3.1 Axial Ratios	1-11
1.3.2 Depolarization Due to Rain and Ice	1-13
1.4 Polarization Tracking and Compensation	1-14
1.4.1 Restoration Method	1-17
1.4.2 Cancellation Method	1-19
1.4.3 Hybrid Method	1-21
1.4.4 Types of Predistortion Network	1-21
1.5 Current Systems Using Cross-Polarization	1-22
CHAPTER 2 - DSCS SYSTEM	2-1
2.1 Current DSCS System	2-1
2.1.1 Space Segment	2-1
2.1.2 Earth Terminals	2-5
2.2 Upgraded DSCS III Satellite	2-5
2.2.1 Wideband Cross-Polarized Channel	2-9
2.2.2 Narrowband Cross-Polarized Channel	2-9

TABLE OF CONTENTS (Continued)

	<u>Page</u>
CHAPTER 3 - METHODOLOGY	3-1
3.1 Determination of Link Signal-to-Noise Ratio (SNR)	3-1
3.2 Calculation of System Throughput	3-8
3.3 Cross-Polarized Channel Concepts	3-12
3.3.1 Scenarios for a Wideband Cross-Polarized Channel Opposite Channels 3 and 4	3-15
3.3.2 Scenarios for a Wideband Cross-Polarized Channel Opposite Channels 5 and 6	3-15
3.3.3 Scenarios for Wideband Cross-Polarized Channel Opposite Channels 1 and 2	3-27
3.3.4 Scenarios for Narrowband Cross-Polarized Channel	3-31
3.4 Minimum Acceptance Criteria	3-31
CHAPTER 4 - RESULTS	4-1
4.1 Wideband Cross-Polarized Channel	4-1
4.2 Narrowband Cross-Polarized Channel	4-17
CHAPTER 5 - CONCLUSIONS AND RECOMMENDATIONS	5-1
REFERENCES	R-1

LIST OF FIGURES

	<u>Page</u>
Figure ES-1. Link Cross-Coupling Ratio C for Various Transmit and Receive Axial Ratios No Rain Scenario	ES-3
Figure ES-2. DSCS III Transponder Channel and Antenna Connectivity Diagram	ES-4
Figure ES-3. DSCS RDT&E Strawman SHF Design	ES-6
Figure 1-1. Elliptically Polarized Wave	1-3
Figure 1-2. Linearly Polarized Wave	1-5
Figure 1-3. Circularly Polarized Wave	1-5
Figure 1-4. Axial Ratio and Tilt Angle of an Elliptically Polarized Wave	1-7
Figure 1-5. Differential Phase Shift of Two Elliptical Polarizations While Maintaining Orthogonality	1-9
Figure 1-6. Link Cross-Coupling Ratio C for Various Transmit and Receive Axial Ratios. (No Rain Scenario)	1-12
Figure 1-7. Link Cross-Coupling Ratio C for Various Transmit and Receive Axial Ratios. (-15 dB Rain Scenario)	1-15
Figure 1-8. Typical End-to-End Dual Frequency Access	1-16
Figure 1-9. Methods of Polarization Compensation . . .	1-18
Figure 1-10. Simulated INTELSAT V Dual Frequency Performance in 20 mm/hr Rain	1-24
Figure 2-1. DSCS III Transponder Channel and Antenna Connectivity Diagram	2-2
Figure 2-2. DSCS RDT&E Strawman SHF Design	2-8
Figure 2-3. Frequency Plan for DSCS III Satellite (B8 and Beyond)	2-10
Figure 2-4. Channel Filter Characteristics for DSCS III	2-12
Figure 3-1. Link E_b/N_0 vs. Ratio of Cross-Polarized Transmit EIRP to Copolarized Transmit EIRP (No Rain Case)	3-4
Figure 3-2. Link E_b/N_0 vs. Ratio of Cross-Polarized Transmit EIRP to Copolarized Transmit EIRP (With Rain)	3-5
Figure 3-3. BER vs. CNR for CPSK Signals in Presence of N Interferers	3-9
Figure 3-4. Block Diagram for Scenario 1	3-18
Figure 3-5. Block Diagram for Scenario 2	3-19
Figure 3-6. Block Diagram for Scenario 3	3-20
Figure 3-7. Block Diagram for Scenario 4	3-21
Figure 3-8. Block Diagram for Scenario 5	3-22
Figure 3-9. Block Diagram for Scenario 6	3-23
Figure 3-10. Block Diagram for Scenario 7	3-24
Figure 3-11. Block Diagram for Scenario 8	3-25

LIST OF FIGURES (Continued)

	<u>Page</u>
Figure 3-12. Block Diagram for Scenario 9	3-26
Figure 3-13. Block Diagram for Scenario 10	3-28
Figure 3-14. Block Diagram for Scenario 11	3-29
Figure 3-15. Block Diagram for Scenario 12	3-30
Figure 3-16. Block Diagram for Scenario 13	3-32
Figure 3-17. Block Diagram for Scenario 14	3-33
Figure 3-18. Block Diagram for Scenario 15	3-34
Figure 4-1. Link Data Rate vs. C_u for Scenario 1	4-2
Figure 4-2. Link Data Rate vs. C_u for Scenario 2	4-3
Figure 4-3. Link Data Rate vs. C_u for Scenario 3	4-4
Figure 4-4. Link Data Rate vs. C_u for Scenario 4	4-5
Figure 4-5. Link Data Rate vs. C_u for Scenario 5	4-6
Figure 4-6. Link Data Rate vs. C_u for Scenario 6	4-8
Figure 4-7. Link Data Rate vs. C_u for Scenario 7	4-9
Figure 4-8. Link Data Rate vs. C_u for Scenario 8	4-10
Figure 4-9. Link Data Rate vs. C_u for Scenario 9	4-11
Figure 4-10. Link Data Rate vs. C_u for Scenario 10	4-12
Figure 4-11. Link Data Rate vs. C_u for Scenario 11	4-13
Figure 4-12. Link Data Rate vs. C_u for Scenario 12	4-14
Figure 4-13. Link Data Rate vs. C_u for Scenario 13	4-19
Figure 4-14. Link Data Rate vs. C_u for Scenario 14	4-20
Figure 4-15. Link Data Rate vs. C_u for Scenario 15	4-21
Figure 4-16. Link Data Rate vs. C_u for Scenario 16	4-22
Figure 4-17. Link Data Rate vs. C_u for Scenario 17	4-23
Figure 4-18. Link Data Rate vs. C_u for Scenario 18	4-24

LIST OF TABLES

	<u>Page</u>
Table ES-1. Summary of Scenarios	ES-8
Table ES-2. Summarization of Results for Wideband Cross-Polarized Channel	ES-10
Table 2-1. Bandwidth of DSCS III Channels	2-3
Table 2-2. DSCS III Antenna Connectivity	2-3
Table 2-3. Specification Values for Axial Ratios for Current DSCS Satellite Antennas	2-4
Table 2-4. Earth Terminal Characteristics	2-6
Table 2-5. Cross-Polarization Isolation for DSCS Antenna	2-7
Table 3-1. Link E_b/N_0 Due to Cross-Polarization Noise (Without Rain--Required $E_b/N_0 = 7.5$ dB)	3-6
Table 3-2. Link E_b/N_0 Due to Cross-Polarization Noise (With Rain--Required $E_b/N_0 = 7.5$ dB)	3-7
Table 3-3. Summary of Scenarios	3-16
Table 4-1. Summarization of Results for Wideband Cross-Polarized Channel	4-12

EXECUTIVE SUMMARY

ES.1 INTRODUCTION

This report examines the benefits of proposed super high frequency (SHF) upgrades to the Defense Satellite Communications System (DSCS) III satellite. These study efforts are a direct result of the continuing effort to support DSCS/Wideband user requirements through the year 2000 timeframe and beyond. This report is structured as follows:

Volume I

Part A - Analysis of Frequency Reuse via Polarization Diversity

Volume II

Part B - Improved Spacecraft Linearization
Part C - Uplink Antenna Change

Volume III

Part D - DSCS SHF Onboard Adaptive Antenna Array Study

ES.2 SUBTASK A: FREQUENCY REUSE VIA POLARIZATION DIVERSITY

The DSCS III system is currently facing the need for increased communications capacity. A potential solution to this problem is to expand the available bandwidth via frequency reuse. One method is to use the inherent isolation that exists between oppositely polarized circular signals. The purpose of this report is to examine the feasibility of frequency reuse via the use of dual-polarized signals for the DSCS system and to determine the changes necessary to implement a dual-frequency system. It should be noted that all results presented in this report are based on specification values for the satellite and earth terminals. Recent tests performed on the DSCS system indicated that the DSCS system performance is actually better than that predicted by the specified values.

ES.2.1 Cross-Polarized Signals

The potential frequency reuse arises because ideal right-hand circularly polarized (RHCP) and left-hand circularly polarized (LHCP) signals are orthogonal. That is, even at the same frequency, ideal RHCP and LHCP signals are totally isolated and will not interfere with each other. However, purely circularly polarized signals cannot be generated with practical hardware. Thus, in practical cases, circularly polarized signals are approximated by elliptically polarized waves in which the ratio of the ellipse major diameter to minor diameter is defined as the axial ratio. For non-ideal axial ratios (i.e., axial ratio greater than unity), RHCP and LHCP signals are not perfectly orthogonal and thus a degree of interference will exist between RHCP and LHCP signals. The amount of interference is determined by the cross-coupling coefficient (C) of the link which is a function of the transmit and receive antennas axial ratio and transmission media effects such as rain and ice. As will be shown later, cross-coupling coefficients of -25 dB or smaller are required to use cross-polarized signals. Figure ES-1 shows the effect of various axial ratios on the cross-coupling coefficient. To achieve a -25-dB cross-coupling coefficient requires both transmit and receive antennas to have axial ratios less than 0.5 dB.

ES.2.2 Current DSCS III System

Figure ES-2 shows a block diagram of the DSCS III satellite (for satellites B-8 and later versions). The satellite has six channels with channel bandwidths ranging from 50 MHz and 85 MHz. The receive antennas are one 61-element multibeam receive antenna (MBR) and two earth coverage horn (ECH) antennas. The transmit antennas are two 19-element multibeam transmit antennas (MBX), two ECHs, and one gimballed dish antenna (GDA). The axial ratios of the antennas range from 5 dB for the MBR to 2.5 dB for the ECH. A wide variety of

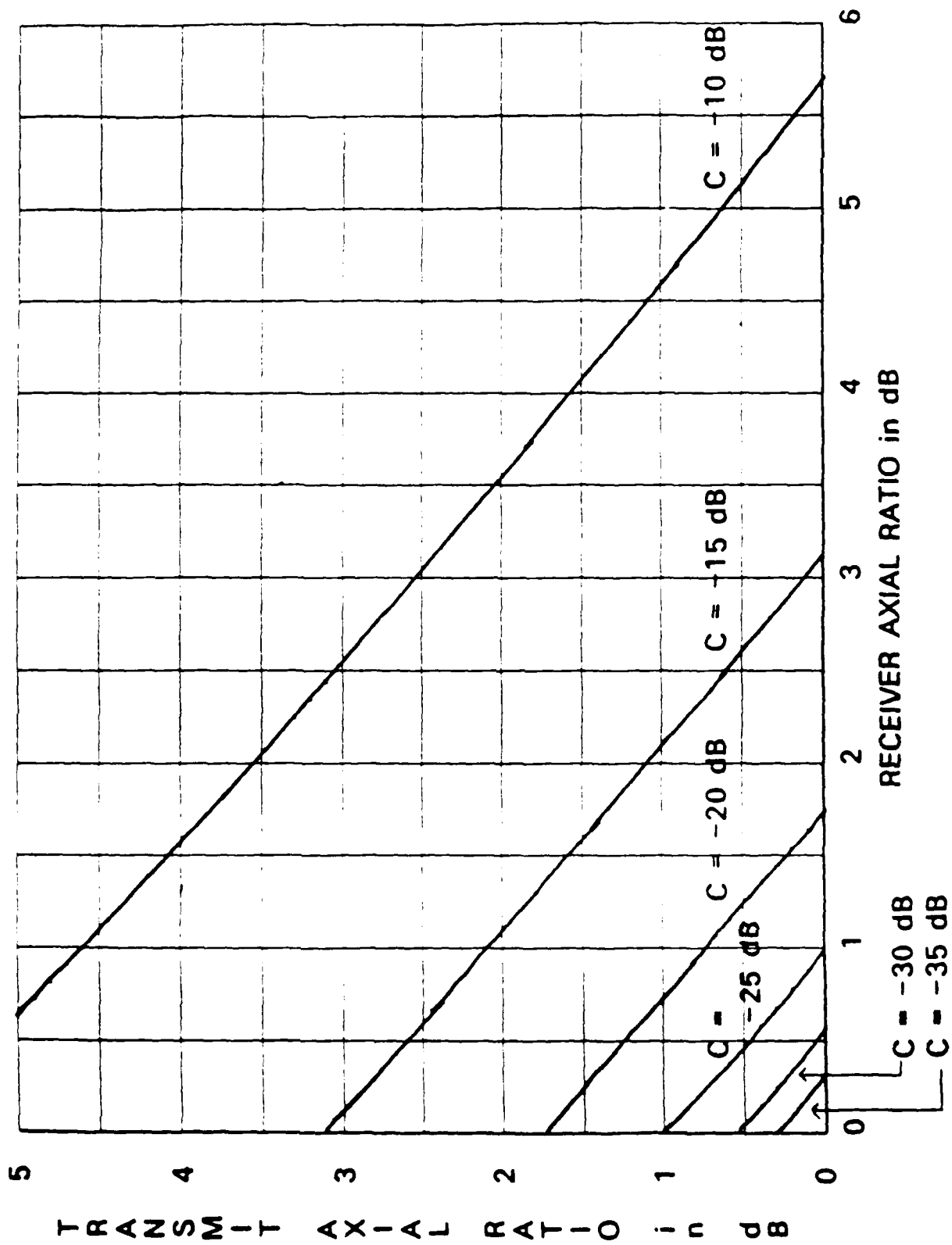
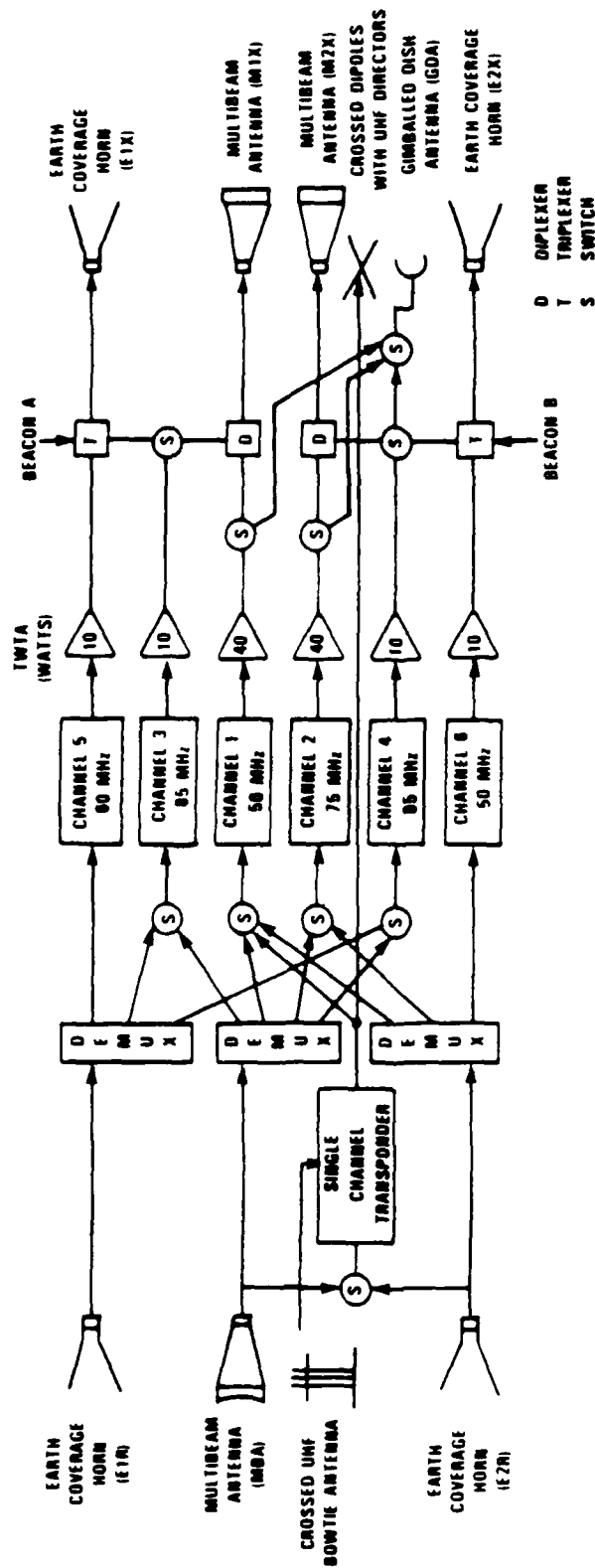

Figure ES-1. Link Cross-Coupling Ratio C for Various Transmit and Receive Axial Ratios. No Rain Scenario.



602219 0

Figure ES-2. DSCS III Transponder Channel and Antenna Connectivity Diagram

earth terminals are used in the DSCS system. These range from small 2.75-foot AN/ASC-24 to large 60-foot AN/FSC-78. Axial ratios of the earth terminal antennas range from 3 dB to 1.5 dB.

ES.2.3 Upgraded DSCS III Satellite

Figure ES-3 shows a block diagram of an upgraded DSCS III satellite developed by the DSCS Research, Development, Test and Evaluation (RDT&E) Working Group. This satellite upgrade concept would contain a cross-polarized channel. The original concept developed by the RDT&E Working Group was for a wideband cross-polarized channel (75 to 100 MHz) placed in three potential positions; opposite channels 3 and 4, opposite channels 5 and 6, or opposite channels 1 and 2. The intended user of this cross-polarized channel would be the ground mobile forces (GMF) community. Moving the GMF from channel 2 to the cross-polarized channel would then allow channel 2 to be used by electronic counter countermeasure (ECCM) users.

After initial results showed that the use of the wideband cross-polarized channel would require major upgrades to satellite and earth terminals, a second concept for the cross-polarized channel was developed. Under this concept, the cross-polarized channel would be a narrowband channel (15 to 25 MHz) and placed opposite a 25-MHz guardband. This concept would use the existing channel filters to effectively increase the isolation between the cross-polarized channel and the current channels. Potential users for the channel would be White House Communications Agency (WHCA), TACIES, and Joint Chiefs-of-Staff (JCS) Contingency.

ES.2.4 Results

To determine the impact on the DSCS system, scenarios were developed for both wideband and narrowband cross-polarized channel concepts. In all, 18 scenarios were developed: 12 for

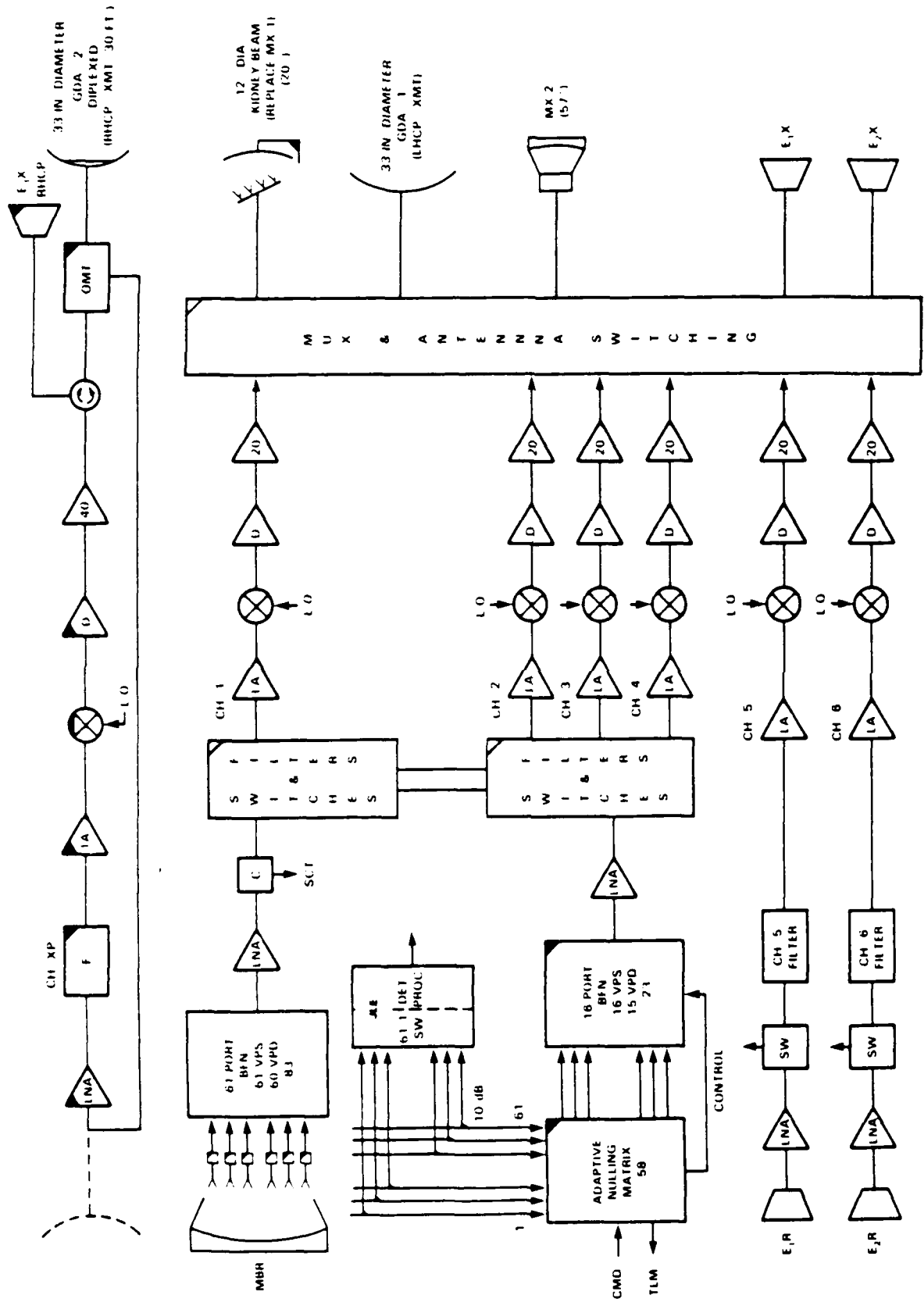

FIGURE ES-3. DCSB RDT&E STRAWMAN SHIP DESIGN

KEY
 [] NEW
 [] MODIFIED
 [] EXISTING

the wideband cross-polarized channel and 6 for the narrowband cross-polarized channel. Table ES-1 summarizes the 18 scenarios.

Table ES-2 summarizes the results for the wideband cross-polarized channel concept. For cases in which the wideband cross-polarized channel is placed opposite channels 3 and 4, or channels 5 and 6, Table ES-2a contains the values of uplink and downlink cross-coupling coefficients (C_u and C_d). The indicated cross-coupling coefficients are based on specified values of axial ratio for satellite and earth terminal antennas, the required C_u and C_d , and the postulated satellite and earth terminal axial ratios required to meet the minimum value of required C_u or C_d . For cases in which the wideband cross-polarized channel is placed opposite channels 1 and 2, Table ES-2b contains the C_u and C_d based on the specified values of axial ratio for the satellite and earth terminal antennas. For the current values of C_u and C_d , the table shows the supportable link data rate. The next two columns show the required C_u and C_d needed to achieve a link data rate of 1.5 Mbps. The last two columns show the required satellite and earth terminal antenna axial ratios needed to meet the minimum value of required C_u or C_d . Table ES-2 shows that the required end-to-end isolation (C) ranges from -18 dB to -35 dB, while the isolation values (of C) based on the current earth terminal and satellite specifications range from -8.7 dB to -11.8 dB. To achieve the required isolation, the axial ratios of the satellite and earth terminal must be greatly improved. In addition, the required axial ratios were calculated assuming no rain. To meet objectives for a 99.9 percent link availability, rain polarization compensators would be required at the earth terminals.

In contrast, results for the narrowband cross-polarized channel showed that for a 25-MHz channel, only the satellite ECH antenna axial ratio needs to be improved (from its current

Table ES-1. Summary of Scenarios

WIDEBAND CROSS-POLARIZED CHANNEL OPPOSITE CHANNELS 3 AND 4					
SCENARIO	CHANNEL ANALYZED	XMIT ET	RCV ET	CROSS-POLARIZED CHANNEL	COPOLARIZED CHANNEL
1	X-POL	TSC 93A (8-ft)	TSC 85A (8-ft)	GMF DEPLOYMENT	<ul style="list-style-type: none"> ● USE MBX IN EC MODE ● VARIOUS SIZE USERS
2	X-POL	TSC 93A (8-ft)	TSC 85A (20-ft)	GMF DEPLOYMENT	<ul style="list-style-type: none"> ● USE MBX IN EC MODE ● VARIOUS SIZE USERS
3	X-POL	TSC 93A (8-ft)	TSC 85A (8-ft)	GMF DEPLOYMENT	<ul style="list-style-type: none"> ● USE MBX IN EC MODE ● VARIOUS SIZE USERS
4	X-POL	TSC 93A (8-ft)	TSC 85A (20-ft)	GMF DEPLOYMENT	<ul style="list-style-type: none"> ● USE MBX IN AC MODE ● VARIOUS SIZE USERS
5	4	GSC 49 (8-ft)	GSC 52 (40-ft)	GMF DEPLOYMENT	<ul style="list-style-type: none"> ● USE MBX IN EC MODE ● VARIOUS SIZE USERS
WIDEBAND CROSS-POLARIZED CHANNEL OPPOSITE CHANNELS 5 AND 6					
SCENARIO	CHANNEL ANALYZED	XMIT ET	RCV ET	CROSS-POLARIZED CHANNEL	COPOLARIZED CHANNEL
6	X-POL	TSC 93A (8-ft)	TSC 85A (8-ft)	GMF DEPLOYMENT	<ul style="list-style-type: none"> ● TWO HIGH-EIRP USERS ● MANY SMALL TERMINALS
7	X-POL	TSC 93A (8-ft)	TSC 85A (20-ft)	GMF DEPLOYMENT	<ul style="list-style-type: none"> ● TWO HIGH-EIRP USERS ● MANY SMALL TERMINALS
8	X-POL	TSC 93A (8-ft)	TSC 85A (20-ft)	GMF DEPLOYMENT	<ul style="list-style-type: none"> ● NO HIGH-EIRP USERS ● MANY SMALL TERMINALS
9	6	SC 3 (8-ft)	SC 4 (35-ft)	GMF DEPLOYMENT	<ul style="list-style-type: none"> ● NO HIGH-EIRP USERS ● MANY SMALL TERMINALS
WIDEBAND CROSS-POLARIZED CHANNEL OPPOSITE CHANNELS 1 AND 2					
SCENARIO	CHANNEL ANALYZED	XMIT ET	RCV ET	CROSS-POLARIZED CHANNEL	COPOLARIZED CHANNEL
10	X-POL	TSC 85A (20-ft)	TSC 93A (8-ft)	GMF DEPLOYMENT	<ul style="list-style-type: none"> ● ECCM USERS ● 20 USERS CHANNEL <ul style="list-style-type: none"> - 4 60 ft TERMINALS - 8 20 ft TERMINALS - 8 8 ft TERMINALS
11	X-POL	TSC 85A (20-ft)	TSC 85A (20-ft)	GMF DEPLOYMENT	<ul style="list-style-type: none"> ● ECCM USERS ● 20 USERS CHANNEL <ul style="list-style-type: none"> - 4 60 ft TERMINALS - 8 20 ft TERMINALS - 8 8 ft TERMINALS
12	X-POL	TSC 93A (8-ft)	TSC 85A (8-ft)	GMF DEPLOYMENT	<ul style="list-style-type: none"> ● ECCM USERS ● 20 USERS CHANNEL <ul style="list-style-type: none"> - 4 60 ft TERMINALS - 8 20 ft TERMINALS - 8 8 ft TERMINALS

6111700

Table ES-1. Summary of Scenarios (Continued)

NARROWBAND CROSS-POLARIZED CHANNEL (25 MHz)					
SCENARIO	CHANNEL ANALYZED	XMIT ET	RCV ET	CROSS-POLARIZED CHANNEL	COPOLARIZED CHANNEL
13	X-POL	20-ft HUB	LST-8000 (6-ft)	<ul style="list-style-type: none"> ● VARIOUS SIZE TERMINALS ● 15 LINKS 	<ul style="list-style-type: none"> ● CHANNEL 6-MANY SMALL TERMINALS ● CHANNEL 1 <ul style="list-style-type: none"> - ECCM NETWORK - VARIOUS SIZE USERS
14	1	GSC-49 (8-ft)	GSC-39 (38-ft)	<ul style="list-style-type: none"> ● VARIOUS SIZE TERMINALS ● 15 LINKS 	<ul style="list-style-type: none"> ● CHANNEL 6-MANY SMALL TERMINALS ● CHANNEL 1 <ul style="list-style-type: none"> - ECCM NETWORK - VARIOUS SIZE USERS
15	6	SC-1 (6-ft)	SC-4 (38-ft)	<ul style="list-style-type: none"> ● VARIOUS SIZE TERMINALS ● 15 LINKS 	<ul style="list-style-type: none"> ● CHANNEL 6-MANY SMALL TERMINALS ● CHANNEL 1 <ul style="list-style-type: none"> - ECCM NETWORK - VARIOUS SIZE USERS
NARROWBAND CROSS-POLARIZED CHANNEL (15 MHz)					
SCENARIO	CHANNEL ANALYZED	XMIT ET	RCV ET	CROSS-POLARIZED CHANNEL	COPOLARIZED CHANNEL
16	X-POL	20-ft HUB	LST-8000 (6-ft)	<ul style="list-style-type: none"> ● VARIOUS SIZE TERMINALS ● 15 LINKS 	<ul style="list-style-type: none"> ● CHANNEL 6-MANY SMALL TERMINALS ● CHANNEL 1 <ul style="list-style-type: none"> - ECCM NETWORK - VARIOUS SIZE USERS
17	1	GSC-49 (8-ft)	GSC-39 (38-ft)	<ul style="list-style-type: none"> ● VARIOUS SIZE TERMINALS ● 15 LINKS 	<ul style="list-style-type: none"> ● CHANNEL 6-MANY SMALL TERMINALS ● CHANNEL 1 <ul style="list-style-type: none"> - ECCM NETWORK - VARIOUS SIZE USERS
18	6	SC-1 (6-ft)	SC-4 (38-ft)	<ul style="list-style-type: none"> ● VARIOUS SIZE TERMINALS ● 15 LINKS 	<ul style="list-style-type: none"> ● CHANNEL 6-MANY TERMINALS ● CHANNEL 1 <ul style="list-style-type: none"> - ECCM NETWORK - VARIOUS SIZE USERS

Table ES-2. Summarization of Results for Wideband Cross-Polarized Channel

(a) WIDEBAND CROSS-POLARIZED CHANNEL OPPOSITE CHANNELS 3 AND 4 OR CHANNELS 5 AND 6

SCENARIO	ACTUAL C_U^1 (dB)	ACTUAL C_d^1 (dB)	REQUIRED MAX. C_U^2 (dB)	REQUIRED MAX. C_d^3 (dB)	POSTULATED AXIAL RATIO (IN dB)	
					S/C	ET
1	-11.8	-11.8	-19	-10	0.50	1.45
2	-11.8	-9.3	-25	-10	0.50	0.50
3	-11.8	-11.8	-18	-10	0.50	1.69
4	-11.8	-9.3	-27	-13	0.40	0.40
5	-8.7	-8.7	-10	-25.5	0.46	0.46
6	-11.8	-11.8	-27	-10	0.40	0.40
7	-11.8	-9.3	-35	-10	0.15	0.15
8	-11.8	-9.3	-18	-10	0.50	1.69
9	-11.8	-11.8	-18	-22.5	0.50	0.80

(b) WIDEBAND CROSS-POLARIZED CHANNEL OPPOSITE CHANNELS 1 AND 2

SCENARIO	ACTUAL C_U^1 (dB)	ACTUAL C_d^1 (dB)	SUPPORTABLE DATA RATE ⁴ (kbps)	REQUIRED MAX. $C_U^{2,5}$ (dB)	REQUIRED MAX. $C_d^{3,5}$ (dB)	POSTULATED AXIAL RATIO (IN dB)	
						S/C	ET
10	-10.9	-11.8	290	-24	-10	0.50	0.60
11	-10.9	-9.3	366	-18.5	-10	0.50	1.57
12	-10.9	-11.8	260	-28.5	10	0.33	0.33

¹ ASSUMES SPECIFIED VALUES OF AXIAL RATIO FOR CURRENT EARTH TERMINAL AND SATELLITE ANTENNAS

² ASSUMES PERFECT DOWNLINK ($C_d = \infty$)

³ ASSUMES PERFECT UPLINK ($C_U = -\infty$)

⁴ ASSUMES 4-dB LINK MARGIN

⁵ TO ACHIEVE LINK DATA RATE OF 1.5 Mbps

value of 2.5 dB to 0.75 dB) to achieve required throughputs. No improvements to earth terminals would be required for a 25-MHz narrowband cross-polarized channel. For a 15-MHz channel, no improvements to either the satellite or earth terminal antennas are required.

ES.3 CONCLUSIONS AND RECOMMENDATIONS

Results of the study indicate that implementation of a wideband cross-polarized channel requires link polarization isolation of at least 25 dB. This requires all satellite and earth terminal axial ratios to be improved to 0.5 dB. In addition, polarization compensators would also have to be installed at the earth terminals to meet the 99.9 percent link availability. Because of the large number of terminals that would have to be upgraded (approximately 400), it is recommended that a wideband cross-polarized channel not be implemented. However, results show that implementation of a narrowband cross-polarized channel would not require any changes to the earth terminals, and, if the cross-polarized channel bandwidth is reduced 15 MHz, no changes are required for any satellite antenna. A 25-MHz channel would require the axial ratios of the satellite's ECH antennas to be improved to 0.75 dB. User terminals accessing the cross-polarized channels would require an upgrade to reverse their uplink and downlink feed polarization; however, this is considered a modest upgrade and would only impact users of the cross-polarized channel resource.

Recently, tests have been performed using the 38-foot GSC-52 and 8-foot GSC-49 terminals to determine link cross-coupling coefficients (C). Results showed that C ranged from -25 to -30 dB for the GSC-52 terminal and from -20 to -25 dB for the GSC-49 terminal. This would indicate that the axial ratios of both the satellite and earth terminals were substantially better than their specification values. Also, the

values of isolation C obtained in the test are close to the values that the analysis showed is needed to achieve the required throughputs. However, two points must be made. First, the tests were performed in clear weather and second, they were performed on only two terminals. Further tests are needed to determine if all terminals will perform this much better than their specified values. If additional testing indicates that most terminals perform much better than their specifications would indicate, then the results developed in this report should be reexamined to determine the feasibility of the wideband cross-polarized channel cases that were not considered feasible here without major terminal and space segment upgrades.

CHAPTER 1 INTRODUCTION

The DSCS/Wideband studies have indicated a number of potential DSCS III SHF improvements could be made for the mid- and far-term periods including frequency reuse through polarization diversity. This report examines the feasibility of frequency reuse for the DSCS III, and analyzes the changes necessary to implement a dual-frequency system.

1.1 RATIONALE FOR USING DUAL-POLARIZED SIGNALS

The DSCS III system is currently facing the need for increased communications capacity. A potential solution to this problem is to expand the available bandwidth via frequency reuse. This can be achieved in two ways. The first possibility is to spatially separate signals operating at the same frequency by use of narrow and area coverage antenna modes. The second method is to use the inherent isolation that exists between oppositely polarized circular signals. Frequency reuse via dual-polarized signals has a number of operational advantages over spatial isolation. Spatial isolation requires that certain earth coverage areas use particular frequencies and polarizations. Mobile DSCS ground terminals such as ships and aircraft would therefore be required to switch frequencies and polarizations depending upon location. Operationally, it would be very difficult to implement this scheme for the DSCS. Frequency reuse through polarization diversity is a more viable alternative. Currently DSCS earth terminals transmit right hand circularly polarized (RHCP) signals and receive left hand circularly polarized (LHCP) signals. Redesign of the system so that DSCS antennas could also transmit LHCP and receive RHCP could potentially double the bandwidth. This report examines the problems that must be solved to implement frequency reuse with the DSCS III

and also calculates the increased throughput obtainable for a number of different oppositely polarized frequency reuse concepts.

1.2 OVERVIEW OF SIGNAL POLARIZATION

As a radio wave propagates through free space, in general, both the magnitude and the direction of the waves electric field vector will vary as a function of space and time. The polarization of a radio wave is defined by the time varying behavior of its electric field vector at some fixed point in space. The electric field of a radio wave traveling in the -Z direction can be written as

$$E(z,t) = u_x E_x \cos(\omega t + kz + p_x) + u_y E_y \cos(\omega t + kz + p_y) \quad (1-1)$$

where $k = 2\pi/\text{wavelength}$, u_x and u_y are unit vectors in the x and y directions, and p_x and p_y are arbitrary phase angles.

In free space the electric field vector is perpendicular to the direction of propagation. Figure 1-1 shows that in this normal plane (which is a fixed point in space), an ellipse is traversed by the tip of the electric field vector as time progresses. This is referred to as elliptical polarization. If the direction of the electric field vector does not change versus time, the wave is linearly polarized. If the tip of the electric field vector traces out a circle, the signal is circularly polarized. Linear and circular polarizations are both special cases of elliptical polarization.

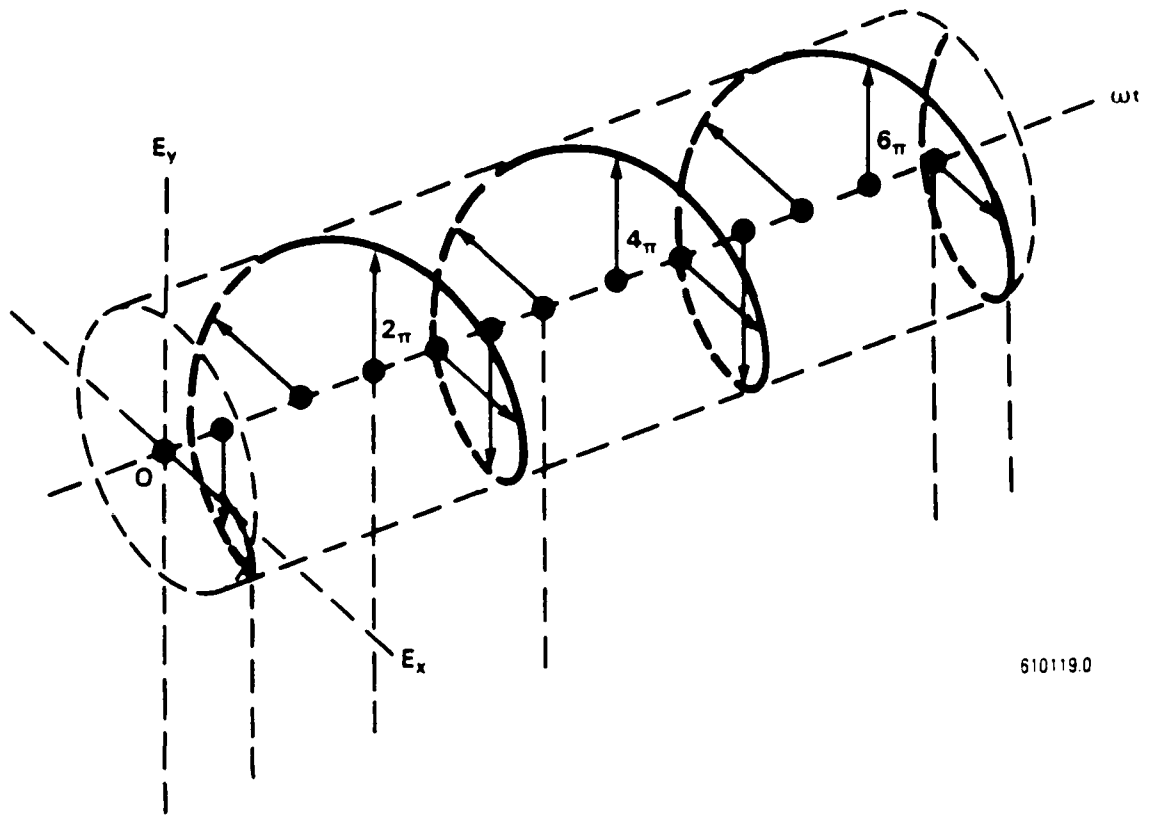

610119.0

Figure 1-1 Elliptically Polarized Wave

1.2.1 Linear Polarization

Linear polarization is obtained if both the x and y components of the electric field are in time phase or are out of phase by multiples of 180° ($p_y = p_x + n\pi$). In such a case, equation (1-1) simplifies to:

$$E(z,t) = [u_x E_x \pm u_y E_y] \cos(\omega t + kz + p_x). \quad (1-2)$$

For a linearly polarized wave, $E(z,t)$ will only depend on the magnitudes of E_x and E_y and the angle that $E(z,t)$ makes with the x-axis will remain constant over time; i.e., the field vector $E(z,t)$ always points in the same direction in the x-y plane and the signal is linearly polarized as shown in Figure 1-2.

1.2.2 Circular and Elliptical Polarization

Circular polarization is obtained when the time phase difference between the u_x and u_y components of $E(z,t)$ are separated by odd multiples of 90° and the magnitudes of the two components are equal. In such a case

$$E(z,t) = E_x [u_x \cos(\omega t + kz + p_x) \pm u_y \sin(\omega t + kz + p_x)] \quad (1-3)$$

and a circle will be drawn out in the plane normal to the direction of propagation as shown in Figure 1-3.

Elliptical polarization results whenever the phase difference between the two components is not equal to an odd multiple of 90° or if the phase difference equals an odd multiple of 90° but the magnitudes of the two components are unequal. Elliptical polarization is the general case of wave polarization, and is shown in Figure 1-1. Elliptical and

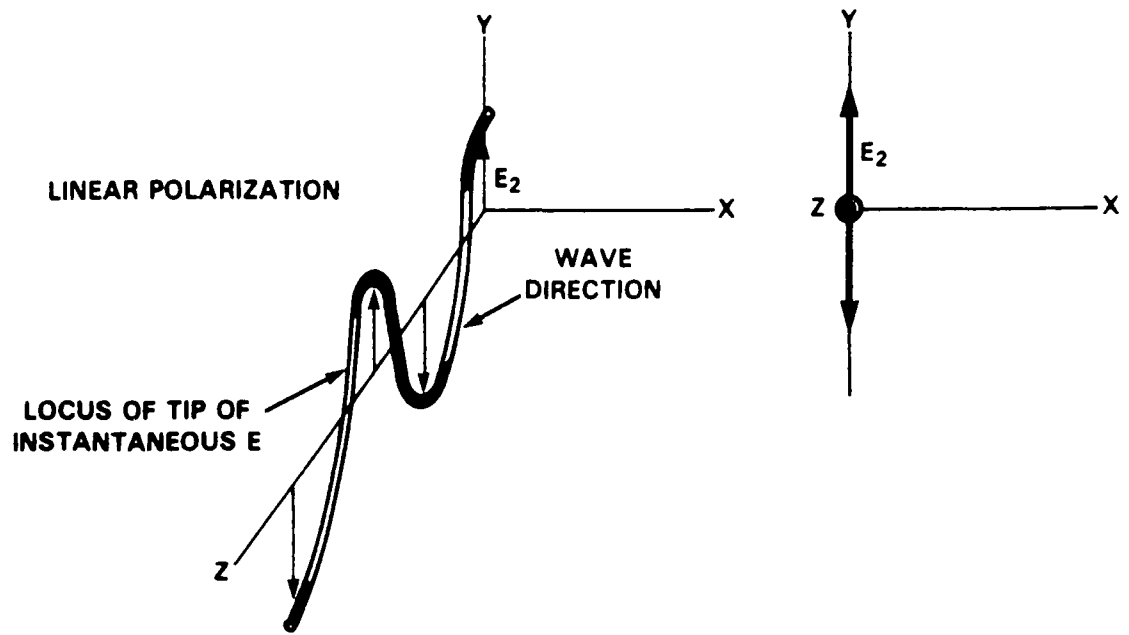

Figure 1-2 Linearly Polarized Wave

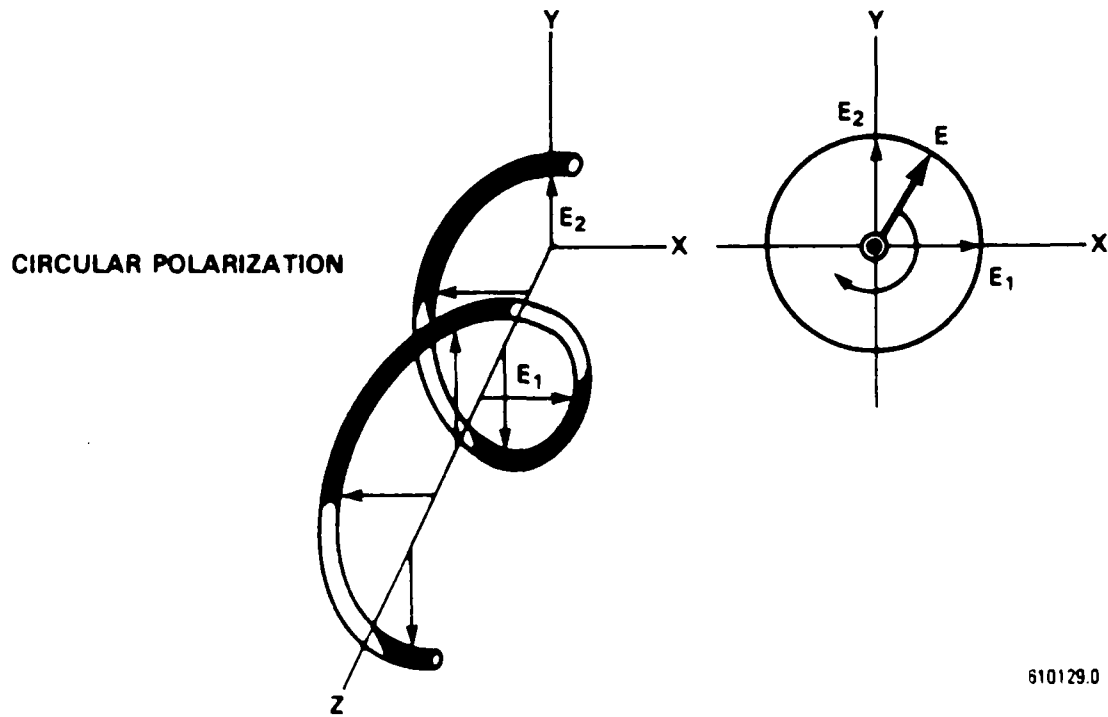

Figure 1-3 Circularly Polarized Wave

610129.0

circularly polarized waves can have either right- or left-hand sense. For a wave to be RHCP, an observer looking in the direction of propagation would see clockwise rotation of the electric field vector in a stationary transverse plane. For LHCP, the rotation would be counter-clockwise [Ref. 1].

1.2.3 Orthogonal Polarizations

The potential for frequency reuse arises because, ideally, linear polarizations that are spatially oriented 90° apart are orthogonal, so that even at the same frequency the waves are totally isolated and their components will not interfere with each other. RHCP and LHCP waves are also orthogonal. Furthermore, antennas also display polarization properties such that an RHCP antenna will (ideally) not respond to a wave emanating from an LHCP antenna and vice versa. Therefore, if two oppositely polarized feeds are installed, the antenna can simultaneously receive two oppositely polarized signals at the same frequency.

For practical cases, the RHCP and LHCP signals are not purely circularly polarized, and it is necessary to describe the degree of non-orthogonality in terms of two additional parameters: the axial ratio and the tilt angle. The axial ratio, AR, is defined as the ratio of the magnitude of the major axis to that of the minor axis ($E_{\text{major}}/E_{\text{minor}}$) of the ellipse traced out by the electric field vector. The tilt angle, T_i , is the angle between the major axis of the ellipse and the x-axis (for a linearly polarized wave, T_i is the angle between the vector and the x-axis). Both the axial ratio and the tilt angle are shown in Figure 1-4 for a wave propagating in a direction normal to the page.

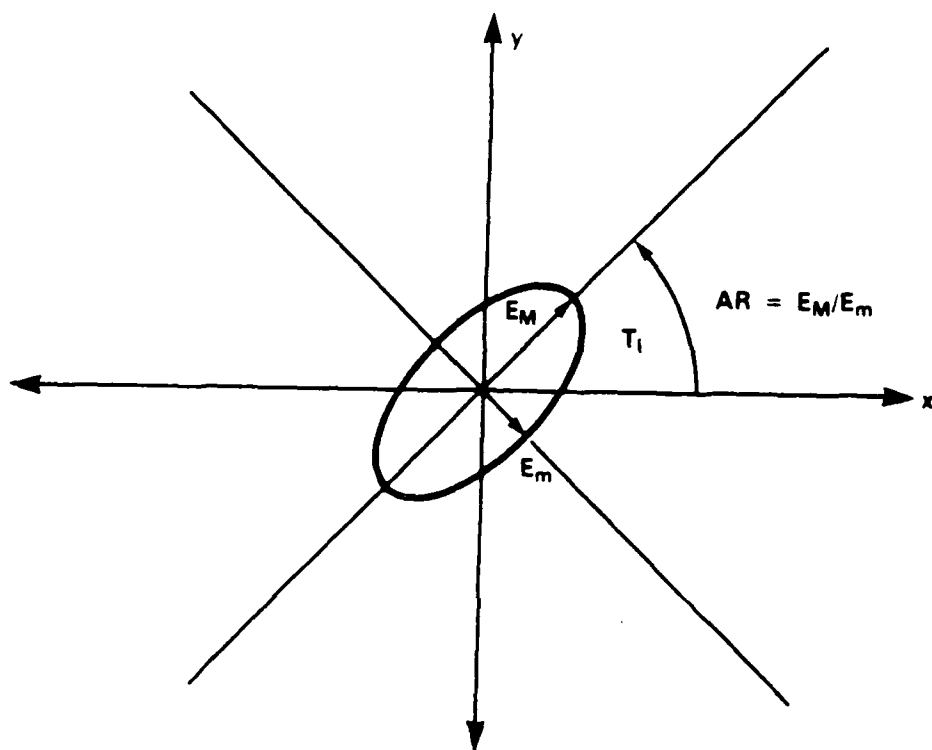
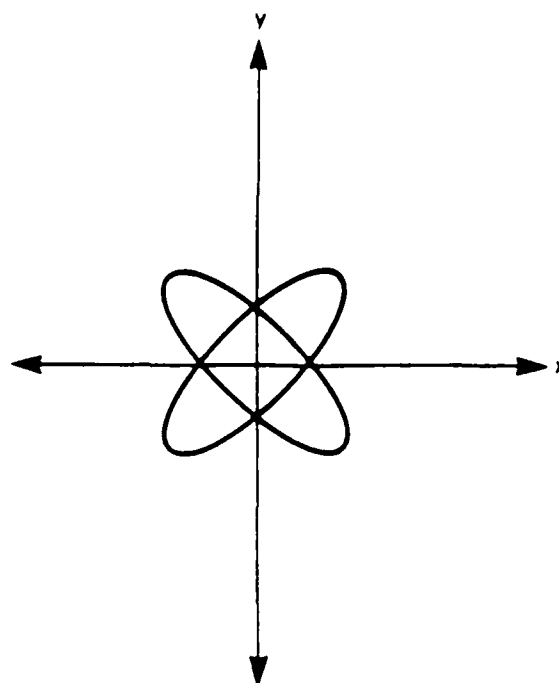
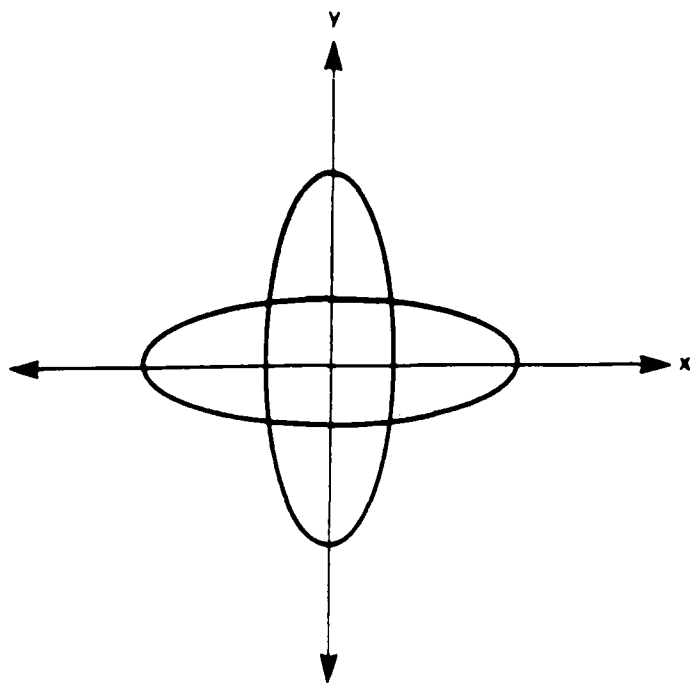

Figure 1-4 Axial Ratio and Tilt Angle of an Elliptically Polarized Wave

If two orthogonal signals are sent, loss of orthogonality can occur for two reasons: (1) the introduction of differential phase shift, and (2) differential path attenuation. Examining the case of two signals with orthogonal linear polarizations, it is apparent that differential attenuation (different magnitudes of attenuation to the u_x and u_y electric field components) will result in two new linearly polarized waves, since $E(z,t)$ only depends on the magnitudes E_x and E_y . Loss of orthogonality will result, however, because the new magnitude values will result in different orientations so that the two signals are no longer spatially oriented 90° apart, i.e., both will have new tilt angles and $T_2 - T_1 \neq 90^\circ$. In a similar manner, differential phase shift will change the relative time-phase between the u_x and u_y components of each signal. This will cause a time phase difference between the u_x and u_y components of each signal different from a multiple of 180° , resulting in two elliptical polarizations. If the two signals are sent along the same path, as on the downlink, then the resulting ellipses will still be orthogonal because in a plane normal to the direction of propagation, the two ellipses drawn out by the electric field vector will have their major axis separated by 90° spatially. For ease of description, a new set of reference vectors are used (as shown in Figure 1-5) to illustrate that orthogonality is maintained despite the rotation of each signal ellipse. If the signals are sent along different paths, the differential phase shift each signal experiences would differ and orthogonality would be lost. The causes of differential phase shift and differential attenuation are discussed in the next section.

1.3 CROSS-COUPLING EFFECTS

Frequency reuse via polarization diversity provides a potential doubling of the available bandwidth within a specified antenna coverage area. It also potentially provides a 3-dB increase in throughput given appropriate link



610128 0

Figure 1-5. Differential Phase Shift of Two Elliptical Polarizations While Maintaining Orthogonality

resources. However, this 3-dB maximum will not be achieved because perfect isolation cannot be maintained between RHCP and LHCP signals. Two channels operating at the same frequency will cross-couple a part of each signal into the other channel and this will reduce the link signal-to-noise ratio for two reasons: (1) the cross-coupled signal components appear as noise,* thus effectively increasing the noise density, and (2) part of the desired signal power is lost due to cross-coupling into the oppositely polarized channel. The resultant loss of signal power and increased noise level will require a reduction in data rate to meet an E_b/N_0 necessary to achieve a specified bit error rate. Without adequate polarization purity of key system components, the loss of E_b/N_0 at high levels of cross-coupling can result in a frequency reuse system with a lower system throughput than a single link without frequency reuse. Thus frequency reuse systems must be developed with sufficient polarization purity (low axial ratios) to provide a net benefit in throughput performance.

The degree of cross-coupling between oppositely polarized signals depends upon the axial ratios of the transmit and receive antennas, transmission media effects such as rain and ice, and earth terminal-to-satellite geometry effects.

In the following, the term, "copolarized signals," refers to signals that are transmitted and received using present DSCS specifications, and the term, "cross-polarized signals," refers to signals that would potentially use the opposite sense of polarization.

*The validity of the assumption that cross-coupled signals appear as noise is considered in Section 3-2.

1.3.1 Axial Ratios

As discussed earlier, the axial ratio of an antenna is the ratio $E_{\text{major}}/E_{\text{minor}}$ of the resulting polarization ellipse. For perfect circular polarization, the axial ratio is unity, and no cross-coupling occurs between copolarized and cross-polarized signals. All real signals, however, are elliptical, and the axial ratio provides a measure of their ellipticity. The higher the axial ratio value, the greater the difference from circular polarization, and hence the higher the degree of cross-coupling.

Cross-coupling is quantified by the end-to-end cross-coupling coefficient C , which is the decibel ratio of cross-polarized to copolarized signal. The amount of isolation between signals equals $(-C)$. The cross-coupling ratio C can be calculated for a given link as follows.

$$C \text{ (dB)} = 20 \text{ Log } \sum_{n=1}^N (AR_n - 1)/(AR_n + 1) \quad (1-4)$$

The AR_n values are the transmit antenna axial ratio (AR_3), the receive antenna axial ratio (AR_1), and the equivalent medium axial ratio (AR_2) that accounts for the effects of rain and ice. AR_2 is calculated using (1-5) and is discussed in Section 1.2.2 [Ref. 2].

$$AR_2 = [(\sqrt{C_m} + 1)/(1 - \sqrt{C_m})] \quad (1-5)$$

where $C_m = C$ (due to medium effects).

Figure 1-6 shows the effect of varying the axial ratios (of the transmit and receive antennas) on the end-to-end cross-coupling coefficient C . It is apparent from the graph that small deviations from unity axial ratios result in large

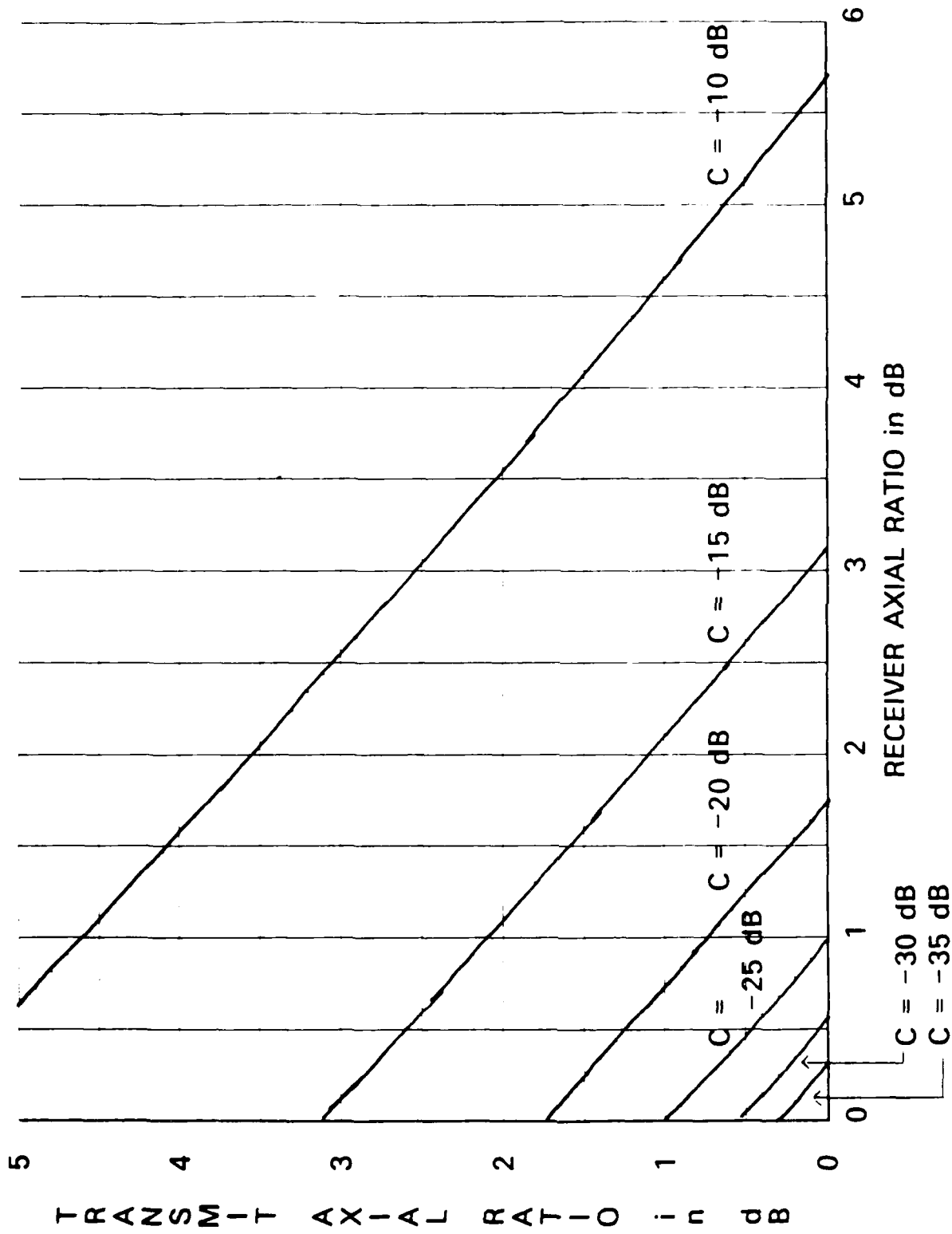

Figure 1-6. Link error-complaining ratio C for various transmitter and receiver axial ratios. No rain correction.

changes in the amount of cross-coupling. Typically, suitable signal quality requires 25 dB of isolation between signals. This would require both the transmit and receive antennas to have axial ratios of 0.5 dB or better.

1.3.2 Depolarization Due to Rain and Ice

As discussed above, the degree of isolation (or cross-coupling) is degraded by medium effects such as rain and ice present in the signal path. Increased cross-coupling occurs because of the non-spherical shape of rain drops that introduce a differential phase shift and differential path attenuation that depolarizes the transmitted signal (i.e., changes the polarization state of the wave). Differential phase shift causes the u_x and u_y components of each of the oppositely circularly polarized waves to no longer be 90° out of phase, thus resulting in two elliptical polarizations. On the downlink, the differential phase shift does not actually affect the orthogonality of the two waves, but as with linear polarizations, it relates the orthogonality to a different set of reference vectors [Ref. 3]. On the uplink, two separate transmission paths are used and orthogonality will be destroyed. Due to the nonspherical nature of raindrops, each of the linear orthogonal components of a circularly polarized wave undergo different amounts of attenuation resulting in elliptical polarizations. This also destroys the orthogonality between RHCP and LHCP signals and obviously introduces a degree of cross-coupling [Ref. 3].

The amount of differential phase shift and attenuation introduced depends on the type of rain, the rain rate, the link geometry, and the frequency band. For terminals in rain region D to achieve a link availability of 0.999, sufficient link margin must be added to accommodate path losses for rain rates up to 20 mm/hr [Ref. 4]. At the DSCS III frequencies, 20 mm/hr rain rates increase cross-coupling effects up to -15 dB and

also can produce up to 4 to 5 dB of signal attenuation. The DSCS system accommodates the rain attenuation by adding up to 5.5 dB of margin to each link. To ensure that existing links can maintain their current link availability, this same worst-case rain rate (20 mm/hr) will also be assumed for a frequency reuse DSCS upgrade system. This rain rate will be modeled as introduction of a -15 dB cross-coupling affect and -100 dB of attenuation, since the attenuation has already been accounted for in the existing link budget.

Later in this report it is shown that cross-coupling coefficients on the order of -15 dB or higher have a severe effect on the link signal-to-noise ratio and, consequently, cause significant reduction in data rate. This reduction would eliminate the potential benefits of frequency reuse. Figure 1-7 shows the resultant link cross-coupling C versus transmit and receive axial ratio, assuming 20 mm/hr rain is present. All values of C are higher than -15 dB unless perfect transmit and receive axial ratios are assumed. The only way possible to compensate for rain induced cross-coupling is to use active polarization tracking and compensation techniques.

1.4 POLARIZATION TRACKING AND COMPENSATION

Polarization compensators are used to introduce a differential phase shift and attenuation in a manner that offsets the medium depolarization [Ref. 5]. Because the depolarization effect is unique to each link due to unique earth terminal-satellite geometry, active polarization compensation can only be performed by earth terminals. Figure 1-8 shows a typical dual frequency access where two earth terminals are transmitting to the same satellite antenna. Since the earth terminals transmit from different locations, the depolarization is unique to each path, and it is impossible to match the satellite antenna to both of the received signals. The depolarization due to geometries is significant

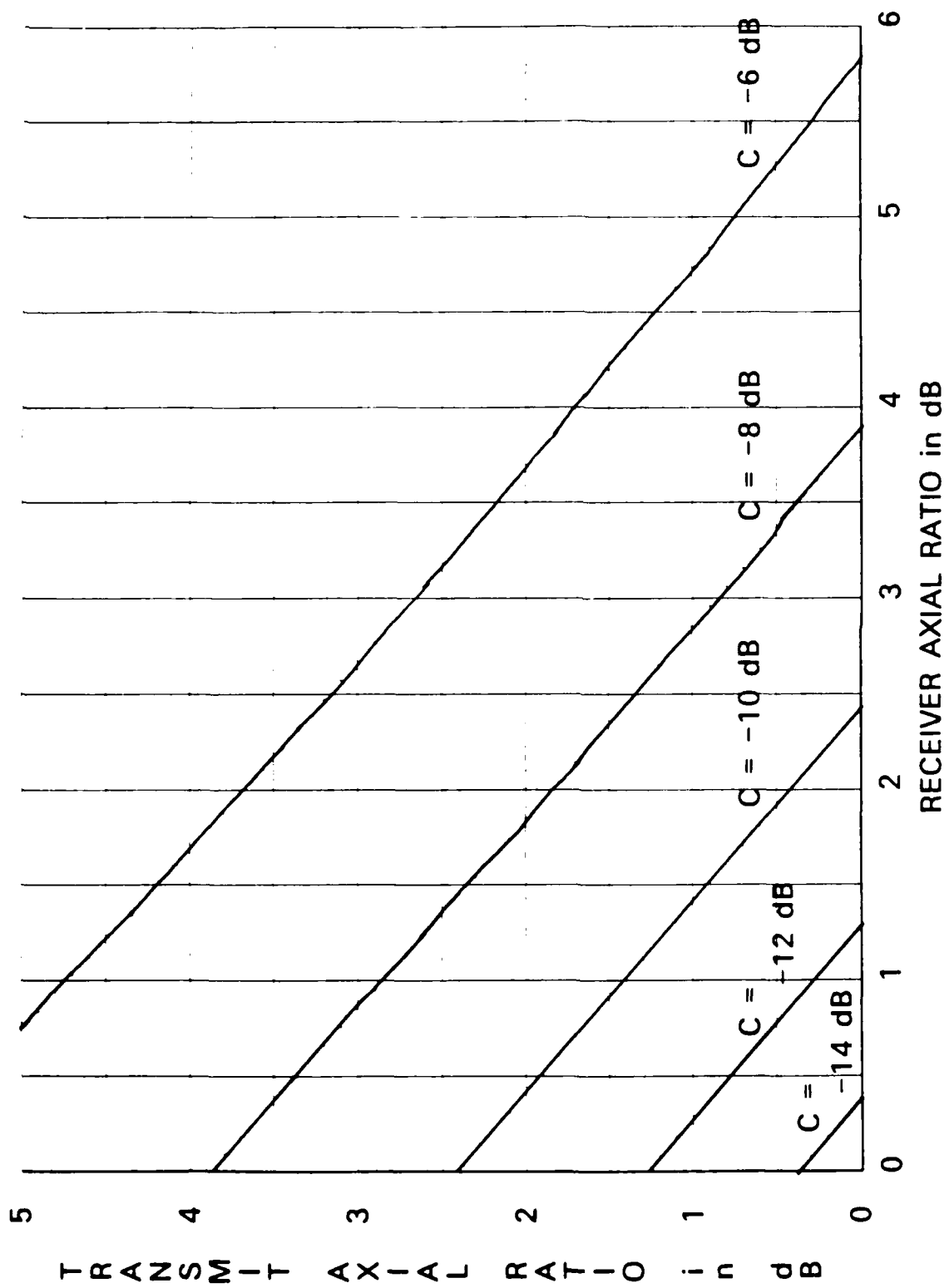
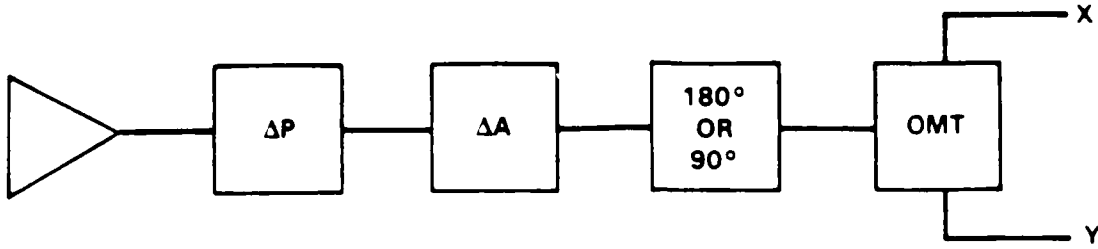

Figure 15. 1-Hz cross-coupling ratio C for various transmit and receive axial ratios. -14-dB gain scenario

not because of an increase in cross-coupling, but because it eliminates the possibility of using a common polarization tracker on the satellite. It is theoretically possible to introduce a polarization tracker in each of the oppositely polarized feeds on each satellite antenna. Weight, space, and cost limitations, however, make this an impractical solution. On the uplink, therefore, it is necessary to use the amount of depolarization determined by downlink measurement to calculate how much the uplink signal must be predistorted to reduce cross-coupling between uplink signals [Ref. 2]. Uplink predistortion is difficult to implement and unfortunately is not as accurate as a downlink polarization tracker because the frequency dependence of rain depolarization prohibits exact calculation of the uplink predistortion required. In addition, the satellite's up and downlink antennas are not orthogonally polarized to the same accuracy as the earth terminal's antenna, because the earth terminal will receive and transmit signals to the satellite using the same antenna, while the satellite will use two different antennas [Ref. 2]. The following sections examine several polarization tracking techniques, and a method for predistorting uplink signals. Figure 1-9 shows the block diagrams for each of the polarization compensation methods described [Ref. 5].

1.4.1 Restoration Method

The restoration method of polarization tracking uses a rotatable differential phase shifter and differential attenuator in the feed assembly of the antennas. The differential phase shifter transforms two arbitrary elliptical polarizations into two nonorthogonal circular polarizations. The differential attenuator is then used to inject orthogonality. It produces excellent wideband polarization recovery, but does this at the expense of a signal loss equal to about half the differential attenuation. The resultant signal loss is equivalent to an increase in noise temperature, i.e., a



1) RESTORATION METHOD

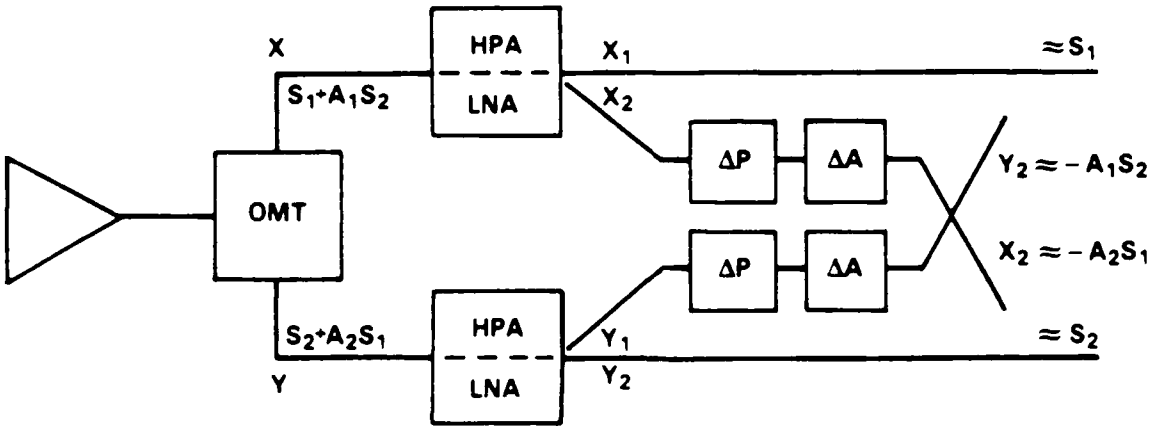

2) CANCELLATION METHOD

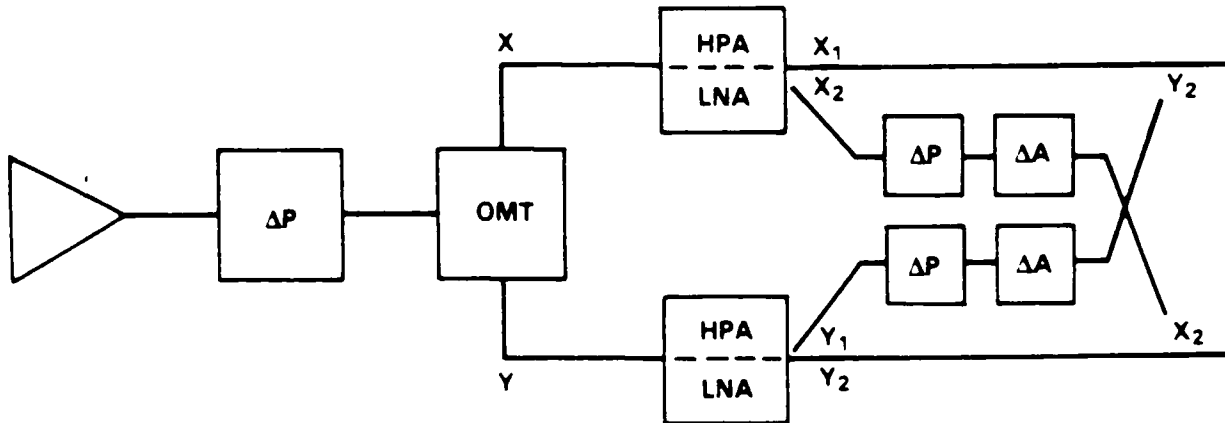

3) HYBRID METHOD

610118 0

Figure 1-4 Methods of Polarization Compensation

reduction in G/T. Because of this, the restoration method is only considered appropriate for receiving stations and is generally not considered for satellite links [Ref. 5]. At lower frequencies (below 5 GHz) the differential attenuation is negligible and differential attenuators are not required. Thus, at frequencies below 5 GHz, nearly orthogonal signals are recovered by differential phase correction methods only and without the introduction of extra thermal noise into the receiving system. The restoration method is sufficient to obtain orthogonality between signals if the axial ratios of the transmit and receive antennas are equal. This is generally not the case but it can guarantee a high degree of isolation between signals. The advantage of this method is its simplicity and that it minimizes the level of attenuation needed to restore orthogonality by first correcting the differential phase shift [Ref. 6].

1.4.2 Cancellation Method

The cancellation method uses cross-coupling to generate the proper phase and amplitude to cancel out the interfering components in each signal. Two pilot signals are required with this method, one for each signal. These produce four error quantities (two in-phase and two quadrature-phase) that are used to determine the necessary levels of attenuation and phase shift that must be cancelled out for each signal. The cross-coupling network then uses a differential phase shifter and attenuator to generate cancellation signals as shown in Figure 1-9. To understand how this is achieved, define the received pilot signals to be x and y for transmitted pilot signals S_1 and S_2 where:

$$\begin{aligned} x &= S_1 + a_1 S_2 \\ \text{and} & \\ y &= S_2 + a_2 S_1 \end{aligned} \tag{1-6}$$

where

$$a_1 = a'_1 \exp(jp_1)$$

and

$$a_2 = a'_2 \exp(jp_2).$$

A 3-dB coupler is used to split x into two components x_1 and x_2 . One of these components, x_2 , is differentially phase shifted by p_2 and attenuated by a'_2 . Therefore,

$$x_2 = a_2 S_1 + a_1 a_2 S_2 \quad (1-7)$$

For $a_1, a_2 \ll 1$ this approximates $a_2 S_1$. The S_2 component then has its polarization changed by 180° so that $x_2 = -a_2 S_1$. The other signal y experiences the same process so that

$$y_1 = S_2 + a_2 S_1$$

and

$$y_2 = -a_1 S_2$$

(1-8)

y_1 and x_2 are then combined as are x_1 and y_2 to give

$$y'_1 = y_1 + x_2 = S_2$$

(1-9)

$$x'_1 = x_1 + y_2 = S_1$$

at the outputs of the compensator. The pilot signals experience the same differential phase shift and differential attenuation as the information signals. The four error quantities are used to control the two differential attenuator and two differential phase shifters shown in Figure 1-9, so that both the phase and attenuation terms of a_1 and a_2 can be duplicated. The entire signal is then put through the differential attenuators and phase shifters so that both the

pilot signal and the information signal will be corrected. Good performance cannot be expected over the wideband because it is difficult to match the phase and amplitude characteristics between two high-power amplifiers and low-noise amplifiers [Ref. 5]. Experimental cancellation networks operating at 12 GHz have been developed. Results show that this method improved -20 dB of cross-coupling to approximately -40 dB [Ref. 7].

1.4.3 Hybrid Method

This method is a combination of the above two methods. It uses a phase shifter to perform most of the compensation, and a cross-coupling network to cancel the differential attenuation. This is the most effective of the three methods because (1) low loss phase shifters are available and (2) the bandwidth limitations are not critical because only a small amount of correction is required in the cross-coupling circuit [Ref. 5].

1.4.4 Types of Predistortion Network

Since the satellite cannot utilize a polarization tracker for reasons mentioned earlier, predistortion of the uplink signals may be necessary when rain depolarization is present. Two separate methods have been previously proposed [Ref. 8]. The first is a closed loop system that uses an uplink beacon to characterize the medium depolarization. This method is not preferred for DSCS because it would require every ground station to transmit two separate pilot signals for phase and attenuation correction. Since the DSCS has so many different ground stations, this would unnecessarily waste communications bandwidth. The second type of predistortion network uses a known correlation between depolarizations at the uplink and downlink frequencies to derive up- and downlink control signals from only a downlink beacon. This correlation must be

established by utilizing rain data at the given frequencies and using an algorithm to maximize the isolation on the uplink. The known correlation is used to create a control network that determines the angles of the polarizers for the uplink from the algorithm and the known positions of the polarizers on the downlink. This method is probably the best for the DSCS. To implement it will require more information on rain depolarization at DSCS uplink and downlink frequencies and the development of an algorithm that precompensates uplink propagation effects [Ref. 8].

1.5 CURRENT SYSTEMS USING CROSS-POLARIZATION

The INTELSAT V satellite system is a commercial system operating at 6/4 GHz that consists of large, stationary earth terminals and a number of satellites in the space segment. Currently INTELSAT V implements frequency reuse via orthogonal circular polarization. Although the system could have been designed to use orthogonal linear polarization, circular polarization was chosen instead because an effect called Faraday Rotation, which can rotate the electric field direction of linearly polarized signals. Faraday rotation is caused by ionization of electrons in the upper atmosphere.* This rotation causes cross-coupling at the receive antenna if the antenna is adjusted to receive a specific linear polarization and actually receives a different polarization. Experimental results later showed that the projected effects of Faraday rotation were less severe than expected and linear polarization could have been used. Satellite Business Systems (SBS) is

*This effect is increased dramatically in a nuclear-perturbed environment, hence DSCS will maintain its current use of circularly polarized signals.

currently planning a system that implements frequency reuse with linear polarization. This system will operate at 14/11 GHz where the effects of Faraday rotation are known to be negligible.

The INTELSAT V system design has specified very low axial ratios for spacecraft and ground terminal antennas; 0.75 dB and 0.50 dB, respectively. Using Figure 1-6, these INTELSAT V axial ratio specifications indicate that less than -28 dB of cross-coupling is achieved in clear weather on a given link. In 20 mm/hr rain, C increases to -12 dB, but the INTELSAT V uses active polarization compensation and 26 dB of isolation is obtained. As shown later, current DSCS space and ground segment antenna axial ratios are much greater than the INTELSAT V and result in significantly worse cross-coupling effects.

Another important distinction between the two systems is that INTELSAT operates at 6/4 GHz and DSCS III operates at 8/7 GHz [Ref. 8]. At lower frequencies, the effects of differential attenuation are not as great. Since differential attenuation at 6/4 GHz is small, the INTELSAT V system does not have to correct for differential attenuation with its active polarization compensators. Therefore, INTELSAT V uses a lossless version of the hybrid method, whereas the differential attenuators will probably be necessary for the DSCS III. The difference in operating frequency will also eliminate the possibility of using the predistortion algorithm developed for the INTELSAT V with the DSCS III.

Figure 1-10 shows the up- and downlink compensated and uncompensated isolation for an experimental simulation of the INTELSAT V link performed with an INTELSAT IVa satellite [Ref. 8]. The figure shows that the compensated isolation remained above 25 dB even in severe rain storms.

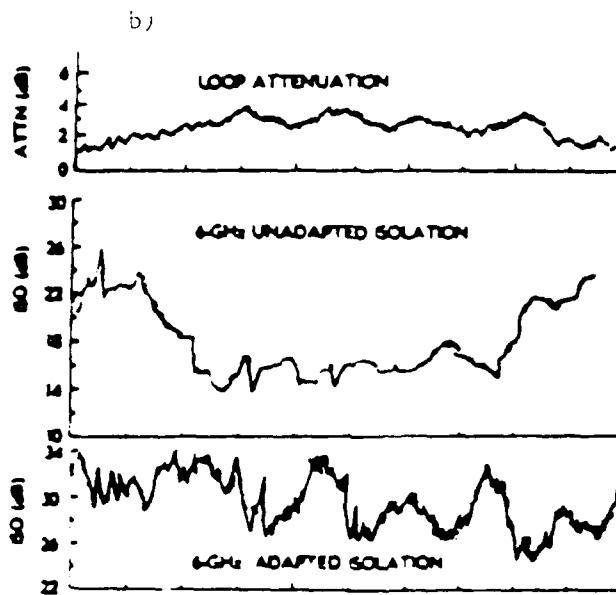
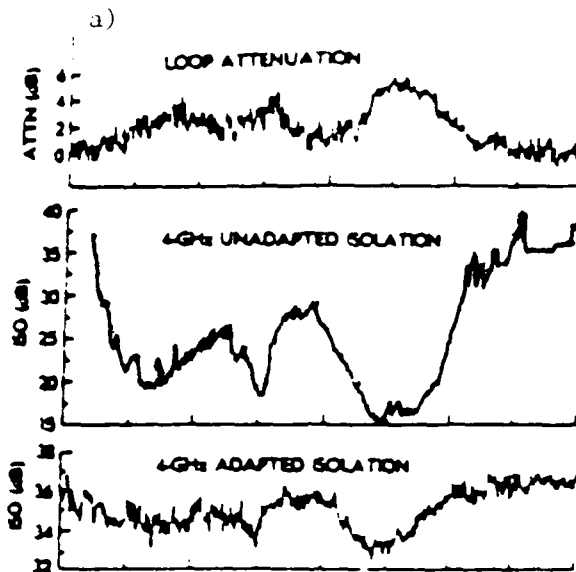

Figure 1-10 Simulated INTELSAT V Dual Frequency Performance in 20mm/hr Rain
 a) Downlink Results
 b) Uplink Results

CHAPTER 2 DSCS SYSTEM

2.1 CURRENT DSCS SYSTEM

2.1.1 Space Segment

Figure 2-1 shows a functional block diagram of the DSCS III satellite. The satellite consists of two 40-W channels (channels 1 and 2) and four 10-W channels (channels 3 through 6). For satellites up to and including B7, the total usable bandwidth is 375 MHz. Starting with satellite B8, improved elliptical filters will be used that will increase the usable bandwidth to 405 MHz. The extra 30 MHz of bandwidth is achieved by reducing three 25-MHz guardbands to 15-MHz each. The bandwidths of the six DSCS III channels for the old and new frequency plan are shown in Table 2-1. Currently, the DSCS system uses RHCP for the uplink and LHCP for the downlink.

The satellite uses a variety of transmit and receive antennas. The receive antennas consist of a 61-element multibeam receive antenna (MBR) and two earth coverage horn (ECH) antennas (E1R and E2R). The transmit antennas consist of two 19-element multibeam antennas (M1X and M2X), two ECHs (E1X and E2X) and one gimballed dish antenna (GDA). Table 2-2 shows the antenna and channel connectivity scheme for the DSCS III satellite. Each channel can only be connected to one transmit or receive antenna simultaneously. The axial ratios of the satellite antennas are given in Table 2-3. The axial ratios range from a worst case of 5 dB for the MBR in an earth coverage mode to the best case of 2.5 dB for the transmit and receive ECH.

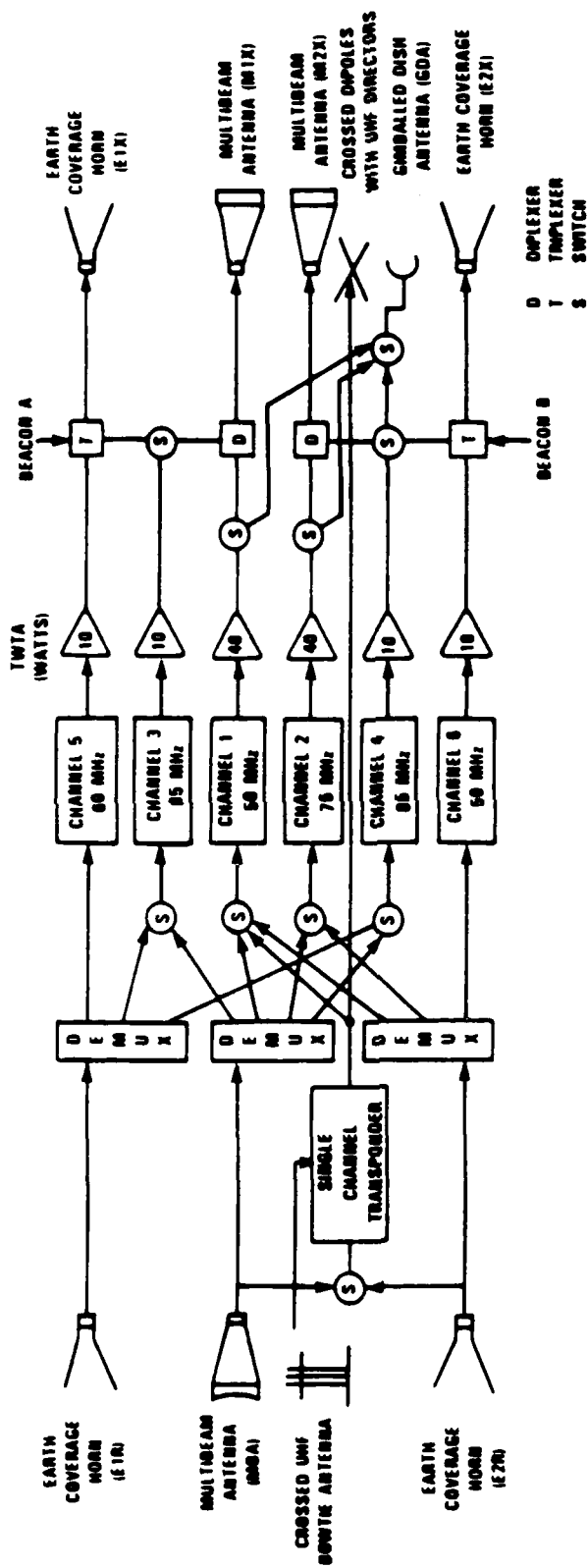

602210 0

Figure 2-1. DSCS III Transponder Channel and Antenna Connectivity Diagram

Table 2-1. Bandwidth of DSCS III Channels

CHANNEL	BANDWIDTH (MHz)	
	A1 THROUGH B7	B8 AND BEYOND
1	60	50
2	60	75
3	85	85
4	60	85
5	60	60
6	50	50

610124 0

Table 2-2. DSCS III Antenna Connectivity

ANTENNA	CHANNEL					
	1	2	3	4	5	6
RECEIVE						
MBR	•	•	•	•		
E1R			•	•	•	
E2R	•	•				•
TRANSMIT						
M1X	•		•			
M2X		•		•		
E1X			•		•	
E2X				•		
GDA	•	•		•		•

610125 0

Table 2-3. Specification Values for Axial Ratios for Current DSCS Satellite Antennas

ANTENNA	AXIAL RATIO (dB)
EARTH COVERAGE HORN	2.5
MBR EARTH COVERAGE MODE	5.0
NARROW COVERAGE MODE	3.0
MBX EARTH COVERAGE MODE	4.5
NARROW COVERAGE MODE	4.0
GDA	3.0

610126.0

2.1.2 Earth Terminals

The DSCS system uses a variety of earth terminals. Terminals range from mobile 2.75-foot terminals used by aircrafts (AN/ASC-24) to large 60-foot hub terminals (AN/FSC-78). Because of the large variation in antenna sizes, the transmit EIRP and receive G/T of the terminals have a large range in values. EIRPs range from a low of 66.0 dBW for the 6-foot LST-8000 to a high of 94.0 dBW for the 60-foot AN/FSC-78. Table 2-4 summarizes the characteristics of the DSCS earth terminals and shows the specified axial ratios values for the terminals. Available measured values of axial ratios are shown in parentheses; the specified values range from a low 1.5 dB to a high of 3 dB. The best measured value of axial ratio is 0.9 dB.

Table 2-5 shows the achievable cross-polarization isolation per link (uplink or downlink) for various combinations of DSCS satellite and earth terminal antennas axial ratios using equation (1-1). As is shown in Table 2-5, the current DSCS system antennas will only provide between 7 to 14 dB of cross-polarization isolation for each uplink or downlink path.

2.2 UPGRADED DSCS III SATELLITE

The DSCS Research, Development, Test, and Evaluation (RDT&E) Working Group developed a potential candidate for an upgraded DSCS III satellite. A block diagram of this potential upgraded satellite is shown in Figure 2-2. The satellite would weigh 3400 pounds and use 1900 W. While there are many differences between this candidate upgrade and the current DSCS III satellite, the focus of this discussion is the addition of a cross-polarized channel. In this report, two cross-polarized channel implementations will be analyzed in detail. The first technique uses a wideband cross-polarized channel (75 to 100 MHz) and the second technique uses a narrowband cross-polarized channel (15 to 25 MHz).

Table 2-4. Earth Terminal Characteristics

	ANT. SIZE (FT)	EIRP (dBW)	G/T (dB/K)	RCV. ANT. GAIN (dBI)	NOISE TEMP. (K)	AXIAL RATIO* (dB)
FSC-78	60	94.0	39.0	59.9	125	2 (2)
MSC-60	60					2 (2)
GSC-39	38	92.0	34.0	55.5	140	2 (1.4)
GSC-52	38	91.0	33.0	55.5	178	2 (1.4)
MSC-61	60					2 (1.4)
GSC-49	20	81.0	26.0	50.6	288	3
	8	73.0	18.0	42.6	288	3 (0.9)
TSC-54	18	88.0	26.0	49.1	204	
TSC-86	20	79.0	26.0	50.6	288	3
	8	73.0	18.0	42.6	288	1.5 (0.9)
TSC-90	6.33					
TSC-85A	20	78.4	26.0	50.6	288	3
	8	70.0	18.0	42.6	288	1.5 (0.9)
TSC-93A	8	70.0	18.0	42.6	288	1.5 (0.9)
TSC-94A	8	70.4	18.0	42.6	288	1.5 (0.9)
TSC-100A	20	80.5	26.0	50.6	288	3
	8	75.5	18.0	42.6	288	1.5 (0.9)
SC-1A	6	65.7	17.5	39.5	159	2
SC-1B	18	74.0	26.0	49.1	204	2
SC-3	18	73.4	26.0	49.1	204	2
	8	68.5	17.5	42.1	288	2
SC-4	35	90.0	31.0	54.9	246	2
ASC-24	2.75	70.0	6.5	31.6	325	
WSC-6	6	70.0	14.0	39.1	325	
LST-8000	6	66.0	17.1	40.8	235	2

*Numbers in parenthesis are measured values.

Table 2-5. Cross-Polarization Isolation for DSCS Antenna

SATELLITE AR (dB)	EARTH TERMINAL AR (dB)			
	3.0	2.0	1.5	0.9
5.0	6.91	8.07	8.72	9.58
4.5	7.44	8.68	9.39	10.31
4.0	8.02	9.35	10.11	11.12
3.0	9.32	10.88	11.80	13.04
2.5	10.06	11.78	12.80	14.21

610123.0

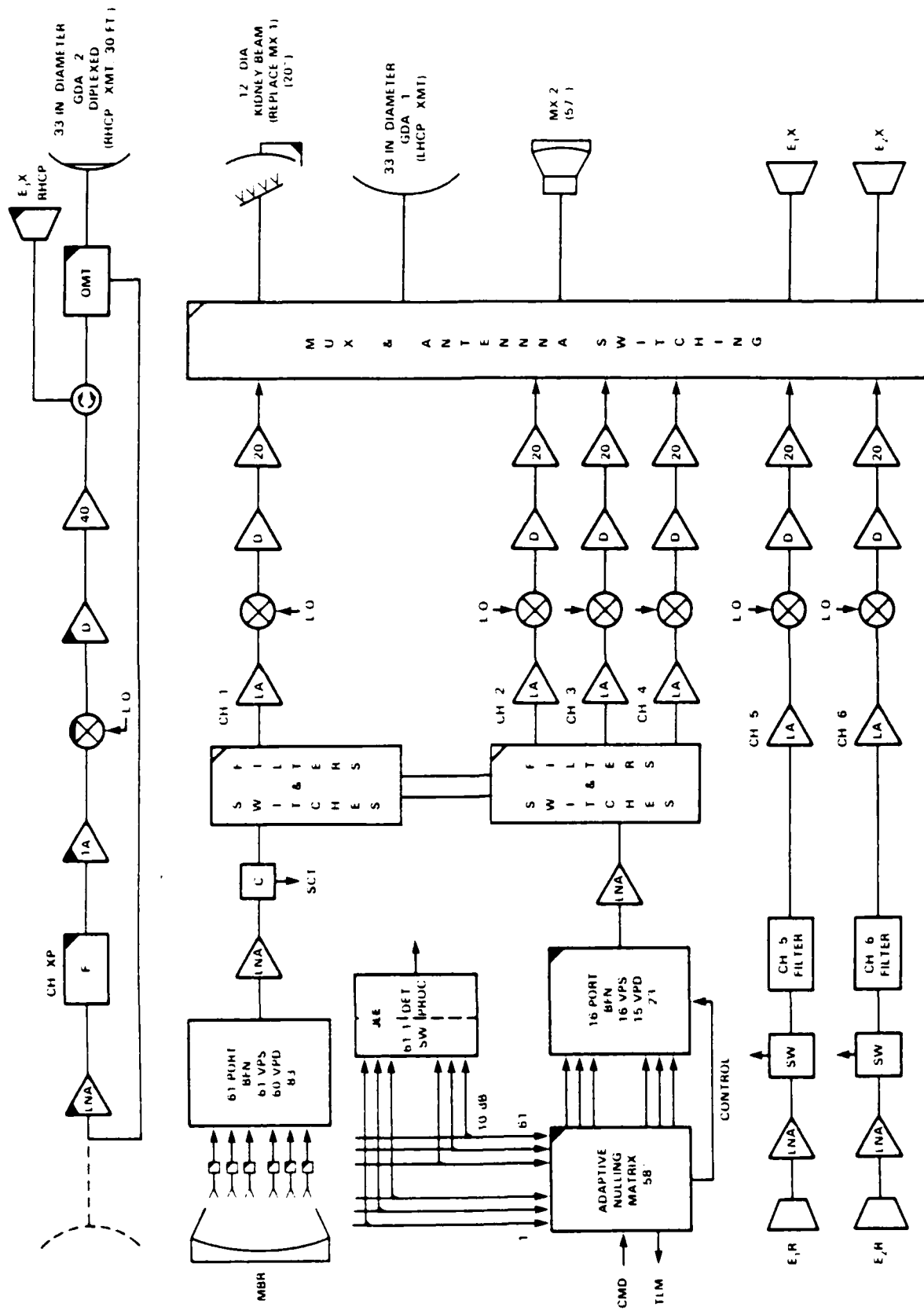

FIGURE 2-2. DSCS RPT&E STRAWMAN SIF DESIGN

2.2.1 Wideband Cross-Polarized Channel

The wideband cross-polarized channel envisioned by the DSCS RDT&E Working Group was a 75- to 100-MHz channel and a 40-W travelling wave tube amplifier (TWTA) with a linearizer to increase usable power for frequency division multiple access (FDMA) signals. The antenna would be a diplexed theater coverage GDA (2.5° beamwidth). In addition, the cross-polarized channel could also use an ECH for the downlink. The cross-polarized channel would be used by the GMF community. Moving the GMF to the cross-polarized channel would allow ECCM users to use both channels 1 and 2. The frequencies used by the cross-polarized channel users would be either the same as for channels 1 and 2, channels 3 and 4, or channels 5 and 6.

2.2.2 Narrowband Cross-Polarized Channel

As shown later in Chapter 4, use of a wideband cross-polarized channel would require major upgrades to the satellite and almost all earth terminal antennas. Based upon these results, a second concept was developed using a narrowband (15 to 25 MHz) cross-polarized channel placed opposite a 25-MHz guardband thus benefiting from both frequency and cross-polarization isolation. The channel would use a 40-W TWTA with a linearizer and use ECH antennas for both up- and downlinks. This channel would potentially support the WHCA, TACIES, and the JCS Contingency users.

Figure 2-3 shows the frequency plan for the DSCS III satellite. The satellite contains two 25-MHz guardbands. However, since the guardband between channels 4 and 5 is used by the satellite beacons, a minimum impact alternative would be to place the cross-polarized channel in the guardband between channels 1 and 6 on the uplink (7950 to 7975 MHz) and channels 5 and 6 on the downlink (7675 to 7700 MHz). Use of these frequency bands would require a third onboard frequency

translation subsystem to provide a 275 MHz offset for the cross-polarized channel. (Currently, channel 6 is frequency translated 200 MHz, while channels 1 through 5 have a frequency translation of 725 MHz.)

Figure 2-4 shows the filter characteristics for channels 1 and 6 and for the cross-polarized channel assuming 15-MHz and 25-MHz channel bandwidths. The curves show that the channel filters only attenuate signals by 2 dB for the first 5 MHz into the guardband. The attenuation then increases more rapidly with frequency until the attenuation reaches 40 to 45 dB by the start of the next channel. If the bandwidth of the cross-polarized channel is 25 MHz, then the channel filters will on the average provide approximately 7.6 dB of additional isolation (e.g., they will attenuate the cross-polarized noise received by the channel by 7.6 dB, thereby effectively increasing the cross-polarization isolation by 7.6 dB.) For a 15-MHz-wide cross-polarized channel, the channel filters will provide approximately 15.4 dB of additional isolation.

The next chapter discusses the methodology used to determine the impact the use of a cross-polarized channel would have on the DSCS system.

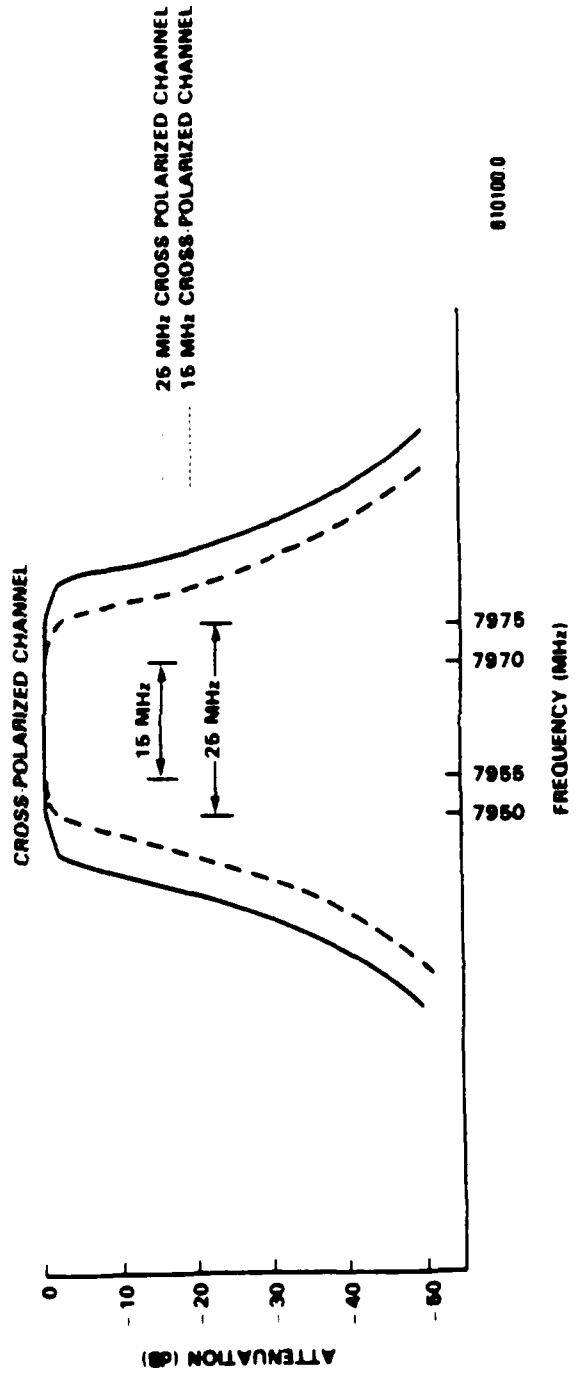
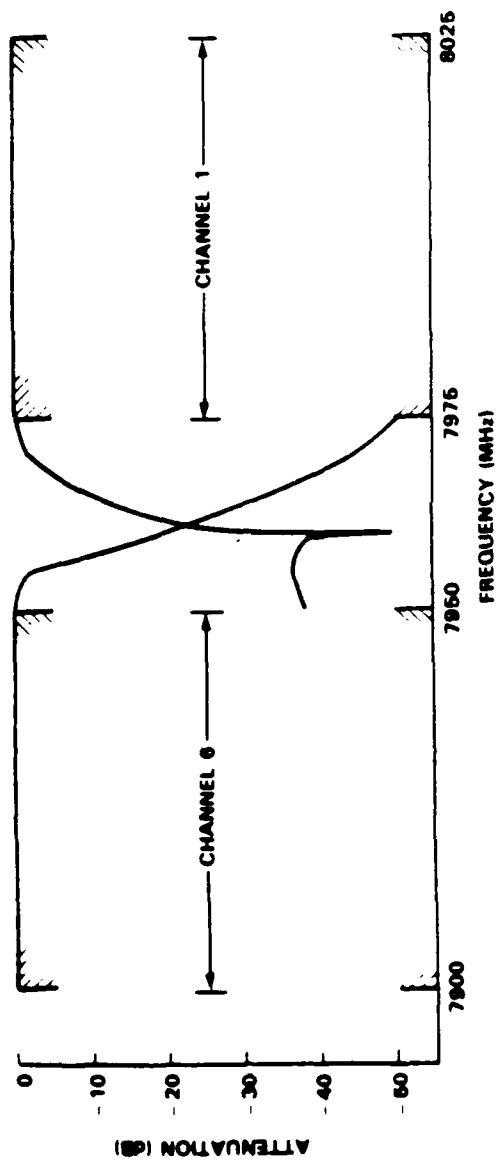

Figure 2-4. Channel Filter Characteristics for D3C3 III

CHAPTER 3
METHODOLOGY

3.1 DETERMINATION OF LINK SIGNAL-TO-NOISE RATIO (SNR)
(E_b/N_o) [REF. 2]

In this section the effects of cross-polarization signal interference on link signal-to-noise ratio (E_b/N_o) will be calculated. In determining the E_b/N_o on a dual-polarized link, primary considerations are the thermal noise density level (N_o) and the amount of cross-coupling between oppositely polarized signals. Several assumptions are made in this development, namely:

- Signal bandwidth overlap
- Signals are statistically independent
- Only the desired signal, a single cross-polarization component, and thermal noise exist in the channel.

Let P_1 be the power transmitted in channel 1 (the copolarized channel) and P_2 be the power transmitted in the cross-polarized channel. Due to cross-coupling effects, the SNR in channel 1 is given as:

$$\frac{S}{N} = \frac{P_1(1-C)}{P_2C + N_oB} \quad (3-1)$$

where

(1-C) = the fraction of channel 1 transmit power lost due to cross-coupling effects,

P_2C = the interference power coupled into channel 1 from the cross-polarized channel,

and

N_oB represents the thermal noise level in channel 1.

Letting $S = \text{received signal} = P_1(1-C)$ yields

$$\frac{S}{N} = \frac{S}{P_2 C + N_o B} = \frac{(S/N_o B)}{1 + (C/(1-C)) (P_2/P_1) (S/N_o B)} \quad (3-2)$$

If the data rate equals the filter bandwidth B , then $E_b/N_o = S/N$. Therefore, equation (3-2) can be rewritten as

$$E_b/N_o = \frac{(E_b/N_o)'}{1 + (C/(1-C)) (P_2/P_1) (E_b/N_o)} \quad (3-3)$$

where $(E_b/N_o)'$ is the required E_b/N_o for the link in the absence of cross-polarized interference.

The cross-coupling coefficient, C , depends on three factors and is computed by

$$C = 20 \text{ Log} \left(\sum_{n=1}^3 \frac{AR_n - 1}{AR_n + 1} \right) \quad (3-4)$$

where $AR_1 =$ the axial ratio of the transmit antenna

$AR_2 =$ the equivalent axial ratio of the cross-coupling caused by the rain

and

$AR_3 =$ the axial ratio of the receive antenna.

As discussed in Section 1.2.2, it is known that in rain region D, 0.1 percent of the time rain will cause a cross-coupling coefficient C of -15 dB. To calculate an equivalent rain-induced axial ratio for a given C , the following equation is used:

$$AR = (10^{C/20} + 1) / (1 - 10^{C/20}) \quad (3-5)$$

where C is in dB. Using $C = -15$ dB in equation (3-5) yields $AR_2 = 3.6$ dB; an equivalent rain-induced axial ratio that will not be exceeded for more than 0.1 percent on a yearly basis in rain region D.

Figures 3-1 and 3-2 show plots of E_b/N_o versus the ratio of cross-polarized transmit EIRP to copolarized transmit EIRP (P_2/P_1) for selected values of axial ratio and rain depolarization. The values of rain depolarization used are for the no rain case ($C_2 = -100$ dB, $AR_2 = 1.0$) and the 20 mm/hr rain rate case ($C_2 = -15$ dB and $AR_2 = 1.43$). The axial ratio values were chosen to show the best earth terminals communicating with the GDA. Results shown in Figures 3-1 and 3-2 are for three cases corresponding to a system without polarization trackers and to a system that uses polarization trackers that increase the polarization isolation by 10 dB and 20 dB. Figures 3-1 and 3-2 show that, even without rain, a loss of 1 dB in E_b/N_o is experienced at equal power ratios (unless polarization compensation is used), and that E_b/N_o falls off from these levels quickly if unequal signal powers are used. The curves also show that if polarization trackers can provide 20-dB isolation, the E_b/N_o remains constant regardless of the power ratios. The same result is achieved even if the effects of rain are included (see Figure 3-2) provided the polarization trackers provide at least 20 dB of isolation improvement.

Tables 3-1 and 3-2 list the E_b/N_o values for a broader range of axial ratio values. The $AR_{SAT} = 5$ dB corresponds to the multiple beam antenna (MBA), $AR_{SAT} = 3$ dB is the GDA, and $AR_{SAT} = 0.5$ dB corresponds to an upgraded antenna.

The link E_b/N_o calculations performed in this section use a simple, but accurate, technique to determine dual-polarized system performance. These calculations indicate that the important factors in realizing such a system are the axial

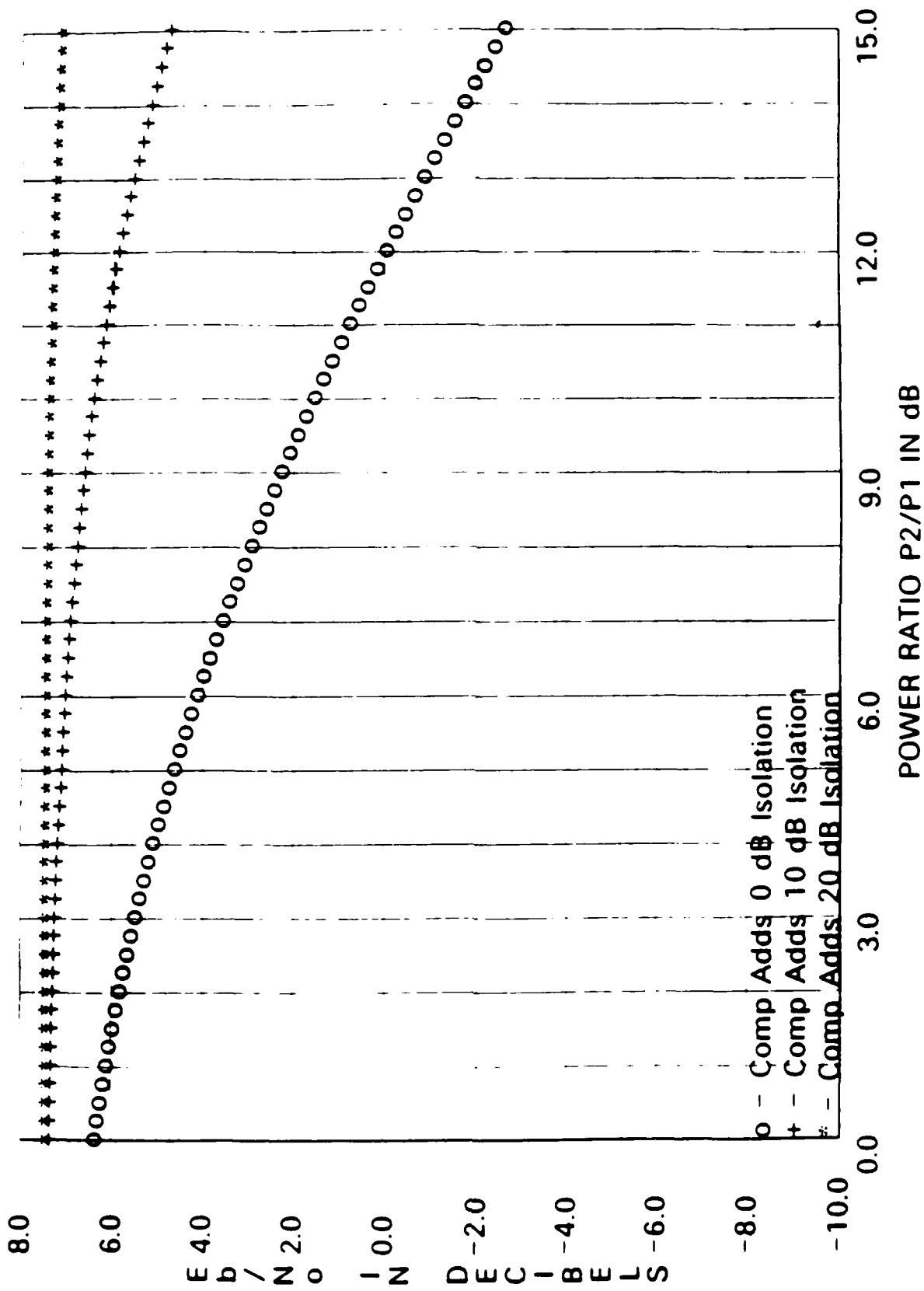

Figure 3-1. Link E_b/N_0 vs. Ratio of Cross-Polarized Transmit EIRP to Copolarized Transmit EIRP (No Rain Case)

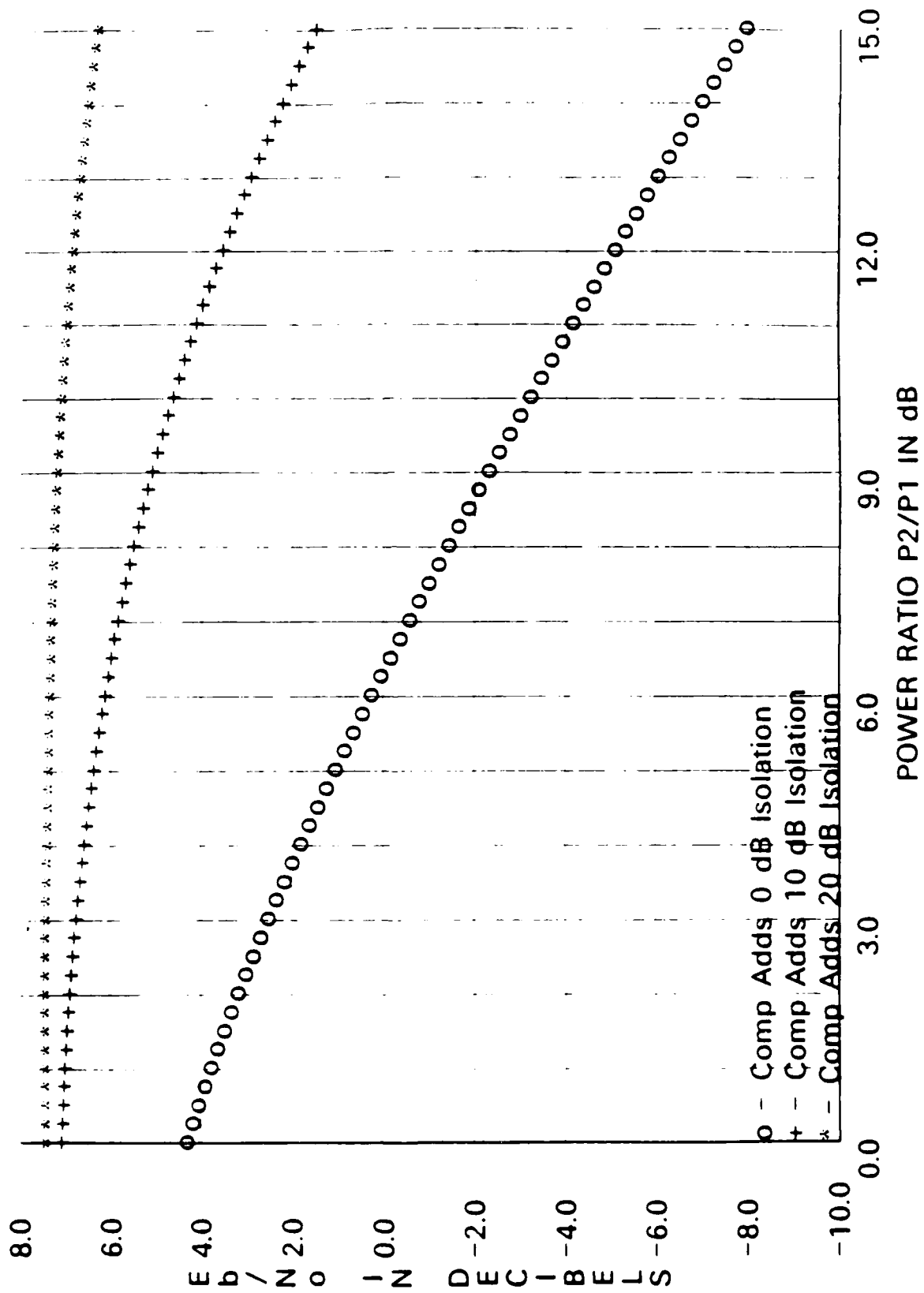

Figure 3-2. Link E_b/N_0 vs. Ratio of Cross-Polarized transmit ERP to Copolarized Transmit ERP (With Rain)

Table 3-1. Link E_b/N_0 Due to Cross-polarization Noise
 (Without Rain-Required $E_b/N_0 = 7.5$ dB)

P2/P1 RATIO (dB)	ARSAT = 5 dB (MBR)		ARSAT = 3 dB (GDA)		ARSAT = 0.5 dB	
	ARET (dB)	3.0	ARET (dB)	3.0	ARET (dB)	3.0
0	5.2	3.6	6.4	5.1	7.3	6.6
5	2.4	0.1	4.6	2.2	7.0	5.1
10	-1.5	-4.4	1.5	-1.8	6.1	2.3
15	-6.1	-9.2	-2.6	-6.4	4.2	-1.7

Table 3-2. Link E_b/N_0 Due to Cross-polarization Noise
(With Rain-Required $E_b/N_0 = 7.5$ dB)

P2/PI RATIO (dB)	RAIN COMP. (dB)	ARSAT = 5 dB (MBR)		ARSAT = 3 dB (GDA)		ARSAT = 0.5 dB	
		ARET (dB)	3.0	ARET (dB)	3.0	ARET (dB)	3.0
0	0	2.8	0.8	4.3	2.6	6.0	4.6
	10	6.9	6.6	7.1	6.9	7.3	7.2
	20	7.4	7.4	7.5	7.4	7.5	7.5
5	0	-1.1	-3.5	1.1	-1.3	3.9	1.5
	10	5.8	5.1	6.4	5.8	7.0	6.5
	20	7.3	7.2	7.4	7.3	7.4	7.4
10	0	-5.7	-8.3	-3.2	-5.9	0.5	-2.6
	10	3.5	2.3	4.7	3.4	6.1	4.9
	20	6.9	6.6	7.1	6.9	7.3	7.2
15	0	-10.5	-13.2	-7.9	-10.8	-3.9	-7.4
	10	-0.1	-1.7	1.6	-0.2	4.1	2.0
	20	5.8	5.2	6.4	5.8	7.0	6.5

ratio values, the signal power ratio, and the amount of rain compensation. The results show how each of these factors affect the link E_b/N_o , and indicate that the E_b/N_o is very sensitive to each factor. A number of assumptions are made in these calculations, such as the bandwidth equals the data rate and that only two signals are being transmitted. Section 3.2 will relax these assumptions and calculate the end-to-end link results for the actual DSCS III system configuration.

3.2 CALCULATION OF SYSTEM THROUGHPUT

In this section, equations will be developed for calculating the end-to-end throughput for a link in a system utilizing dual-polarized signals. In this analysis, the interference caused by the cross-coupling will be treated as additional thermal noise. This assumption will greatly simplify calculations, and will add only a very slight error (less than 1 dB and in most cases less than 0.5 dB) in the results.

The curves in Figure 3-3 are from an analysis performed by Rosenbaum [Ref. 9]. E_b/N_o losses for PSK signals are calculated assuming interfering PSK signals in the presence of Gaussian noise. The curves in Figure 3-3 are graphs of bit error rates (BER) versus carrier-to-noise ratios (CNRs) for two carrier-to-interference ratios (CIRs), namely CIR = 18 dB and CIR = 8 dB. The number N in the curves is number of interferers, with $N = \infty$ being the case where the interferers are treated as Gaussian noise. For the CNR of interest in this study (CNR = 6 to 7.5 dB) and for high CIR (Figure 3-3a), assuming the interferers are Gaussian noise would make the results pessimistic by less than 0.5 dB. For low CIR (Figure 3-3b), considering the interferers as Gaussian noise gives results that are pessimistic by less than 1 dB. Because typical DSCS operations use a wide variety of data rates,

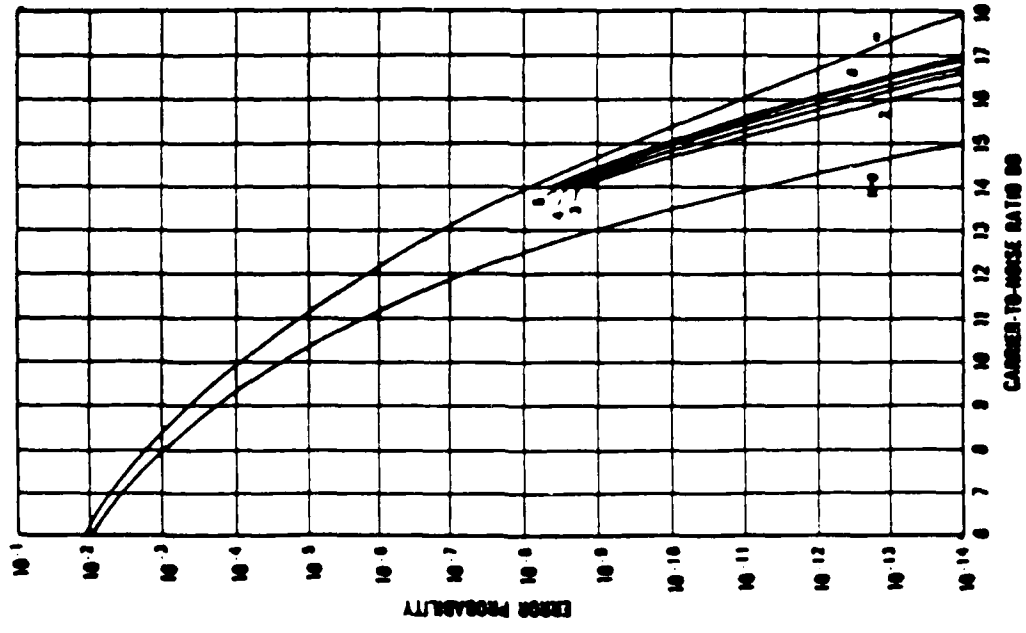
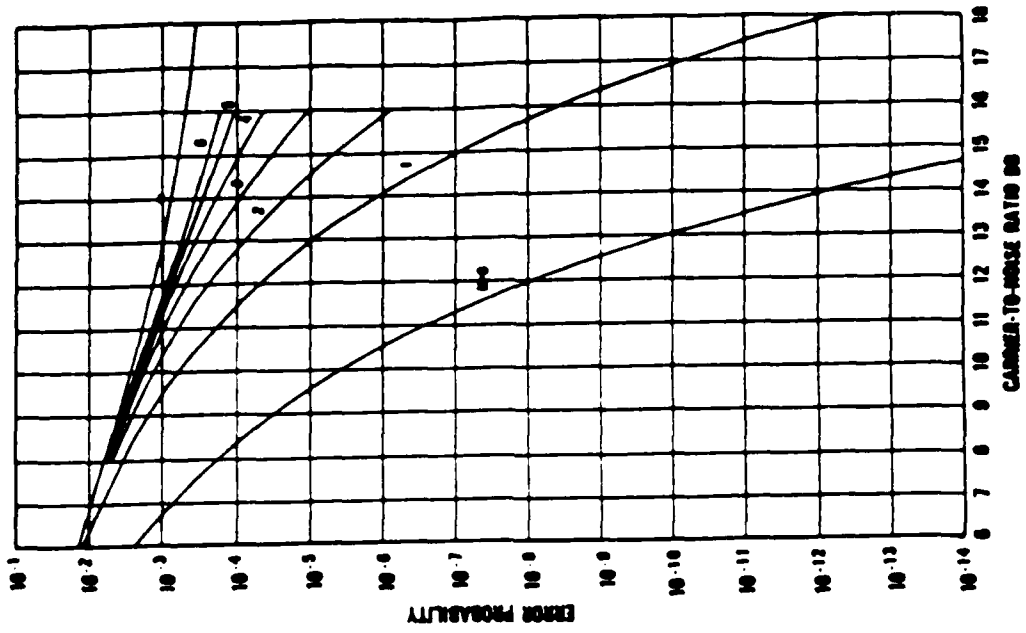

Figure 3-3. BER vs. CIR for CPFSK Signals in Presence of N Interferers

modulation formats, coding rates, etc., it is expected that wideband signals in one channel could be opposite several narrowband users in an oppositely polarized channel. Thus the Gaussian assumption is conservative but quite reasonable.

For the discussion that follows the term, "copolarized channel," refers to the channel in which the link is being analyzed and the term, "cross-polarized channel," refers to the channel with the opposite sense of polarization.

For a repeater transponder (such as those used on DSCS III) being used in a dual-polarized system, the supportable end-to-end data rate per link is:

$$R_d = \frac{\frac{f_1 \cdot \text{EIRP}_{\text{sat}} \cdot G_{\text{ET}} \cdot (1-C_d)}{\gamma \cdot E_b/N_0 \cdot \text{FSL}_d}}{\frac{f_2 \cdot \text{EIRP}_{\text{sat}} \cdot G_{\text{ET}} \cdot (1-C_d)}{B_{\text{ch}} \cdot \text{FSL}_d} + kT_{\text{et}} + \frac{\text{EIRP}'_{\text{sat}} \cdot G_{\text{ET}} \cdot C_d \cdot F}{B'_{\text{ch}} \cdot \text{FSL}_d}} \quad (3-6)$$

where R_d = the achievable link data rate

f_1 = percent of transponder power allocated to signal

$$= \frac{S_i}{S_T + N_{\text{TU}} + S_p}$$

f_2 = percent of transponder power captured by uplink noise

$$= \frac{N_{\text{TU}} + S_p}{S_T + N_{\text{TU}} + S_p}$$

$$S_i = \frac{(1 - C_u) \cdot \text{EIRP}_{\text{ET}} \cdot G_{\text{Sat}}}{\text{FSL}_u}$$

$$S_T = \sum_{i=1}^N \frac{(1 - C_{ui}) \cdot \text{EIRP}_{\text{et},i} \cdot G_{\text{sat},i}}{\text{FSL}_{u,i}}$$

$$S_p = \sum_{i=1}^M \frac{C_{ui} \cdot \text{EIRP}'_{\text{et},i} \cdot G_{\text{sat},i} \cdot A_F \cdot F}{\text{FSL}_{u,i}}$$

- and
- N_{Tu} = total thermal noise in channel = $kT_{\text{sat}}B_{\text{ch}}$
- A_F = attenuation of the cross-polarization noise by the channel filter (=1 for the wideband cross-polarized channel)
- B_{ch} = bandwidth of copolarized channel
- B'_{ch} = bandwidth of cross-polarized channel
- C_d = cross-coupling coefficient of the downlink
- C_u = cross-coupling coefficient of the uplink
- E_b/N_0 = required energy per bit-to-noise ratio
- $\text{EIRP}_{\text{et},i}$ = the transmit EIRP for the i^{th} terminal in the copolarized channel
- $\text{EIRP}'_{\text{et},i}$ = the transmit EIRP for the i^{th} terminal in the cross-polarized channel
- EIRP_{sat} = the satellite EIRP of copolarized channel
- $\text{EIRP}'_{\text{sat}}$ = the satellite EIRP of the cross-polarized channel
- F = the fraction of bandwidth overlap between co- and cross-polarized channel
- FSL_d = downlink free space loss
- FSL_u = uplink free space loss
- G_{et} = the antenna gain of receive earth terminal
- G_{sat} = the antenna gain of the receive satellite antenna connected to the copolarized channel
- γ = transponder suppression loss
- k = Boltzman's constant = 1.38×10^{-23} watts/K-Hz

M = number of links in cross-polarized channel
 N = number of links in copolarized channel
 T_{et} = system noise temperature of the receive earth terminal
 and T_{sat} = system noise temperature of satellite

From equation (3-6) the following can be observed about the effects of the cross-coupling coefficients (C_u and C_d) on link throughput. Nonideal C_u ($C_u = -\infty$ dB) affects link throughput in three ways. Two of these effects, (1) the decrease in received signal power and (2) the increase in equivalent uplink thermal noise, have the same effects, i.e., they cause a decrease in E_b/N_o as discussed previously in Section 3.1. However, these two effects do not significantly reduce link throughput since the uplink C/kT generally is much larger than required to support typical link data rates. However, the third effect of nonideal C_u is to increase the cross-polarization induced thermal noise level at the input of the transponder TWTA, which captures a larger percentage of transponder power. This effect causes the satellite reradiated thermal noise to increase and increases the downlink thermal noise density. In addition, the link receives a smaller percentage of transponder power, thus decreasing the downlink signal power. When this is combined with the additional decrease in signal power and additional increase in thermal noise caused by the downlink cross-coupling coefficient (C_d), it can be seen that the downlink C/kT is severely affected by both C_u and C_d . Since in most cases, the downlink C/kT is the limiting factor in achieving a link data rate, the degrading of downlink C/kT by cross-polarization noise can severely degrade the supportable link data rate.

3.3 CROSS-POLARIZED CHANNEL CONCEPTS

To determine the effects of dual-polarized signals on system throughput, scenarios were developed based upon the

manner in which the cross-polarized channel would be used as listed below:

- Wideband cross-polarized channel placed opposite channels 3 and 4. Intended user of cross-polarized channel would be the GMF community.
- Wideband cross-polarized channel placed opposite channels 5 and 6. Intended user of cross-polarized channel would be the GMF community.
- Wideband cross-polarized channel placed opposite channels 1 and 2. Channels 1 and 2 would contain only ECCM traffic. Intended user of cross-polarized channel would be the GMF community.
- Narrowband cross-polarized channel placed in guardband between channels 1 and 6. Potential user of the cross-polarized channel is WHCA, TACIES, and JCS contingency.

Before describing the actual scenarios, it will be useful to describe the typical deployment of users in each of the channels mentioned above.

Wideband Cross-Polarized Channel - This channel will be used by the GMF community. Typical GMF connectivity consists of hub-spoke interconnections of users within nominally circular theater areas that have a nominal diameter of less than 1000 miles. Each hub can communicate with up to four spoke terminals. Spoke terminals are 8-foot terminals (TSC-93A and TSC-94A) and hub terminals are either 8- or 20-foot terminals (TSC-85A and TSC-100A). The characteristics of these terminals are given in Table 2-4. A typical GMF deployment consists of approximately 30 links. The data rate requirements per link can range from 312 kbps to 2.5 Mbps with typical requirements ranging from 600 kbps to 1.5 Mbps [Ref. 10].

Narrowband Cross-Polarized Channel - This channel would be used to support WHCA, TACIES, and JCS contingency. WHCA is equipped with small, lightweight, transportable LST-8000 terminals to provide communication service between the White

House and the President (or his designated emissary) during Presidential visits within CONUS and to foreign countries. Up to four SHF WHCA terminals may be deployed simultaneously in support of a mission. WHCA requires a 256-kbps full-duplex link from each of the remote locations to the White House via DSCS gateway for either single- or double-hop SATCOM links. A typical TACIES link consists of transmitting 1.544 Mbps from a large hub terminal (20-foot or larger) to a remote 20- to 8-foot terminal. The remote-to-hub requirement is 64 kbps or less. Typically there are only one or two links per satellite area. The JCS contingency deployment typically uses GMF terminals and may be deployed anywhere in the world. Within a deployment the connectivity is a hub-spoke arrangement. Typical deployments consist of 10 links with data rates ranging from 600 kbps to 1.544 Mbps.

Channels 1 and 2 - These channels would be used by ECCM users. Terminal sizes range from 8- to 60-foot terminals. Although some broadcast signals are used, connectivity is generally point-to-point service with low data rate requirements.

Channels 3 and 4 - The users in channels 3 and 4 utilize terminals with sizes ranging from 8- to 60-foot terminals. Connectivity is generally point-to-point service with data rates ranging from 100 Kbps to 10 Mbps. The MBXs used by channels 3 and 4 can be configured in either area coverage (AC) or earth coverage (EC) mode.

Channels 5 and 6 - The terminals used in channels 5 and 6 range from small 8-foot terminals to large 60-foot terminals. However, most terminals are 8-foot terminals with some large hub site terminals. Users are scattered throughout the satellite coverage area. Link data rates range from 1 kbps to 1 Mbps.

Table 3-3 summarizes the 18 scenarios developed in this study. The following paragraphs describe these scenarios.

3.3.1 Scenarios for a Wideband Cross-Polarized Channel Opposite Channels 3 and 4

Five scenarios were developed for this case. The first four scenarios analyzed the cross-polarized channel while scenario 5 analyzed a typical user in channel 4. Figures 3-4 through 3-8 show a block diagram for each scenario. In these five scenarios, the GMF deployment using the cross-polarized channel consisted of a mixture of 20- and 8-foot terminals with a total of 30 links. The satellite antenna was a duplexed GDA with a G/T of 1.5 dB/K and an EIRP of 42.8 dBW. For scenarios 1 through 5, a total of 20 users with an average transmit EIRP of 80 dBW was assumed for channels 3 and 4. In scenarios 1, 2, and 5, it was assumed that the MBX was in EC mode with an EIRP of 30 dBW, while in scenarios 3 and 4, it was assumed that the MBX was in AC mode with an EIRP of 36 dBW.

In scenarios 1 and 3, a link from an 8-foot to 8-foot terminal in the cross-polarized channel was analyzed, while scenarios 2 and 4 analyzed a link from an 8-foot to a 20-foot terminal in the cross-polarized channel. Scenario 5 analyzed a link from a 8-foot to a 40-foot terminal in channel 4.

3.3.2 Scenarios for a Wideband Cross-Polarized Channel Opposite Channels 5 and 6

Four scenarios (scenarios 6 through 9) were developed to analyze the use of a wideband cross-polarized channel opposite channels 5 and 6. Figures 3-9 through 3-12 show a block diagram for each scenario. The GMF deployments and use of the cross-polarized channel in scenarios 6 through 9 are the same as those used in scenarios 1 through 5 (see Section 3.3.1). For channels 5 and 6, a total of 15 links were assumed. For scenarios 6 and 7, two large earth terminals were assumed,

Table 3-3. Summary of Scenarios

WIDEBAND CROSS-POLARIZED CHANNEL OPPOSITE CHANNELS 3 AND 4					
SCENARIO	CHANNEL ANALYZED	XMIT ET	RCV ET	CROSS POLARIZED CHANNEL	COPOLARIZED CHANNEL
1	X-POL	TSC 93A (8 ft)	TSC 85A (8 ft)	GMF DEPLOYMENT	<ul style="list-style-type: none"> ● USE MBX IN EC MODE ● VARIOUS SIZE USERS
2	X-POL	TSC 93A (8 ft)	TSC 85A (20 ft)	GMF DEPLOYMENT	<ul style="list-style-type: none"> ● USE MBX IN EC MODE ● VARIOUS SIZE USERS
3	X-POL	TSC 93A (8 ft)	TSC 85A (8 ft)	GMF DEPLOYMENT	<ul style="list-style-type: none"> ● USE MBX IN EC MODE ● VARIOUS SIZE USERS
4	X-POL	TSC 93A (8 ft)	TSC 85A (20 ft)	GMF DEPLOYMENT	<ul style="list-style-type: none"> ● USE MBX IN AC MODE ● VARIOUS SIZE USERS
5	4	GSC 49 (8 ft)	GSC 52 (40 ft)	GMF DEPLOYMENT	<ul style="list-style-type: none"> ● USE MBX IN EC MODE ● VARIOUS SIZE USERS
WIDEBAND CROSS-POLARIZED CHANNEL OPPOSITE CHANNELS 5 AND 6					
SCENARIO	CHANNEL ANALYZED	XMIT ET	RCV ET	CROSS POLARIZED CHANNEL	COPOLARIZED CHANNEL
6	X-POL	TSC 93A (8 ft)	TSC 85A (8 ft)	GMF DEPLOYMENT	<ul style="list-style-type: none"> ● TWO HIGH-EIRP USERS ● MANY SMALL TERMINALS
7	X-POL	TSC 93A (8 ft)	TSC 85A (20 ft)	GMF DEPLOYMENT	<ul style="list-style-type: none"> ● TWO HIGH-EIRP USERS ● MANY SMALL TERMINALS
8	X-POL	TSC 93A (8 ft)	TSC 85A (20 ft)	GMF DEPLOYMENT	<ul style="list-style-type: none"> ● NO HIGH-EIRP USERS ● MANY SMALL TERMINALS
9	6	SC 3 (8 ft)	SC 4 (35 ft)	GMF DEPLOYMENT	<ul style="list-style-type: none"> ● NO HIGH-EIRP USERS ● MANY SMALL TERMINALS
WIDEBAND CROSS-POLARIZED CHANNEL OPPOSITE CHANNELS 1 AND 2					
SCENARIO	CHANNEL ANALYZED	XMIT ET	RCV ET	CROSS POLARIZED CHANNEL	COPOLARIZED CHANNEL
10	X-POL	TSC 85A (20 ft)	TSC 93A (8 ft)	GMF DEPLOYMENT	<ul style="list-style-type: none"> ● ECCM USERS ● 20 USERS CHANNEL <ul style="list-style-type: none"> - 4 60 ft TERMINALS - 8 20-ft TERMINALS - 8 8-ft TERMINALS
11	X-POL	TSC 85A (20 ft)	TSC 85A (20 ft)	GMF DEPLOYMENT	<ul style="list-style-type: none"> ● ECCM USERS ● 20 USERS CHANNEL <ul style="list-style-type: none"> - 4 60 ft TERMINALS - 8 20-ft TERMINALS - 8 8-ft TERMINALS
12	X-POL	TSC 93A (8 ft)	TSC 85A (8 ft)	GMF DEPLOYMENT	<ul style="list-style-type: none"> ● ECCM USERS ● 20 USERS CHANNEL <ul style="list-style-type: none"> - 4 60 ft TERMINALS - 8 20 ft TERMINALS - 8 8 ft TERMINALS

6101210

Table 3-3. Summary of Scenarios (Continued)

NARROWBAND CROSS-POLARIZED CHANNEL (25 MHz)					
SCENARIO	CHANNEL ANALYZED	XMIT ET	RCV ET	CROSS-POLARIZED CHANNEL	COPOLARIZED CHANNEL
13	X-POL	20-ft HUB	LST-8000 (6-ft)	<ul style="list-style-type: none"> ● VARIOUS SIZE TERMINALS ● 15 LINKS 	<ul style="list-style-type: none"> ● CHANNEL 6-MANY SMALL TERMINALS ● CHANNEL 1 <ul style="list-style-type: none"> - ECCM NETWORK - VARIOUS SIZE USERS
14	1	GSC-49 (8-ft)	GSC-39 (38-ft)	<ul style="list-style-type: none"> ● VARIOUS SIZE TERMINALS ● 15 LINKS 	<ul style="list-style-type: none"> ● CHANNEL 6-MANY SMALL TERMINALS ● CHANNEL 1 <ul style="list-style-type: none"> - ECCM NETWORK - VARIOUS SIZE USERS
15	6	SC-1 (6-ft)	SC-4 (38-ft)	<ul style="list-style-type: none"> ● VARIOUS SIZE TERMINALS ● 15 LINKS 	<ul style="list-style-type: none"> ● CHANNEL 6-MANY SMALL TERMINALS ● CHANNEL 1 <ul style="list-style-type: none"> - ECCM NETWORK - VARIOUS SIZE USERS
NARROWBAND CROSS-POLARIZED CHANNEL (15 MHz)					
SCENARIO	CHANNEL ANALYZED	XMIT ET	RCV ET	CROSS-POLARIZED CHANNEL	COPOLARIZED CHANNEL
16	X-POL	20-ft HUB	LST-8000 (6-ft)	<ul style="list-style-type: none"> ● VARIOUS SIZE TERMINALS ● 15 LINKS 	<ul style="list-style-type: none"> ● CHANNEL 6-MANY SMALL TERMINALS ● CHANNEL 1 <ul style="list-style-type: none"> - ECCM NETWORK - VARIOUS SIZE USERS
17	1	GSC-49 (8-ft)	GSC-39 (38-ft)	<ul style="list-style-type: none"> ● VARIOUS SIZE TERMINALS ● 15 LINKS 	<ul style="list-style-type: none"> ● CHANNEL 6-MANY SMALL TERMINALS ● CHANNEL 1 <ul style="list-style-type: none"> - ECCM NETWORK - VARIOUS SIZE USERS
18	6	SC-1 (6-ft)	SC-4 (38-ft)	<ul style="list-style-type: none"> ● VARIOUS SIZE TERMINALS ● 15 LINKS 	<ul style="list-style-type: none"> ● CHANNEL 6-MANY TERMINALS ● CHANNEL 1 <ul style="list-style-type: none"> - ECCM NETWORK - VARIOUS SIZE USERS

610122 0

SATELLITE NOISE TEMPERATURE = 800 K
 RHCP CHANNEL 3.4 (BW = 170 MHz)
 LHCP CHANNEL XP (BW = 100 MHz)
 $E_b/N_0 = 7.5$ dB

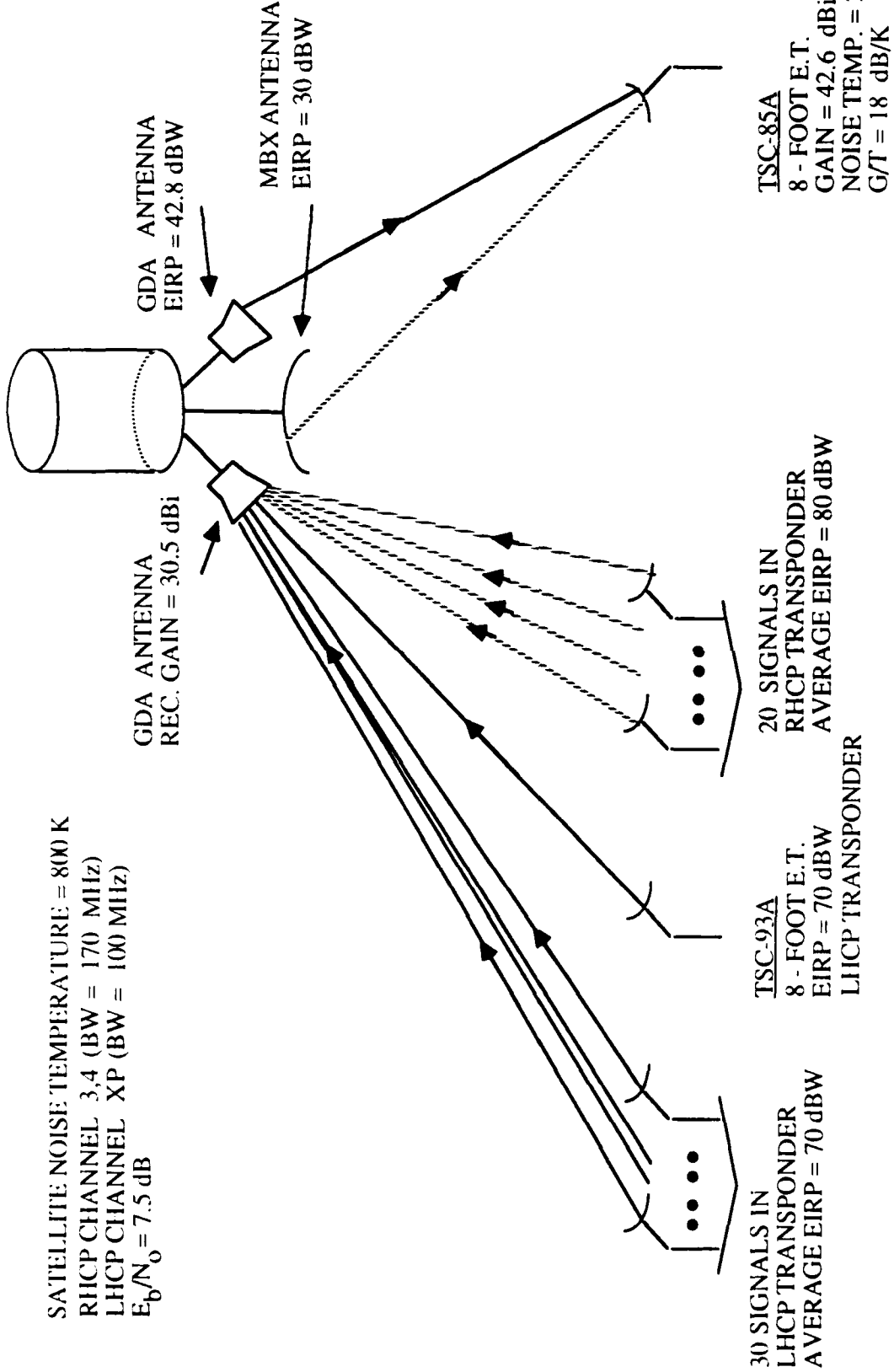

Figure 3-4. Block Diagram for Scenario 1

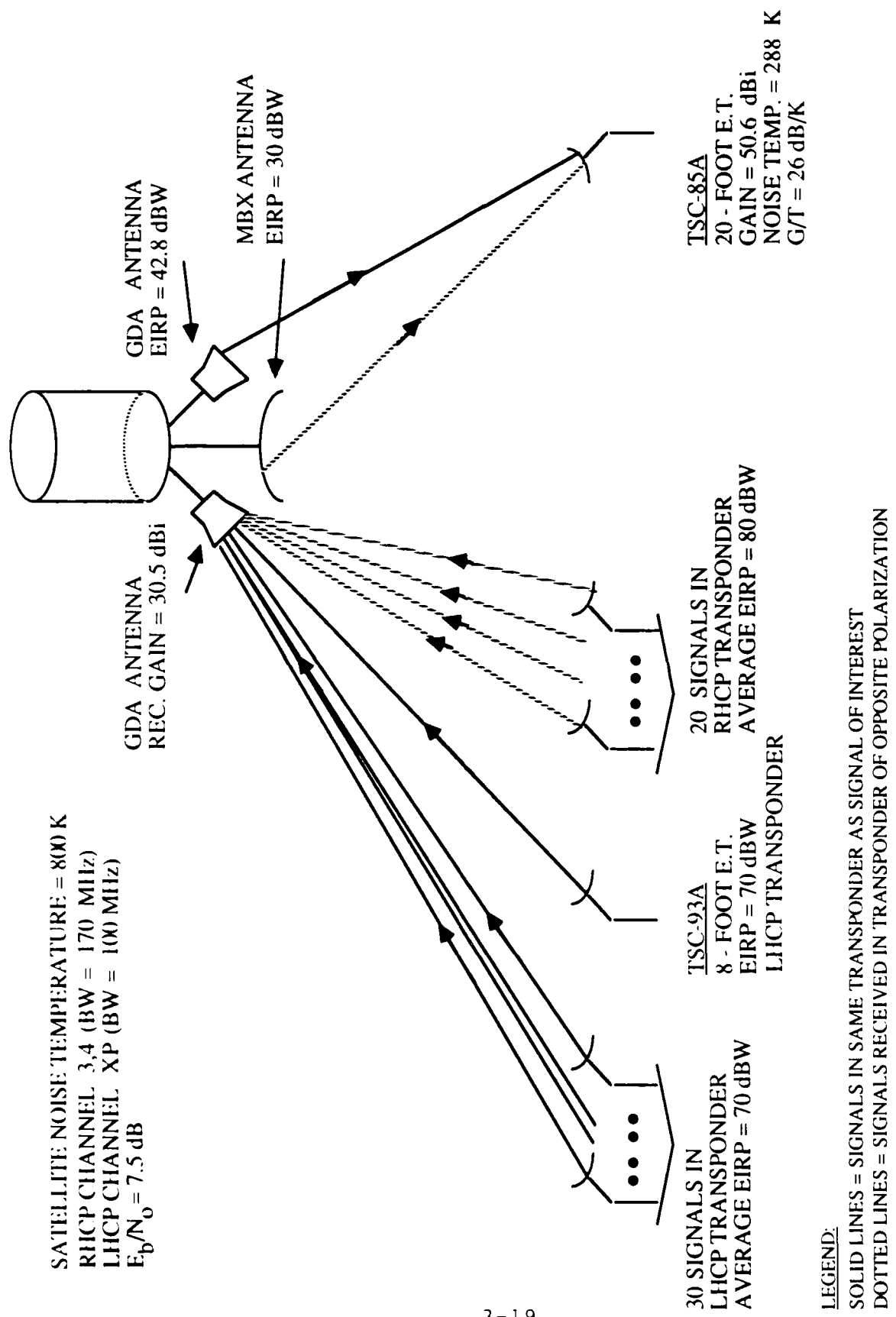

Figure 3-5. Block Diagram for Scenario 2

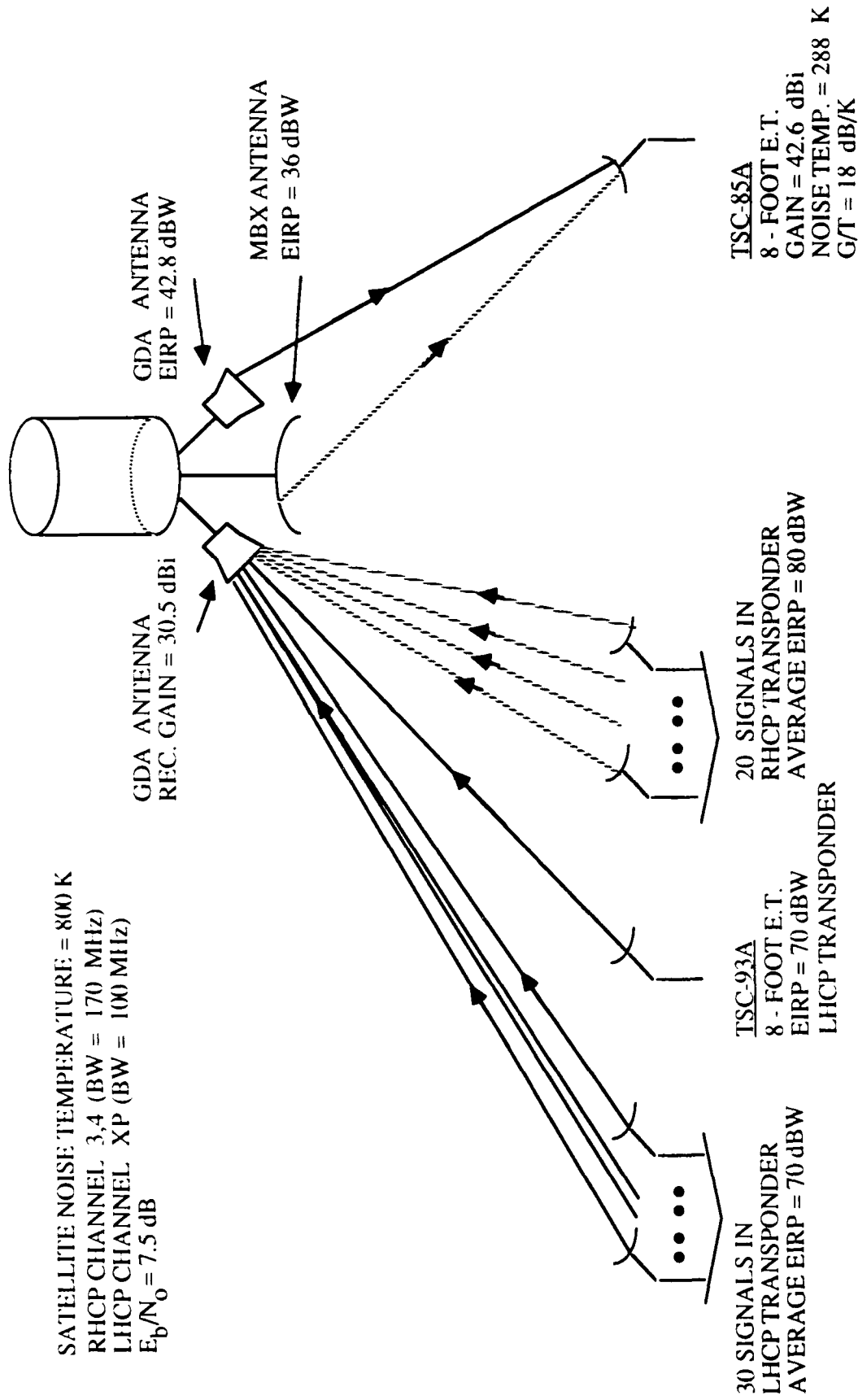
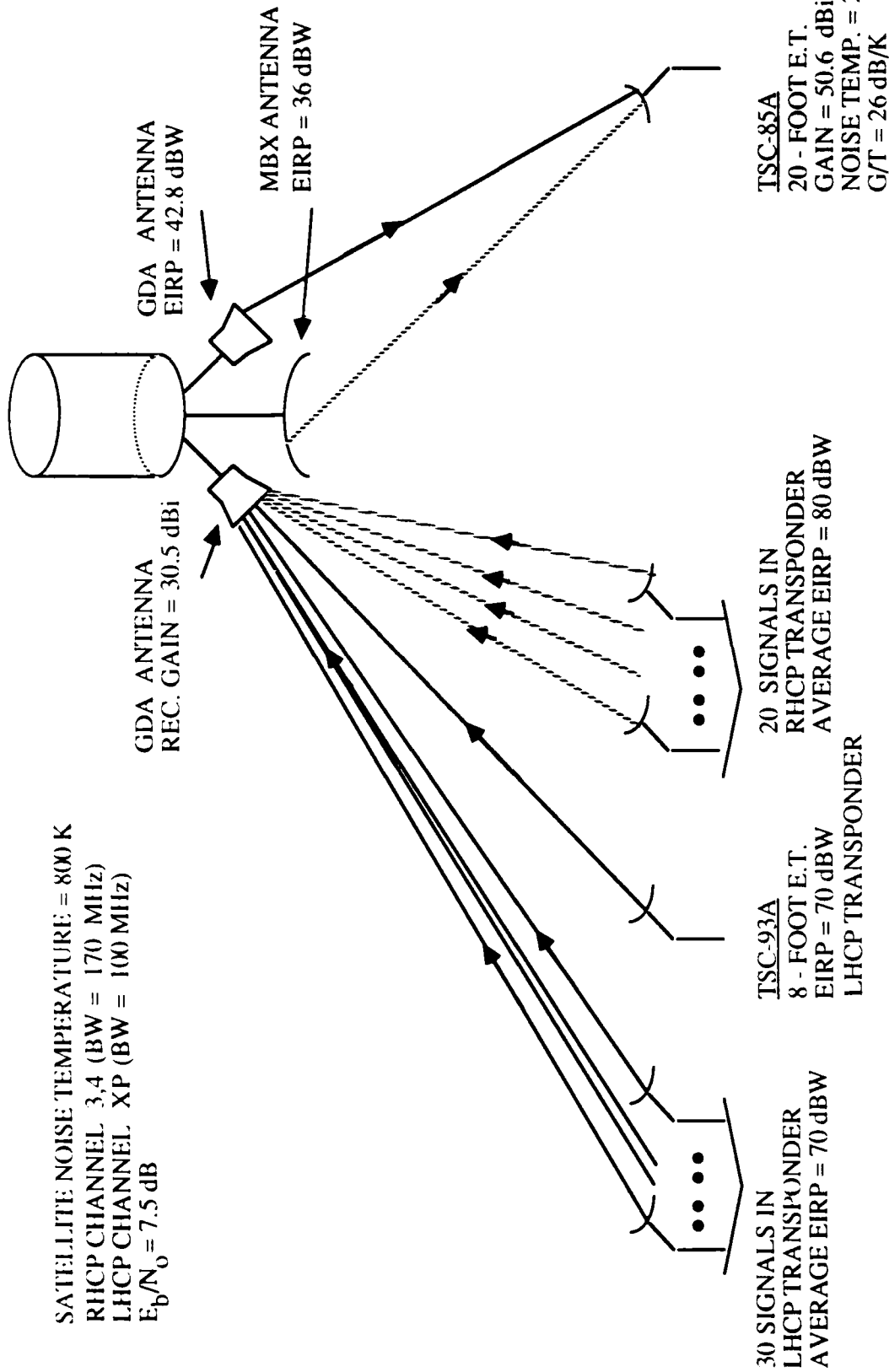

Figure 3-6. Block Diagram for Scenario 3

SATELLITE NOISE TEMPERATURE = 800 K
 RHCP CHANNEL 3,4 (BW = 170 MHz)
 LHCP CHANNEL XP (BW = 100 MHz)
 $E_b/N_0 = 7.5 \text{ dB}$



TSC-85A
 20 - FOOT E.T.
 GAIN = 50.6 dBi
 NOISE TEMP. = 288 K
 G/T = 26 dB/K

TSC-93A
 8 - FOOT E.T.
 EIRP = 70 dBW
 LHCP TRANSPONDER

30 SIGNALS IN
 LHCP TRANSPONDER
 AVERAGE EIRP = 70 dBW

20 SIGNALS IN
 RHCP TRANSPONDER
 AVERAGE EIRP = 80 dBW

LEGEND:
 SOLID LINES = SIGNALS IN SAME TRANSPONDER AS SIGNAL OF INTEREST
 DOTTED LINES = SIGNALS RECEIVED IN TRANSPONDER OF OPPOSITE POLARIZATION

Figure 3-7. Block Diagram for Scenario 4

SATELLITE NOISE TEMPERATURE = 800 K
 RHCP CHANNEL 4 (BW = 85 MHz)
 LHCP CHANNEL XP (BW = 100 MHz)
 $E_b/N_0 = 7.5$ dB

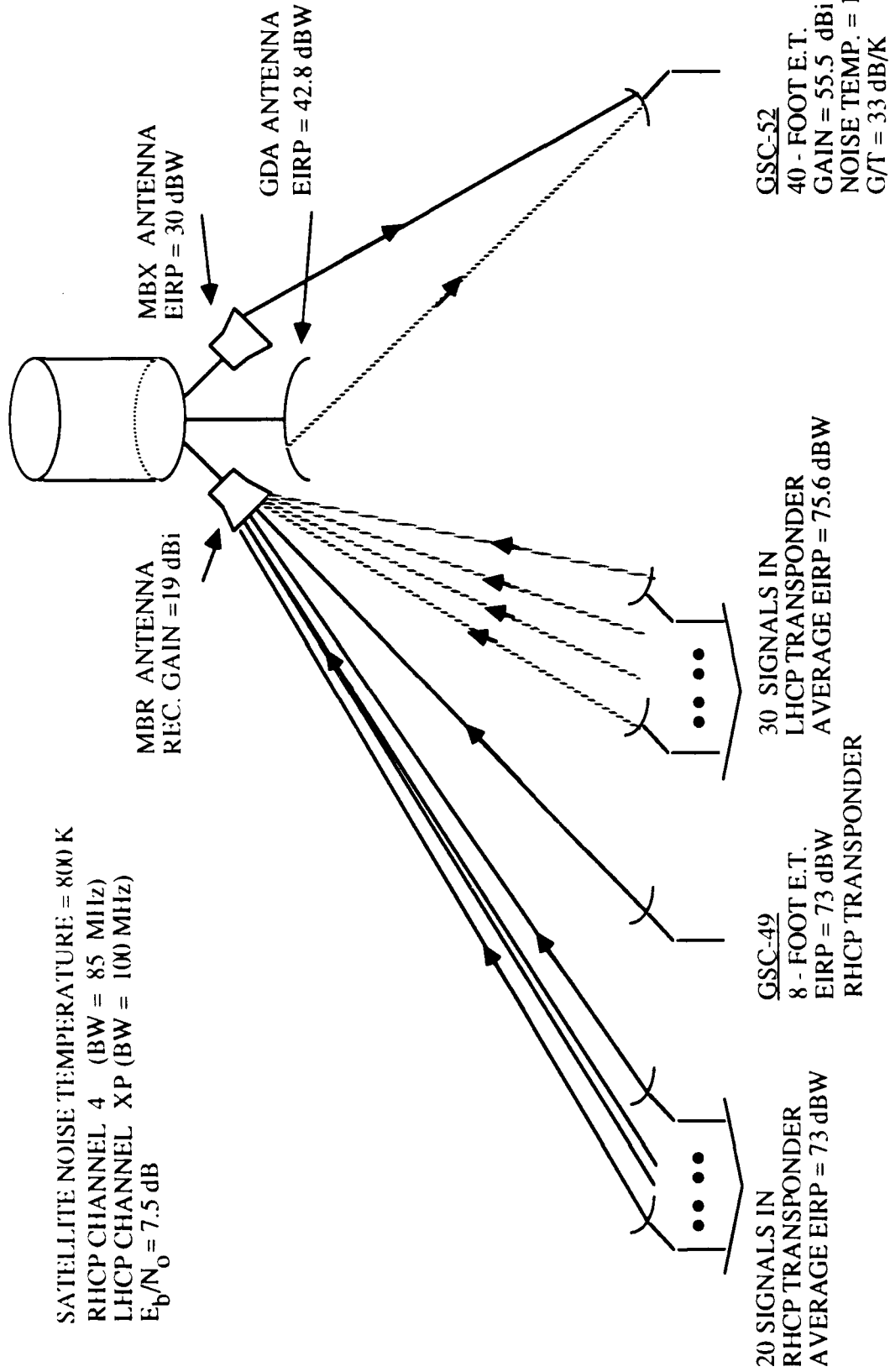

LEGEND:

SOLID LINES = SIGNALS IN SAME TRANSPONDER AS SIGNAL OF INTEREST
 DOTTED LINES = SIGNALS RECEIVED IN TRANSPONDER OF OPPOSITE POLARIZATION

Figure 3-8. Block Diagram for Scenario 5

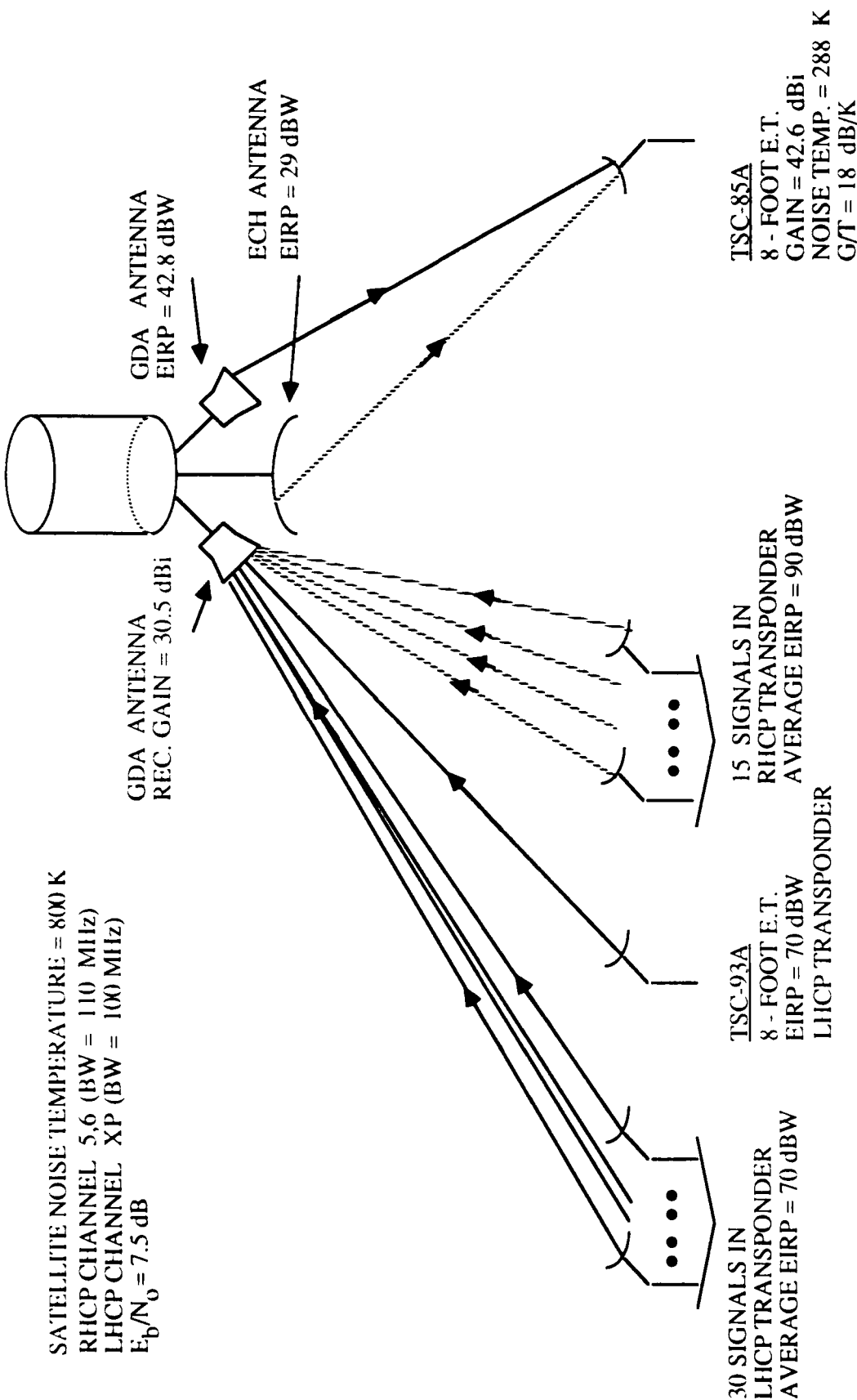

Figure 3-9. Block Diagram for Scenario 6

SATELLITE NOISE TEMPERATURE = 800 K
 RHCP CHANNEL 5,6 (BW = 110 MHz)
 LHCP CHANNEL XP (BW = 100 MHz)
 $E_b/N_0 = 7.5 \text{ dB}$

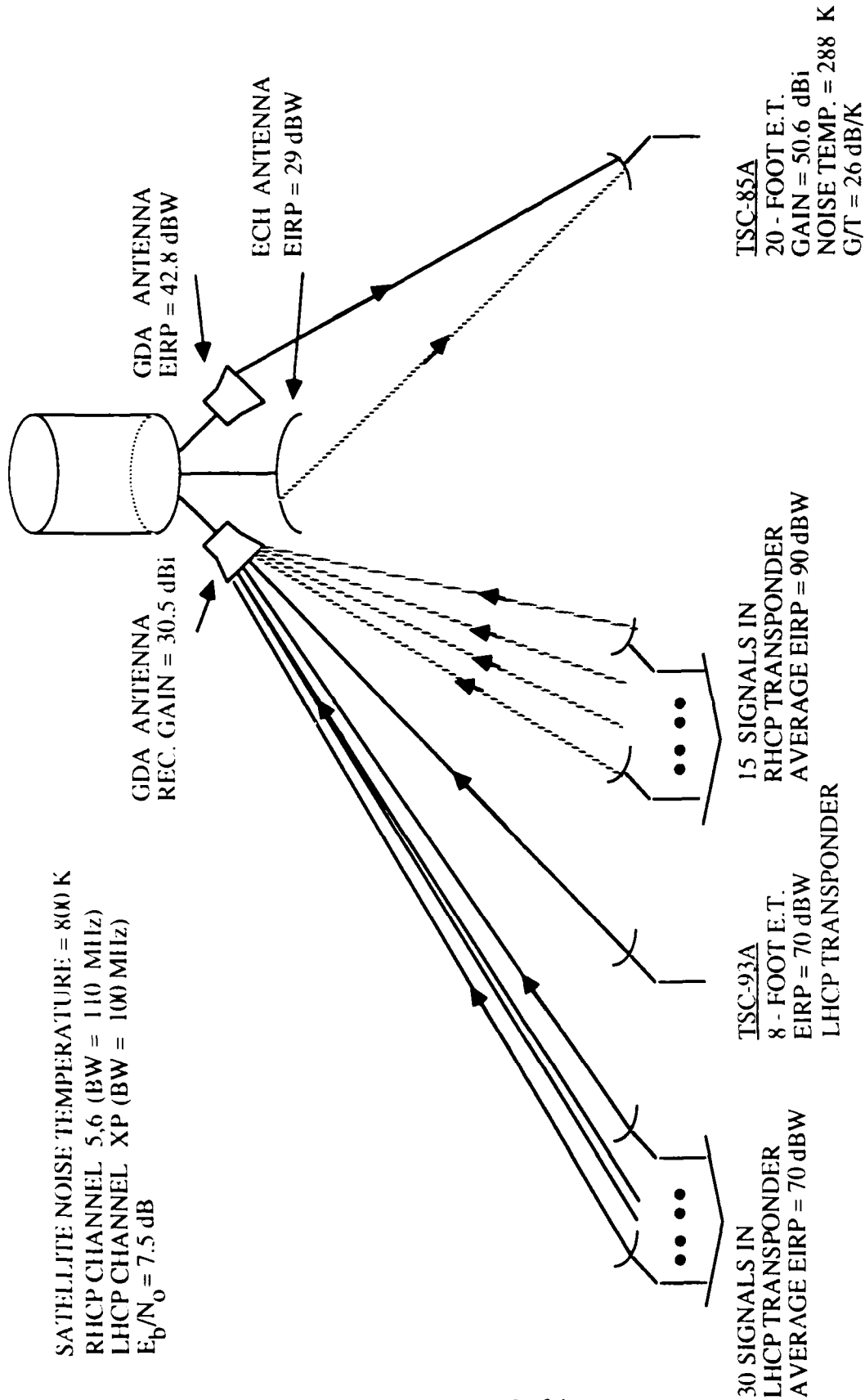
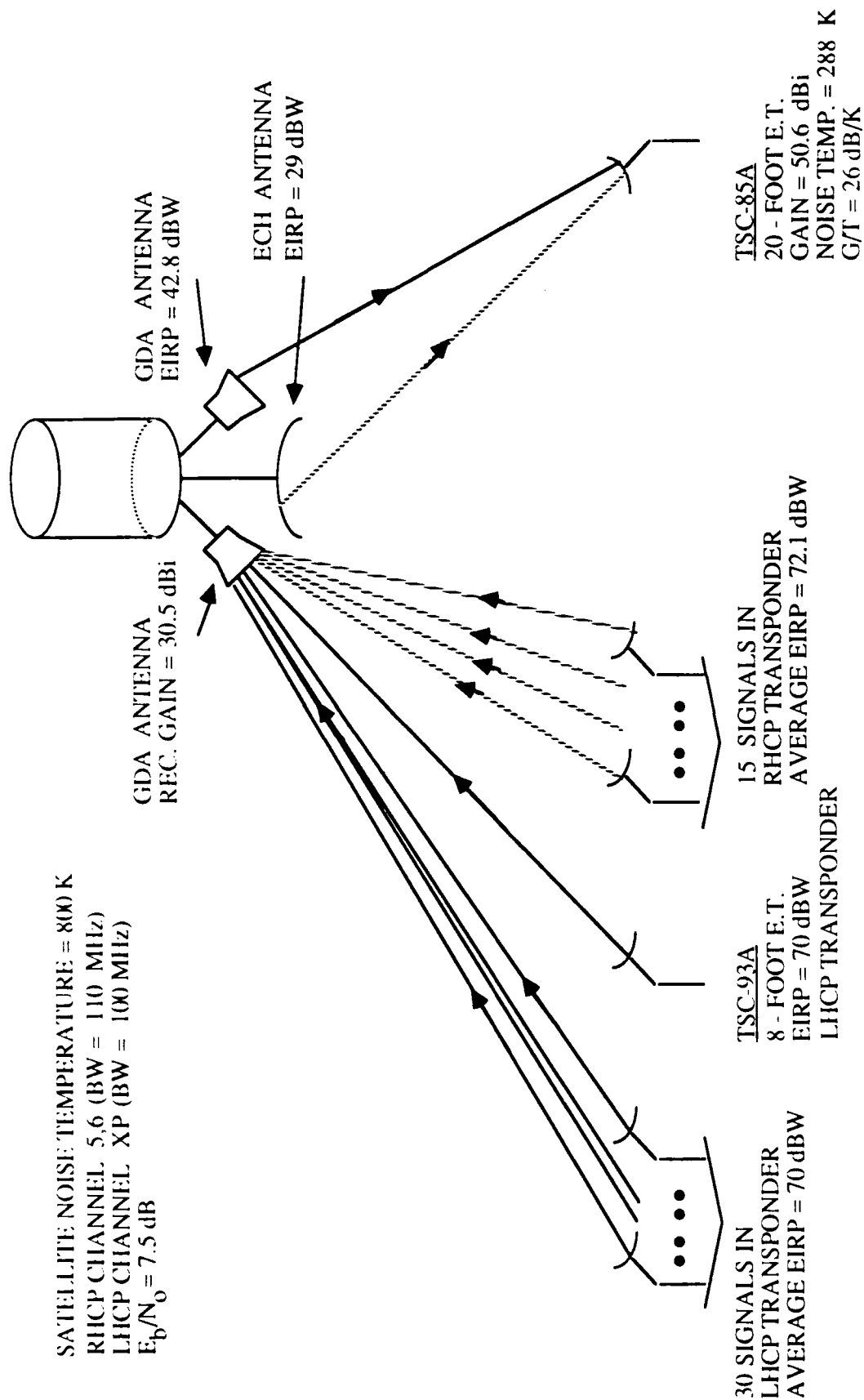

Figure 3-10. Block Diagram for Scenario 7



SATELLITE NOISE TEMPERATURE = 800 K
 RHCP CHANNEL 5,6 (BW = 110 MHz)
 LHCP CHANNEL XP (BW = 100 MHz)
 $E_b/N_0 = 7.5$ dB

TSC-85A
 20 - FOOT E.T.
 GAIN = 50.6 dBi
 NOISE TEMP. = 288 K
 G/T = 26 dB/K

TSC-93A
 8 - FOOT E.T.
 EIRP = 70 dBW
 LHCP TRANSPONDER

15 SIGNALS IN
 RHCP TRANSPONDER
 AVERAGE EIRP = 72.1 dBW

30 SIGNALS IN
 LHCP TRANSPONDER
 AVERAGE EIRP = 70 dBW

LEGEND:

SOLID LINES = SIGNALS IN SAME TRANSPONDER AS SIGNAL OF INTEREST
 DOTTED LINES = SIGNALS RECEIVED IN TRANSPONDER OF OPPOSITE POLARIZATION

Figure 3-11. Block Diagram for Scenario 8

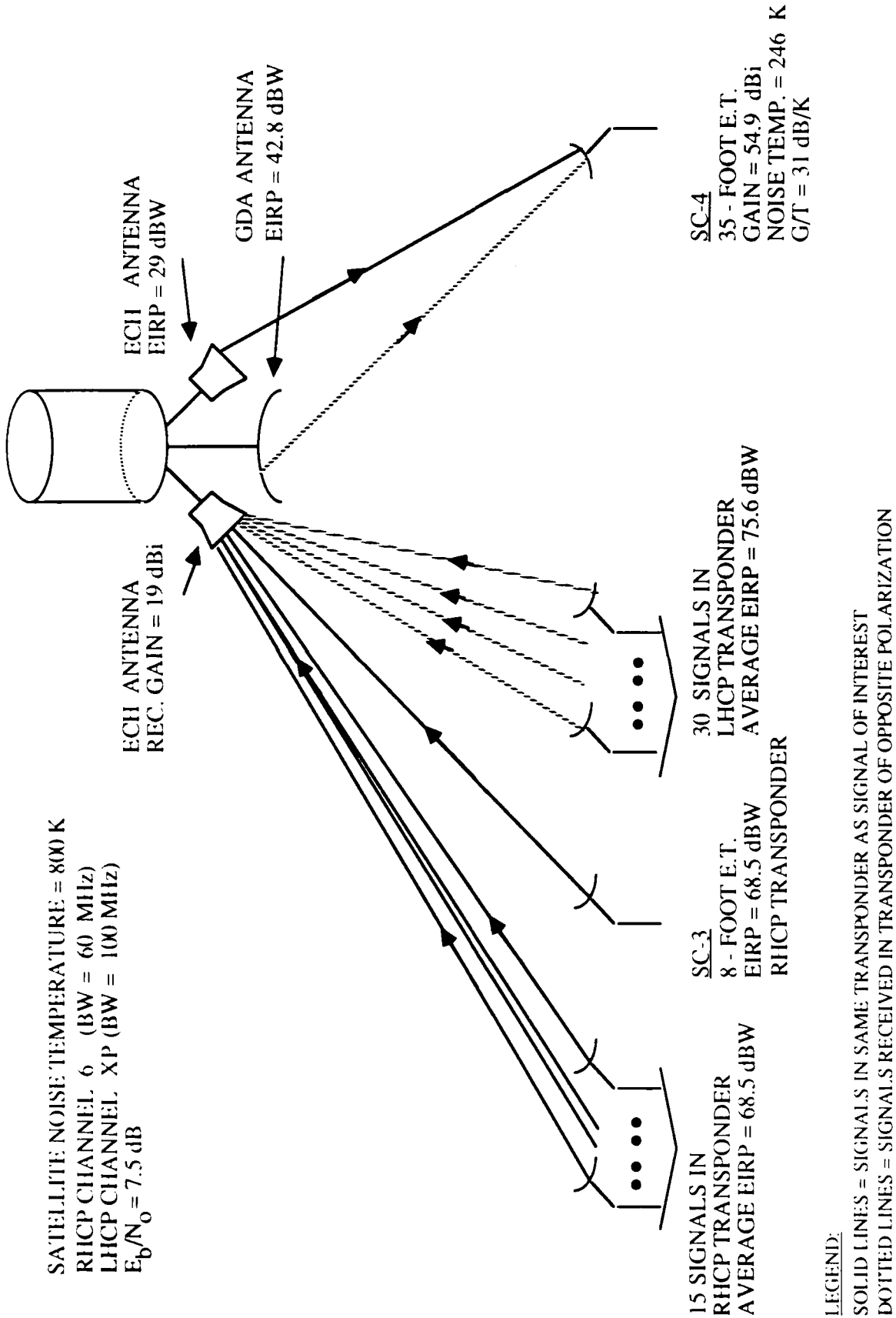

Figure 3-12. Block Diagram for Scenario 9

while in scenarios 8 and 9 large terminals were not used. The satellite EIRP for channels 5 and 6 was 29 dBW.

In scenario 6, a link from an 8-foot TSC-93A to an 8-foot TSC-85A in the cross-polarized channel was analyzed. In scenarios 7 and 8, a link from an 8-foot TSC-93A to a 20-foot TSC-85A in the cross-polarized channel was analyzed. Scenario 9 analyzed a link from an 8-foot SC-3 to a 35-foot SC-4 in channel 6.

3.3.3 Scenarios for a Wideband Cross-Polarized Channel Opposite Channels 1 and 2

Three scenarios (scenarios 10, 11, and 12) were developed to analyze the use of a wideband cross-polarized channel opposite channels 1 and 2. Figures 3-13, 3-14, and 3-15 show a block diagram for each scenario. The GMF deployments and use of the cross-polarized channel in these scenarios are the same as those used in scenarios 1 through 5 (see Section 3.3.1). Channels 1 and 2 would be used by ECCM users. In each scenario, 20 links per channel were assumed. The distribution of terminals for each channel was four 60-foot terminals (AN/FSC-78), eight 20-foot AN/GSC-49 terminals, and eight 8-foot AN/GSC-49 terminals. The satellite EIRP for each channel was 33 dBW.

In scenario 10, a link from a 20-foot to an 8-foot terminal in the cross-polarized channel was analyzed. Scenario 11 analyzed a link from a 20-foot to a 20-foot terminal in the cross-polarized channel, while in scenario 12, a link from an 8-foot to an 8-foot terminal in the cross-polarized channel was analyzed.

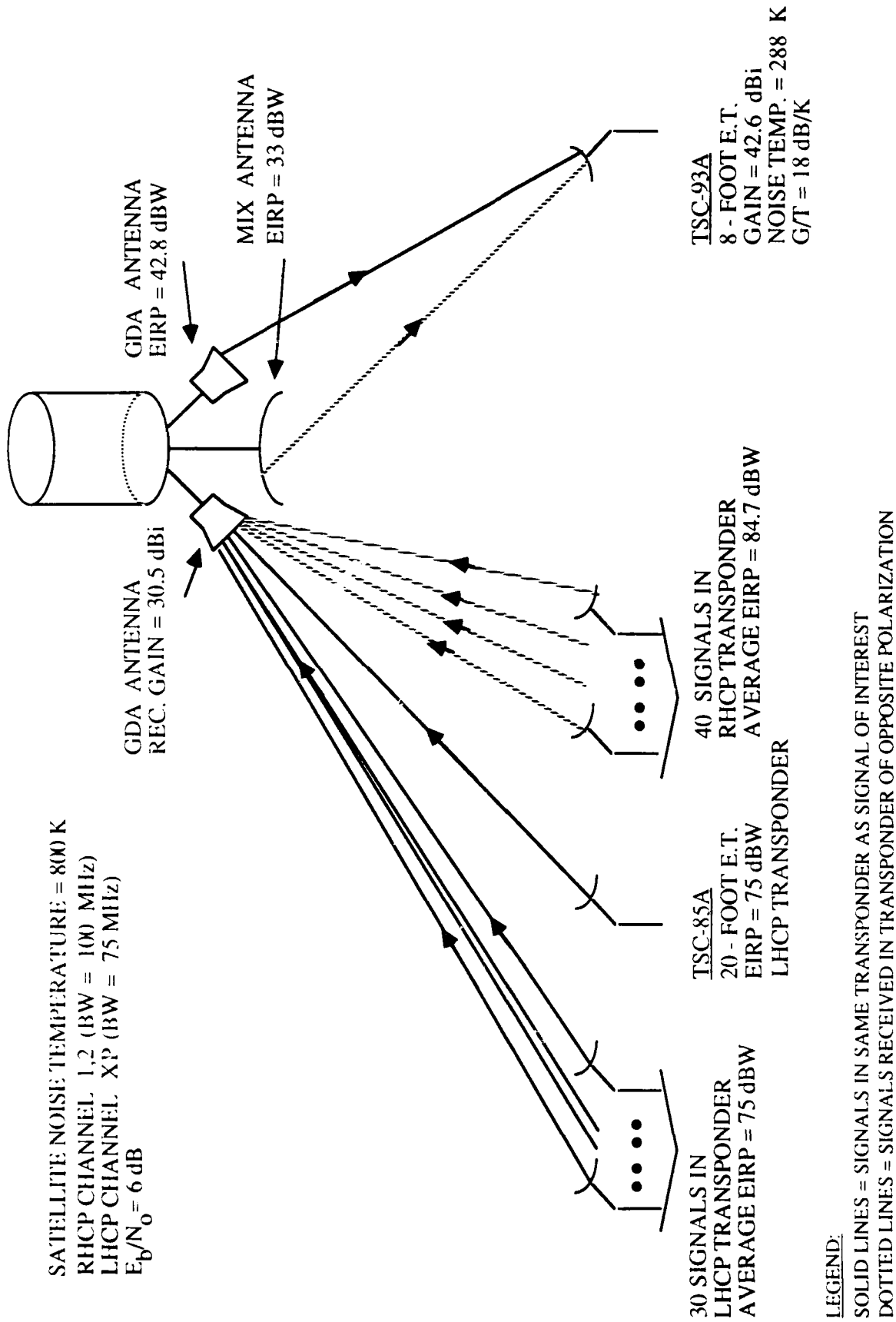

Figure 3-13. Block Diagram for Scenario 10

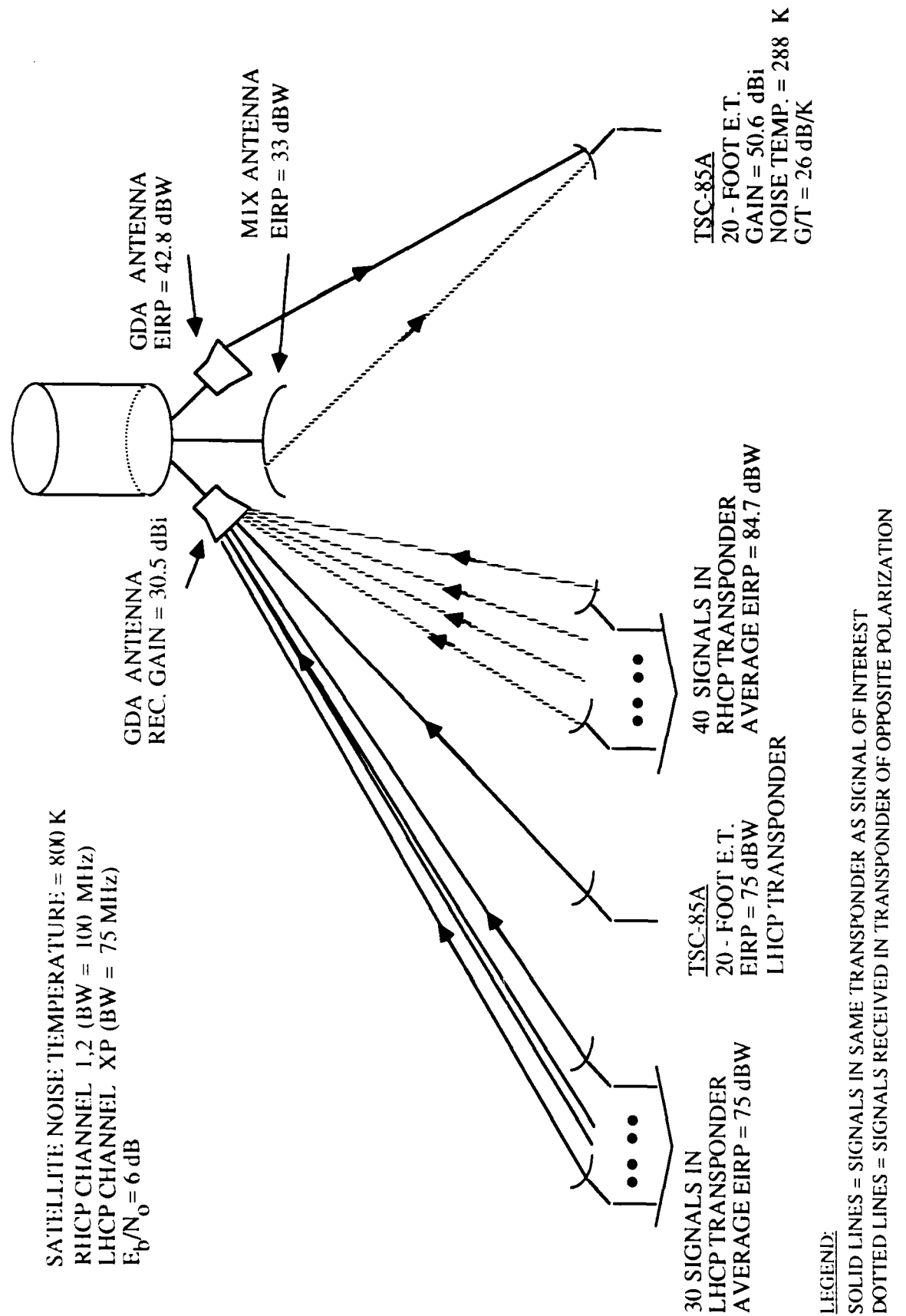

Figure 3-14. Block Diagram for Scenario 11

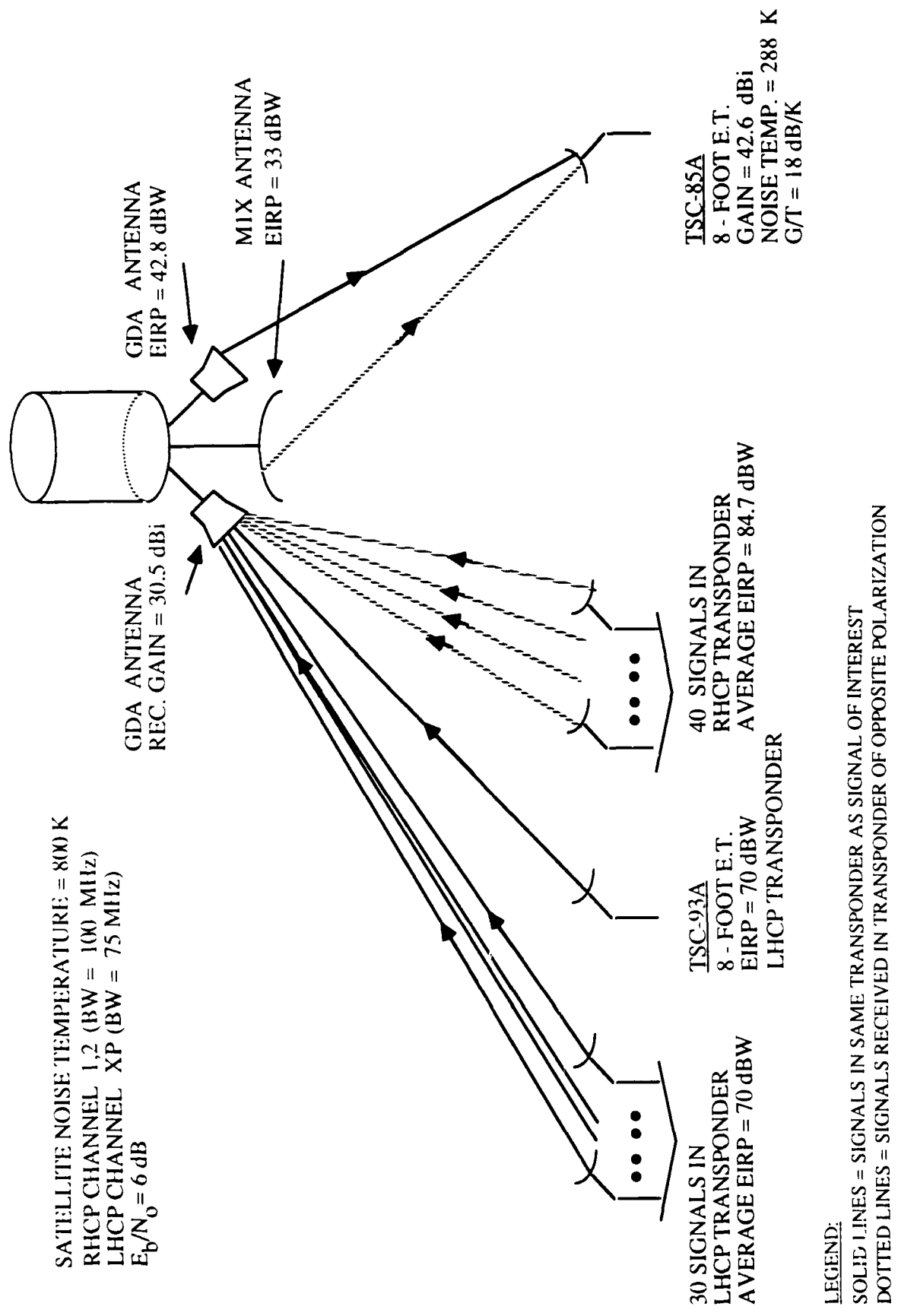

Figure 3-15. Block Diagram for Scenario 12



3.3.4 Scenarios for Narrowband Cross-Polarized Channel

Six scenarios (scenarios 13 through 18) were developed to analyze the use of a narrowband cross-polarized channel placed opposite the 25-MHz guardband. In scenarios 13, 14, and 15, the cross-polarized channel was 25-MHz wide, while scenarios 16, 17, and 18 are the same scenarios as 13, 14, and 15, except that the bandwidth of the cross-polarized channel was reduced to 15 MHz. Figures 3-16, 3-17, and 3-18 show a block diagram for scenarios 13, 14, and 15.

For all six scenarios it was assumed that the cross-polarized channel supported 15 links, divided into the following manner: five WHCA links, one TACIES link, and nine JCS contingency links. The G/T of ECH used by the cross-polarized channel was -10 dB/K and the EIRP of the channel was 32 dBW. For channel 1, it was assumed that there were 15 links with an average transmit EIRP of 73 dBW per terminal. For channel 6, it was assumed that there were 15 links with an average transmit EIRP of 66 dBW per terminal.

Scenarios 13 and 16 analyzed a link from a 20-foot terminal to a 6-foot WHCA terminal in the cross-polarized channel. Scenarios 14 and 17 analyzed a link between an 8-foot GSC-49 terminal to a 38-foot GSC-39 terminal in channel 1. Scenarios 15 and 18 analyzed a link between a 6-foot SC-1 terminal to a 38-foot SC-4 terminal in channel 6.

3.4 MINIMUM ACCEPTANCE CRITERIA

The maximum benefit to system throughput provided by dual-polarized signals would be to double throughput in those frequency bands that support dual-polarized signals. This would require perfect isolation between opposite polarized signals and thus is not achievable. In this study it was decided that the minimum benefit that must be achieved to merit

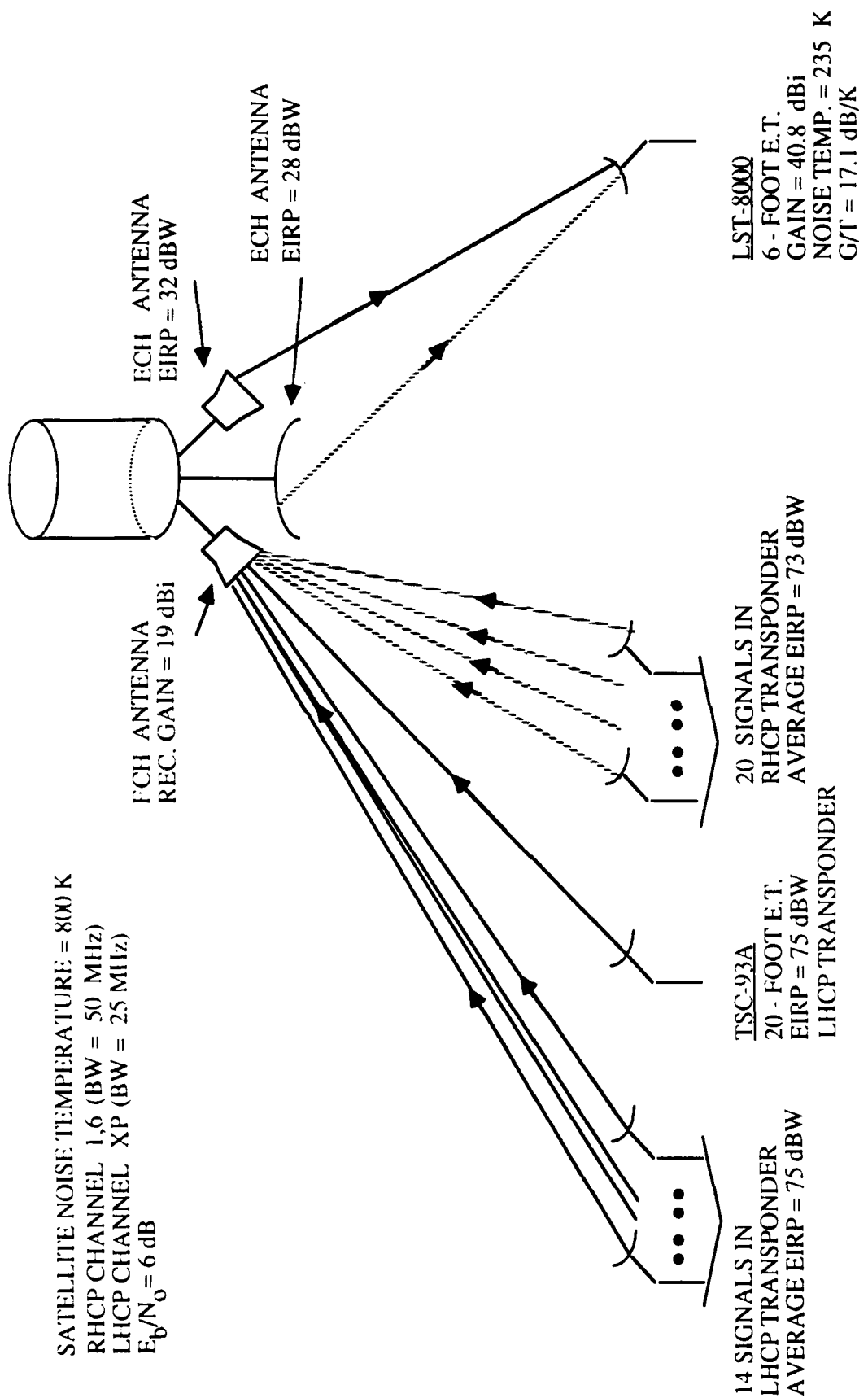

SATELLITE NOISE TEMPERATURE = 800 K
 RHCP CHANNEL 1.6 (BW = 50 MHz)
 LHCP CHANNEL XP (BW = 25 MHz)
 $E_p/N_0 = 6$ dB

FCH ANTENNA
 REC. GAIN = 19 dBi

ECH ANTENNA
 EIRP = 32 dBW

ECH ANTENNA
 EIRP = 28 dBW

14 SIGNALS IN
 LHCP TRANSPONDER
 AVERAGE EIRP = 75 dBW

TSC-93A
 20 - FOOT E.T.
 EIRP = 75 dBW
 LHCP TRANSPONDER

20 SIGNALS IN
 RHCP TRANSPONDER
 AVERAGE EIRP = 73 dBW

LST-8000
 6 - FOOT E.T.
 GAIN = 40.8 dBi
 NOISE TEMP. = 235 K
 G/T = 17.1 dB/K

LEGEND:
 SOLID LINES = SIGNALS IN SAME TRANSPONDER AS SIGNAL OF INTEREST
 DOTTED LINES = SIGNALS RECEIVED IN TRANSPONDER OF OPPOSITE POLARIZATION

Figure 3-16. Block Diagram for Scenario 13

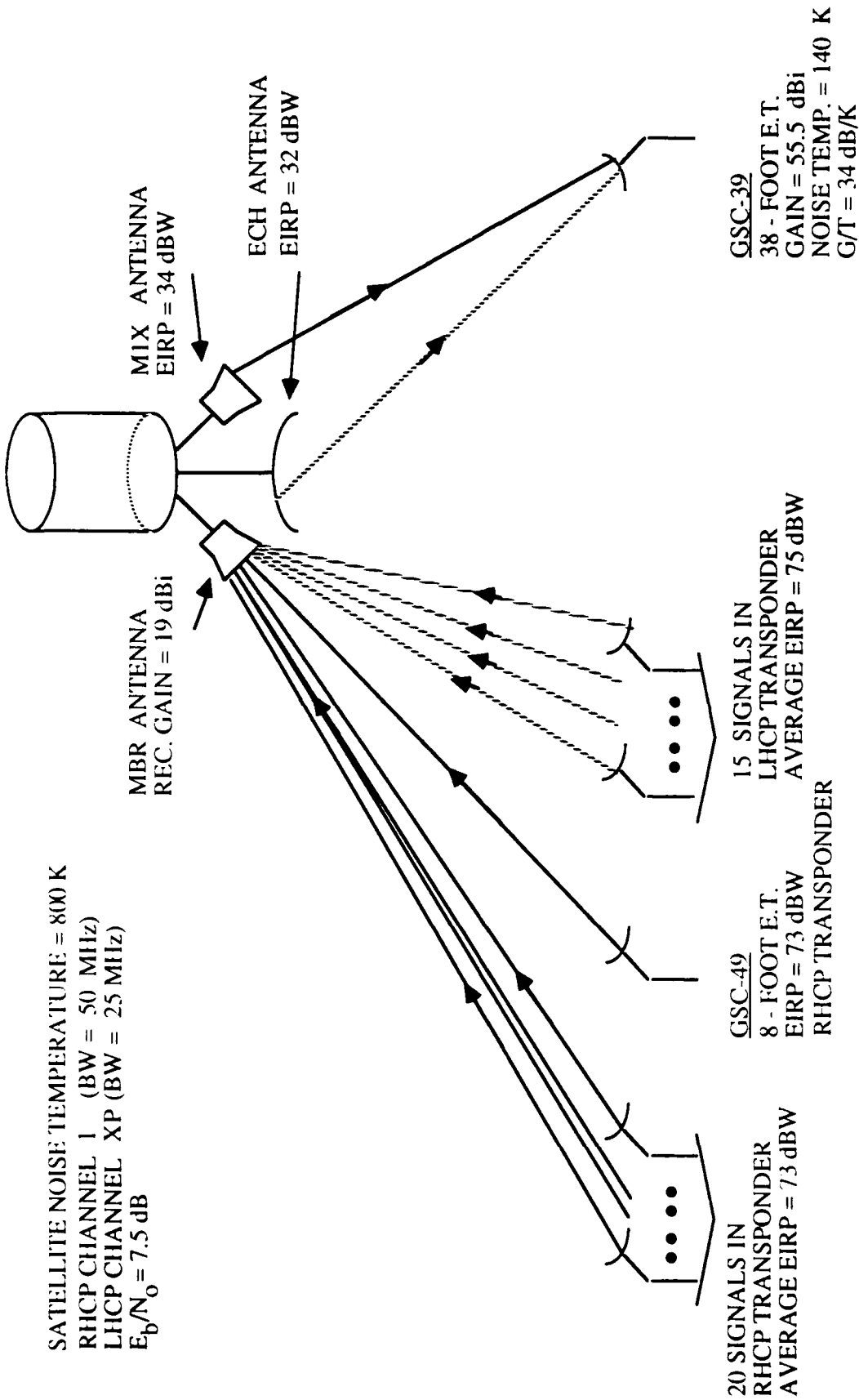

Figure 3-17. Block Diagram for Scenario 14

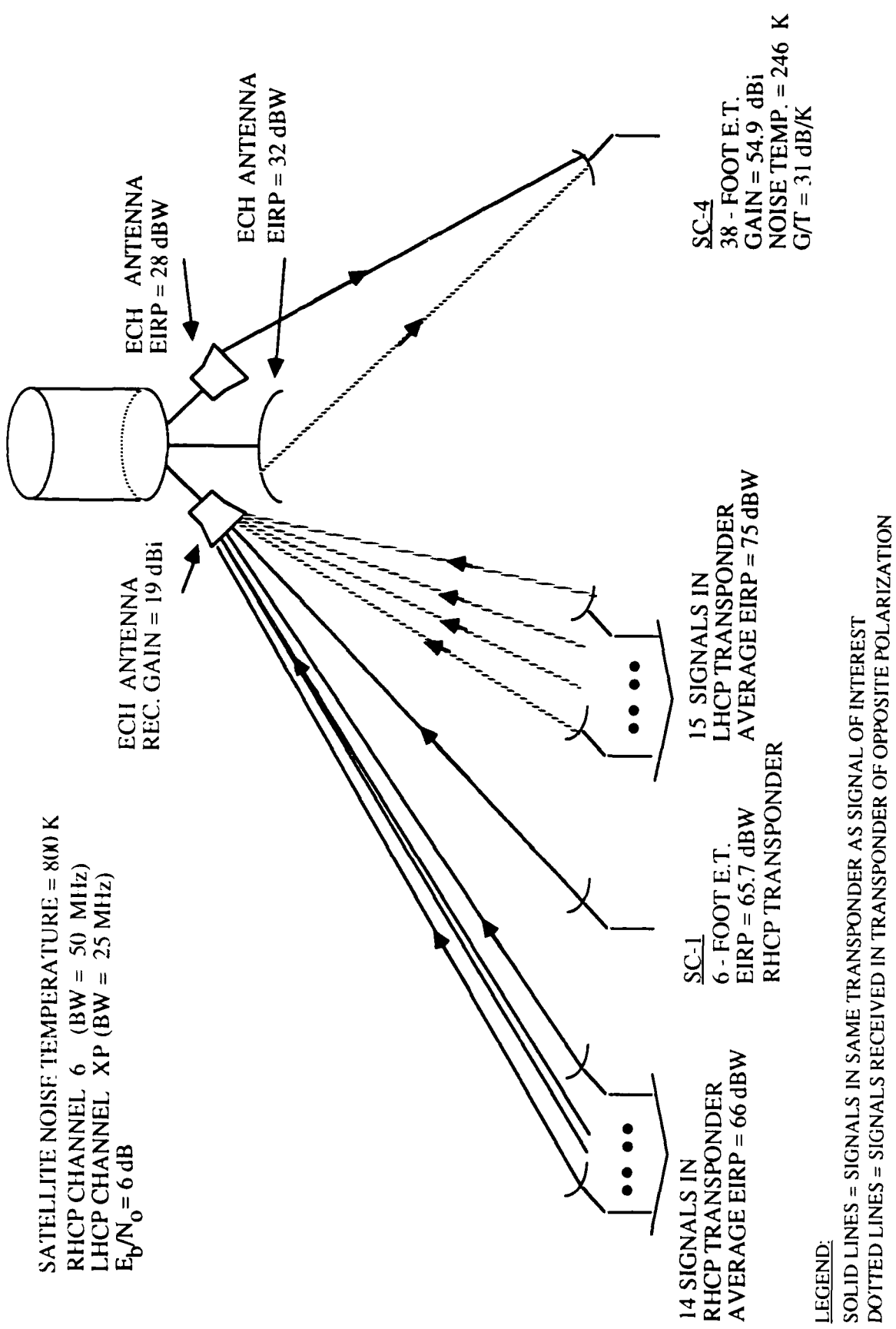

Figure 3-18. Block Diagram for Scenario 15

further study or recommendation for implementation would be an overall system throughput improvement of 1 dB (25.9 percent) in those frequency bands using the dual-polarized signals. This would allow each of the two polarized channels to suffer a 2-dB loss in system throughput when compared to the throughput if perfect isolation could be achieved.

The rationale for a 1-dB improvement is that other improvement techniques currently being considered as SHF improvements to the DSCS III satellite will also provide 1 dB of throughput improvement [Ref. 10]. These techniques include:

- Use of linearizer for channel 2
- Use of shaped ECH antenna pattern for channels 5 and/or 6.

For the placing of the wideband cross-polarized channel opposite channels 1 and 2, a different criteria is used. This is because channels 1 and 2 would be used to support ECCM users and no degradation in service to the ECCM users was allowed. This is achievable because the cross-polarized signals interfering with channels 1 and 2 would appear to be small jammers. Users of channels 1 and 2 can tolerate small jammers since the users of these channels use a spread-spectrum waveform. The minimum criteria for this concept was that the cross-polarized channel must be able to support a typical GMF deployment. As stated in Section 3.3, a typical GMF deployment consists of approximately 30 links with data rates per link ranging from 600 kbps to 1.5 Mbps.

Because the narrowband cross-polarized channel is only 15 to 25 MHz wide, allowing a loss of 2 dB in throughput in existing FDMA channels due to cross-polarization interference would not provide the 25 percent improvement in overall system throughput. Assuming the cross-polarized channel will provide only half the throughput of channel 6, then the maximum

increase in throughput is 50 percent. In order to achieve a 25 percent increase, a loss of no more than 0.8 dB can be tolerated.

CHAPTER 4

RESULTS

In this chapter, the results of the 18 scenarios described in Section 3.3 are discussed. It should be pointed out that the results presented in this section are based on using the specified values of axial ratio for both the satellite and earth terminal antennas. For each scenario, a graph of data rate versus C_u (uplink cross-coupling coefficient) is presented. The five curves drawn on each graph correspond to different values of C_d (downlink cross-coupling coefficient). The values of C_d are -100 dB (corresponding to perfect isolation), -25 dB, -15 dB, and -10 dB. A fifth curve is shown in each graph that corresponds to the C_d based upon the axial ratio specifications on the satellite transmit and receive earth terminal antennas. Also labeled on each graph is the C_u obtained from the specifications on axial ratios of the transmit earth terminal and satellite receive antennas. Finally, each graph shows the case (i.e., a dotted line) that corresponds to a 2-dB reduction in data rate compared with that achieved given perfect cross-polarized isolation.

4.1 WIDEBAND CROSS-POLARIZED CHANNEL

As discussed in Section 3.3, 12 scenarios were developed to analyze the use of a wideband cross-polarized channel. Five scenarios were used to analyze the effects of placing the wideband cross-polarized channel opposite channels 3 and 4. Figures 4-1 through 4-5 show the supportable link data rates. For scenarios 1 through 4, it can be seen that the major cause in degradation to link throughput is inadequate uplink cross-polarization isolation (C_u). This is to be expected since the downlink EIRP of the cross-polarized channel is 7 to 13 dB higher than the EIRP of channels 3 and 4. This advantage in EIRP allows the cross-polarized channel to overcome the effects of inadequate downlink cross-polarization isolation (C_d). As

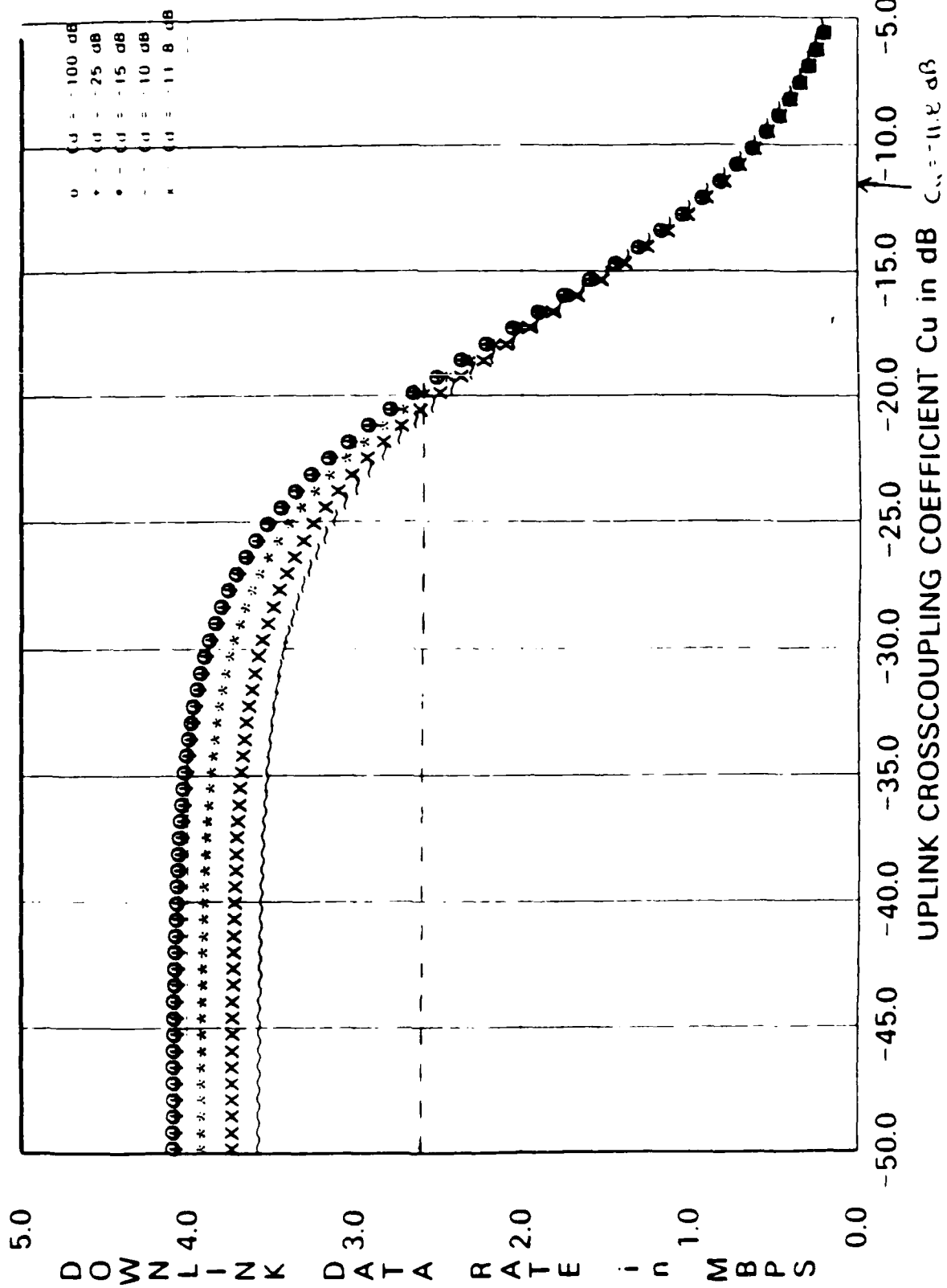

Figure 4-1. Link Data Rate vs. C_u for Scenario 1

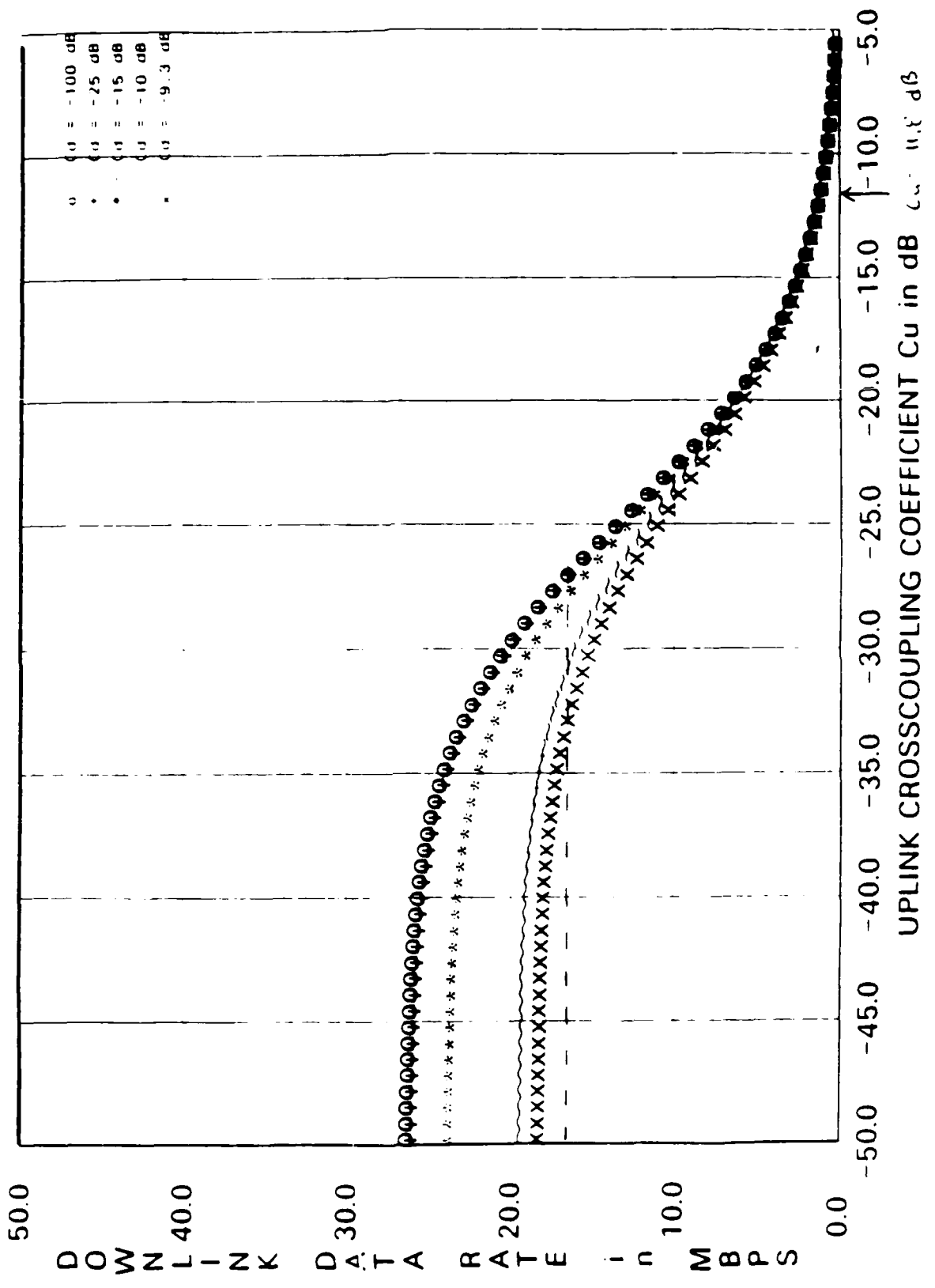

Figure 4-2. Link Data Rate vs. C_u for Scenario 2

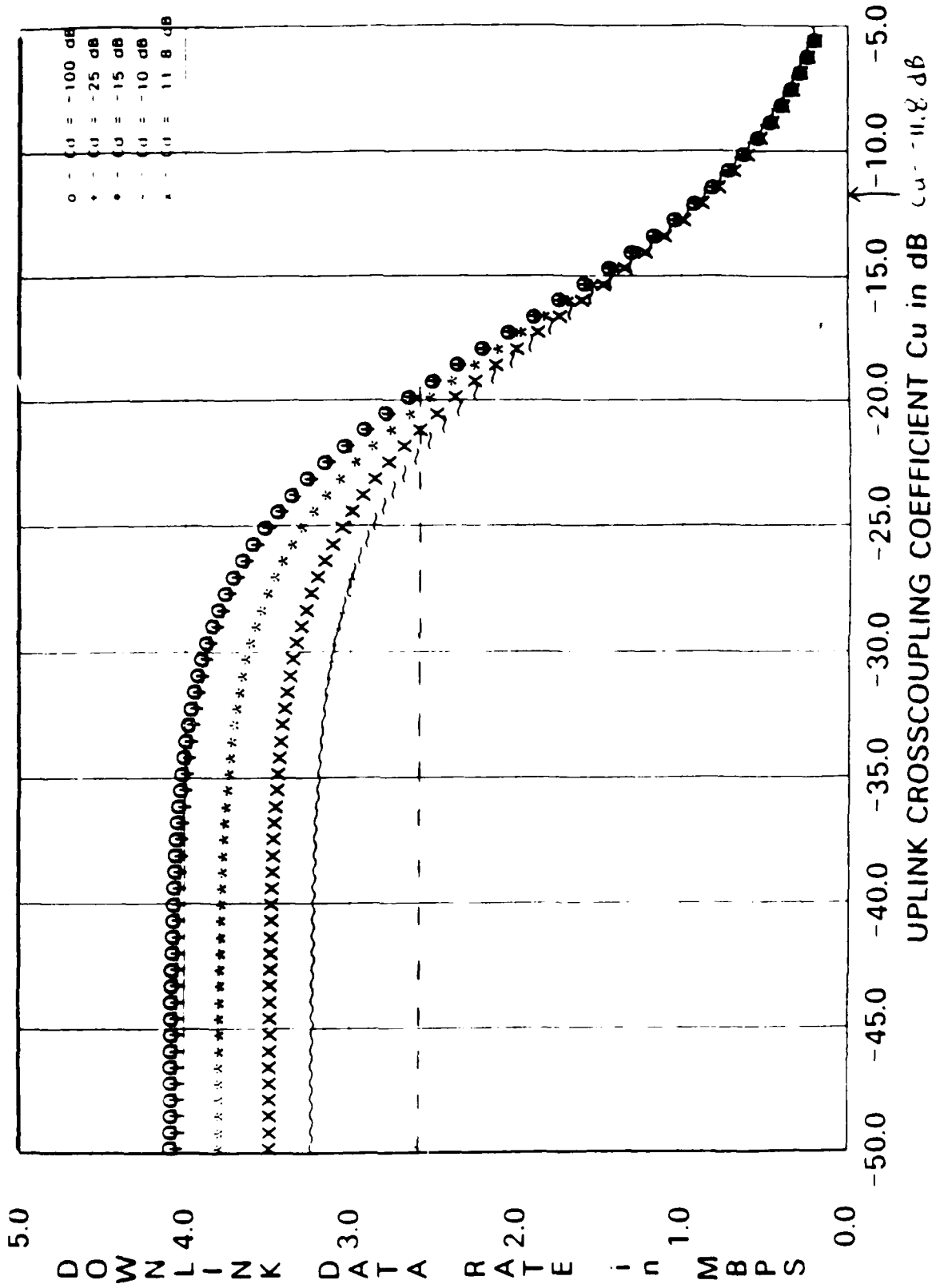

Figure 4-3. Link Data Rate vs. C_u for Scenario 3

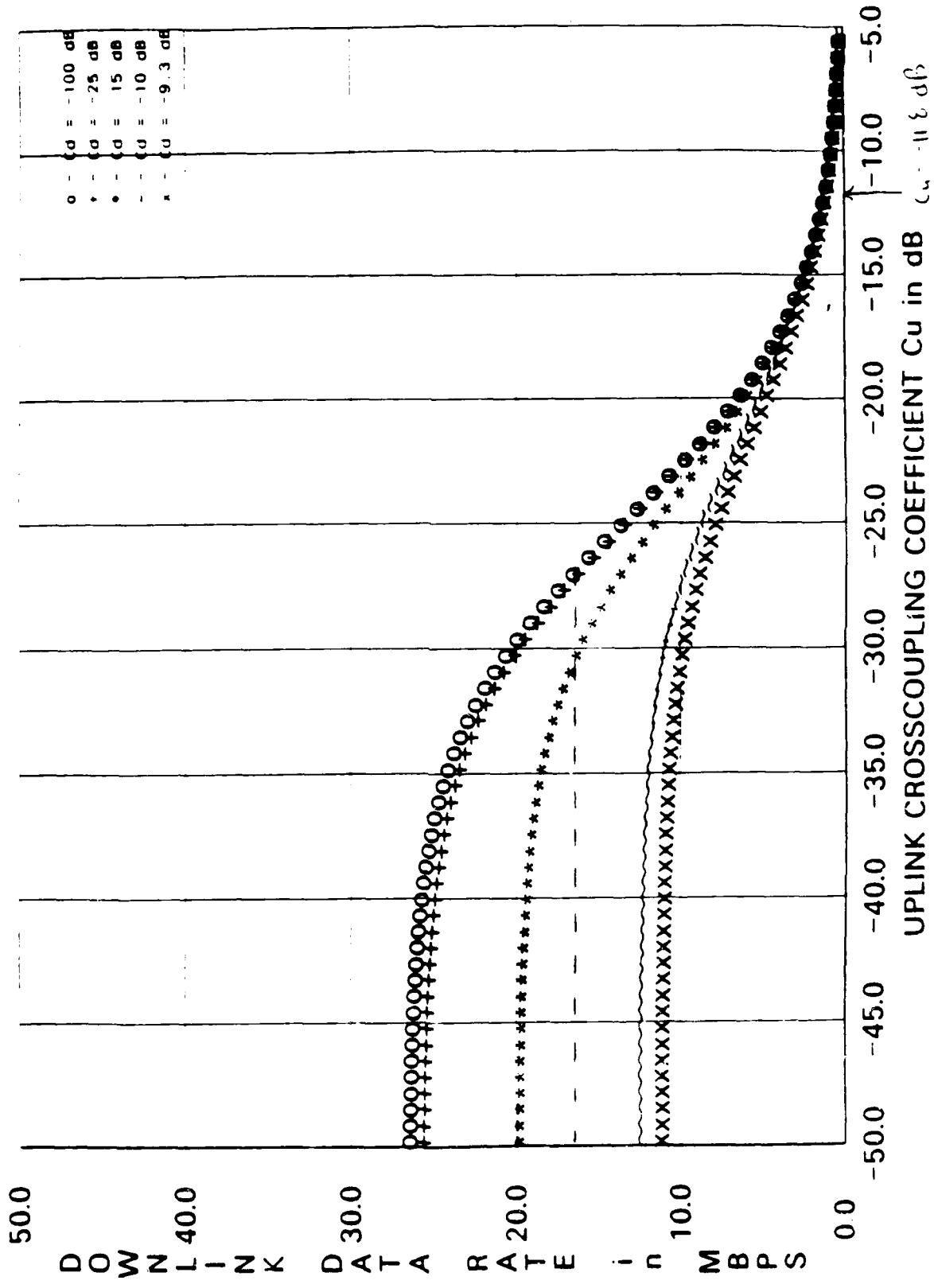

Figure 4-4. Link Data Rate vs C_u for Scenario 4

AD-A174 918

ANALYSIS OF DSCS (DEFENSE SATELLITE COMMUNICATIONS
SYSTEM) III SHF (SUPER (U) M/R-COM GOVERNMENT SYSTEMS
DIV VIENNA VA P G OLIVERI ET AL 01 DEC 86
DCA/MSO-86-109A DCA100-84-C-0009

2/2

UNCLASSIFIED

F/G 17/2

NL

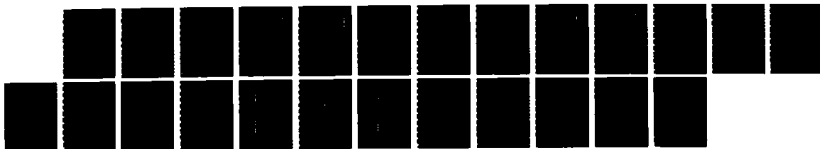

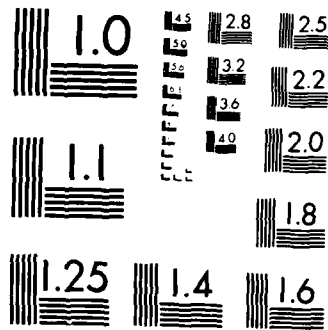

XEROCOPY RESOLUTION TEST CHART
NATIONAL BUREAU OF STANDARDS 1963-A

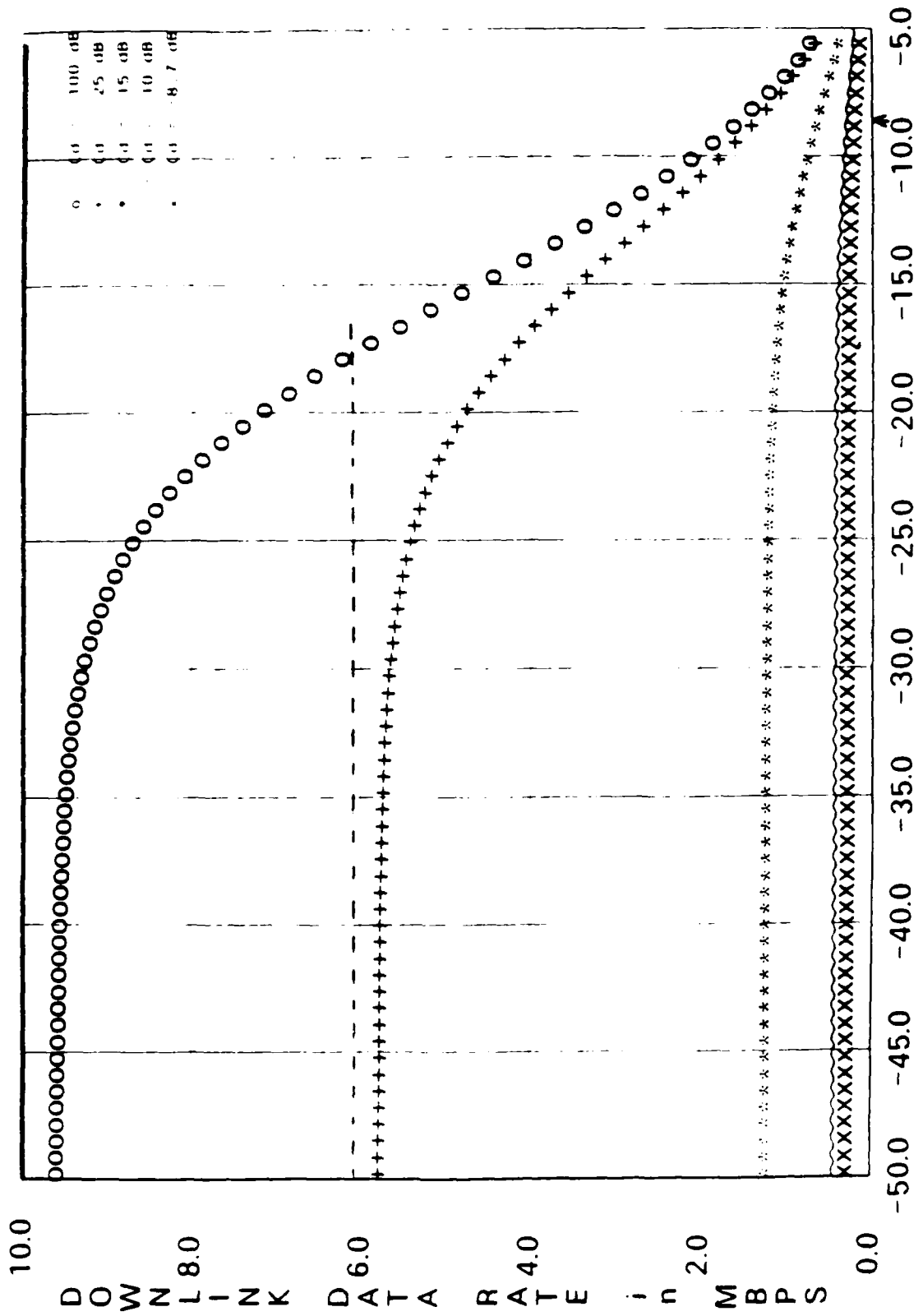

UPLINK CROSSCOUPLING COEFFICIENT C_u in dB

$C_u = 8.7$ dB

Figure 4-5. Link Data Rate vs. C_u for Scenario 5

discussed in Section 3.2, uplink noise received by the cross-polarized channel due to channels 3 and 4 causes the uplink noise to capture a larger percent of transponder power and thus increase the reradiated noise and decrease downlink signal strength. The curves also show that major improvements in antenna axial ratios are needed to improve link performance so that the minimum acceptable link data rate is achieved. For example, in scenario 1, the supportable link data rate without cross-polarized noise interference is 4.1 Mbps. Thus, the minimum acceptable data rate is 2.6 Mbps. (This data rate is shown in Figure 4-1 by the dotted line.) From the curve it can be seen that this requires C_u to be -19 dB or less. However, the axial ratios of the current spacecraft and earth terminals cause C_u to be -11.8 dB, which is 7 dB larger than the required value. The results for scenario 5 (Figure 4-5) show that while both C_u and C_d have an effect on supportable data rate, C_d has the larger impact. This occurs because the desired link is in Channel 4 which has 13 dB less EIRP than the interfering channel (the cross-polarized channel). This result confirms the results shown earlier in Section 3.2 that indicate that a large difference in EIRP between the cross-polarized channels can cause a large decrease in link E_b/N_o .

Scenarios 6 through 9 were developed to analyze the use of a wideband cross-polarized channel placed opposite channels 5 and 6. Figures 4-6 through 4-9 show the supportable data rates for each scenario. The results of these scenarios are similar to the above results for a wideband cross-polarized channel opposite channels 3 and 4. That is, the cross-polarized channel link data rate is limited mainly by inadequate uplink isolation (C_u) while channels 5 and 6 are limited mainly by inadequate downlink isolation (C_d).

Scenarios 10, 11, and 12 were developed to analyze the use of a wideband cross-polarized channel placed opposite channels 1 and 2. Figures 4-10, 4-11, and 4-12 show the supportable

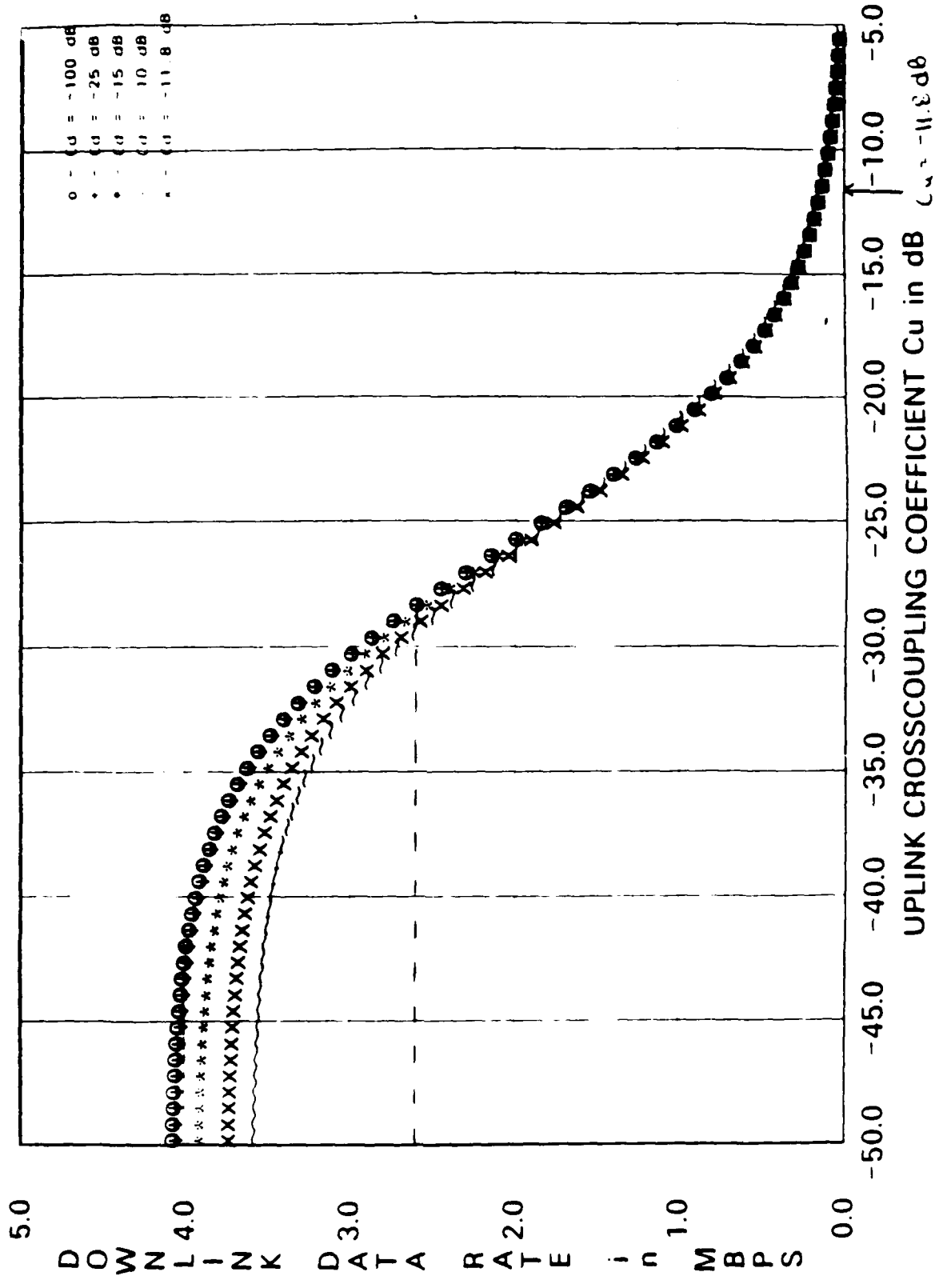

Figure 4-6. Link Data Rate vs. C_u for Scenario 6

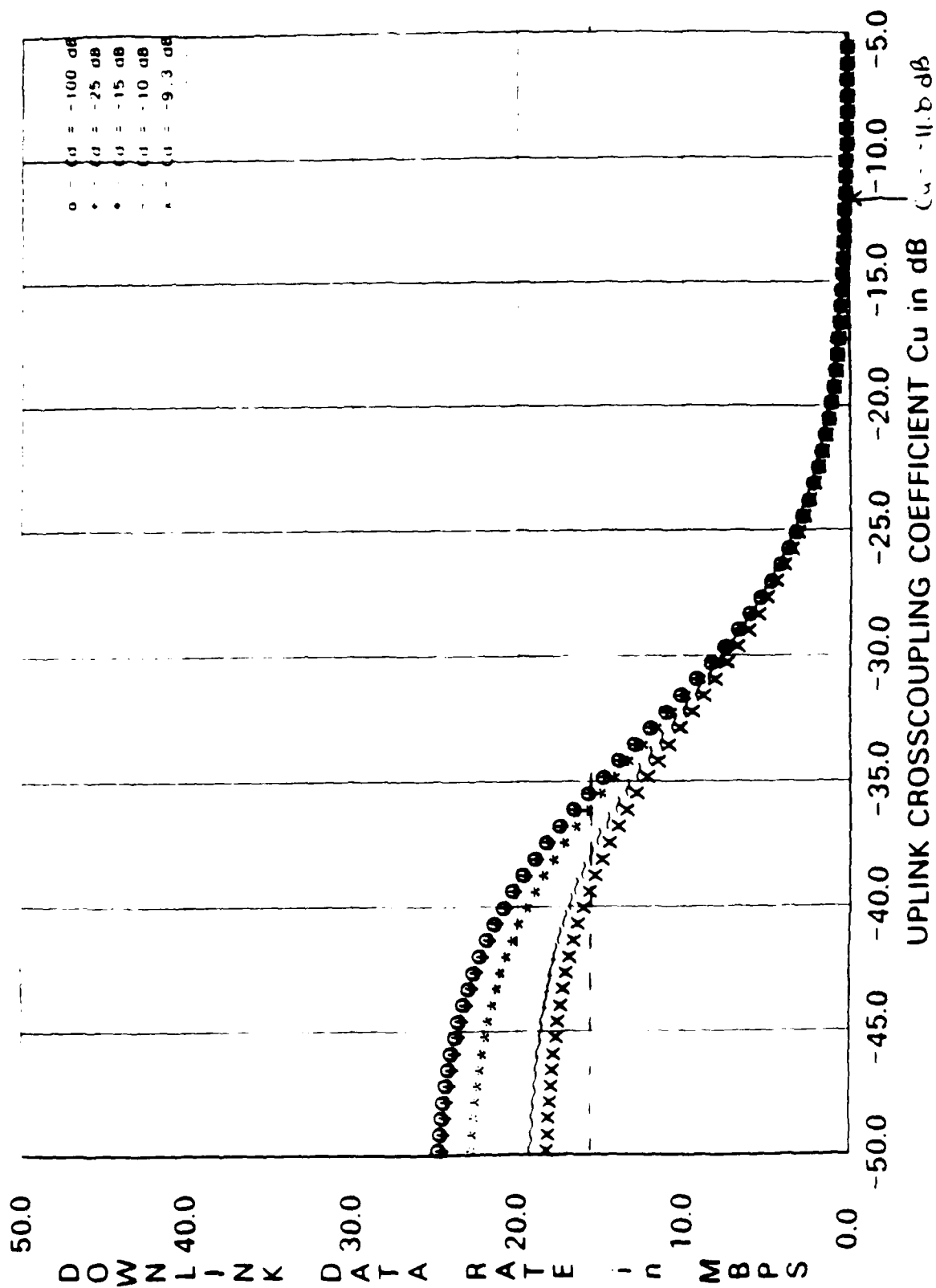

Figure 4-7. Link Data Rate vs. C_u for Scenario 7

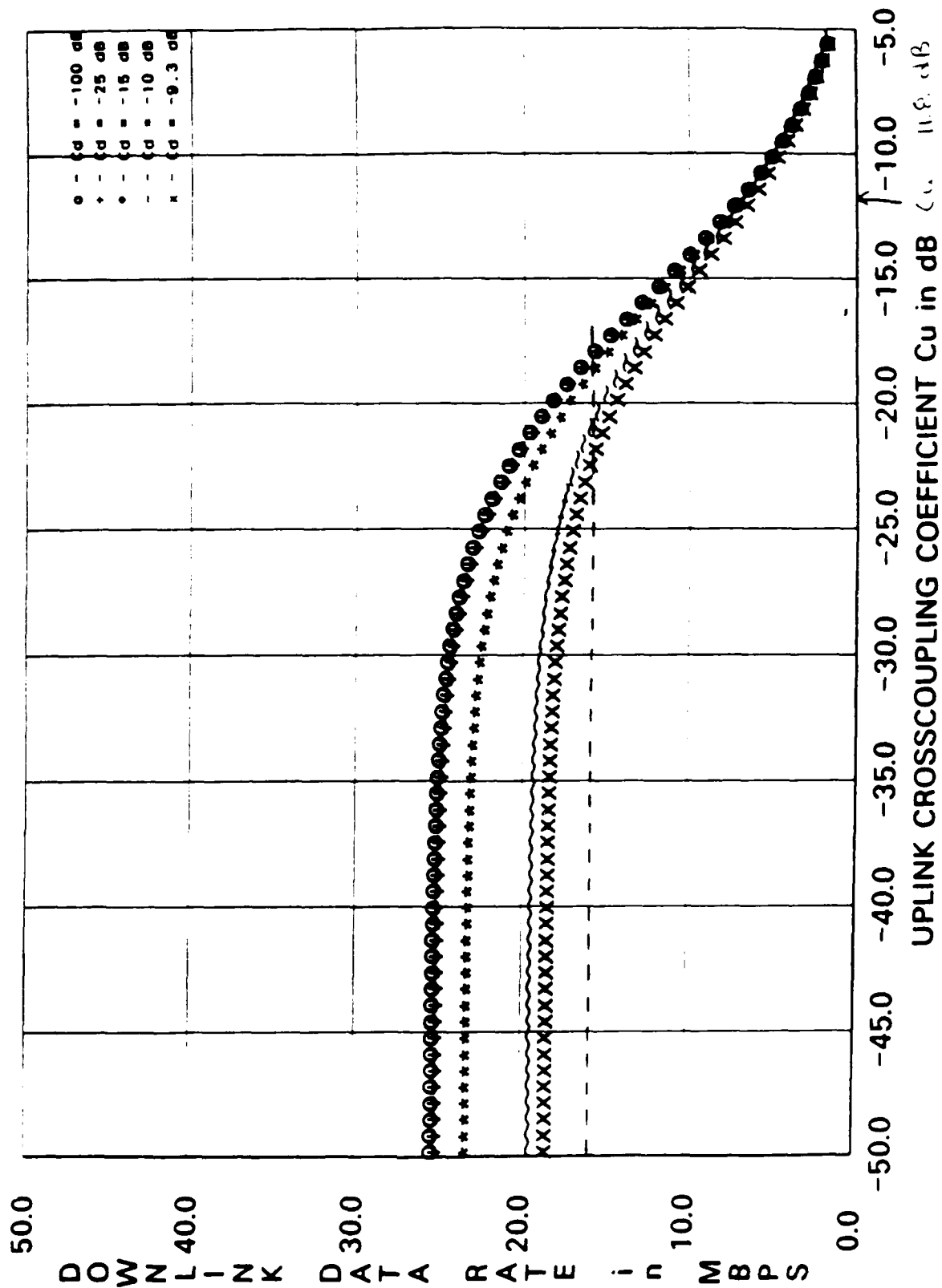

Figure 4-8. Link Data Rate vs. C_u for Scenario 8

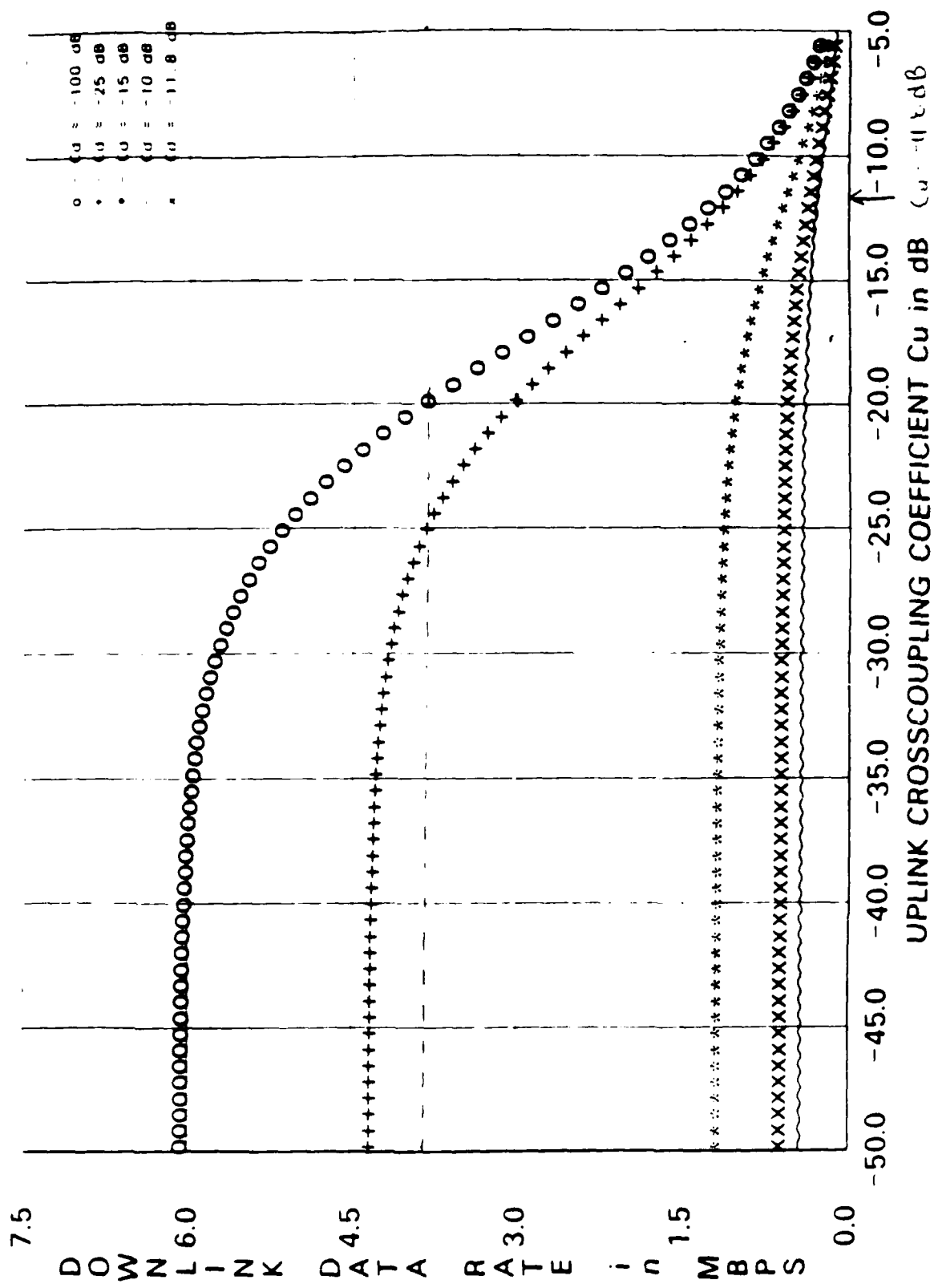

Figure 4-9. Link Data Rate vs. C_u for Scenario 9

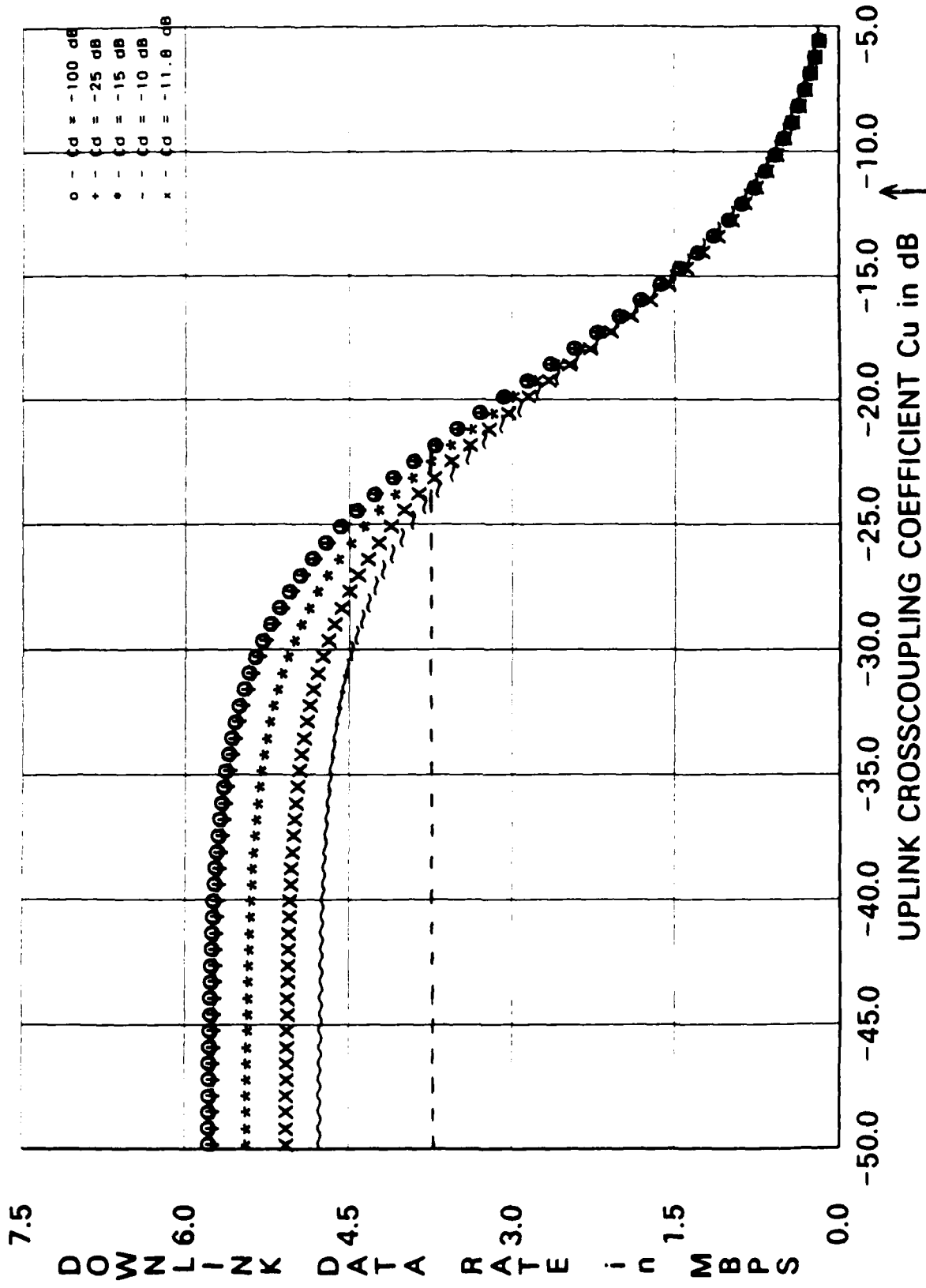

Figure 4-10. Link Data Rate vs. C_u for Scenario 10
 $C_u = 10.9$



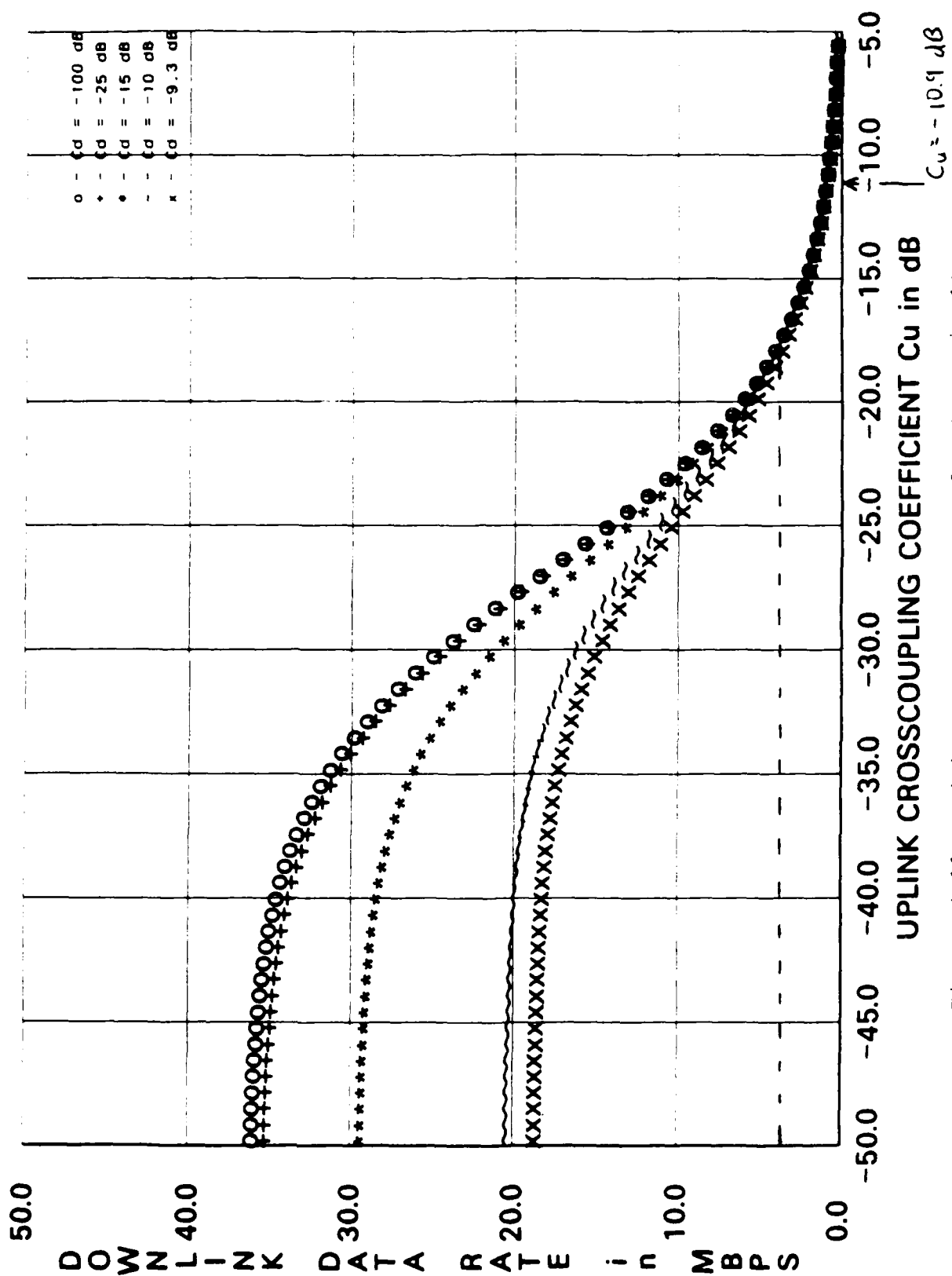

Figure 4-11. Link Data Rate vs. C_u for Scenario 11

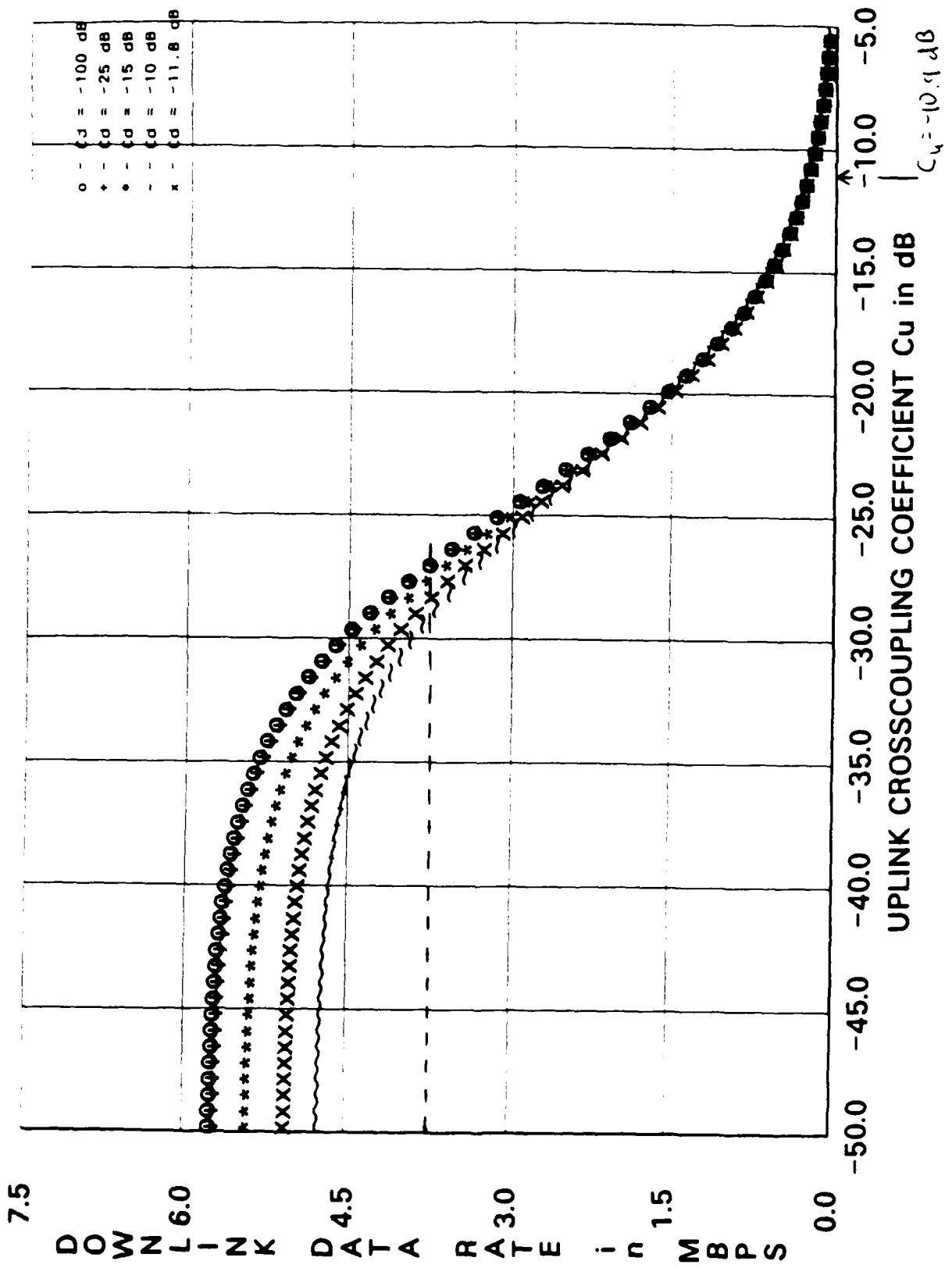

Figure 4-12. Link Data Rate vs. C_u for Scenario 12

link data rates. For the current specified value of axial ratio for both space and ground antennas, a C_u of -10.9 dB is achieved. For this value of C_u , the achievable data rate is 725 kbps to an 8-foot terminal and 920 kbps to a 20-foot terminal. These data rates assume no link margin. GMF links typically have at least 4 dB of link margin. Taking this link margin into account, the achievable data rates decrease to 290 kbps to an 8-foot terminal and 366 kbps to a 20-foot terminal. If the axial ratio of the satellite GDA antenna is improved from 3 dB to 1 dB, a C_u of -15.3 dB is achieved. For $C_u = -15.3$ dB, the achievable data rate to an 8-foot terminal is 1.4 Mbps and 2 Mbps to a 20-foot terminal. Again taking into account a 4-dB link margin, the achievable data rates decrease to 550 kbps to an 8-foot terminal and 800 kbps to a 20-foot terminal.

As stated in Section 3.3, typical data rates for GMF links are between 600 kbps to 1.5 Mbps, with some link data rates as high as 2.5 Mbps. Since the maximum data rate to an 8-foot terminal is only 550 kbps, the required data rates are not supportable by the cross-polarized channel. In order to support a link data rate of 1.5 Mbps, the C_u must be improved to between -18 dB and -28.5 dB.

Table 4-1 summarizes the results for wideband cross-polarized channel scenarios. For placing the wideband cross-polarized channel opposite channels 3 and 4 or channels 5 and 6, Table 4-1a contains the values of C_u and C_d based on the specified values of axial ratio for the satellite and earth terminal antennas, the required C_u and C_d , and the required satellite and earth terminal antenna axial ratios needed to meet the minimum value of required C_u or C_d . The earth terminal axial ratios were based on achieving a 0.5 dB axial ratio on the spacecraft. If a 0.5 dB satellite axial ratio required an earth terminal axial ratio of less than 0.5 dB to meet end-to-end objectives, the equal axial ratios were postulated for both the satellite and earth terminals.

Table 4-1. Summarization of Results for Wideband Cross-Polarized Channel

(a) WIDEBAND CROSS-POLARIZED CHANNEL OPPOSITE CHANNELS 3 AND 4 OR CHANNELS 5 AND 6

SCENARIO	ACTUAL C_u^1 (dB)	ACTUAL C_d^1 (dB)	REQUIRED MAX. C_u^2 (dB)	REQUIRED MAX. C_d^3 (dB)	POSTULATED AXIAL RATIO (IN dB)	
					S/C	ET
1	-11.8	-11.8	-19	-10	0.50	1.45
2	-11.8	-9.3	-25	-10	0.50	0.50
3	-11.8	-11.8	-18	-10	0.50	1.69
4	-11.8	-9.3	-27	-13	0.40	0.40
5	-8.7	-8.7	-10	-25.5	0.46	0.46
6	-11.8	-11.8	-27	-10	0.40	0.40
7	-11.8	-9.3	-35	-10	0.15	0.15
8	-11.8	-9.3	-18	-10	0.50	1.69
9	-11.8	-11.8	-18	-22.5	0.50	0.80

(b) WIDEBAND CROSS-POLARIZED CHANNEL OPPOSITE CHANNELS 1 AND 2

SCENARIO	ACTUAL C_u^1 (dB)	ACTUAL C_d^1 (dB)	SUPPORTABLE DATA RATE ⁴ (kbps)	REQUIRED MAX $C_u^{2,5}$ (dB)	REQUIRED MAX $C_d^{3,5}$ (dB)	POSTULATED AXIAL RATIO (IN dB)	
						S/C	ET
10	-10.9	-11.8	290	-24	-10	0.50	0.60
11	-10.9	-9.3	366	-18.5	-10	0.50	1.57
12	-10.9	-11.8	260	-28.5	-10	0.33	0.33

5101300

¹ ASSUMES SPECIFIED VALUES OF AXIAL RATIO FOR CURRENT EARTH TERMINAL AND SATELLITE ANTENNAS

² ASSUMES PERFECT DOWNLINK ($C_d = -\infty$)

³ ASSUMES PERFECT UPLINK ($C_u = -\infty$)

⁴ ASSUMES 4-dB LINK MARGIN

⁵ TO ACHIEVE LINK DATA RATE OF 1.5 Mbps

For placing the wideband cross-polarized channel opposite channels 1 and 2, Table 4-1b contains the C_u and C_d based on the specified values of axial ratio for the satellite and earth terminal antennas. For these current values of C , the table shows the supportable link data rate. The next two columns show the required C_u and C_d needed to achieve a link data rate of 1.5 Mbps. The last two columns show the required satellite and earth terminal antenna axial ratios needed to meet the minimum value of required C_u or C_d .

Table 4-1 shows that the required end-to-end isolation (C) range from -18 dB to -35 dB, while the actual isolation values (of C) achievable with the current earth terminal and spacecraft antennas range from -8.7 dB to -11.8 dB. The table also shows that in order to achieve the required value of end-to-end isolation (C), the axial ratios of the satellite and earth terminal antennas must be greatly improved. In addition, the required axial ratios were calculated assuming no rain. To meet objectives for a 99.9 percent link availability, rain polarization compensators would be required to obtain the required values of C . Without compensators, the value of C increases to -15 dB even if both the satellite and earth terminal have axial ratios of 0 dB, thus resulting in less than 1-dB performance improvement objective.

4.2 NARROWBAND CROSS-POLARIZED CHANNEL

Six scenarios were developed to analyze the use of a narrowband cross-polarized channel. Scenarios 13, 14, and 15 assumed a 25-MHz bandwidth for the cross-polarized channel while scenarios 16, 17, and 18 are the same scenarios except that the cross-polarized channel bandwidth is reduced by 15 MHz.

Two benefits result in placing the cross-polarized channel opposite the guardband. The first benefit is to increase the polarization isolation on the uplink. This is due to the

attenuation of the cross-polarized interference signals by the satellite channel filters. For a 25-MHz cross-polarized channel this benefit is an extra 7.6 dB of isolation. For the 15-MHz cross-polarized channel, the channel filters increase the isolation by 15.4 dB. On the downlink, the Spectrum Efficient Network Unit (SENU) filters at the receive DSCS earth terminal attenuate the cross-polarization noise by 25 dB, thereby improving the downlink cross-polarization isolation by 25 dB.

Figures 4-13 through 4-18 show the supportable link data rates for the six scenarios. The C_u and C_d values are due only to the axial ratios of the receive and transmit antennas (e.g., the curves already take into account the attenuation of cross-polarized noise by the satellite channel filters and the earth terminals SENU filters). The curves show that due to the SENU filters, the downlink cross-coupling coefficient, because of the antenna axial ratios, has virtually no effect on data link. That is, any degradation due to cross-polarization interference is due to the uplink cross-coupling coefficient (C_u).

Figures 4-13, 4-14, and 4-15 show the results for the 25-MHz channel. The results show that even with the current axial ratio values for the satellite and earth terminals antennas, satisfactory performance is achieved for links in the cross-polarized channel and links in channel 1. However, the link in channel 6 does not meet the performance criteria. In order to meet the required equivalent isolation (C_u of -16 dB), the axial ratio of satellite ECH must be improved from 2.5 dB to 0.75 dB. Figures 4-16, 4-17, and 4-18 show the results for the 15-MHz channel. These figures show that all the channels achieve satisfactory performance even with the current axial ratio values for the satellite and earth terminals.

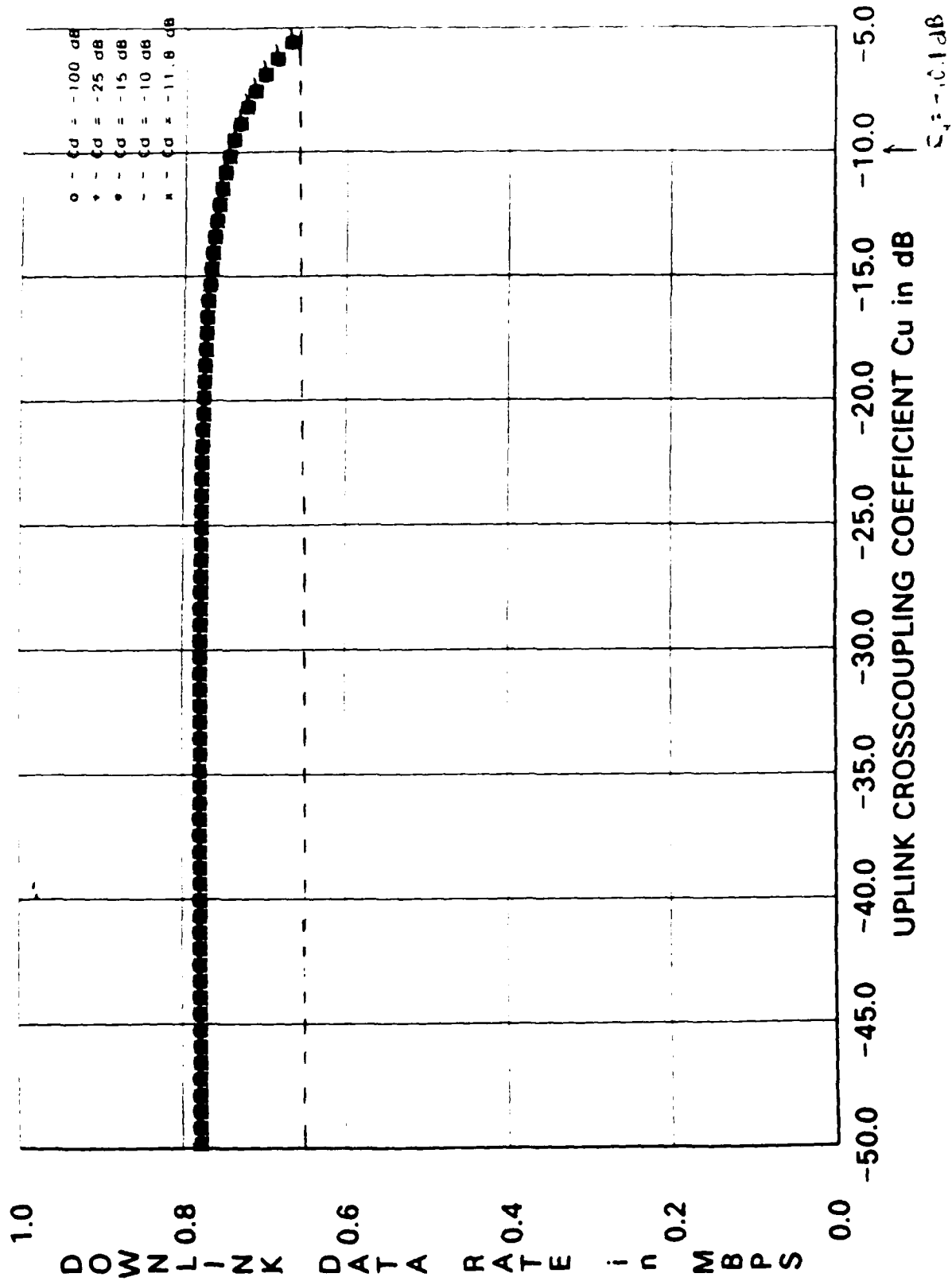

Figure 4-13. Link Data Rate vs. C_u for Scenario 13

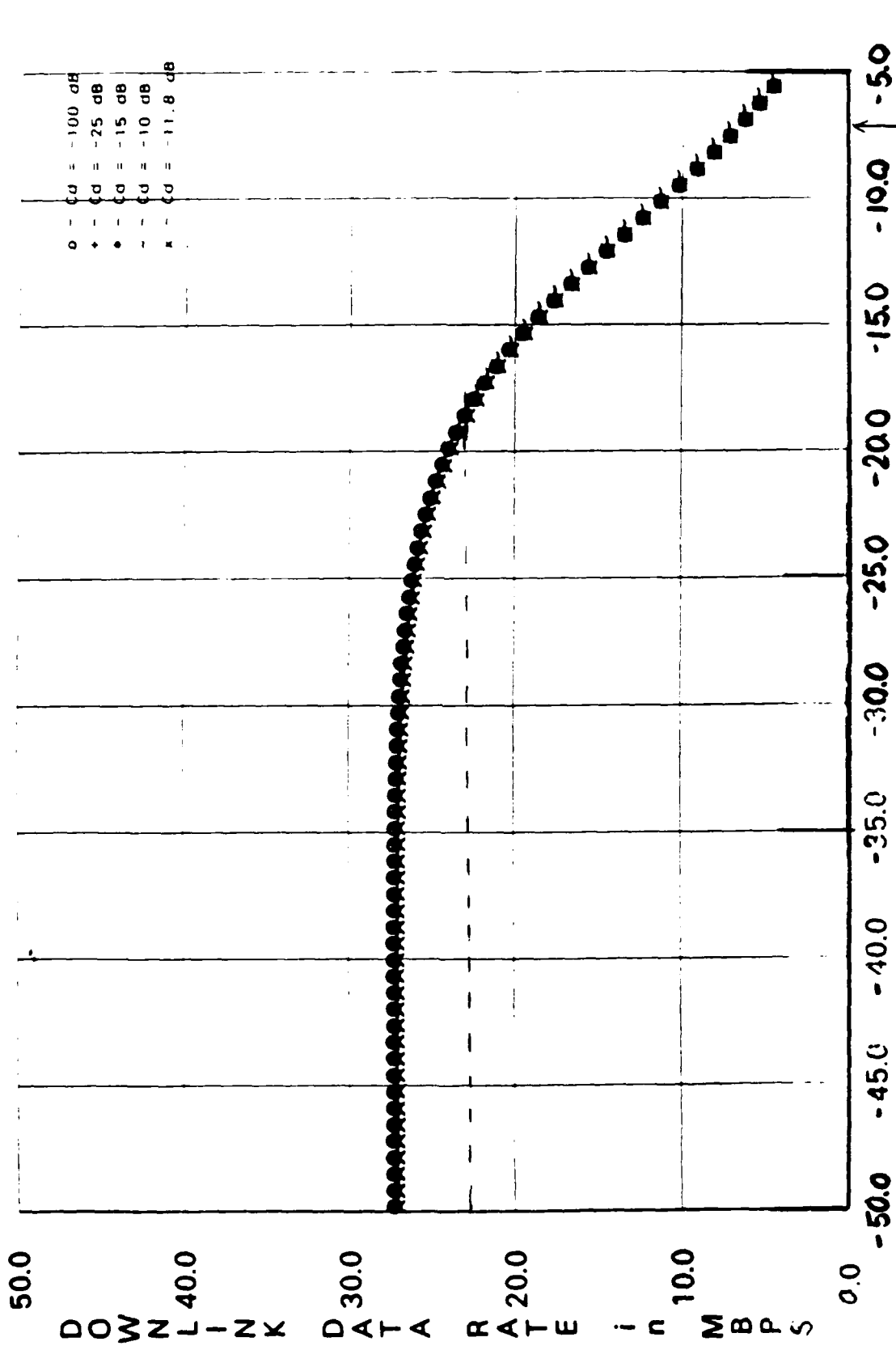

Figure 4-14. Link Data Rate vs. C_u for Scenario 14

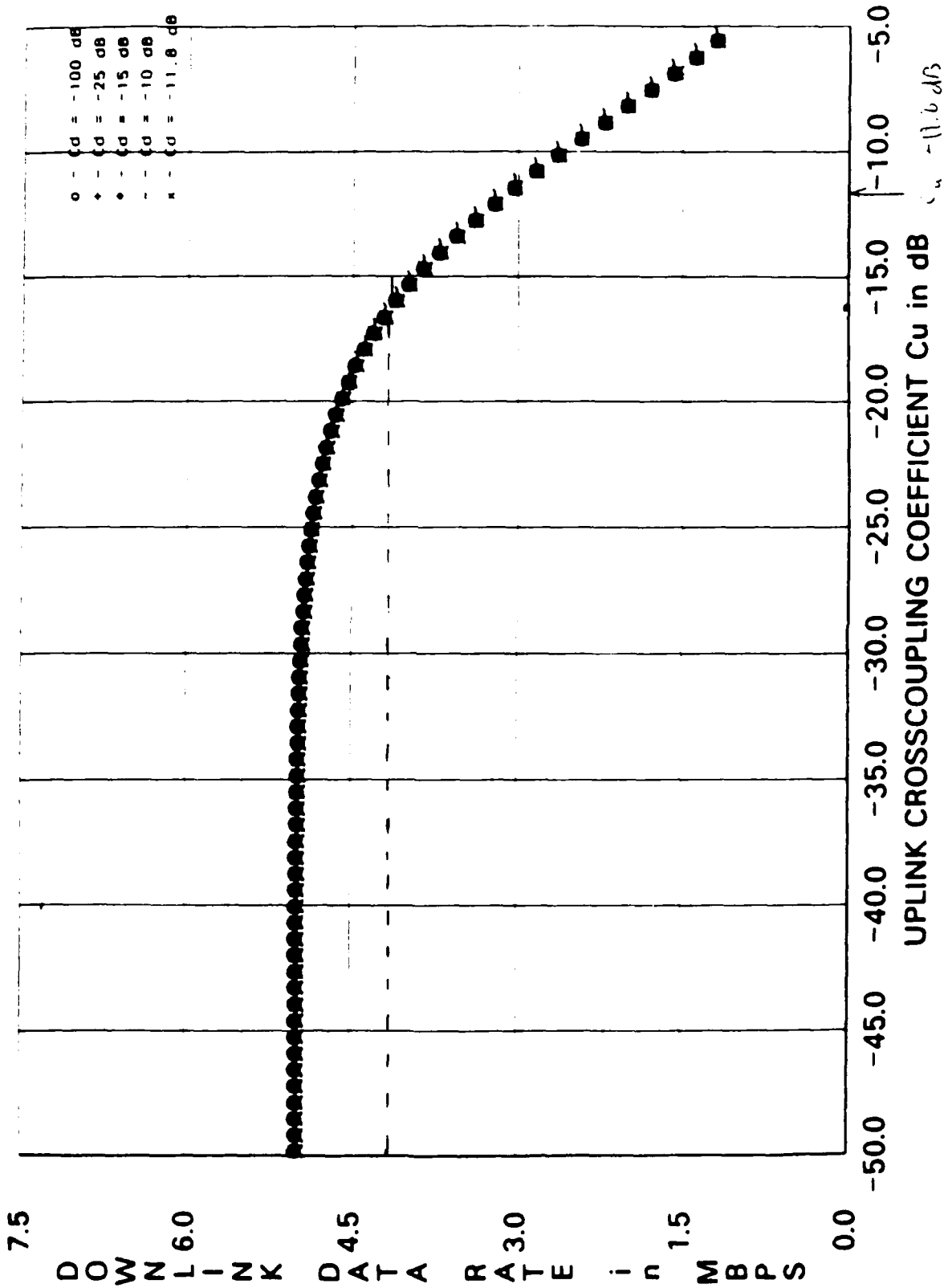

Figure 4-15. Link Data Rate vs. C_u for Scenario 15

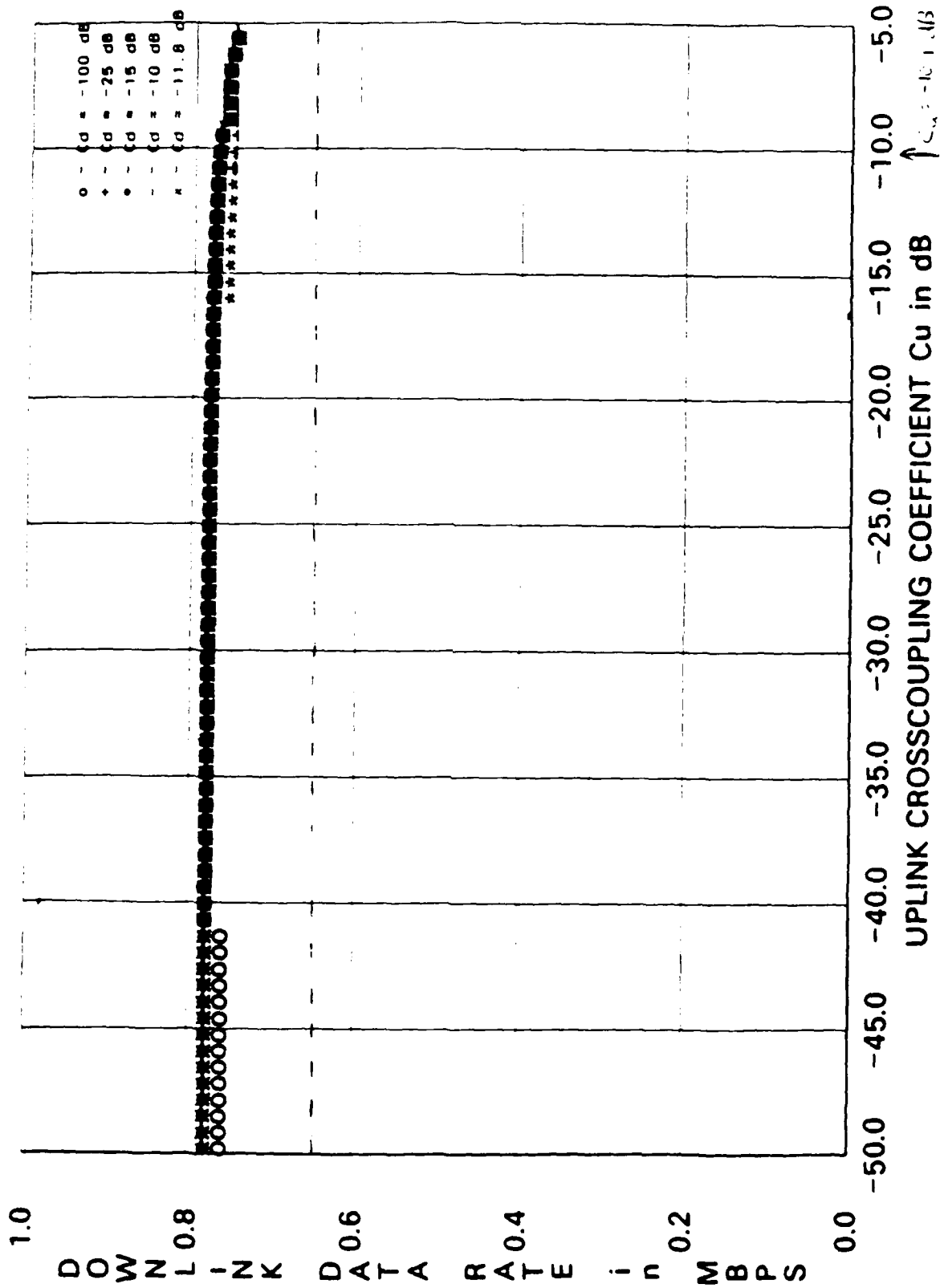

Figure 4-16. Link Data Rate vs. C_u for Scenario 16

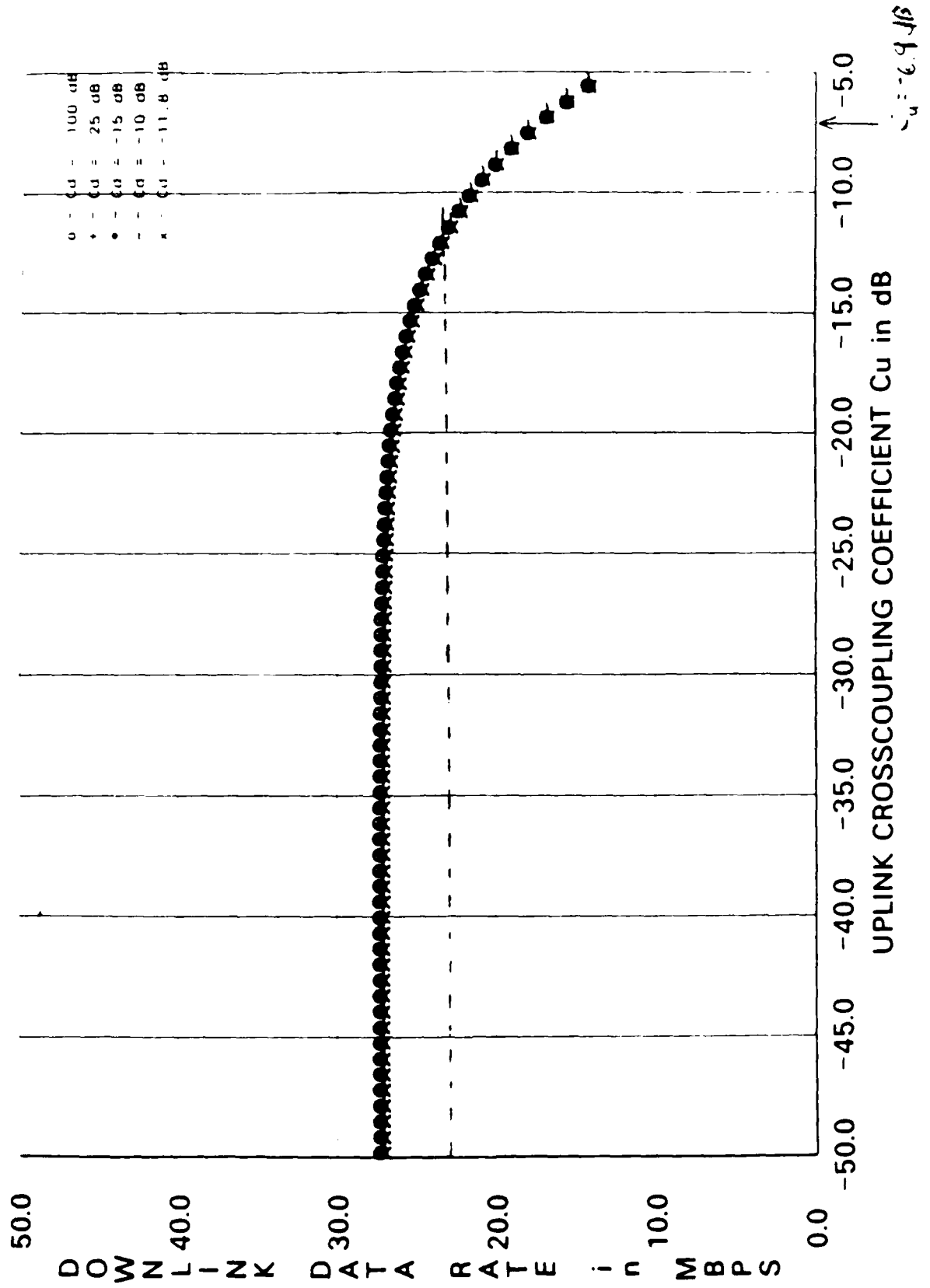

Figure 4-17. Link Data Rate vs. C_u for Scenario 17

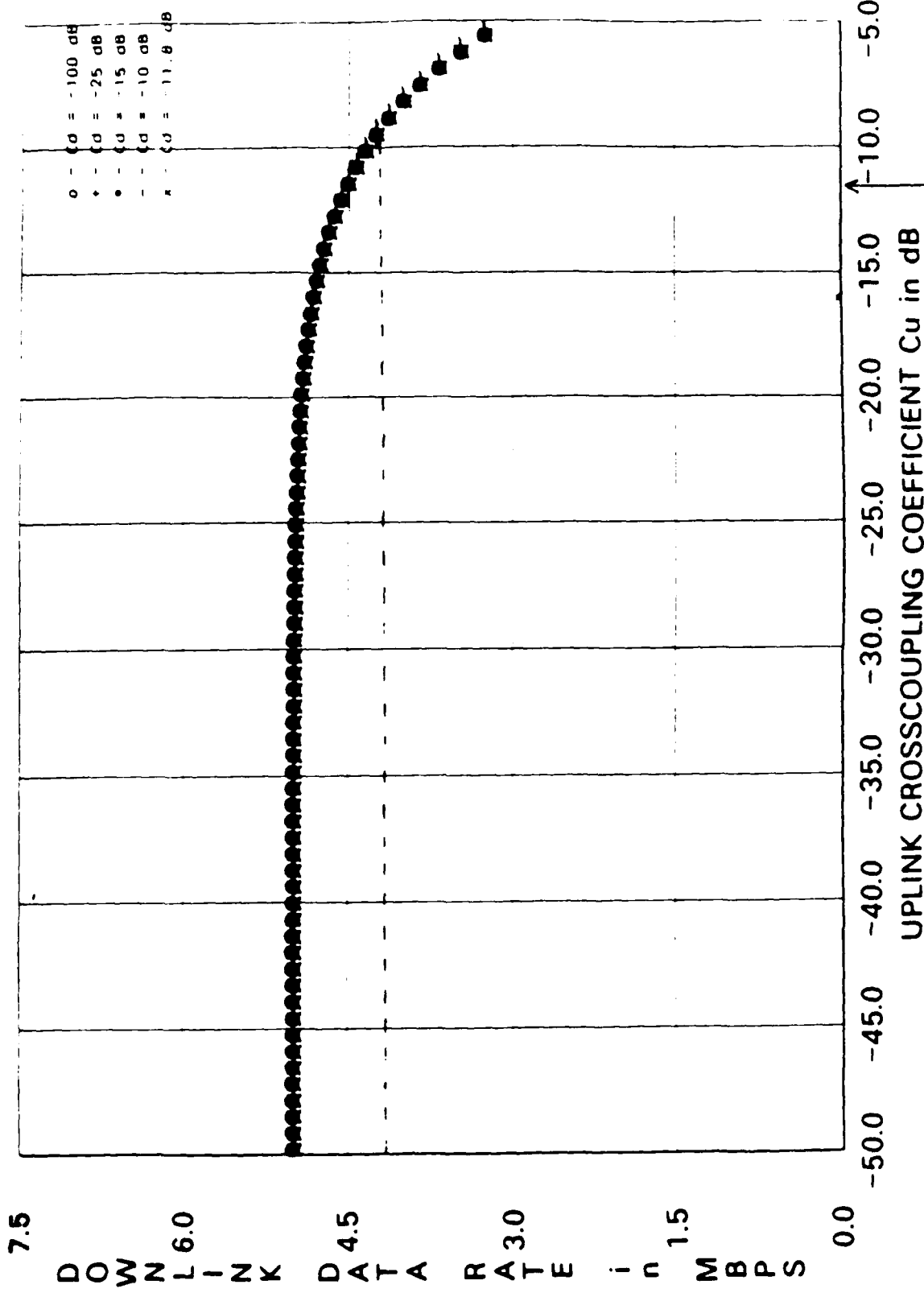

Figure 4-18. Link Data Rate vs. C_u for Scenario 18

CHAPTER 5 CONCLUSIONS AND RECOMMENDATIONS

Examining the results presented in the previous chapter the following conclusions can be drawn. In order to implement a wideband (75- to 100-MHz) cross-polarized channel for use by the GMF community, link polarization isolations of at least 25 dB must be achieved. This would require the axial ratios for all spacecraft and earth terminals to be improved to 0.5 dB. In addition, to meet the current objective of 99.9 percent link availability, polarization compensators must be installed at the earth terminals. Since these improvements must be made to many terminals (approximately 400), it is recommended that a wideband cross-polarized channel not be implemented.

In contrast, results show that it is possible to implement a narrowband cross-polarized channel placed opposite the 25-MHz guardband between channels 1 and 6 on the uplink and channels 5 and 6 on the downlink. If the bandwidth of the narrowband channel is 15 MHz, then no improvement in spacecraft and earth terminal antennas would be needed. If the bandwidth of the narrowband channel is 25 MHz, then the axial ratio of the spacecraft ECHs would have to be reduced to a least 0.75 dB; however, earth terminal axial ratios would not have to be improved.

Recently, tests have been performed using the 38-foot GSC-52 and 8-foot GSC-49 terminals to determine link cross-coupling coefficients (C). Results showed that C ranged from -25 to -30 dB for the GSC-52 terminal and from -20 to -25 dB for the GSC-49 terminal. This would indicate that the axial ratios of both the satellite and earther terminals were substantially better than their specification values. Also, the values of C obtained in the test are close to the values that analysis showed is needed to achieve the required throughputs. However, two points must be made. First, the

tests were performed in clear weather and second, they were performed on only two terminals. Further tests are needed to determine if all terminals will perform this much better than their specified values. If additional testing indicates that most terminals perform much better than their specifications would indicate, then the results developed in this report should be reexamined to determine the feasibility of the wideband cross-polarized channel case that were not considered feasible here without major terminal and space segment upgrades.

Another potential configuration would be to place the wideband cross-polarized channel opposite channel 2. The cross-polarized channel would use a duplexed GDA and would be used to support a second GMF deployment in a satellite area. Although this configuration merits further examination, it was not examined in this study because the primary objective of this study was to provide channel 2 bandwidth resources to ECCM users while simultaneously providing the GMF community with spacecraft resources equal to or better than their current channel 2 resource. Other alternatives for cross-polarized system use could be considered depending on the system architecture objective.

REFERENCES

1. Johnson, Richard C.; Jasik, Henry. Antenna Engineering Handbook. New York: McGraw-Hill; 1984.
2. DCA/MSO, DSCS/Wideband SHF Enhancements and EHF Antenna Recommendations for the Mid- (1986-1991) and Far-Term (1992-2000) Periods (U), prepared under contract DCA100-84-C-0009 by M/A-COM LINKABIT, Inc., Report No. MSO-85-114a, November 1985 (Unclassified).
3. D. E. DiFonzo, A. E. Williams, and W. S. Trachtman, "Adaptive Polarization Control for Satellite Frequency Reuse Systems," Int. Symposium of IEEE AP-S Digest, pp. 208-212, 1975.
4. W. L. Stutzman, D. L. Runyon, and C. W. Bostian, "Data Analysis for Dual-Polarized Communication Link Experiments," IEEE Transactions on Antennas and Propagation, vol. AP-31, No. 6, page 989, November 1983.
5. M. Yamada, H. Yuki, and K. Inagaki, "Compensation Techniques for Rain Depolarization in Satellite Communications," Radio Science, vol. 17 (No. 5), pp. 1220-1230, Sept.-Oct. 1982.
6. T. S. Chu, "Restoring the Orthogonality of Two Polarizations in Radio Communications Systems, I," Bell Systems Technical Journal, Vol. 50 (No. 9), November, 1971.
7. A. J. Gionatasio, "Broadband Adaptively Controlled Polarization - Separation Networks," 7th European Microwave Conference Proceedings, Copenhagen, September, 1977.
8. R. R. Persinger, R. W. Grunner, J. E. Effland, D. F. DiFonzo, "Operational Measurements of a 4/6-GHz Adaptive Polarization Compensation Network Employing Up/Downlink Correlation Algorithms", IEEE Conf. Publ., Part 2, 181-187.
9. A. S. Rosenbaum, "Binary PSK Error Probabilities with Multiple Cochannel Interferences," IEEE Trans. on Communications, Vol COM-18, No. 6, June 1970.
10. DCA/MSO, DSCS III SHF Enhancements (U) prepared under contract DCA100-84-C-0009 by M/A-COM Government Systems, Inc., Report No. MSO-86-058, May 1986 (Unclassified).

UNCLASSIFIED

SECURITY CLASSIFICATION OF THIS PAGE

REPORT DOCUMENTATION PAGE

Form Approved
OMB No. 0704-0188
Exp Date Jun 30 1986

1a. REPORT SECURITY CLASSIFICATION Unclassified		1b. RESTRICTIVE MARKINGS		
2a. SECURITY CLASSIFICATION AUTHORITY N/A		3. DISTRIBUTION/AVAILABILITY OF REPORT		
2b. DECLASSIFICATION/DOWNGRADING SCHEDULE N/A				
4. PERFORMING ORGANIZATION REPORT NUMBER(S) MSO-86-109a		5. MONITORING ORGANIZATION REPORT NUMBER(S)		
6a. NAME OF PERFORMING ORGANIZATION M/A-COM Government Systems, Inc	6b. OFFICE SYMBOL (If applicable)	7a. NAME OF MONITORING ORGANIZATION Defense Communications Agency MILSATCOM Systems Office, Code A800		
6c. ADDRESS (City, State, and ZIP Code) 8619 Westwood Center Drive Vienna, VA 22180		7b. ADDRESS (City, State, and ZIP Code) Washington, D.C. 20305-2000		
8a. NAME OF FUNDING/SPONSORING ORGANIZATION Defense Communications Agency	8b. OFFICE SYMBOL (If applicable) A800	9. PROCUREMENT INSTRUMENT IDENTIFICATION NUMBER		
8c. ADDRESS (City, State, and ZIP Code) 5th & S. Courthouse Road Arlington, VA 22204		10. SOURCE OF FUNDING NUMBERS		
		PROGRAM ELEMENT NO	PROJECT NO	TASK NO
11. TITLE (Include Security Classification) Analysis of DSCS III SHF Upgrades (U), Volume I				
12. PERSONAL AUTHOR(S) P.G. Oliveri, D.R. Avers				
13a. TYPE OF REPORT Final	13b. TIME COVERED FROM 7/10/86 TO 11/30/86	14. DATE OF REPORT (Year, Month, Day) 1986 December 1	15. PAGE COUNT 117	
16. SUPPLEMENTARY NOTATION				
17. COSAT CODES		18. SUBJECT TERMS (Continue on reverse if necessary and identify by block number) DSCS III, Cross-Coupling Coefficient, Dual-Polarized Signals, Polarization Trackers, Axial Ratios, Antennas		
FIELD	GROUP			SUB-GROUP
19. ABSTRACT (Continue on reverse if necessary and identify by block number) (U) This report analyzes potential SHF upgrades to the DSCS III system. It is published in three volumes. This volume analyzes the effects of frequency reuse via polarization diversity on the DSCS system. This report describes the necessary improvements to both the space and ground segment needed to use dual-polarized signals in the DSCS system. The results of the study show that a 75- to 100-MHz cross-polarized channel would require major upgrades to both space and ground segments. A 15- to 25-MHz cross-polarized channel placed opposite a guardband would require only small improvements to the space and ground segments.				
20. DISTRIBUTION/AVAILABILITY OF ABSTRACT <input checked="" type="checkbox"/> UNCLASSIFIED/UNLIMITED <input type="checkbox"/> SAME AS RPT <input type="checkbox"/> DTIC USERS		21. ABSTRACT SECURITY CLASSIFICATION Unclassified		
22a. NAME OF RESPONSIBLE INDIVIDUAL Lt. Col. A. L. Morse		22b. TELEPHONE (Include Area Code) (202) 692-0281	22c. OFFICE SYMBOL A820	

DD FORM 1473, 84 MAR

83 APR edition may be used until exhausted
All other editions are obsolete.

SECURITY CLASSIFICATION OF THIS PAGE

UNCLASSIFIED

END

1-87

DTIC