

AD-A173 375

SELECTIVE WITHDRAWAL RISER FOR CAVE RUN LAKE(U) ARMY
ENGINEER WATERWAYS EXPERIMENT STATION VICKSBURG MS
HYDRAULICS LAB S T MAYNORD ET AL. NOV 86
WES/TR/HL-86-9

1/1

UNCLASSIFIED

F/G 13/2

NL

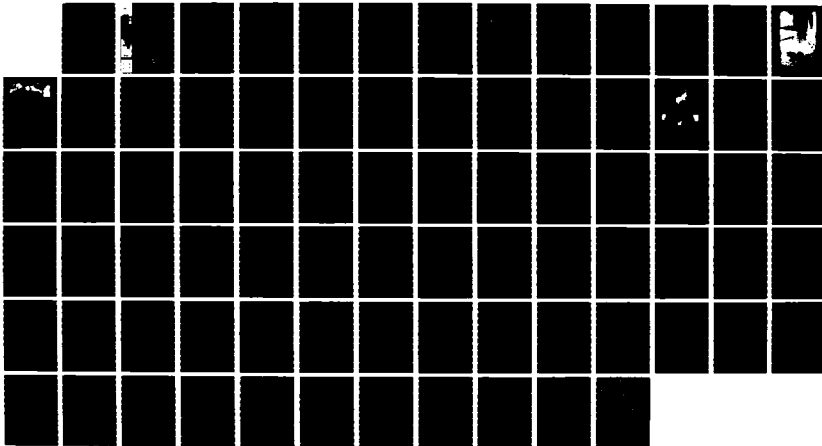

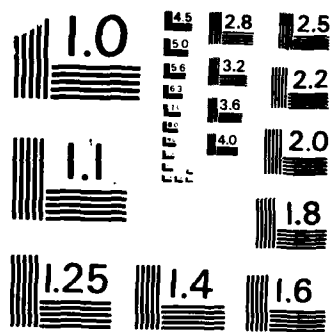

MICROCOPY RESOLUTION TEST CHART
NATIONAL BUREAU OF STANDARDS-1963-A

TECHNICAL REPORT HL-86-9

12

SELECTIVE WITHDRAWAL RISER FOR CAVE RUN LAKE

by

Stephen T. Maynard, Charles H. Tate, Jr.

Hydraulics Laboratory

DEPARTMENT OF THE ARMY
Waterways Experiment Station, Corps of Engineers
PO Box 631, Vicksburg, Mississippi 39180-0631



US Army Corps
of Engineers

AD-A175 375

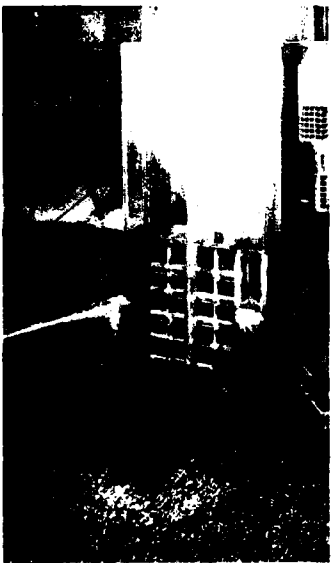

November 1986

Final Report

Approved For Public Release; Distribution Unlimited

DTIC
S DEC 29 1986
E

DTIC FILE COPY

Prepared for US Army Engineer District, Louisville
Louisville, Kentucky 40201-0059

86 12

HYDRAULICS
LABORATORY

Destroy this report when no longer needed. Do not return
it to the originator.

The findings in this report are not to be construed as an official
Department of the Army position unless so designated
by other authorized documents.

The contents of this report are not to be used for
advertising, publication, or promotional purposes.
Citation of trade names does not constitute an
official endorsement or approval of the use of
such commercial products.

Unclassified

SECURITY CLASSIFICATION OF THIS PAGE

REPORT DOCUMENTATION PAGE				Form Approved OMB No 0704-0188 Exp Date Jun 30, 1986	
1a REPORT SECURITY CLASSIFICATION Unclassified		1b RESTRICTIVE MARKINGS			
2a SECURITY CLASSIFICATION AUTHORITY		3 DISTRIBUTION/AVAILABILITY OF REPORT Approved for public release; distribution unlimited.			
2b DECLASSIFICATION/DOWNGRADING SCHEDULE					
4 PERFORMING ORGANIZATION REPORT NUMBER(S) Technical Report HL-86-9		5 MONITORING ORGANIZATION REPORT NUMBER(S)			
6a NAME OF PERFORMING ORGANIZATION USAEWES Hydraulics Laboratory		6b OFFICE SYMBOL (If applicable) WESHS	7a NAME OF MONITORING ORGANIZATION		
6c ADDRESS (City, State, and ZIP Code) PO Box 631 Vicksburg, MS 39180-0631		7b ADDRESS (City, State, and ZIP Code)			
8a. NAME OF FUNDING/SPONSORING ORGANIZATION USAED, Louisville		8b OFFICE SYMBOL (If applicable)	9 PROCUREMENT INSTRUMENT IDENTIFICATION NUMBER		
8c. ADDRESS (City, State, and ZIP Code) PO Box 59 Louisville, KY 40201-0059		10 SOURCE OF FUNDING NUMBERS			
		PROGRAM ELEMENT NO	PROJECT NO	TASK NO	WORK UNIT ACCESSION NO
11 TITLE (Include Security Classification) Selective Withdrawal Riser for Cave Run Lake					
12 PERSONAL AUTHOR(S) Maynard, Stephen T., Tate, Charles H., Jr.					
13a TYPE OF REPORT Final report		13b TIME COVERED FROM _____ TO _____	14 DATE OF REPORT (Year, Month, Day) November 1986	15 PAGE COUNT 75	
16 SUPPLEMENTARY NOTATION Available from National Technical Information Service, 5285 Port Royal Road, Springfield, VA 22161.					
17 COSATI CODES		18 SUBJECT TERMS (Continue on reverse if necessary and identify by block number)			
FIELD	GROUP	SUB-GROUP	Cave Run Lake Hydraulic Hydraulic models		
19 ABSTRACT (Continue on reverse if necessary and identify by block number) Tests were conducted to determine the hydraulic and selective withdrawal characteristics of the proposed selective withdrawal riser for Cave Run Lake. A 1:18-scale model was used to investigate the hydraulic performance of the proposed add-on riser. Upper limits for satisfactory riser operation were found to depend on (a) submerged orifice flow, (b) adverse pressures, (c) turbulence within the riser, (d) pool or flow control oscillation, and (e) vortices. Pressures within the proposed riser were positive for all discharges up to 2,500 cfs, indicating that adverse pressure conditions will not have as significant an effect on riser discharge as will the other factors. Performance of the stilling basin for single gate operation was evaluated. Selective withdrawal studies were conducted in a 1:41.1-scale model. Various density profiles were used to study the withdrawal patterns of the proposed riser for different operating regimes. The top riser port nearest the embankment was found to have essentially the same selective withdrawal characteristics as the other ports. ←					
20 DISTRIBUTION/AVAILABILITY OF ABSTRACT <input checked="" type="checkbox"/> UNCLASSIFIED/UNLIMITED <input type="checkbox"/> SAME AS RPT <input type="checkbox"/> DTIC USERS			21 ABSTRACT SECURITY CLASSIFICATION Unclassified		
22a NAME OF RESPONSIBLE INDIVIDUAL			22b TELEPHONE (Include Area Code)	22c OFFICE SYMBOL	

DD FORM 1473, 84 MAR

83 APR edition may be used until exhausted
All other editions are obsolete

SECURITY CLASSIFICATION OF THIS PAGE

Unclassified

PREFACE

The model investigation reported herein was authorized by the Office, Chief of Engineers, US Army, on 24 September 1980, at the request of the US Army Engineer District, Louisville (ORL). The studies were conducted by personnel of the Hydraulics Laboratory, US Army Engineer Waterways Experiment Station (WES), during the period November 1980 to September 1982 under the general supervision of Messrs. H. B. Simmons and F. A. Herrmann, Jr., former and present Chiefs of the Hydraulics Laboratory, respectively, and J. L. Grace, Jr., Chief of the Hydraulic Structures Division. The hydraulic model tests were conducted by Messrs. H. R. Smith, R. Bryant, Jr., W. B. Fenwick, and S. T. Maynard under the supervision of Mr. N. R. Oswalt, Chief of the Spillways and Channels Branch. The selective withdrawal tests were conducted by Messrs. C. H. Tate, Jr., and J. A. Daub under the supervision of Dr. D. R. Smith, Chief of the Reservoir Water Quality Branch. Mr. B. F. Stanfield of the Engineering and Construction Services Division built the models. This report was prepared by Messrs. Maynard and Tate.

During the course of the model investigation, Messrs. Tom Munsey and Earl Eiker of the Office, Chief of Engineers, Mr. Glen Drummond of the Ohio River Division, and Messrs. David Beatty and Larry Curry of ORL visited WES to observe model testing and discuss test results.

COL Allen F. Grum, USA, was the previous Director of WES. COL Dwayne G. Lee, CE, is the present Commander and Director. Dr. Robert W. Whalin is the Technical Director.



Accession For	
NTIS GRA&I	<input checked="" type="checkbox"/>
DTIC TAB	<input checked="" type="checkbox"/>
Unannounced	<input type="checkbox"/>
Justification	
By _____	
Distribution/ _____	
Availability Codes	
Dist	Avail and/or Special
A1	

CONTENTS

	<u>Page</u>
PREFACE.....	1
CONVERSION FACTORS, NON-SI TO SI (METRIC) UNITS OF MEASUREMENT.....	3
PART I: INTRODUCTION.....	5
The Prototype.....	5
Existing Problem.....	5
Purpose and Scope of Model Investigations.....	6
Scale Relations.....	6
PART II: HYDRAULIC MODEL.....	8
Description.....	8
Tests and Results.....	8
PART III: SELECTIVE WITHDRAWAL MODEL.....	20
Physical Model Description.....	20
Test Procedure.....	20
Analysis and Results.....	22
PART IV: CONCLUSIONS AND RECOMMENDATIONS.....	27
Hydraulic Study.....	27
Selective Withdrawal Study.....	28
TABLES 1-18	
PLATES 1-31	

CONVERSION FACTORS, NON-SI TO SI (METRIC)
UNITS OF MEASUREMENT

Non-SI units of measurement used in this report can be converted to SI (metric) units as follows:

<u>Multiply</u>	<u>By</u>	<u>To Obtain</u>
cubic feet	0.02831685	cubic metres
Fahrenheit degrees	5/9	Celsius degrees or Kelvins*
feet	0.3048	metres
feet of water (39.2° F)	2,988.98	pascals
grams per cubic centimetre	1,000.000	kilograms per cubic metre
inches	2.54	centimetres
miles (US statute)	1.609347	kilometres
square feet	0.09290304	square metres
tons (2,000 pounds, mass)	907.1847	kilograms

* To obtain Celsius (C) temperature readings from Fahrenheit (F) readings, use the following formula: $C = (5/9)(F - 32)$. To obtain Kelvin (K) readings, use: $K = (5/9)(F - 32) + 273.15$.

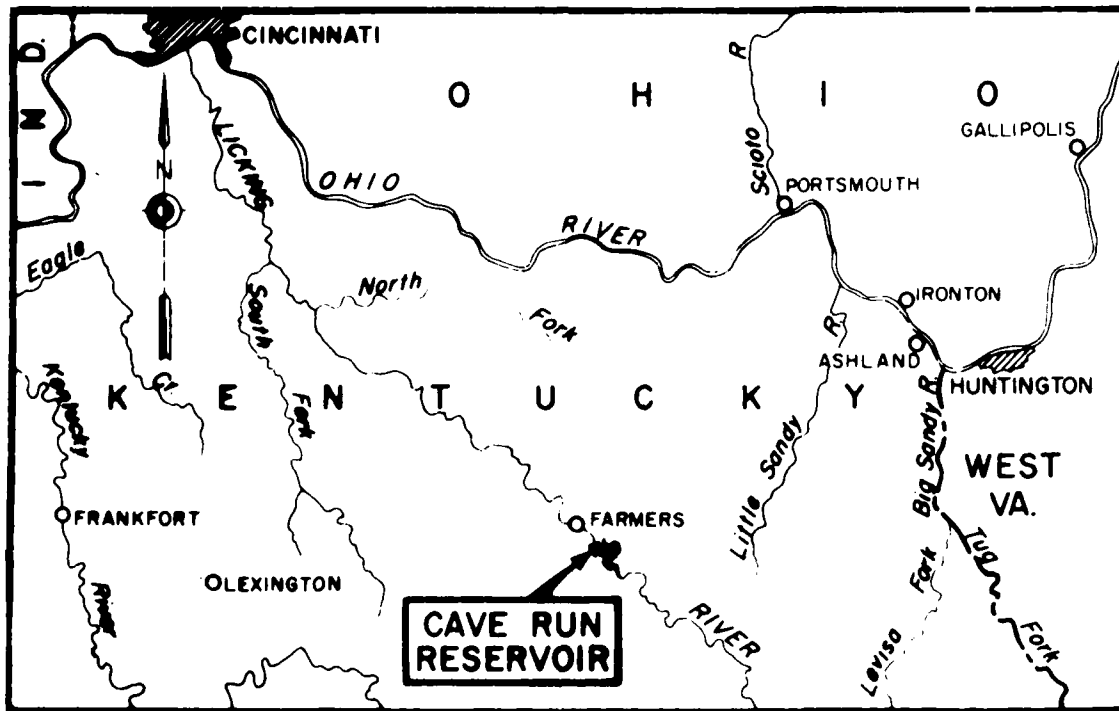

VICINITY MAP



Figure 1. Vicinity map

SELECTIVE WITHDRAWAL RISER FOR CAVE RUN LAKE

PART I: INTRODUCTION

The Prototype

1. The Cave Run Reservoir is an existing project located in east-central Kentucky, approximately 84 miles* southeast of Cincinnati, Ohio, and about 118 miles east of Louisville, Kentucky. The damsite is on the Licking River approximately 173 miles above its confluence with the Ohio River (Figure 1). Project purposes include flood control, water quality, and recreation. The reservoir will operate as a unit of the reservoir plan for the Ohio River Basin to effect reduction in flood stages at all points downstream from the reservoir. Details of the existing project are shown in Plates 1 and 2.

Existing Problem

2. Water quality problems are occurring downstream of the Cave Run project during the summer months and the fall drawdown. During this time, flows in excess of the existing selective withdrawal capacity must be released through the floodgates. These low-level releases withdraw water primarily from the hypolimnion (lower portion) of the lake. During summer and fall months, the hypolimnion of Cave Run is characterized by low levels of dissolved oxygen (DO) and high levels of dissolved iron (DFe) and dissolved manganese (DMn). Downstream water quality during releases from the hypolimnion is also characterized by low DO and high levels of DFe and DMn. These water quality problems adversely affect the downstream fisheries and the Morehead water treatment plant.

3. A selective withdrawal riser was proposed by the US Army Engineer District, Louisville (ORL), to increase the selective withdrawal capacity and minimize releases from the hypolimnion. Details of the proposed riser are shown in Plate 3. The operating plan for the proposed riser includes closing the bulkhead gates on the right side (looking downstream) of the intake

* A table of factors for converting non-SI units of measurement to SI (metric) is presented on page 3.

structure. Discharges up to the riser capacity will be passed by the right service gate. Flows in excess of the capacity will be handled by combined flow through the riser and the left (opposite) service gate.

Purpose and Scope of Model Investigations

4. The model study was conducted to evaluate the hydraulic and selective withdrawal characteristics of the proposed selective withdrawal riser and to develop modifications, if needed, to assure satisfactory performance. A 1:18-scale model was used to investigate the hydraulic adequacy of the proposed add-on riser. Operational characteristics of the structure were studied with this model, and possible modifications to the structure for improved performance were tested. Selective withdrawal studies were conducted with a 1:41.1-scale model. This was the scale ratio of an existing model intake structure, which was used for this study. Various density profiles were used to study the withdrawal patterns of the proposed riser for different operating regimes. Specific attention was focused on the withdrawal characteristics of the top port nearest the dam. The results of the physical model were incorporated into a numerical code to compute the withdrawal profile and outflow qualities for selected conditions.

Scale Relations

5. The accepted equations of hydraulic similitude, based on Froudian relations, were used to express mathematical relations between the dimensions and hydraulic quantities of the models and prototype. General relations for transference of model to prototype equivalents are as follows:

<u>Dimensions</u>	<u>Ratio</u>	<u>Hydraulic Model</u>	<u>Selective Withdrawal Model</u>
Length	$L_r = L$	1:18	1:41.1
Time	$T_r = L_r^{1/2}$	1:4.24	1:6.41
Velocity	$V_r = L_r^{1/2}$	1:4.24	1:6.41
Discharge	$Q_r = L_r^{5/2}$	1:1,375	1:10,829
Pressure	$P_r = L_r$	1:18	1:41.1

6. The water density gradient placed in the selective withdrawal model

forebay reproduced that experienced in the prototype lake. Model measurements of discharge, water-surface elevations, and pressures can be transferred quantitatively to prototype equivalents by means of the preceding scale relations.

7. A valid study of flow conditions in the outlet works required an accurate simulation of the prototype hydraulic grade line in the model. If water is the fluid in the prototype, it is not possible to satisfy simultaneously the similitude requirements of both the Reynolds and Froude criteria when water is used in the model. Since hydraulic similitude between the model and prototype was based on Froudian relations, the Reynolds number of the design flow (7,000 cfs) in the model (7.4×10^5) was lower than that of the prototype (5.7×10^7). This resulted in a larger resistance coefficient in the model ($f = 0.0081$). The excess losses in the model conduit were compensated for by constructing only a 20.5-ft length of model conduit (369 ft in the prototype) based on the relative loss of energy in the model and prototype conduits rather than the scaled length of 34.3 ft (617.0 ft in the prototype) based on geometry only.

PART II: HYDRAULIC MODEL

Description

8. The hydraulic model of the Cave Run project, constructed to a scale ratio of 1:18, included 200 ft of approach width, the intake structure (Figure 2), conduit, stilling basin, and exit channel (Figure 3). The intake structure included trashracks, bulkhead gates, service gates, and the existing 24-in. bypass for selective withdrawal releases. The proposed riser included trashracks and gates.

9. Water used in the model was supplied by pumps, and discharge was measured by calibrated venturi meters. Water-surface elevations were measured with staff gages, and pressures were measured with piezometers installed throughout the modified portion of the intake structure.

Tests and Results

10. Results for the 1:18-scale model involved determination of discharge characteristics, pressures, and flow conditions throughout the structure. Initial testing was conducted with a grate on the top of the proposed riser at el 740.0.* Vortices entered the top of the riser for many of the anticipated operating conditions. A solid roof was added to the top of the riser with an air vent extending to above the maximum pool elevation. All test results presented herein are for conditions with the solid roof design. In the original design of the proposed riser (Plate 3), the steel panels with exposed ribs were located outside the box beams, resulting in the box beams being exposed as shown in Figure 4a. The model was incorrectly constructed with steel panels added on the inside of the box beams as shown in Figure 4b. The design used in the model provided a smoother passageway and did not have the sharp break in alignment at the corners of the exposed box beams shown in Figure 4a. These sharp corners could trigger low pressure zones and increase losses through the passageway. At the conclusion of the study, the original design of the proposed riser (Figure 4a) was placed in the model and tested. Since

* All elevations (el) and stages cited herein are in feet referred to the National Geodetic Vertical Datum (NGVD).

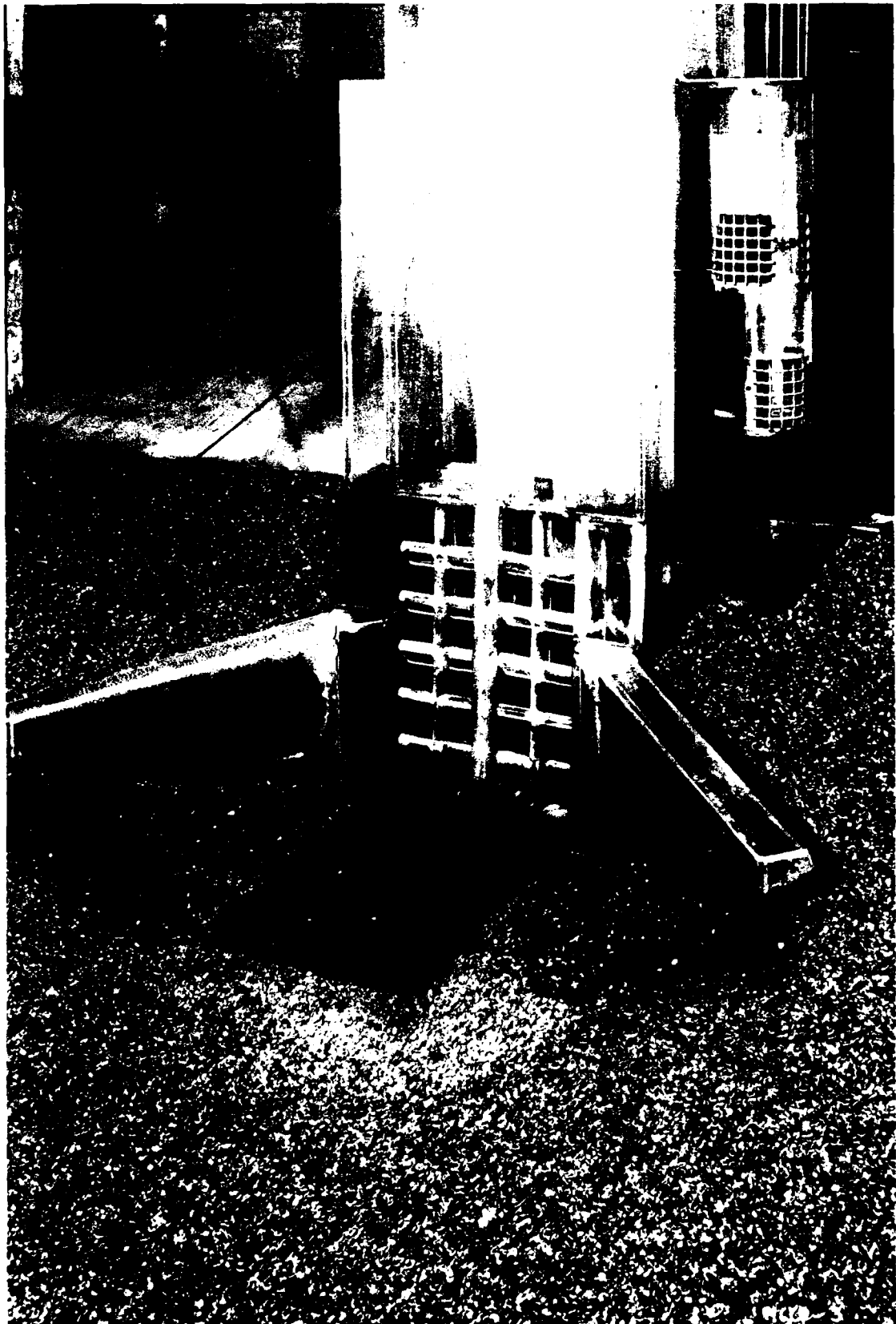

Figure 2. Intake structure with proposed selective withdrawal riser, 1:18-scale hydraulic model

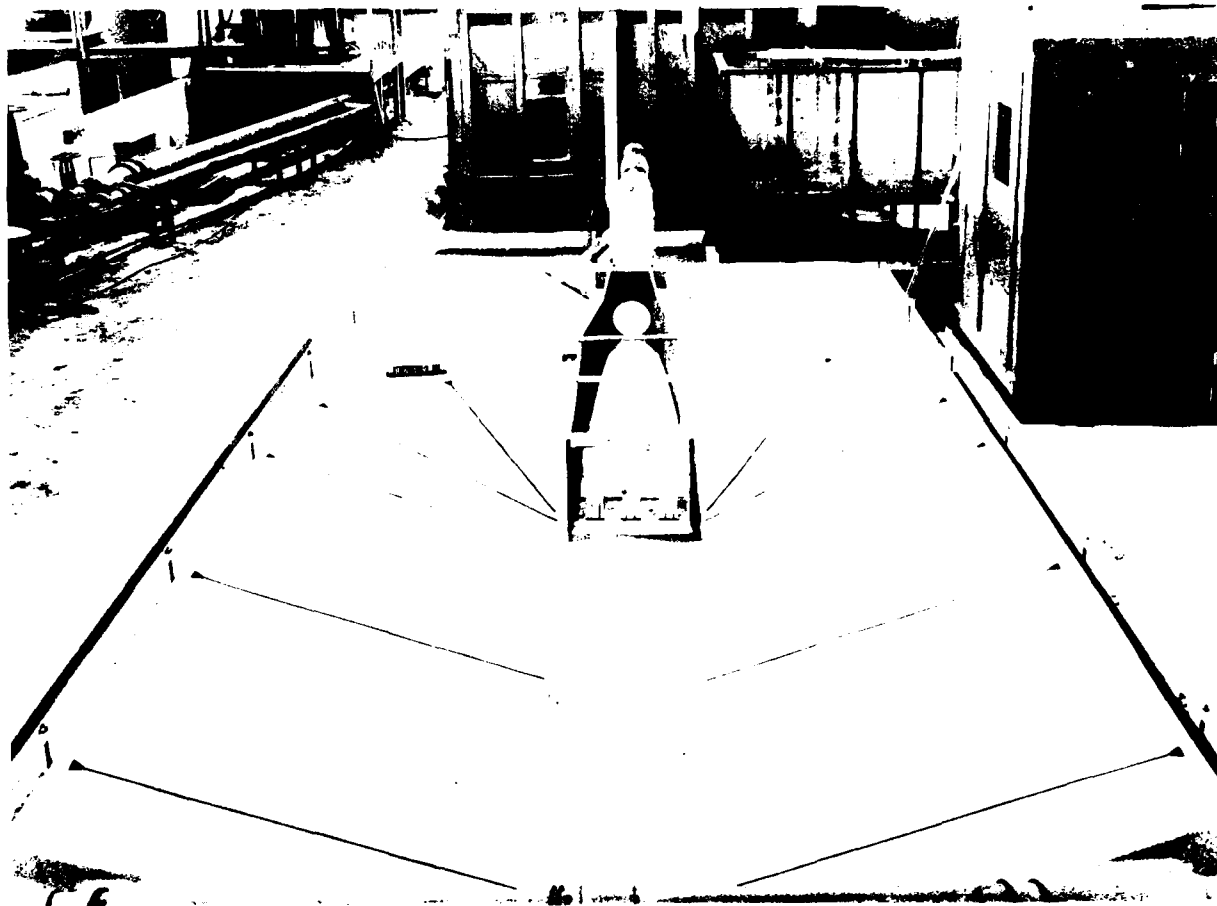
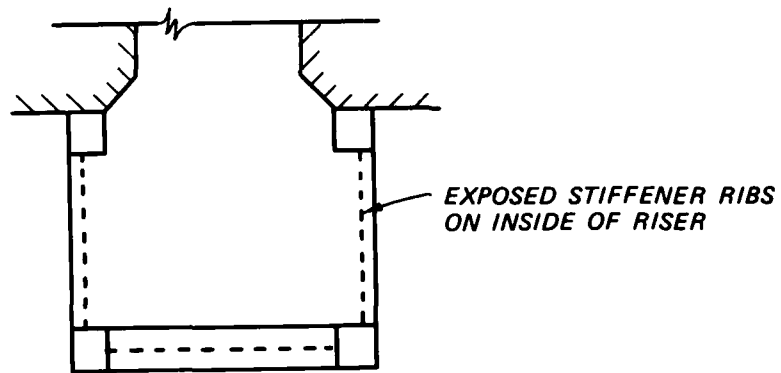

Figure 3. Conduit, stilling basin, and exit channel,
1:18-scale hydraulic model

no low pressures were found downstream of the exposed corner of the box beam and discharge rating curves were not affected by the change in geometry, either plan is acceptable. The plan shown in Figure 4b is recommended for the prototype because of the smoother passageway provided through the system.

11. Discharge characteristics of the proposed riser for the three upper, the two lower, and all five gates open are shown in Plates 4, 5, and 6, respectively. Limits for free weir flow are shown in Plate 7 for both the upper and lower intakes open.

12. Maintaining discharge control at a desired location is important in outlet works structures to prevent the potential for unstable flow due to flow control shifting from one point to another. Three modes of operation and locations of discharge control in the modified structure are depicted in Figure 5. In Figure 5a, the service gate opening is large and discharge rate



a. Plan view of original design riser

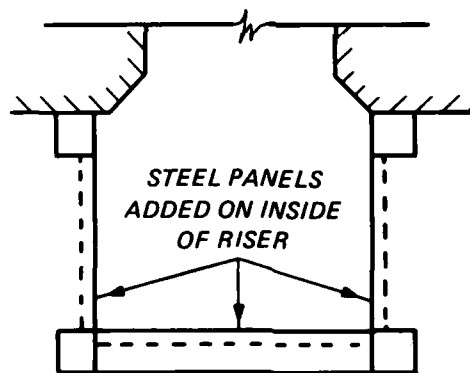

b. Plan view of design used in model tests

Figure 4. Selective withdrawal riser

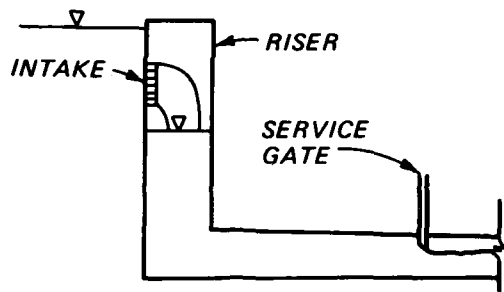

a. DISCHARGE CONTROL AT INTAKE (FREE ORIFICE FLOW-UNDESIRABLE MODE OF OPERATION)

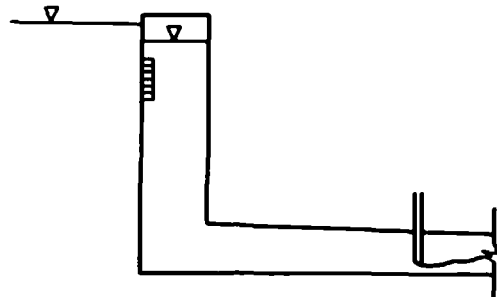

b. DISCHARGE CONTROL AT SERVICE GATE (SUBMERGED ORIFICE FLOW-DESIRED MODE OF OPERATION)

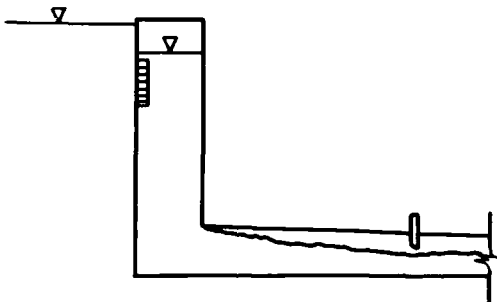

c. DISCHARGE CONTROL IN PASSAGEWAY (SUBMERGED ORIFICE FLOW-UNDESIRABLE MODE OF OPERATION)

Figure 5. Locations of discharge control

depends only on pool elevation and port size and not on the service gate opening. This mode of operation is undesirable because unstable flow and structural vibration may be induced. In Figure 5b, the discharge control is at the service gate and the discharge rate depends upon pool elevation and service gate opening. This mode of operation provides submerged orifice flow through the intake and is the objective in selective withdrawal and hydraulic designs of reservoir outlet works. A third possible mode of operation and flow control location are shown in Figure 5c in which the passageway with constrictions and bends might exert control on the discharge with an excessive service

gate opening. A region of flow transition normally occurs between these definite locations of flow control, and shifting of flow control within the transition region is a potential problem. Tests were conducted to determine the minimum pool elevation at which submerged orifice flow can exist. Initially the criterion for defining submerged orifice flow was assumed to be a water-surface elevation within the riser at or above the top of the three upper intakes or the two lower intakes. Results are shown in Plates 8 and 9 for upper and lower intakes, respectively. With the two lower intakes open, the water surface inside the riser became too rough to obtain accurate readings for right service gate openings larger than 4 ft. These results are the assumed minimum pool elevation for submerged orifice flow.

13. With the minimum upper pool elevations required for submerged orifice flow conditions shown in Plates 8 and 9, vortices and turbulence inside the proposed riser caused air to be drawn into the flow and through the outlet works. A second series of tests was conducted to determine the minimum pool at which air is not drawn through the riser. Piezometers in the passageway between the riser and the flood-control outlet works were monitored for air at various discharges and gate openings. Results are shown in Plates 10, 11, and 12 for the upper intakes, lower intakes, and all five intakes, respectively. These tests are considered important because turbulence within the riser that is sufficient to draw air through the structure may impart large periodic loadings that would be undesirable from a structural design standpoint.

14. A third series of tests on submerged orifice flow was conducted because an oscillation of pool outside the riser was observed at pool elevations slightly above the assumed limits for submerged orifice flow shown in Plates 8 and 9. The cause of this oscillation, which is some type of feedback from flow through the riser, was suspected to be either (a) a flow control shift or (b) an interaction of the jets entering the riser similar to that observed in some shaft spillway model tests. A splitter plate was installed in the model riser to determine if the oscillation was caused by interaction of the jets entering the riser. Although the size of the plate was varied, no change in the pool oscillation was observed in the model, indicating that the periodic flow control shift was not due to an interaction of the jets entering the riser, but to a shift in flow control. The pool elevation at which the oscillation starts is shown in Plates 13, 14, and 15, for upper, lower, and all five intakes open, respectively. The beginning of oscillation with the

lower ports open and gate openings larger than 4 ft could not be determined.

15. Vortices form and enter the proposed riser for some of the anticipated operating conditions. Successful modeling of surface vortices requires both a large model to minimize viscous effects and reproduction of all approach geometry affecting flow distribution to the proposed riser. The 1:18-scale model satisfied the requirements for minimal viscous effects, but reproducing all pertinent approach geometry at this scale would have been too expensive. Comparative flow distribution tests were conducted in the 1:41.1-scale selective withdrawal model. This model reproduced the important approach geometry for defining flow distribution to the intakes, but viscous forces in the model prevented accurate simulation of vortices. The 1:41.1-scale model was tested with and without the headbay wall configuration used in the 1:18-scale model. The addition of the walls did not have a major impact on the flow patterns approaching the riser. Although surface vortices did not form in the 1:41.1-scale model, small surface dimples and circulation patterns indicated by dye did form in the model, both with and without the walls. Stratification of the 1:41.1-scale model resulted in a decrease in surface dimples and circulation patterns compared with the nonstratified condition.

16. Conditions for vortex formation in the original design of the proposed riser are shown in Plates 16, 17, and 18 for the upper, lower, and all five ports open, respectively. The definition of vortex stages 0 and A-E is shown in Figure 6. The area between the upstream corner of the structure and

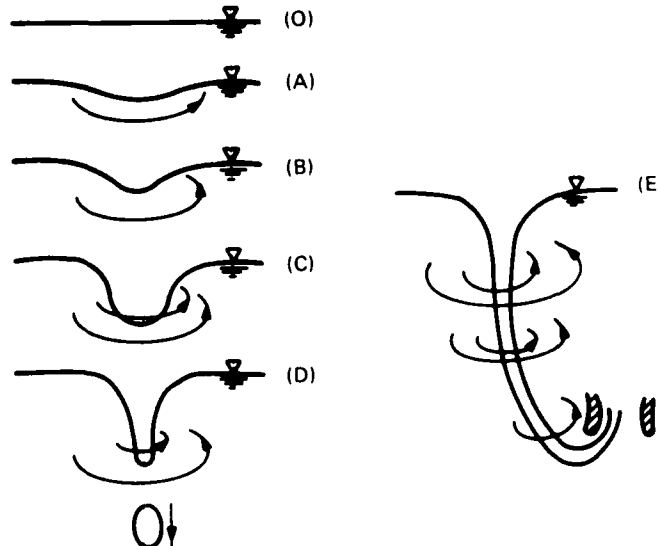
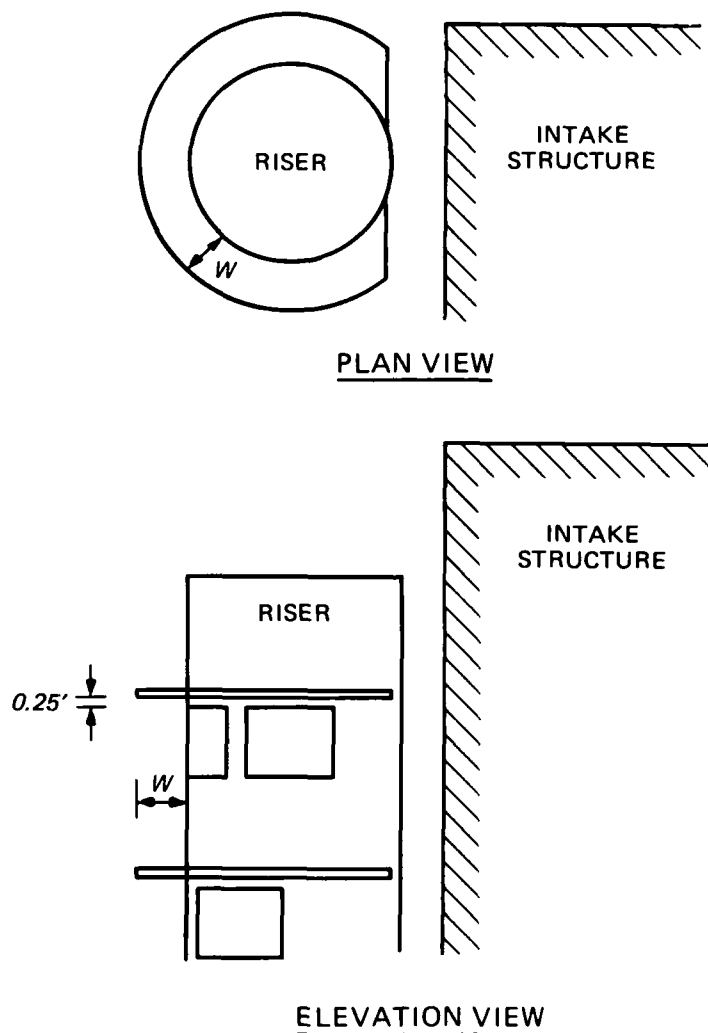

Figure 6. Stages in development of air-entraining vortices

the proposed riser is the region of most severe vortex activity. Large-scale circulation is present for almost all flow conditions.

17. Several types of vortex suppression aprons (Figure 7) were tested in the model. In the type 1 design, a 4-ft-wide solid apron was placed around the proposed riser and located approximately 0.25 ft above the top of the upper and lower ports. This design was not effective in reducing vortex activity. In the type 2 design, the width was changed to 6 ft and a pervious grating was used to allow some flow through the apron. Results are shown in Plates 19 and 20. Vortex activity was reduced, but the openings in the grate were large enough to allow circulation to pass through the grate at the lower pool elevations. In the type 3 design, the apron width was maintained at 6 ft



W = APRON WIDTH

Figure 7. Vortex suppression aprons

and the grate openings were decreased to prevent circulation from passing through the grate. Results are shown in Plates 21 and 22. Vortex activity was reduced to stage B or less for the anticipated operating conditions. In the type 4 design, the width was increased to 8 ft using the same grating material as in the type 3 design. Results in Plate 23 show less severe vortices for the 2- and 4-ft service gate openings when compared to the type 3 design. The 8-ft apron was placed on only the lower intakes since the 6-ft, type 3 apron was effective for the upper intakes. Vortex activity with all five gates open and the type 3 vortex apron on the upper ports and the type 4 apron on the lower ports is shown in Plate 24. Vortex activity was reduced to stage A or less for the anticipated operating conditions. Large-scale circulation was still present at the upstream corner with the type 4 design apron.

18. Before the vortex suppression devices were tested, ORL requested information concerning the problems associated with vortices entering the proposed riser if vortex suppression devices are not installed. Diminished capacity, safety hazards, and possible vibration due to the air present in the flow are the three major concerns. The change in capacity is small based on comparisons of discharge with and without vortices in the subject study. Floating booms placed around the intake structure are effective in eliminating the safety hazard. The remaining concern, vibration, does not occur at all structures, and it is not known whether it is a rare or common occurrence when air-entraining vortices are present.

19. Pressures in the modified intake structure were measured at the locations shown in Plate 25. Pressures for riser flow only and for combined riser flow and flow through the opposite service gate are shown in Tables 1-11 for a full range of operating conditions. Riser discharges up to 2,500 cfs were tested, and no low pressure zones were observed as a result of the relatively low average velocities through the riser passageway of 11 ft/sec with a discharge of 1,500 cfs and 18.5 ft/sec with a discharge of 2,500 cfs.

20. Discharge characteristics of the left service gate used in combined flow operation with the proposed riser are shown in Plate 26. As discussed in paragraph 3, the right side of the structure will not be used to pass flood flows under normal circumstances. However, circumstances might arise requiring opening of the bulkhead gates and right service gate to pass flood flows. Discharge characteristics for full gate openings for both gates open, left service gate open, and right service gate open are shown in Plate 27. Note

that the addition of riser flow to the right side actually makes the system less efficient. The discharge rating for partial gate openings for both service gates (riser gates closed) is shown in Plate 28. A comparison of the model rating with ORLs computed rating is given in the following tabulation:

Gate Opening, ft	Pool El 730		Pool El 755	
	Model* Q , cfs	Computed Q , cfs	Model* Q , cfs	Computed Q , cfs
3.0	2,060	2,070	2,380	2,405
4.5	3,010	3,080	3,540	3,585
6.0	3,920	4,120	4,640	4,805
7.5	4,840	5,155	5,680	6,030
9.0	5,760	6,195	6,830	**

* Expressed in prototype units.

** Not computed in ORLs rating table.

The computed rating was for the existing structure, which was not modified by the passageway between the riser and the flood-control shaft. The model rating reflects the effects of this modification and is generally 3-6 percent lower than the computed curve at the larger discharges. The conduit flowed partially full for gate openings less than 12 ft (80 percent) and full for gate openings greater than 13 ft (87 percent). Tailwater had no effect on discharge rating for any of the conditions.

21. Losses through the trashracks were determined for flood-control flow with both service gates open by taking the difference between pool elevation observed with and without the trashracks. Computed head loss using the coefficient given in ORL (1964)* was less than measured head loss in the model as shown in the following tabulation:

Gate Opening ft	Q , cfs	Pool Elevation		Head Loss	
		With Trashracks	Without Trashracks	Measured	Computed*
10	6,720	737.0	734.0	3.0	0.9
10	5,990	722.2	719.8	2.4	0.7
8	4,990	725.8	724.0	1.8	0.5
6	4,440	748.1	747.0	1.1	0.4

* Computed head loss based on coefficients given in ORL (1964).

* US Army Engineer District, Louisville. 1964 (Oct). "Cave Run Reservoir, Outlet Works," Design Memorandum No. 4, Louisville, Ky.

22. Flood-control flows through the right service gate were monitored for adverse pressure conditions in the modified flood-control passageway. Piezometers 1-6 and 13-18 (see Plate 25 for location) were monitored for low pressures. When the initial test was conducted with the riser gates open, low pressures were observed at piezometers 16, 16A, 17, and 18 (Table 12). The riser gates were then closed, and a range of discharges were monitored for low pressure zones. Test results are listed in Tables 13-15. The minimum pressure P (always at piezometer 16A) is plotted against the average velocity V_{AVG} in the flood-control passageway (Plate 29). Results show that if the right side (which has been modified by the riser opening) must be used for flood-control operation, then the discharge through the right side should be limited to a maximum of 3,500-4,000 cfs to prevent severe low pressure at the sharp break in alignment upstream of piezometer 16A. When this sharp break in alignment was rounded to a 1-ft radius, the resulting pressures, shown in Plate 29, exhibited an increase. The 1-ft radius will permit an increase in the maximum discharge that can be passed without severe negative pressures and cavitation.

23. ORL has reported cavitation problems when the 24-in. bypass is operated in conjunction with flood-control releases through the service gate. Low pressures were demonstrated in the model downstream of the 24-in. bypass for the conditions listed in Table 14. Piezometer 22 read 22.7 ft of water with the bypass closed and -1.3 ft of water with the bypass open.

24. The operation of a single service gate caused severe turbulence at the upstream end of the flood-control conduit and oscillating flow along the length of the conduit. No indication was found during the study that the single service gate flow had caused the conduit to prime and flow full.

25. The oscillations extended to and affected flow into the stilling basin. As discussed earlier, the model conduit was only 60 percent of the length of the prototype to offset the differences in roughnesses and Reynolds numbers of flow in the model and prototype. The oscillations at the end of the model conduit tended to be higher than in the prototype due to the shorter model conduit length. However, the increased friction in the model conduit caused the oscillations to dampen. The model should give satisfactory results since these two phenomena (shorter length versus increased friction) tended to offset each other. These oscillations at the downstream end of the conduit caused flow to enter the stilling basin at an angle that created eddy problems.

This additional eddying compounds the eddy action present in the Cave Run stilling basin, which is already plagued by high tailwater. Experience with other stilling basins shows that high tailwater results in flow separation and eddy action within the stilling basin. In some cases, downstream riprap protection and/or debris is transported into and violently battered against stilling basin elements, causing serious abrasion and costly repair. Stilling basin performance for equal service gate operation and riser flow only are shown in Plates 30 and 31, respectively.

PART III: SELECTIVE WITHDRAWAL MODEL

Physical Model Description

26. An existing 1:41.1-scale model of the Cave Run outlet structure was modified with the addition of the proposed add-on selective withdrawal riser (Figure 8) and the near field topography (Figure 9). Details of the proposed riser are shown in Plate 3. Watertight inserts were used as emergency gates to seal the floodgate intakes. All five gates in the selective withdrawal tower were equipped with a vertical slide gate to control which intakes would release water. Rotometers were used to measure the release flow, which was controlled with gate valves.

Test Procedure

27. Density stratification used for this study was based on observed 1976 temperature profiles for Cave Run Lake (ORL 1977).^{*} Based on these profiles, a maximum density difference of 0.0037 g/cc between the surface and bottom was placed in the model using salt and fresh water. Model stratification was adjusted to simulate the observed prototype temperature profiles. The observed density profiles exhibited a gradual change through the metalimnion rather than a two-layer regime with a sharp thermocline. Ample reservoir storage was also provided in the model flume to stabilize the density profile and to minimize water-surface fluctuations during each test.

28. For each test series, the riser gates were set and several flows were released through the model. Tests were conducted with releases through single and multiple ports located on the same level. Test discharges began at 300 cfs and continued to 1,500 cfs in increments of 300 cfs.

29. Densities were determined by measuring the conductivity and temperature of the water and relating them to calibration values for known densities. The water in the model and a sample of the outflow were analyzed to determine the average density of the outflow. The withdrawal velocity profile for each test was determined by measuring the displacement of dye streaks.

* US Army Engineer District, Louisville. 1977 (14 Jan). "Evaluation of Water Quality Conditions at Cave Run Lake," Letter Report, Louisville, Ky.

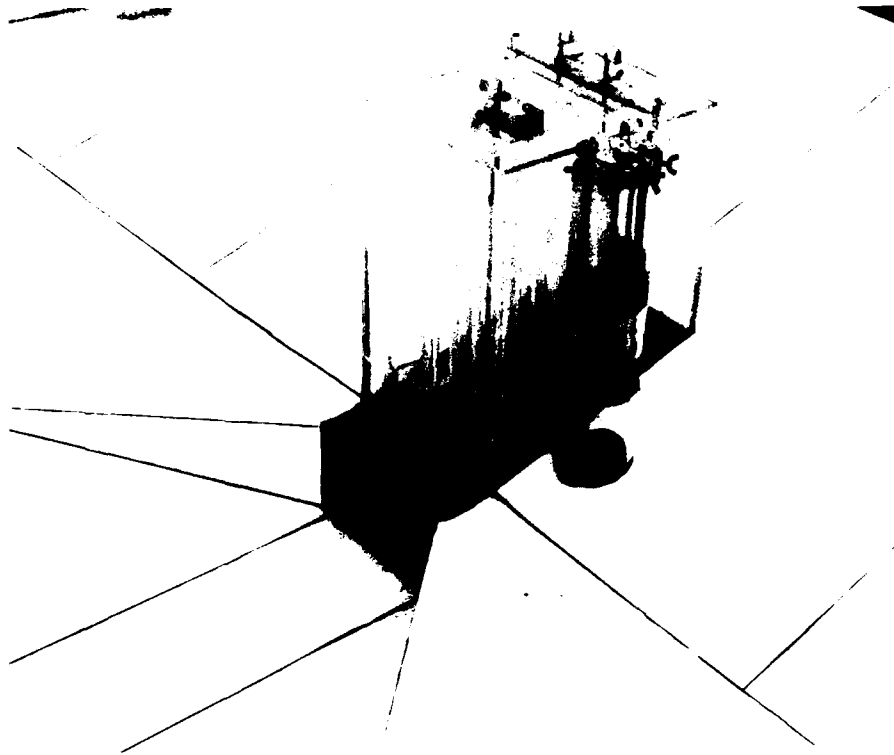

Figure 8. Intake structure and selective withdrawal riser, 1:41.1-scale selective withdrawal model

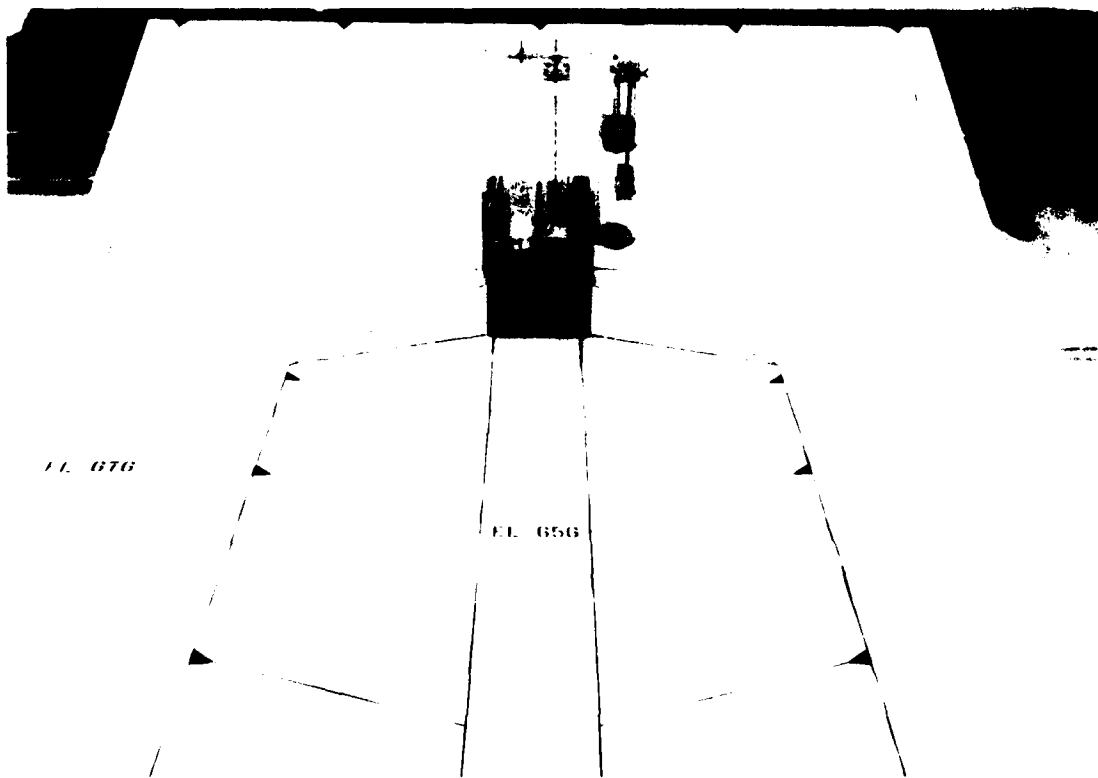

Figure 9. Near field topography, 1-41.1-scale selective withdrawal model

The movement of dye streaks across a grid was recorded with a video system. The dye streaks were traced, and the relative displacements and withdrawal limits were determined.

Analysis and Results

Limit analysis

30. Methods for predicting the limits of withdrawal have been published for density stratified flow (Bohan and Grace 1973).* For withdrawal unaffected by boundaries, these limits can be calculated by

$$Q = Z^3 \left(\frac{g \Delta \rho}{\rho Z} \right)^{1/2} \quad (1)$$

where

Q = discharge through the orifice, cfs

Z = vertical difference in the elevations of the limit in question and the center line of the orifice, ft

g = acceleration due to gravity, ft/sec²

ρ = density at the elevation of the center line of the orifice, g/cc

Δρ = density difference of fluid between the elevations of the center line of the orifice and the limit in question, g/cc

31. The majority of the velocity profiles observed for this study, however, intersected the water surface. For these cases, the total thickness of the withdrawal zone was determined using an equation developed by Smith et al.** For boundary interference, these investigators found that the thickness of the withdrawal zone is given by

$$\frac{Q}{H^3 \left(\frac{g \Delta \rho H}{\rho} \right)^{0.5}} = \frac{\frac{C_\theta}{2\pi} \left[1 + \frac{1}{\pi} \sin \left(\frac{\frac{b}{H}}{1 - \frac{b}{H}} \pi \right) + \frac{\frac{b}{H}}{1 - \frac{b}{H}} \right]}{\left(1 + \frac{\frac{b}{H}}{1 - \frac{b}{H}} \right)^3} \quad (2)$$

* J. P. Bohan and J. L. Grace, Jr. 1973 (Mar). "Selective Withdrawal from Man-Made Lakes; Hydraulic Laboratory Investigation," Technical Report H-73-4, US Army Engineer Waterways Experiment Station, Vicksburg, Miss.

** D. R. Smith et al. "Improved Description of Selective Withdrawal Through Point Sinks" (in preparation), US Army Engineer Waterways Experiment Station, Vicksburg, Miss.

where

H = total thickness of the withdrawal zone; distance from lower limit to upper limit, ft

$\Delta\rho_H$ = density difference between the boundary of interference and the elevation of the free limit, g/cc

C_θ = constant, related to the effective horizontal angle of withdrawal

b = distance between the center line of the outlet and the boundary of interference, ft

If the withdrawal is through a vertical plane, the constant C_θ is ideally equal to π . However, for this prototype, the geometry is not a vertical plane. Based upon test results, values of the constant for the add-on riser were determined to be 2π for the el 720 ports and 1.5π for the el 703 ports. Basic data are shown in the following tabulation. Additionally, the el 720 port nearest the embankment was found to have the same withdrawal characteristics as the other ports at this elevation.

<u>Q</u>	<u>H</u>	<u>$\Delta\rho_H$</u>	<u>b</u>
<u>Port El 720</u>			
300	29.2	0.00043	11.6
300	28.3	0.00066	9.5
600	35.7	0.00090	10.3
1,200	37.7	0.00116	9.5
300	33.0	0.00031	11.7
600	32.0	0.00044	9.5
<u>Port El 703</u>			
900	51.7	0.00199	25.3
900	44.4	0.00138	21.3
300	42.0	0.00063	19.3

32. After Equation 2 is solved for H when surface interference exists, the lower limit is given by

$$Z_1 = H - b \quad (3)$$

Comparison of the observed versus predicted lower limits for all tests is shown in Figure 10. The correlation coefficient is 0.993 and the standard error of estimate is 1.13 ft. Only one test had an upper withdrawal limit within the pool. For this test the observed versus predicted error was less than 1.10 ft using Equation 3.

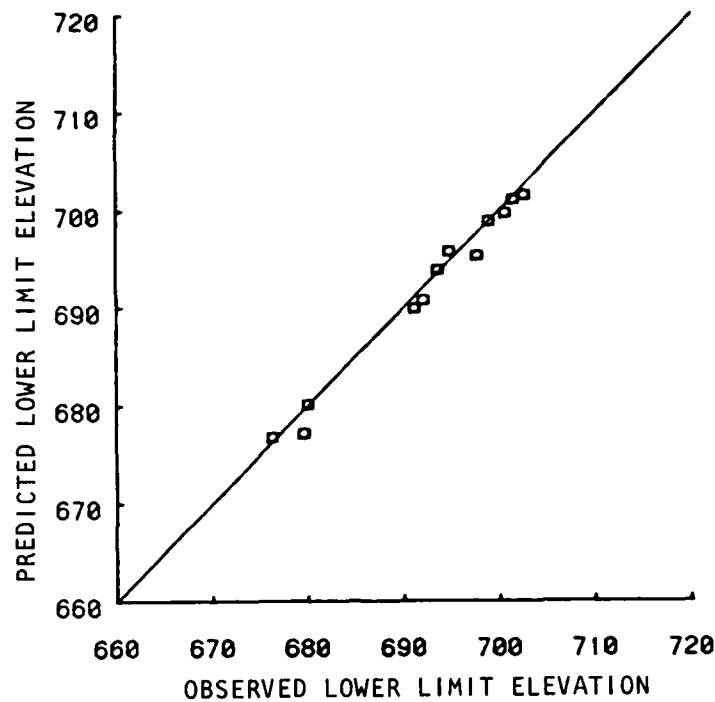

Figure 10. Observed versus predicted lower limit elevation

Maximum velocity

33. The point of maximum velocity has been determined by Bohan and Grace* to be

$$Y_L = H \left[\sin \left(\frac{1.57Z_L}{H} \right) \right]^2 \quad (4)$$

where

Y_L = distance from lower limit to location of maximum velocity, ft

Z_L = distance from lower limit to orifice center line, ft

This relationship was consistent with experimental values obtained from the Cave Run model.

Velocity profile shape

34. The shape of the velocity profile was found by Bohan and Grace* to have the form

$$\frac{V}{V_{MAX}} = \left(1 - \frac{y\Delta\rho_v}{Y\Delta\rho_{MAX}} \right)^N \quad (5)$$

* Bohan and Grace, op. cit.

where

V/V_{MAX} = ratio of local velocity to maximum velocity

y = magnitude of distance from elevation of maximum velocity to some local elevation, ft

$\Delta\rho_v$ = density difference between elevation of maximum velocity and local elevation, g/cc

Y = magnitude of distance from elevation of maximum velocity to the withdrawal limit of interest, ft

$\Delta\rho_{MAX}$ = density difference between elevation of maximum velocity and the withdrawal limit of interest, g/cc

N = 2 for orifice flow

This form places strong emphasis on the density gradient. For the Cave Run study the average exponent N was determined to be 1.39. This shape is also used to define the shape of the portion of the velocity profile above the maximum velocity. Basic data are shown in Table 16.

Numerical predictions of release values

35. The descriptions for the components of the velocity profile were combined in a numerical code to facilitate computing outflow quality based on in-lake profiles. Conditions that existed on 8 September 1976 were used as an example of a severe condition. In-lake profiles for this date (listed in Table 17) exhibited a weakened thermal stratification, minimum DO, and peak concentrations of DFe and DMn.

36. As stated previously, flows ranging from 300 to 1,500 cfs were modeled. Flows in excess of 300 cfs must be released through the floodgates in the existing structure. For the proposed structure, flows up to 1,500 cfs may be released through the selective withdrawal system. In order to keep the average velocity through the ports to a maximum of 6 ft/sec, a maximum of 300 cfs through each port was used for the numerical predictions. When the magnitude of the discharge required releases from both levels of the proposed add-on riser, 60 percent of the total flow was released through the top ports.

37. Results of the numerical predictions of outflow quality are listed in Table 18 for the various discharges and port selections defined herein. As shown in Table 18, the predicted quality of the release was significantly improved when flow was released through the tower rather than through the floodgates. The DO concentrations shown in Table 18 are the concentrations entering the structure. Actual release values would probably be increased due to

reaeration after the release flow passes the service gate. Current summer operations using the floodgates may be flushing some of the DFe and DMn from the hypolimnion. If the operation is changed to primarily surface releases, higher concentrations of DFe and DMn may exist in the hypolimnion which could result in greater water quality problems when floodgate releases are required.

PART IV: CONCLUSIONS AND RECOMMENDATIONS

Hydraulic Study

38. Model test results show that the proposed riser will operate free of hydraulic problems within certain limits of pool elevation, gate opening, and discharge. The difficulty arises in defining a reasonable scheme for operating the structure within the limits of trouble-free operation. The primary uses of the proposed riser are as follows:

- a. Maintain summer pool el 730.0 without using flood-control gates. For this objective, the upper three gates or all five gates would be used during releases.
- b. Draw down reservoir in the fall from the summer pool to the winter pool el 724.0 without using flood-control gates. For this objective, the upper three gates, the lower two gates, or all five gates could be used during releases.

Analysis of the proposed riser's primary uses (a and b above) in terms of the potential limitations will determine the effectiveness of the riser.

39. Potential limitations of the riser include submerged orifice flow, adverse pressures, turbulence within the riser (as indicated by air entrainment), pool or flow control oscillation, and vortices. Of these five factors, pool or flow control oscillation and vortices impose the most stringent requirements on limiting operation of the riser. Pressures within the proposed riser were positive for all discharges up to 2,500 cfs, indicating that adverse pressure conditions will not have as significant an effect on riser discharge as will the other four factors. Another potential limitation is the port entrance velocity which is important in trashrack and trash strut design as well as flow stability and "collection well" turbulence. Port entrance velocities of 4 to 6 ft/sec are recommended in EM 1110-2-1602, "Hydraulic Design of Reservoir Outlet Works."* Higher velocities have been used, but selective withdrawal performance can be affected. A range of port entrance velocities are used in the following tabulation to determine the maximum discharge through the proposed riser.

* US Army Corps of Engineers. 1980 (Oct). "Hydraulic Design of Reservoir Outlet Works," Engineer Manual 1110-2-1602, Office of the Chief of Engineers, Washington, DC.

Port Entrance Velocity ft/sec*	Velocity, ft/sec, Based on Net Area Through Trashracks**	Maximum Discharge, cfs, Through		
		Three Upper Gates	Two Lower Gates	All Five Gates
4	6.5	672	448	1,120
6	9.7	1,008	672	1,680
9	14.5	1,512	1,008	2,520

* Port area = 56 ft²/port.

** Net area through trashrack = 34.7 ft²/port.

These computations assume that the discharge through each port will be equal. This assumption is an approximation because losses through the different port locations will vary. However, it is adequate for the analysis of the maximum discharge through the riser and for design of trashracks or trash beams.

40. Stilling basin action is also affected by the proposed riser. Riser operation requires the operation of a single service gate, which causes stilling basin eddy action at discharges that are free of eddy action during equal operation of service gates. However, ORL has completely grouted the riprap in the exit channel and eliminated the downstream source of material that can wash back into the stilling basin during eddy action. This grouting should prevent the damage caused by riprap in the basin abrading the bottom of the basin.

41. The following recommendations are made for the proposed riser:

- a. The vortex analysis shown in Plates 16-24 and the maximum discharges based on a port entrance velocity of 9 ft/sec show that the type 3 apron (6 ft wide) on upper and lower ports will minimize vortex activity. Therefore, the type 3 apron is recommended for the prototype.
- b. Operation of the prototype above the pool oscillation curves shown in Plates 13-15 is recommended to avoid flow control shifting within the proposed riser. Operation above this curve also satisfies the limits for submerged orifice flow (Plates 8 and 9) and the limits for turbulence within the riser sufficient to cause air transport (Plates 10-12).
- c. Maximum riser discharge will also be controlled by port entrance velocities that will depend on trashrack or trash strut design.

Selective Withdrawal Study

42. The selective withdrawal characteristics of the proposed add-on riser have been defined such that the release concentrations of parameters

(treated as conservative) can be predicted given the in-lake profile. Based on the 8 September 1976 profiles, this design will result in a significant improvement in the release water quality during the summer stratification season. The amount of improvement will be dependent on the density stratification and release rates. Of specific interest in the study was investigation of the selective withdrawal characteristics of the top riser port nearest the embankment. Test results have shown the withdrawal characteristics of this port to be essentially the same as for the other ports. Thus, operations using this port will not degrade the overall performance of the proposed riser.

43. The construction and operation of this riser will change the water quality within the reservoir due to reduced low level releases. Such changes will probably include increased levels of DFe and DMn in the hypolimnion. The response of the lake to changing release operations should be investigated by ORL.

Table 1

Static Pressures in Modified Intake StructureRiser Discharge = 500 cfs;Discharge Through Opposite Service Gate = 0 cfs;Pool El = 723.8; Lower Riser Gates

<u>Piezometer Number</u>	<u>Piezometer Elevation</u>	<u>Pressure Reading*</u>	<u>Static Pressure**</u>
1	670.8	722.4	51.6
2	663.4	722.5	59.1
3	656.9	722.4	65.5
4	669.5	722.4	52.9
5	664.5	722.5	58.0
6	657.8	722.5	64.7
7	672.0	721.7	49.7
7A	668.5	721.5	53.0
8	665.4	722.0	56.6
9	658.2	722.2	64.0
10	672.6	722.0	49.4
11	665.0	722.0	57.0
12	657.8	721.9	64.1
13	671.3	722.0	50.7
13A	667.6	721.5	53.9
14	663.9	721.4	57.5
15	656.5	721.5	65.0
16	670.8	722.0	51.2
16A	667.1	721.6	54.5
17	663.4	721.5	58.1
18	656.5	721.5	65.0
19	672.8	722.5	49.7
19A	672.9	722.4	49.5
20	674.8	722.5	47.7
20A	674.9	722.1	47.2
21	675.0	722.0	47.0
22	657.3	†	†

* Pressure readings are elevations.

** Static pressures are given in feet of water.

† No reading.

Table 2

Static Pressures in Modified Intake StructureRiser Discharge = 500 cfs;Discharge Through Opposite Service Gate = 0 cfs;Pool El = 729.5; Upper Riser Gates

<u>Piezometer Number</u>	<u>Piezometer Elevation</u>	<u>Pressure Reading*</u>	<u>Static Pressure**</u>
1	670.8	729.3	58.5
2	663.4	729.5	66.1
3	656.9	729.3	72.4
4	669.5	729.0	59.5
5	664.5	729.2	64.7
6	657.8	729.3	71.5
7	672.0	728.7	56.7
7A	668.5	721.7	53.2
8	665.4	728.7	63.3
9	658.2	729.0	70.8
10	672.6	728.5	55.9
11	665.0	728.6	63.6
12	657.8	728.7	70.9
13	671.3	728.6	57.3
13A	667.6	728.6	61.0
14	663.9	728.0	64.1
15	656.5	728.0	71.5
16	670.8	728.6	57.8
16A	667.1	728.2	61.1
17	663.4	728.2	64.8
18	656.5	727.5	71.0
19	672.8	727.8	55.0
19A	672.9	724.3	51.4
20	674.8	724.4	49.6
20A	674.9	723.3	48.4
21	675.0	718.8	43.8
22	657.3	†	†

* Pressure readings are elevations.

** Static pressures are given in feet of water.

† No reading.

Table 3

Static Pressures in Modified Intake StructureRiser Discharge = 1,000 cfs;Discharge Through Opposite Service Gate = 0 cfs;Pool El = 724.5; Lower Riser Gates

<u>Piezometer Number</u>	<u>Piezometer Elevation</u>	<u>Pressure Reading*</u>	<u>Static Pressure**</u>
1	670.8	717.5	46.7
2	663.4	717.6	54.2
3	656.9	717.6	60.7
4	669.5	717.4	47.9
5	664.5	717.7	53.2
6	657.8	717.8	60.0
7	672.0	715.0	43.0
7A	668.5	710.6	42.1
8	665.4	713.5	48.1
9	658.2	716.6	58.4
10	672.6	713.3	40.7
11	665.0	715.5	50.5
12	657.8	715.7	57.9
13	671.3	715.0	43.7
13A	667.6	715.1	47.5
14	663.9	713.5	49.6
15	656.5	714.0	57.5
16	670.8	712.8	42.0
16A	667.1	712.5	45.4
17	663.4	714.5	51.1
18	656.5	714.3	57.8
19	672.8	712.7	39.9
19A	672.9	712.4	39.5
20	674.8	717.5	42.7
20A	674.9	712.6	37.7
21	675.0	707.4	32.4
22	657.3	670.0	12.7

* Pressure readings are elevations.

** Static pressures are given in feet of water.

Table 4

Static Pressures in Modified Intake StructureRiser Discharge = 1,000 cfs;Discharge Through Opposite Service Gate = 0 cfs;Pool El = 730.0; Upper Riser Gates

<u>Piezometer Number</u>	<u>Piezometer Elevation</u>	<u>Pressure Reading*</u>	<u>Static Pressure**</u>
1	670.8	726.4	55.6
2	663.4	726.6	63.2
3	656.9	726.7	69.8
4	669.5	726.0	56.5
5	664.5	726.5	62.0
6	657.8	726.7	68.9
7	672.0	724.3	52.3
7A	668.5	718.8	50.3
8	665.4	724.4	59.0
9	658.2	725.5	67.3
10	672.6	724.5	51.9
11	665.0	724.6	59.6
12	657.8	725.0	67.2
13	671.3	724.5	53.2
13A	667.6	723.6	56.0
14	663.9	722.5	58.6
15	656.6	722.4	65.9
16	670.8	725.3	54.5
16A	667.1	723.7	56.6
17	663.4	723.5	60.1
18	656.5	722.1	65.6
19	672.8	725.4	52.6
19A	672.9	721.8	48.9
20	674.8	721.6	46.8
20A	674.9	720.4	45.5
21	675.0	716.5	41.5
22	657.3	†	†

* Pressure readings are elevations.

** Static pressures are given in feet of water.

† No reading.

Table 5

Static Pressures in Modified Intake StructureRiser Discharge = 1,500 cfs;Discharge Through Opposite Service Gate = 0 cfs;Pool El = 723.5; Lower Riser Gates

<u>Piezometer Number</u>	<u>Piezometer Elevation</u>	<u>Pressure Reading*</u>	<u>Static Pressure**</u>
1	670.8	708.4	37.6
2	663.4	709.0	45.6
3	656.9	709.0	52.1
4	669.5	707.5	38.0
5	664.5	708.5	44.0
6	657.8	709.1	51.3
7	672.0	704.3	32.3
7A	668.5	701.5	33.0
8	665.4	702.5	37.1
9	658.2	706.3	48.1
10	672.6	704.7	32.1
11	665.0	704.5	39.5
12	657.8	704.3	46.5
13	671.3	705.0	33.7
13A	667.6	701.4	33.8
14	663.9	698.0	34.1
15	656.5	701.5	45.0
16	670.8	705.0	34.2
16A	667.1	701.5	34.4
17	663.4	700.5	37.1
18	656.5	700.7	44.2
19	672.8	707.6	34.8
19A	672.9	706.6	33.7
20	674.8	709.5	34.7
20A	674.9	706.9	32.0
21	675.0	697.5	22.5
22	657.3	668.5	11.2

* Pressure readings are elevations.

** Static pressures are given in feet of water.

Table 6

Static Pressures in Modified Intake StructureRiser Discharge = 1,500 cfs;Discharge Through Opposite Service Gate = 0 cfs;Pool El = 730.5; Upper Riser Gates

<u>Piezometer Number</u>	<u>Piezometer Elevation</u>	<u>Pressure Reading*</u>	<u>Static Pressure**</u>
1	670.8	721.7	50.9
2	663.4	722.2	58.8
3	656.9	722.5	65.6
4	669.5	721.4	51.9
5	664.5	722.4	57.9
6	657.8	722.5	64.7
7	672.0	717.5	45.5
7A	668.5	716.5	48.0
8	665.4	718.0	52.6
9	658.2	719.6	61.4
10	672.6	717.5	44.9
11	665.0	717.0	52.0
12	657.8	718.5	60.7
13	671.3	717.5	46.2
13A	667.6	714.5	46.9
14	663.9	713.0	49.1
15	656.5	713.5	57.0
16	670.8	718.4	47.6
16A	667.1	715.5	48.4
17	663.4	715.5	52.1
18	656.5	712.5	56.0
19	672.8	722.5	49.7
19A	672.9	720.5	47.6
20	674.8	721.3	46.5
20A	674.9	719.0	44.1
21	675.0	710.5	35.5
22	657.3	671.5	13.2

* Pressure readings are elevations.

** Static pressures are given in feet of water.

Table 7

Static Pressures in Modified Intake StructureRiser Discharge = 1,500 cfs;Discharge Through Opposite Service Gate = 2,500 cfs;Pool El = 723.9; Lower Riser Gates

<u>Piezometer Number</u>	<u>Piezometer Elevation</u>	<u>Pressure Reading*</u>	<u>Static Pressure**</u>
1	670.8	708.5	37.7
2	663.4	708.8	45.4
3	656.9	709.4	52.5
4	669.5	708.0	38.5
5	664.5	709.0	44.5
6	657.8	709.1	51.3
7	672.0	704.4	32.4
7A	668.5	703.5	35.0
8	665.4	704.5	39.1
9	658.2	707.0	48.8
10	672.6	705.5	32.9
11	665.0	704.5	39.5
12	657.8	704.6	46.8
13	671.3	705.5	34.2
13A	667.6	701.0	33.4
14	663.9	698.5	34.6
15	656.5	701.2	44.7
16	670.8	706.0	35.2
16A	667.1	702.2	35.1
17	663.4	700.7	37.3
18	656.5	701.5	45.0
19	672.8	708.5	35.7
19A	672.9	707.0	33.5
20	674.8	708.0	33.2
20A	674.9	706.5	31.6
21	675.0	699.3	24.3
22	657.3	†	†

* Pressure readings are elevations.

** Static pressures are given in feet of water.

† No reading.

Table 8

Static Pressures in Modified Intake StructureRiser Discharge = 1,500 cfs;Discharge Through Opposite Service Gate = 2,500 cfs;Pool El = 730.5; Upper Riser Gates

<u>Piezometer Number</u>	<u>Piezometer Elevation</u>	<u>Pressure Reading*</u>	<u>Static Pressure**</u>
1	670.8	722.8	52.0
2	663.4	723.2	59.8
3	656.9	723.7	66.8
4	669.5	722.5	53.0
5	664.5	723.5	59.0
6	657.8	724.0	66.2
7	672.0	720.4	48.4
7A	668.5	717.4	48.9
8	665.4	719.4	54.0
9	658.2	720.5	62.3
10	672.6	719.5	46.9
11	665.0	718.6	53.6
12	657.8	719.5	61.7
13	671.3	719.0	47.7
13A	667.6	715.0	47.4
14	663.9	714.5	50.6
15	656.5	714.0	57.5
16	670.8	719.5	48.7
16A	667.1	718.3	51.2
17	663.4	716.5	53.1
18	656.5	714.5	58.0
19	672.8	723.6	50.8
19A	672.9	718.5	45.6
20	674.8	721.0	46.2
20A	674.9	719.2	44.3
21	675.0	711.5	36.5
22	657.3	†	†

* Pressure readings are elevations.

** Static pressures are given in feet of water.

† No reading.

Table 9

Static Pressures in Modified Intake StructureRiser Discharge = 2,000 cfs;Discharge Through Opposite Service Gate = 0 cfs;Pool El = 730.4; Lower Riser Gates

<u>Piezometer Number</u>	<u>Piezometer Elevation</u>	<u>Pressure Reading*</u>	<u>Static Pressure**</u>
1	670.8	703.6	32.8
2	663.4	703.5	40.1
3	656.9	702.5	45.6
4	669.5	704.5	35.0
5	664.5	704.7	40.2
6	657.8	704.7	46.9
7	672.0	696.5	24.5
7A	668.5	693.2	24.7
8	665.4	698.0	32.6
9	658.2	699.0	41.7
10	672.6	698.3	25.7
11	665.0	696.0	31.0
12	657.8	696.5	38.7
13	671.3	697.5	26.2
13A	667.6	690.0	22.4
14	663.9	686.5	22.6
15	656.5	690.0	33.5
16	670.8	697.5	26.7
16A	667.1	689.5	22.4
17	663.4	690.5	27.1
18	656.6	691.5	35.0
19	672.8	699.0	26.2
19A	672.9	700.0	27.1
20	674.8	706.0	31.2
20A	674.9	705.0	30.1
21	675.0	696.5	21.5
22	657.3	†	†

* Pressure readings are elevations.

** Static pressures are given in feet of water.

† No reading.

Table 10

Static Pressures in Modified Intake StructureRiser Discharge = 2,000 cfs;Discharge Through Opposite Service Gate = 0 cfs;Pool El = 736.0; Lower Riser Gates

<u>Piezometer Number</u>	<u>Piezometer Elevation</u>	<u>Pressure Reading*</u>	<u>Static Pressure**</u>
1	670.8	711.5	40.7
2	663.4	712.6	49.2
3	656.9	713.0	56.1
4	669.5	710.5	41.0
5	664.5	712.5	48.0
6	657.8	712.8	55.0
7	672.0	704.5	32.5
7A	668.5	699.5	31.0
8	665.4	706.5	41.1
9	658.2	708.5	50.3
10	672.6	705.5	32.9
11	665.0	705.0	40.0
12	657.8	705.3	47.5
13	671.3	705.5	34.2
13A	667.6	698.0	30.4
14	663.9	695.3	31.4
15	656.5	699.3	42.8
16	670.8	705.5	34.7
16A	667.1	699.5	32.4
17	663.4	698.5	35.1
18	656.5	700.0	43.5
19	672.8	707.5	34.7
19A	672.9	707.3	34.4
20	674.8	712.7	37.9
20A	674.9	707.0	32.1
21	675.0	704.5	29.5
22	657.3	671.5	14.2

* Pressure readings are elevations.

** Static pressures are given in feet of water.

Table 11

Static Pressures in Modified Intake StructureRiser Discharge = 2,500 cfs;Discharge Through Opposite Service Gate = 0 cfs;Pool El = 740.8; Upper Riser Gates

<u>Piezometer Number</u>	<u>Piezometer Elevation</u>	<u>Pressure Reading*</u>	<u>Static Pressure**</u>
1	670.8	719.5	48.7
2	663.4	720.5	57.1
3	656.9	722.0	65.1
4	669.5	718.0	48.5
5	664.5	721.0	56.5
6	657.8	721.5	63.7
7	672.0	706.0	34.0
7A	668.5	700.0	31.5
8	665.4	709.0	43.6
9	658.2	714.0	55.8
10	672.6	708.0	35.4
11	665.0	708.0	43.0
12	657.8	712.0	54.2
13	671.3	709.0	37.7
13A	667.6	700.0	32.4
14	663.9	697.0	33.1
15	656.5	697.0	40.5
16	670.8	711.0	40.2
16A	667.1	700.0	32.9
17	663.4	703.0	39.6
18	656.5	701.0	44.5
19	672.8	711.0	38.2
19A	672.9	712.0	39.1
20	674.8	720.0	45.2
20A	674.9	712.0	37.1
21	675.0	710.0	35.0
22	657.3	674.0	16.7

* Pressure readings are elevations.

** Static pressures are given in feet of water.

Table 12

Static Pressures in Modified Intake Structure
All Riser Gates Open; Left Service Gate Closed;
Right Service Gate Open Full; Pool El = 730.0;
Discharge = 4,890 cfs

<u>Piezometer Number</u>	<u>Piezometer Elevation</u>	<u>Pressure Reading*</u>	<u>Static Pressure**</u>
1	670.8	719.8	49.0
2	663.4	721.5	58.1
3	656.9	721.0	64.1
4	669.5	719.5	50.0
5	664.5	721.5	57.0
6	657.8	720.8	53.0
13	671.3	699.3	31.7
13A	667.6	692.5	24.9
14	663.9	679.5	15.6
15	656.5	696.5	40.0
16	670.8	668.5	-2.0
16A	667.1	664.5	-2.6
17	663.4	662.5	-0.9
18	656.5	655.7	-0.8

* Pressure readings are elevations.

** Static pressures are given in feet of water.

Table 13

Static Pressures in Modified Intake Structure
Riser Closed; Left Service Gate Closed;
Right Service Gate Open Full; Pool El = 730.0;
Discharge = 5,110 cfs

<u>Piezometer Number</u>	<u>Piezometer Elevation</u>	<u>Pressure Reading*</u>	<u>Static Pressure**</u>
1	670.8	691.8	21.0
2	663.4	694.0	30.6
3	656.9	692.5	35.6
4	669.5	689.5	20.0
5	664.5	690.1	25.6
6	657.8	690.5	32.7
13	671.3	683.0	11.7
13A	667.6	686.5	18.9
14	663.9	711.5	47.6
15	656.5	719.5	63.0
16	670.8	660.5	-10.3
16A	667.1	636.0	-31.1
17	663.4	645.0	-18.4
18	656.5	636.0	-20.5

* Pressure readings are elevations.

** Static pressures are given in feet of water.

Table 14

Static Pressures in Modified Intake StructureRiser Closed; Both Service Gates Open 11.8 ftPool El = 726.3; Discharge = 7,270 cfs

<u>Piezometer Number</u>	<u>Piezometer Elevation</u>	<u>Pressure Reading*</u>	<u>Static Pressure**</u>
1	670.8	706.5	35.7
2	663.4	707.5	44.1
3	656.9	706.5	49.6
4	669.5	705.4	35.9
5	664.5	705.5	41.0
6	657.8	705.5	47.7
13	671.3	701.8	30.5
13A	667.6	703.3	35.7
14	663.9	713.5	49.6
15	656.5	719.6	63.1
16	670.8	692.0	21.2
16A	667.1	680.0	12.9
17	663.4	682.0	18.6
18	656.5	677.5	21.0
22	657.3	680.0	22.7
22†	657.3	656.0	-1.3

* Pressure readings are elevations.

** Static pressures are given in feet of water.

† 24-in. bypass open.

Table 15

Static Pressures in Modified Intake StructureRiser Closed; Both Service Gates Open FullPool El = 719.3; Discharge = 8,175 cfs

<u>Piezometer Number</u>	<u>Piezometer Elevation</u>	<u>Pressure Reading*</u>	<u>Static Pressure**</u>
1	670.8	695.5	24.7
2	663.4	696.8	33.4
3	656.9	696.0	39.1
4	669.5	694.5	25.0
5	664.5	694.6	30.1
6	657.8	694.6	36.8
13	671.3	690.0	18.7
13A	667.6	692.5	24.9
14	663.9	706.5	42.6
15	656.5	714.0	57.5
16	670.8	677.3	6.5
16A	667.1	664.5	-2.6
17	663.4	668.5	5.1
18	656.5	663.5	7.0

* Pressure readings are elevations.

** Static pressures are given in feet of water.

Table 16

Basic Data for Determining the Shape of the
Velocity Profile

$\frac{V}{V_{MAX}}$	$\frac{y}{Y}$	$\frac{\Delta\rho_v}{\Delta\rho_{MAX}}$	$1 - \frac{y\Delta\rho_v}{Y\Delta\rho_{MAX}}$
0.96	0.15	0.13	0.98
0.79	0.33	0.31	0.90
0.59	0.52	0.59	0.69
0.18	0.89	0.94	0.17
0.999	0.05	0.01	1.00
0.92	0.26	0.06	0.98
0.78	0.47	0.19	0.91
0.56	0.69	0.35	0.76
0.24	0.90	0.72	0.35
0.91	0.22	0.10	0.98
0.73	0.47	0.26	0.88
0.60	0.70	0.49	0.66
0.97	0.20	0.05	0.99
0.85	0.39	0.13	0.95
0.69	0.58	0.30	0.83
0.44	0.76	0.55	0.58
0.16	0.96	0.91	0.12
0.96	0.10	0	1.00
0.895	0.15	0.05	0.99
0.86	0.41	0.09	0.96
0.78	0.56	0.18	0.90
0.63	0.71	0.30	0.79
0.45	0.87	0.57	0.51

Table 17
8 September 1976 Profiles

<u>Elevation</u>	<u>Temperature °F</u>	<u>Dissolved Oxygen mg/l</u>	<u>Dissolved Iron µg/l</u>	<u>Dissolved Manganese µg/l</u>
730	76.0	8.0	100	20
720	75.0	7.5	100	20
710	73.0	5.0	100	20
700	63.0	3.6	100	600
690	56.0	0	600	1,500
680	55.0	0	2,000	2,300
670	54.0	0	4,000	3,000
660	54.0	0	4,000	3,000

Table 18
Computed Release Quality
Based on 8 September 1976 Profiles
and Water Surface at El 730.0

<u>Discharge cfs</u>	<u>Release Elevations</u>	<u>Temperature °F</u>	<u>Dissolved Oxygen mg/l</u>	<u>Dissolved Iron µg/l</u>	<u>Dissolved Manganese µg/l</u>
300	720	74.29	6.73	100	34
	720 & 703	71.16	5.65	114	198
	703	66.55	3.92	155	454
	Floodgate	55.14	0.01	1,970	2,181
600	720	73.81	6.55	100	56
	720 & 703	71.10	5.57	120	204
	703	66.85	4.01	178	461
	Floodgate	55.71	0.17	1,520	1,936
900	720	73.41	6.42	101	76
	720 & 703	71.00	5.53	124	213
	Floodgate	56.25	0.39	1,324	1,798
1,200	720 & 703	70.91	5.45	128	220
	Floodgate	56.90	0.68	1,158	1,662
1,500	720 & 703	70.79	5.46	131	230
	Floodgate	57.45	0.91	1,050	1,563

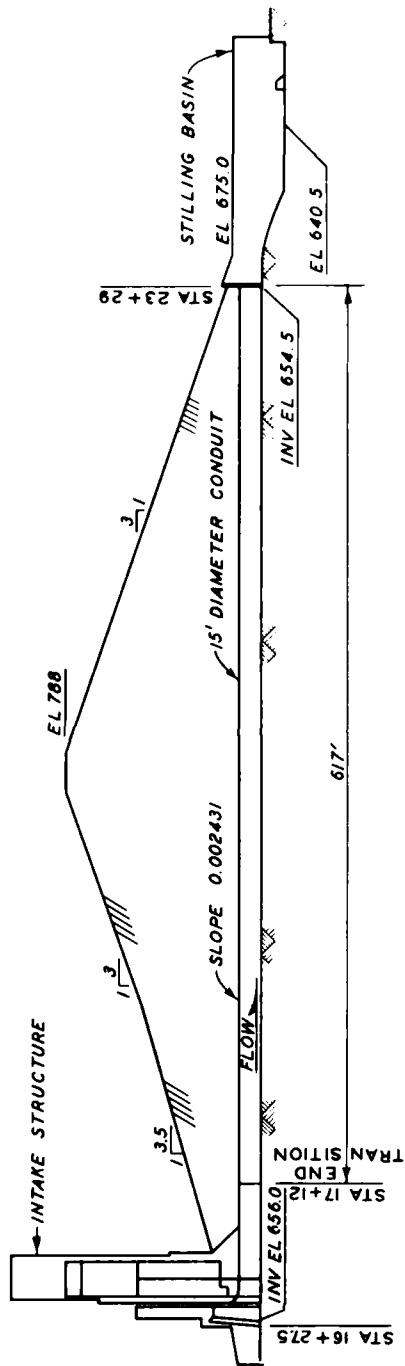

PROFILE

GENERAL LAYOUT

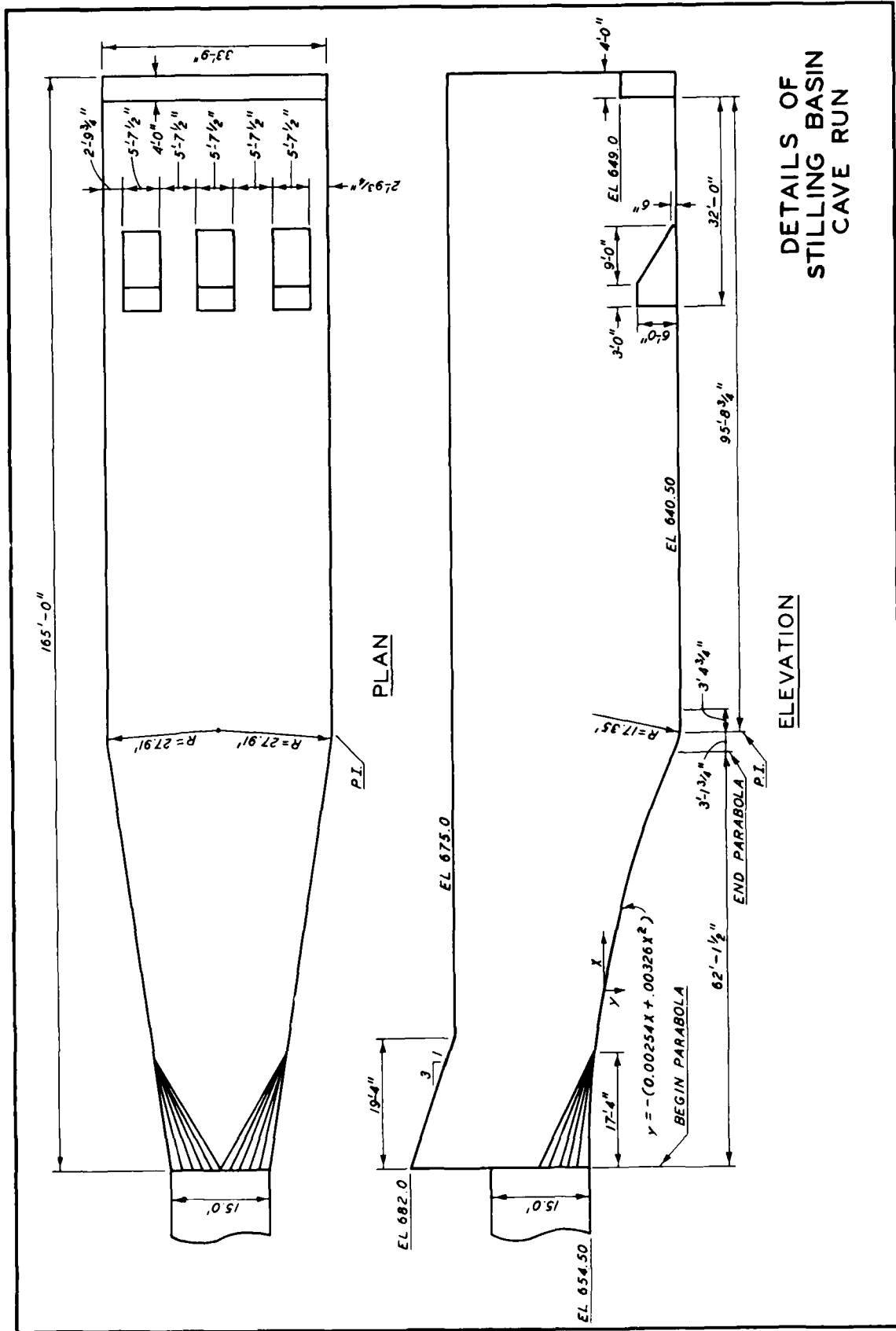

DETAILS OF
STILLING BASIN
CAVE RUN

PLATE 2

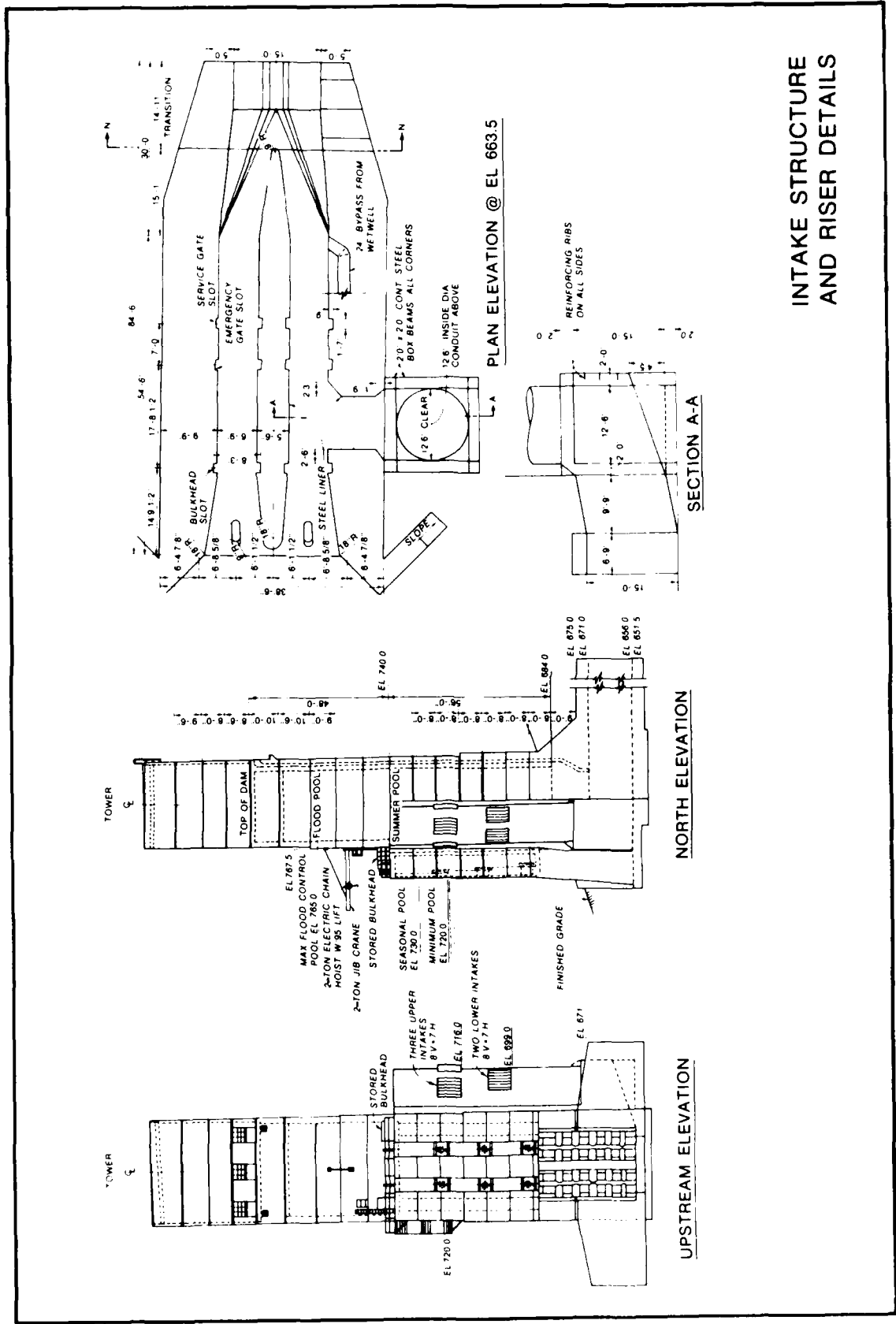

INTAKE STRUCTURE AND RISER DETAILS

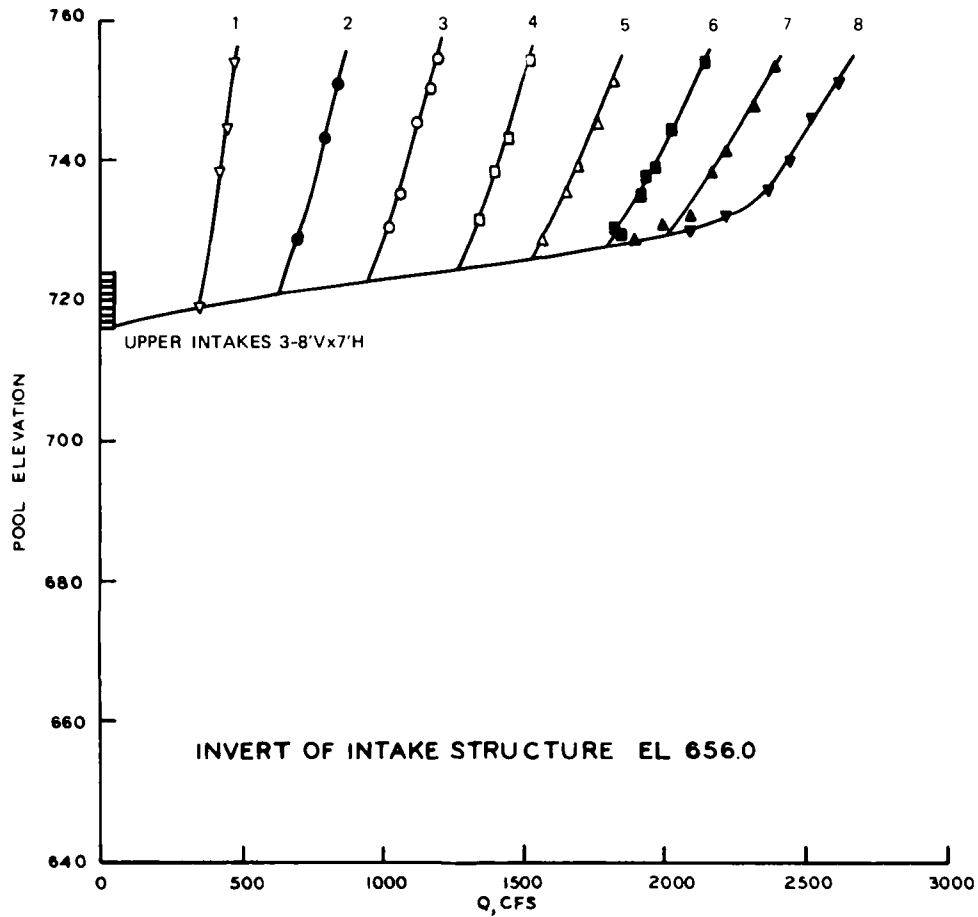

NOTE: NUMBER ON CURVE REFERS TO
SERVICE GATE OPENING IN FEET

DISCHARGE RATING CURVES
FOR SELECTIVE WITHDRAWAL
RISER

UPPER INTAKES OPEN

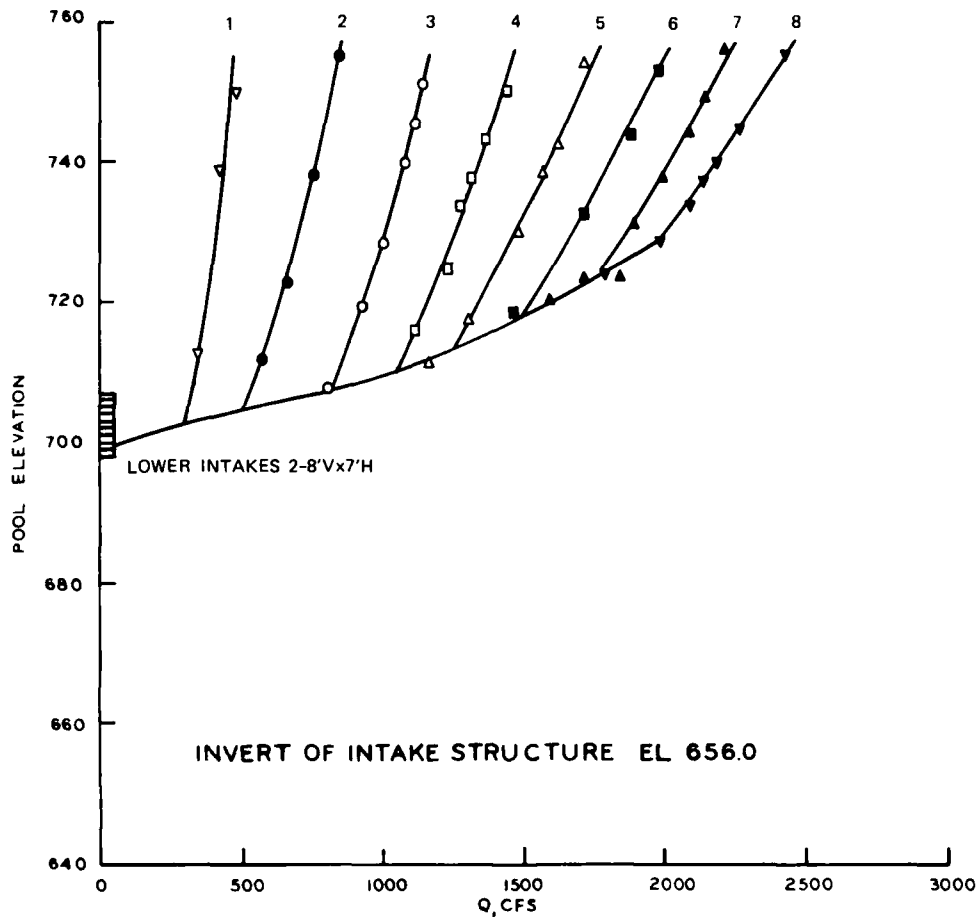

NOTE: NUMBER ON CURVE REFERS TO
SERVICE GATE OPENING IN FEET.

DISCHARGE RATING CURVES
FOR SELECTIVE WITHDRAWAL
RISER
LOWER INTAKES OPEN

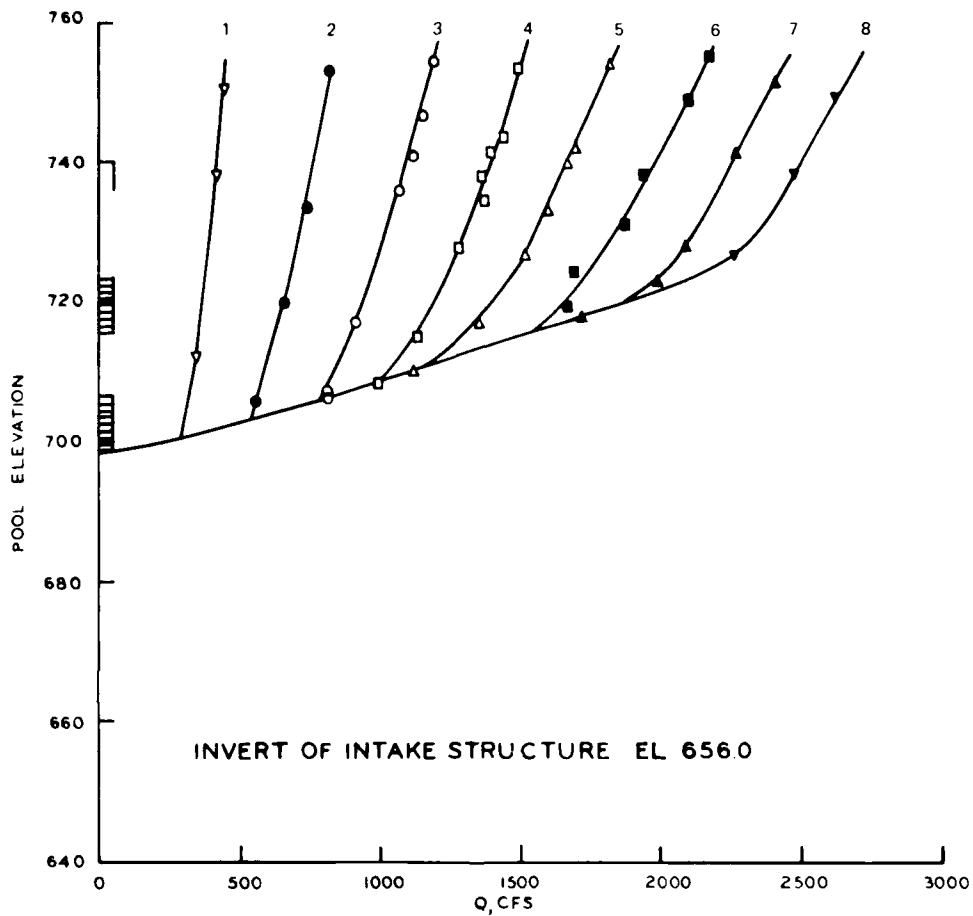

NOTE NUMBER ON CURVE REFERS TO
SERVICE GATE OPENING IN FEET

DISCHARGE RATING CURVES
FOR SELECTIVE WITHDRAWAL
RISER
UPPER AND LOWER INTAKES OPEN

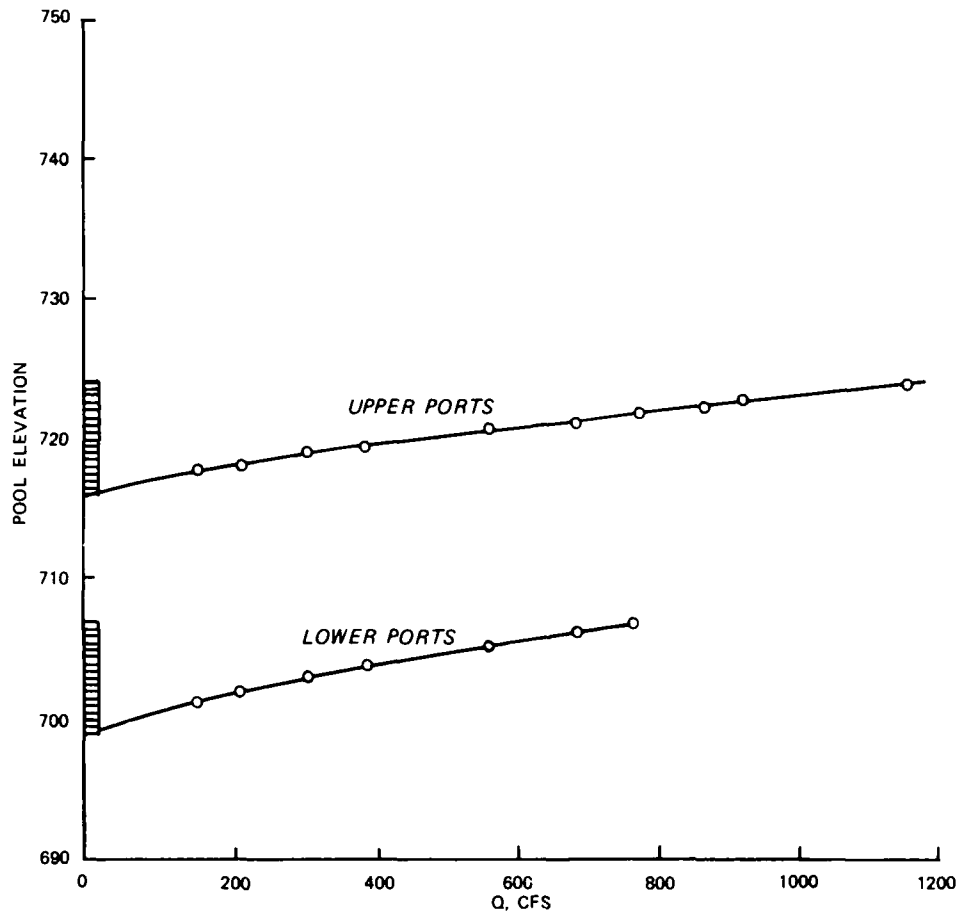

WEIR FLOW

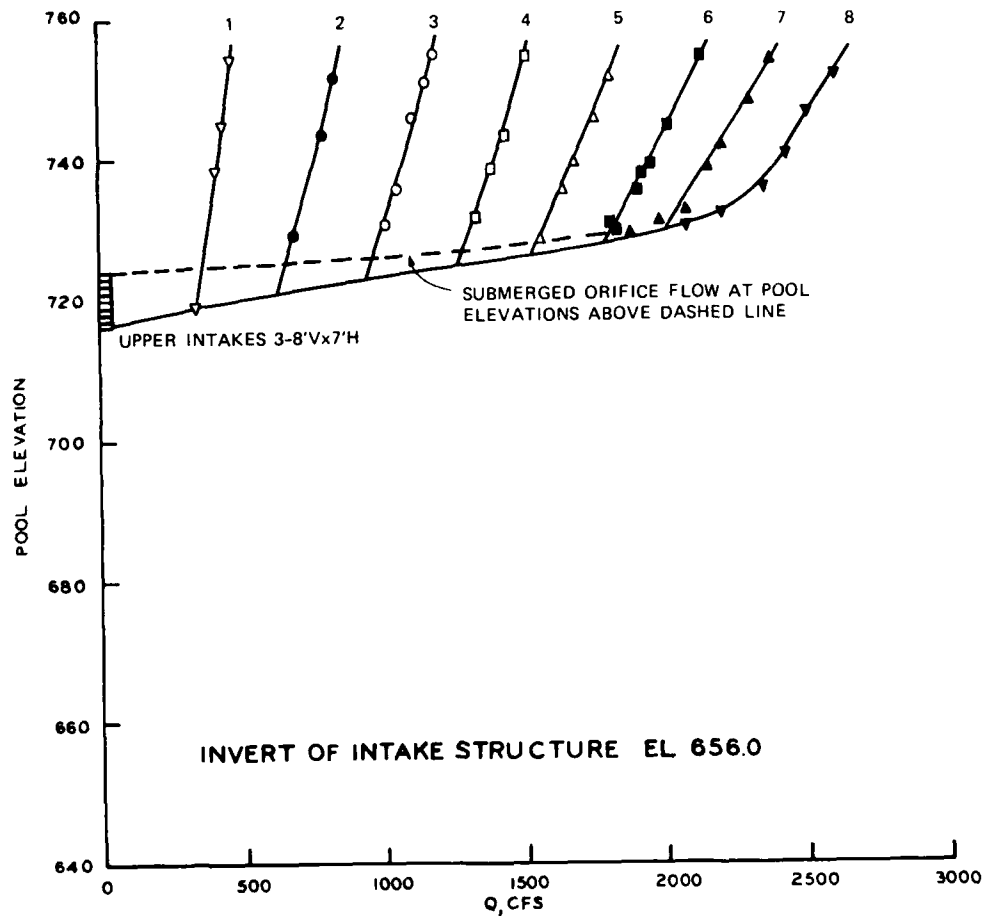

LEGEND

--- POOL ELEVATION AT WHICH WATER SURFACE
INSIDE RISER IS AT THE TOP OF INTAKE(EL724.0)

NOTE: NUMBER ON CURVE REFERS TO
SERVICE GATE OPENING IN FEET.

**SUBMERGED ORIFICE FLOW
UPPER INTAKES OPEN**

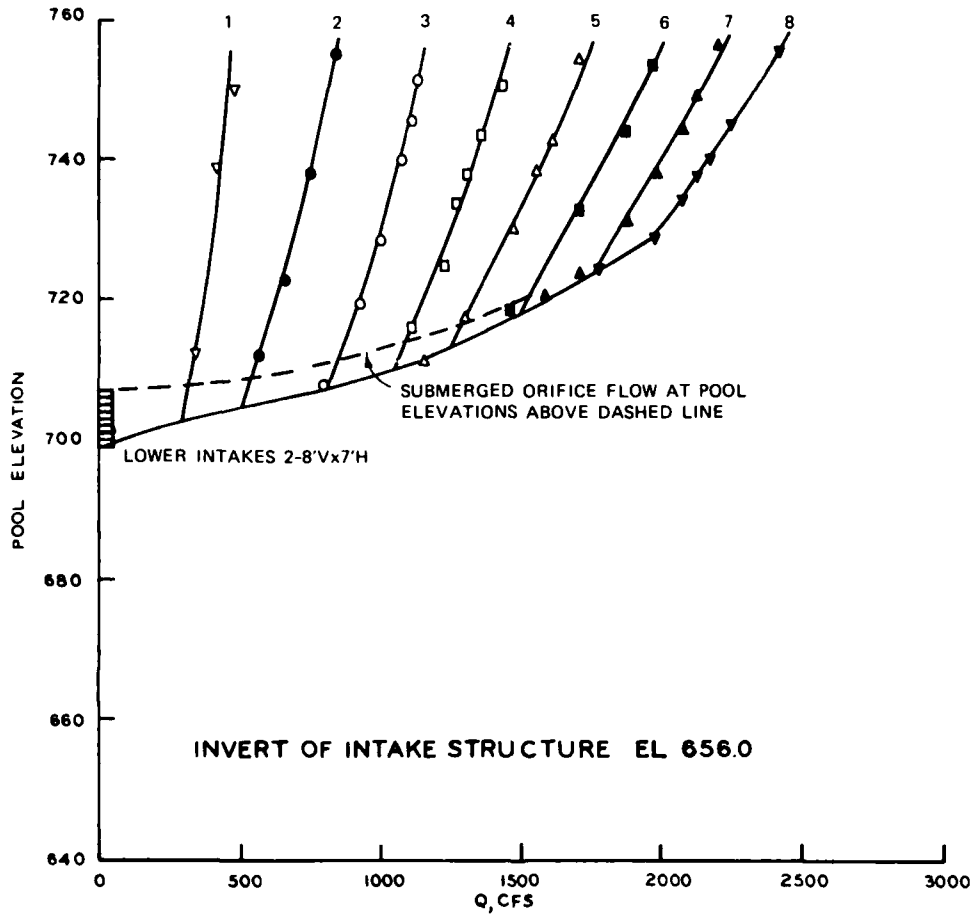

LEGEND

-- POOL ELEVATION AT WHICH WATER SURFACE
INSIDE RISER IS AT THE TOP OF INTAKE (EL707.0)

NOTE: NUMBER ON CURVE REFERS TO
SERVICE GATE OPENING IN FEET

**SUBMERGED ORIFICE FLOW
LOWER INTAKES OPEN**

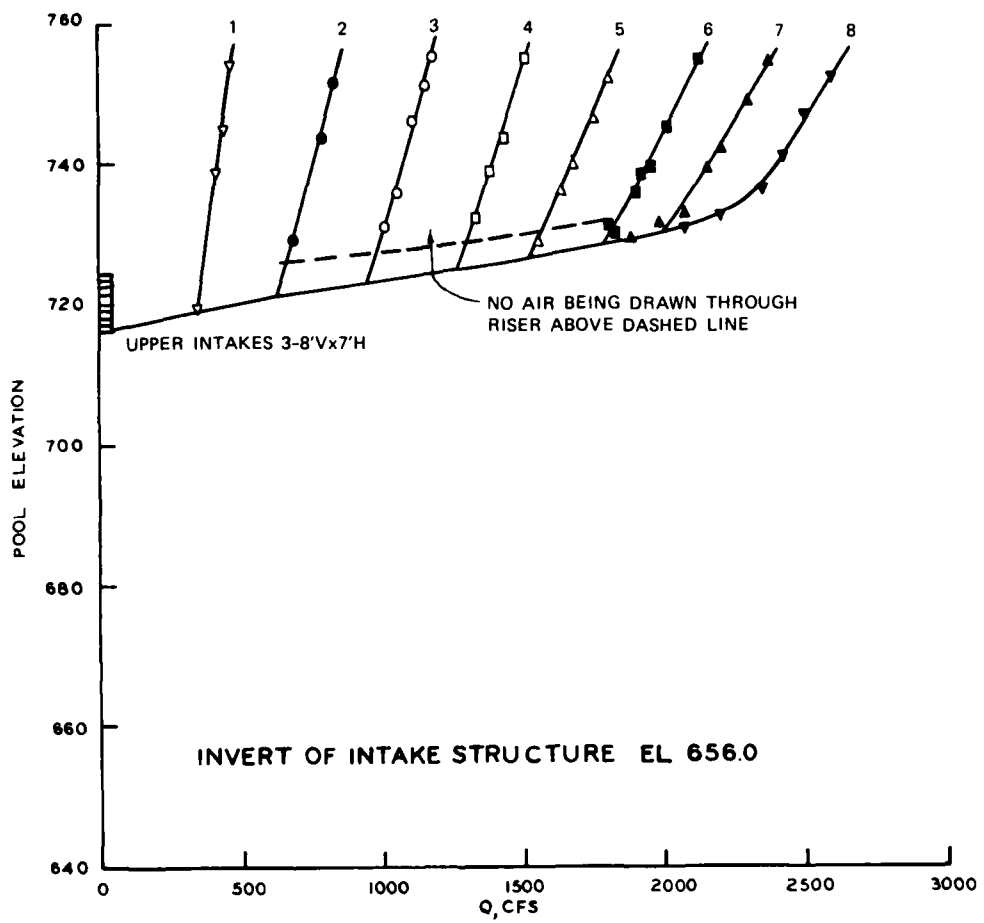

LEGEND

--- POOL ELEVATION AT WHICH AIR BEGINS TO BE TRANSPORTED THROUGH RISER.

NOTE: NUMBER ON CURVE REFERS TO SERVICE GATE OPENING IN FEET

AIR TRANSPORT THROUGH SELECTIVE WITHDRAWAL RISER
UPPER INTAKES OPEN

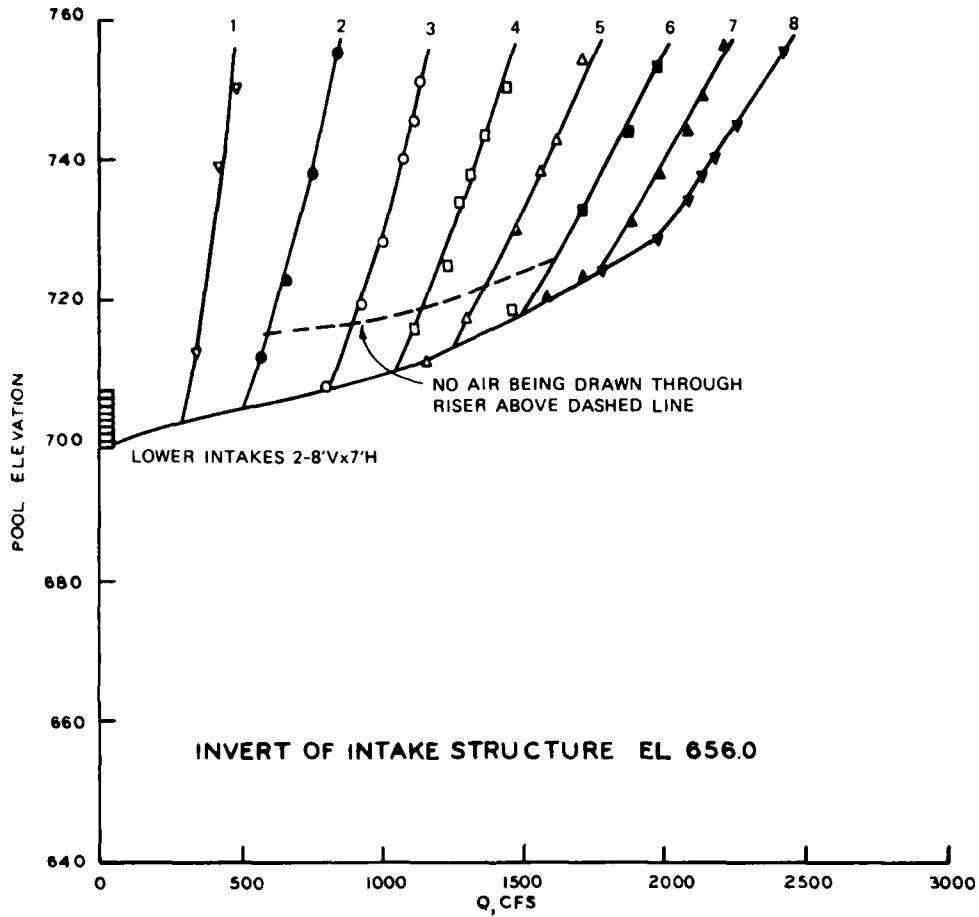

LEGEND

--- POOL ELEVATION AT WHICH AIR BEGINS TO BE TRANSPORTED THROUGH RISER.

NOTE: NUMBER ON CURVE REFERS TO SERVICE GATE OPENING IN FEET.

AIR TRANSPORT THROUGH
SELECTIVE WITHDRAWAL
RISER

LOWER INTAKES OPEN

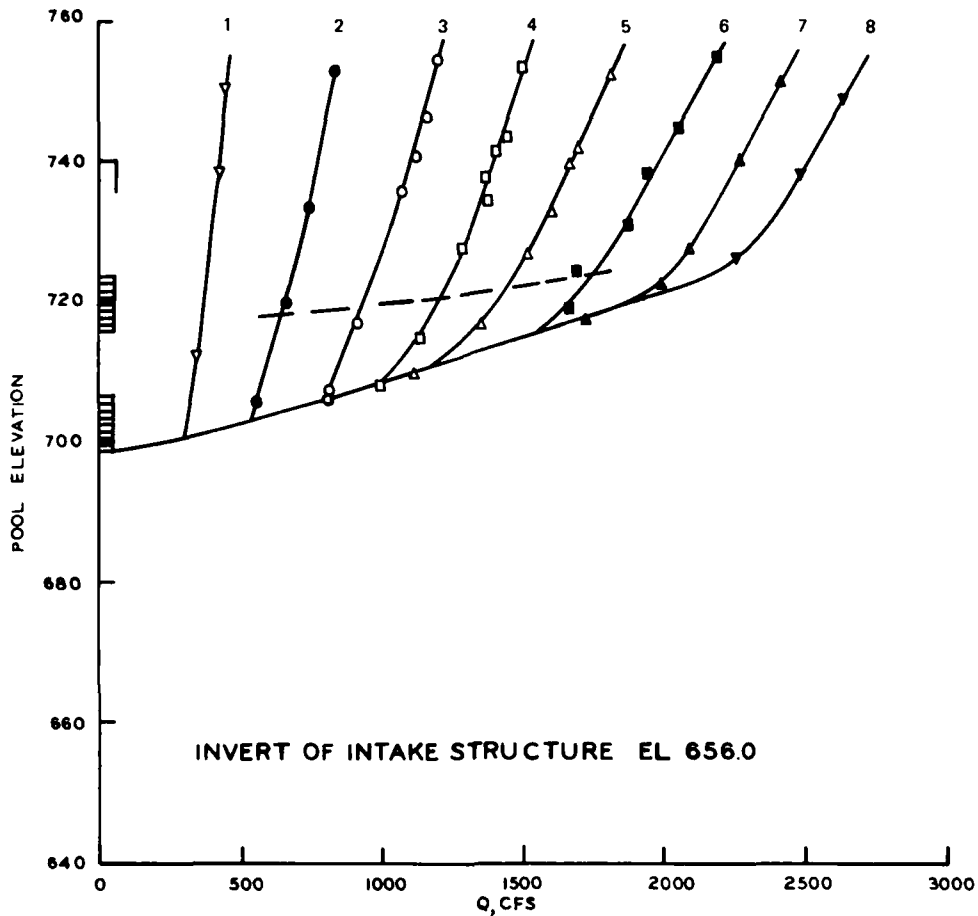

INVERT OF INTAKE STRUCTURE EL 656.0

LEGEND

--- POOL ELEVATION AT WHICH AIR BEGINS TO BE TRANSPORTED THROUGH RISER.

NOTE NUMBER ON CURVE REFERS TO SERVICE GATE OPENING IN FEET.

**AIR TRANSPORT THROUGH
SELECTIVE WITHDRAWAL
RISER
UPPER AND LOWER
INTAKES OPEN**

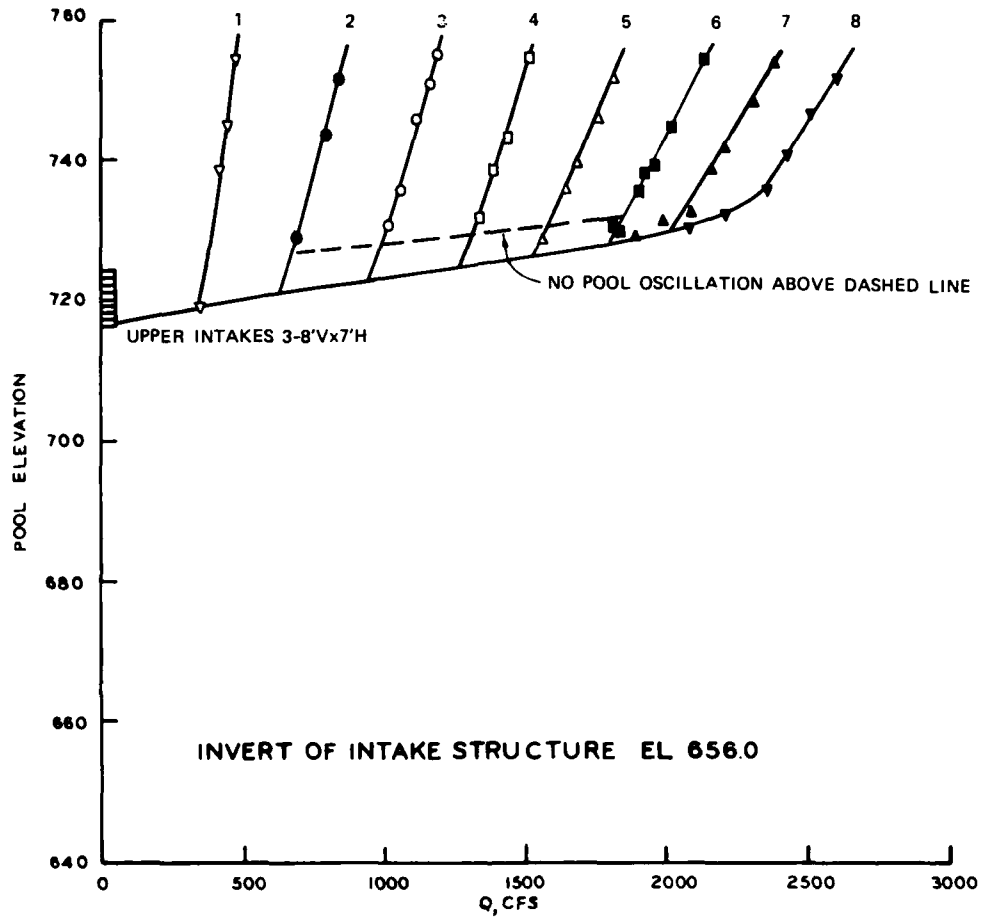

LEGEND

--- POOL ELEVATION AT WHICH OSCILLATION STARTS DUE TO FLOW CONDITIONS IN RISER.

NOTE: NUMBER ON CURVE REFERS TO SERVICE GATE OPENING IN FEET.

**POOL OSCILLATION
UPPER INTAKES OPEN**

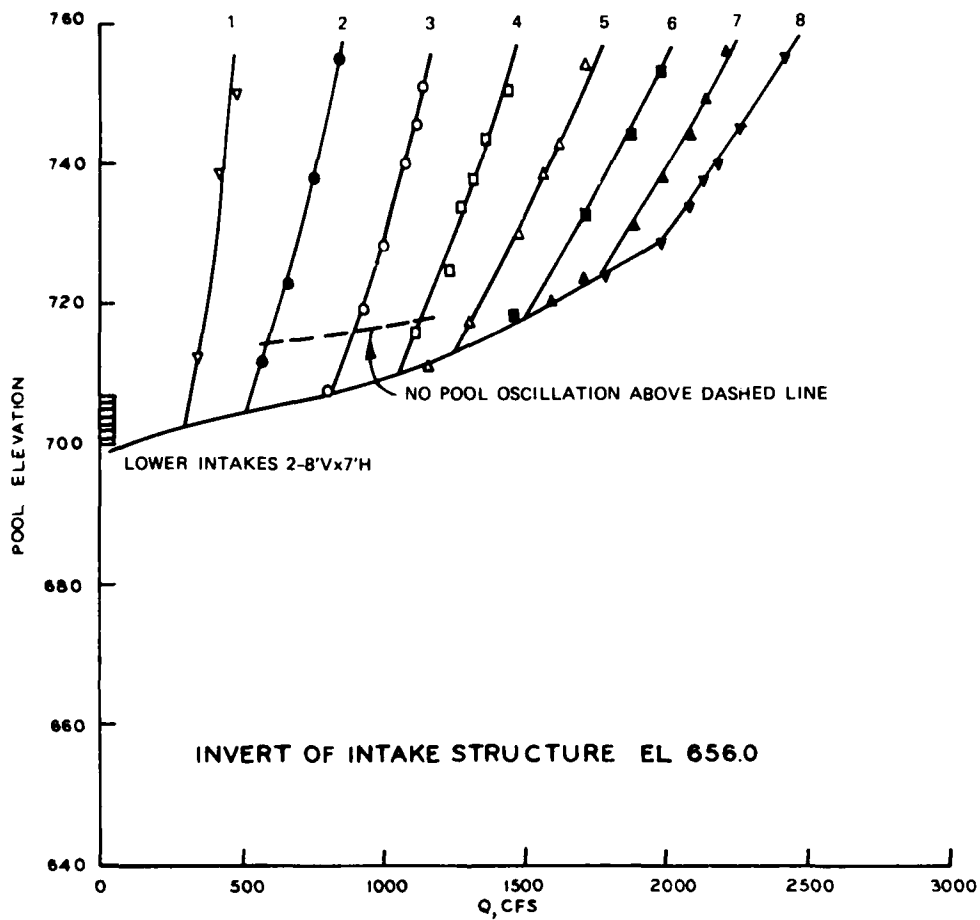

LEGEND

--- POOL ELEVATION AT WHICH OSCILLATION STARTS
DUE TO FLOW CONDITIONS IN RISER

NOTE: NUMBER ON CURVE REFERS TO
SERVICE GATE OPENING IN FEET.

POOL OSCILLATION
LOWER INTAKES OPEN

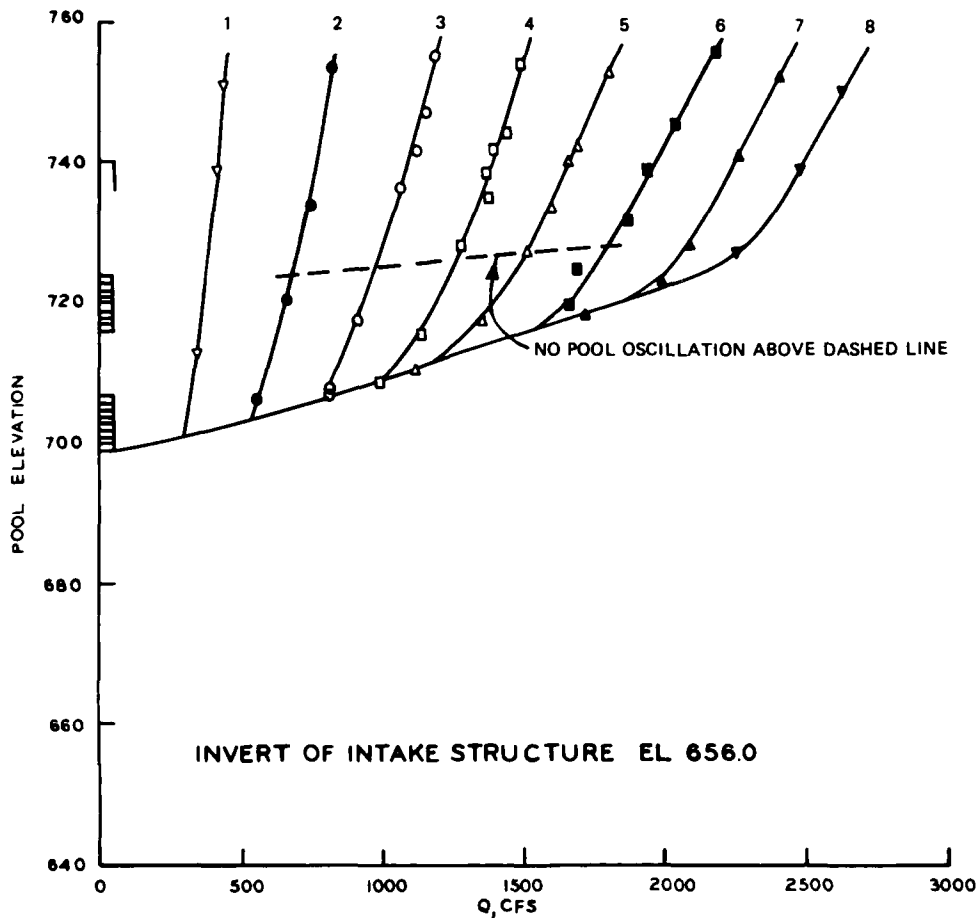

LEGEND

--- POOL ELEVATION AT WHICH OSCILLATION STARTS DUE TO FLOW CONDITIONS IN RISER.

NOTE: NUMBER ON CURVE REFERS TO SERVICE GATE OPENING IN FEET.

POOL OSCILLATION
UPPER AND LOWER
INTAKES OPEN

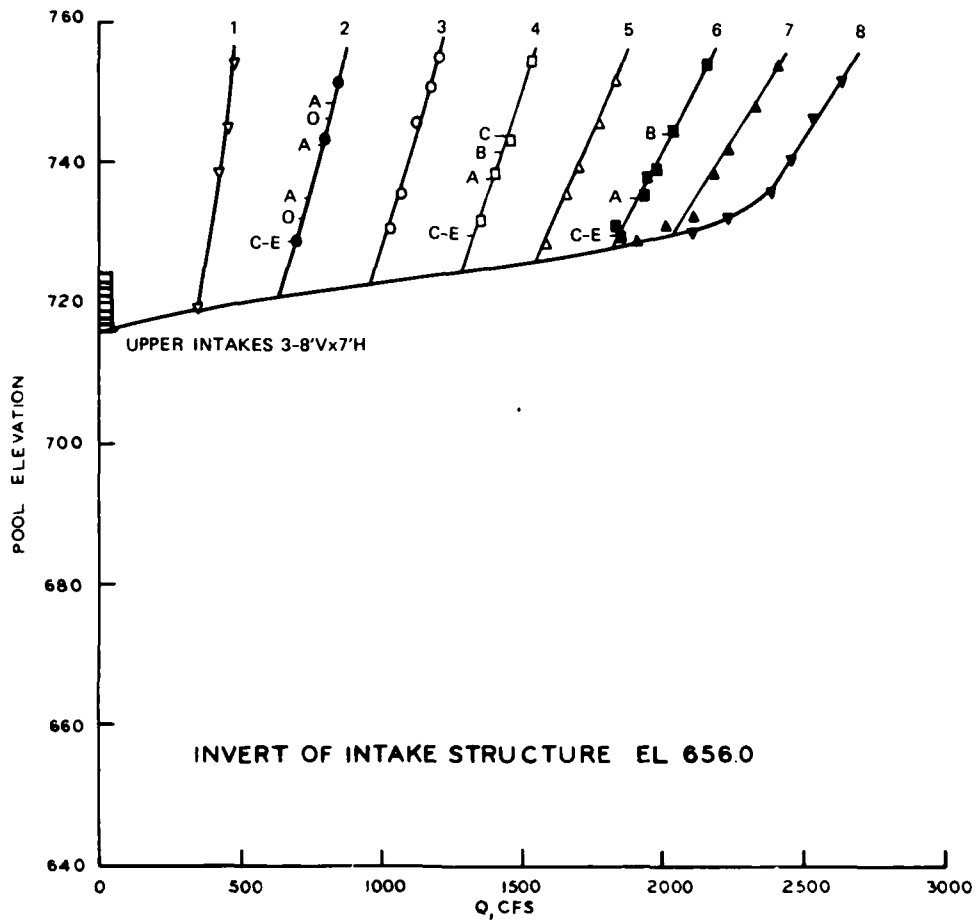

NOTE: NUMBER ON CURVE REFERS TO SERVICE GATE OPENING IN FEET. LETTERS ON CURVES REFER TO STAGE OF VORTEX DEVELOPMENT

VORTEX STUDY
ORIGINAL DESIGN
UPPER INTAKES OPEN

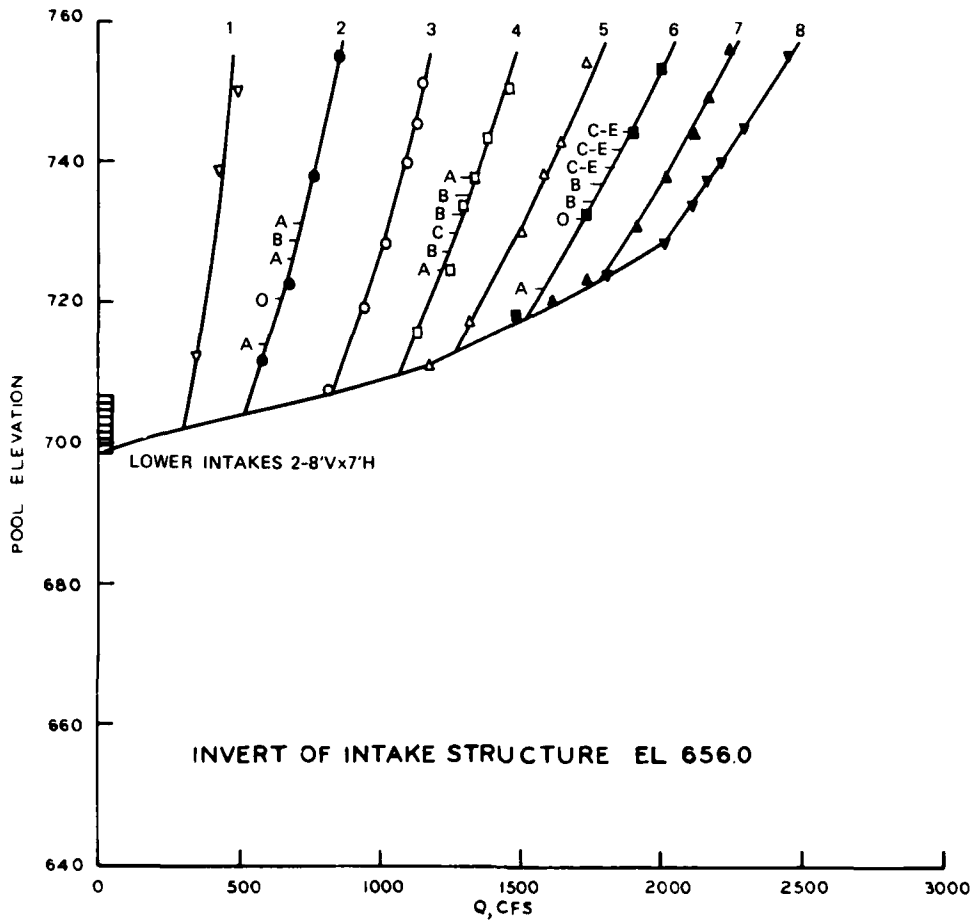

NOTE: NUMBER ON CURVE REFERS TO SERVICE GATE OPENING IN FEET. LETTERS ON CURVES REFER TO STAGE OF VORTEX DEVELOPMENT.

VORTEX STUDY
ORIGINAL DESIGN
LOWER INTAKES OPEN

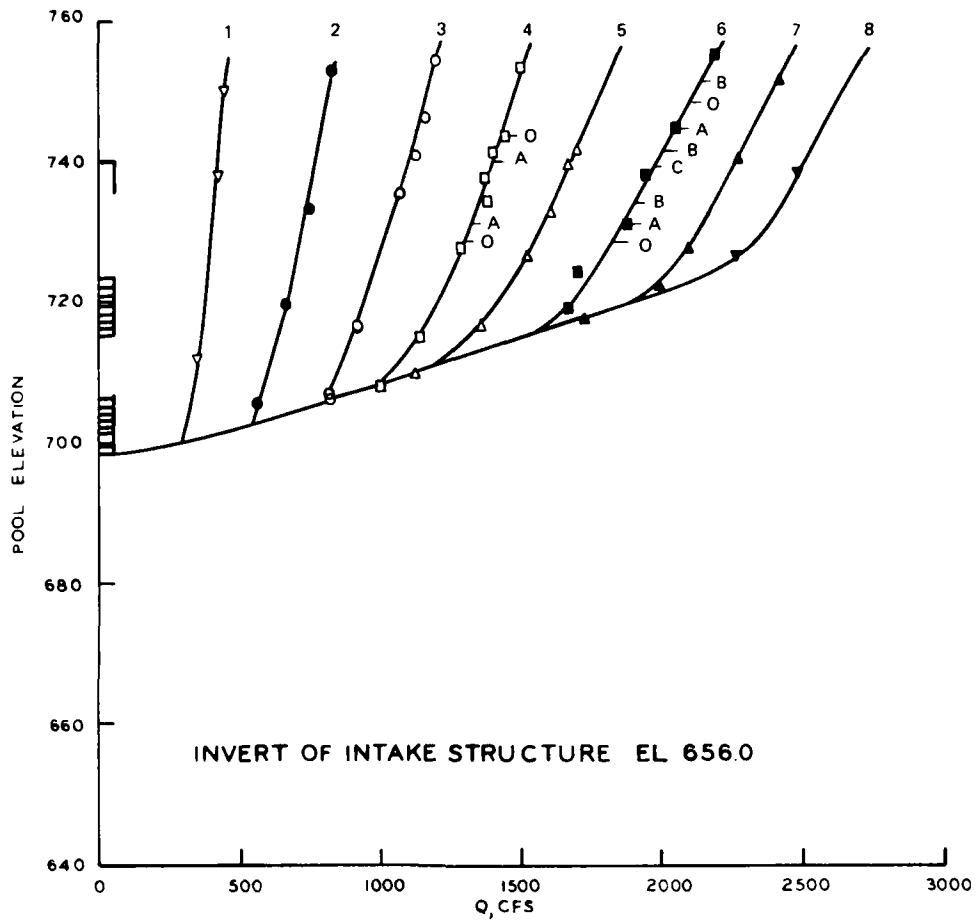

NOTE: NUMBER ON CURVE REFERS TO SERVICE GATE OPENING IN FEET
LETTERS ON CURVES REFER TO STAGE OF VORTEX DEVELOPMENT

VORTEX STUDY
ORIGINAL DESIGN
UPPER AND LOWER INTAKES OPEN

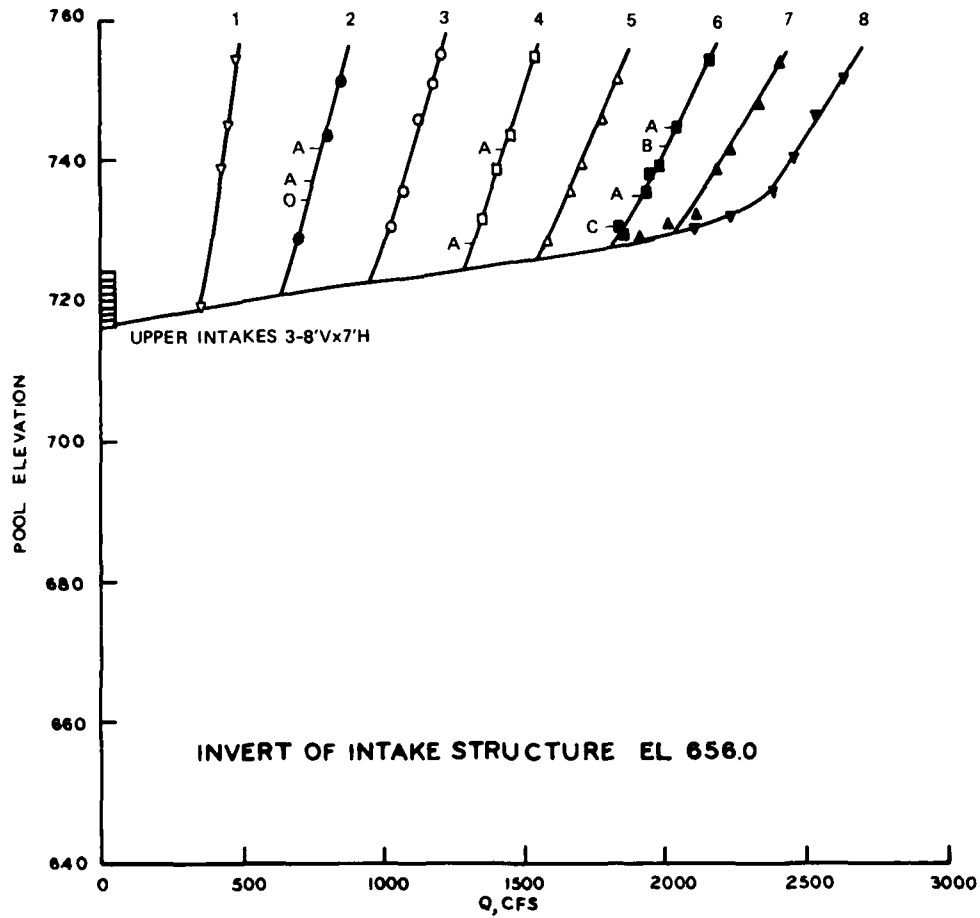

NOTE: NUMBER ON CURVE REFERS TO SERVICE GATE OPENING IN FEET. LETTERS ON CURVES REFER TO STAGE OF VORTEX DEVELOPMENT

VORTEX STUDY
 TYPE 2 APRON 6 FT WIDE
 UPPER INTAKES OPEN

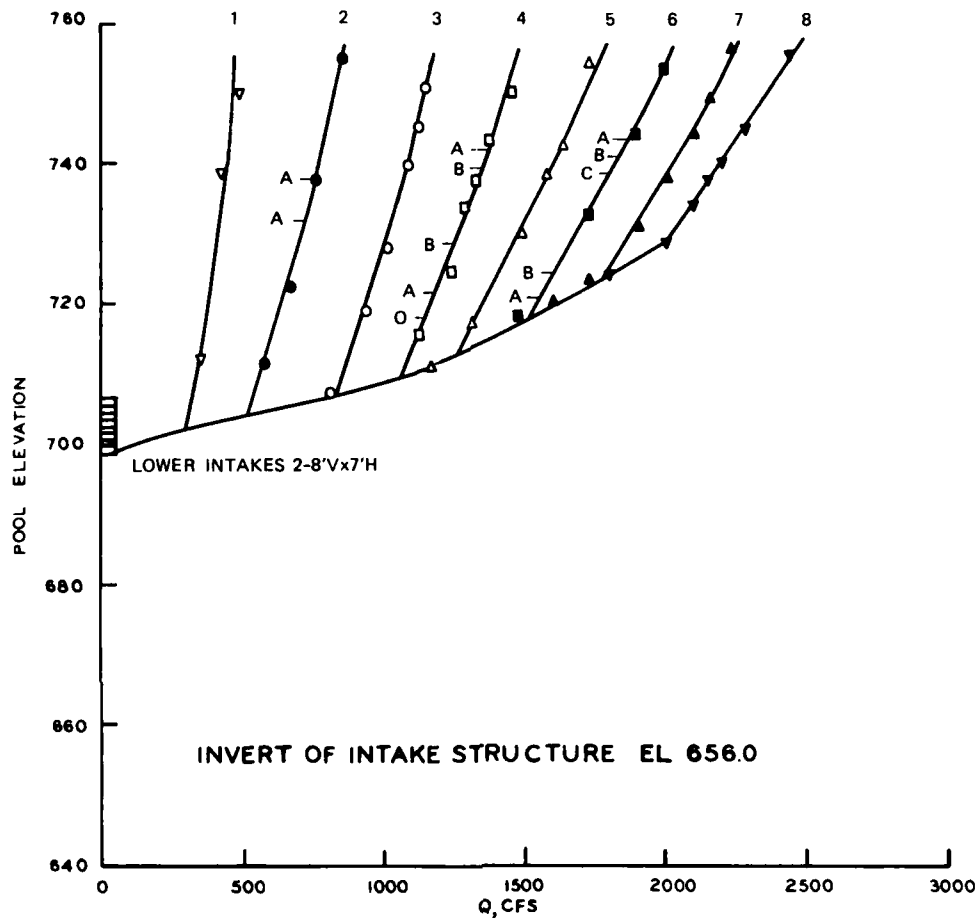

NOTE: NUMBER ON CURVE REFERS TO SERVICE GATE OPENING IN FEET. LETTERS ON CURVES REFER TO STAGE OF VORTEX DEVELOPMENT.

VORTEX STUDY
 TYPE 2 APRON 6 FT WIDE
 LOWER INTAKES OPEN

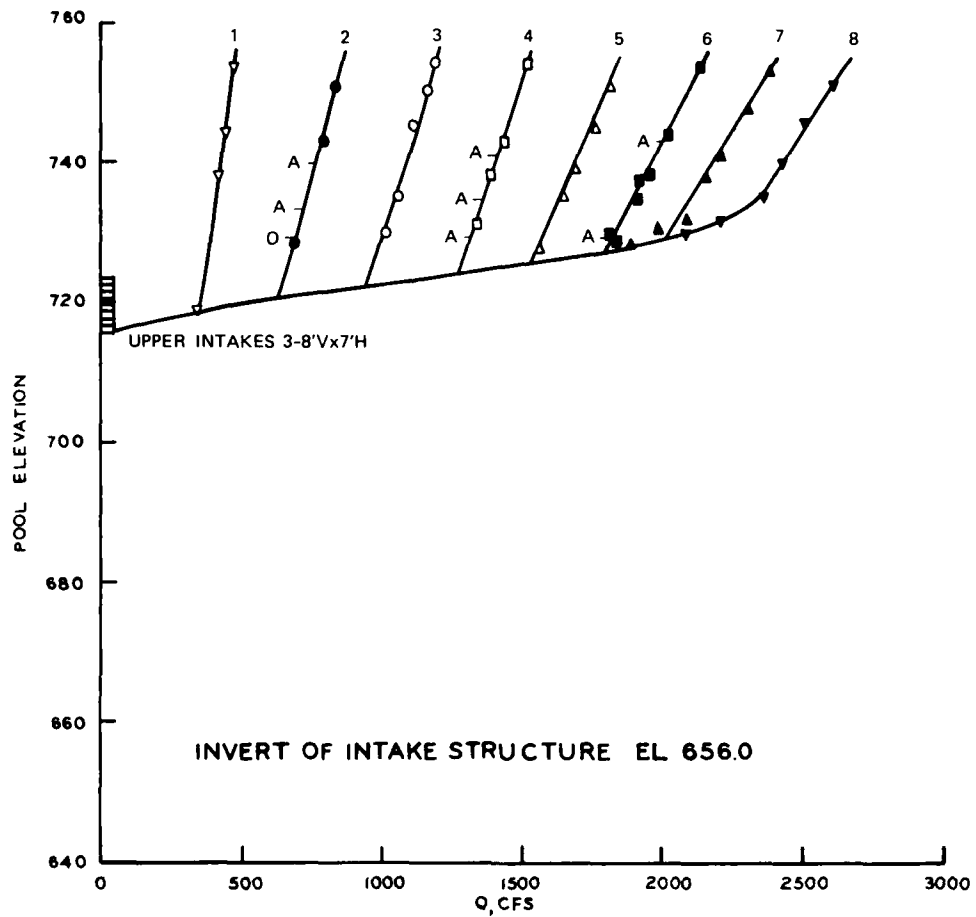

NOTE: NUMBER ON CURVE REFERS TO SERVICE GATE OPENING IN FEET. LETTERS ON CURVES REFER TO STAGE OF VORTEX DEVELOPMENT.

VORTEX STUDY
 TYPE 3 APRON 6 FT WIDE
 UPPER INTAKES OPEN

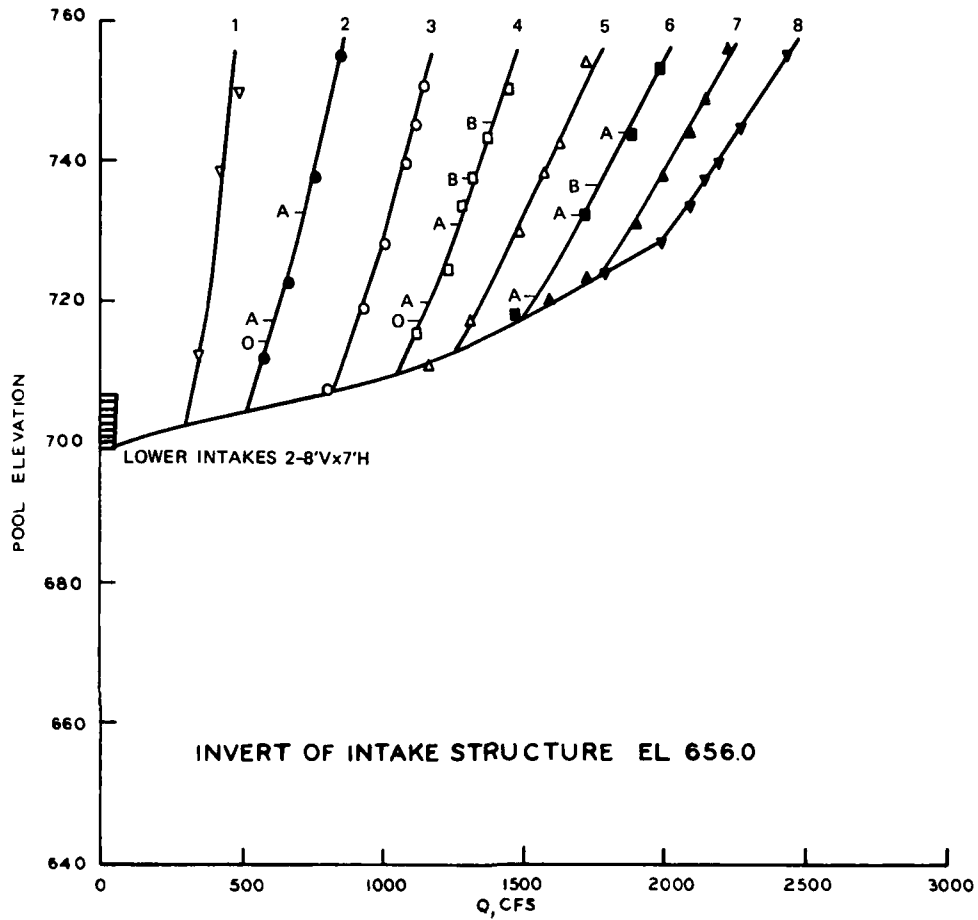

NOTE: NUMBER ON CURVE REFERS TO SERVICE GATE OPENING IN FEET. LETTERS ON CURVES REFER TO STAGE OF VORTEX DEVELOPMENT.

VORTEX STUDY
 TYPE 3 APRON 6 FT WIDE
 LOWER INTAKES OPEN

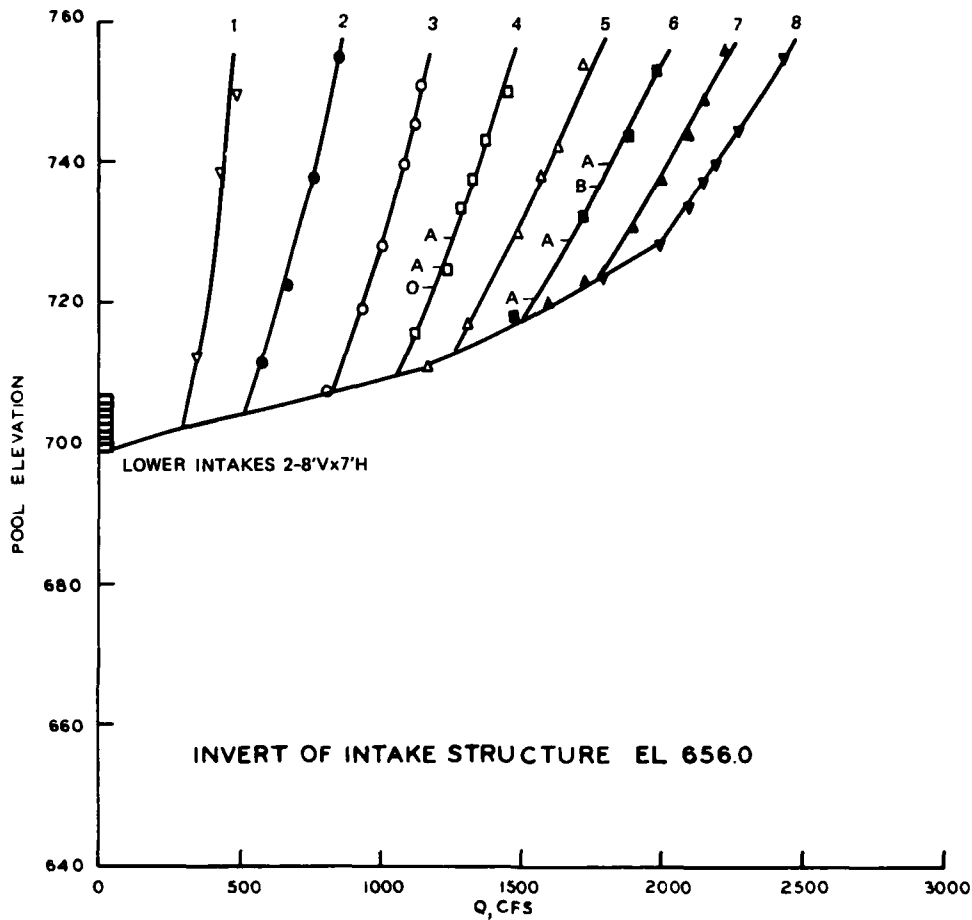

NOTE: NUMBER ON CURVE REFERS TO SERVICE GATE OPENING IN FEET. LETTERS ON CURVES REFER TO STAGE OF VORTEX DEVELOPMENT.

VORTEX STUDY
 TYPE 4 APRON 8 FT WIDE
 LOWER INTAKES OPEN

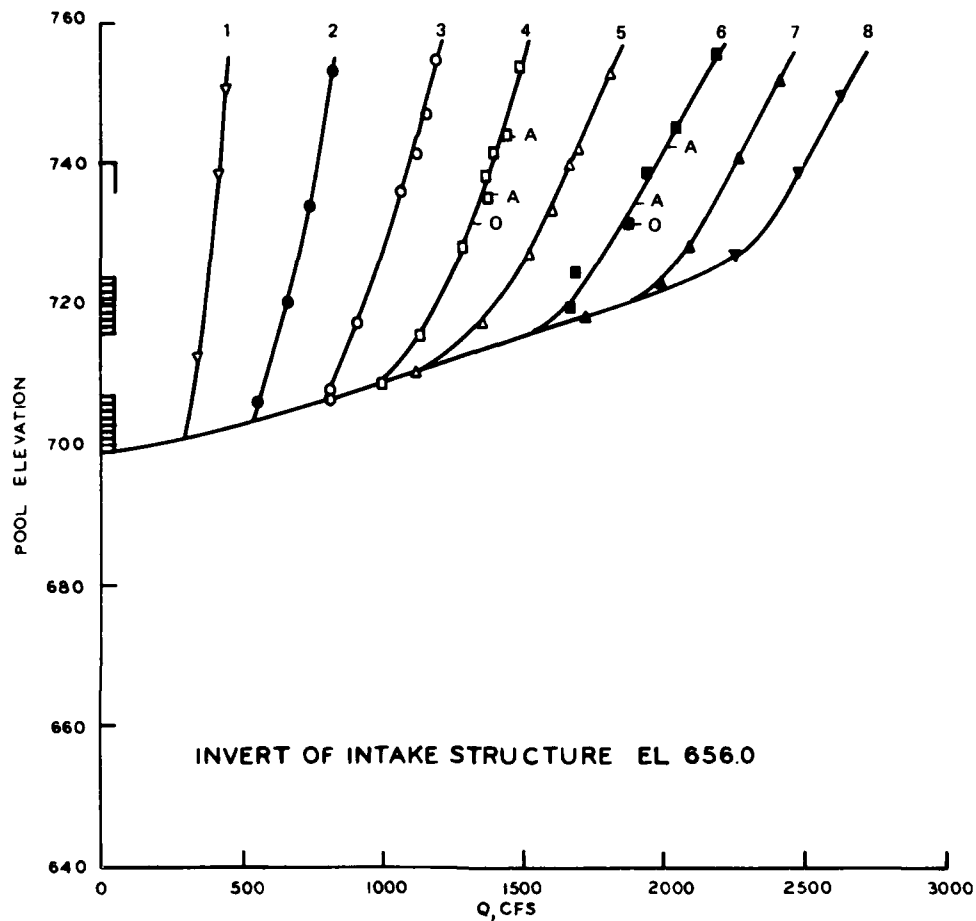

NOTE: NUMBER ON CURVE REFERS TO SERVICE GATE OPENING IN FEET. LETTERS ON CURVES REFER TO STAGE OF VORTEX DEVELOPMENT.

VORTEX STUDY
 TYPE 3 APRON ON UPPER INTAKES
 TYPE 4 APRON ON LOWER INTAKES
 UPPER AND LOWER INTAKES OPEN

PEZ. NO.	ELEVATION	PEZ. NO.	ELEVATION
13	677.3	19	672.9
14	680.9	20	672.4
15	680.8	21	672.4
16	670.8	22	657.3
17	683.7		
18	672.8		
19	672.9		
20	674.8		
21	674.9		
22	657.3		

NOTE: PIEZOMETERS 13, 16, 19, & 20 ARE LOCATED 3' DOWNSTREAM OF BREAK. LOCATED 3' UPSTREAM OF BREAK. LOCATED 3' DOWNSTREAM OF BREAK.

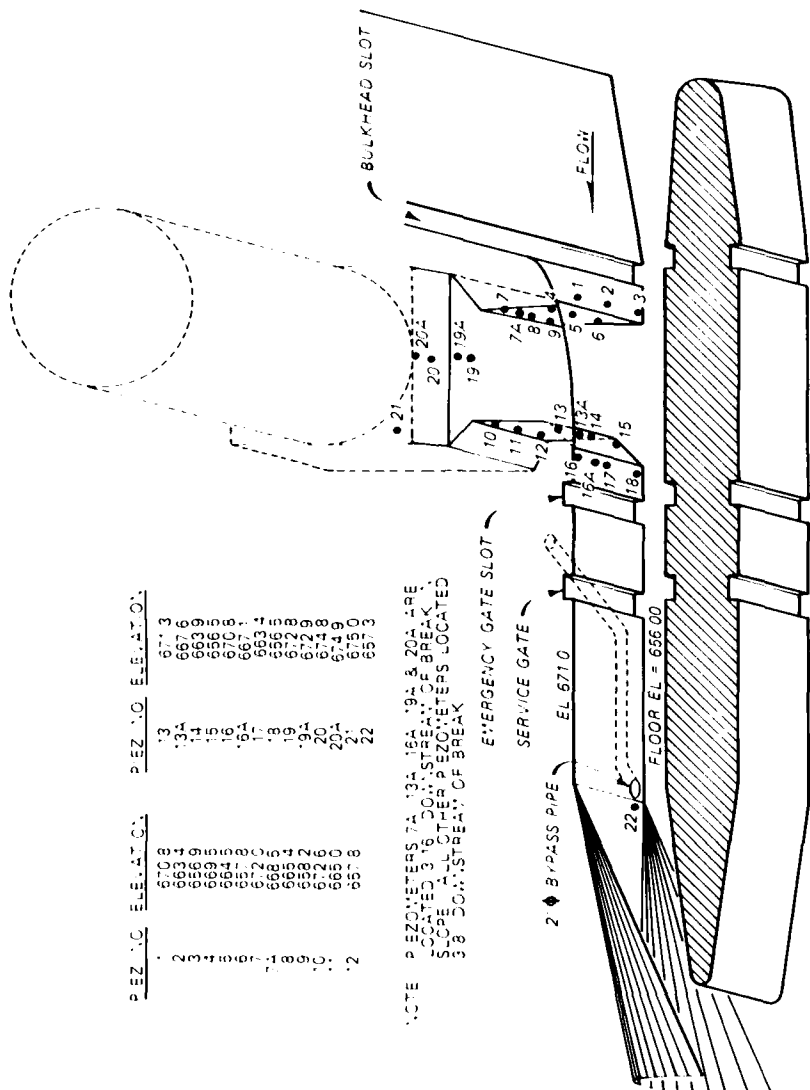

PIEZOMETER LOCATIONS

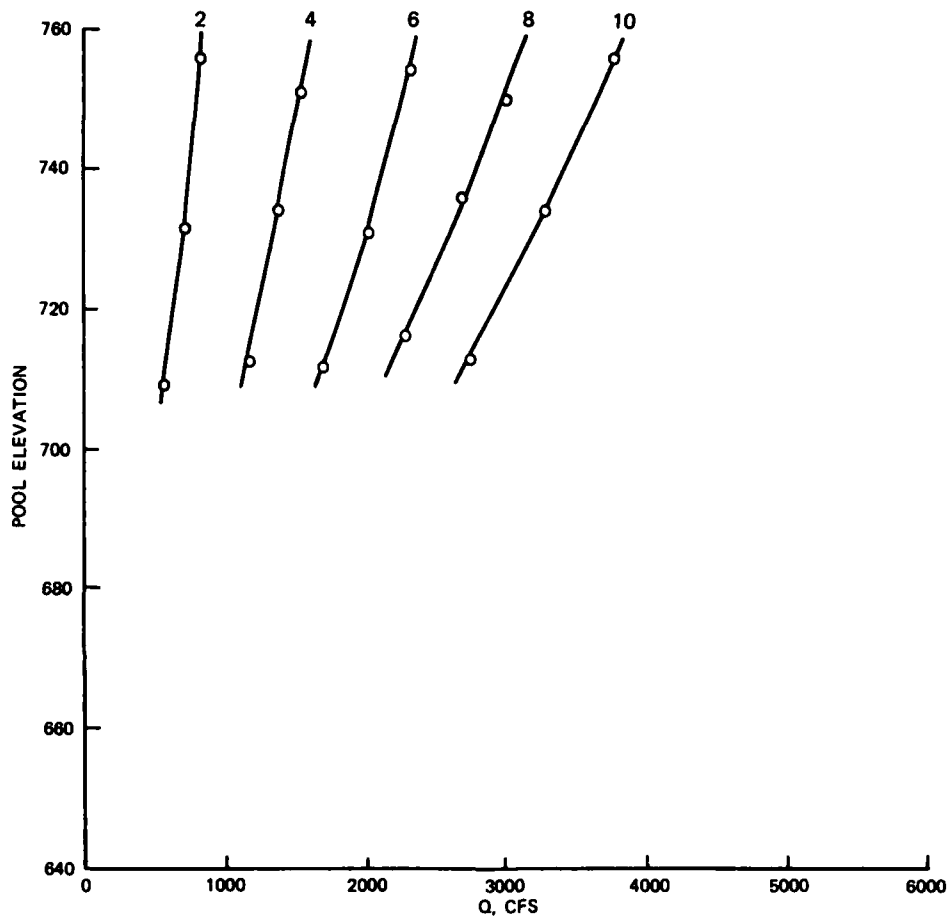

NOTE: NUMBER ON CURVE REFERS TO LEFT SERVICE GATE OPENING IN FEET. RIGHT SERVICE GATE CLOSED.

DISCHARGE RATING CURVES
FOR LEFT SERVICE GATE
FLOOD-CONTROL FLOW

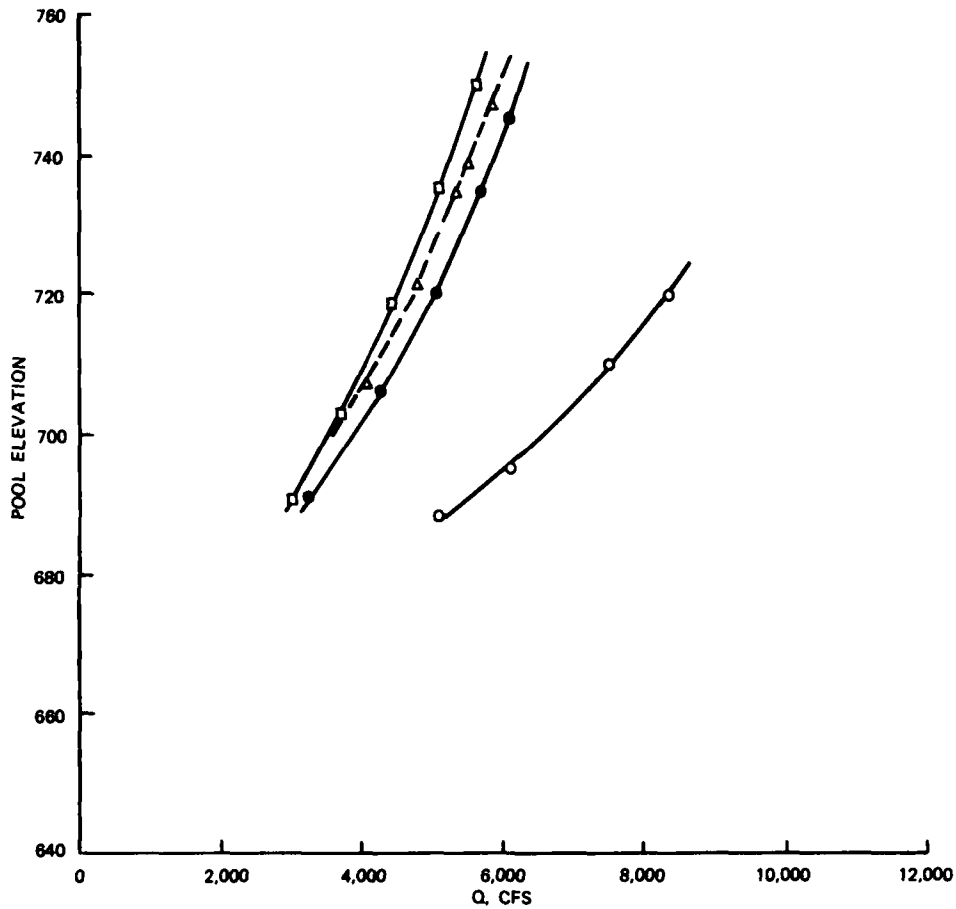

LEGEND

- BOTH SERVICE GATES OPEN WITH RISER GATES CLOSED
- LEFT SERVICE GATE OPEN
- ◻ RIGHT SERVICE GATE OPEN WITH ALL RISER GATES OPEN
- ▲ RIGHT SERVICE GATE OPEN WITH RISER GATES CLOSED

**DISCHARGE RATING CURVES
FLOOD-CONTROL FLOW
SERVICE GATES FULLY OPEN**

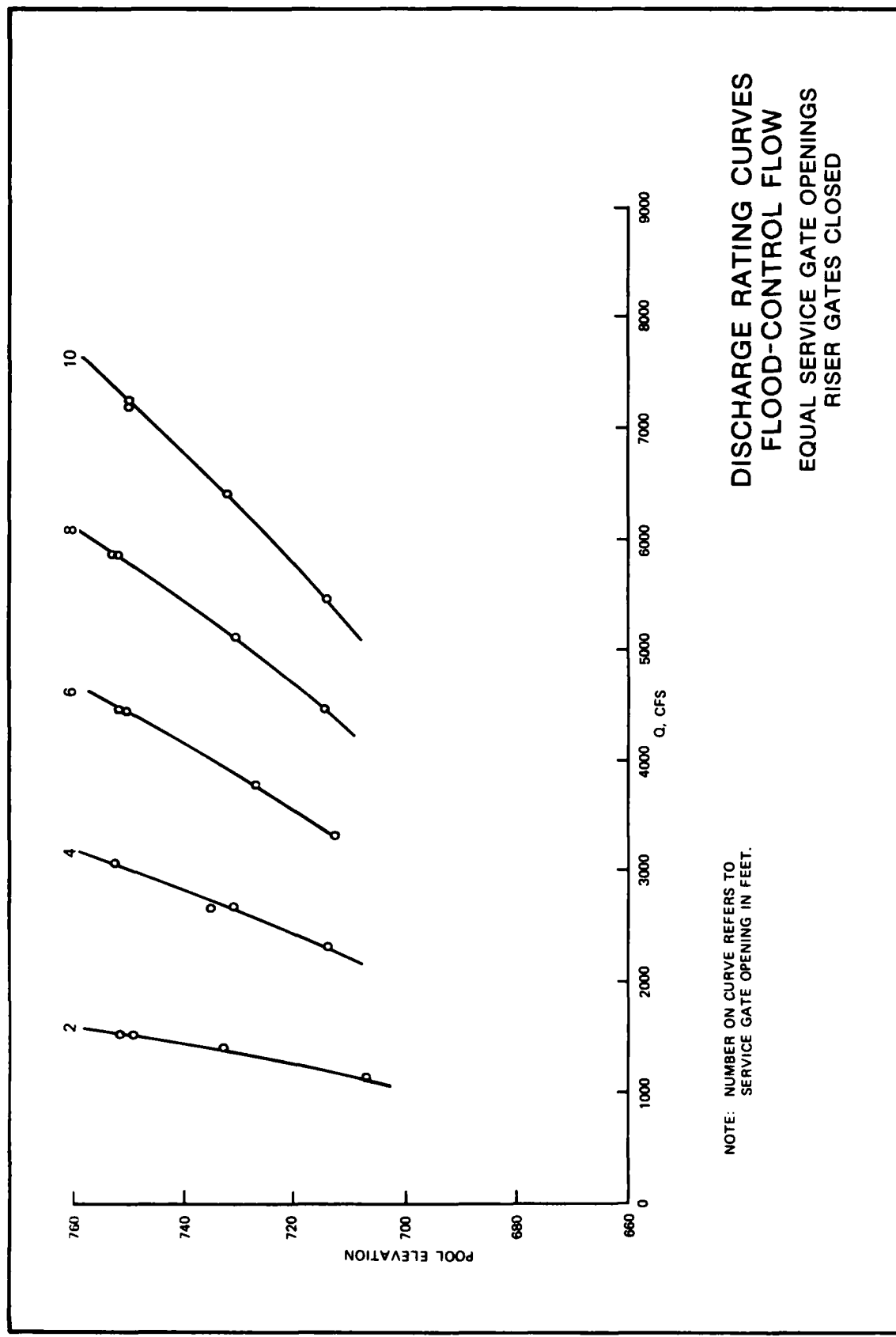

NOTE: NUMBER ON CURVE REFERS TO SERVICE GATE OPENING IN FEET.

DISCHARGE RATING CURVES
FLOOD-CONTROL FLOW
EQUAL SERVICE GATE OPENINGS
RISER GATES CLOSED

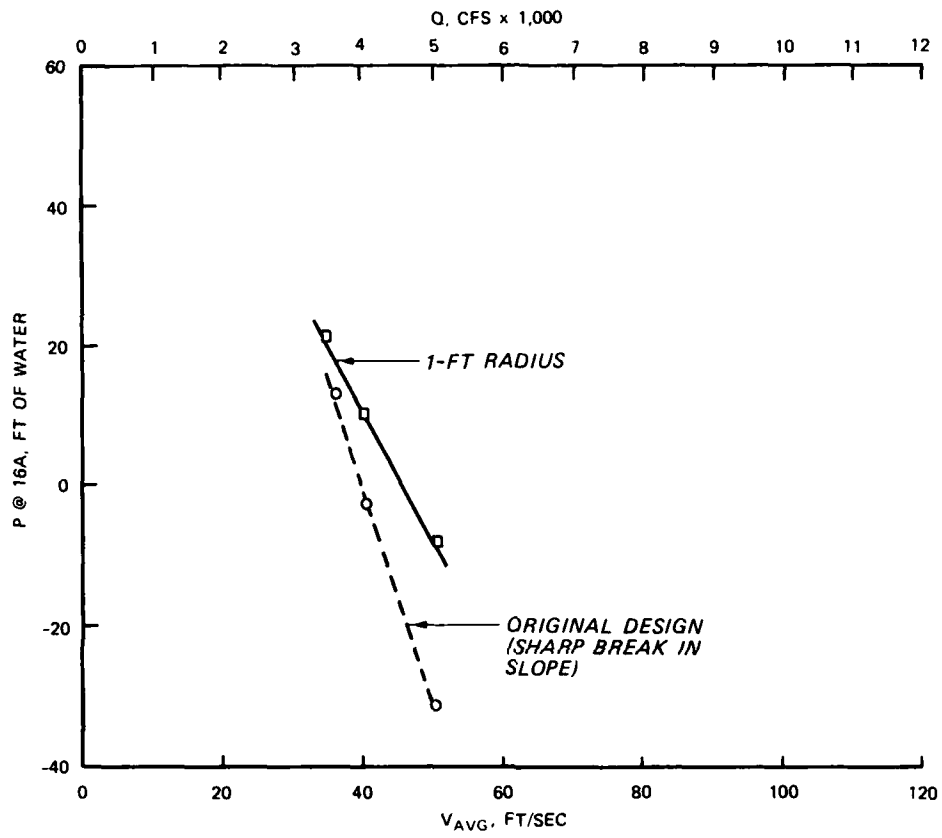

PRESSURE PIEZOMETER 16A
 VS AVERAGE VELOCITY IN
 FLOOD CONTROL PASSAGE
 RISER CLOSED

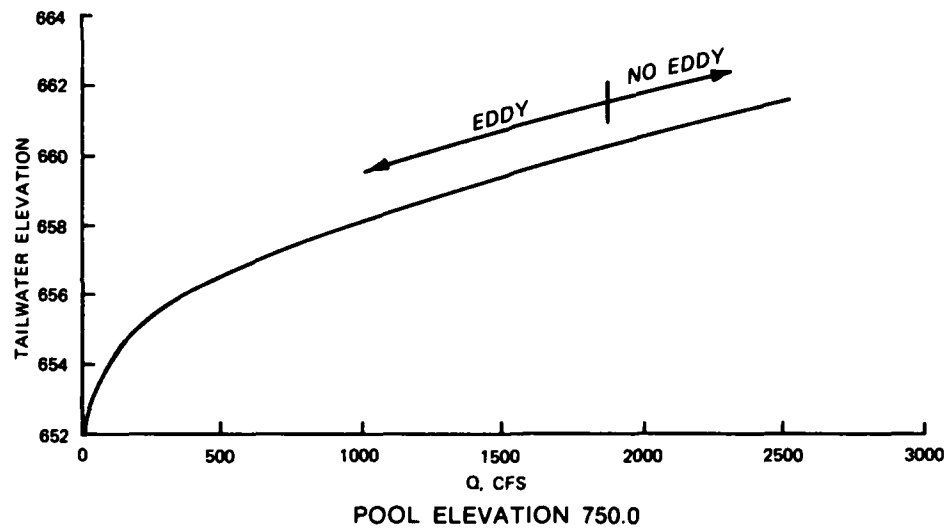
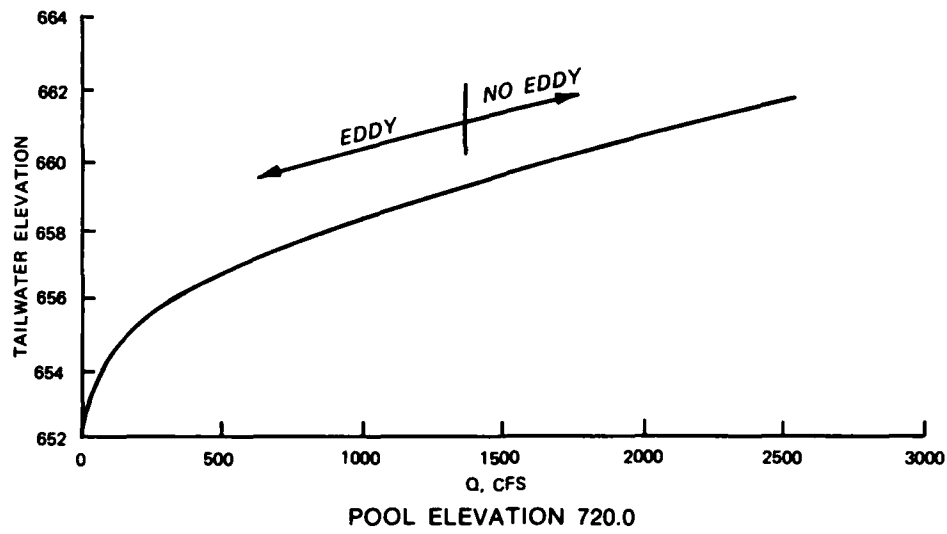

STILLING BASIN PERFORMANCE
 EQUAL SERVICE GATE OPENING
 TAILWATER CURVE BASED ON
 JULY 1971 STUDY

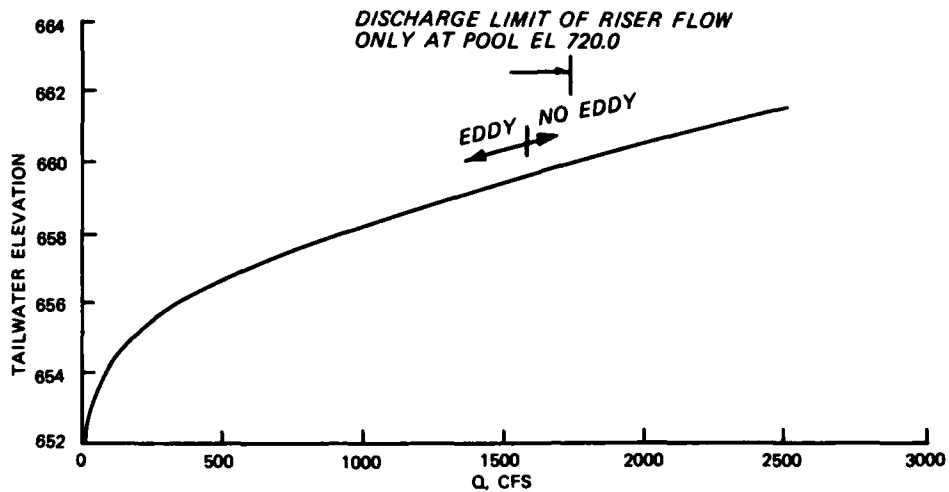

POOL ELEVATION 720.0

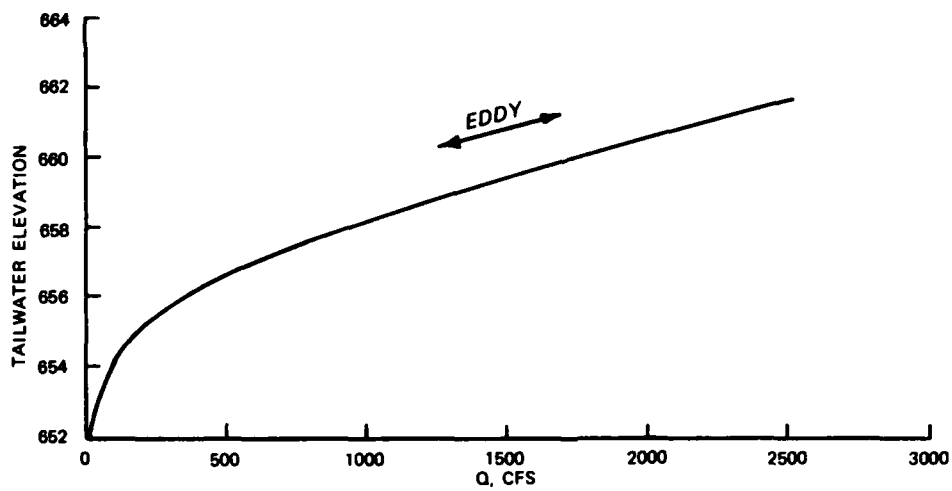

POOL ELEVATION 750.0

STILLING BASIN PERFORMANCE
 RISER FLOW ONLY
 TAILWATER CURVE BASED ON
 JULY 1971 STUDY

END

2-87.

DTIC