

AD-A176 590

2

NAVAL POSTGRADUATE SCHOOL Monterey, California



DTIC
ELECTE
FEB 11 1987
S D D

THESIS

DESIGN OF THE DIGITAL SATELLITE LINK INTERFACE
FOR A SYSTEM THAT DETECTS
THE PRECURSORY ELECTROMAGNETIC EMISSIONS
ASSOCIATED WITH EARTHQUAKES

by

Kevin C. Ebel
December 1986

Thesis Advisor:

R. W. Adler

Approved for public release; distribution is unlimited

DTIC FILE COPY

87 2 10 016

DTIC

UNCLASSIFIED

1 FEB 1 1953

D

REPORT DOCUMENTATION PAGE

1a. REPORT SECURITY CLASSIFICATION unclassified		1b. RESTRICTIVE MARKINGS	
SECURITY CLASSIFICATION AUTHORITY		3. DISTRIBUTION / AVAILABILITY OF REPORT Approved for public release; distribution is unlimited.	
2b. DECLASSIFICATION / DOWNGRADING SCHEDULE		4. PERFORMING ORGANIZATION REPORT NUMBER(S)	
4. PERFORMING ORGANIZATION REPORT NUMBER(S)		5. MONITORING ORGANIZATION REPORT NUMBER(S)	
6a. NAME OF PERFORMING ORGANIZATION Naval Postgraduate School	6b. OFFICE SYMBOL (if applicable) 62	7a. NAME OF MONITORING ORGANIZATION Naval Postgraduate School	
6c. ADDRESS (City, State, and ZIP Code) Monterey, California 93943-5000		7b. ADDRESS (City, State, and ZIP Code) Monterey, California 93943-5000	
8a. NAME OF FUNDING / SPONSORING ORGANIZATION	8b. OFFICE SYMBOL (if applicable)	9. PROCUREMENT INSTRUMENT IDENTIFICATION NUMBER	
8c. ADDRESS (City, State, and ZIP Code)		10. SOURCE OF FUNDING NUMBERS	
		PROGRAM ELEMENT NO.	PROJECT NO.
		TASK NO.	WORK UNIT ACCESSION NO.
11. TITLE (Include Security Classification) DESIGN OF THE DIGITAL SATELLITE LINK INTERFACE FOR A SYSTEM THAT DETECTS THE PRECURSORY ELECTROMAGNETIC EMISSIONS ASSOCIATED WITH EARTHQUAKES			
12. PERSONAL AUTHOR(S) Ebel, Kevin			
TYPE OF REPORT Master's Thesis	13b. TIME COVERED FROM TO	14. DATE OF REPORT (Year, Month, Day) 1986 December	15. PAGE COUNT 106
16. SUPPLEMENTARY NOTATION			
17. COSATI CODES		18. SUBJECT TERMS (Continue on reverse if necessary and identify by block number)	
FIELD	GROUP	Noise Measurement, Electromagnetic Radiation from Earthquakes, Digital Satellite Link Interface for sensor.	
19. ABSTRACT (Continue on reverse if necessary and identify by block number)			
<p>The design, construction and implementation of a computer controlled radio frequency (RF) noise measurement and recording system in the 30.45 MHz and 150.MHz range and the interfacing of this system to a digital satellite link is presented. Earthquake prediction by the use of various physical precursors and the specific use of electromagnetic emissions in the RF range as a precursor to future earthquake activity is described.</p> <p><i>Keywords include:</i></p> <p><i>(Noise)</i></p>			
20. DISTRIBUTION / AVAILABILITY OF ABSTRACT <input checked="" type="checkbox"/> UNCLASSIFIED/UNLIMITED <input type="checkbox"/> SAME AS RPT <input type="checkbox"/> OTIC USERS		21. ABSTRACT SECURITY CLASSIFICATION unclassified	
NAME OF RESPONSIBLE INDIVIDUAL R. W. Adler		22b. TELEPHONE (Include Area Code) 408-646-2352	22c. OFFICE SYMBOL 62AB

Approved for public release; distribution is unlimited.

Design of the Digital Satellite Link Interface
for a System that Detects
the Precursory Electromagnetic Emissions
Associated With Earthquakes

by

Kevin C. Ebel
Lieutenant, United States Navy
B.S., University of Florida, 1977

Submitted in partial fulfillment of the
requirements for the degree of

MASTER OF SCIENCE IN ELECTRICAL ENGINEERING

from the

NAVAL POSTGRADUATE SCHOOL
December 1986

Author:

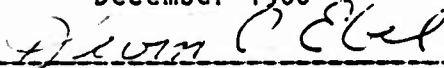

Kevin C. Ebel

Approved by:



R. W. Adler, Thesis Advisor

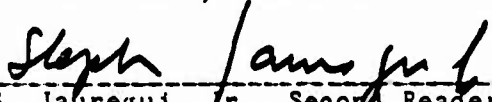

S. Jauregui, Jr., Second Reader



Harriett B. Rigas, Chairman, Department of
Electrical and Computer Engineering



John N. Dyer,
Dean of Science and Engineering

ABSTRACT

The design, construction and implementation of a computer controlled radio frequency (RF) noise measurement and recording system in the 30.45 MHz and 150.75 MHz range and the interfacing of this system to a digital satellite link is presented. Earthquake prediction by the use of various precursors and the specific use of electromagnetic emissions in the RF range as a precursor to future earthquake activity is described.

Accession For	
NTIS CRA&I	<input checked="" type="checkbox"/>
DTIC TAB	<input type="checkbox"/>
Unannounced	<input type="checkbox"/>
Justification	
By	
Distribution/	
Availability Codes	
Dist	Availability and/or Special
A-1	



TABLE OF CONTENTS

I.	INTRODUCTION	11
	A. THE NEED FOR EARTHQUAKE PREDICTION RESEARCH	11
	B. RESEARCH PROJECT BACKGROUND	13
	C. FOCUS OF STUDY	15
II.	BACKGROUND	18
	A. STRUCTURES OF EARTHQUAKE PREDICTION	18
	1. Statistical Prediction	18
	2. Tectonic Prediction	20
	3. Physical Prediction	20
	4. Quick Alarm	21
	B. RADIO FREQUENCY EMISSIONS	22
III.	THE SATELLITE LINK	25
	A. GENERAL BACKGROUND	25
	B. THE GOES DATA COLLECTION SYSTEM	27
	1. Data Collection Platform Radio Sets .31	
	a. Self-Timed	31
	b. Self-Timed and Random Reporting .32	
	c. Random Reporting	32
	d. Interrogated	32
	e. International Self-Timed	33

	2. East and West Spacecraft Transponders33
	3. Command and Data Acquisition Station.	36
	4. Central Data and Dissemination Facility36
	C. DIGITAL SATELLITE LINK INTERFACE	38
IV.	DESCRIPTION OF RESEARCH39
	A. DESIGN OVERVIEW39
	B. SYSTEM HARDWARE DESIGN AND OPERATION .	.47
	1. Receivers47
	2. Interface Amplifiers51
	3. Analog To Digital Converter56
	4. Computer56
	5. Disk Drives62
	6. Power Supply System64
	7. Interface Connections66
	C. SYSTEM SOFTWARE DESIGN AND OPERATION .	.67
	1. Digitize.com67
	2. Datacopy.com72
	3. Micro to Mainframe File Transfer .	.74
	4. Convert Fortran75
	5. Eqrfgraf Fortran77
	D. SYSTEM PERFORMANCE77

V.	RECOMMENDATIONS AND CONCLUSIONS92
A.	RECOMMENDATIONS92
B.	CONCLUSIONS93
APPENDIX A:	DIGITIZE.COM COMPUTER PROGRAM95
APPENDIX B:	DATACOPY.COM COMPUTER PROGRAM98
APPENDIX C:	CONVERT FORTRAN COMPUTER PROGRAM99
APPENDIX D:	EQRFGRAF FORTRAN COMPUTER PROGRAM	101
LIST OF REFERENCES	103
INITIAL DISTRIBUTION LIST	105

LIST OF TABLES

I	MFC PORT 5 (P5) PIN ASSIGNMENTS (A/D CONVERTER INPUTS)58
II	OEM188 PORT 3 (P3) PIN ASSIGNMENTS (TERMINAL CONNECTOR)61
III	OEM188 CONFIGURATION SWITCH SETTINGS61
IV	AUXILIARY RS-232 SERIAL PORT 4 (P4) PIN ASSIGNMENTS63
V	SYSTEM PERFORMANCE LEVELS79

LIST OF FIGURES

1.1	Collected Data for November/December 198516
2.1	Stages of Earthquake Prediction19
2.2	Collected Data for 25 to 27 January 198624
3.1	G.O.E.S. Satellite System Area of Coverage . .	.26
3.2	G.O.E.S. Data Collection System30
3.3	East and West Spacecraft Channel Numbering . .	.35
3.4	Typical Data Collection Platform Message37
4.1	Median Man-Made Radio Noise Power Expectations	.40
4.2	Site Location41
4.3	Site Location42
4.4	Design Overview Diagram44
4.5	Channel Assignments45
4.6	System Hardware Block Diagram48
4.7	38.45 MHz VHF Converter49
4.8	150.75 MHz VHF Converter50
4.9	IF/Audio Assembly52
4.10	Interface Amplifier53
4.11	Graph of Receiver Input vs A/D Converter Input	.55
4.12	Schematic Diagram of Multifunction Board57
4.13	Schematic Diagram of OEM188 Computer60
4.14	Power Supply System65
4.15	Data Processing Flow Chart68
4.16	Sample Acquired Data File80

4.17	Sample File FT08F001 File81
4.18	Channel 01 Signal Levels82
4.19	Channel 02 Signal Levels83
4.20	Channel 03 Signal Levels84
4.21	Channel 04 Signal Levels85
4.22	Channel 05 Signal Levels86
4.23	Channel 06 Signal Levels87
4.24	Channel 07 Signal Levels88
4.25	Channel 08 Signal Levels89
4.26	Channel 09 Signal Levels90
4.27	Channel 10 Signal Levels91

ACKNOWLEDGEMENTS

The completion of this thesis can be attributed to a countless number of people providing me with their inspiration, direction, knowledge and support. I specifically wish to thank Dr. Richard W. Adler and Dr. Stephen Jauregui, Jr., for providing their technical expertise and guidance. I am deeply obliged to Electronics Technician First Class John Babka for the significant contributions he has made to the design and construction of the system's electronic equipment. His dedication and efforts to the research in this field has been a driving force in three thesis projects to date. Last, but certainly not least, I wish to thank my wife [REDACTED] for her patience and inspiration.

I. INTRODUCTION

A. THE NEED FOR EARTHQUAKE PREDICTION RESEARCH

Intensive academic and social attention has been drawn to earthquake prediction, especially in countries like Japan, the United States, China and the Soviet Union which have all suffered from very destructive earthquakes on numerous occasions. Investigation into the realm of earthquake prediction in these countries has brought out clues pointing to the fact that the prediction of some earthquakes, if not all of them, will be attainable in the foreseeable future. Of course, all of the permanent measures that are used to reduce earthquake hazards, such as better engineering design, improved land use planning, and upgraded building codes and construction practices will continue to be needed even though earthquake predictions may eventually become completely reliable. The benefits to society from accurate earthquake prediction will be substantial in the savings of lives and property.

It has been estimated that the knowledge of an impending great earthquake a year or more in advance would result in a large reduction in losses. The savings would result from measures taken to strengthen buildings and their contents, reduce fire hazards, increase dam

safety, enhance nuclear power plant safety and so on. For shorter term predictions such as a week in advance, substantial savings of lives would result from temporary measures such as the evacuation of dangerous buildings and the mobilization of emergency forces. [Ref. 1:pp. 35-45]

It is known in many instances that the earthquake itself will cause less damage and casualty than the events which occur following the actual geophysical phenomena. Fires and explosions resulting from ruptured gas lines, gasoline storage tanks, power lines and transformers will contribute to the severe loss of life and property. If the utilities such as gas and electricity were to be equipped with sensing devices which would automatically interrupt services when precursory information was acquired concerning a potential earthquake, great devastation could be spared. If the ability to predict an earthquake could be soundly established, a more calculated reaction to the event could be made. Evacuation of endangered areas, or even the planned demolition in advance of structures deemed unsafe in the event of a major temblor could be accomplished. Unfortunately, the ability to accurately and reliably predict the location and intensity of a forthcoming earthquake is unavailable at the present time.

Great excitement currently exists among seismologists over major achievements in the effort to predict earthquakes. Various physical phenomena precursory to earthquakes have been reported. Measurable physical precursors are now coming under intense scientific scrutiny and many appear to be valid. Several scientific predictions have already been successful, although they were for smaller scale earthquakes [Ref. 2]. Few seismologists now doubt that physical precursors to earthquakes do in fact exist. However, the ability to be sufficiently consistent and uniform enough to permit development of a routine and reliable prediction system does not exist.

B. RESEARCH PROJECT BACKGROUND

This thesis advances the previous research into the evidence of radio frequency (RF) emissions as a precursor to earthquake activity. Citizen band and amateur radio operators in the Hollister, California area have reported an "increase in the background noise level preceding earthquake activity" at 27 MHz and at the six and two meter bands. The increase in noise was on the order of 10 dB and preceded a quake by 12 to 24 hours. At one hour to fifteen minutes prior to an actual earthquake, noise levels returned to normal [Ref. 3:p. 11]. The appearance of a phenomena known as earthquake lights

[Ref. 4] and the reception of 18 MHz radio noise [Ref. 5] are further examples of the potential link between RF energy and the occurrence of earthquakes. Further presentation of measured precursory events and the associated theories to explain them are presented later in this thesis.

The design of a freestanding VHF noise measurement and recording system to predict the intensity and location of earthquakes from electromagnetic radiation at an active geophysical location along the San Andreas Rift Zone (fault) was initiated in 1984 [Ref. 6] by a joint project of the U.S. Geological Survey Office and the Naval Postgraduate School. The following year the proposed design of a space based sensor to predict the intensity and location of earthquakes from electromagnetic emissions was completed and the initial installation of the noise measurement and recording system was made [Ref. 3]. It is at this point that the endeavors of this thesis begin.

The data acquired from the VHF noise measurement system was observed for background noise level variations. Seismological data acquired from the Geological Survey Office was compared to the data obtained on the chart recorder paper. In order to accurately correlate the data it was necessary to manually measure the magnitude of the VHF signal at

predetermined time intervals off of the chart recordings, then enter these readings into a computer for future graphical display. This process of digitizing the data every two weeks for the recordings of ten separate channels of information stored on very lengthy rolls of chart recorder paper is extremely time consuming. An example of some of the first data retrieved from the chart paper is shown in Figure 1.1. Each of the plots represent two weeks of data for one specific channel. Approximately six man hours were used to obtain these graphs.

A solution to reducing the amount of time required to analyze the collected data, as well as obtaining a means of transmitting this data over a digital satellite link was being sought after by the U.S. Geological Survey Office. A monitoring system in the Parkfield, California area relying on the phone system for the transmission of data had lost vital information during an actual earthquake.

C. FOCUS OF STUDY

In order to fulfill the need for an accurate and reliable radio frequency noise measurement and recording system for detection on the 30 MHz and 150 MHz bands which provides the means for rapid data acquisition and analysis, the design of a computer controlled monitoring

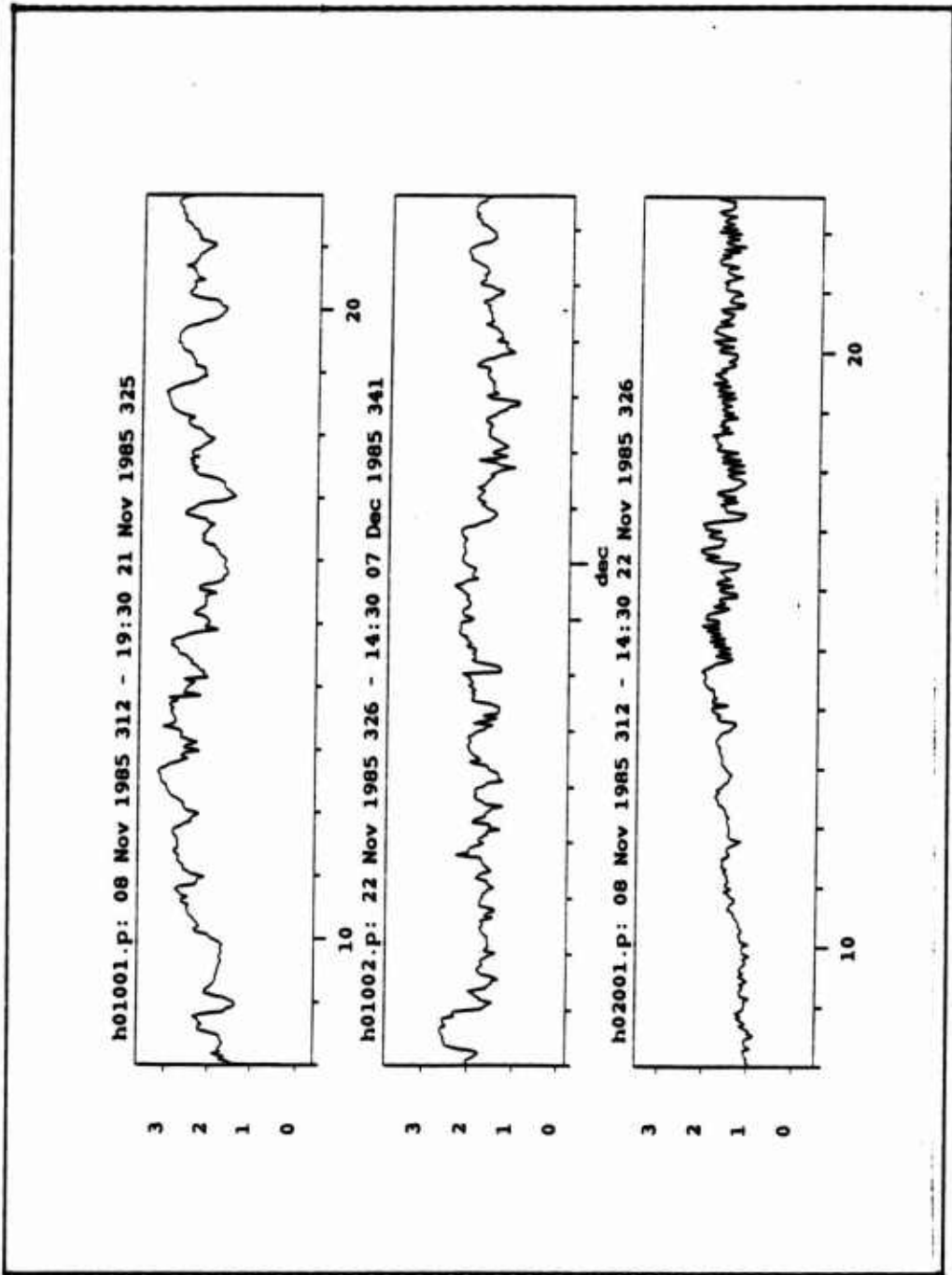

Figure 1.1 Collected Data for November/December 1985

system is presented. Initially the data is stored on magnetic disk to allow for a series of software routines to graphically display the data. In addition, the need for a survivable remote sensing capability is fulfilled by the design of digital satellite link interface. The data may be sent from the constructed computer monitoring system to a Data Collection Platform Radio Set (D.C.P.R.S.) for transmission via the Geostationary Operational Environmental Satellite (G.O.E.S.) transponder to the Command and Data Acquisition Station in Wallops Station, Virginia. The establishment of a correlation between increased background RF noise to future earthquake fault activity may be accomplished as a result of the improved data analysis capability.

II. BACKGROUND

A. STRUCTURES OF EARTHQUAKE PREDICTION

A successful prediction must include the correct assessment of three elementary factors, namely the time, place and size of the predicted earthquake. In order to approach this goal, a prediction should develop systematically through the stages shown in Figure 2.1 [Ref. 7:p. 195]. The size of the various rectangles shown in the diagram represent the relative degrees of uncertainty in the different types of prediction. A discussion of the various realms of the prediction process follows.

1. Statistical Prediction

The first stage of earthquake prediction called statistical prediction, is based on the assumption that earthquakes occur in a sequence with a statistical characteristic which does not change with time. If the sequence of the earthquakes has either a predominant period or a probable correlation to a known external factor, then the future activity may be predicted statistically. However, the prediction will involve a considerable degree of uncertainty. This type of broad scale prediction is satisfactory for preliminary work such as in long-term planning of optimum monitoring systems and disaster prevention work.[Ref. 7:p. 194]

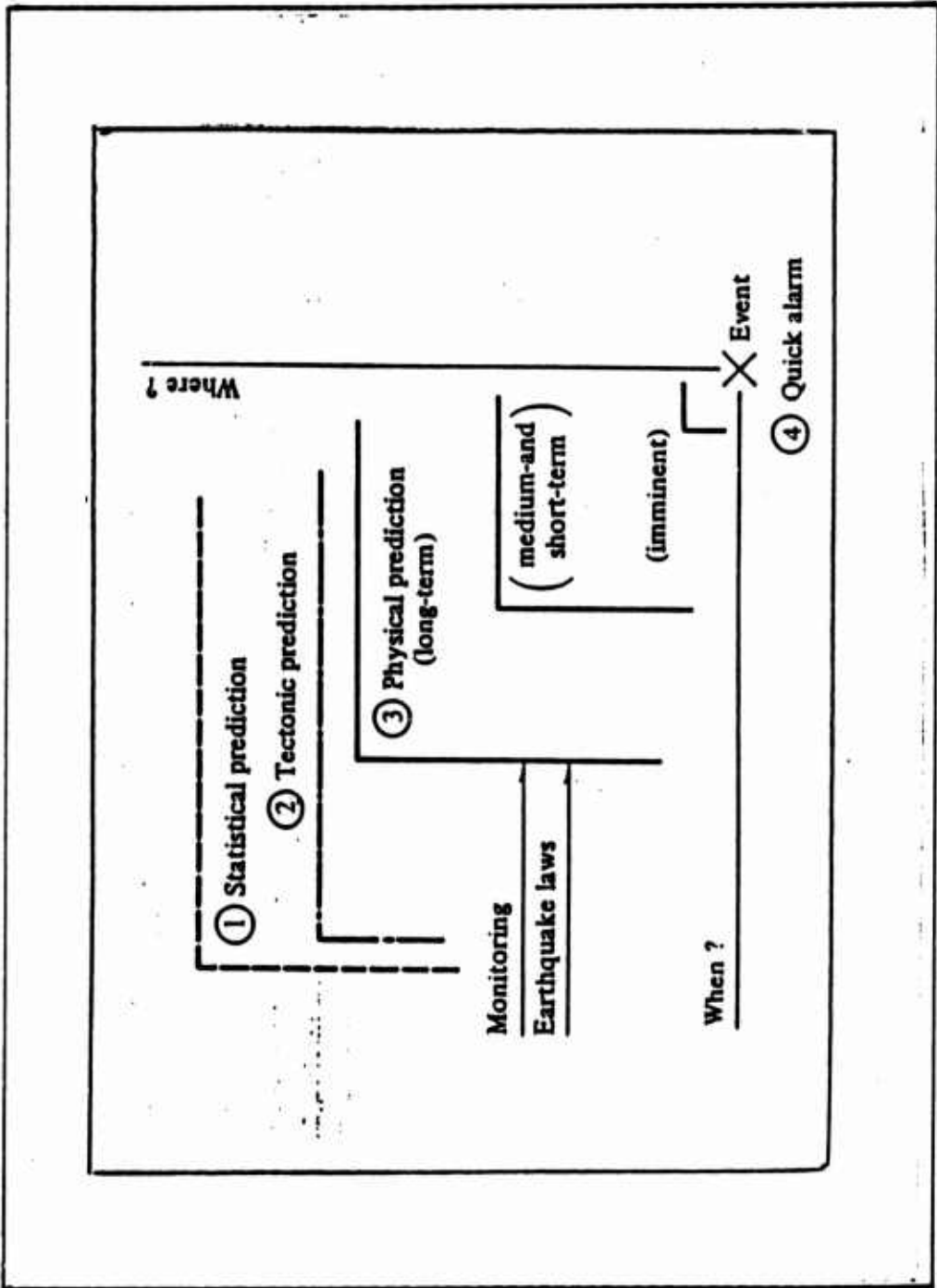

Figure 2.1 Stages of Earthquake Prediction

2. Tectonic Prediction

This type of prediction is primarily concerned with the magnitude, type and other tectonic parameters of an earthquake that is likely to occur in a given locality [Ref. 8:p. 1082]. The accumulation law of seismotectonic movement relates the amount of accumulated strain and stress across a fault to the potential for the occurrence of an earthquake. This type of prediction will provide a mean lapse time for the seismic cycle, but precise time information is not available [Ref. 7:p. 195].

3. Physical Prediction

Physical prediction attempts to precisely determine the three critical factors of time, place and size by the recognition of meaningful seismic precursors to major earthquakes. It is an essential requirement that a sufficient understanding of the physical laws of earthquakes be available and precise monitoring of the area in and around an earthquake be made at the proper time. Preseismic anomalies have been noticed in the study of many other geophysical phenomena [Ref. 9]. In addition to the extraordinary behavior of fish and animals, there is an extensive set of precursors experienced at various times and in various regions of the world of the following types:

- land deformation
- tilt and strain
- foreshock
- microseismicity
- source mechanism
- fault creep anomaly
- seismic wave velocity
- geomagnetic field
- telluric (earth) currents
- electromagnetic emissions
- resistivity of the earth
- radon content
- underground water
- oil flow

An in depth discussion of the shock wave theory of radio emissions from earthquake fault lines is presented, as this is the focal point of the thesis. The design and construction of the computer controlled VHF radio noise measurement and recording system is based on the concept of using electromagnetic emissions as a precursor to future earthquake activity.

4. Quick Alarm

In strictest terms this last stage is not really prediction, but actually a method of practical disaster reduction. This stage relies upon a fully-automated monitoring system which is linked to critical public

and/or industrial facilities so that they may be controlled promptly in an emergency. . If the system detects and recognizes an imminent seismic event, the critical facilities such as the utilities of gas and electricity could be secured before the main seismic disturbance strikes.[Ref. 7:p. 196]

Practical earthquake prediction may eventually be accomplished by analyzing the accumulated predictions of each of the four stages. The successful use of these predictions in an orchestrated effort to accurately and reliably predict earthquakes is in the foreseeable future.

B. RADIO FREQUENCY EMISSIONS

This thesis investigates the potential of using electromagnetic emissions in the radio frequency range as a precursor to earthquake activity. Radio frequency emissions from active earthquake fault lines have been reported by radio amateurs in the HF and VHF band of frequencies. The emissions are theorized to be caused by the increasing mechanical pressure at the fault causing shear stresses that convert the insulating rock into a conductor (or semi-conductor) by reducing the energy gap between the valence and conduction bands. During the stress increase, microfractures cause shock waves that accelerate the electrons in the conducting bands to

radiate both acoustic and electromagnetic energy. If the mechanical forces increase to the yield point, the rock fails in brittle fracture and causes a sudden decrease in the shear forces resulting in electron accelerations that produce either large increases in radio noise, or in the phenomena known as clear weather lightning.[Ref. 10: p. 1]

The initial noise measurement and recording system using chart recorders to amass data, was placed into operation in November of 1985 [Ref. 3:p. 67]. The data on all ten channels was being collected and the chart recorder paper being changed every two weeks as designed. On January 26, 1986 a mild earthquake occurred in the general vicinity of the Hollister site. Less than 1 km away from the detection system a local winery had a large cask of wine fall from its stand as a result. Analysis of the data obtained from the chart recordings for the time frame surrounding the incident appears to support the observations of the amateur and citizen band radio operators. An increase in the general background noise floor prior to the quake occurred, as well as a sharp decrease in the level just prior to the quake. Figure 2.2 illustrates the radio frequency noise levels for the January 25 to 27, 1986 period on both the 38 MHz and 150 MHz frequencies.

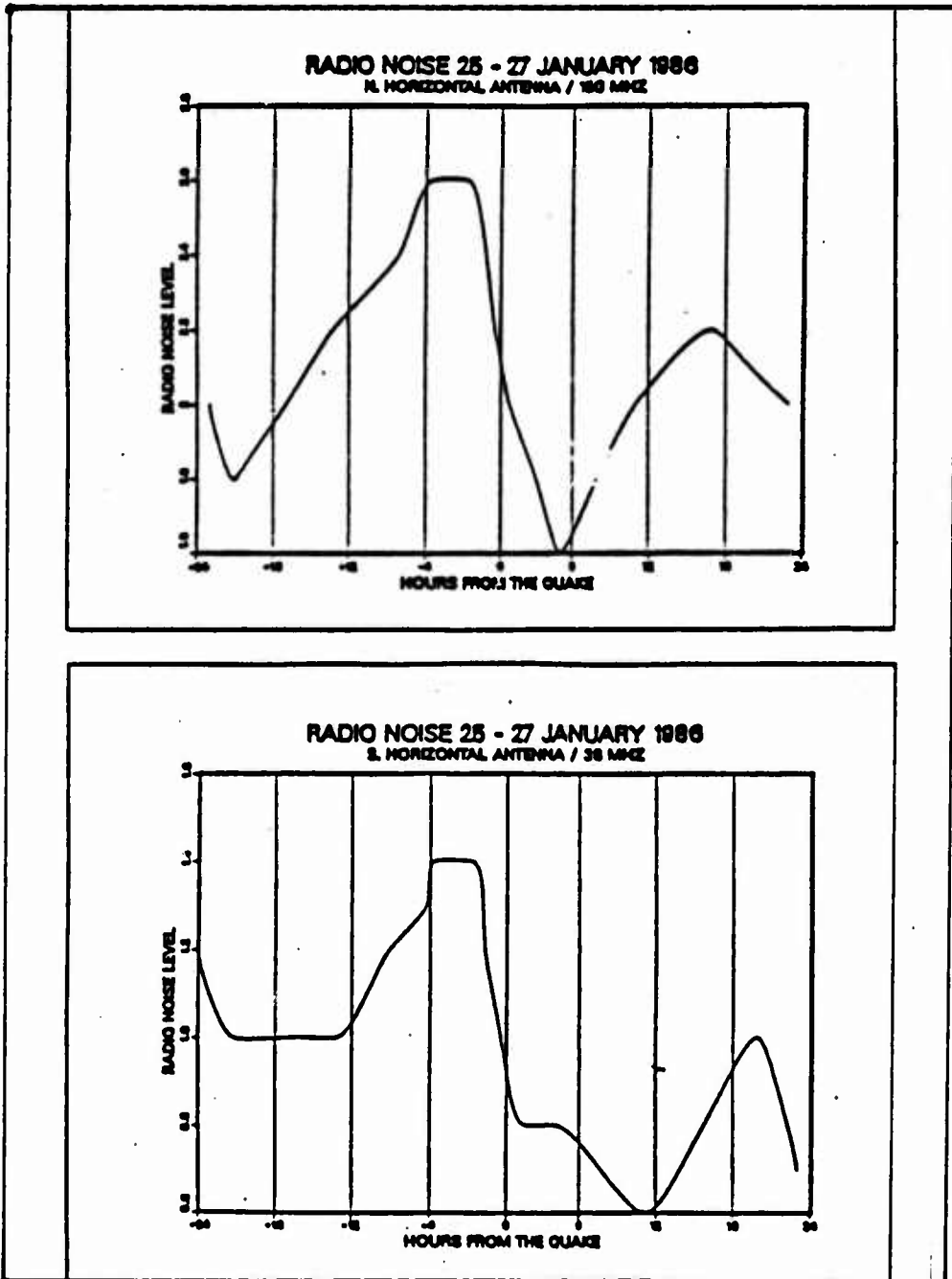

Figure 2.2 Collected Data for 25 to 27 January 1986

III. THE SATELLITE LINK

A. GENERAL BACKGROUND

To fulfill the requirement that the currently designed computer controlled VHF noise measurement and recording system be capable of having the collected data transmitted over a satellite link, the U.S. Geological Survey Office proposed the use of a commercial transmitter which utilizes the Geostationary Operational Environmental Satellite Data Collection System. Commercial UHF satellite transmitters are currently being used to provide a remote sensing capability for selected environmental sensors and are compatible with this system. [Ref. 11] and [Ref. 12] provide the background information for interfacing the computer controlled VHF noise measurement and recording system to the established data collection satellite link. The system becomes a remote sensing device, providing ready access to the data without traveling to the site to retrieve the data stored on the magnetic disk. Specifics of the actual hardware interfacing of the designed system to the satellite link are provided later in the thesis. To provide a workable understanding of the system so future users are familiar with its overall operation, a basic overview of the satellite link is presented [Ref. 11:pp. 2-17] and [Ref. 12:pp. 2-9].

There are currently two functioning Geostationary Operational Environmental Satellites (G.O.E.S.) that are part of a system of earth and space environmental sensors which provide an almost continuous observational information flow to the ground based user stations. The GOES system is operated and controlled by the National Environmental Satellite Data and Information Service (NESDIS). The organization was formerly called the National Earth Satellite Service (NESS). NESDIS is a suborganization of the National Oceanic and Atmospheric Administration (NOAA) which is controlled by the U.S. Department of Commerce. The GOES system itself was a result of the combined efforts of NESDIS and the National Aeronautics and Space Administration (NASA) based on the experiments with the NASA advanced technology satellites.

The GOES system consists of several subsystems, one of which is the Data Collection System (DCS). The Data Collection System uses the GOES spacecraft for the relay of data from remotely located sites on, or nearly on the surface of the earth. Of course these remote sites must be in radio view of the satellite. There are many other uses for the GOES satellite, but the discussion of these is beyond the scope of this thesis.

There are two GOES satellites located in geosynchronous orbits over the equator at 75 degrees West and 135 degrees West longitudes. The radio view of the

two spacecraft is from approximately 0 degrees westward to 165 degrees East longitude. There is a limitation of the coverage to approximately 77 degrees North and South latitudes. See Figure 3.1. In case of a failure of either the "East " or "West" satellites just mentioned, there is a third geostationary satellite in a geosynchronous orbit halfway between them at 107 degrees West longitude. This craft is also used to prevent data loss as a result of either satellite being temporarily out of commission as a result of an eclipse period.

B. THE GOES DATA COLLECTION SYSTEM

The GOES Data Collection System (DCS) is a satellite based system for the collection of a large variety of environmental data obtained from almost any point in the Western Hemisphere. It is a data relay network composed of literally thousands of individual data gathering devices known as Data Collection Platforms that each transmit the data they have acquired to one of the GOES satellites. The signal is then relayed from the satellite to the Command and Data Acquisition (CDA) Ground Station located in Wallops Station, Virginia.

The transponders carried onboard the GOES spacecrafts relay the UHF transmissions from the Data Collection Platforms (ranging from 401.7 MHz up to 402.1 MHz) via S-band transmission to the ground receiving station. Conversely, S-band transmissions from the

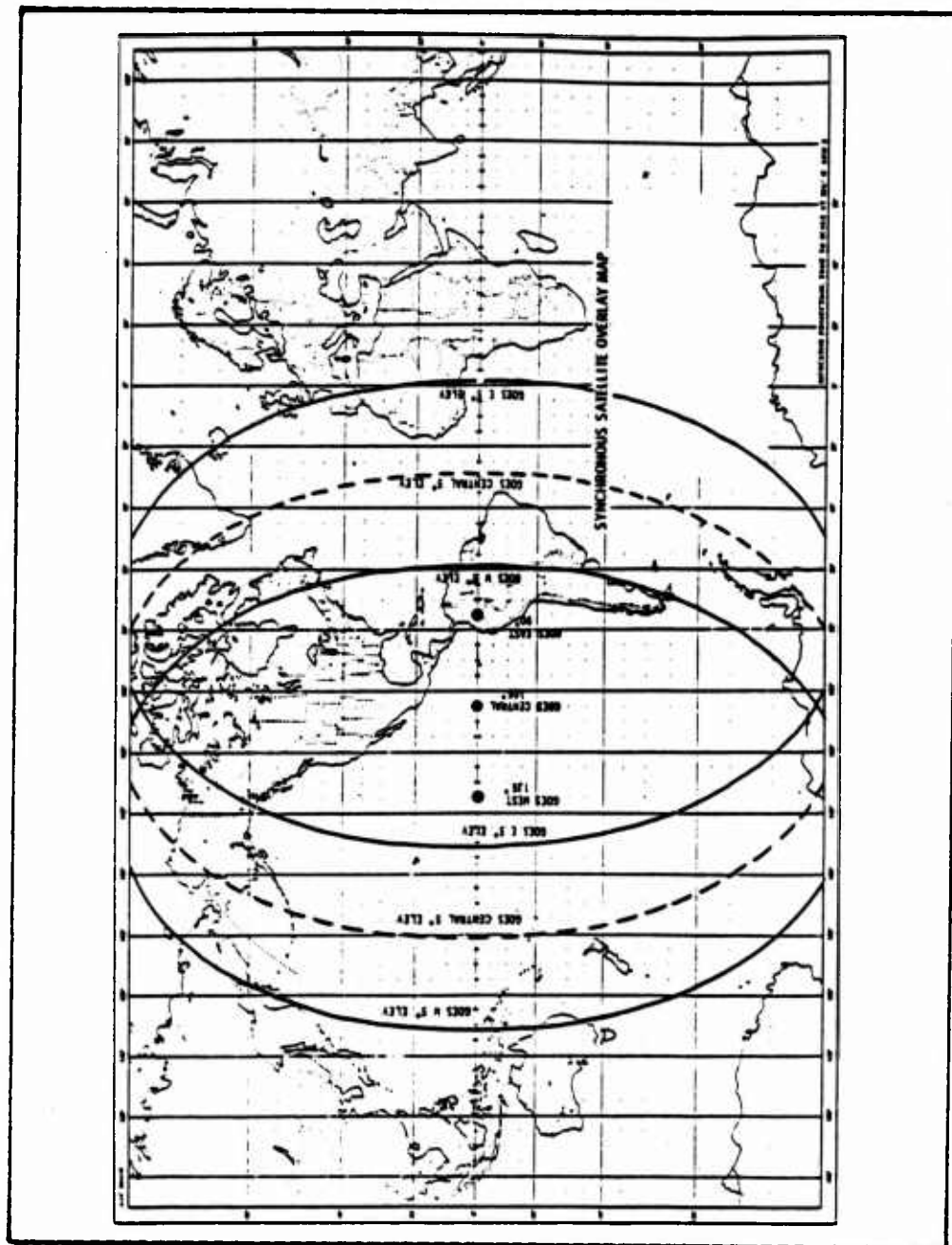

Figure 3.1 G.O.E.S. Satellite System Area of Coverage

NESDIS ground station can be relayed through the spacecraft transponder and converted into a UHF transmission for dissemination to properly equipped receivers in radio view of the satellite.

The satellite transponders are capable of supporting up to 233 reply channels. There are 200 channels reserved for use by regional and domestic channels ranging from 401.7 MHz up to 402.0 MHz, each with a 1.5 KHz channel separation. The other 33 channels are for international use in the 402.0 MHz to 402.1 MHz range. Each has a 3.0 KHz channel separation. The ground system is limited to supporting 80 channels and 5000 Data Collection Platforms.

There are four functional subsystems of the GOES Data Collection System. They are as follows:

- Deployed Data Collection Platform Radio Sets
- East and West Spacecraft Transponders
- Command and Data Acquisition Station
- Central Data and Dissemination Facility

A brief discussion of each of these is necessary for a basic understanding of how the GOES Data Collection System operates and subsequently how the designed VHF noise measurement and recording system can interface with the satellite link to achieve the remote sensing capability. Figure 3.2 shows a block diagram of the G.O.E.S. Data Collection System.

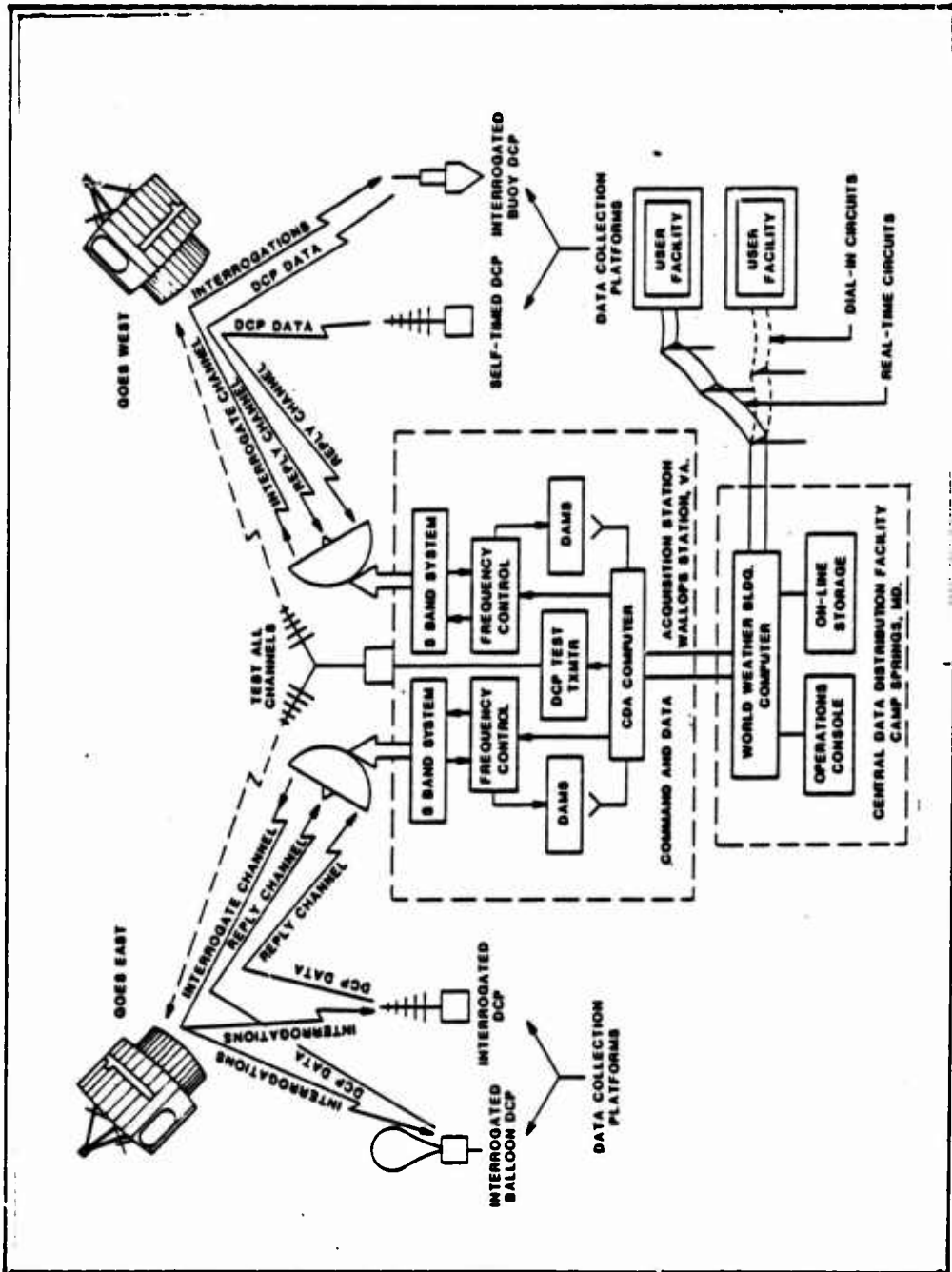

Figure 3.2 G.O.E.S. Data Collection System

1. Data Collection Platform Radio Sets

There are five different types of Data Collection Platform Radio Sets (DCPRS) which permit various modes of system operation. They are as follows:

- Self-Timed
- Self-Timed and Random Reporting
- Random Reporting
- Interrogated
- International Self-Timed

A description of each type follows.

a. Self-Timed

Self-Timed DCPRS contain only a transmitter and a timing source which is preprogrammed by the user to report during a specific hour at a specific minute and at a specific rate over a 24 hour period. The preprogrammed reporting time and rate of the DCPRS is not at all related to the cycle of the sensor attached to the platform. The sensor cycle refers to the time interval or frequency of when the environmental sensor attached directly to the DCPRS reads its specific data. The data is then placed into a memory buffer in the DCPRS for transmission at the preprogrammed time. For example, a DCPRS may have data transferred to it from an environmental sensor every five minutes, but this data would be stored temporarily and then transmitted through

the GOES Data Collection System only once every three hours.

b. Self-Timed and Random Reporting

Self-Timed and Random Reporting DCPRS have the same characteristics as the previously mentioned type, however, it also has the ability to transmit over a secondary channel when environmental conditions require more frequent reporting than offered under self-timed operation. In this DCPRS the normal self-timed mode can be used under most circumstances, but if the need for more immediate data is required, the DCPRS can be automatically placed into the random reporting mode.

c. Random Reporting

The Random Reporting DCPRS contains a transmitter which will broadcast at a random time. This is controlled by environmental conditions being monitored by the sensor having reached a preassigned threshold. However, the Random Reporting DCPRS are also preassigned to report at least three times a day in order to assure that the DCPRS and the sensor are functioning properly.

d. Interrogated

Unlike the other types of DCPRS, the Interrogated DCPRS contain both a transmitter and a receiver. The onboard receiver is preset to either the East or West spacecraft DCPRS interrogation link frequency which enables it to detect its own unique

identification or address when transmitted from the Command and Data Acquisition (CDA) Station at Wallops Station, Virginia. If a DCPRS recognizes its own special identification or callsign, it is programmed to transmit all of the data it has stored since the previous interrogation. The scheduling of the Interrogated DCPRS is very similar to the Self-Timed DCPRS, except that the schedule is stored at the Command and Data Acquisition Station instead of within the DCPRS themselves. The interrogation of the DCPRS may occur at intervals as small as 5 minutes or as large as once every 24 hours. In addition, some of the interrogated DCPRS have a secondary alert channel which will send an alert signal to the CDA telling it to interrogate because a preassigned threshold has been reached.

e. International Self-Timed

The International Self-Timed is identical to the domestic Self-Timed except for the range over which the UHF transmitters may transmit.

2. East and West Spacecraft Transponders

The next subsystem of the GOES Data Collection System to be discussed is the set of transponders aboard the East and West spacecraft. The GOES "East" spacecraft is located at 75 degrees West and the GOES "West" spacecraft at 135 degrees West. Each of the craft are capable of handling the 233 channels allocated for the

system (200 domestic and 33 international). However, extra channel bandwidth is provided for all of the domestic channels by assigning the odd numbered channels to the East spacecraft transponder and the even channels to the West spacecraft transponder. As a result, a 3.0 KHz guard bandwidth is achieved between adjacent channels. A further organization of the channels is made by the assignment of certain blocks of channels on each spacecraft to specific types of DCPRS. See Figure 3.3 for a comparison of the odd/even channel assignments. The international channels are assigned to both the East and the West spacecraft at all times.

The Command and Data Acquisition Station sends out command and interrogate signals to the appropriate spacecraft transponder at an S-band frequency that is transformed into a UHF signal. Each spacecraft transponder sends out a different UHF frequency to the Data Collection Platform Radio Sets. The assigned frequency for the East is 468.8375 MHz and the assigned West frequency is 468.825 MHz. The response signals sent up from the Interrogated DCPRS and the self-transmitted signals from the Self-Timed and the Random Reporting DCPRS are sent up at UHF frequencies. The signals are then translated by the satellite transponders to S-band and then retransmitted to the Command and Data Acquisition Station.

**EAST SPACECRAFT
ODD NUMBERED CHANNELS**

1-39	41-69	71-93	95-111	113-145	147-165	167-199
Self-timed	S/T Direct Readout	Self-timed	Interrogate	Random Reporting	Spare	LANNION-Relay

**WEST SPACECRAFT
EVEN NUMBERED CHANNELS**

2-40	42-70	72-94	96-110	112-144	146-164	166-198
Self-timed	Self-timed Direct Readout	Self-timed	Interrogate	Random Reporting	Spare	Spare

Figure 3.3 East and West Spacecraft Channel Numbering

3. Command and Data Acquisition Station (CDA)

The messages are received from either one of the spacecraft via their S-band transmissions into the CDA. The received Data Collection Platform Radio Set messages are then routed to the Data Acquisition and Monitoring Subsystem (DAMS) units which will demodulate the data and perform signal quality measurements. A typical DCP message containing the DAMS quality information is shown in Figure 3.4. The data information is then transferred from the CDA to the Central Data and Dissemination Facility over high speed dedicated circuits for further dissemination. As mentioned previously, the CDA computer contains the schedule files for the Self-Timed and Interrogated types of DCPRS.

4. Central Data and Dissemination Facility

The Central Data and Dissemination Facility (CDDF) is located in the World Weather Building at Camp Springs, Maryland. There are two identical computers there. One of them is on-line at all times, while the other is used for statistical analysis. The incoming messages from the Command and Data Acquisition Station are then routed to the users of the DCPRS via landline along with any pertinent error information detected during the processing of the message.

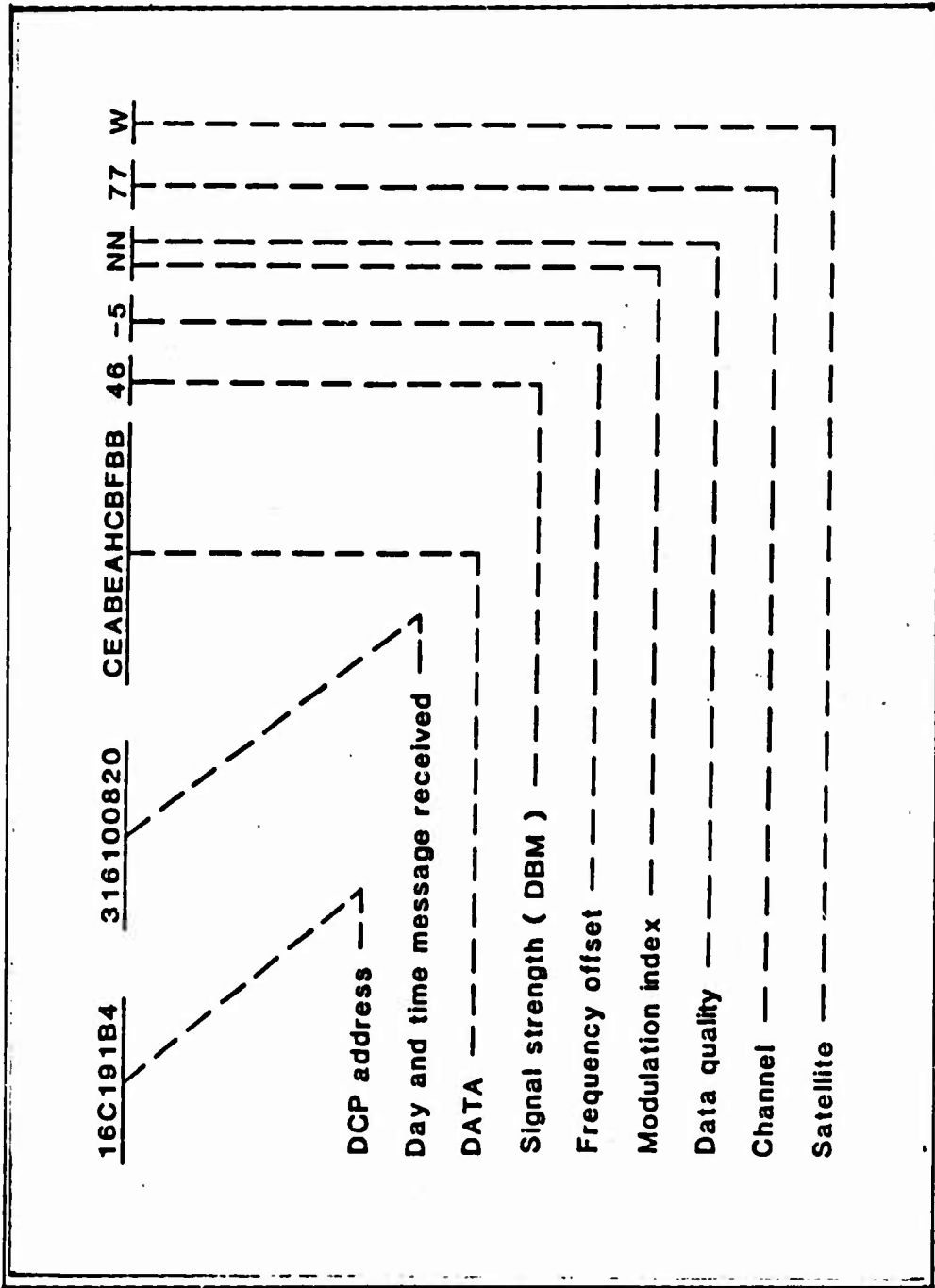

Figure 3.4 Typical Data Collection Platform Message

C. DIGITAL SATELLITE LINK INTERFACE

The designed computer controlled VHF noise measurement and recording system is capable of sending binary data out of an RS232 port in a serial format with a number of software programmable variations of the data bit stream. A detailed analysis of how the system can forward the acquired data to the buffer in a Data Collection Platform Radio Set will be presented later in this thesis.

IV. DESCRIPTION OF RESEARCH

A. DESIGN OVERVIEW

The design, construction and implementation of the computer controlled radio frequency (RF) noise measurement and recording system was accomplished by advancing the previous research into precursory electromagnetic activity associated with earthquakes [Ref. 3] and [Ref. 6]. The location of the installed monitoring system is three miles east of San Juan Batista, California and seven miles south of Hollister. This site is located within the Hollister Hills State Vehicular Recreation Area (upper ranch), directly south of the MX track. The site was chosen in previous research projects because it is historically an active location. In addition, the location is remote enough to be considered a rural area with respect to man-made radio noise. Figure 4.1 refers. The exact location is one thousand feet from the San Andreas fault at 121 degrees and 23.5 minutes West longitude and 36 degrees 45.5 minutes North latitude. Figures 4.2 and 4.3 provide a detailed means of locating the site.

The completion of the thesis involved the coordination of efforts in both hardware and software design to accomplish the established goals of obtaining

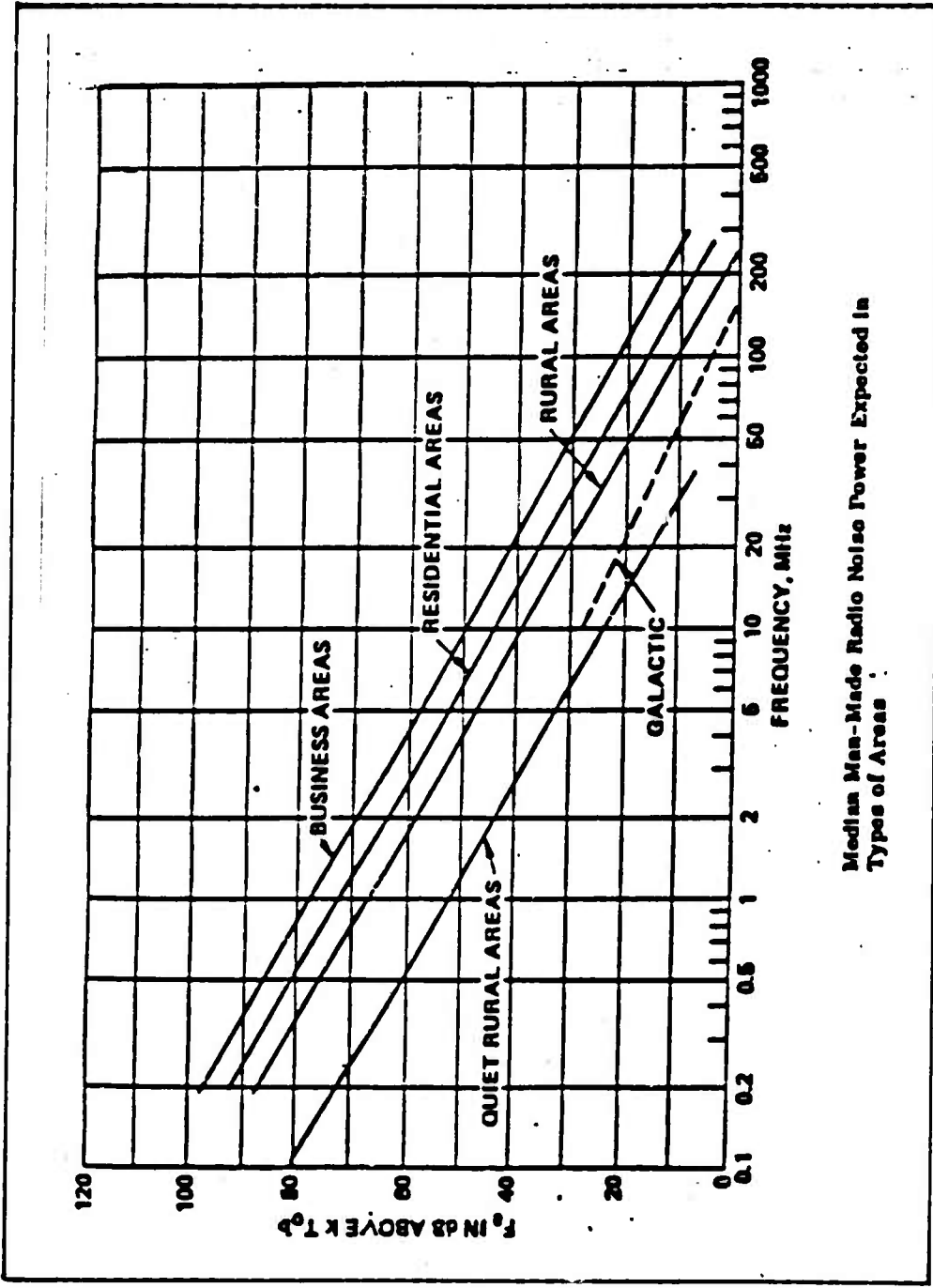

Figure 4.1 Median Man-Made Radio Noise Power Expectations

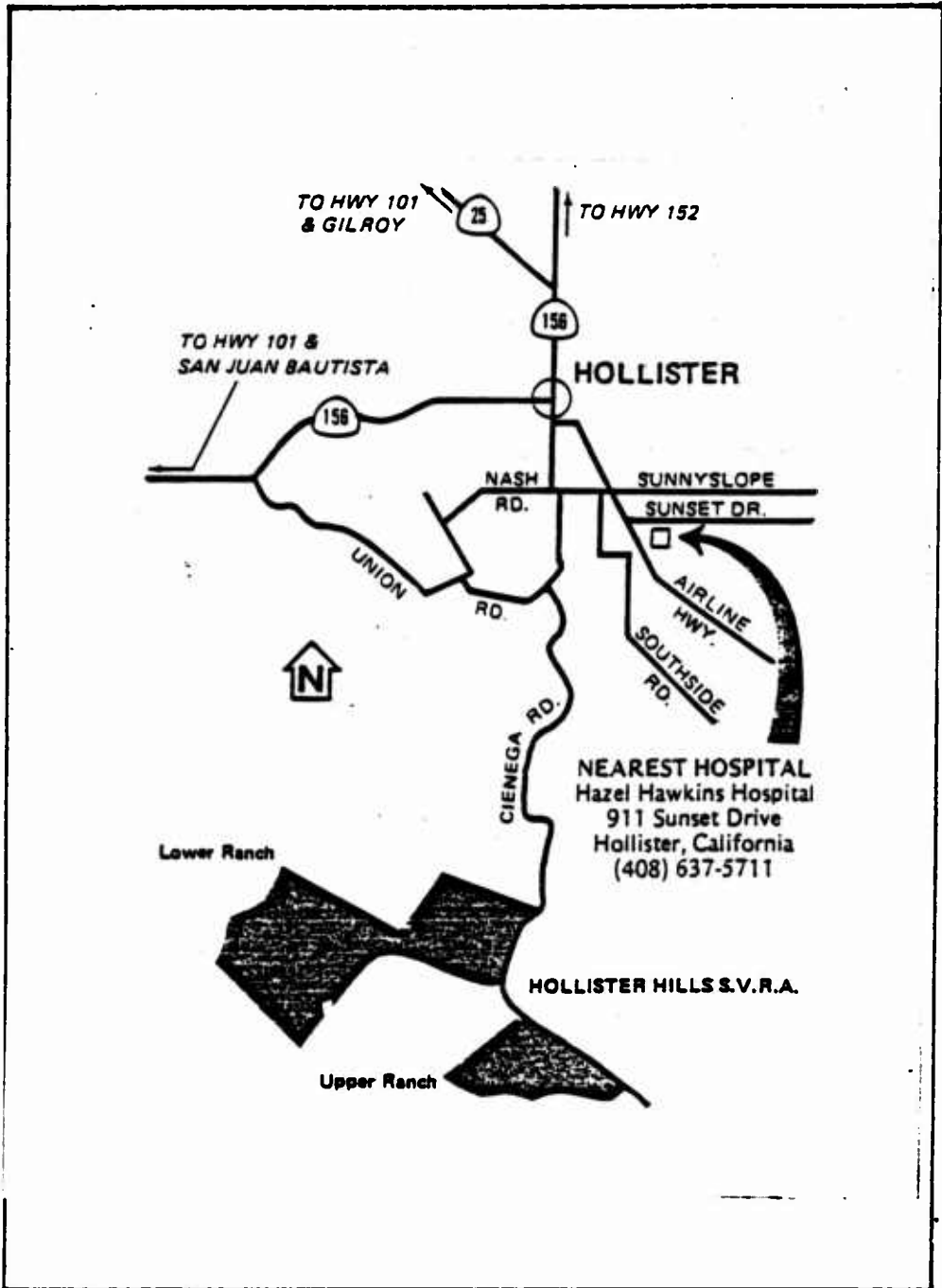

Figure 4.2 Site Location

a data recording and analysis system, as well as the digital satellite link. Figure 4.4 provides a block diagram of the hardware system and a flow chart of the software used on the Naval Postgraduate School IBM 3033 computer to provide graphical display of the data stored on 5.25 inch magnetic disks. The two frequencies being monitored (38.45 MHz and 150.75 MHz) have a bandwidth of 50 KHz. They have been established as receive only channels to allow the Naval Postgraduate School to investigate the short and long term variations of background noise (noise floor). The Army Frequency Coordinator for the Western United States will continue these assignments on a yearly basis.

The antenna structure consists of two twenty foot towers and ten antennas. Each tower has five antennas mounted on it. Eight yagi antenna receive the horizontally and vertically polarized signals of the two frequency ranges. Omni antenna for each of the frequencies are vertically mounted. See Figure 4.5 for a list of the specific channel assignments. The signals received by each of the antenna are individually cabled to ten modular amplitude modulation (AM) receivers.

Once the receiver has processed a signal, a voltage level corresponding to the strength of this incoming signal is obtained from the "S" meter output. This output voltage level is sent to an interface amplifier

CHANNEL ASSIGNMENTS			
<u>CHANNEL</u>	<u>FREQUENCY (MHZ)</u>	<u>POLARIZATION</u>	<u>DIRECTION</u>
1	150.75	VERTICAL	NORTHWEST
2	150.75	VERTICAL	SOUTHEAST
3	150.75	OMNI	-----
4	150.75	VERTICAL	NORTHWEST
5	150.75	HORIZONTAL	SOUTHEAST
6	38.45	VERTICAL	SOUTHEAST
7	38.45	HORIZONTAL	SOUTHEAST
8	38.45	VERTICAL	NORTHWEST
9	38.45	HORIZONTAL	NORTHWEST
10	38.45	OMNI	-----

Figure 4.5 Channel Assignments

where it is amplified to a range of zero to five volts, corresponding to the minimum and maximum received signals of interest, respectively. The zero to five volt range signal is then quantized by an 8-bit analog to digital converter. The data is stored in an ASCII format on magnetic disk. The data is also sent out RS232 ports to a buffer on a Self-Timed Data Collection Platform Radio Set (D.C.P.R.S.) for later transmission over a satellite link, as well as to a data monitor for visual display of the sampled signal level data. Control of this process is obtained from a program stored in an erasable programmable read only memory (EPROM) chip on the single board computer. Power for the system is obtained from either an AC or DC source.

Data analysis is accomplished by plotting the data stored on magnetic disk by using the IBM 3033 network at the Naval Postgraduate School. The data is stored in a very compact manner onto a formatted disk. However, the disk must be retrieved once a month and a new one inserted. At this point the series of software programs illustrated in Figure 4.4 are performed to process the data. The raw data is first rearranged into a PCDOS file format. The PCDOS file is then transferred to the main frame using an established microcomputer link. The data is arranged into a sequential format by the next program. In the final stage of the processing the graphical plot

is obtained. The complete process for obtaining a graphical representation of thirty days of signal level information for ten separate channels has been reduced to hours, as opposed to days or even weeks of effort required prior to implementation of this system. The collected data is easily and rapidly correlated to any additional earthquake related data provided by the Geological Survey Office in Menlo Park, California.

B. SYSTEM HARDWARE DESIGN AND OPERATION

The block diagram of the hardware components of the computer controlled RF noise measurement and recording system is presented again in greater detail in Figure 4.6. A close analysis of each of the individual subsystems is presented.

1. Receivers

Each one of the Hamtronics VHF converter modules are designed to amplify and convert a specific frequency to the HF range. Schematic diagrams of the 38.45 MHz and the 150.75 MHz converters are shown in Figure 4.7 and Figure 4.8, respectively. Each one of the converters have 10.7 MHz intermediate frequency (IF) transformers for the mixer output circuits. The mixer output circuits themselves consist of a slug tuned coil, capacitive voltage dividers and an RCA jack to provide a 50 ohm output.

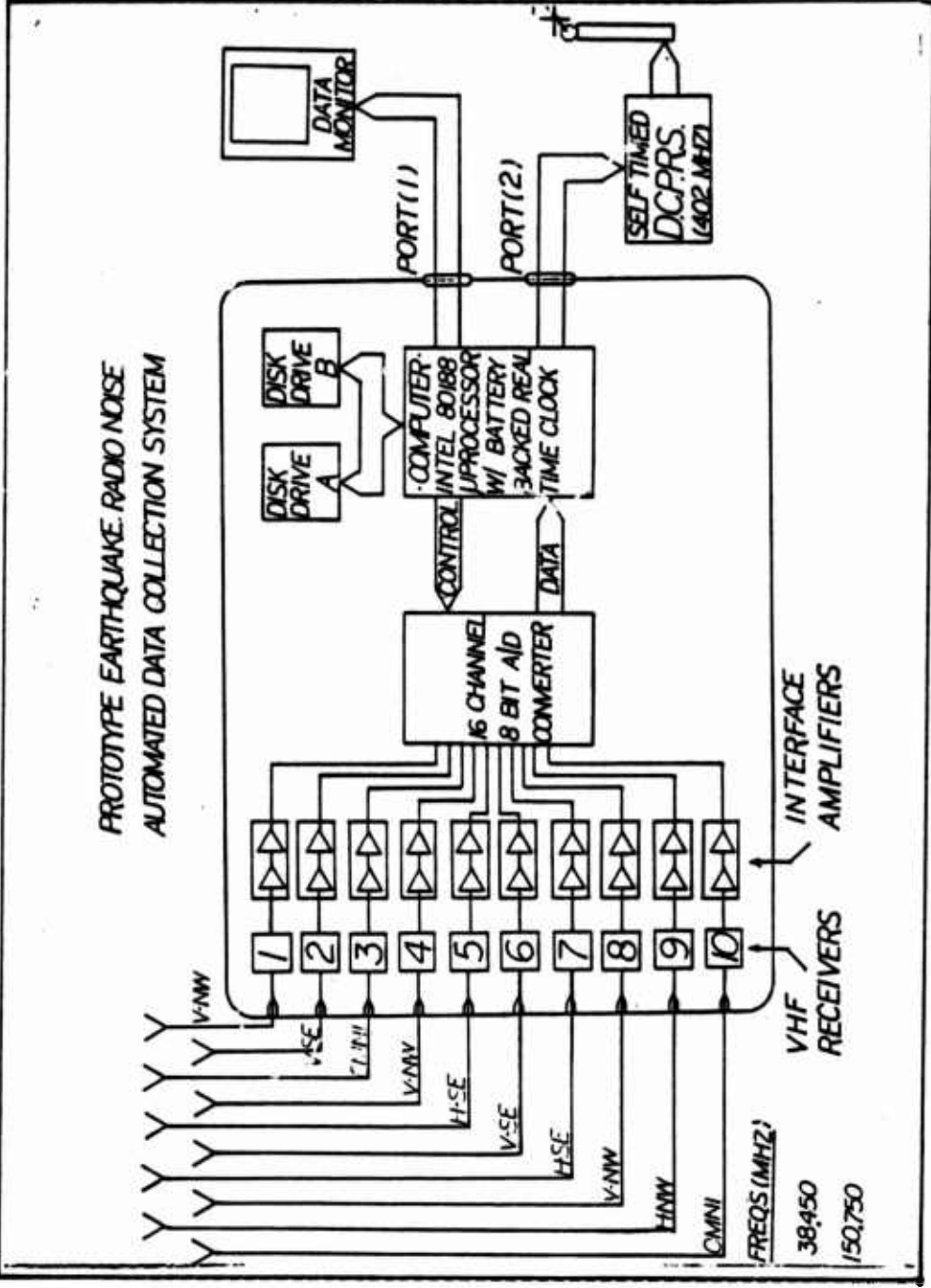

Figure 4.6 System Hardware Block Diagram

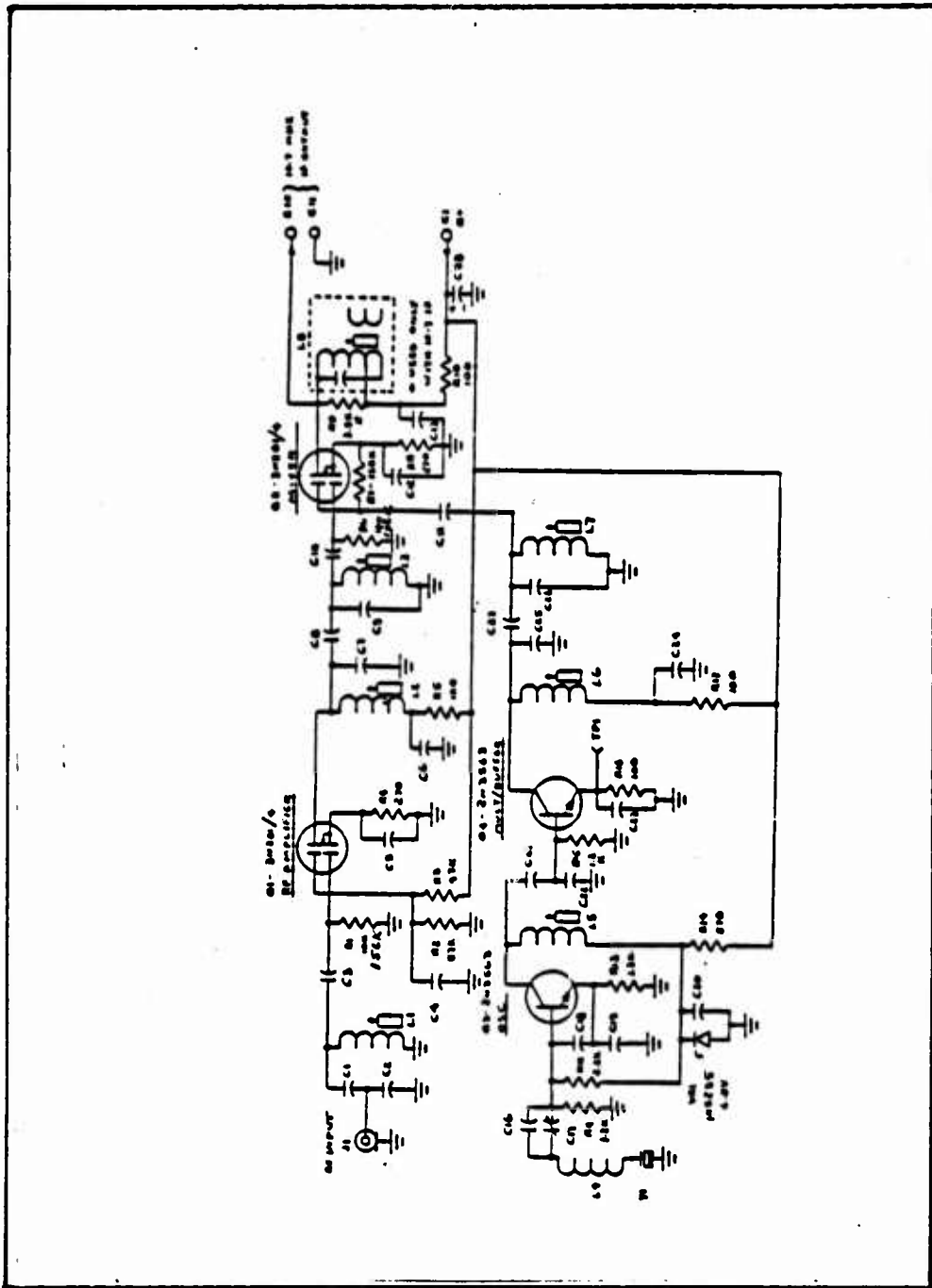

Figure 4.8 150.75 MHz VHF Converter

The 10.7 MHz IF signal is sent from the converter module to the IF/Audio module shown in Figure 4.9. The IF/Audio assembly is a highly sensitive and selective IF amplifier, AM detector, audio amplifier and squelch system which is used in conjunction with the converter to create a VHF communications receiver. The HF signal is then mixed with the 10.245 MHz oscillator frequency and then down-shifted to 455 KHz. This signal is then amplified and detected. The "S" meter output to the interface amplifier is obtained from an integral log detector.

The selectivity of this unit (plus or minus 10 KHz at -6dB and plus or minus 25 KHz at -60 dB) will permit its use as a noise floor measurement system. An optimally coupled three stage IF filter provides the selectivity against adjacent channel interference. The unit has automatic gain control (AGC) for both IF and RF, with the RF AGC being delayed for best response. Each receiver is installed in its own individual aluminum casing to prevent the detrimental effects of electromagnetic interference (EMI).

2. Interface Amplifiers

The "S" meter output from the integral log detector in the receiver is sent directly to the interface amplifier assembly shown in Figure 4.10. Previously the "S" meter output and a time pulse from a

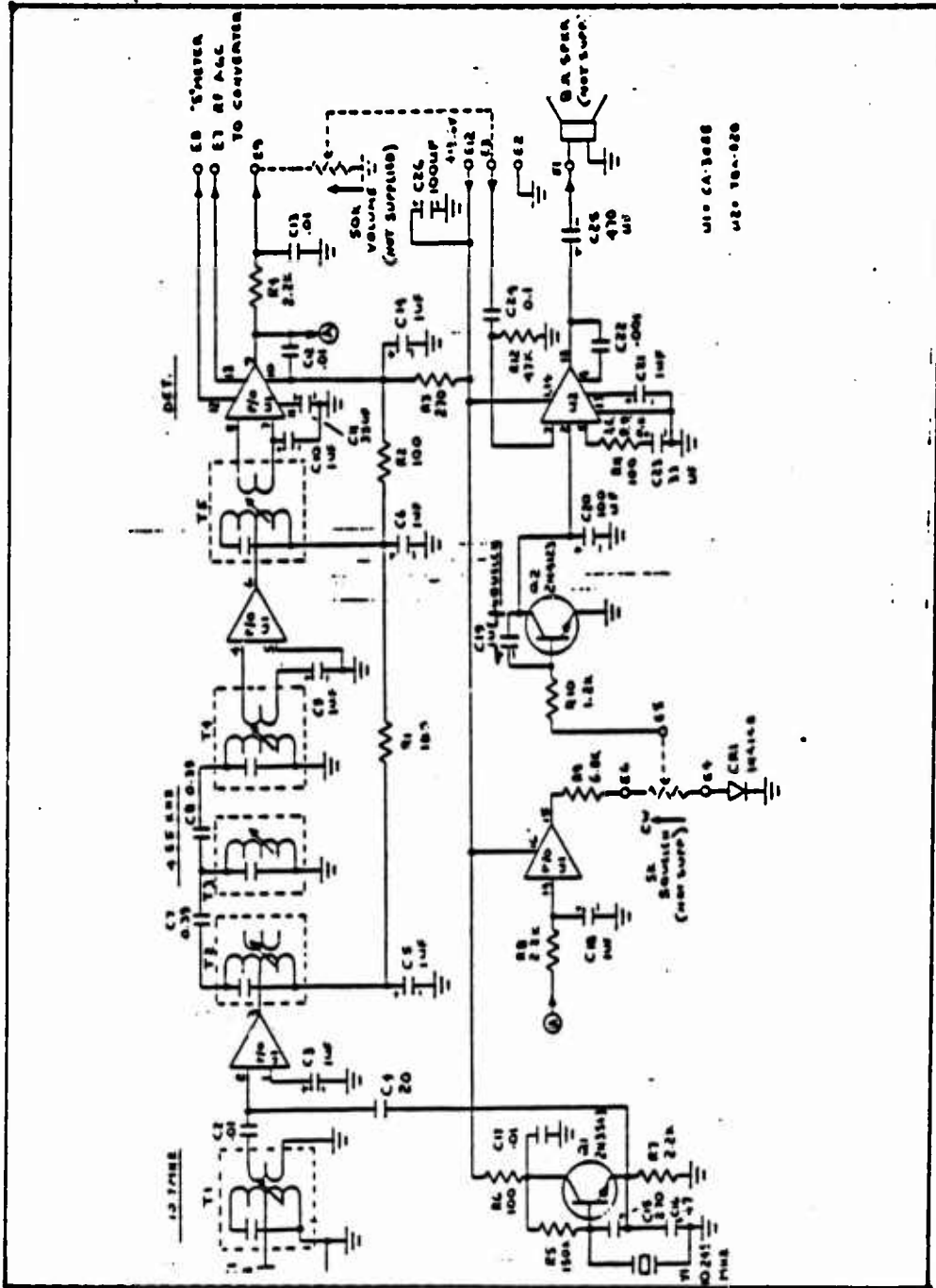

Figure 4.9 IF/Audio Assembly

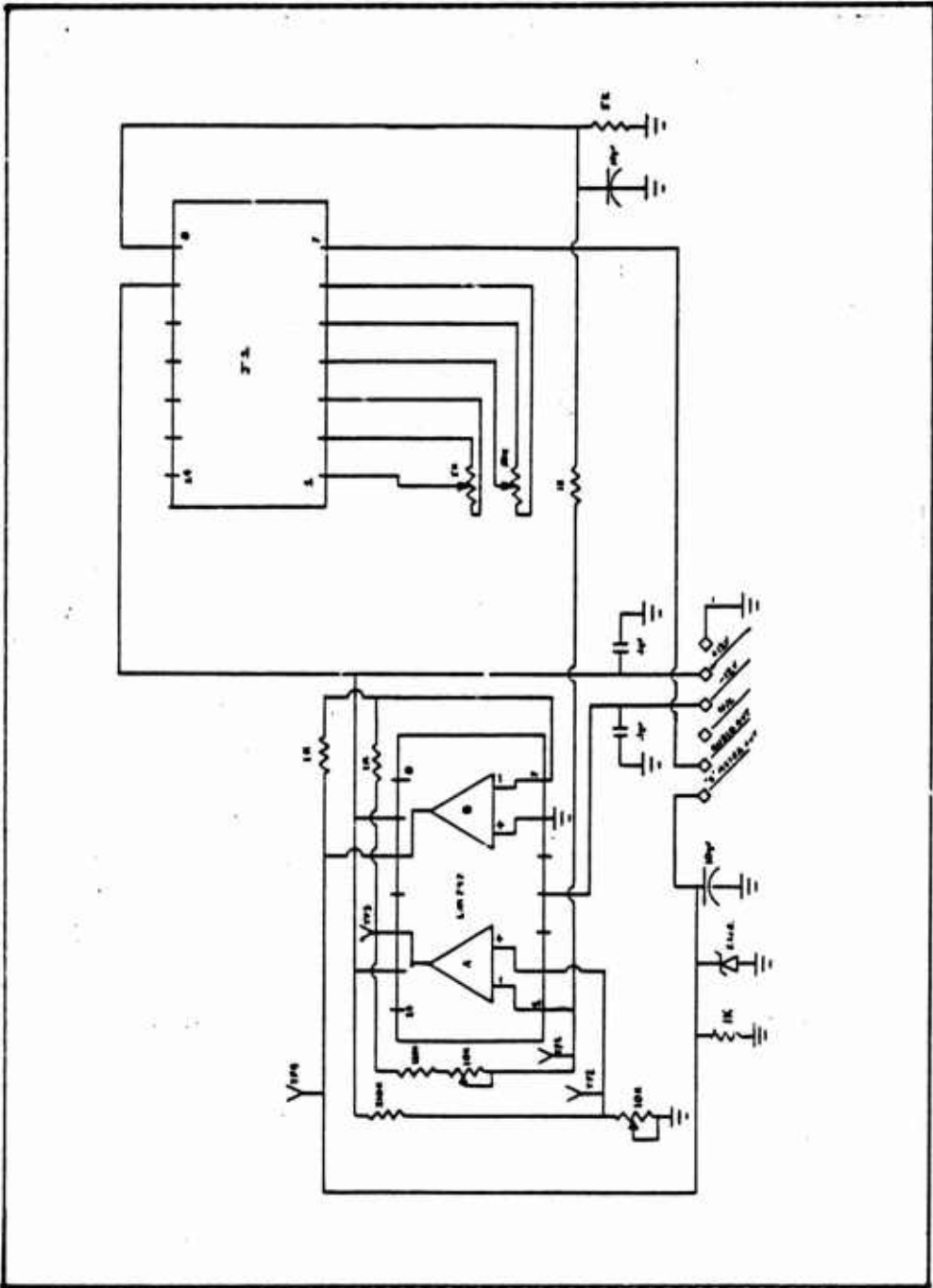

Figure 4.10 Interface Amplifier

timer assembly were integrated into one signal [Ref. 3: p. 58]. Observation of the data found the design to be sensitive to temperature and subject to nonlinear variations in output levels. In the current system a great deal of simplification has resulted by utilizing the computer as the timing and control device. The interface amplifier uses LM747 series general purpose dual operational amplifiers. As a result, no frequency compensation is required and there is an inherent balanced offset null. The "S" meter output of the receiver is amplified by the first stage, then inverted to a positive voltage using a unity gain in the second stage.

Previous data monitoring indicates that the received input signals fell in the range of zero to ten microvolts. Amplification of these signals to the millivolt range is available at the "S" meter output of the receivers. The signal is then amplified to the required range of zero to five volts by the interface amplifier assembly, corresponding to the required input range of the analog to digital converter. Figure 4.11 provides a graphical plot of the input RF signal to the receiver versus the corresponding analog to digital converter input.

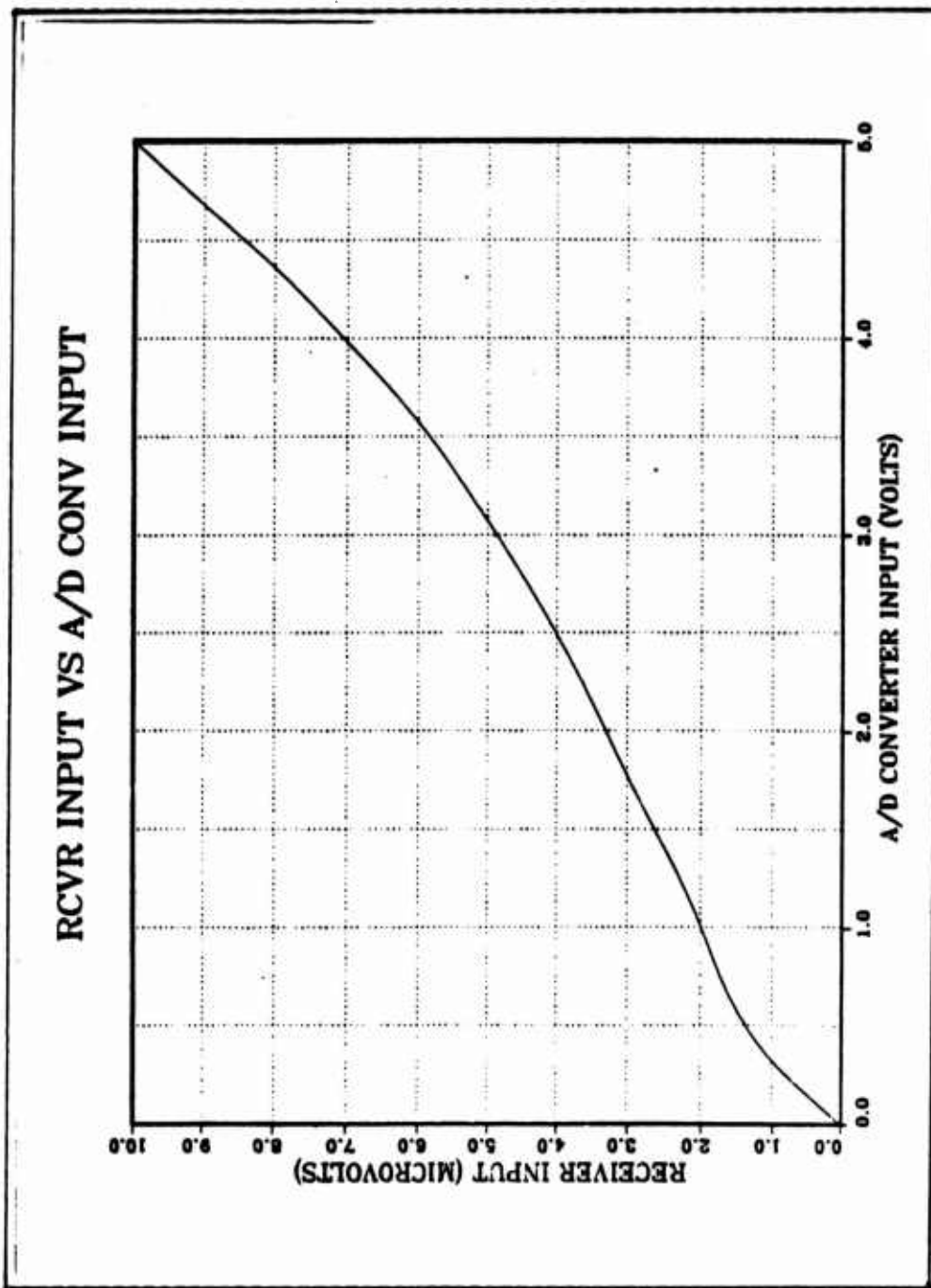

Figure 4.11 Graph of Receiver Input vs A/D Converter Input

3. Analog To Digital Converter

Quantizing of the zero to five volt signal level from the interface amplifier assembly is accomplished by an 8-bit analog to digital converter. The 16 channel 8-bit A/D converter with the associated address decoder and multiplexing circuitry are located on the Vesta OEM188 multifunction board shown in Figure 4.12. The board has been jumpered to allow single-ended analog inputs. Port 5 (P5) on the multifunction board will allow for up to 16 channels of single-ended analog input. (P5) is set up as shown in Table I.

The multifunction card has a bus interface to allow for direct connection to the microprocessor board. The bus interface has a wait-state generator to induce a 1.2 microsecond hold state to stabilize the bus during input and output procedures. The wait-state generator will slow down the microprocessor to allow for the operation of slow input/output devices such as the A/D converter. The bus is configured as a 60 conductor, dual row header that is designated Port 1 (P1) on the multifunction card. The header is connected via ribbon cable to the expansion bus connector on the single board computer itself.

4. Computer

The Vesta OEM188 single board computer using an Intel 80186 microprocessor with a clockspeed of 8 MHz

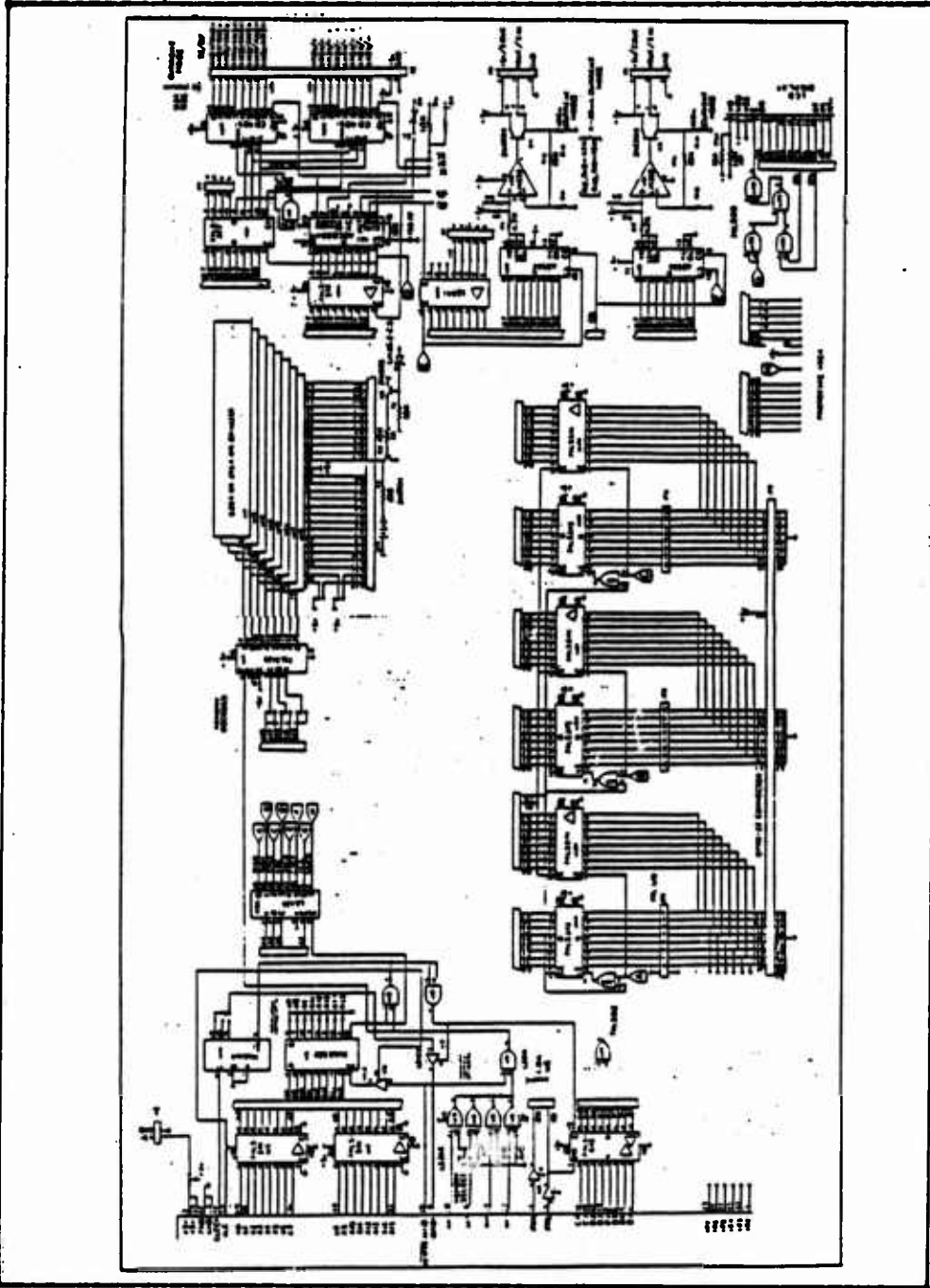

Figure 4.12 Schematic Diagram of Multifunction Board

TABLE I
 MULTIFUNCTION CARD PORT 5 (P5) PIN ASSIGNMENT
 (A/D CONVERTER INPUTS)

<u>PIN NUMBER</u>	<u>FUNCTION</u>	<u>ASSIGNMENT</u>
22	Analog (+) 0	Channel 1 Input
24	Analog (+) 1	Channel 2 Input
26	Analog (+) 2	Channel 3 Input
16	Analog (+) 3	Channel 4 Input
23	Analog (+) 4	Channel 5 Input
18	Analog (+) 5	Channel 6 Input
25	Analog (+) 6	Channel 7 Input
20	Analog (+) 7	Channel 8 Input
9	Analog (+) 8	Channel 9 Input
11	Analog (+) 9	Channel 10 Input
13	Analog (+) 10	Unassigned
19	Analog (+) 11	Unassigned
15	Analog (+) 12	Unassigned
21	Analog (+) 13	Unassigned
17	Analog (+) 14	Unassigned
7	Analog (+) 15	Unassigned
8	Ground	Ground
10	+ 5 DC	+ 5 DC

provides a maximum level of control with minimal size requirements. The control program for the microprocessor has been stored on an EPROM, allowing the disk drives attached to the computer to be used solely for data storage. Both the operating system basic input/output system (BIOS) and higher level language compiler (BASIC) are also stored in ROM directly on the board. The computer has a battery-backed real time clock (National Semiconductor MM58274) mounted on it, as well as a WD1770 disk drive controller which will support up to four 5.25 inch disk drives. In addition, an EPROM programmer is located in socket U31 on the board to allow for direct storage of programs written on the computer in BASIC. A schematic of the computer is provided in Figure 4.13.

The terminal connector located at Port 3 (P3) is designed to drive a high speed full duplex CRT terminal. This is the primary means of operator communications with the computer. The three pins on the P3 connection and their corresponding functions are described in Table II. Communications take place over an RS-232 line at a rate selected by the configuration switch located on the single board computer itself. The function of this switch is twofold. The switch provides the system with information concerning the extent of low memory. The switch also determines the baud rate at which the CRT serial channel will communicate. Table III provides the

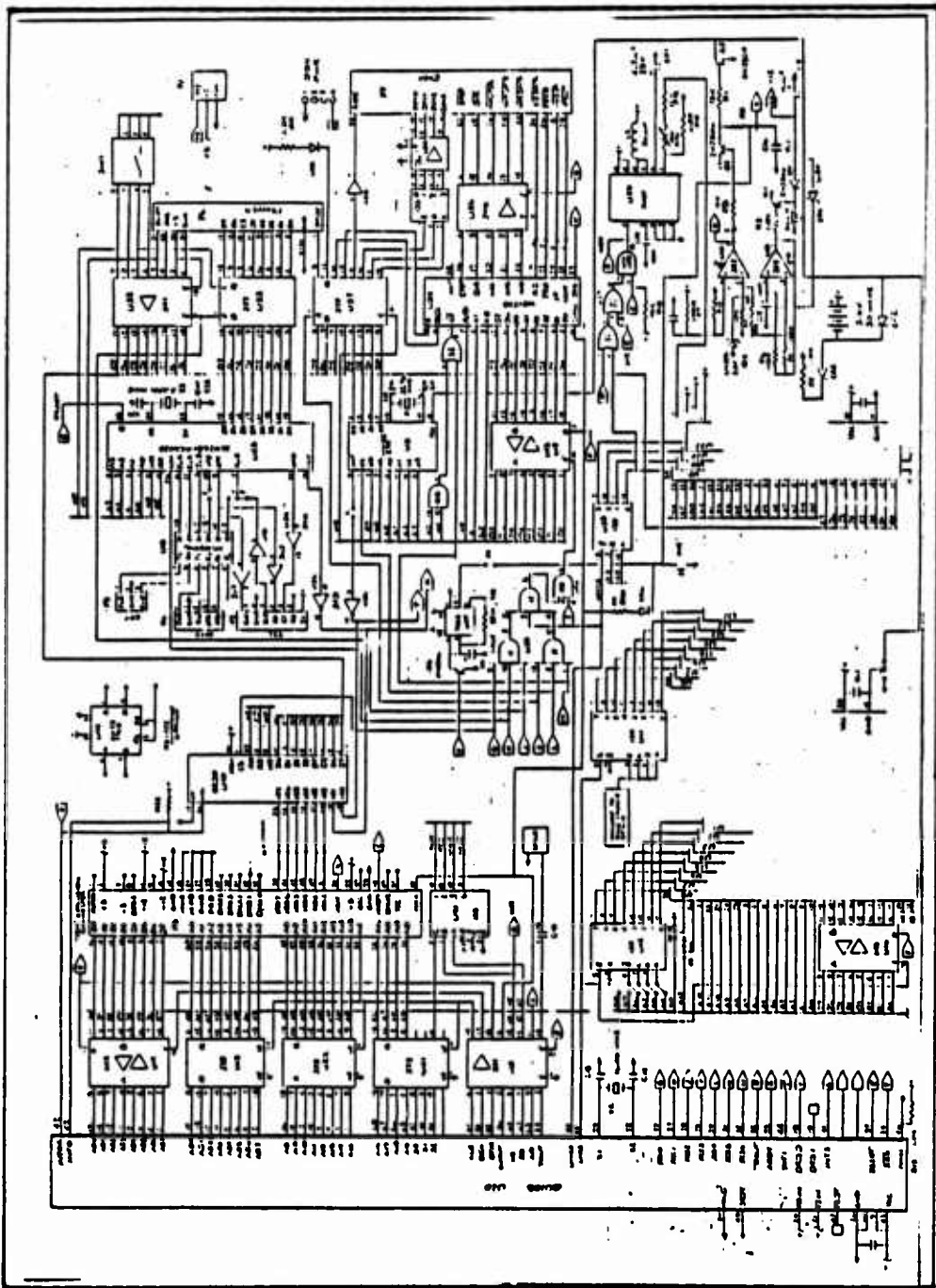

Figure 4.13 Schematic Diagram of OEM188 Computer

TABLE II
 OEM188 PORT 3 (P3) PIN ASSIGNMENTS
 (TERMINAL CONNECTOR)

<u>PIN NUMBER</u>	<u>FUNCTION</u>
1	TXD, transmitted data from computer
2	GND, signal common
3	RXD, received data from terminal

TABLE III
 OEM188 CONFIGURATION SWITCH SETTINGS

<u>SWITCH SETTINGS</u>	<u>FUNCTION</u>
0 X X X	< 64K Onboard low frequency
1 X X X	> 128K Onboard low memory
X 0 0 0	150 BAUD
X 0 0 1	300 BAUD
X 0 1 0	600 BAUD
X 0 1 1	1200 BAUD
X 1 0 0	2400 BAUD
X 1 0 1	4800 BAUD
X 1 1 0	9600 BAUD
X 1 1 1	19200 BAUD

correct settings for this switch. Switch positions are shown from left to right corresponding to pin numbers 1 to 4 (0 = closed, 1 = open). The current system incorporates only 16k of onboard low memory. The present configuration switch setting is 0-1-1-0 to accommodate terminal interfacing at a 9600 baud rate.

The power connector located at port 1 (P1) supplies the system with +5 VDC and +12 VDC. Pin 1 of P1 is connected to +5 VDC and pin 3 connected to ground. The +12 VDC connection is not required. As stated previously, up to four 5.25 inch floppy disk drives may be used. In the present arrangement, Port 7 (P7) has been connected to two disk drives via 34 conductor ribbon cable in a daisy chain. Power is supplied to the disk drives separately from the system's power supply.

Auxiliary RS-232 serial port 4 (P4) on the computer board is used to transmit the collected data to the Data Collection Platform Radio Set buffer for transmission over the satellite link at a later time. The information is sent out this port in a software programmable format. Table IV describes the pin assignments and their functions.

5. Disk Drives

Two Teac model FD-55B half-height double-sided double-density disk drives are installed in the system. The data disk is installed in the "A" drive to receive

TABLE IV
AUXILIARY RS-232 SERIAL PORT 4 (P4) PIN ASSIGNMENTS

<u>PIN NUMBER</u>	<u>FUNCTION</u>
1	TXD, transmitted data from computer
2	GND, signal common
3	RXD, received data
4	RTS, ready to send
5	CTS, clear to send

the digitized signal levels of all ten channels at each sampling interval. The "B" drive was used in the initial design of the computer control program and may be alternated with the current "A" drive for data storage. Both drives have been sealed in a dust, insect and vermin proof plexiglass container to prevent any possible damage to moving parts, the writing heads, or the data disk themselves.

Each drive has a power requirement of + 12 VDC at 0.9 amp max and + 5 VDC at 0.6 amp max. Typical power consumption while in operation is 3.9 watts and while idle 2.6 watts. The units are extremely reliable, with an operating temperature range of 4 degrees to 46 degrees centigrade and a relative humidity operating range of 20% to 80% (noncondensing).

6. Power Supply System

The system has been designed to operate using either 60 Hz, 115 volt AC power, or 12 volt DC power. Figure 4.14 shows the block diagram of the power supply system. When AC power is available, the system is designed to supply both plus and minus 12 volts DC and plus five volts DC. The battery chargers will maintain a constant charge on the 12 volt DC batteries until AC power is lost. At that time, the batteries instantaneously begin to provide the system with the

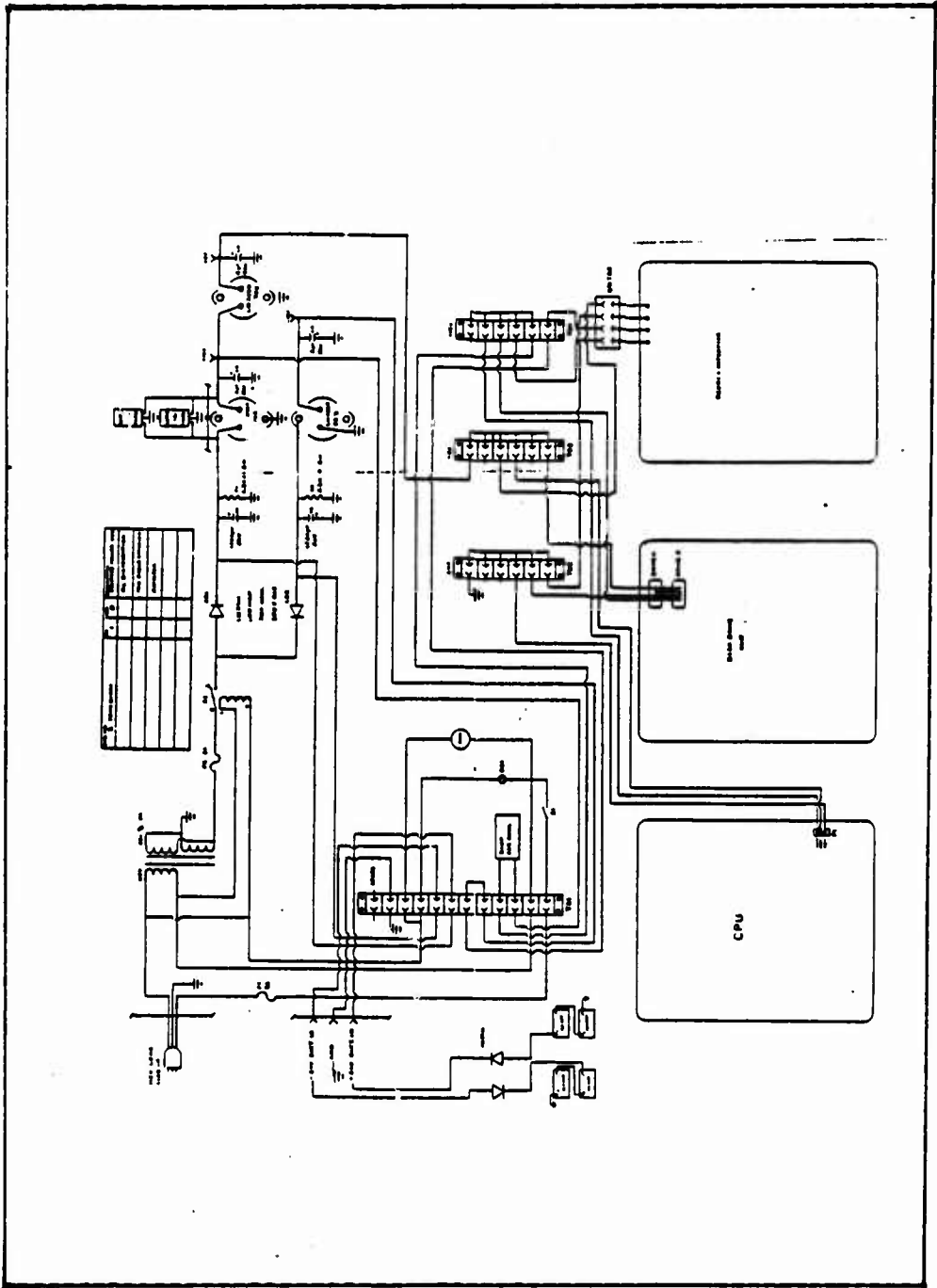

Figure 4.14 Power Supply System

required voltages. The batteries will maintain the system in full operation for approximately 48 hours. Even if the system were forced to operate without AC power for a period of time sufficient enough to drain the power batteries, the small nickel-cadmium battery on the computer board will provide power to the real time clock for up to a week. Although data storage capability will be lost during this time, the automatic reset of the computer will reactivate the control program immediately once AC power is restored.

7. Interface Connections

Two 25 pin male D-type connectors are installed on the front of the system enclosure to provide serial data output to the external peripherals. Output Port number 1 is wired to the terminal connector Port 3 (P3) of the computer. The pin connections and their corresponding functions are available in Table II. The baud rate at which the communication of data is sent out of output port 1 is set by the configuration switch on the computer. Table III provides the available options and correct settings for the switch. The switch is presently set to 0-1-1-0 to accommodate full duplex terminal interactions at a 9600 baud rate.

Data output port number 2 is connected to auxiliary RS-232 port 4 (P4) on the computer. At the time of each sampling interval the signal level data is

sent out of this port in a serial format to the Data Collection Platform Radio Set buffer. The data is stored in the buffer until it is transmitted over the 402 MHz satellite channel at the predetermined interval. Table IV describes the pin assignments and their functions. The software design section describes in detail the options available in formatting the data output. The data is presently being sent out at a rate of 110 baud from output Port 2 to the D.C.P.R.S. buffer as timing is not at all critical. The baud rate can be increased to as high as 9600 baud if necessary.

C. SYSTEM SOFTWARE DESIGN AND OPERATION

The flow chart of the software programs used to process the recorded data of the RF noise measurement system is presented again in Figure 4.15. A description of each stage of the data processing is presented.

1. Digitize.com

The program Digitize.com is stored in the model 2764 EPROM located on the Vesta OEM188 single board computer. Control of the entire system is maintained by this program. Appendix A contains a copy of Digitize.com written in the higher level language BASIC. The computer samples the ten analog input signal levels sent from the interface amplifier assemblies with an 8-bit A/D converter at a specific time interval. The digitized

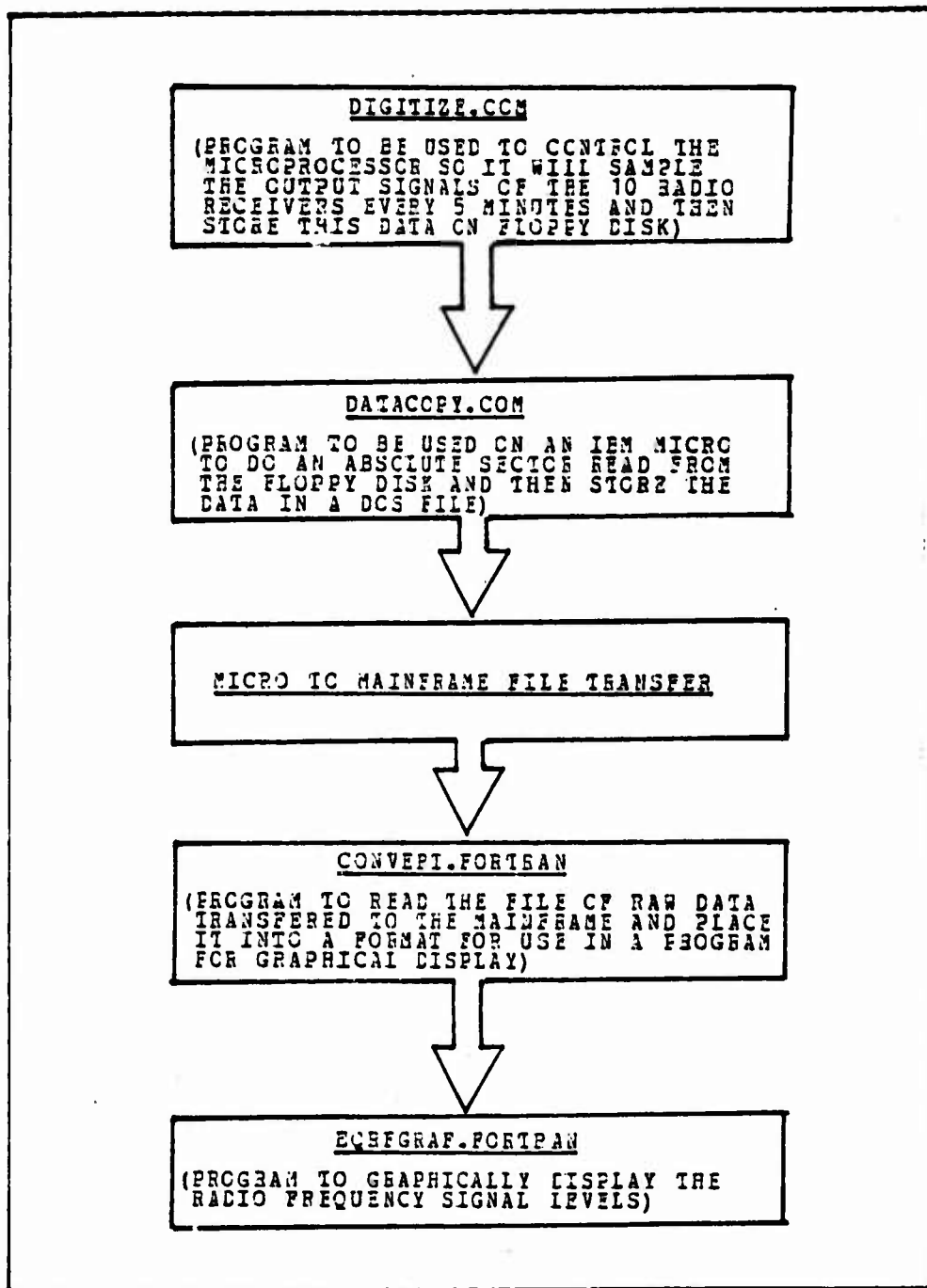

Figure 4.15 Data Processing Flow Chart

signal level data is then stored on magnetic disk. In addition, the data is sent to two external peripheral devices. The data is sent to a Data Collection Platform Radio Set buffer for eventual transmission over the satellite link and it is sent out to a monitor for visual display of the sampled signal levels.

The primary decision in the development of the program Digitize.com is the duration of the sampling interval used. There are two factors which must be satisfied in order to make the decision. The first is to ensure that enough samples are taken to accurately represent the signal levels. The desired outcome is to define long term variations in the background noise levels of the two VHF frequencies of interest, therefore the sampling may be spaced at intervals far enough apart to provide an overall trend, not necessarily every instantaneous fluctuation. The second factor involved in determining the sampling interval is available data storage space. Since there are 256 quantization steps for an 8-bit system, the analog signals are digitized and then represented at each sampling by a three digit number (100 to 355). For convenience in processing the data at a later time the data is stored in ASCII format, requiring 3 bytes of information for each sample of each signal level. With ten channels to be sampled at each interval this becomes:

$$3 \text{ bytes} \times 10 \text{ samples} = 30 \text{ bytes/sample}$$

The limiting factor is the storage space available on a magnetic floppy disk. A double-sided double-density floppy has 80 tracks on it for use. There are 9 sectors per track and 512 bytes per sector. The first sector of any disk cannot be used because it contains formatting information. Solving for the available storage space:

$$80 \text{ trks} \times 9 \text{ sec/trk} \times 512 \text{ bytes/sec} - 512 = 368,128 \text{ bytes}$$

If a two byte time stamp is added to the end of each sample to serve as a sampling period spacer there will be 32 bytes used at each interval. In this way the sectors will be evenly filled with 16 samples:

$$30 \text{ bytes/sample} + 2 \text{ bytes/sample} = 32 \text{ bytes/sample}$$

$$512 \text{ bytes/sector} / 32 \text{ bytes/sample} = 16 \text{ samples/sector}$$

Solving for the number of sectors available on a disk:

$$368,128 \text{ bytes} / 512 \text{ bytes/sector} = 719 \text{ sectors}$$

The number of 32 byte samples which can be taken is:

368,128 bytes / 32 bytes/sample = 11504 samples

or, alternatively solving for this quantity:

719 sectors x 16 samples/sector = 11504 samples

The final decision to have a five minute sampling interval is a compromise between the amount of available data storage space and the desired degree of accuracy. This interval accurately represents the expected overall tendencies of the background noise levels and allows the following quantity of time for data storage:

5 min/sample x hr/60 min x day/24 hrs = 288 samples/day

11504 samples / 288 samples/day = 39.94 days of space

A special code to store the data in a specific location within a specific sector based on the actual date and time of the sampling period has been devised to create a sequential storage method for the data. Because of this, the time limit for storing the data on a disk is limited to the same time of the same day of the month following the insertion of the data disk or 31 days, whichever is least.

All of the sectors to be written to on the disk are accessed sequentially. To assign the current sector and location within the sector to which an absolute disk

write operation is completed, the following calculations are made:

$N = \text{sample number}$

$N = 12 * \text{hour} + \text{minutes}/5 + \text{date}*288$

$S = \text{sector number}$

$S = N / 16$

$P = \text{data pointer to a specific location in the sector}$

$P = \text{MOD}(N,16) * 32$

The date, as well as the time in hours and minutes are obtained from the clock chip and the calculations are made for the write operation following each sampling interval. As a result, there is no overwriting of data for a month. Only up to a month of data for the ten sampled signal levels can be stored on a disk. It must then be removed from the noise recording system disk drive and a new blank formatted disk (using PC DOS 2.1 or later format) inserted to collect another month of data. It is important to note that the 32 byte data samples are stored on the disks by an absolute write. The data is not in a file structure and therefore cannot be observed on a computer at this time. It is not until the next step in the data processing is accomplished that the data can be observed by the user.

2. Datacopy.com

The program Datacopy.com as shown in Appendix B is the second stage of the data processing shown

previously in Figure 4.15. The program is written using a public domain version of the higher level language FORTH and is stored on an IBM PCDOS 2.1 format disk as an executable file. The FORTH language was found to be the simplest and quickest means of accomplishing the desired outcome. Also stored on the same disk is an empty data file called Acquired.dat which will eventually store all of the data acquired on the data disk by the RF noise recording system. The purpose of the program Datacopy.com is to perform an absolute read operation on the data disk and then copy the data into the DOS file Acquired.dat. Once the data is in the DOS format file it is readily available to the user.

The transfer operation must be accomplished on an IBM Personal Computer with two disk drives booted with a DOS of version 2.1 or later. To perform the data transfer the following steps must be accomplished:

- a. Place the disk with the two files Datacopy.com and Acquired.dat on it into disk drive "A" of the computer.
- b. Place the data disk retrieved from the noise recording system with up to a month of data on it into disk drive "B" of the IBM computer.
- c. Type in the command "Datacopy Acquired.dat" at the system prompt. The program will direct the user from this point.

Data is transferred from the data disk in 1K blocks and the program continuously indicates how many "K" of data have been transferred into the file

Acquired.dat. The transfer can be stopped at any time by pressing any key. If a key is pressed the user will be left in the FORTH environment. To return to DOS, type in the command "bye". To transfer a complete month of data (278K) takes about 12 minutes. Once the operation is completed and the program has stopped transferring, press <CTRL>C or <CTRL> ALT DEL. The entire contents of the file Acquired.dat can be observed by entering the command "type Acquired.dat". The data is now stored in a DOS file format and the user is ready to proceed with the next step of the data processing.

3. Micro to Mainframe File Transfer

To allow for greater versatility and storage capability, the DOS file Acquired.dat created by Datacopy.com is sent to the IBM 3033 host computer using the 3270 terminal mode file transfer technique. The 3270 terminal mode file transfer is a method of file transfer that can only be used when the PC is operating as a 3278 model 2 display terminal and is connected to an IBM host computer running either SIM3278/VM or SIM3278/VTAM [Ref. 13:p. 8-7]. To perform a 3270 terminal mode file transfer the IBM PC to be used must be connected to either SIM3278/VM or SIM3278/VTAM on the host computer. A number of IBM personal computers with this capability are located at the Naval Postgraduate School. Reference 13 provides complete documentation on the file transfer process.

Using a terminal meeting the required specifications the command "send Acquired.dat Acquired Data A1 (ASCII crlf" is entered. The disk with the file Acquired.dat containing the signal level data must be in the PC disk drive. The PCDOS file Acquired.dat is transferred to the users "A" disk into a file designated as FN FT Acquired Data. The data will be sent sequentially to the file in the order of the days of the month, i.e., from the date 01 to the date 31. If during any of these days there was no data collected, the file will be blank at that point.

4. Convert Fortran

Upon the completion of the microcomputer to host computer file transfer, the next step in the processing of the data is to rearrange or "convert" the data in the newly created acquired data file into a more convenient format. The program Convert Fortran as shown in Appendix C is designed to accomplish this. Once the data is rearranged by this program it can be used as a hardcopy sequential record of the signal level data. The new format will also allow for plotting of the data using DISSPLA (Display Integrated Software System and Plotting Language).

One month of data transferred to the main frame file Acquired Data is approximately 3900 lines in length. The 30 character segments of data (10 channels of data

with 3 digit characters used to represent each signal level, i.e., 100 to 355) are written consecutively into the 80 character per line file. Each 30 character data segment is separated by a two character spacer (00, 01, 02, 03, 04, or 05). The program Convert Fortran will read the 30 character segments one at a time out of the Acquired Data file, assign a sequential number, then write them to the new file. The following steps must be followed to accomplish the rearrangement:

- a. Change the FN FT of Acquired Data into FN FT File FT08F001 and save this newly named file.
- b. Ensure that the variable named ISTART in the program Convert Fortran is assigned the correct numerical value. ISTART is determined by the amount of data characters from the last 30 character segment in the second row of the data file Acquired Data which have not overflowed with the rest of the segment onto the next line. An example is presented in the system performance section of this thesis.
- c. Run the program Convert Fortran and save the rearranged datafile by issuing the following sequence of commands at the appropriate times:
 - "Fortvs Convert"
 - "Record on"
 - "Load Convert(start"
 - "Record off"
- d. Temporarily store this new sequentially arranged data in any FN FT. Delete any extraneous entries from the file so that only the sequential numbering and data remains in it.
- e. Erase the file previously designated File FT08F001 in Step a. (the original is still in the file Acquired Data).

- f. Change the FN FT, of the file created in Step d. to File FT08F001.

Once these steps are completed the user has a sequentially arranged file of the 30 character segments obtained during each sampling interval. A copy of this can be obtained by the command "print". The data in File FT08F001 is also prepared for the final stage of the data processing.

5. Eqrfggraf Fortran

In this final step of the data processing a graphical representation of the data in File FT08F001 created by Convert Fortran is obtained. The user must be located at a terminal with an attached Tektronic 618 graphics monitor to run the program Eqrfggraf Fortran shown in Appendix D.

Once the necessary minor modifications are made to the program Eqrfggraf Fortran to provide the desired output , the following commands are issued:

"Fortvs Eqrfggraf"

"Dissspla Eqrfggraf"

A plot of the selected channel(s) of data is displayed on the Tektronic 618 monitor. A hard copy of the graphs may be obtained at this time.

D. SYSTEM PERFORMANCE

A listing of selected calibration settings e input radio frequency signal strengths in microvolts to the corresponding analog to digital converter input

voltage levels and quantized signal levels is shown in Table V. The system was placed into operation in November of 1986. The input signals were sampled and recorded on magnetic disk. The data recorded directly onto the disk was transferred to the DOS file Acquired.dat. Completing the next required step of data processing, the DOS file was transferred to the main frame and stored in the file Acquired Data. A copy of a portion of this file is shown in Figure 4.16. The program Convert Fortran rearranged the data into the sequential format file called File FT08F001 as shown in Figure 4.17. The final step of data processing was completed by running the program Eqrfgraf Fortran and the plots obtained are shown in Figures 4.18 to 4.27.

TABLE V
SYSTEM PERFORMANCE LEVELS

Input RF signal level to the receivers (microvolts)	Corresponding input voltage level to the A/D converter (volts)	Corresponding quantized signal level stored in data file (unitless)
0.0	0.00	100
1.0	0.32	116
2.0	1.00	151
3.0	1.77	190
4.0	2.49	227
5.0	3.07	257
6.0	3.57	282
7.0	3.98	303
8.0	4.36	322
9.0	4.68	339
10.0	5.00	355

CHANNEL 01 SIGNAL LEVELS

FOR 14 - 17 NOV 1986

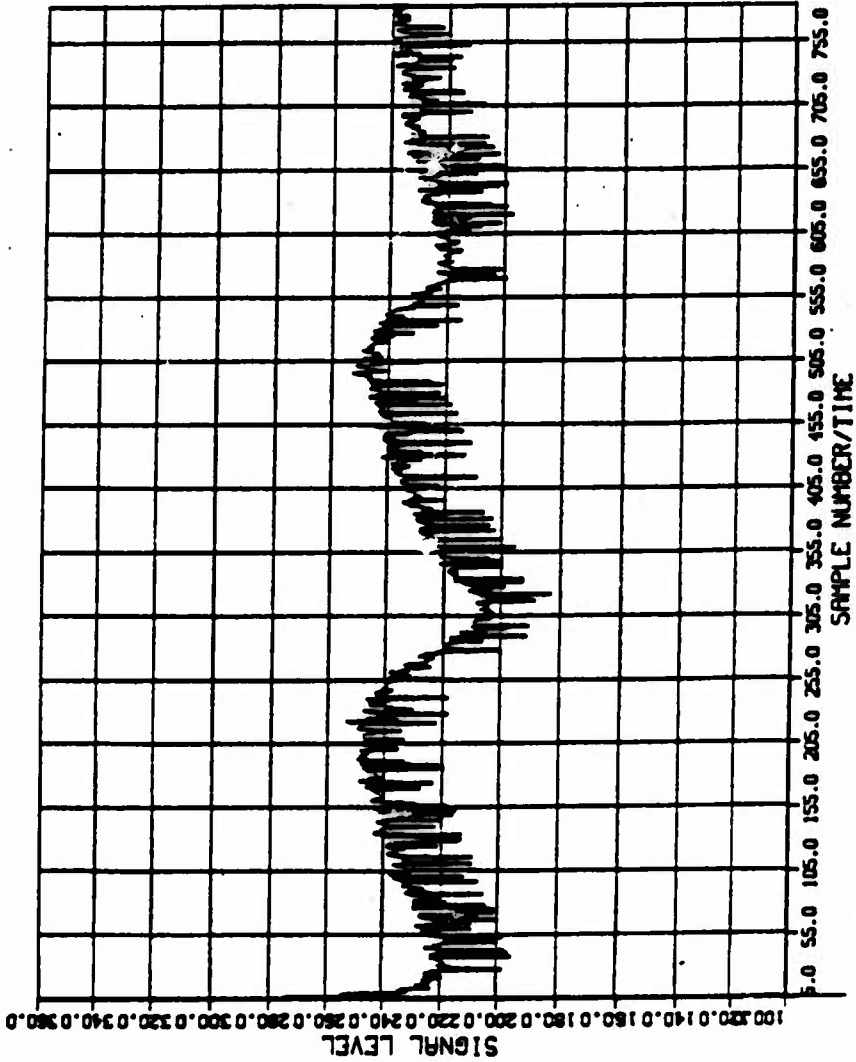

Figure 4.18 Channel 01 Signal Levels

CHANNEL 02 SIGNAL LEVELS

FOR 14 - 17 NOV 1986

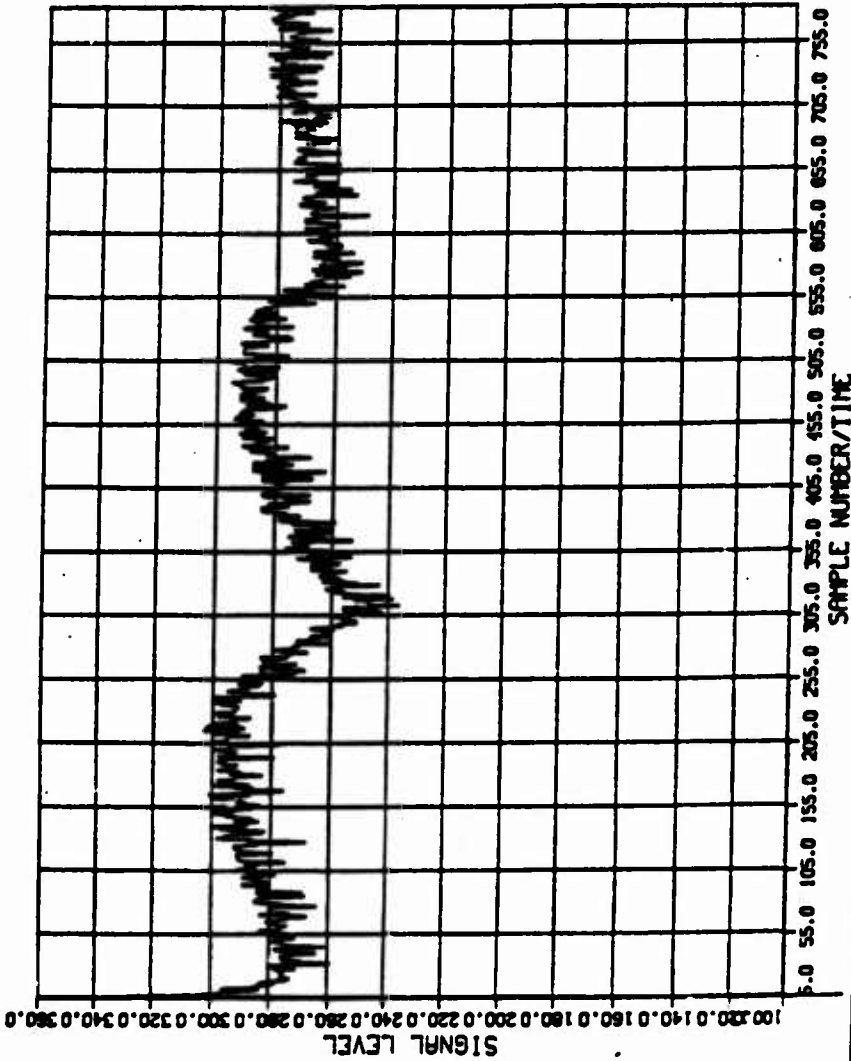

Figure 4.19 Channel 02 Signal Levels

CHANNEL 03 SIGNAL LEVELS

FOR 14 - 17 NOV 1986

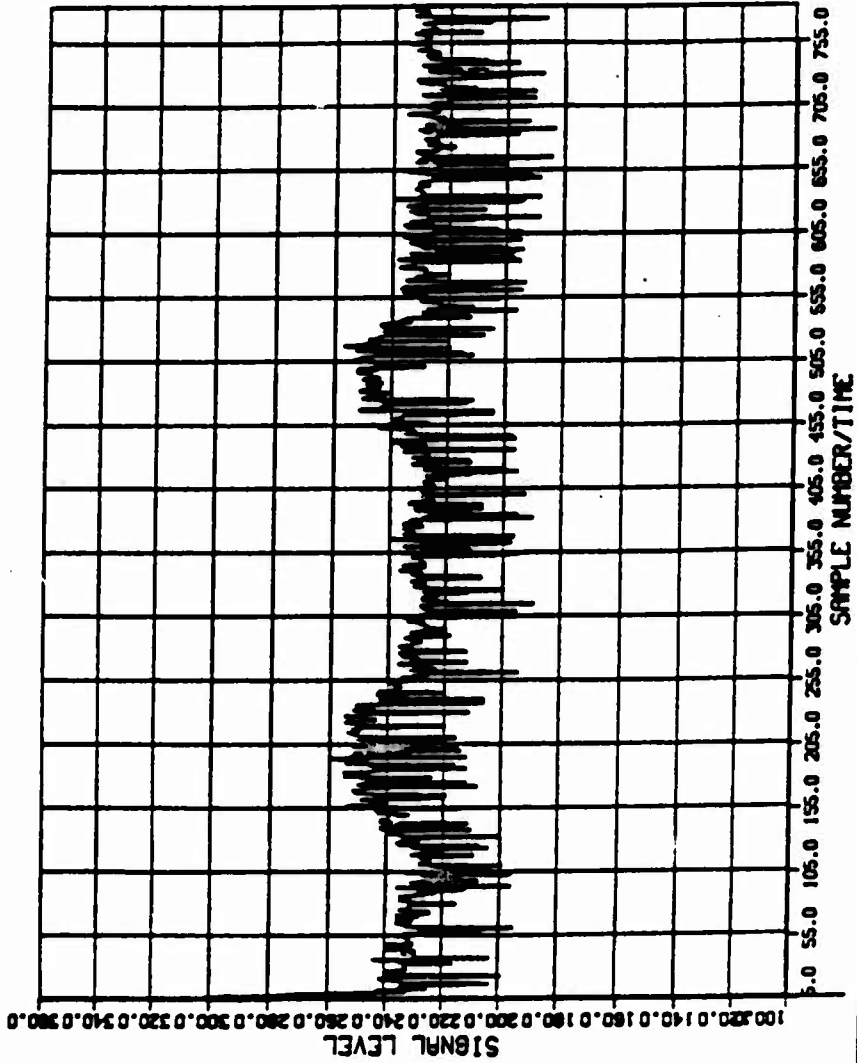

Figure 4.20 Channel 03 Signal Levels

CHANNEL 04 SIGNAL LEVELS

FOR 14 - 17 NOV 1986

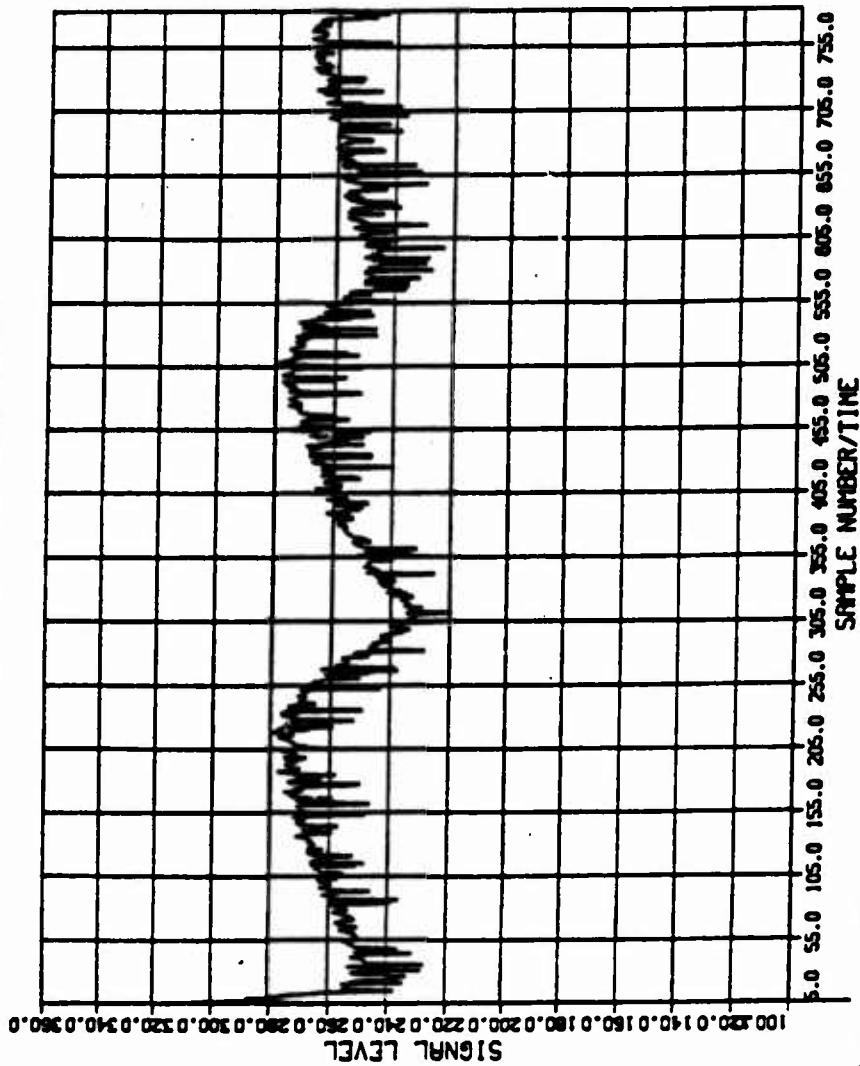

Figure 4.21 Channel 04 Signal Levels

CHANNEL 05 SIGNAL LEVELS

FOR 14 - 17 NOV 1986

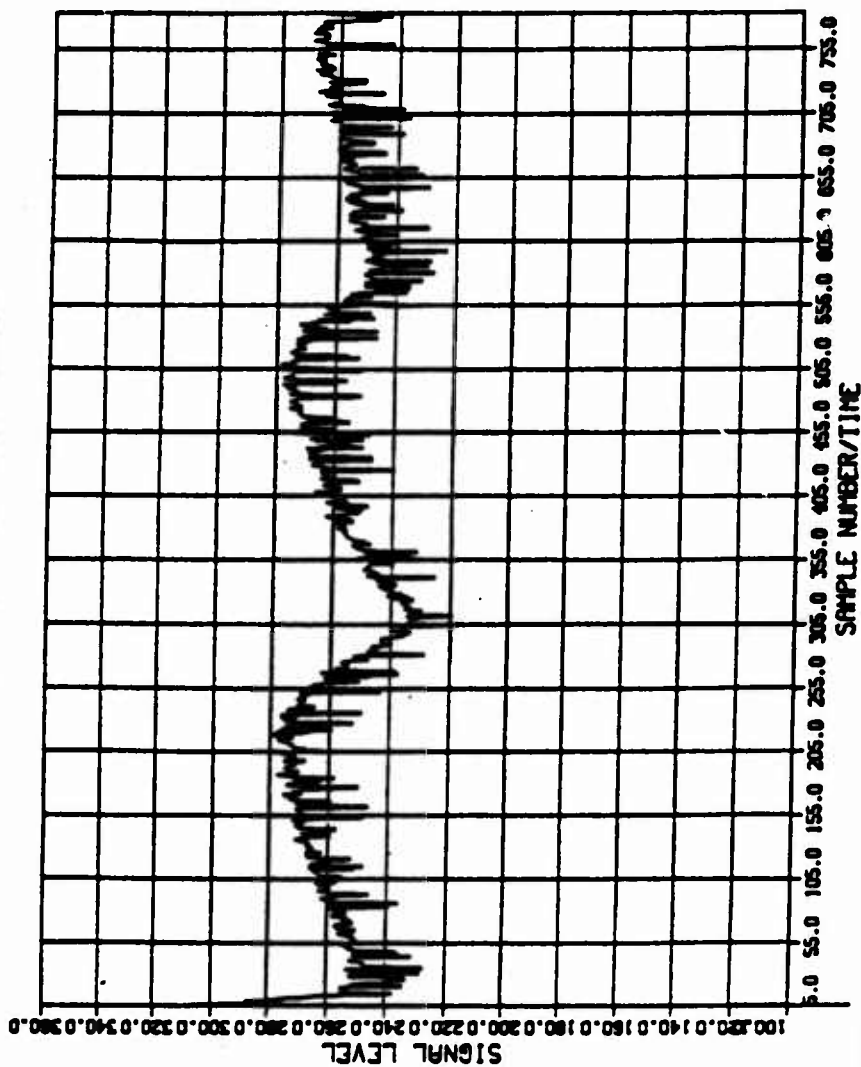

Figure 4.22 Channel 05 Signal Levels

CHANNEL 06 SIGNAL LEVELS

FOR 14 - 17 NOV 1986

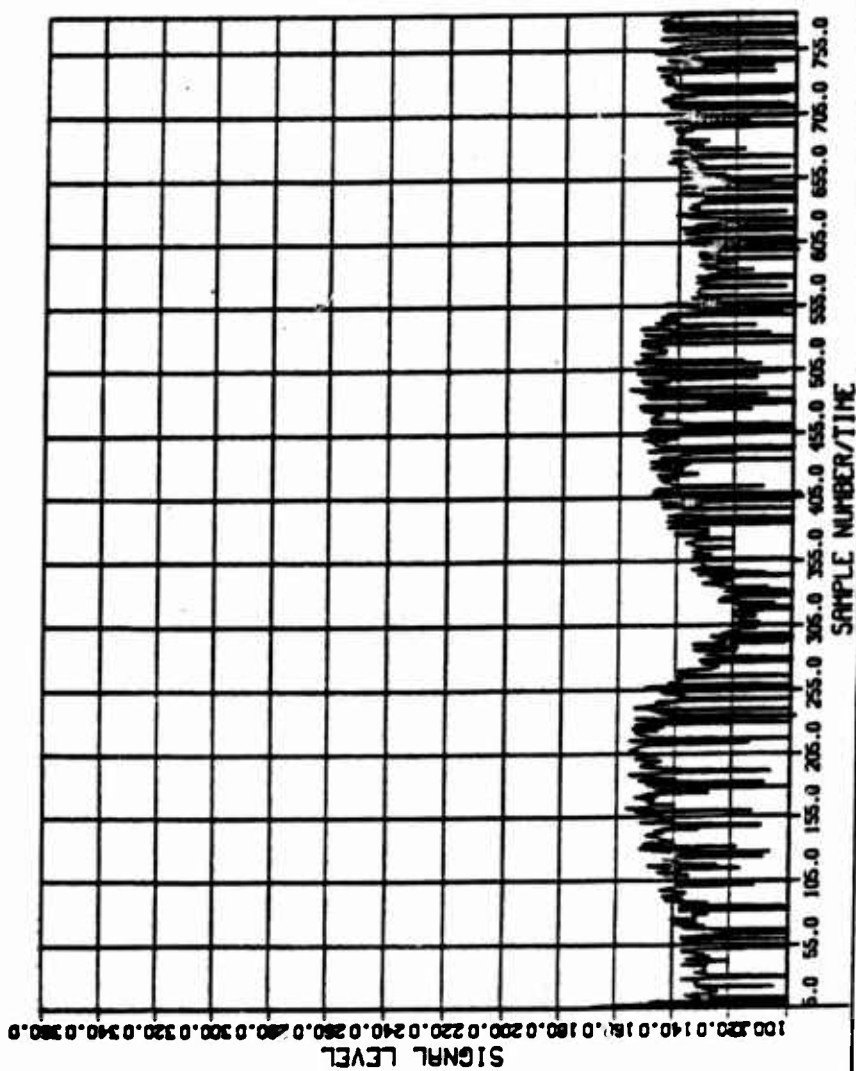

Figure 4.23 Channel 06 Signal Levels

CHANNEL 07 SIGNAL LEVELS

FOR 14 - 17 NOV 1986

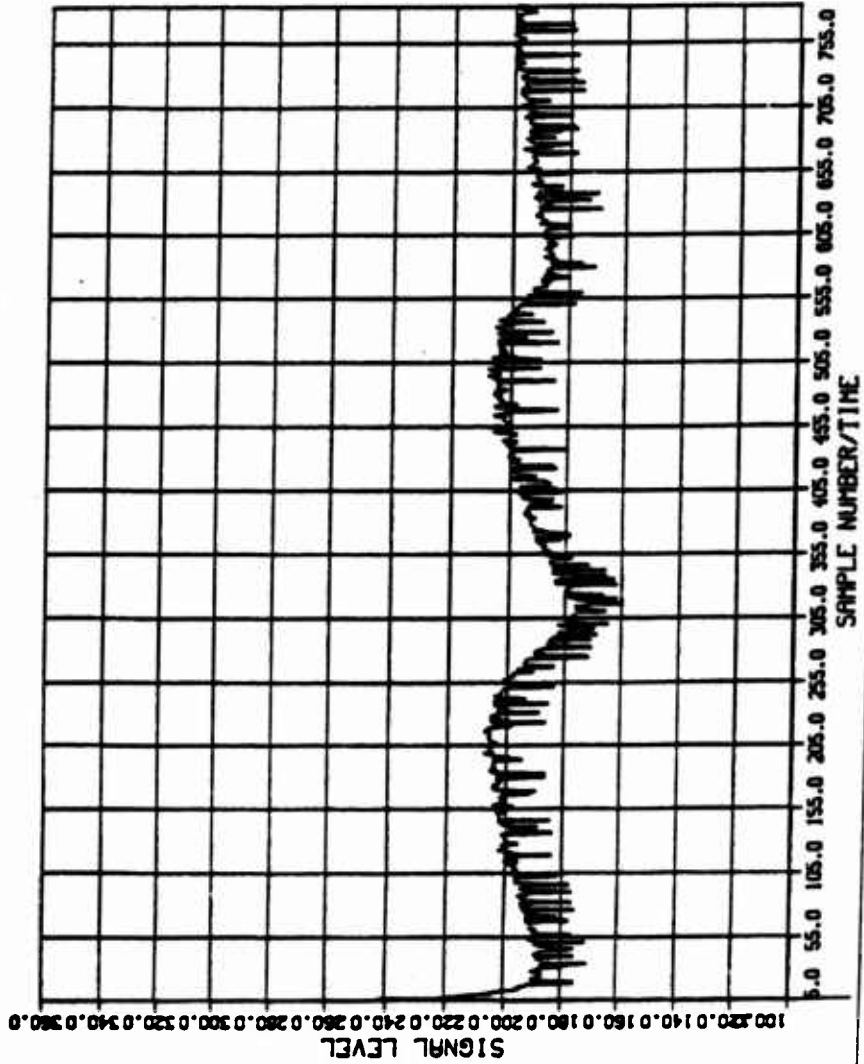

Figure 4.24 Channel 07 Signal Levels

CHANNEL 08 SIGNAL LEVELS

FOR 14 - 17 NOV 1986

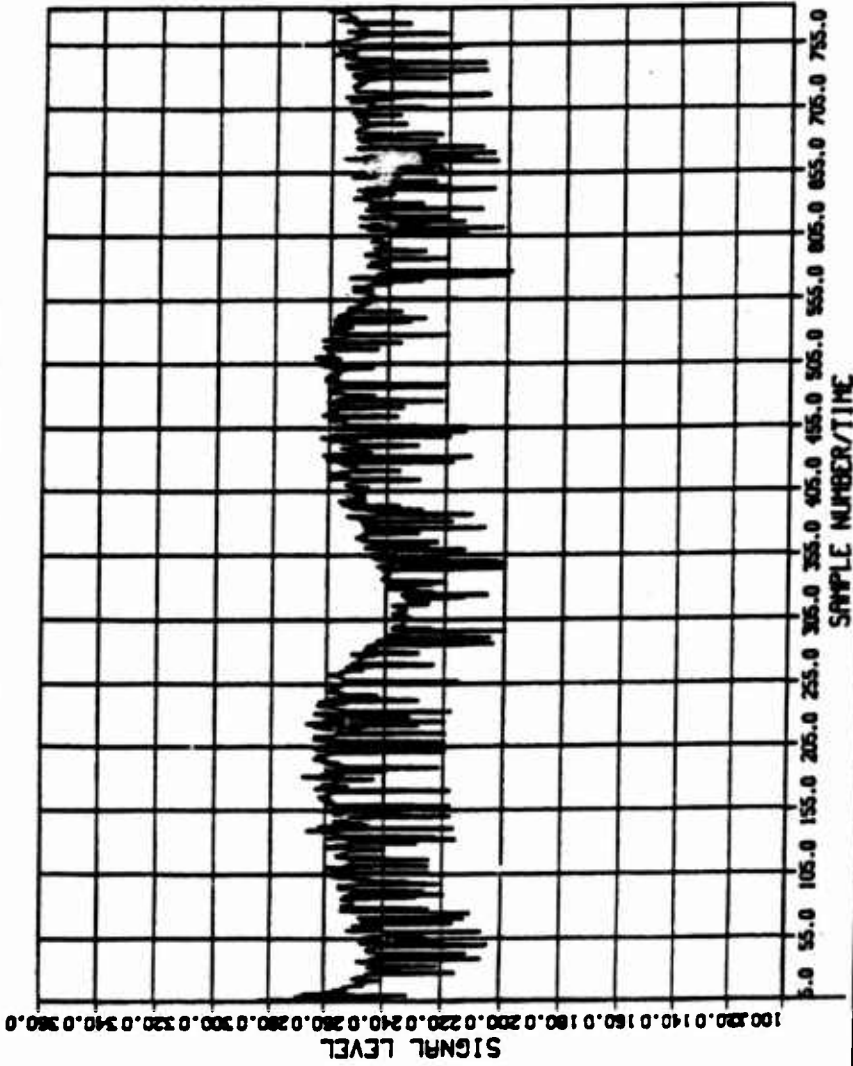

Figure 4.25 Channel 08 Signal Levels

CHANNEL 09 SIGNAL LEVELS

FOR 14 - 17 NOV 1986

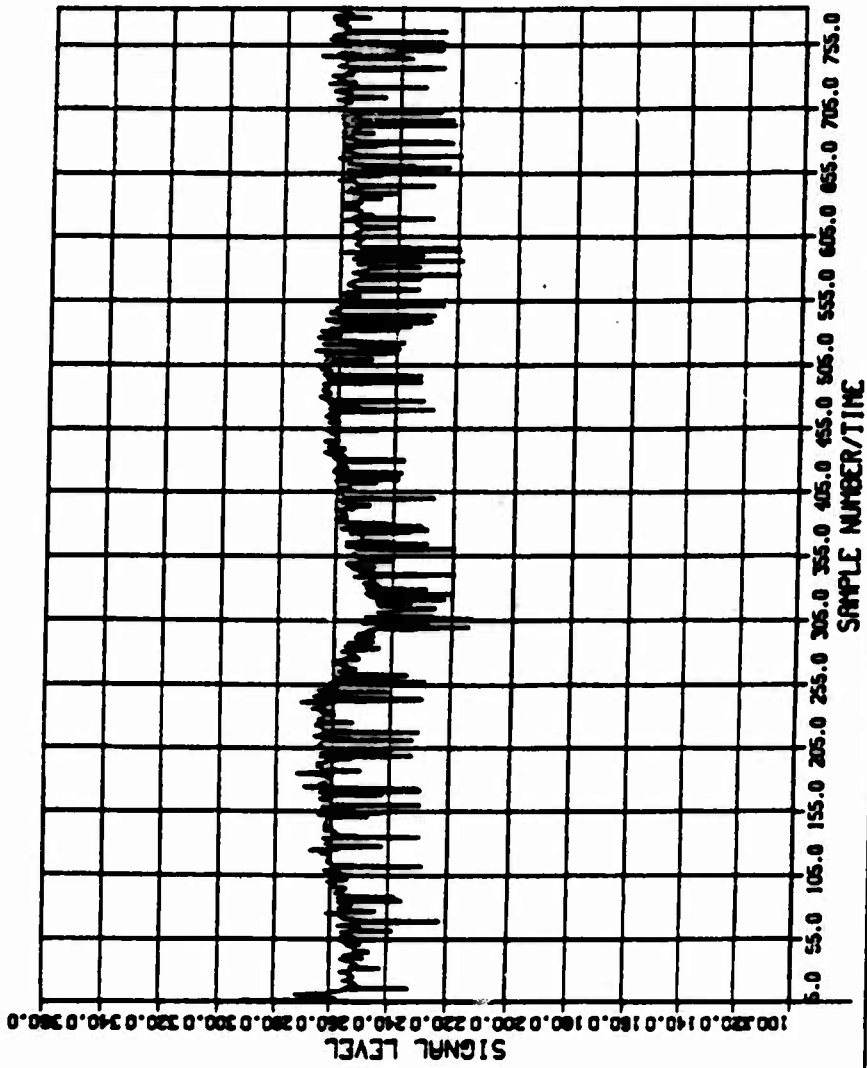

Figure 4.26 Channel 09 Signal Levels

CHANNEL 10 SIGNAL LEVELS

FOR 14 - 17 NOV 1986

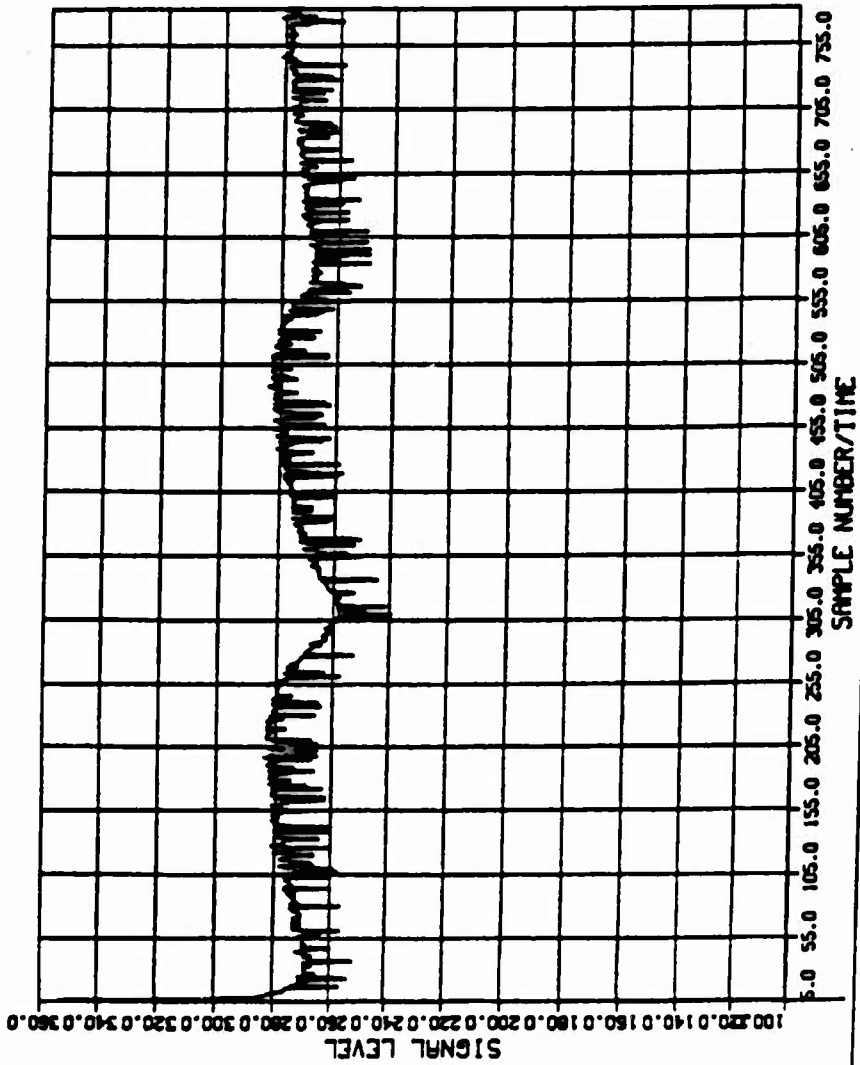

Figure 4.27 Channel 10 Signal Levels

V. RECOMMENDATIONS AND CONCLUSIONS

A. RECOMMENDATIONS

There are several avenues of research to be pursued which could provide further correlation between precursory radio frequency emissions and earthquake activity. By utilizing the present design of the VHF noise measurement and recording system, several modifications to the hardware and software may provide more explicit results. Limitations would of course be related to the available funding.

The range of frequencies to be monitored for activity could be vastly increased by the introduction of a scanner receiver in place of the ten fixed-range receivers. There are a large number of commercial grade scanner receivers capable of measuring signals in the KHz range to as high as the GHz range. Many of them are fully programmable, allowing the user to select a large number of channels to be scanned. The scanning of the signals at the selected frequencies would need to be synchronized to the sampling rate of the analog to digital converter. This would require the design of external digital circuitry. By incorporating a log-periodic antenna array and a wideband amplifier into the system with the scanner receiver, a much wider band could be monitored for radio frequency activity.

An increase in the measurement accuracy of the VHF signal levels being monitored could easily be achieved by increasing the sampling rate. A simple software modification to the program Digitize.com would accomplish this. However, the increased sampling rate would also require having a much larger data storage capability. The use of hard disk drives, or even magnetic bubble memory units for data storage would accommodate the increased signal sampling rate, but the expense involved must be considered.

Now that the recorded data is in a very manageable form, the potential for much more detailed long range data analysis exists. Programs to examine the recorded signal level data could be created to perform a number of mathematical operations. It will be important to search the data over a long period of time to determine routine patterns and cycles. Once a firm data base has been established, the ability to distinguish any unusual disturbances may provide a deeper understanding of the phenomena being observed.

B. CONCLUSIONS

The design, construction and implementation of the computer controlled radio frequency noise measurement and recording system for detection in the 30.45 MHz and 150.75 MHz range provides a means of analyzing acquired data rapidly and accurately. The interfacing of this

system to a digital satellite link adds a reliable remote sensing capability. Future analysis of the data may enhance the potential for using radio frequency emissions as a precursor to future earthquake activity.

At the present time more research is required to establish a correlation between radio frequency emissions and earthquake activity. To overcome the credibility gap which presently exists in the use of RF emissions as a precursory device, a detailed documentation of the acquired data must be accomplished. In this way, a basis for future predictive capability can be established. Several criterion need to be identified to determine radio frequency precursory anomalies. First, the day to day normal activity pattern must be clearly and quantitatively defined by extensive sampling of the background noise activity. Second, the anomalous RF activity has to be defined quantitatively and then evidence shown that the "anomaly" was significant or unique. Third, a physical or casual link between the RF anomaly detected and an actual earthquake must be established. In this way the radio frequency emissions may then be absolutely defined as precursory.

MAIN PROGRAM:

```

1000 GOSUB 9000:REM INITIALIZATION ROUTINES
1100 GOSUB 2000:REM WAIT FOR 5 MINUTE DATA TIME
1120 GOSUB 3000:REM GET 10 SAMPLES
1140 GOSUB 4000:REM CONVERT 10 SAMPLES TO ASCII
1200 READ(B,S): REM READ SECTOR FROM DISK INTO MEMORY
1220 GOSUB 5000:REM PUT NEW ASCII IN BUFFER
1300 WRITE(B,S):REM WRITE BUFFER BACK TO DISK
1500 GOSUB 7000:REM VERIFICATION OF SAMPLING CRITERION
1600 GOSUB 8000:REM OUTPUT CHANNEL DATA TO TERMINAL/D.C.P.R.S.
1900 GOTO 1100: REM LOOP

2000 REM - WAIT FOR 5 MINUTE INTERVAL AND CALCULATE CURRENT SECTOR
2100 T=CLOCKREAD:REM          GET NEW TIME
2120 IF(T=U) GOTO 2100:REM     IS OLD TIME+NEW TIME
2140 U=T:REM                  UPDATE OLD TIME
2200 IF(MOD(T,5)<>0) GOTO 2100:REM NOT 5 MINUTE INTERVAL
2300 M=MOD(T,100):REM        CALCULATE MINUTES
2310 IF(M=60) GOTO 2100      PREVENTS DOUBLE SAMPLE ON HR
2320 H=(T-M)/100:REM         CALCULATE HOURS
2400 D=(M/60) AND 15 + 10*(I/60) AND 15:REM OBTAIN DATE
2600 N=M/12*M/5+D/100:REM    CALCULATE SAMPLE NUMBER
2620 S=N/16:REM              SECTOR NUMBER
2640 P=MOD(N,16)+32:REM     POINTER TO DATA IN SECTOR
2990 RETURN

3000 REM - GET 10 SAMPLES INTO A ARRAY
3050 A=X1000
3100 FOR I=0 TO 9:REM        10 SAMPLES
3120 OUT(%30,I):REM         SET UP HUX AND START CONV
3140 A(I)=(IN(%30)):REM     READ RESULT
3140 NEXT I

4000 REM - CONVERT SAMPLES TO ASCII FORMAT
4100 FOR I=0 TO 41:REM      FILL BUFFER WITH 42 SPACES
4120 POKE(C,%20):REM       ASCII SPACE
4140 NEXT I
4200 FOR I=0 TO 9:REM       NOW CONV AND MOVE 10 SAMPLES
4240 GEN(C+%4,(A(I)+100)):REM INTO C BUFFER (RANGE:100-155)
4260 NEXT I:REM            FINAL <CR> STILL IN BUFFER
4990 RETURN

5000 REM - MOVE NEW SAMPLES INTO DISK BUFFER AREA IN RAM
5101 FOR I=1 TO 5
5101 DPOKE(B,P+(I-1),DPEEK(C+I))
5102 NEXT I
5103 FOR I=5 TO 7
5104 DPOKE(B,P+(I-2),DPEEK(C+I))
5105 NEXT I
5106 FOR I=9 TO 11
5107 DPOKE(B,P+(I-3),DPEEK(C+I))
5108 NEXT I
5109 FOR I=13 TO 15
5110 DPOKE(B,P+(I-4),DPEEK(C+I))
5111 NEXT I
5112 FOR I=17 TO 19
5113 DPOKE(B,P+(I-5),DPEEK(C+I))
5114 NEXT I

```

```

515 FOR I=21 TO 25
516 DPOKE(B*P+(I-6),DPEEK(C*I))
517 NEXT I
518 FOR I=25 TO 27
519 DPOKE(B*P+(I-7),DPEEK(C*I))
520 NEXT I
521 FOR I=29 TO 31
522 DPOKE(B*P+(I-8),DPEEK(C*I))
523 NEXT I
524 FOR I=33 TO 35
525 DPOKE(B*P+(I-9),DPEEK(C*I))
526 NEXT I
527 FOR I=37 TO 39
528 DPOKE(B*P+(I-10),DPEEK(C*I))
529 NEXT I
530 GEN(B*P+30,M)
5990 RETURN

7000 E = CLOCKRE/D
7010 F = 10*(INP(%E208) AND 15) * INP(%E20A) AND 15
7020 G = 10*(INP(%E209) AND 15) * INP(%E20B) AND 15
7030 Y = 10*(INP(%E20D) AND 15) * INP(%E20C) AND 15
7100 PRINT "8 BIT A/D SIGNAL LEVELS FOR:";E;"I:";F;" /";G;" /";Y
7200 RETURN

8000 FOR I=0 TO 9:REM          SEND DATA TO MONITOR
8010 PRINT "CHANNEL",I+1," DIGITIZED SIGNAL LEVEL:";A(I)*100
8015 PRINT " "
8020 NEXT I
8030 PRINT "-----"
8050 COMINIT(110,C,0,1):REM    INITIALIZE OUTPUT PORT
8055 FOR I = 0 TO 9
8057 Z = A(I)                SEND BINARY DATA OUT OF
8060 Y = COMOUT(Z):REM      PORT 4 (P4) TO THE D.C.P.R.S.
8065 NEXT I
8100 RETURN

9000 REM - INITIALIZATION CODE
9100 U=0:REM                SET OLD TIME TO IMPOSSIBLE VALUE
9120 C=1700:REM             ASCII CONVERSION BUFFER
9140 B=51800:REM           BUFFER FOR DISK DATA
9990 RETURN
32000 STOP

```

APPENDIX B

DATACOPY.COM COMPUTER PROGRAM

```

*****
* PROGRAM TO BE USED ON AN IBM MICRO *
* TO DO AN ABSOLUTE SECTOR READ FROM *
* THE MAGNETIC DISK AND THEN STORE *
* THE DATA IN A DOS FORMAT FILE. *
*****

```

/ DATACOPY PROGRAM

```

I 3 *THRU          / LOAD IN THE PROGRAM CODE
* DO-IT IS BOOT   / SET UP FOR AUTO-RUN
SAVE-SYSTEM B:DATACOPY.COM

```

/ DISK INTERFACE VIA BIOS

```

CODE INT13        (S OFFSET SECTOR# OP -- F )
DI POP AX POP DX DX XOR 720 = BX MOV BX DIV AX PUSH
DX AX MOV DX DX XOR BX SHR BX DIV BX POP AL BM MOV
DX AX MOV 9 = CL MOV CL DIV AH AL XCHG AX INC
AX CX MOV BX DX MOV BX POP DS PUSH ES POP DI AX MOV
AH AL XCHG I = AL MOV SI PUSH BP PUSH IP INT
0 = AX MOV U< IF AX DEC THEN BP POP SI POP IPUSH
END CODE

CODE SETUP        (S BUFFER OP -- OFF1 SEC1 OP OFF2 SEC2 OP )
DX POP BX POP 0 (BX) AX MOV 4 (BX) CX MOV AX SHL
CX PUSH AX PUSH DX PUSH 512 = CX ADD AX INC
CX PUSH AX PUSH DX PUSH NEXT END CODE

: RBIOS 2 SETUP INT13 >R INT13 R> OR DISK-ERROR ! ;
: HBIOS 3 SETUP INT13 >R INT13 R> OR DISK-ERROR ! ;
: BIOS-IO (') RBIOS IS READ-BLOCK (') HBIOS IS WRITE-BLOCK ;
: SET-IO          / SET UP TO READ RAM. WRITE TO DOS
( DOS ) FILE-IO
( FORTH ) (') RBIOS IS READ-BLOCK ;

: DO-COPY         / COPY 31 DAYS WORTH OF DATA
279 0 DO
I 369 * / DATA STARTS ON SECTOR 18 OF DATA DISK
IS EXIT I 5 .R / (THO SECTORS/K, 1K/SCREEN )
I COPY DISK-ERROR 0
KEY? OR IF QUIT THEN LOOP ;

: PROMPT         / WAIT FOR THE USER TO BE READY
." INSERT DATA DISK IN DRIVE B:, DOS DISK IN DRIVE A: " CR
." PRESS ANY KEY WHEN READY. " CR KEY DROP ;

: DO-IT
CR PROMPT        / GET THE DISKS IN PROPERLY
DEFAULT         / OPEN THE OUTPUT FILE
SET-IO          / SET UP TO READ DATA. WRITE TO DOS FILE
DO-COPY         / TRANSFER THE DATA TO THE FILE
CR ." TRANSFER COMPLETE"
BYE            / AND EXIT

```

APPENDIX C

CONVERT FORTRAN COMPUTER PROGRAM

```
C .....
C * THIS PROGRAM WILL CONVERT THE DATA FILE THAT WAS TRANSFERRED *
C * FROM AN IBM PC TO THE MAIN FRAME INTO A NEW FORMAT. THIS *
C * NEW FORMAT WILL ALLOW FOR PLOTTING OF THE DATA USING DISPLA.*
C .....
C
C
C
C THE DATA ARRIVES ON THE MAIN FRAME IN THE FILE 'ACQUIRED DATA'
C FROM THE PCDOS FILE CALLED 'ACQUIRED.DAT' AS APPROXIMATELY 3900
C LINES OF DATA. THE 30 CHARACTER SEGMENTS OF DATA (10 CHANNELS OF
C DATA WITH 3 CHARACTERS PER CHANNEL) ARE WRITTEN INTO THE 80
C CHARACTER PER LINE FILE, SEPARATED BY TWO DIGIT TIME STAMPS (I.E.
C 01,02,03,04, OR 05). THIS PROGRAM READS THE 30 CHARACTER
C SEGMENTS ONE BY ONE OUT OF THE ACQUIRED DATA FILE AND ARRANGES
C THEM IN A SEQUENTIAL FILE. IN THIS WAY THE DATA IS AVAILABLE
C IN AN EASILY DISCERNABLE FORM FOR THE USER AND ALSO IS READILY
C GRAPHED. MINOR ADJUSTMENTS IN THIS PROGRAM MAY BE NECESSARY
C TO ACCOUNT FOR VARIATIONS IN THE MICRO TO MAIN FRAME TRANSFER
C PROCESS. THE POSSIBLE CHANGES ARE NOTED WITHIN THE PROGRAM.
C FOLLOW THE STEPS OUTLINED BELOW TO ARRANGE THE DATA IN A FORMAT
C FOR USE IN A PROGRAM TO GRAPHICALLY DISPLAY THE DATA:
C
C
C
C STEP 1: PUT THE DATA IN THE FILE 'ACQUIRED DATA' INTO A FILE
C CALLED 'FILE FT00P001' AFTER ANY NON ESSENTIAL
C INFORMATION THAT WAS TRANSFERRED HAS BEEN EDITED OUT.
C STEP 2: MAKE ANY NECESSARY CHANGES IN THIS PROGRAM, ESPECIALLY
C TO THE "ISTART" PARAMETER.
C STEP 3: RUN THIS PROGRAM AND SAVE THE NEWLY FORMATTED DATA
C FILE BY ISSUING THE FOLLOWING SEQUENCE OF COMMANDS AT
C THE APPROPRIATE TIMES:
C 'PORTV CONVERT'
C 'RECORD ON'
C 'LOAD CONVERT(START)'
C 'RECORD OFF'
C TEMPORARILY STORE THIS DATA IN ANY FILENAME,FILETYPE.
C STEP 4: ERASE THE FILE CALLED 'FILE FT00P001' CREATED IN STEP 1.
C STEP 5: CHANGE THE NAME OF THE FILE CREATED IN STEP 4 INTO
C 'FILE FT00P001'.
C STEP 6: GO TO THE FILE 'EORFORAP FORTRAN' AND PROCEED.
C .....
```

```

      INTEGER I,J,K,L,ISTART
      CHARACTER*1 A(160),B(32)
C     NOTE: SEE INSTRUCTIONS ON HOW TO SET THIS PARAMETER "ISTART":
      ISTART = 16
      L = 1
5     READ(6,10,END = 1000) A
10    FORMAT(80A1/80A1)
      J=0
      DO 20 I = ISTART+1,32
20    B(I) = A( I - ISTART)
      WRITE(6,30) L,B
30    FORMAT(12,15,1X,30A1)
      L = L + 1
      J = 32 - ISTART
      DO 50 K = 1,4
      DO 40 I = 1,32
40    B(I) = A(I+J)
      WRITE(6,20) L,B
      L = L + 1
50    J = J + 32
      DO 60 I = 1,ISTART
60    B(I) = A(160 - (ISTART + I))
      GO TO 5
1000 CONTINUE
      RETURN
      END

```



```
C   ENTER THE PROPER X AND Y RANGES OF THE GRAPH:
    CALL GRAP (5.50.783.100.20.360)
    CALL GRID(1.1)
    CALL SPLINE
C   ENTER THE ENDING DATA PARAMETER ON THE CHANNEL(S) SELECTED:
C   CHANNEL 1:
    CALL CURVE (T.D0.783.0)
C   CHANNEL 2:
    CALL CURVE (T.D1.783.0)
C   CHANNEL 3:
    CALL CURVE (T.D2.783.0)
C   CHANNEL 4:
    CALL CURVE (T.D3.783.0)
C   CHANNEL 5:
    CALL CURVE (T.D4.783.0)
C   CHANNEL 6:
    CALL CURVE (T.D5.783.0)
C   CHANNEL 7:
    CALL CURVE (T.D6.783.0)
C   CHANNEL 8:
    CALL CURVE (T.D7.783.0)
C   CHANNEL 9:
    CALL CURVE (T.D8.783.0)
C   CHANNEL 10:
    CALL CURVE (T.D9.783.0)
C   CALL ENOPL (0)
    CALL GONEPL
    STOP
    END
```

LIST OF REFERENCES

1. National Academy of Sciences, Earthquake Prediction and Public Policy, pp. 1-34, National Academy of Sciences Printing and Publishing Office, Washington, D.C., 1975.
2. National Research Council Panel on Earthquake Prediction of the Committee on Seismology, Predicting Earthquakes; a Scientific and Technical Evaluation - With Implications for Society, pp. 5-9, National Academy of Sciences Printing and Publishing Office, Washington, D.C., 1976.
3. Whyms, Michael L., Design of a Space Based Sensor to Predict the Intensity and Location of Earthquakes From Electromagnetic Radiation, Master's Thesis, Naval Postgraduate School, Monterey, California, December 1985.
4. Derr, J.S., "Earthquake Lights: A Review of Observations and Present Theories," Bull, Seismological Society of America, v. 63, pp. 2177-2187, 1973.
5. Warwick, J., Stocker, C., and Meyer, T., "Radio Emission Associated With Great Fracture: Possible Application to the Great Chilean Earthquake of May 22, 1960," Journal of Geophysical Research, v. 87, no. B4, April 1982.
6. Ross, M. V., Design of a Freestanding Noise Measurement and Recording System to Predict the Intensity and Location of Electromagnetic Radiation From Earthquakes, Master's Thesis, Naval Postgraduate School, Monterey, California, December 1984.
7. Kasahara, K., Earthquake Mechanics, pp. 194-219, Cambridge University Press, 1981.
8. McCann, W. R., Nishenko, S.P., Sykes, L.R. and Krause, J., "Seismic Gaps and Plate Tectonics: Seismic Potential for Major Boundaries," Earthquake Prediction and Seismicity Patterns, v. 9, pp. 1082-1147, Contributions in Current Research in Geophysics, (CIRES), University of Colorado, Boulder, Colorado, 1979.

9. Rikitake, T., Earthquake Prediction, v. 9 of the Developments in Solid Earth Geophysics Series, Elsevier Scientific Publishing Company, 1976.
10. Adler, R. W., Baycurra, M. and Thompson, D.D., A Shock Wave Theory of Radio Emissions From Earthquake Fault Lines, Paper presented at the Naval Postgraduate School, 1981.
11. U.S. Department of Commerce, National Oceanic and Atmospheric Administration, National Environmental Satellite, Data and Information Service, Technical Memorandum 2; The Geostationary Operational Environmental Satellite Data Collection System, Government Printing Office, Washington, D.C., 1984.
12. U. S. Department of Commerce, National Oceanic and Atmospheric Administration, National Environmental Satellite, Data and Information Service, GOES Data Collection System and Data Processing System User Interface Manual, Government Printing Office, Washington, D.C., 1984.
13. Simware Incorporated, SIMWARE 3278 / PC GUIDE, Third Edition, August 1985.

INITIAL DISTRIBUTION LIST

	No. Copies
1. Defense Technical Information Center Cameron Station Alexandria, Virginia 22304-6145	2
2. Library , Code 0142 Naval Postgraduate School Monterey, California 93943-5002	2
3. Dr. Richard W. Adler Code 62AB Naval Postgraduate School Monterey, California 93943-5000	6
4. Dr. Stephen Jauregui, Jr. Code 62JA Naval Postgraduate School Monterey, CA 93943-5000	1
5. LT. Kevin Ebel 8582 N.W. 27th Dr. Coral Springs, Florida 33065	4
6. Mr. Carl Mortensen MS 977 U.S. Geological Survey 345 Middlefield Menlo Park, California 94025	1
7. ET1 John F. Babka Production Laboratory Bullard Hall Naval Postgraduate School Monterey, CA 93943-5000	2