

AD-A176 612

This Document
Reproduced From
Best Available Copy

R and TARADCOM
LABORATORY
TECHNICAL REPORT

NO. 12415

ABSORBED POWER RIDE MEASUREMENT INSTRUMENT

December, 1978

by RICHARD A. LEE
JAMES CUMBO

~~Approved for public release~~
distribution unlimited.

MMC FILE COPY

**U.S. ARMY TANK-AUTOMOTIVE
RESEARCH AND DEVELOPMENT COMMAND**
Warren, Michigan 48090

SELECTED
FEB 11 1987
A

87 2 10 07

ABSTRACT

An instrument to measure the ride severity of a vehicle has been designed and constructed. The instrument operates on the principle of the passenger/driver's "absorbed power". The theory of absorbed power is covered as well as the limitations of sinusoidal tolerance curves. The complete electronic circuits for the instrument are presented along with its operating instructions.

From 1473

TABLE OF CONTENTS :

	<u>Page No.</u>
Acknowledgements	1
Abstract	11
List of Figures	iv
Objective	v
Introduction	7
Absorbed Power ;	3
Sinusoidal Vibration Limits ;	5
Random Vibration ;	9
Electronic Weighting Circuits ;	11
Operating Instructions ;	20
Circuit Description.	23
References	31
Distribution List	32
Report Documentation Page	33

LIST OF FIGURES

	<u>Page No.</u>
Figure 1, Six watt constant Absorbed Power Curve.	8
Figure 2, Amplitude versus Frequency Graph, Vertical Transfer Function	14
Figure 3, Phase versus Frequency Graph, Vertical Transfer Function	15
Figure 4, Amplitude versus Frequency Graph, Fore-Aft Transfer Function	16
Figure 5, Phase versus Frequency Graph, Fore-Aft Transfer Function	17
Figure 6, Amplitude versus Frequency Graph, Side-to-Side Transfer Function	18
Figure 7, Phase versus Frequency Graph, Side-to-Side Transfer Function	19
Figure 8, Absorbed Power Meter	22
Figure 9, Block Diagram, Absorbed Power Meter	24
Figure 10, Electronic Circuit, Vertical Transfer Function	25
Figure 11, Electronic Circuit, Fore-Aft Transfer Function	26
Figure 12, Electronic Circuit, Side-to-Side Transfer Function	27
Figure 13, Electronic Circuit, Peak Acceleration Detector	28
Figure 14, Electronic Circuit, Multiplier, Divider, Timer	29
Figure 15, Block Diagram, Power Supply	30
Figure 16, Five Volt Power Supply Schematic	30

OBJECTIVE

The objective of this program was to design and construct an instrument to measure vehicle ride. The instrument had to be easy to use, reliable and capable of accurately measuring vehicle ride.

INTRODUCTION

Many different investigators have attempted to quantify vibration severity by subjecting people to different vibrating environments and recording their reactions. The major difficulty encountered is that one is not quantifying a physical phenomenon but human reaction to an external stimulus. This reaction must take the form of a qualitative assessment or it must be relative to some other stimulus; the problems associated with either will be discussed. A method of measuring vibration severity that eliminates the problems of measuring human reaction to vibration will be presented and discussed.

There have been many attempts to attach subjective ratings to vibration severity. These ratings have been described as "intolerable", "annoying", "perceptible", etc. Although there has been a great deal of research done, there has not been universal agreement on what is "annoying" or "intolerable" vibrations. The reason for this is that one cannot attach this type of description to a vibration without defining the environment; in other words, one cannot say that a vibration is "uncomfortable" without first defining the environment the individual is in. A vibration in an automobile may be "annoying", "uncomfortable" or even "intolerable", but this same vibration in a truck may be termed "comfortable". One could ride for hours in his automobile, but if this same vibration were induced in his living room at home, it would be "intolerable". Curves that define reduced comfort boundaries are completely useless to people in the business of designing vehicles unless they are made specifically for that environment. There is also the problem of how to relate frequency spectrums to sinusoidal boundary curves but this problem will be discussed in subsequent sections.

The other method used to evaluate vibration is to rate one vibration or sensual input relative to another. This is called cross-modality and one either related light or sound intensity to a vibration or one vibration is rated relative to another. This method of evaluating the severity of a vibration is at best a very controversial procedure.

Whole body vibration is a completely different phenomenon than a highly localized, or a single sensory input. In whole body vibrations, the sensations that occur in the 4 to 7 cps range are entirely different from the sensations that occur in the 8 to 15 cps range. In the 4 to 7 cps range, the primary objection to the vibration is the resonating, or relative motion, of heart, lungs and other organs located in the thorax. It is

believed that this is caused by the mass above the diaphragm resonating, with the diaphragm acting as a spring. In the 8 to 15 cps, the primary objection is movement of the head. This is also the range of frequencies where loss of visual acuity is most pronounced. It is believed that this is caused by a resonating condition in the spinal column. The major objection in the low frequency range, assuming less than 1g peak, is the relative motion of individual and environment.

It should be understood that the previously mentioned sensations, and an undetermined amount of others, occur simultaneously at all frequencies, but become more pronounced in the frequency range mentioned. Consequently, unless cross-modality measurements made for different sensations give the relation between the measured sensations, then it cannot be used to evaluate whole body vibration. This same problem arises when one attempts to rate one vibration relative to another.

This change of sensation, both in location and sensual input, is primarily frequency sensitive. Therefore, there is some indication that the evaluation of ride may be possible using cross-modality at a single frequency. It is commonly accepted that ride is proportional to some power of acceleration at a single frequency, i.e.,

$$P \propto A^n \quad (1)$$

or:

$$P = KA^n \quad (2)$$

Using cross-modality, it may be possible to solve for the exponent n , and determine if it is frequency sensitive, but at the present it is believed that there are too many unanswered questions to evaluate the frequency dependence of K using cross-modality.

It has been shown from many research experiments that the rate at which the body absorbs energy correlates very well with a person's subjective response or reaction to a vibration. This parameter has been called "absorbed power". It has a physical significance and is measurable. This eliminates the need for measuring human reaction to a vibration, but requires one to measure the absorbed power for a particular vibration environment and one can then easily determine the severity of the vibration. This procedure is analogous to measuring temperature to determine human comfort or discomfort in a particular environment. One does not measure the human reaction but the parameter that affects it.

ABSORBED POWER

The original formulation of absorbed power as a means of measuring vibration severity occurred from observing many different subjects being vibrated in a ride simulator and from the author personally spending many hours being subjected to different vibrations. From this experience two observations were made:

1. The more relative motion occurring between various parts of the body, the more severe the vibration.
2. Doubling the amplitude of the vibration more than doubled the severity.

From these two observations a theory was postulated, "The severity of a vibration is proportional to the rate at which the body is absorbing energy." From this statement an equation can be written that expresses it in mathematical terms:

$$P_{\text{ave}} = \lim_{T \rightarrow \infty} \frac{1}{T} \int_0^T F(t) V(t) dt \quad (3)$$

This calculates the average power absorbed by a human when $F(t)$ is the input force and $V(t)$ is the input velocity. Note for a solid mass $F=ma$ and the average is zero.

Several important observations can be made from this method of evaluating vibration severity.

1. Absorbed power has a physical significance and interpretation. Its variation with different subjects can be measured.
2. It does not rely on sinusoidal limits to determine comfort limits.
3. It gives a single numeric value for a vibration.
4. It can be used for periodic, aperiodic and random vibration.

To validate absorbed power as a means of determining vibration severity, a force-measuring platform was built and several subjects were run through a series of vibration tests. Absorbed power was measured and their subjective responses were recorded. Results of this test were published. Absorbed power correlated extremely well and it was determined that it accurately measured vibration severity. At this point the shape of the sinusoidal tolerance curve was not known.

The equipment required to measure absorbed power was fairly elaborate and it could only realistically be done in the laboratory. The force-measuring platform was large and bulky and required considerable instrumentation for the dynamic measurement of force. What was required was a means to obtain force from an accelerometer. To accomplish this a transfer function was derived that relates force to acceleration. Twenty-one different subjects were sinusoidally vibrated for frequencies of less than one Hz, to over 50 Hz. The force acceleration and phase between them was measured at each frequency. The mean for the 21 subjects was graphed and a transfer function was fit to the graph. This was done for the three linear motions and the feet. These transfer functions were published in an earlier paper and will not be repeated here.

This greatly simplified the calculation of absorbed power and made it possible to calculate it entirely on a computer. However, there was still a problem in the low frequency end of the spectrum. The calculation of absorbed power for low frequency was very dependent upon the phase between force and velocity. Consequently one had to have very high grade amplifiers and integrators to calculate power from an acceleration signal or considerable error would be introduced. The problem was eliminated by deriving a frequency-dependent weight function.

SINUSOIDAL VIBRATION LIMITS

To arrive at a single means to determine the absorbed power from an acceleration signal it was necessary to derive frequency and amplitude weighting functions. The derivations proceeded as follows:

Writing force as a sum of sine waves:

$$F(t) = \sum_{i=0}^n F_i \sin(\omega_i t + \phi_i) \quad (4)$$

and velocity as:

$$V(t) = \sum_{i=0}^n V_i \sin \omega_i t \quad (5)$$

Inserting these expressions into the equation for absorbed power and making appropriate simplifications, the equation for power can be written:

$$P_{ave} = \sum_{i=0}^n F_i V_i \sin \phi_i \left[\lim_{T \rightarrow \infty} \frac{1}{T} \left(\frac{T}{2} + \frac{\sin 2\omega_i T}{4\omega_i} \right) \right] \quad (6)$$

Taking the limits and noting the appropriate substitutions for sinusoidal waves, this reduces to:

$$P_{ave} = \sum_{i=0}^n K_i A_{i,rms}^2 \quad (7)$$

Where K_i is a function of frequency and $A_{i,rms}$ is the root-mean-square of the acceleration.

Absorbed power can then be computed by multiplying the mean-square acceleration of the appropriate K_i .

The derivation of $K_f(W)$ proceeds as follows:

The transfer function that relates force to acceleration can be written as:

$$\frac{F(S)}{A(S)} = G(S) = K_0 \left[\frac{S^n + c_1 S^{n-1} + \dots + c_{n-1} S + c_n}{S^m + c_{n+1} S^{m-1} + \dots + c_{n+m} S + c_{n+m}} \right] \quad (8)$$

Letting $S = JW$ equation (8) can be put into the following form:

$$G(JW) = \frac{K_0(F_1 + JWF_2)}{F_3 + JWF_4} \quad (9)$$

This is simply separating the numerator and denominator into its real and imaginary parts.

The equation for absorbed power can then be written:

$$P_{ave} = \sum_{i=0}^n \left(\frac{|G(W_i)| \cdot A_{1rms}^2}{W_i} \right) \sin \phi_i \quad (10)$$

Then:

$$K_f = \frac{|G(W_i)| \sin \phi_i}{W_i} \quad (11)$$

$G(JW)$ can be manipulated into the following forms:

$$|G(JW)| = K_0 \sqrt{\frac{F_1^2 + W^2 F_2^2}{F_3^2 + W^2 F_4^2}} \quad (12)$$

and:

$$\phi = \tan^{-1} \left[\frac{W(F_2F_3 - F_1F_4)}{F_1F_3 + W^2F_2F_4} \right] \quad (13)$$

Then P ave can be written as:

$$P \text{ ave} = \sum_{i=0}^n K_0 \left[\frac{F_1F_4 - F_2F_3}{F_3^2 + W^2F_4^2} \right] A_{1rms}^2 \quad (14)$$

The F_s are the real and imaginary parts of the transfer function. K_0 is given by:

$$K_1 = K_0 \left[\frac{F_1F_4 - F_2F_3}{F_3^2 + W^2F_4^2} \right] \quad (15)$$

The equations for the F_s were published in reference number one.

If one takes equation (14), sets P ave equal to a constant and solves for the acceleration at each frequency, a constant comfort or tolerance limit curve is obtained. Figure 1 has a 6-watt curve superimposed with the other data to show how it compares with this experimental data. Note, although this 6-watt curve was derived, its correlation with experimental data is very good, giving additional strong evidence that absorbed power accurately measures vibration severity. If one determines a constant power level for a particular vibration environment, this then determines the sinusoidal tolerance limit curve. It is not a curve that is measured but derived.

From past experience 6 watts is about the limit for cross-country type vehicles and .2 to .3 watts for automobiles.

COMPARATIVE HUMAN VIBRATION RESPONSE CURVES

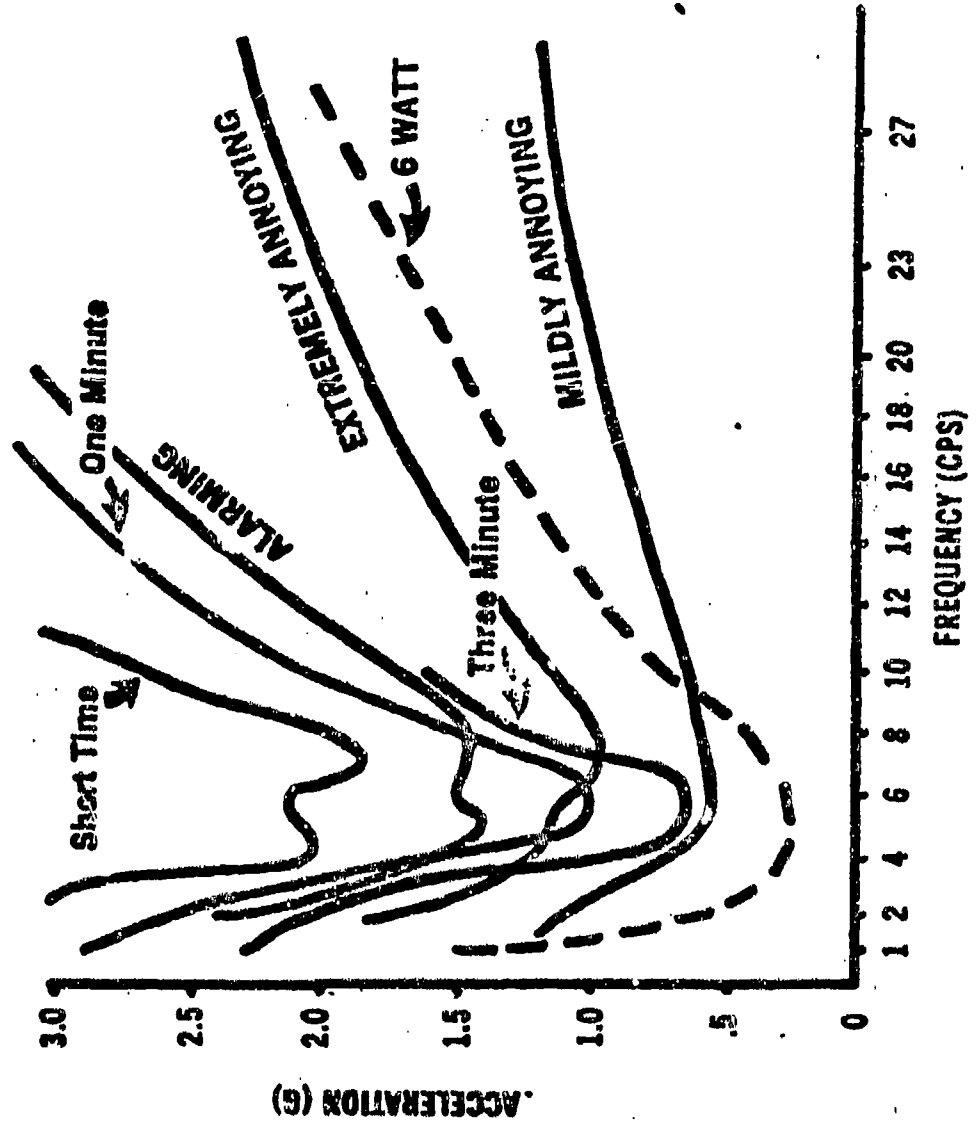

Figure 1

RANDOM VIBRATION

A pure sinusoidal acceleration sine wave is extremely difficult, if not impossible to generate in a mechanical system. This could not be more evident than when one attempts to achieve a sinusoidal vibration in a shaker system. There is always some distortion occurring even though every attempt has been made to achieve a pure or clean sine wave. Thus, a system that attempts to evaluate tolerance limits must be able to evaluate these limits for random or quasi-random type vibrations. If it does not then it proposes a cure for which there is no illness.

To help clarify the situation consider the following example:

If one scans a random vibration with a filter the output from the filter will be given by:

$$e_{rms} = \sqrt{\frac{1}{2\pi} \int_{-\infty}^{\infty} |G(j\omega)|^2 \phi(j\omega) d\omega} \quad (16)$$

$G(j\omega)$ = Transfer function of filter.

$\phi(j\omega)$ = Power spectral density of input signal.

If one now considers an ideal filter, i.e., a filter that has a constant gain over its bandwidth and is everywhere else zero, and uses this filter on a white noise vibration, (white noise has equal amplitude at all frequencies) then inserting these conditions into equation (16) and performing the integration, the output of the filter is given by:

$$e_{rms} = \sqrt{\frac{G^2 K (W_2 - W_1)}{2\pi}} \quad (17)$$

Where G is the gain of the filter, K is the white noise amplitude, and $W_2 - W_1$ is the bandwidth of the filter. Inserting the filter bandwidth into equation (17) it can be written as:

$$e_{rms} = G\sqrt{KB} \quad (18)$$

B = Filter bandwidth

This is a very significant relationship. The output from the filter varies as the square root of the bandwidth. If one scans this signal with a filter that has very narrow bandwidth one would obtain many very low amplitude signals. On the other hand if one opens up the bandwidth, the signal becomes larger. The amplitude can be determined by the filter width. Thus if one applies sinusoidal boundary limits to random vibration, one can obtain any answer he so desires by appropriate choice of filter. Or stated conversely, if one sets filter widths this has as much influence on the final answer as the stated tolerance limits.

Taking equation (18), squaring both sides, and dividing by the bandwidth one obtains:

$$\frac{a_{\text{RMS}}^2}{B} = G^2 K \quad (19)$$

This is power spectral density and is independent of the filter width. There is no ambiguity and the same answer will be obtained independent of the bandwidth of the filter.

It can be shown that the calculation of absorbed power can be written as:

$$P_{\text{ave}} = \frac{1}{2\pi} \int_0^\infty K(\omega) \frac{A^2(\omega)}{B} d\omega \quad (20)$$

Where $K(\omega)$ is the previously derived $K(\omega)$ and $A^2(\omega)/B$ is the acceleration power spectral density.

Thus absorbed power can be calculated in both the time and frequency domain with no introduction of ambiguity or error.

ELECTRONIC WEIGHTING CIRCUITS

To calculate absorbed power from an accelerometer signal it was necessary to formulate an electronic circuit that has gain characteristics that vary with frequency. The output from the circuit must vary as the square of acceleration and have appropriate frequency characteristics to agree with the calculation of absorbed power. The frequency characteristics are determined as follows:

If an acceleration signal is ran through a frequency weighting circuit the output is given by:

$$e_o = G(j\omega)A_{1n} \quad (21)$$

Squaring this output and equating it to power one obtains:

$$[G(j\omega)A_{1n}]^2 = K(\omega)A_{1n}^2 \quad (22)$$

They are identical if:

$$|G(j\omega)| = \sqrt{K(\omega)} \quad (23)$$

or:

$$|G(j\omega)| = \sqrt{\frac{K_0(F_1F_4 - F_2F_3)}{F_3^2 + \omega^2F_4^2}} \quad (24)$$

This then determines the frequency characteristics of the weighting circuit.

The transfer function for each motion was determined by graphing the right-hand side of equation (24) and fitting this curve with a polynomial in S (the Laplace Transform). This determined the frequency characteristics of the electronic weighting circuits.

The solid line in Figure 2 is a graph of the right side of equation (24) for the vertical motion. The value of the F_s and how they were obtained is given in reference 1. The dash line is a graph of the left side of equation (24) to show the correlation achieved. The transfer function for this curve is:

VERTICAL:

$$G(S) = \frac{14.5 S(S + 44)}{(S + 63)(S^2 + 24S + 750)} \quad (25)$$

The solid line in Figure 3 is a graph of the phase angle for the vertical motion. The dash line is a graph of the phase of equation (25).

Figures 4 and 5 are graphs of the amplitudes and phase for Fore-Aft motion. The transfer function is given by:

FORE - AFT:

$$G(S) = \frac{230S}{(S^2 + 16S + 100)(S + 15)} \quad (26)$$

Figures 6 and 7 are amplitude and phase plots for Side-To-Side motion.

SIDE-TO-SIDE:

$$G(S) = \frac{525 S(S + 9.47)(S + 9.8)}{(S^2 + 8.8S + 142)(S^2 + 3.39S + 14.2)(S + 125)} \quad (27)$$

These equations determine the frequency characteristics for the electronic weighting circuits. The output from these must be squared and averaged to obtain the absorbed power for each motion.

The transfer function for each motion was determined by graphing equation (24) and fitting this curve with a polynomial in S. The weighting circuit for each motion was derived in this manner. The equation, circuit and output graph for each motion is given in Figures 2, 3 and 4 and the method of interconnecting these circuits is given in Figure 5. The resultant output is then absorbed power calculated from an accelerometer, weighting, squaring and averaging circuit.

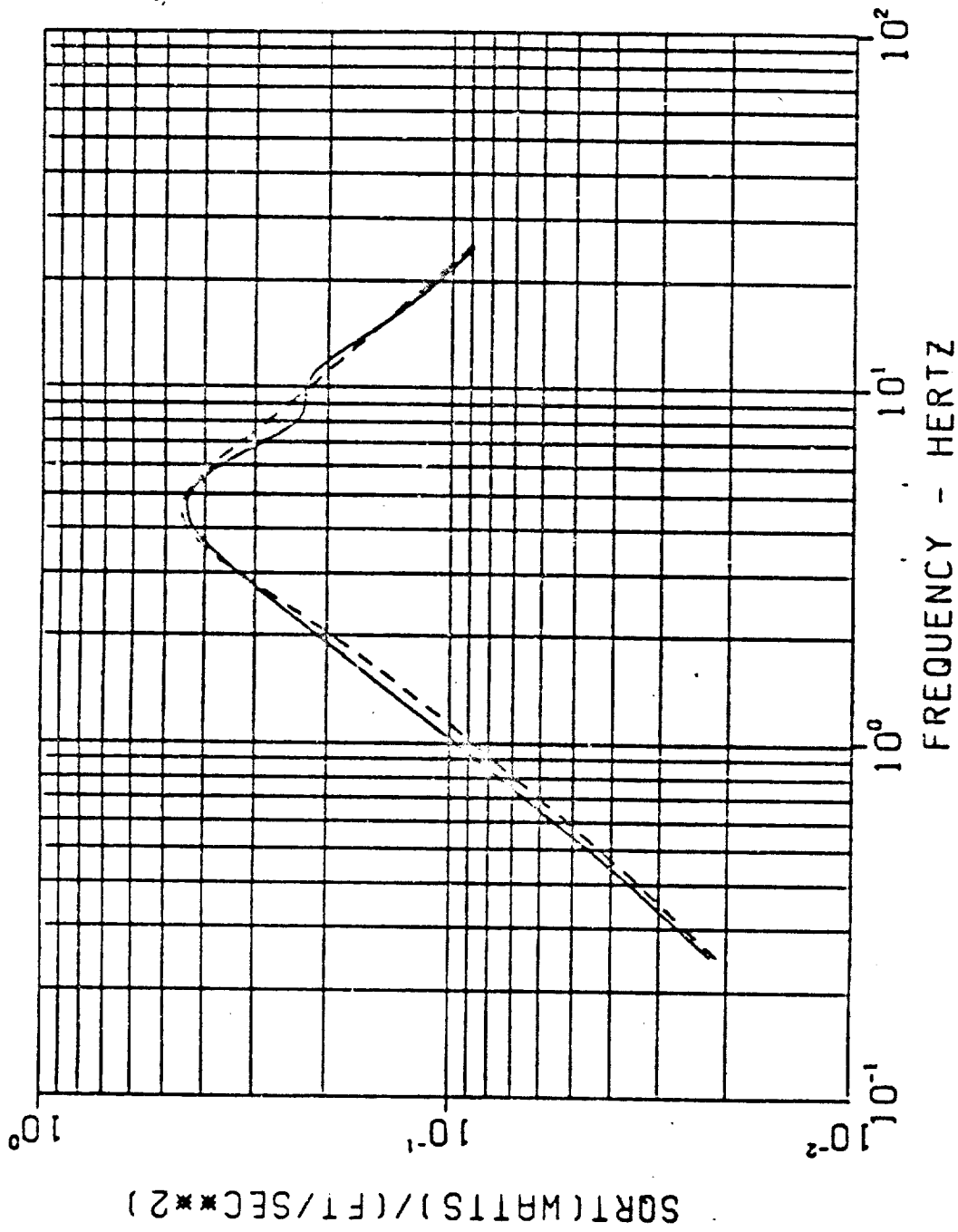

VERTICAL HUMAN RESPONSE CURVE

Figure 2

5/25/78

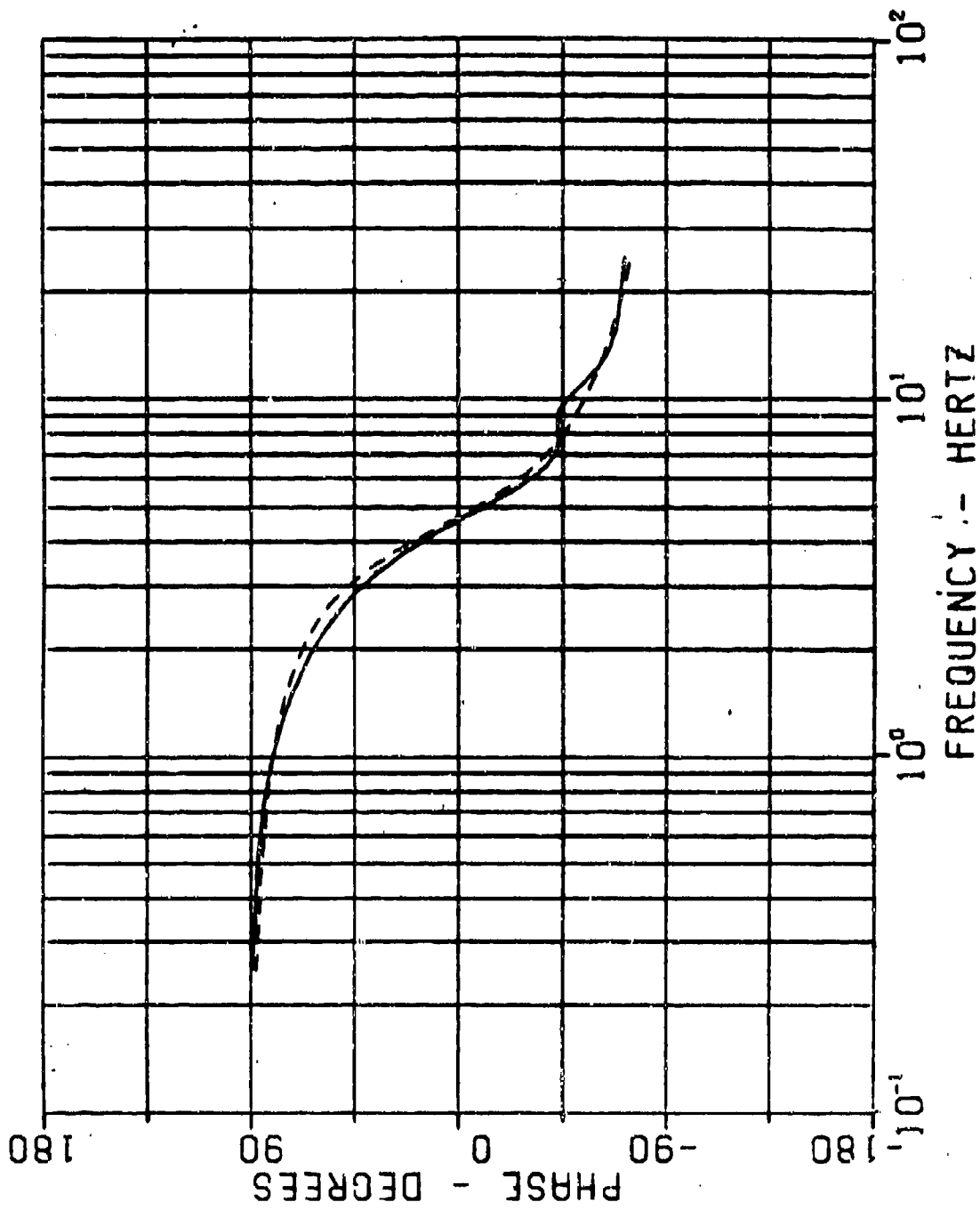

VERTICAL HUMAN RESPONSE CURVE

Figure 3

5/25/78

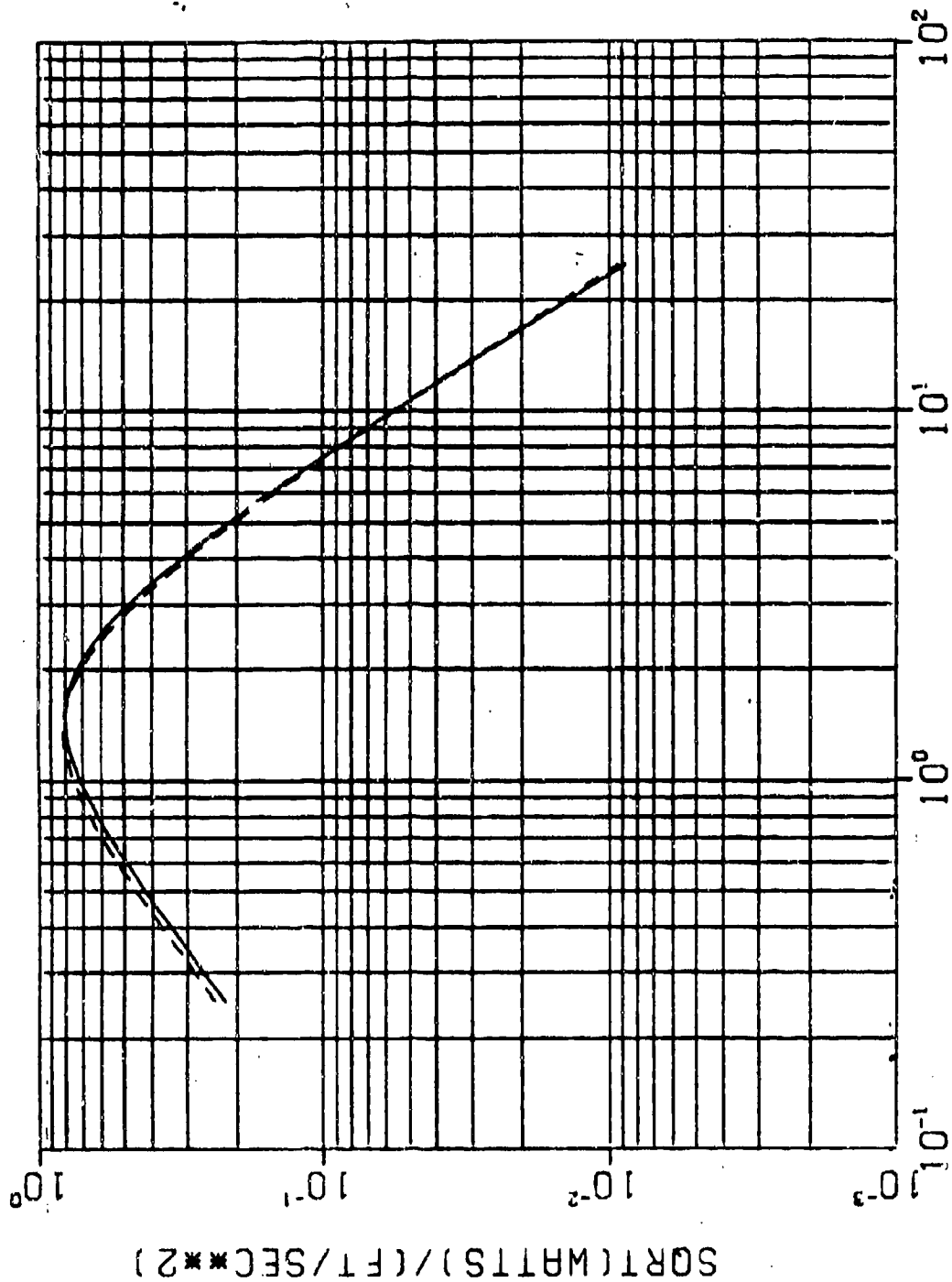

FORE-AFT HUMAN RESPONSE CURVE

Figure 4

5/25/78

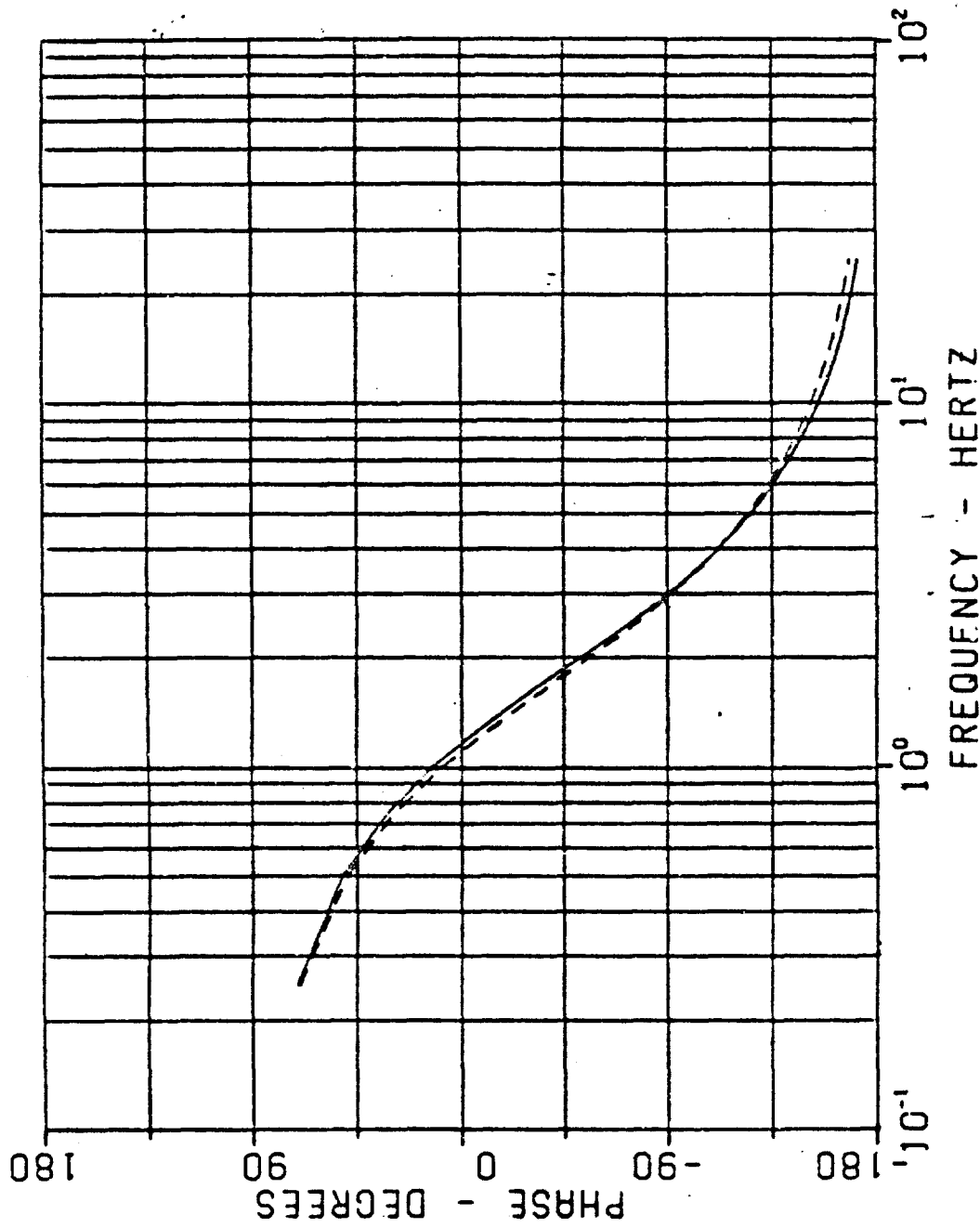

FORE-AFT HUMAN RESPONSE CURVE

Figure 5

5/25/78

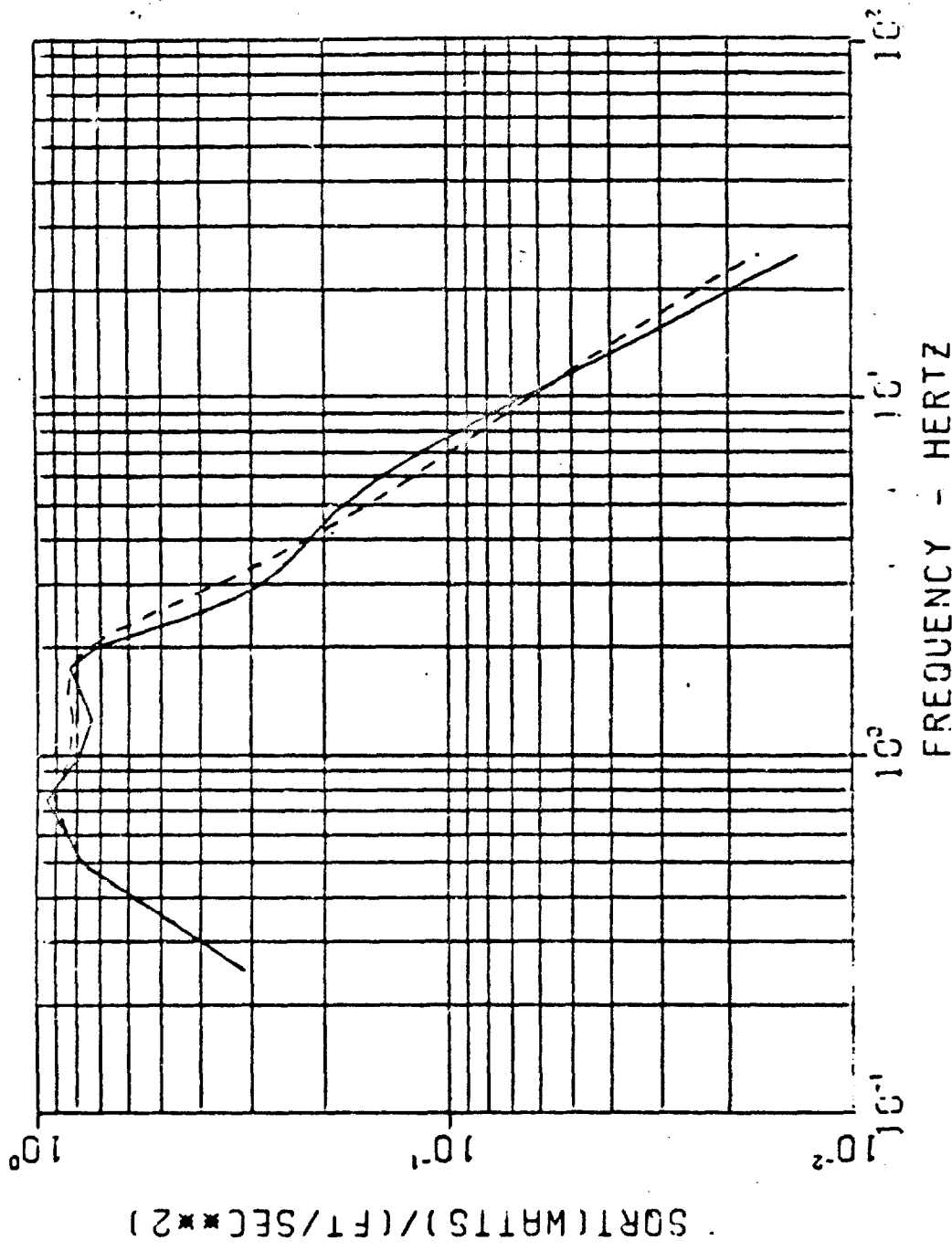

SIDE-TO-SIDE HUMAN RESPONSE CURVE

Figure 6

100000

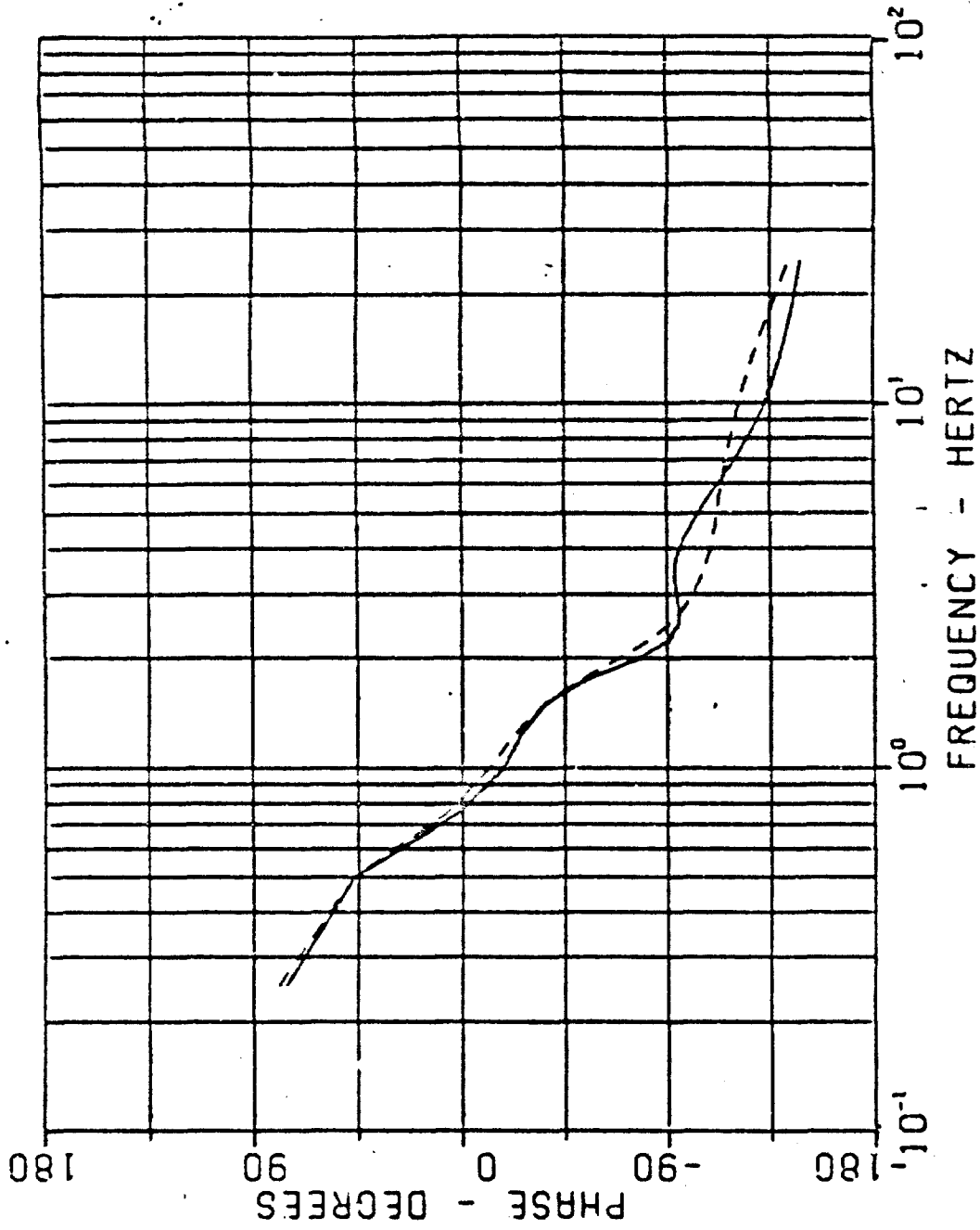

SIDE-TO-SIDE HUMAN RESPONSE CURVE

Figure 7

5/30/78

OPERATING INSTRUCTIONS

Operation of the Absorbed Power Ride evaluation unit is simple. The operating controls consist of four switches. Refer to Figure 8 for location.

1. Three position toggle switch for "Mode" control to select Operate, Hold or Reset conditions for the unit.

In the "Operate" mode the unit is computing and storing the average Absorbed Power for the Vertical, Side-Side and Fore-Aft motions. (not to exceed 200 sec).

In the "Hold" mode the unit retains the readings obtained while in "Operate" thus permitting the operator to readout the three power readings on the digital display by rotating the readout selector switch to the desired position.

In the "Reset" mode the storage devices are returned to zero and the unit is ready for the next run.

2. Three position rotary switch for selecting the Vertical, Side-Side and Fore-Aft power reading to be displayed on the digital readout.

3. Three position rotary "Acceleration Range" control switch to select preset peak acceleration levels to be monitored by the acceleration indicator. The indicator is lit and remains so when the preset level is reached or exceeded during a run.

4. Momentary contact push button "Reset" switch to reset the peak acceleration indicator light.

To use the instrument mount the triaxial accelerometer to the vehicle at the station to be tested. (Driver's, gunner's, cargo area, etc) and proceed as follows.

For Absorbed Power readings the operating procedure is -

a. Bring the vehicle to desired speed and put the "Mode" control switch in the "Operate" position (up). Runs are not to exceed 200 seconds.

b. When the course has been covered, put the "Mode" control switch in the "Hold" position (center).

c. Rotate the "Readout Selector" switch to the Vertical, Side-Side and Fore-Aft positions and record the readings.

d. Move the "Mode" control switch to the "Reset" position (down) to prepare unit for the next run.

For Peak Acceleration detection the operating procedure is -

a. Preset the peak acceleration range switch to the level to be detected.

b. Proceed with the run as in step "A" of the Absorbed Power procedure.

c. If the indicator light comes on, the preset level has been reached or exceeded.

d. To reset the level detector, push the "Reset" button.

e. You are now ready for the next run.

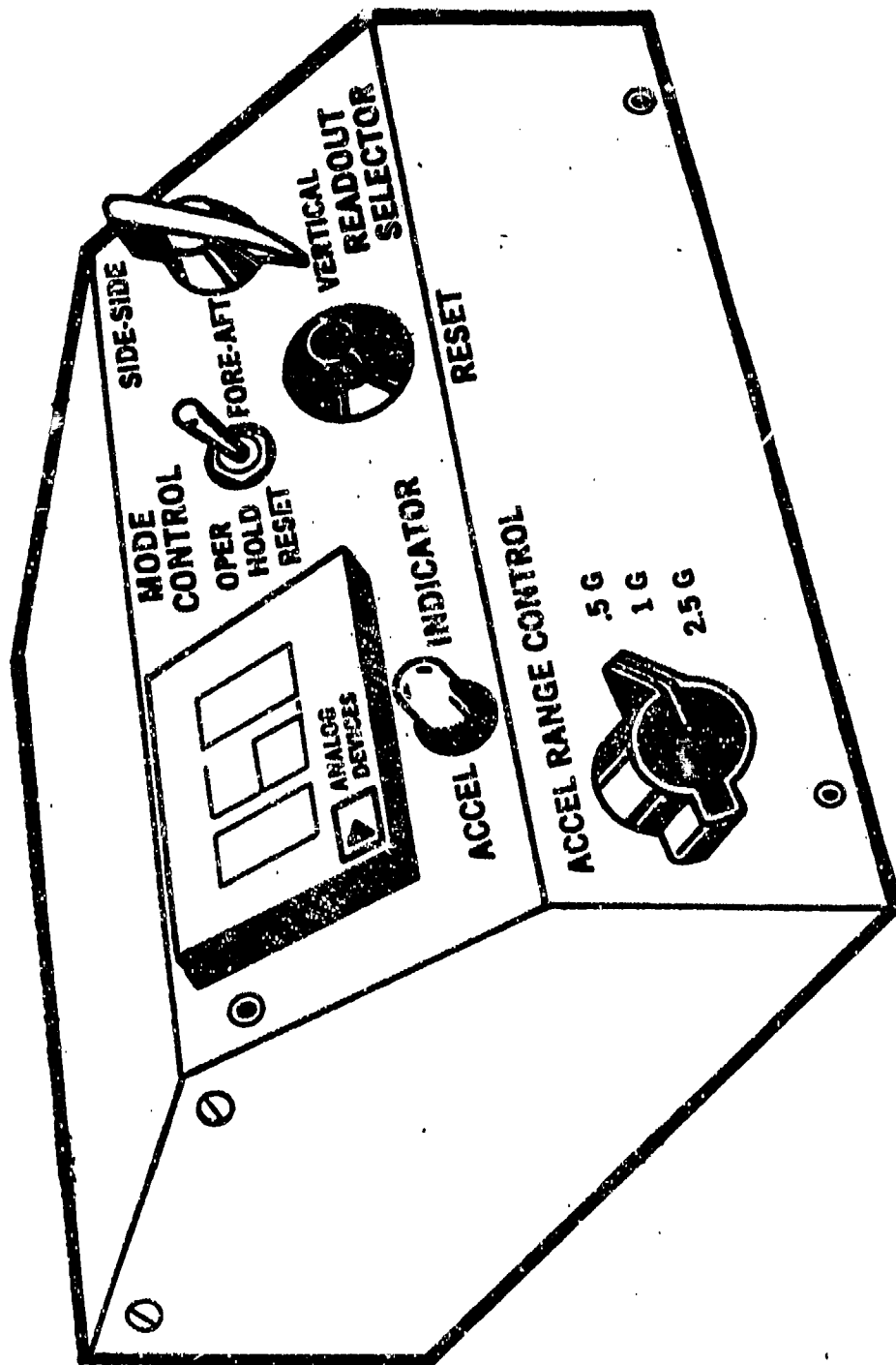

ABSORBED POWER METER

Figure 8

CIRCUIT DESCRIPTION

Figure 9 is a block diagram showing the interconnection of the various circuits. The acceleration is obtained from a triaxial accelerometer. (If only one motion is desired a single accelerometer can be used). The accelerations are fed through the frequency weighting circuits. Each motion has its own squaring and storage circuit. The frequency weighting circuits for each motion are given in Figures 10, 11 and 12. The circuit for the peak acceleration detector is given in Figure 13. This circuit is used to determine the peak acceleration input. The level is set by the acceleration range knob. When an acceleration exceeds the set level, the light will light and remain on until reset.

Figure 14 shows the prior connections for the chips used for the multiplier and divider. Each motion has its own multiplier and divider. The output from the multiplier (squaring circuit) is integrated and the output from the integrator is fed into the divider circuit. This signal is divided by time in the divider circuit. Time is achieved by feeding a reference voltage into an integrator. The output from the timing circuit is used in the three divider circuits. The output from these circuits is displayed on the meter with the desired reading obtained by the selector switch.

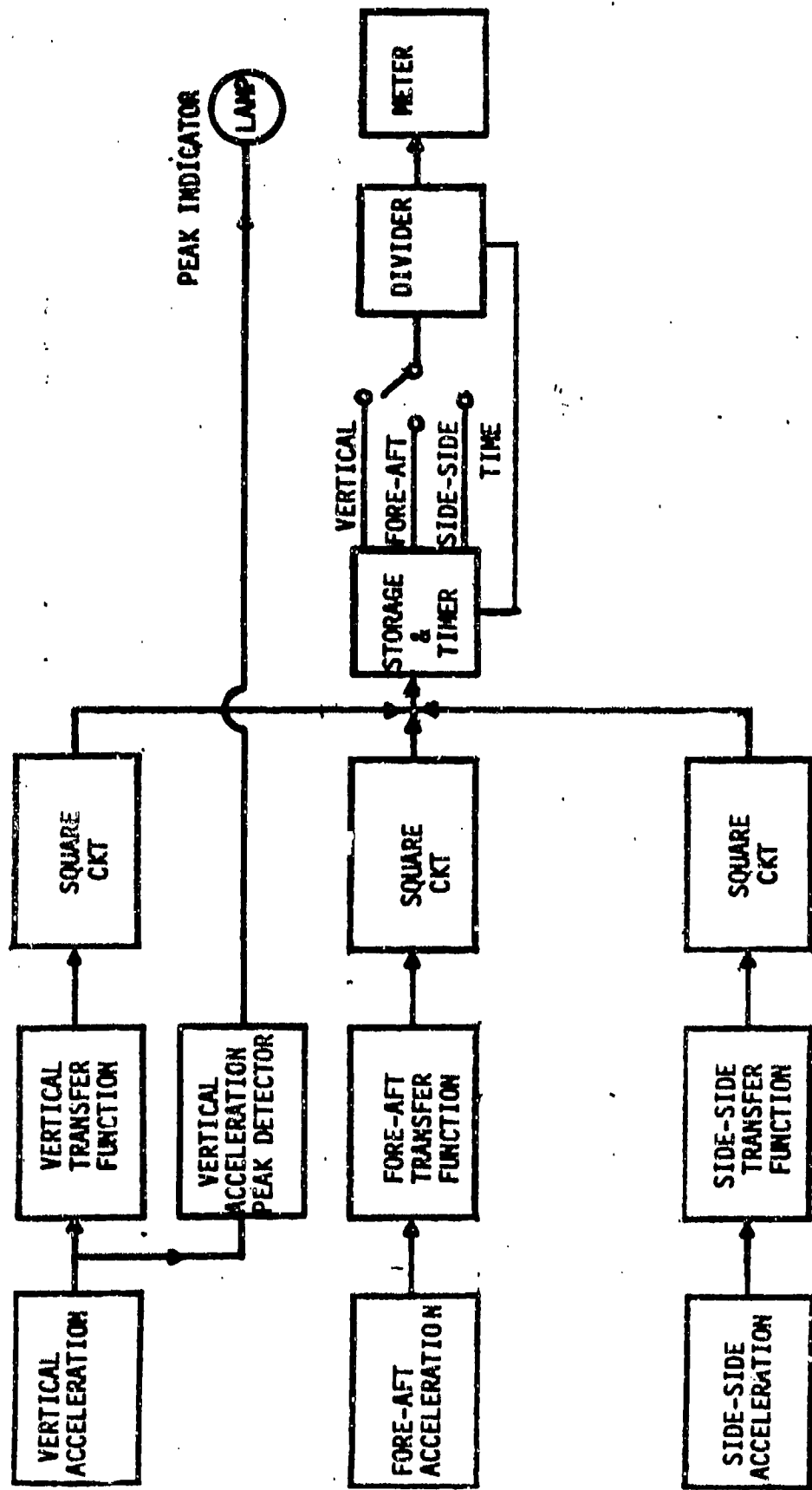

ABSORBED POWER COMPUTING PROCESS

Block Diagram
Simplified Absorbed
Power Ckt

Figure 9

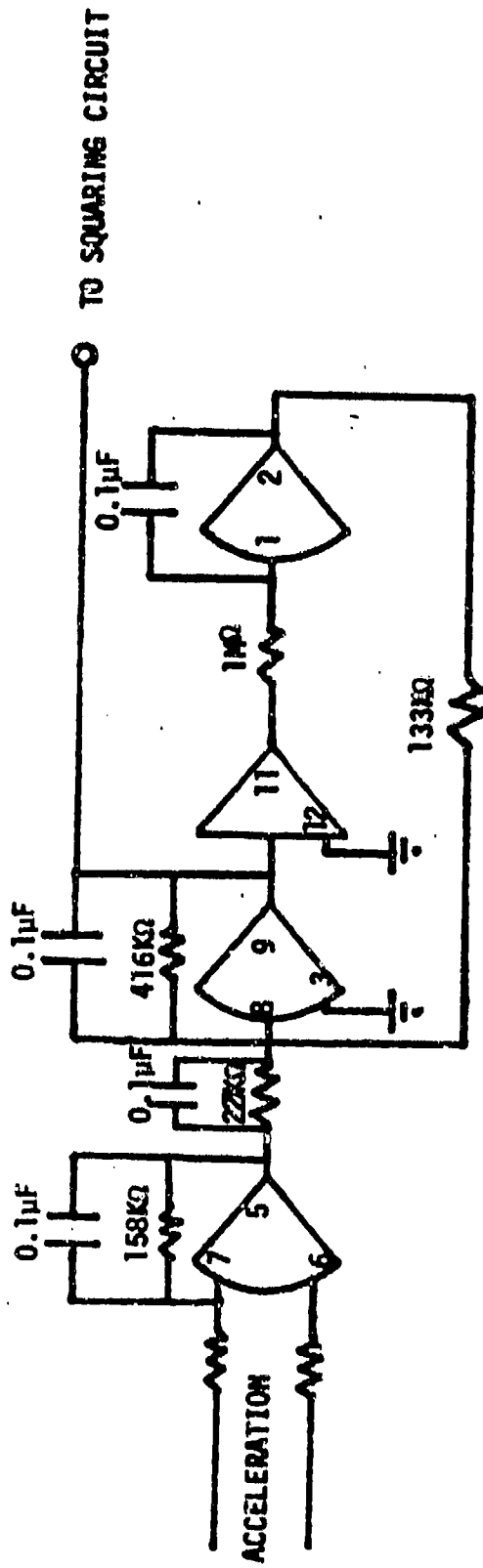

UAF 31 BURR-BROWN
 4 = +15VDC
 10 = -15VDC

$$\frac{\text{Output}}{\text{Input}} = \frac{14.5S(S + 44)}{(S + 63)(S^2 + 245 + 750)}$$

VERTICAL CIRCUIT DIAGRAM

Figure 10

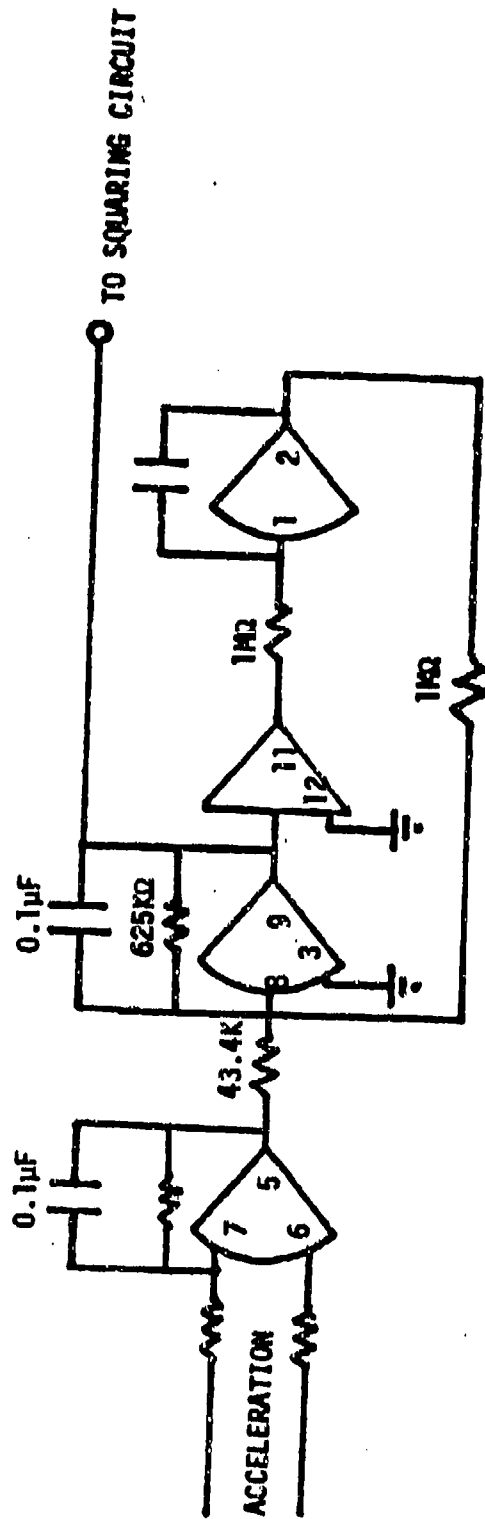

$$\frac{\text{Output}}{\text{Input}} = \frac{230 S}{(S^2 + 16S + 100)(S + 15)}$$

UAF 31 BURRO-BROWN
 PIN4 = +15VDC
 PIN10 = -15VDC

FORE-AFT CIRCUIT DIAGRAM

Figure 11

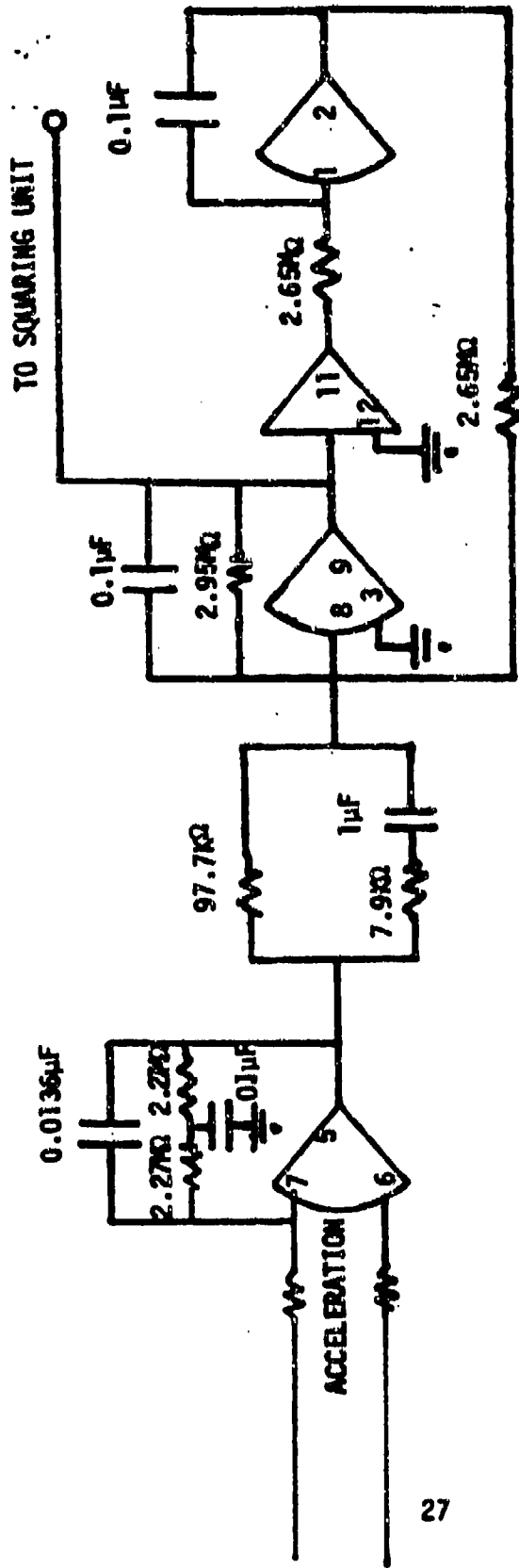

$$\frac{\text{Output}}{\text{Input}} = \frac{(525) S(S + 9.47)(S + 6.8)}{(S^2 + 8.8S + 142)(S^2 + 3.39S + 14.2)(S + 126)}$$

UAF 31 BURR-BROWN

4 = +15VDC

10 = -15VDC

SIDE-SIDE CIRCUIT DIAGRAM

Figure 12

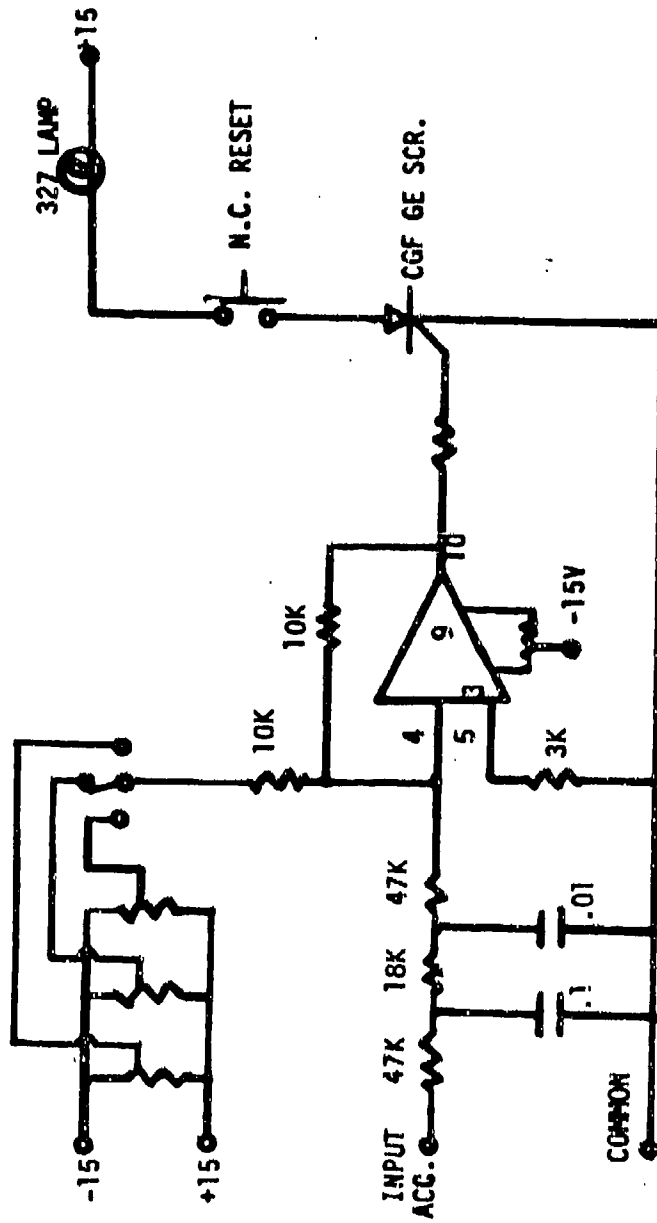

ACCELERATION PEAK DETECTOR

Figure 13

ABSORBED POWER COMPUTING PROCESS CIRCUIT DIAGRAM

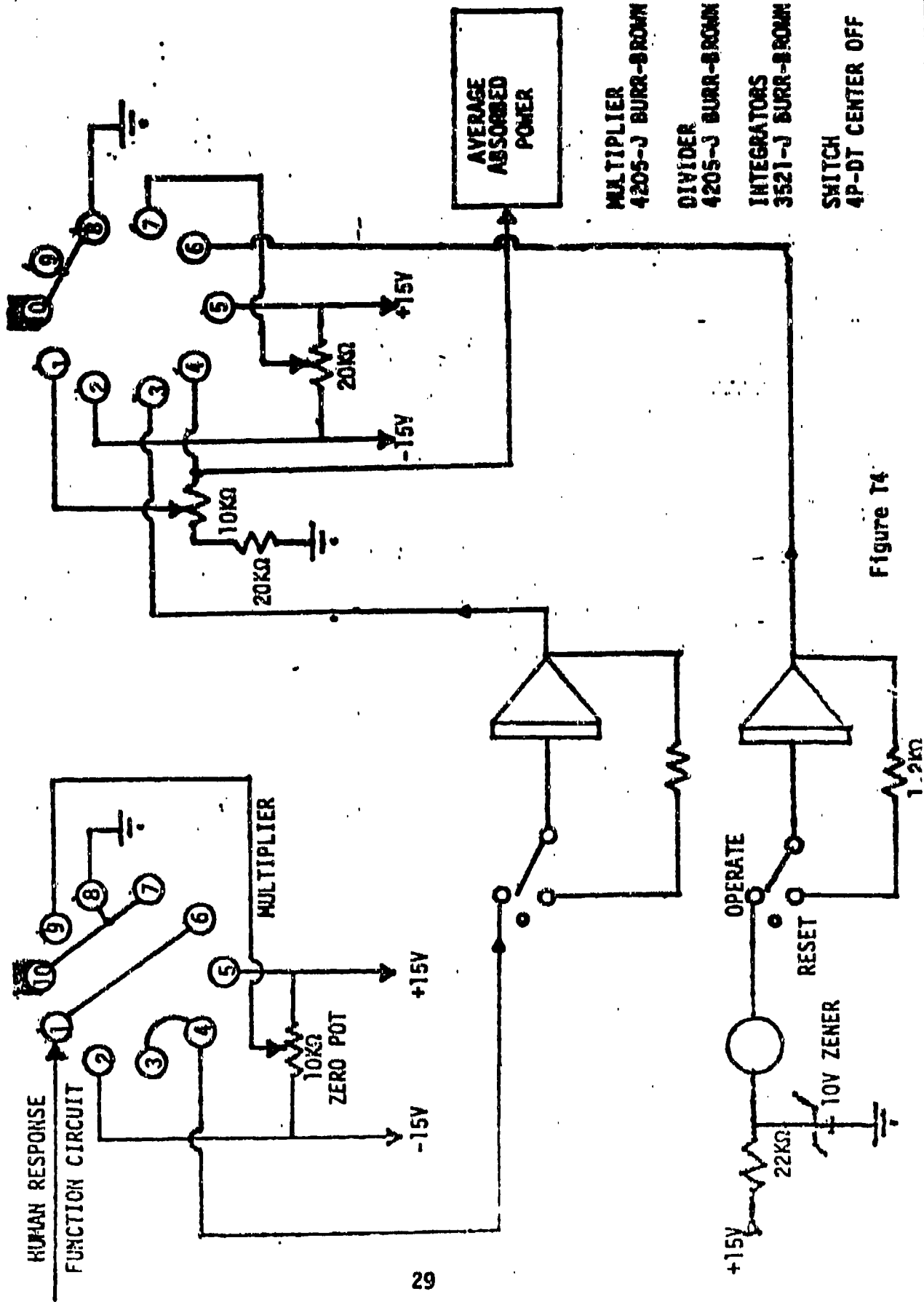

Figure 14

Power required for the "Absorbed Power Ride Evaluation Unit" is +5VDC and ± 15 VDC. They are obtained by means of a series regulator to drop the source voltage to 5 VDC and a Burr-Brown #546 power module that converts +5 VDC to ± 15 VDC.

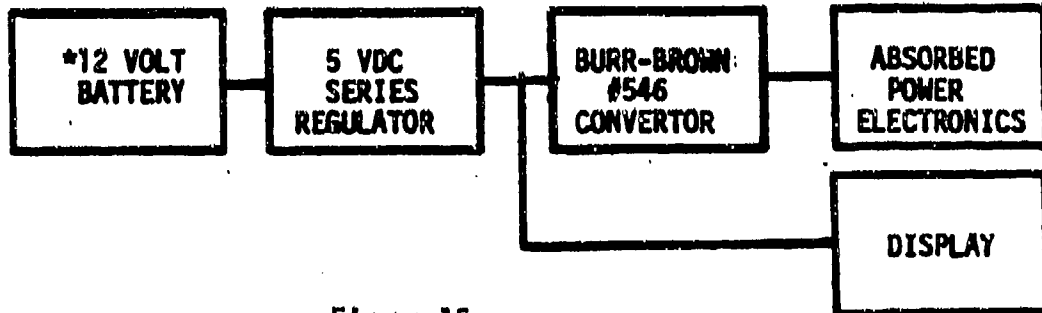

Figure 15

* can be 24 VDC source by changing value of R_1 or wattage rating of Z_1 .

The source to +5 VDC convertor is a simple solid state device utilizing a NPN transistor and zener diode in a series regulator configuration.

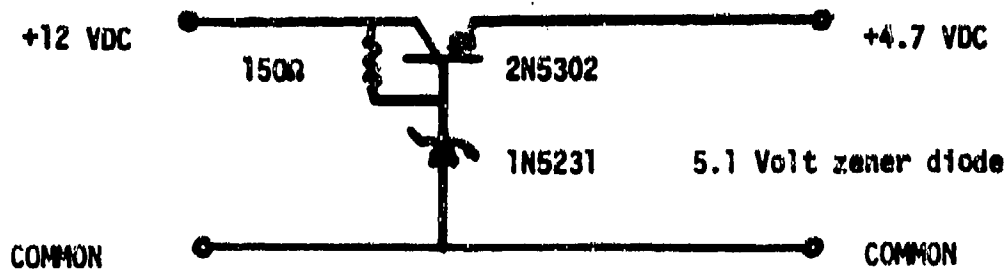

Figure 16

The 5.1 volt zener was selected to give a +4.7 VDC output to prolong the life of the AD-2002 digital readout device.

References

1. Lee, R. A. and Pradko, F., Analytical Analysis of Human Vibration, Society of Automotive Engineers, June 1968, 680091
2. Pradko, F. and Lee, R. A., Theory of Human Vibration Response, American Society of Mechanical Engineers, September 1967, 66-WA/DHF-15
3. Pradko, F. and Lee, R. A., Vibration Comfort Criteria, Society of Automotive Engineers, January 1966, 660139
4. Lee, R. A. and King, A. I., Visual Vibration Response, American Society of Mechanical Engineers, June 1970

DISTRIBUTION LIST

No. of Copies

Commander
U.S. Army Tank-Automotive Research and
Development Command
Warren, MI 48090

ATTN:

Chief Scientist, DRDTA-NS	1
Director, Tank-Automotive Systems Laboratories, DRDTA-R	1
Director, Tank-Automotive Concepts Laboratories, DRDTA-Z	1
Track and Suspension Function, DRDTA-RKT Computer Simulation and Test Methodology, DRDTA-RRS	2
Administrative Office, DRDTA-UA	10
Systems Analysis Division, DRDTA-VS	1
Technical Support Division, DRDTA-TTS	6

U.S. Army Material Systems Analysis Activity
ATTN: DRXSY-MP
Aberdeen Proving Ground, MD 21005

Defense Documentation Center
Cameron Station
Alexandria, VA 22314

2

2

UNCLASSIFIED

SECURITY CLASSIFICATION OF THIS PAGE (When Data Entered)

REPORT DOCUMENTATION PAGE		READ INSTRUCTIONS BEFORE COMPLETING FORM
1. REPORT NUMBER 12415	2. GOVT ACCESSION NO. ADA176612	3. RECIPIENT'S CATALOG NUMBER
4. TITLE (and Subtitle) ABSORBED POWER RIDE MEASUREMENT INSTRUMENT		5. TYPE OF REPORT & PERIOD COVERED
7. AUTHOR(s) RICHARD A. LEE JAMES CUMBOW		6. PERFORMING ORG. REPORT NUMBER
8. PERFORMING ORGANIZATION NAME AND ADDRESS Comp Sim & Test Meth, CROVA-RRS Warren, MI 48090		9. CONTRACT OR GRANT NUMBER(s)
11. CONTROLLING OFFICE NAME AND ADDRESS TARADCOM Warren, MI 48090		10. PROGRAM ELEMENT, PROJECT, TASK AREA & WORK UNIT NUMBERS
14. MONITORING AGENCY NAME & ADDRESS (if different from Controlling Office)		12. REPORT DATE Dec 1977
		13. NUMBER OF PAGES 38
		15. SECURITY CLASS. (of this report) UNCLASSIFIED
		16a. DECLASSIFICATION/DOWNGRADING SCHEDULE
16. DISTRIBUTION STATEMENT (of this Report) Approved for public release, distribution unlimited.		
17. DISTRIBUTION STATEMENT (of the abstract entered in Block 20, if different from Report)		
18. SUPPLEMENTARY NOTES		
19. KEY WORDS (Continue on reverse side if necessary and identify by block number) Absorbed Power Ride Vibration		
20. ABSTRACT (Continue on reverse side if necessary and identify by block number) An instrument to measure the ride severity of a vehicle has been designed and constructed. The instrument operates on the principle of the passenger/driver's "absorbed power". The theory of absorbed power is covered as well as the limitations of sinusoidal tolerance curves. The complete electronic circuits for the instrument are presented along with its operating instructions. top. iii 4		

SECURITY CLASSIFICATION OF THIS PAGE(When Data Entered)

BEST AVAILABLE COPY

SECURITY CLASSIFICATION OF THIS PAGE(When Data Entered)