

AD-A176 635

POLARIZATION PULSE COMPRESSION AND GROUP COMPLEMENTARY
CODES (U) ARMY MISSILE COMMAND REDSTONE ARSENAL AL
ADVANCED SENSORS DIR. E M HOLLIDAY AUG 86
AMSMI/TR-RD-AS-86-6 SBI-AD-E950 894

1/1

UNCLASSIFIED

F/G 12/3

NL

END
DATE
FILMED
7 87

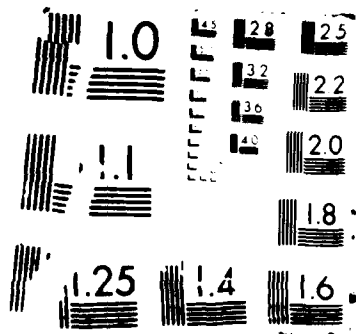

950 894

②

AD-A176 635



TECHNICAL REPORT RD-AS-86-6

POLARIZATION PULSE COMPRESSION
AND GROUP COMPLEMENTARY CODES

E. M. Holliday
Advanced Sensors Directorate
Research, Development, and Engineering Center

AUGUST 1986

DTIC
ELECTE
FEB 3 1987
A



U.S. ARMY MISSILE COMMAND

Redstone Arsenal, Alabama 35898-5000

Approved for public release; distribution is unlimited.

MMC FILE COPY

87 2 2 072

REPORT DOCUMENTATION PAGE				Form Approved OMB No 0704 0188 Exp Date Jun 30 1986	
1a REPORT SECURITY CLASSIFICATION UNCLASSIFIED		1b RESTRICTIVE MARKINGS			
2a SECURITY CLASSIFICATION AUTHORITY		3 DISTRIBUTION/AVAILABILITY OF REPORT			
2b DECLASSIFICATION/DOWNGRADING SCHEDULE		Approved for public release; distribution is unlimited.			
4 PERFORMING ORGANIZATION REPORT NUMBER(S) RD-AS-86-6		5 MONITORING ORGANIZATION REPORT NUMBER(S)			
6a NAME OF PERFORMING ORGANIZATION Advanced Sensors Directorate		6b OFFICE SYMBOL (If applicable) AMSMI-RD-AS-RF	7a NAME OF MONITORING ORGANIZATION		
6c ADDRESS (City, State, and ZIP Code) Commander U. S. Army Missile Command ATTN: AMSMI-RD-AS-RF Redstone Arsenal, AL 35898-5253		7b ADDRESS (City, State, and ZIP Code)			
8a. NAME OF FUNDING/SPONSORING ORGANIZATION		8b OFFICE SYMBOL (If applicable)	9 PROCUREMENT INSTRUMENT IDENTIFICATION NUMBER		
8c. ADDRESS (City, State, and ZIP Code)		10 SOURCE OF FUNDING NUMBERS			
		PROGRAM ELEMENT NO	PROJECT NO	TASK NO	WORK UNIT ACCESSION NO
11 TITLE (Include Security Classification) POLARIZATION PULSE COMPRESSION AND GROUP COMPLEMENTARY CODES					
12. PERSONAL AUTHOR(S) E. M. Holliday					
13a TYPE OF REPORT Final		13b TIME COVERED FROM Oct 85 TO Nov 85		14 DATE OF REPORT (Year, Month, Day) August 1986	15 PAGE COUNT 16
16. SUPPLEMENTARY NOTATION					
17 COSATI CODES			18 SUBJECT TERMS (Continue on reverse if necessary and identify by block number)		
FIELD	GROUP	SUB-GROUP	Pulse compression Golary code pairs		
			Group Complementary Codes		
		<i>Barker</i>	Baker Codes		
19. ABSTRACT (Continue on reverse if necessary and identify by block number)					
<p>Doppler insensitive pulse compression may be achieved through intrapulse coding of the radiated polarization. By controlling the phase relationship between two transmit/receive channels, right hand or left hand circular polarization may be switched back and forth within the transmitted pulse according to a binary code. Such an approach will be enhanced in performance through the use of Group Complementary Coding which has the attribute of having zero time sidelobes. This report presents the above described method of pulse compression.</p>					
20 DISTRIBUTION/AVAILABILITY OF ABSTRACT <input checked="" type="checkbox"/> UNCLASSIFIED/DUNLIMITED <input type="checkbox"/> SAME AS RPT <input type="checkbox"/> DTIC USERS			21 ABSTRACT SECURITY CLASSIFICATION UNCLASSIFIED		
22a NAME OF RESPONSIBLE INDIVIDUAL E. M. Holliday			22b TELEPHONE (Include Area Code) (205) 876-3318	22c OFFICE SYMBOL AMSMI-RD-AS-RF	

TABLE OF CONTENTS

	<u>Page</u>
I. INTRODUCTION	1
II. POLARIZATION PULSE COMPRESSION	2
III. GROUP COMPLEMENTARY CODES	5
IV. COMBINING GROUP COMPLEMENTARY CODES WITH POLARIZATION MODULATION	7
V. SUMMARY	10
DISTRIBUTION	Dist-1



Accession For	
BTIS GRA&I	<input checked="" type="checkbox"/>
DTIC TAB	<input type="checkbox"/>
Unannounced	<input type="checkbox"/>
Justification	
By _____	
Distribution/	
Availability Codes	
Dist	Avail and/or Special
A-1	

PREFACE

The purpose of this report is to document a presentation prepared by the author for delivery by the Deputy Director, Advanced Sensors Directorate Research, Development, and Engineering Center, U.S. Army Missile Command, to the Twenty Eighth Meeting of the Technical Cooperation Program Subgroup-K held in London, England.

I. INTRODUCTION

The technique of pulse compression involves the rearrangement of the temporal distribution of energy in a pulse in such a way that a long pulse with a given energy is transformed to a shorter pulse with the same energy. The instantaneous power during the shortened pulse is; therefore greater than the instantaneous power during the long pulse, since the total energy is the same for both. One reason pulse compression is useful in target sensor systems is it allows a more precise measurement of a waveform arrival time thereby providing greater accuracy to target distance. If the active sensor is peak power limited, as is usually the case, pulse compression allows long-pulse, limited peak power systems to have performance equivalent to a shorter-pulse higher-peak power system.

Ideally, pulse compression is implemented with matched filters where the processing device is a network with impulse response matched to the time reverse of the long-pulse waveform. This matched-filter operation results in maximizing the signal-to-noise ratio and in optimum detection of the target.

Pulse-compression techniques can be implemented using trasveral filtering. Essentially, the method is to delay the energy arriving early in the long-pulse period, add it coherently with the energy that arrives later in the pulse, and output the resulting shorter pulse. Two technical issues that arise in the evaluation of the effectiveness of the pulse-compression systems are sidelobes in the compressed-pulse waveform and the response of the transversed filter to other, nonmatched waveforms which may be present in the received signal. The non-matched waveforms could be the result of receiving the transmission of other deployed sensors or the result of the transmissions of intentional jammers.

An array of waveforms has been used for pulse compression, including binary coding of the phase of a carrier signal (bi-phase modulation using binary codes). Perhaps the best-known codes for use in bi-phase modulation implementations of pulse compression are the Barker Codes. Other binary waveforms that have been used for pulse compression include pseudo-random codes and random binary codes. Nonbinary waveforms that have been used for pulse compression include FM modulated signals and polyphase codes.

A problem that has limited the utility of pulse compression and correlation receivers in radar systems has been the existence of temporal/range sidelobes in the correlation function of the radar waveform. These sidelobes allow out-of-range-gate returns, such as clutter, to compete with a target in a particular range gate. A number of research efforts have addressed this problem in the past, and several waveform designs have resulted in the potential reduction or elimination of the range sidelobe problem. For example, Barker codes (also know as perfect binary words) limit the range sidelobes. Barker codes are known for lengths only up to $N=13$, and they do not match the desired "perfect" range cbrelation property.

Application of Golay code pairs (also known as compelmentary sequences) involves processing two coded pulses at a time in a radar processor to eliminate the range sidelobes. These codes have the property that when their individual range sidelobes are combined (algebraic addition), the composite

sidelobes completely cancel, yielding the desired perfect correlation property. Complementary sequences are known to exist for a limited number of sequence lengths, including $N=2, 4, 8, 10, 16, 20, 32$ and 40 .

Several properties of binary code waveforms are desirable if they are to be used in implementing pulse compression in the target sensor component of a missile or fire-control system. These include very low or zero temporal sidelobes in the autocorrelation function and very low or zero cross-correlation with other binary codes that may be implemented in sensors deployed nearby. These properties would ensure that there would be little or no degradation in sensor system performance due to out-of-range clutter returns, multiple target sidelobes, or mutual interference between deployed sensors using different codes.

Long binary codes with the desired properties are required in order to implement waveforms with large time bandwidth products and large pulse-width compression ratios. This report describes the structure and properties of such a waveform, called Group Complementary Codes along with a new pulse compression scheme.

A new technique for pulse compression has been revealed (Patent #359646) which utilizes the polarization of the expanded and radiated signal as the vehicle of coding to achieve compression of the received pulse. This is a unique approach which offers a doppler insensitive waveform, avoiding the mismatch losses suffered in typical pulse compression methods.

Most pulse expansion/compression techniques result with undesirable time/sidelobe responses which require amplitude weighting to achieve acceptable sidelobes. A pulse encoding and processing technique has been developed (Patent #4513288) to achieve zero time sidelobes, this approach being called Group Complementary Coding. The combination of Group Complementary Coding and polarization pulse compression is expected to offer enhanced exploitation of target and clutter polarization characteristics for discrimination between the two.

This report presents definition of the two techniques and addresses combining the two for the benefit of doppler insensitive pulse compression with zero time sidelobe responses.

II. POLARIZATION PULSE COMPRESSION

Under research at Georgia Institute of Technology (Ga. Tech) sponsored by the Office of Naval Research, and the U.S. Army Missile Command (MICOM) a new pulse compression scheme has surfaced. This being the process of achieving pulse compression while operating upon the polarization of the radiated transmission. Figure 1 presents the basic approach which uses the transmitted and received polarization as the information carrier to achieve pulse compression. By establishing two channels (transmit and receive each) and controlling the relative phase between the two transmitting channels a circularly polarized wave of either right/left hand sense can be generated within the envelope of the pulse. Thus, a sequence of polarization switching will occur within the transmitted pulse and an even reflector will return the same sequence while an

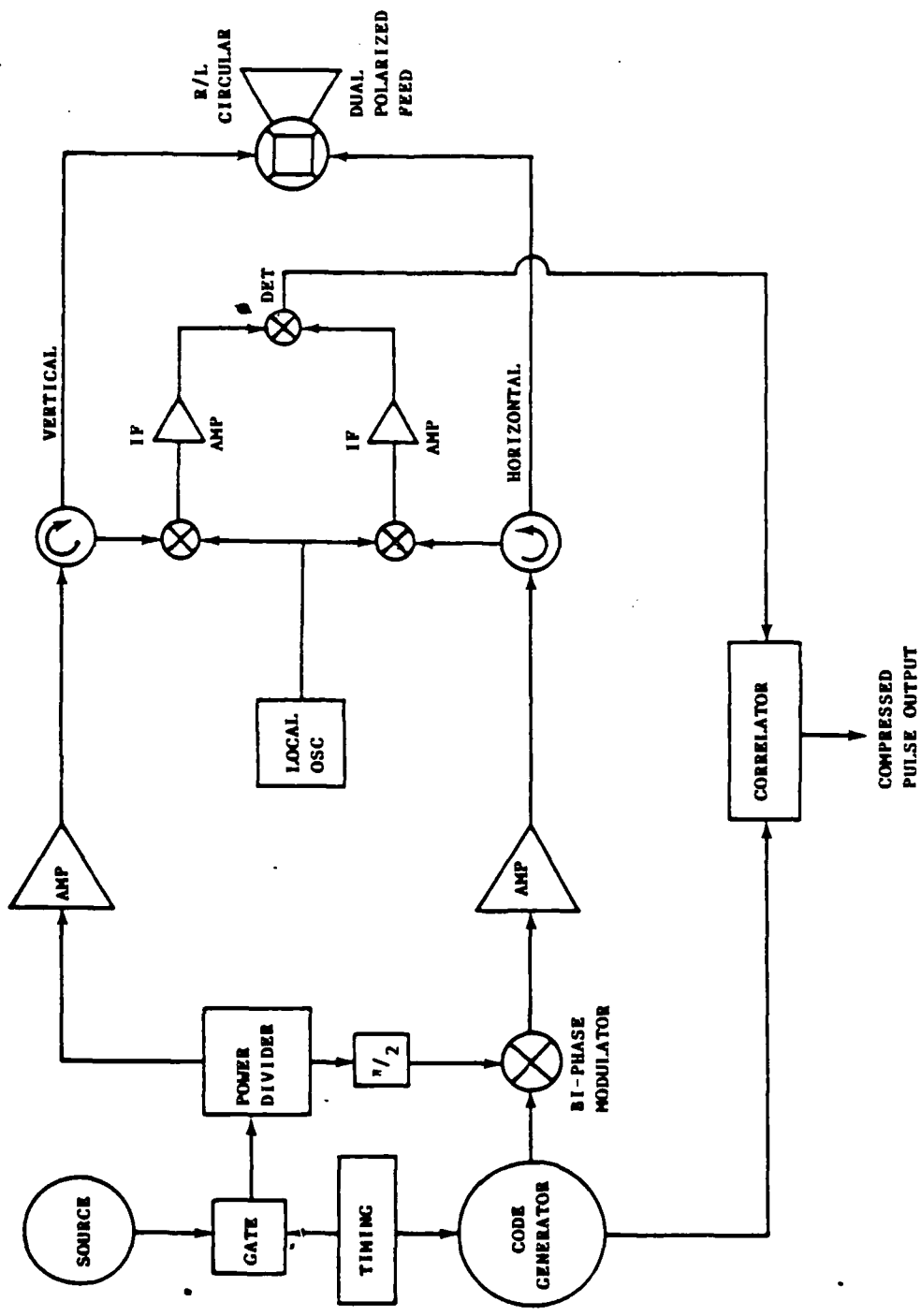

Figure 1. Polarization pulse compression system.

odd reflector will return a pulse with the polarization sense of each subpulse element being complemented, resulting in a complemented sequence being received versus that transmitted.

Since the polarization sense takes on two states, right or left, a binary sequence may be used to encode the transmitted pulse. Upon reception, the encoded sequence can be recovered as the polarization sense changes within the pulse. The received and detected sequence can then be cross-correlated with the sequence used at transmission encoding. For even reflection returns a positive correlation will result while for odd reflection returns a negative correlation will be achieved.

Out-of-range responses, in the form of time sidelobes, are always of concern in pulse compression systems. Typically, these are suppressed through amplitude weighing of the received signal, at the expense of decreased range resolution. With only two states of polarization being radiated within the transmitted pulse, it is convenient to apply binary coding. Optimum binary codes such as Barker and maximal-length are applicable to this pulse compression scheme. Such codes offer reduced time sidelobes while a new category called "Group Complementary Codes" offers zero time sidelobes.

Figure 1 depicts a simple implementation in a non-coherent transceiver where only one channel is encoded to establish a positive or negative 90° phase relationship between the two channels. With one channel applied to the vertical port of a dual polarized antenna feed and the other applied to the horizontal port, right or left hand sense circular polarization is radiated in accordance with the bi-phase modulation imposed on one channel. Other configurations are realizable, including coherence with the source. One configuration applies orthogonal codes to each channel while maintaining the plus or minus 90° phase relationship between the two channels. With the codes to each channel being orthogonal, cross-talk between the channels is eliminated and improved polarization isolation results.

The two channels are applied to a dual polarized feed antenna such that a circularly polarized wave of right/left hand sense (within the pulse envelope) is radiated. A received pulse of right hand/left hand sense will result in the output of the two receiver I.F. ports. Ideally, these two signals will be related by plus or minus 90° in phase. Performing a phase detection between the two signals will result in a binary output according to the plus or minus 90° relative phase. For an even bounce reflector, the same right/left hand sense subpulse pattern will be received and the original binary code will be recovered at the phase detector. For an odd bounce reflector the opposite sense polarization pattern will be received and a complement of the original code will be recovered.

The recovered code can be correlated with the original code to achieve the effective pulse compression. Since the recovered code may be the original code or its complement, depending upon the energy reflector, a positive or negative correlation will result as the compressed pulse output.

As with any pulse compression scheme time sidelobes arise because of the redistribution of energy under the ambiguity function. As polarization is

used to carry the modulation and information for pulse compression, time sidelobes likewise arise. Such undesirable responses permit out-of-range target energy to be ambiguous with the desired in-range target response. These undesired responses may be eliminated with the application of binary coding called "Group Complementary Codes". Such codes have the unique property of zero-time-sidelobes.

III. GROUP COMPLEMENTARY CODES

Group Complementary Codes are extensions of the complementary code concept introduced by Golay. The codes discussed here are matrices of K by N binary elements, and the pulse-compression processing involves transforming K long pulses, each coded with one of the K rows of N -bit binary words, into one single short pulse. Therefore, the pulse compression is a composite operation over a number of pulses rather than on a single pulse.

The implementation of the multipulse processing technique could take several forms but would necessarily require the storage of the partial correlation resulting from each of the K pulses to form the composite matrix correlation. One means of implementing the concept would utilize a Charge Coupled Device (CCD) delay line for storage of each of the K pulses correlations. The device would then provide K inputs for the formation of the composite compressed pulse. Another implementation would involve the use of one integrator to accumulate the range-time samples resulting from correlating the K pulses.

A binary group complementary matrix is composed of K rows and N columns with each element being a plus or minus "1". Each row is a code word used to encode each of K radio-frequency pulses using bi-phase modulation.

The first $K-1$ rows are shifted versions of the same maximal-length code word but with an extra bit of value "1" added at the end. The last row of the matrix is composed of all "1"s. Since a new matrix may be established for each unique maximal-length word, M unique matrices exist for M unique code words.

A very large set of group complementary matrices may be generated from this configuration. An initial unique, but square, matrix may be operated upon in four different ways, in combination or separately, to generate new Group Complementary Code matrices while maintaining the desired and beneficial properties: (1) One or more columns may be truncated, (2) Columns or rows may be interchanged, (3) One or more rows may be complemented, and (4) One or more columns may be complemented. For one unique maximal length code and an initial matrix with 16 rows and 15 columns this would result in an upper limit of more than 3.10×10^{36} Group Complementary Code matrices as compared with 2^{NK} possible matrices without including truncated columns. This would be $2^{16(15)}$ or greater than 1.76×10^{72} . An example of a group complementary matrix structure where eight code words are used, each with 6 bits, is shown in Figure 2 with the principal portion of its autocorrelation response.

Group Complementary Codes have another beneficial property which can be exploited in sensor design and development. This feature involves mutual orthogonality of code matrixes. The Group Complementary Code matrix, A , Figure 2, may be operated upon to create new matrices while maintaining the

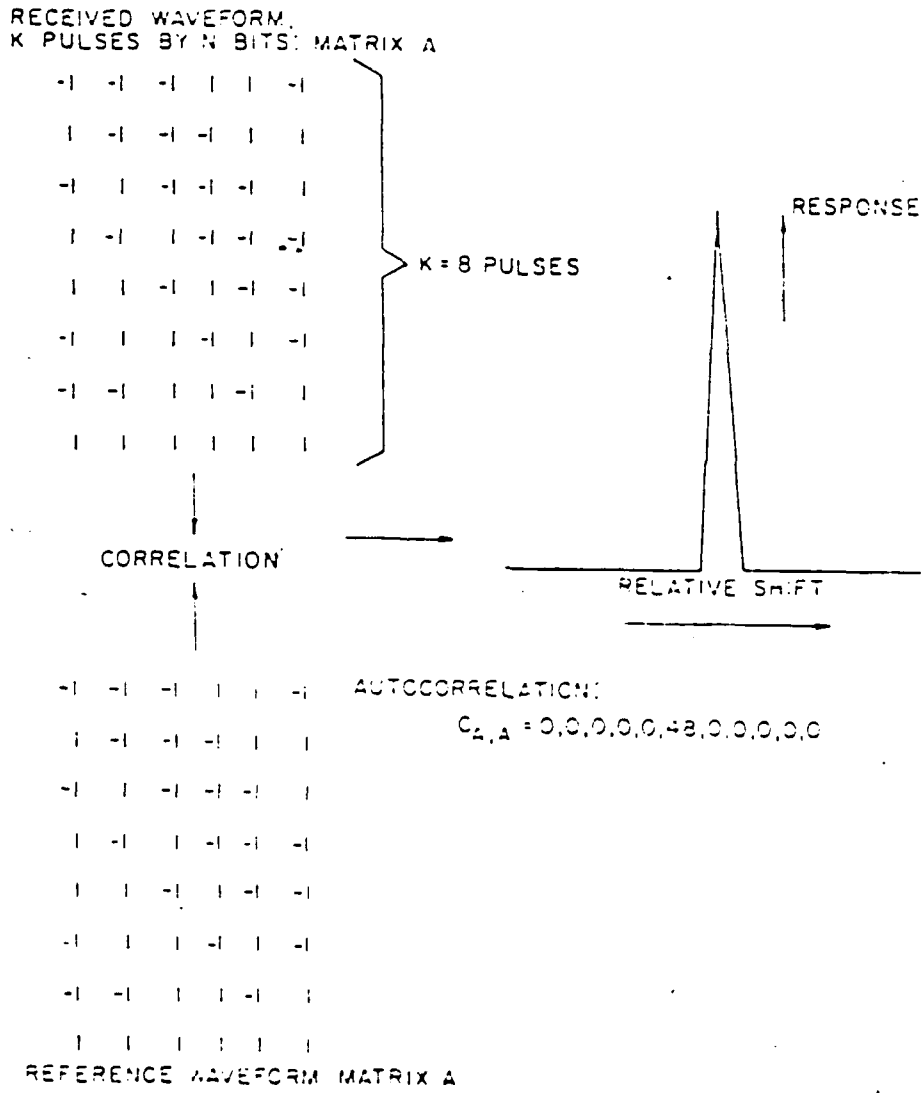

Figure 2. Group complementary matrix structure.

autocorrelation properties of the original matrix. A special case is when N is even and $N/2$ columns of the original matrix are inverted to form a second matrix. For this case, the cross-correlation between the two matrices is identically zero. This is an ideal property for two closely deployed sensors, whose transmissions can be synchronized, each using one of the code matrices for pulse compression. This provides mutually noninterfering operation over the unambiguous interval.

The discriminating properties of a waveform are revealed in the ambiguity surface for the particular waveform. Figure 3 (upper plot) shows the square root of the ambiguity surface for a 16 pulse train with each pulse encoded with a 15 bit maximal length sequence. As can be observed, time sidelobes exist along the range axis near the zero doppler region. In doppler the response falls off as a $\sin X/X$ function for the on-range position. A clutter model is shown in the lower half of the figure with doppler spread along the range axis. This illustrates the out-of-range clutter which competes with the in-range target signal at the peak of the ambiguity plot. If the ridge along the waveform ambiguity surface near zero doppler were eliminated, only that clutter co-located with the peak response would compete with the target return.

Group Complementary Codes offer this desired reduction in the ambiguity surface along the zero doppler response for range positions along the unambiguous interval. Figure 4 is a plot of the ambiguity surface (square root of same for emphasis) for a Group Complementary Coded waveform. Here 16 pulses are each encoded with 15 bits of code, each code being one row of the code matrix. In the near-zero doppler region, the range response has been reduced and the time sidelobes are truly zero along the zero doppler extent in range.

IV. COMBINING GROUP COMPLEMENTARY CODES WITH POLARIZATION MODULATION

The basic approach of encoding one channel with a bi-phase code such that a plus or minus 90° phase relation exist between the channels for each sub-pulse element can benefit in time sidelobe performance through the use of Group Complementary Codes. Any out-of-range responses will be excluded from in-range responses because of the zero-time-sidelobe nature of these codes. Consequently polarimetric properties of reflectors, targets, clutter, etc., may be enhanced by this additional discrimination.

Some target or reflector configurations can be envisioned wherein the approach of encoding only one channel of the transmission may result in out-of-range reflector contributions to in-range reflector responses or result in no response to a reflector. Two cases independent of the code used, will be illustrated: (1) If the reflector depolarizes the return such that either the horizontal or vertical component is absent in the received signal, the phase detection process will not recover a received code; (2) If two reflectors are separated in range (one returning opposite circular polarization and the other only linear polarization) a situation can be generated where the linear reflector will look like a sidelobe of the circular reflector. Neither of these cases would result if each channel of the transceiver is encoded separately. Likewise doppler insensitivity would not be achieved. With each channel encoded separately pulse compression would be achieved on each channel with or without time sidelobes, depending upon the codes used.

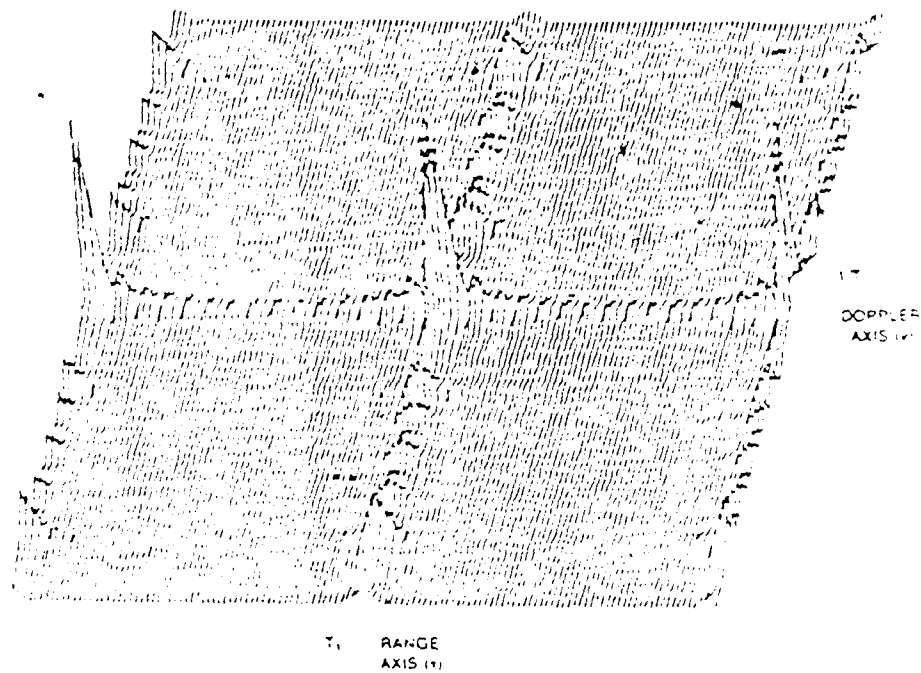

Square root of ambiguity surface for 16 pulse train (15 bit missequence code)

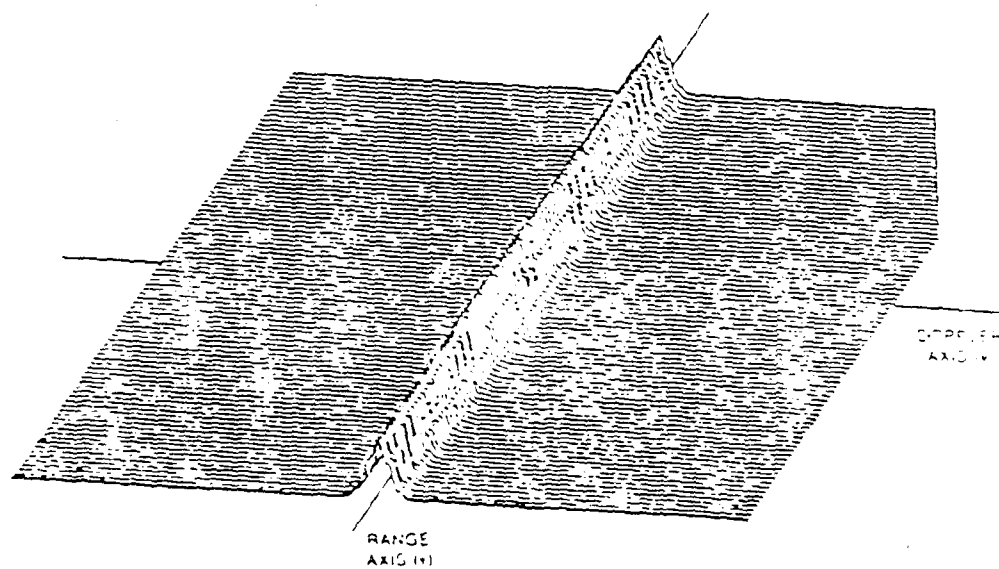

Figure 3. Clutter model: $w(v) = \exp [-(1/2)(v/c)^2]$.

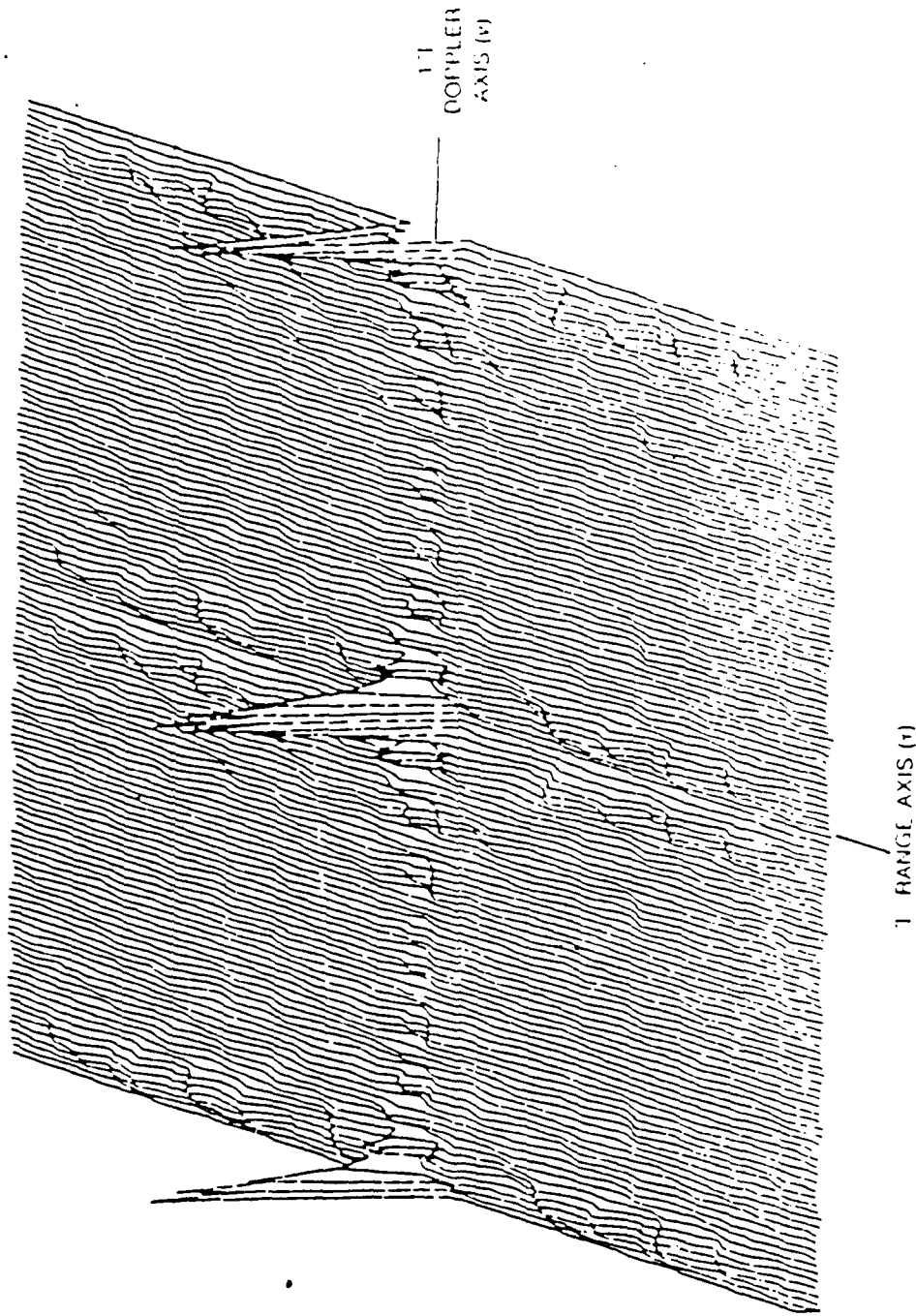

Figure 4. Square root of ambiguity surface $[X(\tau, \nu)]^{1/2}$ for $K = 16$, $N = 15$.

Group Complementary Codes can be obtained which are orthogonal. With use of these on each channel, cross-talk between channels would not occur and polarization isolation would be improved over that realized with a given antenna system.

Coding of only one channel versus coding of two channels has not been analyzed adequately and offers the need for further research.

V. SUMMARY

A different approach to pulse compression has been presented. Instead of operating upon the phase of an RF carrier to achieve wide bandwidths for pulse compression, the polarization of the radiated wave is encoded for subsequent cross-correlation with the encoding waveform. In reality the phase of two carriers are operated upon such that their relative phase carries the coding. Consequently, a moving reflector will operate upon the phase of each carrier in the same manner with preservation of the relative phase between the two and alternately the code. This should result in insensitivity to doppler as opposed to the bi-phase modulated carrier case where increased doppler shifts introduce increased loss in correlation.

Application of Group Complementary Coding to the pulse compression approach using polarization as the information carrier offers improved performance through properties of zero time-sidelobes and orthogonality.

Polarization characteristics of targets and clutter can be enhanced through the use of Group Complementary Coding because of their features. Further research is necessary to realize these benefits and the optimum implementation of such codes in pulse compression through polarization control.

DISTRIBUTION LIST

	<u>Copies</u>
US Army Materiel Systems Analysis Activity ATTN: AMXSU-MP Aberdeen Proving Ground, Maryland 21005	1
ITT Research Institute ATTN: GACIAC 10 West 35th Street Chicago, Illinois 60616	1
AMSMI-RD, R. McCorkle	1
Dr. Rhoades	1
-RD-AS, Mr. Todd	1
Mr. Jackson	1
Mr. Pittman	1
-RD-AS-RF, Mr. Holliday	10
Mr. Lawler	1
Mr. Russell	1
-RD-AS-RA, Mr. Low	1
-RD-AS-MM, Mr. Mangus	1
-RD-AS-SS, Mr. Hatcher	1
-RD-AC-AD, Mr. Morgan	1
-RD-RE, Dr. Hartman	1
-RD-CS-T	1
-RD-CS-R	15
AMSMI-GC-IP, Mr. Fred Bush	1

DATE
ILMED
-88