

12

TECHNICAL REPORT GL-86-21



US Army Corps of Engineers

EVALUATION AND REPAIR OF WAR-DAMAGED PORT FACILITIES

Report 4

CONCEPTS FOR EXPEDIENT WAR-DAMAGE REPAIR OF PIER AND WHARF SUPPORT STRUCTURES

by

Eastport International, Inc.
501 Prince George's Boulevard
Upper Marlboro, Maryland 20772

DEPARTMENT OF THE ARMY
Waterways Experiment Station, Corps of Engineers
PO Box 631, Vicksburg, Mississippi 39180-0631

AD-A178 055

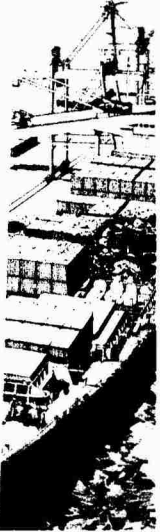

DTIC ELECTED
MAR 20 1987
S D

October 1986

Report 4 of a Series

Approved For Public Release; Distribution Unlimited

Prepared for DEPARTMENT OF THE ARMY
US Army Corps of Engineers
Washington DC 20314-1000

Under Project AT40, Task CO, Work Unit 009

Monitored by Geotechnical Laboratory
US Army Engineer Waterways Experiment Station
PO Box 631, Vicksburg, Mississippi 39180-0631



DTIC FILE COPY

87 3

19 120

REPORT DOCUMENTATION PAGE

1a. REPORT SECURITY CLASSIFICATION Unclassified			1b. RESTRICTIVE MARKINGS			
2a. SECURITY CLASSIFICATION AUTHORITY			3. DISTRIBUTION / AVAILABILITY OF REPORT Approved for public release; distribution unlimited			
2b. DECLASSIFICATION / DOWNGRADING SCHEDULE						
4. PERFORMING ORGANIZATION REPORT NUMBER(S) Technical Report GL-86-21			5. MONITORING ORGANIZATION REPORT NUMBER(S)			
6a. NAME OF PERFORMING ORGANIZATION Eastport International, Inc.		6b. OFFICE SYMBOL (if applicable)	7a. NAME OF MONITORING ORGANIZATION USAEWES Geotechnical Laboratory			
6c. ADDRESS (City, State, and ZIP Code) 501 Prince George's Boulevard Upper Marlboro, MD 20772			7b. ADDRESS (City, State, and ZIP Code) PO Box 631 Vicksburg, MS 39180-0631			
8a. NAME OF FUNDING / SPONSORING ORGANIZATION US Army Corps of Engineers		8b. OFFICE SYMBOL (if applicable)	9. PROCUREMENT INSTRUMENT IDENTIFICATION NUMBER			
8c. ADDRESS (City, State, and ZIP Code) Washington, DC 20314-1000			10. SOURCE OF FUNDING NUMBERS			
			PROGRAM ELEMENT NO.	PROJECT NO. AT40	TASK NO. CO	WORK UNIT ACCESSION NO. 009
11. TITLE (Include Security Classification) Evaluation and Repair of War-Damaged Port Facilities, Report 4; Concepts for Expedient War-Damage Repair of Pier and Wharf Support Structures						
12. PERSONAL AUTHOR(S) Eastport International, Inc.						
13a. TYPE OF REPORT Final report		13b. TIME COVERED FROM May 85 TO Feb 86		14. DATE OF REPORT (Year, Month, Day) October 1986		15. PAGE COUNT 122
16. SUPPLEMENTARY NOTATION Available from National Technical Information Service, 5285 Port Royal Road, Springfield, VA 22161.						
17. COSATI CODES			18. SUBJECT TERMS (Continue on reverse if necessary and identify by block number) Harbors Piers Hydraulic structures Wharves			
FIELD	GROUP	SUB-GROUP				
			19. ABSTRACT (Continue on reverse if necessary and identify by block number) <p>The military is dependent on supplying large volumes of cargo in the theater of operations through the use of strategic ports and their facilities. Port facilities are potential targets for hostile forces. Ports can be expected to be attacked in various ways to render the facilities inoperative or to deny access to the facilities. Repairs should be conducted as quickly as possible to restore damaged areas for the transfer of supplies from support ships to shore facilities and inland.</p> <p>The study herein analyzes, develops, and recommends concepts that can be used for the expedient repair of piers, wharves, and quay walls. Specific areas examined include the underwater substructure from the mudline up to the decking interface. Underwater support structure repairs or replacements are necessary before the decks can be repaired and subsequently used.</p>			
20. DISTRIBUTION / AVAILABILITY OF ABSTRACT <input checked="" type="checkbox"/> UNCLASSIFIED/UNLIMITED <input type="checkbox"/> SAME AS RPT. <input type="checkbox"/> DTIC USERS			21. ABSTRACT SECURITY CLASSIFICATION Unclassified			
22a. NAME OF RESPONSIBLE INDIVIDUAL			22b. TELEPHONE (Include Area Code)		22c. OFFICE SYMBOL	

PREFACE

The investigation reported herein was under the sponsorship of the Office, Chief of Engineers (OCE), US Army, and was conducted under Project AT40, Task CO, Work Unit 009, "Evaluation and Repair of War-Damaged Port Facilities." Mr. Austin A. Owen was Technical Monitor for OCE.

This study was conducted by Eastport International, Inc., Upper Marlboro, Maryland, for the Naval Civil Engineering Laboratory (NCEL), Port Hueneme, California. This report documents work prepared for the US Army Engineer Waterways Experiment Station (WES) under MIPR No. A35200-5-0013 with NCEL from May 1985 through February 1986. This work was conducted under the general supervision of Dr. W. F. Marcuson III, Chief, Geotechnical Laboratory (GL), and under the direct supervision of Mr. H. H. Ulery, Jr., Chief, Pavement Systems Division (PSD), GL. Personnel of the PSD involved in this study were Messrs. H. L. Green and R. H. Grau. CPT John W. Talbot, PSD, was instrumental in initial liaison and coordination of this study with NCEL. This work was coordinated and monitored by Mr. C. J. Smith, PSD. This report was edited by Ms. Odell F. Allen, Information Products Division, Information Technology Laboratory.

COL Allen F. Grum, USA, was the previous Director of WES. COL Dwayne G. Lee, CE, is the present Commander and Director. Dr. Robert W. Whalin is Technical Director.



Accession For	
NTIS CRA&I	<input checked="" type="checkbox"/>
DTIC TAB	<input type="checkbox"/>
Unannounced	<input type="checkbox"/>
Justification	
By	
Distribution/	
Availability Codes	
Dist	Avail and/or Special
A-1	

CONTENTS

	<u>Page</u>	
1.0	Introduction - Damage Repair Scenario	5
1.1	Scope of Damage	5
1.2	Repair Assessment	5
1.3	Manpower and Equipment Required	6
1.4	Repair of Support Structures	6
1.5	Repair of the Decking Interface	6
2.0	Background - Generic Structure Definition	6
2.1	Typical Materials	6
2.2	Ranges of Size	6
2.3	Types of Foundations	7
2.4	Types of Decking to Support Interfaces	8
3.0	Damage and Repair Assessment	8
3.1	Inspection Techniques	8
3.2	Methods of Assessment	8
3.3	Load Capacity Evaluation and Assessment	9
3.4	Repair Priorities	9
3.5	Identification of Potential Materials	10
3.6	Time/Manpower and Cost Estimating	11
3.6.1	Time/Estimating	11
3.6.1.1	Weather	11
3.6.1.2	Time to Completion	11
3.6.1.3	Materials	11
3.6.1.4	Equipment	12
3.6.2	Manpower Estimating	12
3.6.2.1	Production Efficiency Guide Chart and Graph	12
3.6.3	Cost Estimating	12
3.7	Tools and Materials Estimating	20
3.8	Repair Versus Replace Decisions	21
4.0	Demolition and Rubble Removal	21
4.1	Improvised Explosives	21
4.2	Demolition Techniques	22
4.2.1	Wood	22
4.2.2	Concrete	22
4.2.3	Steel	22
4.2.4	Ordnance Removal	23
4.3	Rubble Clearance from Decking Interface	23
4.4	Rubble Clearance from Piling	23
4.5	Personnel and Diver Safety	25
4.6	Site Preparation	28
4.6.1	Airlift	28
4.6.2	Dredging	30

	<u>Page</u>
5.0 Transportation and Erection of Materials	32
5.1 Lifting Techniques	32
5.1.1 Gin Pole	32
5.1.1.1 Materials Selection and Sizing	33
5.1.1.2 Vertical Spar and Guylines	33
5.1.1.3 Guyline Sizing	35
5.1.1.4 Rigging	36
5.1.2 Shears	36
5.1.2.1 Rigging	36
5.1.2.2 Erecting	37
5.1.3 Tripod	37
5.1.3.1 Rigging	38
5.1.3.2 Erecting	39
5.2 Expedient Winch	39
6.0 Repair Concepts for Foundations	41
6.1 Steel Beam Foundation	42
6.2 Concrete Foundation	45
6.3 Container Floor or Steel Plate Foundation	48
6.4 Rubble Foundation	51
7.0 Repair Concepts for Support Structures	53
7.1 Wood Columns	58
7.1.1 Bundled Wood Columns	60
7.2 Steel Columns	64
7.2.1 Welded Steel Rail Columns	68
7.3 Reinforced Concrete Pile Repairs	72
7.4 Container Used as Pile Replacement	75
7.5 Sheet Piles	83
7.5.1 Expedient Sheet Piling	83
7.5.2 Container Floor Used as Sheet Piling	85
7.5.3 Timber Sheet Piling	86
7.5.4 Patching A Steel Sheet Pile Section	87
7.6 Trusses	88
7.6.1 Timber Truss	88
7.6.2 Steel Truss	94
7.7 Other Salvaged Materials	102
7.7.1 Leveling Jack Repair	102
8.0 Repair Concepts for Decking to Support Interface	103
8.1 Bracing Methods	103
8.2 Connecting Methods	103
BIBLIOGRAPHY	115
APPENDIX A: EXPEDIENT CUTTING ELECTRODE FABRICATION	A1

CONVERSION FACTORS, NON-SI TO SI (METRIC)
UNITS OF MEASUREMENT

Non-SI units of measurement used in this report can be converted to SI (metric) units as follows:

<u>Multiply</u>	<u>By</u>	<u>To Obtain</u>
cubic feet	0.02831685	cubic metres
cubic yard	0.7645549	cubic metres
degrees (angle)	0.01745329	radians
feet	0.3048	metres
foot-pounds (force)	1.355818	metre-newtons or joules
gallons	3.785412	cubic decimetres
gallons per square yard	4.5273	cubic decimetres per square metre
inches	2.54	centimetres
pounds (force) per foot	14.5939	newtons per metre
pounds (force) per square foot	47.88026	pascals
pounds (force) per square inch	6.894757	kilopascals
pounds (mass)	0.4535924	kilograms
pounds (mass) per cubic foot	16.01846	kilograms per cubic metre
square inches	6.4516	square centimetres
square feet	0.09290304	square metres
tons (2000 pounds, mass)	907.1847	kilograms
yards	0.9144	metres

1.0 Introduction - Damage Repair Scenario

Logistical support of military forces in the theater of operations is a task that must be continuous from initial involvement to after the conflict. One way of supplying troops is through the use of strategic port facilities. Due to the vital importance of these ports, it is necessary that they always be capable of optimum use. It is highly probable that, due to their location in the theater of operations, they will be potential targets for destruction by hostile forces. As such, it is critical that after an attack on a port, that repairs be made as quickly as possible. Repairs will be accomplished by a port construction company using conventional tools, techniques, and materials. However, due to the location of the port, and disruption of supplies, conventional repair materials and equipment may not be readily available. In order to prepare for this contingency it is highly desirable to find ways of doing repairs with materials and tools that are commonly found in areas around or in the port. Depending on the type of repair, the facility will have either full or partial capability. The pier or wharf repair should allow limited weight loading and unloading operations to take place until permanent repairs can be made. The port of repair is assumed to be comparable to the Norfolk International Container Terminal or the Norfolk Naval Station.

The purpose of this report is to analyze, develop, and recommend concepts that can be used for the expedient repair of port facilities. The focus is on the repair of piers, wharves, and quay walls. These structures may be constructed of timber, steel, or concrete. The area to be examined is from the underwater substructure up to the decking interface.

1.1 Scope of Damage

Damage to the port facilities is assumed to occur as a result of 500 lb* general purpose bombs that are set either to explode on impact or have been delay fused. Crater size is expected to be approximately 8.4 ft in diameter. It is anticipated that an area of damage may encompass multiple piles. The piles may be either partially damaged or completely destroyed requiring replacement. Wharves and quay walls may have large portions missing or be disabled with substantial losses of fill material.

1.2 Repair Assessment

Assessment of repairs required will initially come from personnel who are first onsite and can provide the greatest quantity of accurate information. Most information provided will be from visual inspection, detailed sketches of the damaged area, photographs of the damaged area, and examination of the surrounding undamaged structure. Assessing the repair requirements for the underwater portions of pier substructures can be done when a properly trained diver is available. The diver will be able to examine, photograph, and sketch the damaged component(s) and provide to the officer in charge adequate and accurate data of the damage done. This data will be evaluated and will enable a more refined repair estimate.

* A table of factors for converting non-SI units of measurement to SI (metric) units is presented on page 4.

1.3 Manpower and Equipment Required

The expedient repair of the damaged substructure at a port facility will be done by a port construction company which is attached to a combat heavy engineer battalion. Particular importance is given to the availability of a properly trained unit of divers thus allowing a thorough investigation and an improved repair capability. As with all repairs, they can be done most effectively by using the proper tools that are suited to a particular task. The expedient repairs in this report were developed to require a minimum of specialized equipment, and most of the repairs could be done with hand tools.

1.4 Repair of Support Structures

The damage scenario indicates that substantial destruction will be done to quays, wharves, and piers. Included in this will be considerable damage to the substructures supporting these areas. The support structures will require repair or replacement before the decks can be repaired and subsequently used. The structures will be repaired with the best available materials and techniques. If conventional materials and tools are not immediately available, implementation of expedient repair materials and techniques using convenient tools will be initiated.

1.5 Repair of the Decking Interface

When replacing piles that have been damaged, it will also be necessary to use a pile to cap interface to assure that deck loading is directed to the maximum projected pile area. The interface must be able to withstand destabilizing forces such as wind, tide, docking, and vehicle movement on the deck that could shift the deck cap or pile from the optimum position for distributing deck loads. The interfaces used should be capable of application to a variety of damage conditions and repair materials.

2.0 Background - Generic Structure Definition

2.1 Typical Materials

The materials used in pier, quay, and wharf construction are generally the same throughout the world. The generic port used in this report is anticipated to use concrete, steel, and wood as the primary materials of construction. The concrete is reinforced with steel rebar for additional strength. The generic port is not assumed to be in an extremely cold area and will not require the use of any high technology materials such as high strength, low temperature steels. Materials for normal structure maintenance will be used. The steel used for repairs will be coated with a protective layer of paint to reduce the rate of material deterioration. The wood piles will be pressure treated with creosote or other wood preservative and of a type that will be as resistant as possible to teredo and other marine creature attack. Quays and wharves will have steel or wood sheet piling and an earthen backfill.

2.2 Ranges of Size

The structure is anticipated to be from 700 to 1,000 ft long and is capable of handling average size container ships. There are numerous sizes of piles used

for construction and are dependent on the load to be carried and local soil conditions. There are certain ranges of size that are commonly used. Piles constructed of concrete that are used for marine construction will generally fall into two shape categories, square or octagonal. Square concrete piles will usually be 12, 16, or 20 in. on each side of the cross section. The octagonal concrete piles will usually come in sizes of 16, 20, or 24 in. measured with the cross corners. The maximum length of concrete piles that are not poured in place is limited by the handling method. Prefabricated concrete piles will generally have a maximum length of 73 ft. Steel piles can vary in shape from round pipe cross sections to flanged cross sections. The pipe cross sections may have diameters from 8 to 16 in. Steel wide flange sections commonly used are 14 in., 73 lb WF and 12 in., 53 lb WF sections. Steel pile lengths can exceed 80 ft depending on soil conditions. Wood pile tip diameters can vary from 8 to 11 in. for less than 40 ft lengths, and 6 to 8 in. for more than 40 ft lengths. Wood pile butt diameters can vary from 12 to 18 in. for less than 40 ft lengths, and 12 to 20 in. for more than 40 ft lengths. Wood pile lengths are generally in the 60 ft range.

2.3 Types of Foundations

Due to the types of soil conditions found in many port locations, bearing capacities are fairly poor. See Table 2-1 for bearing capacities of various types of soil. Because of the soil conditions, the use of frictional resistance piles which are driven by pile drivers is preferred over end bearing columns. To use an end bearing column the cross-sectional area of the pile would need to be vastly increased to optimize soil bearing resistance. A frictional resistance pile uses skin friction between the soil and the driven pile for withstanding vertical forces and is the type anticipated in the generic port.

Table 2-1. Safe Bearing of Soils

Nature of Soil	Safe Bearing Capacity tons/sq ft
Hard ledge such as granite, trap, etc.	25 - 100
Sound shale and other medium rock	10 - 15
Hardpan, cemented sand, gravel	8 - 10
Soft rock, disintegrated ledge	5 - 10
Compact sand and gravel	4 - 6
Hard clay	4 - 5
Gravel coarse sand	4 - 5
Loose, medium, and coarse sand, fine compact sand	1.5 - 4
Medium clay, stiff but capable of being spaded	2 - 4
Fine loose sand	1 - 2
Soft clay	1

2.4 Types of Decking To Support Interfaces

Once the method of pile repair and type of materials have been chosen it will be necessary to decide upon the type of interface for the pile to decking support structure. If the damaged structure was concrete, the pile to cap was probably poured together as a single unit. The repair to a concrete structure thus would require that fragmented concrete be removed and the cap be given a flat surface to interface with the pile repair material. The decking interface connection used to couple the pile and the cap would then be used. If steel or wood piles were used, the damaged cap to pile interface would also require fragment removal and a flat surface prepared for the pile to cap coupling to be used. The interfaces must be easily fabricated from commonly available materials and be adaptable to various types of deck support structures.

3.0 Damage and Repair Assessment

3.1 Inspection Techniques

Research conducted in the past regarding inspection techniques for marine facilities have concentrated on damage that has occurred through biodeterioration. No specific techniques have been found to address mechanically damaged marine facilities other than by visual observation. Mechanical damage is not the type of damage that can be statistically evaluated as is the case of biodeterioration.

The use of acoustic imaging systems has proven to be impractical because of the problem of properly filtering out reverberation in the acoustic returns. In a war-damage scenario, there will be even more acoustic targets to create confusion. Acoustic transducers and radiation have proven to be effective in many cases, however, working under an unsafe pier with severely restricted space and substantial image clutter from debris should effectually eliminate these methods as likely candidates.

Trained divers are the best method to inspect war-damaged piers and wharves. If the underwater condition is too hazardous to put personnel in the water, small remotely operated vehicles (ROV's) can be very effective so long as the ROV does not become entangled in the debris on the sea floor. The best inspection technique is to use a combination of trained divers and ROV's. Divers should have communications capabilities with the surface, and it is highly desirable that they have a portable underwater video system to provide surface personnel with visual information.

3.2 Methods of Assessment

Upon completion of visual surface inspection and making detailed sketches of all pertinent items it is necessary to do a detailed inspection of damaged areas that cannot be accurately assessed from the surface. A properly trained diver would perform a 100 percent swim inspection of the damaged zone, extending the survey to the point that undamaged facilities are ensured. The assessment should be both verbal and written. Sketches should be made that are proportionally accurate and show the existing attitude of the damaged member correctly. Photographic coverage is also highly desirable. The data

contained in the report must be sufficient to permit the person in charge of the assessment to make decisions on what must be repaired or replaced. Physical measurements of the extent of damage must also be included.

While performing the damage assessment, particular attention must be given to:

- Types and sizes of materials in place
- Sizes of members to be repaired or replaced
- Potential access and staging areas
- Possible salvageable materials to be used in repairs
- Obstructions
- Water depth
- Tides and current indicators
- Availability of utilities
- Other data that may be useful in developing repair techniques

3.3 Load Capacity Evaluation and Assessment

The goal of the repair is to return the facility to a condition of maximum possible operation in the shortest time possible. Determination of the undamaged load capacity should take into consideration the overall condition of the facility, the operational need, and the original design factors of safety (FOS). A generalized approach that may be used for FOS incorporated into the original design is:

Steel material : FOS 1.5 - 2.0

Concrete material : FOS 2.0 - 2.5

Wood material : FOS 2.5 - 3.0

The aforementioned FOS may not be totally accurate for every facility but have been commonly used in past pier and wharf designs. It is possible that with built-in factors of safety, a facility may be able to perform at some minimum acceptable level of use, even if it appears damaged. This means that where the original design may have called for six piles, the same loading could be done with less piles but at a substantially reduced factor of safety. Evaluation of using damaged piers or wharves should only be done onsite and by qualified personnel.

3.4 Repair Priorities

In order to allow for the most effective utilization of a damaged facility in the shortest period of time, repair of damaged areas must be given levels of importance by the officer in charge. Consideration must be given to

immediate safety, onsite operational requirements, prior operational capabilities, and available manpower, materials, and tools.

Subsequent to establishing priorities for the facility as a whole, it is necessary to establish priorities for specific repairs. When repairing sub-structures the existing pile foundation must either be made sound or replaced. Upon foundation preparation the pile repair or replacement can be done and fastening to the cap accomplished.

3.5 Identification of Potential Materials

Following hostile action on a port, there will be substantial debris to be disposed of and repairs to be made. If repairs must be done only with the tools and materials on hand, potential repair materials must be identified as soon as possible. A good knowledge of the repair assessment and creativity with materials application will assist in optimizing the identification of possible repair materials. Expedient sheet piling can be fabricated from salvaged materials and used to repair quay walls and wharves. This can be accomplished in several ways; among these are:

1. Galvanized warehouse roofing used in multiple sheets along with deadmen.
2. Railroad rails, angle iron, channel, or other structural steel shapes can be used as vertical members and wood planks or boards can be put in between them to make a sheet piling.

Damaged piling can be repaired or replaced with numerous items found in a port area. Among the potential repair materials are:

1. Structural steel shapes individually or joined together to comprise a composite pile.
2. Steel pipe used individually as a pile or bundled together to make a composite pile.
3. Telephone poles used as piles.
4. Culvert pipe used as a repair form and filled with concrete.
5. Fifty-five gal drums used as a repair form and filled with concrete.

If a replacement pile is required and a foundation is not available, an expedient foundation and column may be used in place of a driven pile. Among the items that can be used as expedient foundations are:

1. Fifty-five gal drums cut lengthwise and filled with concrete to increase the footing area.
2. Portions of the floor of International Organization for Standardization containers used in constructing an expedient column foot pad.
3. Steel sheets reinforced to act as foundations for columns.

The items listed above are in no way a comprehensive list. Additional materials and techniques are detailed in following sections. Every facility is going to have access to different potential repair materials. The primary limiting factor to finding usable materials is creativity of application. Numerous kinds of materials can be used for various purposes and during an expedient repair scenario, when conventional repair materials are not available, improvisation is the key word.

3.6 Time/Manpower and Cost Estimating

3.6.1 Time/Estimating

To properly conduct a complete and efficient repair operation, it is necessary to assign priorities to tasks and have a reasonable estimate of the time required to complete them. This section, used in conjunction with the Seabee Planners and Estimators Handbook, NAVFAC P-405, will provide assistance in estimating project requirements. Numerous factors must be taken into account when estimating time required for job completion. Among these factors are the weather, experience and skill, number of personnel, and availability of materials and equipment. A less than adequate resource in any one of these areas will substantially increase the time required to complete a job. It is quite likely that in a repair scenario one or more of these areas will be less than suitable. Insight regarding potential hindrances will allow for a better understanding of project delays.

3.6.1.1 Weather

Weather conditions can have a substantial effect on the number of hours required for project completion. Cold damp climates, as well as hot humid climates, reduce a man's daily production and affect the output of construction equipment.

Rain in the midst of a construction operation slows production and sometimes causes additional work, thus increasing the number of man-hours required for repair. When divers are required to go into water for demolition or column location and the ocean conditions are not safe enough for a job to be done, all subsequent phases of that project will be delayed.

3.6.1.2 Time to Completion

The time allotted for project completion can directly affect the time that it actually takes to do the work. Due to the wartime situation and the need for repairs to be done as rapidly as possible, it is likely that personnel are going to be required to work in shifts continually until the project is completed. A man's production per hour decreases sharply under these conditions. When work areas are crowded with too many people, they are likely to distract others in the area. The results are a reduction in efficiency so that more man-days are required to accomplish the same amount of work.

3.6.1.3 Materials

The various types of materials to be handled and their unconventional use are going to result in materials handling taking longer than usual. The extra

handling required with expedient sheet piling is one example of a delay that would not occur if conventional sheet piling were available. Time requirements resulting from the use of expedient materials will need to be assessed onsite and on a case by case basis.

3.6.1.4 Equipment

The type of equipment required will directly affect the amount of time required to perform a particular task. This area is one that is much more difficult to estimate due to site requirements that may dictate jury-rigging for one or more tasks. This area must be determined onsite and may require frequent modifications.

3.6.2 Manpower Estimating

Manpower estimates consist of a listing of the number of direct labor man-days required to complete the various activities for a specific project. Man-hour estimates using Tables 3-1 through 3-20 can be used to ascertain the required number of man-days. In addition to the tables, other factors such as the weather and operational time frame will dictate manpower requirements.

3.6.2.1 Production Efficiency Guide Chart and Graph

The Production Efficiency Guide Chart (Table 3-21) lists eight factors (production elements) that directly affect production. Each element is subdivided into three areas for evaluation. The estimator evaluates each production element at some specific percentage between 25 and 100, according to an analysis of the foreseen conditions. The average of the eight evaluations is the overall production efficiency percentage. The percentage is then converted to a delay factor on the production efficiency graph (Figure 3-1). The estimated number of hours is then multiplied by the delay factor to give an adjusted man-hour estimate.

This report will assume an estimated average production of 67 percent as shown in Table 3-21. This percentage used in conjunction with the Production Efficiency Graph will show a delay factor of 1.00. A delay of 0.66 represents peak production.

Assume from Tables 3-1 through 3-20 that an estimated six man-hours are extracted for a given unit of work. To adjust this figure to the conditions evaluated on a job, assume that the average of foreseen conditions rated by an individual from Table 3-21 is 87 percent. Using this percentage, the corresponding delay factor read off the Production Efficiency Graph is 0.80.

The adjusted man-hour estimate is found by multiplying this delay factor by the man-hours from these estimating tables. Thus, for a job estimated at six man-hours and a delay factor of 0.80, the corresponding repair time estimate is 4.8 man-hours.

3.6.3 Cost Estimating

Estimating the cost of an expedient repair project is very difficult to do

Table 3-1. Wood Pile Dolphins

WORK ELEMENT DESCRIPTION	UNIT	MAN-HOURS PER UNIT
Place in Leads and Drive	Each	.8
Lash with Wire Rope	Each	.75
Install Fenders	Each	.6
Fender Pile	Each	.75

NOTES:

1. Based on 50' piles.

Table 3-2. Piledriving

WORK ELEMENT DESCRIPTION	UNIT	MAN-HOURS PER UNIT
25' Wood Piling	Each	3
50' Wood Piling	Each	6.5
75' Wood Piling	Each	9.6
25' Steel Piling	Each	4
50' Steel Piling	Each	7.2
75' Steel Piling	Each	12
40' Precast Concrete Piling	Each	13.2
60' Precast Concrete Piling	Each	18
60' Precast Concrete Piling	Each	24
Steel Sheet Piling	1000 S.F.	102
Assemble and Rig Leads and Hammer	Each	48
Dismantle Leads and Hammer	Each	32

NOTES:

1. Man-Hour figures are preliminary estimate only. The many variables of this work require on-site determinations for accurate estimates
2. Factors of importance are: Design, soil, equipment and method used, tides, access to site, currents, materials storage, etc
3. Work included is preparation of pile, placing in leads, driving and cut off
4. For concrete filled, fluted hollow steel piling and pipe piling for spudding pontoon smallcraft finger piers, use the steel bearing pile figures.

Table 3-3. Pile Bracing and Capping

WORK ELEMENT DESCRIPTION	UNIT	MAN-HOURS PER UNIT
Diagonal Bracing	Each	6.5
Horizontal Bracing	Pair	8
Wood Caps	1000 LF	480
Concrete Caps	LF	3.2
Steel Caps	1000 LF	480

NOTES:

1. Based on bolting or drifting members in place.

Table 3-4. Pile Extraction

WORK ELEMENT DESCRIPTION	UNIT	MAN-HOURS PER UNIT
Wood Bearing Piles	Each	2
Wood Sheet Piling	1000 SF	24
Steel Sheet Piling	1000 SF	28
Piles Cut-Off Below Water Line	Each	2.5

NOTES:

1. Based on using pile extractor.

Table 3-5. Miscellaneous Pier Hardware

WORK ELEMENT DESCRIPTION	UNIT	MAN-HOURS PER UNIT
Bits	Each	13
Bollards	Each	16
Chairs	Each	13
Cleats	Each	11
Pad Eyes	Each	2.5

Table 3-6. Structural Steel Fabrication

WORK ELEMENT DESCRIPTION	UNIT	MAN-HOURS PER UNIT
FABRICATE: Structural Frames	Ton	16
Columns	Ton	16
Girders	Ton	16
Beams	Ton	10.4
Trusses	Ton	6
Purlins, Girts and Struts	Ton	12.8
Frames for Openings	Ton	2.8
Stairs	Ton	28
Platforms	Ton	36
Railings (Simple Tube/Pipe)	10 Lin. Ft.	16

NOTES:

1. Fabrication of structural steel includes cutting, riveting, burning, drilling, milling, fitting, assembling, welding, bolting, storing, loading, and hauling to the job site.
2. Man-hour units are based on bolted connections, if sections are to be welded add 25 percent for welded joint preparation.

Table 3-7. Reinforcing Steel Fabrication

MAN-HOURS REQUIRED FOR MAKING 100 BENDS OR HOOKS				
SIZE OF BAR IN INCHES	BY HAND		BY MACHINE	
	HOURS	HOURS	HOURS	HOURS
½" or Less	4	6	1.5	2.5
¾", ¾" and 1"	5	8	2	3
1" and 1 ½"	6	10	2.5	4
1 ½" and 1 ¾"	7	12	3	5

NOTES:

1. Reinforcing steel fabrication includes cutting, bundling, tagging, Assembly and tying into mats and beams in the shop are also included.

Table 3-8. Placing Reinforcing Steel

LABOR HOURS FOR PLACING 100 BARS			
	LENGTH OF BAR IN FEET		
	Under 10	10 - 20	20 - 30
½" or less	6	7	6
¾", ¾" and 1"	7	8	9.5
1" and 1 ½"	6	10	11.5
1 ½" and 1 ¾"	9	12	14
WELDED WIRE FABRIC	UNIT	MAN-HOURS	
Slabs on Grade, Concrete Paving, Precast Roof Panels	100 SF	.8	
Curbs and Head Walls	100 SF	1	

NOTE:

1. Placement of reinforcing steel includes handling into place, tying, supporting, and any cutting which becomes necessary at the site such as cutting around imbedded items or cutting stock lengths of straight bars to fit slab dimensions.
2. Man-Hour estimates are based on all reinforcing steel being shop fabricated (cut to length and bent ready to place in the structure).
3. If reinforcing steel is to be welded in place add 50 percent to the time factor.

Table 3-9. Structural Steel Erection

WORK ELEMENT DESCRIPTION	UNIT	MAN-HOURS PER UNIT
UNLOAD, ERECT AND PLUMB		
Columns	Ton	13.6
Beams	Ton	13.6
Girders	Ton	9
Trusses	Ton	17
Girts and Purlins	Ton	11.9
Bracing and Tiers	Ton	17.9
Light Framing	Ton	23.8
HIGH STRENGTH BOLTING		
	100 bolts	7.5
Grating	1,000 Sq. Ft.	192

NOTES:

1. Erection of structural steel includes handling, erecting, temporary bolting, plumbing, leveling, high strength bolting and/or welding.
2. Man-hour figures are based on using new construction materials

Table 3-10. Welding Structural Steel

Per L.F. Material Thickness in Man Hours

	HORIZONTAL	VERTICAL	OVERHEAD
Filet Arc Welding			
1/8"	.15	.27	.36
3/16"	.37	.36	.42
1/4"	.45	.49	.53
5/16"	.49	.69	.93
3/8"	.76	.93	1.1
1/2"	1.05	1.1	1.4
3/4"	2.06	1.9	2.3
1"	2.4	2.3	2.6
Butt Welding			
1/8"	.53	.55	.61
3/16"	.76	.63	.79
1/4"	.87	.73	.93
5/16"	1.05	.93	1.1
3/8"	1.9	1.5	2.3
1/2"	2.06	1.7	2.5
3/4"	3.4	2.8	3.7
1"	3.7	3.4	4.3

Table 3-11. Flame Cutting Structural Steel

WORK ELEMENT DESCRIPTION	MAN-HOURS PER 10 LIN. FT.
1/8"	1.9
3/16"	2.0
1/4"	2.3
5/16"	2.3
3/8"	2.4
1/2"	2.7
5/8"	2.7
3/4"	2.8
7/8"	3.0
1"	3.0
1 1/8"	4.0
1 1/4"	4.2
1 1/2"	4.4
1 3/4"	4.9
2"	5.7

Table 3-12. Rock Drilling and Blasting

WORK ELEMENT DESCRIPTION	UNIT	MAN-HOURS PER UNIT
Drill Holes:		
Sinker Drill 2 1/2" dia. (Medium)	Lin. Ft.	0.2
Sinker Drill 2 1/2" dia. (Hard)	Lin. Ft.	0.3
Air Trac 2 1/2" dia. (Medium)	20 Lin. Ft.	2.4
Air Trac 2 1/2" dia. (Hard)	20 Lin. Ft.	3.6
Load and Shoot Holes	Each	3.0

NOTES:

1. Times may vary depending on type of rock, equipment and/or explosives.
2. Figures for blasting are for stick dynamite.

Table 3-13. Demolition and Removal

WORK ELEMENT DESCRIPTION	UNIT	MAN-HOURS PER UNIT
Concrete Foundations	Cu. Yd.	5
Concrete Walls	Cu. Yd.	6
Concrete Slabs on Grade, No Reinforcing	Cu. Yd.	4
Concrete Slabs on Grade, W/Wire Mesh Reinf.	Cu. Yd.	4
Concrete Slabs on Grade, W/Rबर and Mesh Reinf.	Cu. Yd.	6

NOTES:

1. Work includes removal of item and stacking or piling on site for removal at ground level.
3. For disposal up to five miles, use 1.5 man-hours per cubic yard for rubbish and rubble.
4. Concrete demolition is figured on using pneumatic tools with average crew of two tool operators and three to five laborers.
5. No allowance for salvage of materials (cleaning, pulling nails, etc.) is included in this table.

Table 3-14. Hand Excavation

WORK ELEMENT DESCRIPTION	UNIT	MAN-HOURS PER UNIT
General Excavation of Earth	1 CY	2.7
Trenches to 5' in Earth	1 CY	2.2
Post Holes, Small 3' Deep	1 Lin. Ft.	0.5
Fill Wheelbarrel/Georgia Buggys & Haul	1 CY	1.9
Spread Excess Earth	1 CY	0.9
Trim and Fine Grade	100 S.F.	1.9
Hand Compact W/Pneumatic	1 CY	0.8
Hand Compact W/Vibratory	1 CY	.2

NOTES:

1. When wheeling over 100' add 25% for each additional 40'.

Table 3-15. Clamshell (Hourly Production)

CLAMSHELL PRODUCTION - 90° SWING LOOSE CUBIC YARD PER HOUR (50 MINUTE HOUR)			
TYPE OF WORK	1/4 CY	1 1/4 CY	2 1/4 CY
Loose Sand/Gravel	40	70	105
PR Excavation	34	60	90

NOTES:

1. Figures are based on loose cu yds. use Table 4-19 to find the amount of bank cu yds (in-place)
2. Boom swing is for 90°

Table 3-16. Draglines (Hourly Production)

DRAGLINE PRODUCTION - 90° SWING BANK CUBIC YARDS PER HOUR (50 MINUTE HOUR)				
BUCKET SIZE	OPTIMUM LIGGING DEPTHS	CLASS OF MATERIAL		
		SAND/ GRAVEL	COMMON EARTH	DENSE CLAY
¾ CY	6'	70	58	50
1½ CY	7.4'	116	105	89
2½ CY	8.5'	164	147	127

Table 3-17. Erosion Control

WORK ELEMENT DESCRIPTION	UNIT	MAN-HOURS PER UNIT
Place: Jute Mesh, Plastic Netting, or Polypropylene Membrane	1000 S.Y.	14.3
Machine Place RIPRAP: Class "C" Material	1000 C.Y.	96.0
Hand Filling Voids in RIPRAP	1 S.Y.	1.6

Table 3-18. Rough Carpentry

WORK ELEMENT DESCRIPTION	UNIT	MAN-HOURS PER UNIT
Floor Joists, Sills, Girders and Blocking	100 Ft. Bd Meas.	4
Wall Framing-Studs, Plates and Bracing	100 Ft. Bd Meas.	4
Ceiling Joists	100 Ft. Bd Meas.	5
Roof Framing (Pitch Type) and Eave Blocking	100 Ft. Bd Meas.	6
Roof Framing (Flat Type)	100 Ft. Bd Meas.	4
Beams (Shaped and Dapped)	100 Ft. Bd Meas.	13
Beams (Exposed Framing)	100 Ft. Bd Meas.	10
Trusses, Light (Nailed)	100 Ft. Bd Meas.	7
Trusses, Heavy (Bolted)	100 Ft. Bd Meas.	10
Cross Bldgng. 2 x 3	50 Sets or 100 PCS	8
Metal Studs	100 Sq Ft of Surface	1
Fabricate and Install Rough Door Bucks (Masonry Walls)	Each Opening	3
Ceiling Stripping	100 Lin Ft	3
Furring on Concrete and Masonry Walls	100 Lin Ft	3.5
Wood Plaster Grounds on Masonry Walls	100 Lin Ft	6
Wood Fences	100 Sq Ft	8

NOTES:

1. Rough carpentry includes the work of measuring, cutting, and installing wood framing, floor joists, sills, cross bridging, wall framing plates, door bucks, roof framing, and rafters. All work in connection with installing wall and roof sheathing and siding is also included.

Table 3-19. Placing Concrete

WORK ELEMENT DESCRIPTION	MAN-HOURS PER UNIT				
	UNIT	DIRECT FROM CHUTE	WHEELED	PUMPED	CRANE AND BUCKET
PLACE FOOTINGS, FOUNDATIONS					
Grade Beams	Cu. Yd.	1	2	1.5	1.5
Slabs on Grade	Cu. Yd.	1.5	3	2	2.5
Walls to 10' High	Cu. Yd.	---	---	1.68	2.24
Columns	Cu. Yd.	---	---	1.68	2.24
Suspended Slabs	Cu. Yd.	---	---	1.68	2.24
Beams and Girders	Cu. Yd.	---	---	1.68	2.24

Table 3-20. Mixing Concrete

WORK ELEMENT DESCRIPTION	UNIT	MAN-HOURS PER UNIT
HAND MIXING ON SITE		
2 Boards or Boats	Cu Yd	3.2
Machine Mixing On Site (16 S Mixer)	Cu Yd	1.6
Transit Mix Truck	Cu Yd	0.56

NOTES:

- 1 Hand mixing tables are based on enough men to keep a smooth constant flow of materials approximately eight men. Men-hour figure (hand) does not include placing, maximum output about 20 Cu Yds per day.
- 2 Hand mixing using two boards eliminates waiting for a batch to be mixed before dry charging the mixing board, as the mixer alternates boards. With twelve men the maximum output is about 26 Cu Yds per day.
- 3 Warm weather (90 to 100 degrees) will slow mixing time, and add 0.5 man-hours per cu yd.
- 4 Labor to charge a 16S mixer can be reduced by the use of a small front end loader, but at least one man must remain on each aggregate stock pile to monitor bucket loading.
- 5 Transit mix man-hours are based on using four trucks, average haul of five miles, and four men operating a dry cement batching plant (Ross or equal).

Table 3-21. Production Efficiency Guide Chart

		LOW PRODUCTION	AVERAGE PRODUCTION	HIGH PRODUCTION							
PRODUCTION ELEMENTS (PERCENT)											
		25	35	45	55	65	75	85	90	95	100
		FORESEEN CONDITIONS									
1.	Workload	Const. requirement high; misc. overhead high.			Const. requirement normal; misc. overhead normal.			Const. requirement low; misc. overhead low.			
2.	Site Area	Cramped working area; no area for material storage; work restricted to design; poor job layout.			Work area limited slightly; partial material storage; some variation from design; average job layout.			Large work area; adequate material storage; wide latitude from design; good job layout.			
3.	Labor	Poorly trained; low strength; low morale; high sick call.			Average trained; normal strength; fair morale; normal sick call.			Highly trained; over strength; high morale; low sick call.			
4.	Supervision	Poor management; poorly trained personnel; low strength.			Average management; average trained personnel; normal strength.			Efficient management; highly trained personnel; over strength.			
5.	Job Conditions	High quality work required; unfavorable site materials; short time operations; insect annoyance high.			Average work required; average site materials; reasonable operation time; insect annoyance normal.			Passable work required; good site materials; long time operation; no insect annoyance.			
6.	Weather	Abnormal rain; abnormal heat; abnormal cold.			Moderate rain; moderate heat; moderate cold.			Some rain; occasional heat; occasional cold.			
7.	Equipment	Improper job application; equipment in poor condition; repair and maintenance inadequate.			Fair job application; equipment in average condition; repair and maintenance average.			Efficient job application; equipment in good condition; efficient repair and maintenance.			
8.	Tactical and Logistical	Slow supply delivery; frequent tactical delays.			Normal supply delivery; occasional tactical delays.			Prompt supply delivery; no tactical delays.			

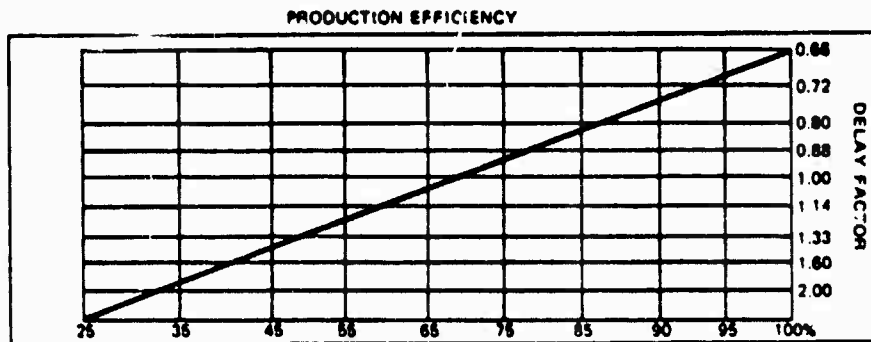

Figure 3-1. Production efficiency graph

because of the numerous variables involved. The types and amount of materials used and the time taken for repair will be determined by the location, the number of qualified personnel available, operational requirements, and many other factors. A reasonable cost estimate cannot be given that would accurately apply to the assumed scenario.

3.7 Tools and Materials Estimating

Whenever repairs are attempted, it is always desirable to have conventional tools and repair materials. However, during expedient repairs it is not always possible to have the best tools and materials for the job. Tools that can be used for multiple purposes would assist in filling the voids. The required tools will vary depending on the type of work to be performed and what has been provided in the Table of Equipment. Examples of tools that may be useful are:

- hydraulic jacks
- cutting and welding machines
- air compressors
- pulleys and blocks
- surface support craft and drive motors
- concrete mixers
- chain saws
- jackhammers
- diver tools (band saw, rock drill, impact wrench)
- multi-purpose land vehicles
- powder-actuated stud driving guns
- generators
- cranes and forklifts
- bulldozers

In addition to the materials mentioned in each particular chapter the following materials may be useful for repairs:

- cement, clean sand, and aggregate
- epoxy, grouts, and glues
- plywood, lumber, piles, and timber

- steel shapes, plates, and reinforcing rods
- silicone rubber
- canvas
- explosives, primers, detonating cord
- chain, wire rope, manila line, synthetic rope

3.8 Repair Versus Replace Decisions

The decision on whether to repair or replace is dependent on numerous variables and will have to be assessed on a case by case basis. Several questions can be asked that will assist in evaluating whether the pile should be replaced. Among these are:

1. Is the pile reparable? For example, is it split lengthwise, has it been extensively damaged by marine borers, is it severely splintered?
2. Are materials readily available to permit pile replacement?
3. Is the pile stub accessible and can it be removed with the available equipment?
4. Are a pile driver and properly trained operator available to drive the replacement pile?
5. Will the repair considered withstand the anticipated load?
6. Do operational requirements permit the time needed for pile replacement?

4.0 Demolition and Rubble Removal

Before any underwater assessment of damage and the determination of required repairs can be made on a damaged site, it will have to have damaged material or rubble removed to permit access to the damaged area by the personnel who are doing the assessment. This operation is one of the most hazardous steps in returning damaged facilities to operational status because of the inherent instability of the damaged facilities and the rubble on the sea floor and in the water column. Moving rubble may cause further instability and even collapse, so diver personnel must be well clear of the site before any movement is attempted. This report assumes that the personnel assigned to do the work are trained and have the proper equipment/material to do the job. The data that follow provide information concerning demolition and rubble removal methods that should be considered by onsite personnel.

4.1 Improvised Explosives

Explosives are used extensively in demolition and rubble removal. In cases where sufficient conventional explosives are not available to do the job, it may be necessary to make and use explosives from other materials on hand. The use of improvised explosives is very hazardous and requires that the people

who use them be trained in the handling and use of conventional explosives. Besides being qualified to use conventional explosives, individuals should be familiar with Army Field Manual FM 5-25, Explosives and Demolitions, Appendix C, Expedient Demolitions.

4.2 Demolition Techniques

Demolition techniques will vary depending on the type of material to be demolished and the equipment on hand to do the demolition. It could vary from the basics of using a crow bar and hand pick-up to the more sophisticated methods including controlled blasting and the use of motorized cranes. Regardless of the type of material to be demolished, the principal concern in demolition should be to get the material to be removed to as small a size as necessary to permit movement by the equipment on hand. Chapter 3, Calculation and Placement of Charges, of FM 5-25 presents extensive data on proper placement methods to optimize the use of explosives.

4.2.1 Wood

Wood is the easiest material to break up into manageable pieces because of its relative lack of strength as compared to steel or concrete. Controlled blasting, sawing, and boring through the wood and bending it at the bore holes by applying force to it, the use of hydraulic shears and even cutting by an axe are all potential methods to be considered in demolition of wood structures and rubble. The decision regarding the best method must be made by onsite personnel after they have seen what must be removed and know what tools are available.

4.2.2 Concrete

Concrete is the most difficult material to break up into manageable pieces because it is frequently reinforced internally with reinforcing steel and the concrete must be removed first before the steel can be cut. Concrete can absorb a great deal of energy if the energy is not directed to very small areas. The best way to break up concrete is through controlled blasting. The use of powered abrasive cutting wheels is also effective when breaking up concrete. When cutting concrete with abrasive wheels, care must be taken not to cock the wheel in the kerf being cut because the wheels are brittle and will shatter. High pressure water jet tools are also useful in removing concrete but they are not effective in cutting reinforcing steel inside the concrete. Concrete can also be cut very effectively with thermal lances, sold commercially under the name BROCO Ultrathermic Burning Bars. They are effective with the removal of the concrete and cutting the internal reinforcing steel.

4.2.3 Steel

Steel is most effectively cut by the use of the oxygen arc cutting process, or an ultrathermic electrode cutting, sold commercially under the name BROCO Ultrathermic Burning Bars. The method is easy to learn, cutting is quick, and expedient electrodes can be made with materials frequently found in the field. The method does require that a BROCO torch be available. Details of fabrication of expedient electrodes are included as Appendix A. Additional, less effective methods of cutting steel are possible using shielded metal arc and

MAPP gas equipment and techniques. Lacking this equipment, controlled blasting, as mentioned earlier, and abrasive disk cutting wheels may be used with success, although it takes longer to use these methods.

4.2.4 Ordnance Removal

The removal of unexpended ordnance is an extremely hazardous operation and should be attempted only by trained Explosive Ordnance Demolitions (EOD) personnel. A complete survey by EOD personnel is recommended prior to beginning any demolition or rubble removal. If unexpended ordnance is located after work has begun, all personnel should clear the area and await the specialized assistance of EOD personnel. On occasions, EOD personnel may not be available, and repairs must proceed. If that is the case, demolition and rubble removal should take place very carefully, and if unexpended ordnance is located, it should be destroyed in place by use of controlled blasting. The details of ordnance disposal are too complex to treat in detail but are covered in detail in Headquarters, Department of the Army Technical Manual TM 9-1375-213-12 and FM 9-15.

4.3 Rubble Clearance from Decking Interface

It is essential that the interface between the decking and the support structure be prepared to the point that loads will be evenly transmitted. Broken or damaged material must be removed and care must be taken to keep from damaging adjacent facilities when preparing the interface for connection. The use of controlled blasting is not a preferred method to prepare the interface. Other techniques discussed in preceding demolition paragraphs can be used if care is exercised.

4.4 Rubble Clearance from Piling

Rubble clearance from pilings can be accomplished using the methods discussed in prior demolitions paragraphs. Again, care should be exercised to avoid additional damage to otherwise undamaged pilings. The removal of marine organisms in preparation for repairs to damaged piles can be done in a variety of ways. One of the most effective methods is high pressure water jet tools that blast the marine growth off the pilings without causing damage to the piling. This method requires specialized high pressure water compressors, hoses and tools not presently in Army inventory. Other methods such as grinding tools and the use of chipping hammers are effective but much slower.

Rubble removal from the base of piles can also be accomplished through the use of diver lift bags and float balloons. Among the types of lift devices are the open-bottom lift bag, the closed-bottom lift bag, and the variable-buoyancy lift bag. The open-bottom lift bags work by admitting air from the bottom of the bag to make it ascend and venting air through a valve in the top of the bag to slow the ascent. Lift bags are shown in Figure 4-1. Closed-bottom lift bags have an air inlet fitting for inflation and usually have an over pressure relief valve to prevent rupture from increasing air pressure as the lift bags ascend. Buoyancy of closed-bottom lift bags is difficult to control because the bags only have an over pressure valve, and the pressure in the bag must be excessive to actuate this valve. This sort of actuation means that the bag must either be full or that the air in it would increase in

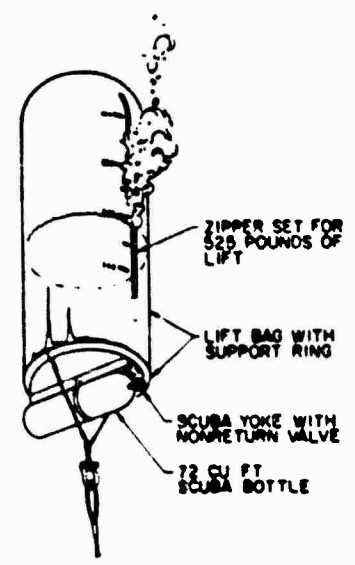
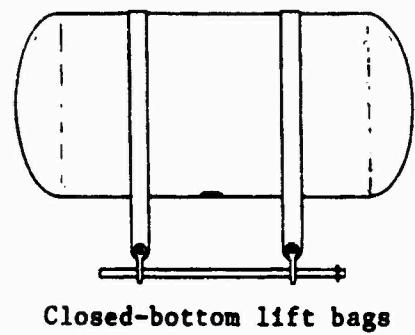
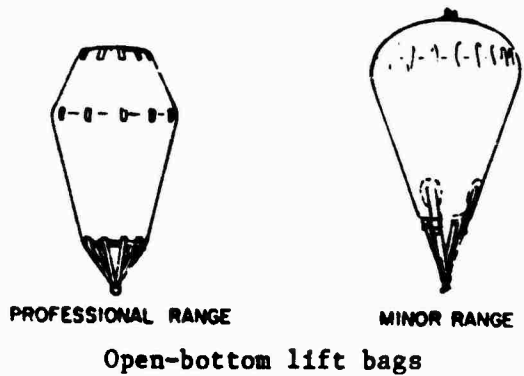

Variable-buoyancy lift bag

Figure 4-1. Types of lift bags

volume, thereby only having the capability to maintain or increase the buoyancy. If excessive buoyancy or a float balloon is desired, the closed-bottom bag is well suited. Variable-buoyancy lift bags have the capability of pre-determining the amount of weight to be lifted. To do this a vertical zipper on the bag is opened or closed enabling only a certain volume of air to be contained in the bag. When ascending and the air expands to a volume that would exceed the desired lifting capability, the excess air will spill out at the bottom of the zipper and thus be self-limiting. The variable-buoyancy bag has the benefit of having a fairly controlled ascent with moderate payloads. One problem with this type of bag is that during descent the bag is very unstable and requires air to be continuously added to maintain the displaced volume.

If manufactured lift bags are not available, they can be substituted by almost any container that can be submerged and filled with air. In general, any can, drum, buoy, or tank may be used as an expedient lift device. One example of an object that can be used is a jerry can. When using jerry cans the buoyancy can be determined by multiplying the gallon capacity of the can by 8.5, multiplying this number by the number of cans used, and then subtracting the cumulative weight of all the cans. See Table 4-1 for buoyancy of multiple jerry cans. The cans can be attached and assembled in one of the configurations as shown in Figure 4-2. The preferred method is the first, tack welding metal straps from one can to another. NOTE: Care must be taken when welding containers that have held volatile substances. The second method shown is to use banding straps. The banding straps are run vertically and horizontally around the cans being careful to assure that the bands go through the jerry can handles. The third method treats the cans as individual lift devices but uses their cumulative effect for lifting. Figure 4-3 shows the best fabrication configurations. After the cans have been fabricated and lines attached, they can be used. Scuba tanks or an air hose from the surface is used to slowly fill the cans. The outboard cans are filled first to stabilize the lifting device and then the inboard cans are filled until the object breaks free from the bottom.

Table 4-1. Net Buoyancy for 5-Gallon Cans

No. of cans	1	2	3	4	6	8
Net buoyancy (lb)	33	66	99	132	192	264

4.5 Personnel and Diver Safety

As stated earlier, demolition and rubble removal is one of the most hazardous steps in returning damaged facilities to an operational condition. The structural instability and unknown conditions present at a damaged site dictate that this work proceed cautiously. A safety observer should be assigned to be alert for safety problems. The observer should report directly to the onsite supervisor and should have no other assigned responsibilities. The number of personnel and the amount of equipment at the repair site must be at an absolute minimum because of the unknown structural conditions.

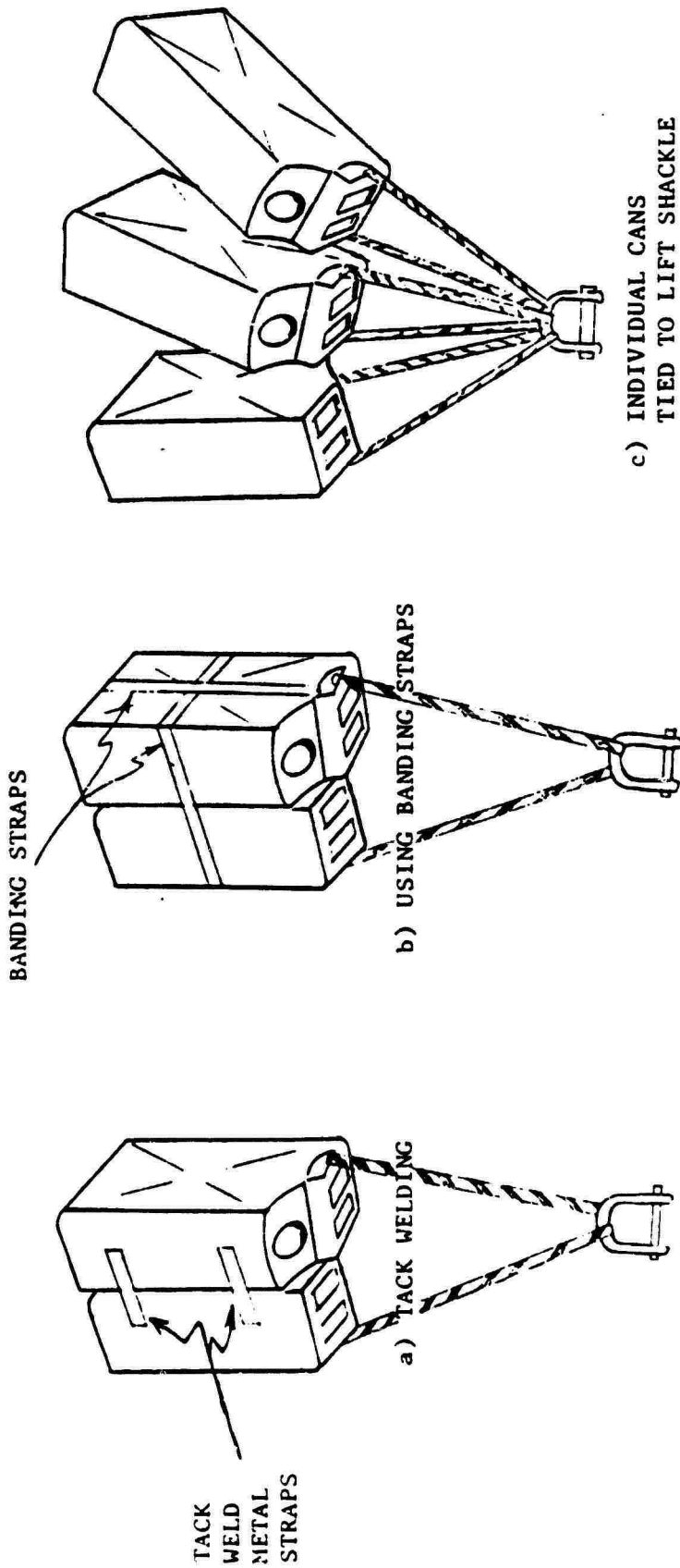
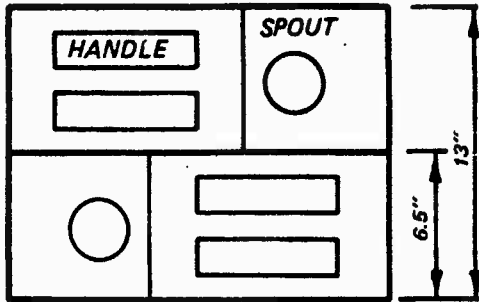
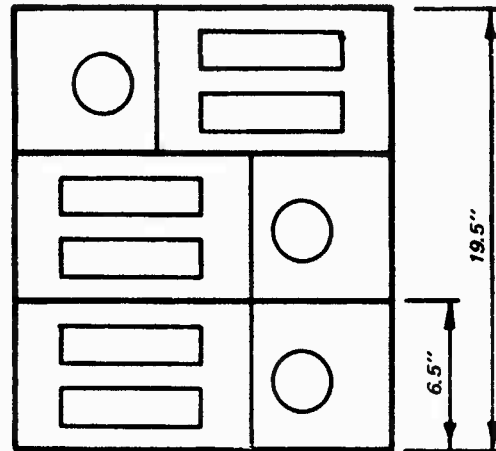

Figure 4-2. Methods for fastening jerry cans



2 - CANS



3 - CANS

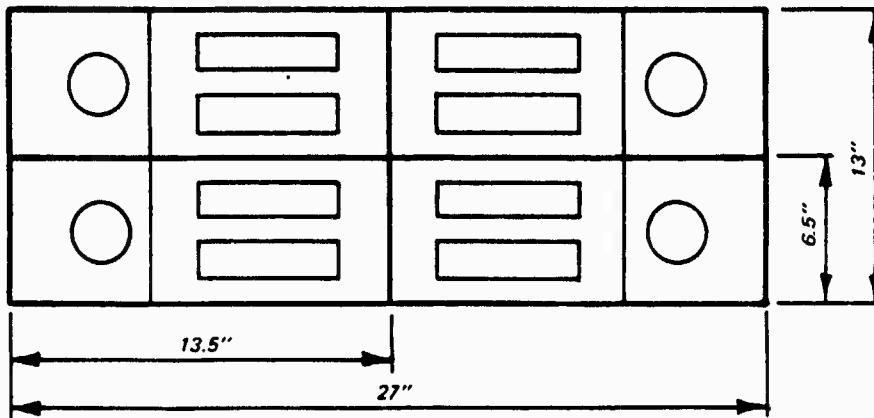

4 - CANS

Figure 4-3. Can orientation (bottom view)

Damaged structures may have excessive stress loads that can be released when the structure or rubble is moved. It is important that divers be aware of this possibility, and before any lifting or moving loads are applied, the diver should be well clear of the structure. It is preferable to have the diver out of the water prior to applying loads or attempting to move rubble.

Besides normal diving safety practice, divers should be extremely careful when working around damaged facilities, because of sharp edges of broken material and the possibility of further failure of the structure. Underwater conditions are most likely to have very limited visibility which further complicates the procedures. Divers should be tethered and tended at all times. They should also have communications to the surface. Prior to putting divers in the water, the diving supervisor should personally assure that all utility services have been turned off to the site. Personal injury and even death could occur through inadvertent activation of utility services while the diver is in the water.

4.6 Site Preparation

After the rubble has been removed and the repairs have been decided upon, site preparation is necessary. When foundations are required, the sea floor may need to be cleared of mud, sand, or silt. Large amounts of material are removed most efficiently with heavy duty dredge systems that are most likely not available. Another method is the use of cranes with dragline equipment installed. If this equipment is not available, then the use of airlift and underwater dredge systems may provide the solution.

4.6.1 Airlift

An airlift can be used underwater to provide the controlled removal of seabed material. The airlift works on a differential density principle. Air is introduced into the lower end of a partially submerged pipe. When air bubbles combine with the water in the pipe, a mixture that is less dense (lighter) than the water outside the pipe forms. The lower density mixture in the pipe rises, causing a suction at the inlet. The amount of material lifted will depend upon the size of the airlift, submerged depth of the pipe, air pressure and volume used, and the discharge head.

As shown in Figure 4-4, the airlift consists of a discharge pipe and a foot piece or air chamber powered by a surface compressor. The size of the discharge pipe can range from 3 to 12 in. in diameter, depending on the work to be done (see Table 4-2). The air chamber should be located 20 to 30 in. from the intake end of the pipe and should be fitted with a control valve that cannot be opened or closed accidentally. A handle attached to the lower end will make it easier for the diver to use. It is sometimes necessary to add weight to the lower end to help keep the intake on the bottom.

Operation of the airlift simply involves turning on the air compressor and control valve and then submerging the intake end (foot piece) into the seabed material. The seabed material starts to lift almost as soon as the low-density fluid in the discharge pipe rises. Experimentation is usually required to determine the volume of air necessary for maximum efficiency. The air pressure supplied is relatively unimportant, but it must be at least

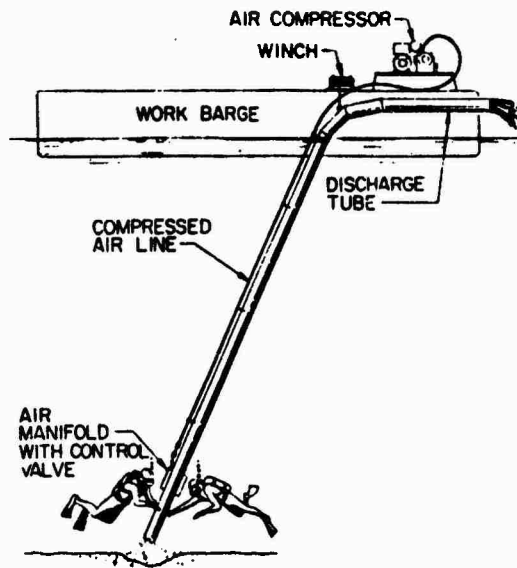

Figure 4-4. Airlift

Table 4-2. Selection Guide for Airlift Discharge Pipe and Air Line

Diameter of Discharge Pipe in.	Diameter of Compressed Air Line in.	Discharge Rate gpm	Air cfm
3	0.50	50 - 75	15 - 40
4	0.75	90 - 150	20 - 65
6	1.25	210 - 450	50 - 200
10	2.00	600 - 900	150 - 400
12	2.00	900 - 1000	200 - 550

greater than the pressure at the depth of water in which the excavation is being performed. The airlift can be from 10 to 70 ft long, but it is relatively inefficient in lengths of less than 30 ft. It can be used in water depths of 25 to 75 ft. The discharge end of the airlift should be kept as close to the surface as possible to avoid reducing efficiency.

The airlift has the disadvantage of discharging the lifted material relatively close to the intake point. This may result in some of the material settling back into the excavated area. The discharge should be positioned downcurrent to allow the prevailing currents to carry the material away. The divers operating the airlift should use caution around the inlet to avoid the effect of suction and should stay clear of the area under the discharge end where heavy objects will be ejected.

4.6.2 Dredging

Underwater dredging is a useful technique for moving large quantities of soft seabed material where the water is too shallow for an airlift to be effective and where the material does not have to be lifted too far above the intake point. Figure 4-5 illustrates a typical underwater dredge arrangement. It consists of a tube or pipe with a 30 deg bend near the intake end. At the center of the bend a water jet is connected. The water jet is aimed towards the discharge along the center line of the main pipe. The jet moves the water in the pipe and creates a suction at the intake. The height of the lift attained depends on the size of the pipe and the output of the pump.

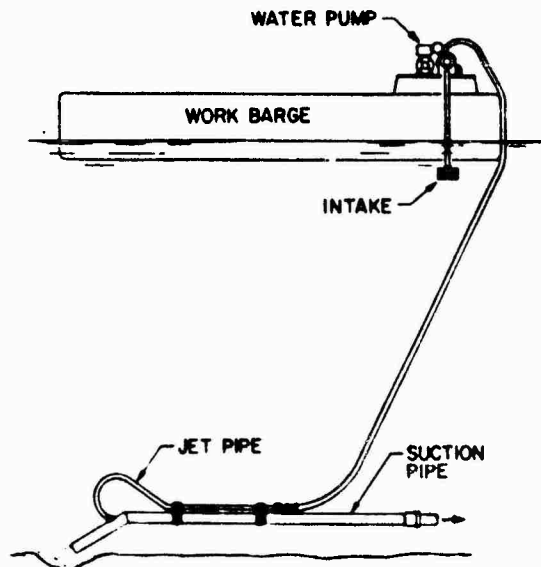

Figure 4-5. Underwater dredge

A 200 gpm pump with a 6 in. pipe will lift as high as 60 ft above the seabed. When operating only a few feet above the seabed this same system can move as much as 10 cu yd of loose gravel, mud, and sand per hour. Table 4-3 lists typical suction pipe, jet pipe, and pump sizes.

It is preferable for the suction pipe to be lightweight for ease of handling, and plastic pipe is recommended. A diver can hold the suction end in place

and reposition it simply by swimming to a new position. Reaction forces are low, and buoyancy is not normally required.

Excavation methods and factors for suitability are summarized in Table 4-4.

Table 4-3. Selection Guide for Underwater Dredge, Suction Pipe, Jet Pipe, and Pump

Diameter of Suction Pipe in.	Diameter of Jet Pipe in.	Minimum Pump Output gpm
2	1	55
3	1	100
4	1-1/2	125
6	1-1/2	300
8	3	500

Table 4-4. Suitability of Underwater Excavation Devices

Excavation Factor	Excavation Method			
	Air Lift	Jet	Dredge	Blasting
Type of seabed material	mud, sand, silt, clay, cobbles	mud, sand, silt, clay	mud, sand, silt, clay	coral, rock
Water depth	25 to 75 ft	unlimited	unlimited	unlimited
Horizontal distance material moved	short	short	short to long	short
Vertical distance material moved	short to long	short	short to medium	short
Quantity of material excavated	small to large	small to medium	small to medium	small to large
Local current	not required	required	not required	not required
Topside equipment required	compressor	pump	pump	hydraulic power unit
Shipping space/weight	large	small	medium	large

5.0 Transportation and Erection of Materials

5.1 Lifting Techniques

In order to facilitate an expedient repair it may be necessary to transport repair materials from the place they are found to the site of repair. Any available mode of transportation should be considered for expediting the transfer of materials but there are those more suited to the task than others. Due to the types of vehicles found in a container port, it is very likely that a straddle lift, forklift, and tractor-trailers could be used for materials transportation. The repair materials could be loaded into a container and the straddle lift or tractor-trailer would take it to the repair location. The forklift could be used for materials transport or could be used in a conventional manner and assist in loading the tractor-trailer or positioning materials for the straddle lift.

Once the materials are at the site of the repair, they can be lifted into position by one of the vehicles or, if no lifting type of vehicle is available, an expedient lifting device can be used. The types of lifting devices that can be expediently constructed are the gin pole, shears, tripod, or the expedient winch.

The information contained in this section should be considered complimentary to the Department of the Army Technical Manual TM 5-725. This Army Technical Manual is referenced in the following sections where specific information is needed to fully describe the fabrication and operation of these materials transportation and erection devices.

5.1.1 Gin Pole

The gin pole device can be rigged for use in lifting or repositioning a load either onshore or nearshore. The gin pole can raise a load vertically or drag it horizontally toward the base of the pole in preparation for a vertical lift. The gin pole consists of a vertical spar guyed at the top to maintain it in a vertical or nearly vertical position. The pole is also equipped with a suitable hoisting tackle. Figure 5-1 contains a diagram of a gin pole.

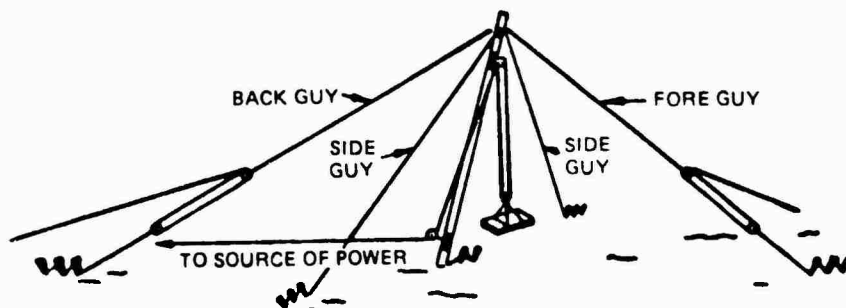

Figure 5-1. Gin pole ready for operation

5.1.1.1 Materials Selection and Sizing

The vertical spar and guylines must be properly sized prior to gin pole fabrication to ensure they will be strong enough to accomplish the required lifting.

The following 'Rules of Thumb' apply:

1. Spar length = 5 ft for each inch of thickness for timber spars.
2. Guyline length = three to four times the spar length.
3. Use a minimum of four guylines evenly spaced around the spar.

5.1.1.2 Vertical Spar and Guylines

The vertical spar may be made of timber, wide flange steel beam section, railroad rail, or similar members of sufficient strength to support the load. Wire rope is the recommended material for guyline fabrication; however fiber rope or other available material may be used.

Prior to materials selection, several aspects must be examined. Among these are:

1. Determining where the gin pole device is to be located, keeping the location close to that of the object to be moved.
2. Measuring the distance from the vertical spar location to the object.
3. Estimating the weight of the object to be moved by determining the material from which it is made and its size.
4. Surveying possible available materials for use as the vertical spar.

After materials in the area have been surveyed, the required size of the spar to do the job must be determined. Table 5-1 can be used to determine the spar size required to safely lift the weight of the object. The value for the safe lifting load in Table 5-1 must be greater than the weight of the object.

If timber materials are not available, loads up to 25,000 lb may be lifted with the vertical spar of a gin pole device constructed of various steel shapes. These shapes include Schedule 40 pipe, wide-flange section steel beams, rectangular tubing, and steel rail. The minimum required sizes to lift up to 25,000 lb are shown in Table 5-2.

NOTE: Splicing of these members is not recommended. The maximum allowable length for steel vertical spars is 30 ft.

Table 5-1. Safe Lifting Load in Pounds for a Given Length of Timber*

Timber Size in.	20 ft	25 ft	30 ft	40 ft	50 ft	60 ft
6 diam	5,000	3,000	2,000	--	--	--
8 diam	--	11,000	8,000	5,000	3,000	--
10 diam	31,000	24,000	16,000	9,000	6,000	--
12 diam	--	--	31,000	19,000	12,000	9,000
6 x 6	6,000	4,000	3,000	--	--	--
8 x 8	--	14,000	10,000	6,000	4,000	--
10 x 10	40,000	30,000	20,000	12,000	8,000	--
12 x 12	--	--	40,000	24,000	16,000	12,000

* Applicable materials include: spruce, douglas fir, pine, mahogany, oak, and ash.

Table 5-2. Minimum Required Sizes of Steel Shapes for Lifting Up to 25,000 Pounds

Steel Shape	Minimum Size
Schedule 40 pipe	8 in. diam.
Steel beam - wide flange section	8 in. x 28 lb/ft
Rectangular tubing	8 x 6 x 3/8 in. wall thickness
Steel rail	105 lb/yd

5.1.1.3 Guyline Sizing

To properly support the expedient lifting device, it is necessary to have support lines. These lines must also be capable of maneuvering the object to the desired location. The length and diameter of the lines will be directly related to the length of the vertical spar and the weight of the object to be lifted. Tables 5-3 and 5-4 can be used for proper line size determination.

Table 5-3. Vertical Spar and Guyline Sizing

Maximum Spar Length ft	Minimum Guyline ft	Approximate Distance From Spar to Guyline ft	Perpendicular Distance From Spar to Rear Guyline ft
20	60	57	18
25	75	71	23
30	90	85	28
35	105	99	33
40	120	113	39
50	150	141	48
60	180	170	55
70	210	198	66
80	240	226	76

Table 5-4. Guyline Material Selection

Diameter in.	Safe Working Load		
	Manila lb	Nylon lb	Wire Rope lb
3/8	270	700	2,344
1/2	530	1,240	4,120
5/8	880	2,100	6,360
3/4	1,080	2,800	9,080
7/8	1,540	4,000	12,280
1	1,800	4,800	15,880
1-1/8	2,400	6,400	19,920
1-1/4	2,700	7,300	24,400
1-3/8	--	--	29,240
1-1/2	3,700	10,200	34,480
1-3/4	5,300	15,500	--
2	6,200	18,000	--
2-1/4	8,200	25,000	--
2-1/2	9,300	27,600	--
3	12,800	39,000	--

5.1.1.4 Rigging

The gin pole is rigged as shown in Figures 5-1 and 5-2. Call-outs in the figure will identify the required rigging. Step-by-step procedures for rigging a gin pole are shown in TM 5-725.

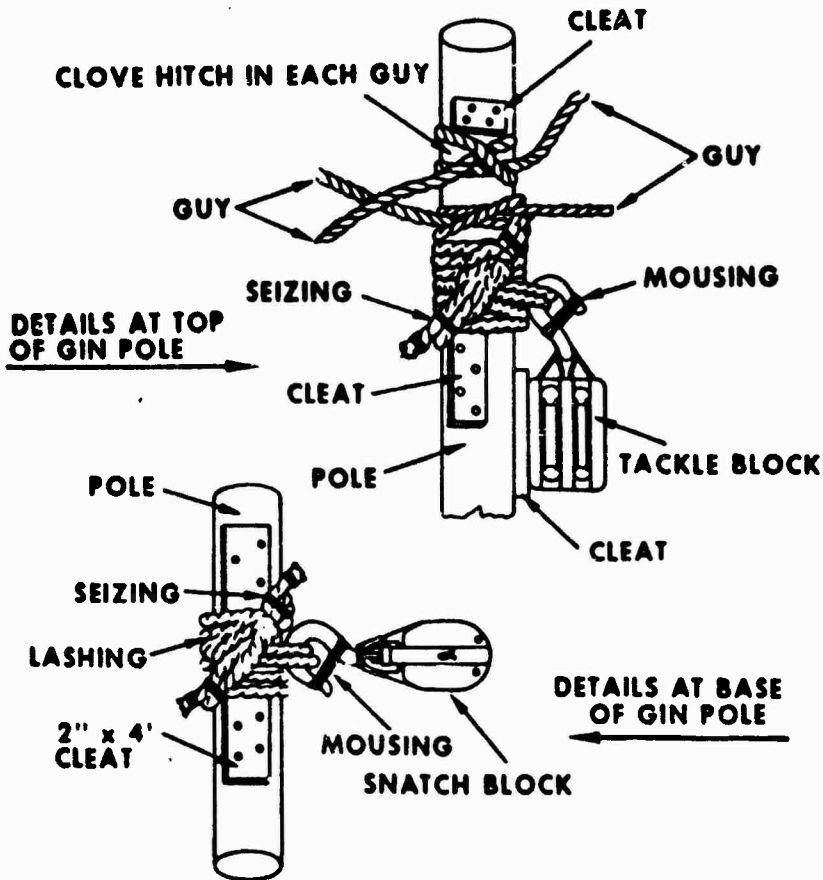

Figure 5-2. Lashing for gin pole

5.1.2 Shears

Shears consist of two legs that have been lashed or secured at the top. It is quickly assembled, erected, and is particularly suited for lifting heavy machinery or other bulky loads. The proper leg size can be determined by using Table 5-1. A shear is formed by crossing two members at their tops and suspending a hoisting tackle from their intersection. The shears require two guys to hold it in position and is adapted to working at an inclination.

5.1.2.1 Rigging

As shown in Figure 5-3, a shear is fastened together at the top by lashing with rope that is about 1 in. in diameter. Tables 5-3 and 5-4 will assist in guylines selection. Multiple turns are taken around both legs for fastening. The turns should be wrapped tightly and without kinks for optimum performance. The specific details of construction can be examined in TM 5-725.

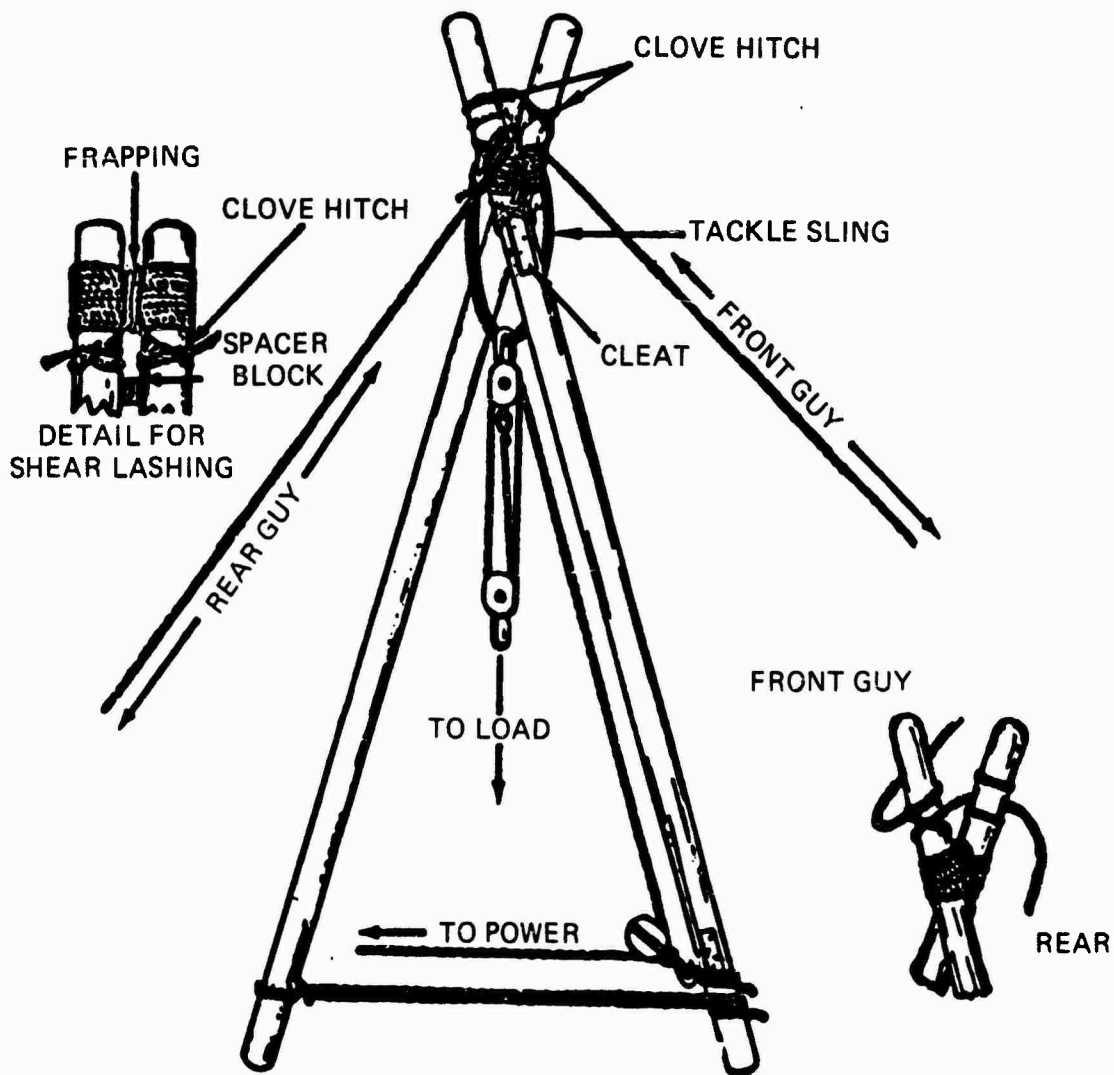

Figure 5-3. Lashing for shears

5.1.2.2 Erecting

Erecting the shears is done by first digging two holes at the points where the legs are to stand and placing the butts of the legs into the holes or anchoring the legs to a hard surface to prevent them from slipping during erection and operation. Attach a set of reeved blocks to the top of the shears and then, depending on their size, have several men "walk" them up by hand until the rear guy can assist. Larger shears may require the assistance of a pulley system to help in raising. Once the shears have been raised the legs should be kept from spreading by connecting them with rope, chain, or boards.

5.1.3 Tripod

A tripod consists of three legs lashed or secured at the top as shown in Figure 5-4. The primary advantage of the tripod over other rigging installations is its stability and that it requires no guidelines to hold it in place. It also is capable of a load capacity that is approximately one and one-half

times that of shears made of the same size material. As with shears, a member size can be determined by assessing the weight to be lifted, and then by using Table 5-1.

5.1.3.1 Rigging

As shown in Figure 5-5, there are two methods of lashing a tripod, either of which is suitable provided that strong lashing material is used. Typical material used for lashing is fiber rope, wire rope, or chain. Metal rings joined with short chain sections and large enough to slip over the top of the tripod legs also can be used. The specific procedure for tripod construction is shown in TM 5-725.

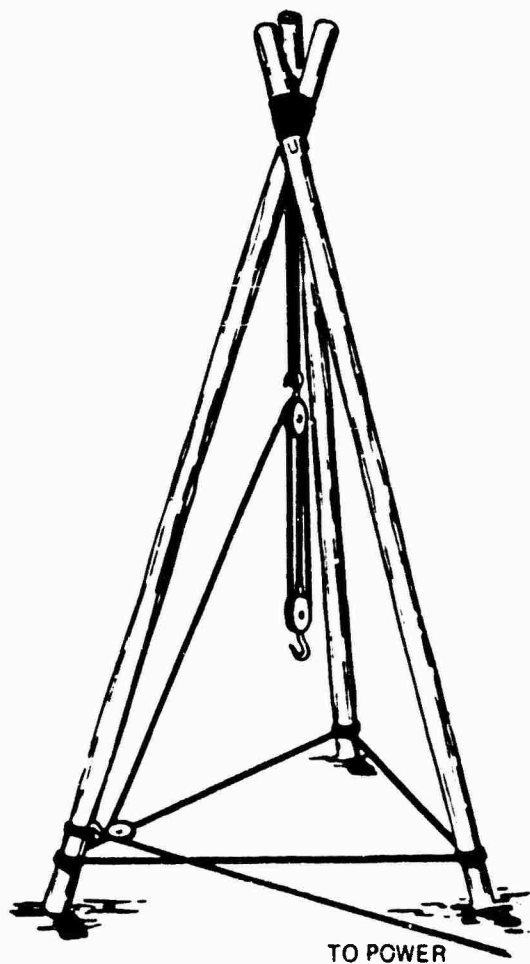

Figure 5-4. Tripod assembled for use

SPACING BETWEEN SPARS SHOULD BE ABOUT ONE-HALF THE DIAMETER OF THE SPARS

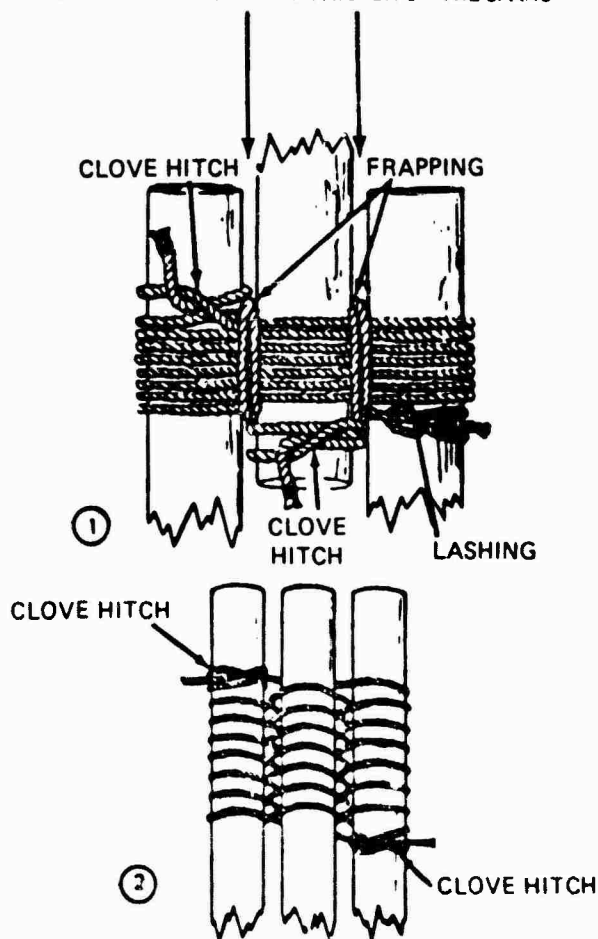

Figure 5-5. Lashing for a tripod

5.1.3.2 Erecting

An average size tripod can be erected in position by about eight men with no additional assistance by equipment. Any additional equipment will help in reducing the number of personnel and construction time. When the tripod is fully erected, the legs should be positioned such that they are equidistant from each other. The spread of the legs should not be less than one-half nor more than two-thirds of the length of one leg. When the legs are in their final position, a rope or chain lashing should be placed between them to keep them from shifting.

5.2 Expedient Winch

When winches or blocks and tackle are not available, and weights need to be moved, a makeshift winch can be created by the use of the drive wheels on trucks as shown in Figure 5-6. While this is a dangerous operation, it may be the only way to obtain the pulling power needed.

The truck's drive wheels are jacked off the ground, and the truck frame is blocked up. All of the other wheels are chocked and the truck anchored in such manner that the pulling line and the truck anchor are preferably in a straight line or at the very least, parallel. For safety's sake, the anchor should be strong enough to take the same load that the pulling line will see.

The pulling line is attached to the load and either passes through sheaves to vary the direction of pull or is brought to the truck and wrapped directly around one of the tires on the drive axle. The pulling line should be lead onto the tire at the bottom and the bitter end of the pulling line should come off the top in order to give the most control to the person handling the bitter end.

At least two wraps around the tire should be made. If the truck has dual wheels, it may be possible to wrap the pulling line around the axle between the dual wheels, but care must be taken to keep the pulling line from overlaying itself and possibly binding up, jamming, and locking itself when the load is applied.

The engine is started slowly with the transmission and then power is applied. Both the driver and line handler should be in visual contact with each other in order to coordinate this action. As the drive wheel begins rotating, slack will be taken up and tension will increase on the pulling line. As the load increases, power must also be increased, but it must be done very slowly or the pulling line will break due to excessive loading, or it may slip and the pulling will be stopped. During this operation the blocking on the truck frame should be watched to ensure that it is not moving. All nonparticipating personnel should be kept out of the area in order to avoid unnecessary injury if the line parts or the truck falls off the blocks.

The load capacity for this method will vary depending on the type of truck being used. Lift capability must be determined in the field by trial and error.

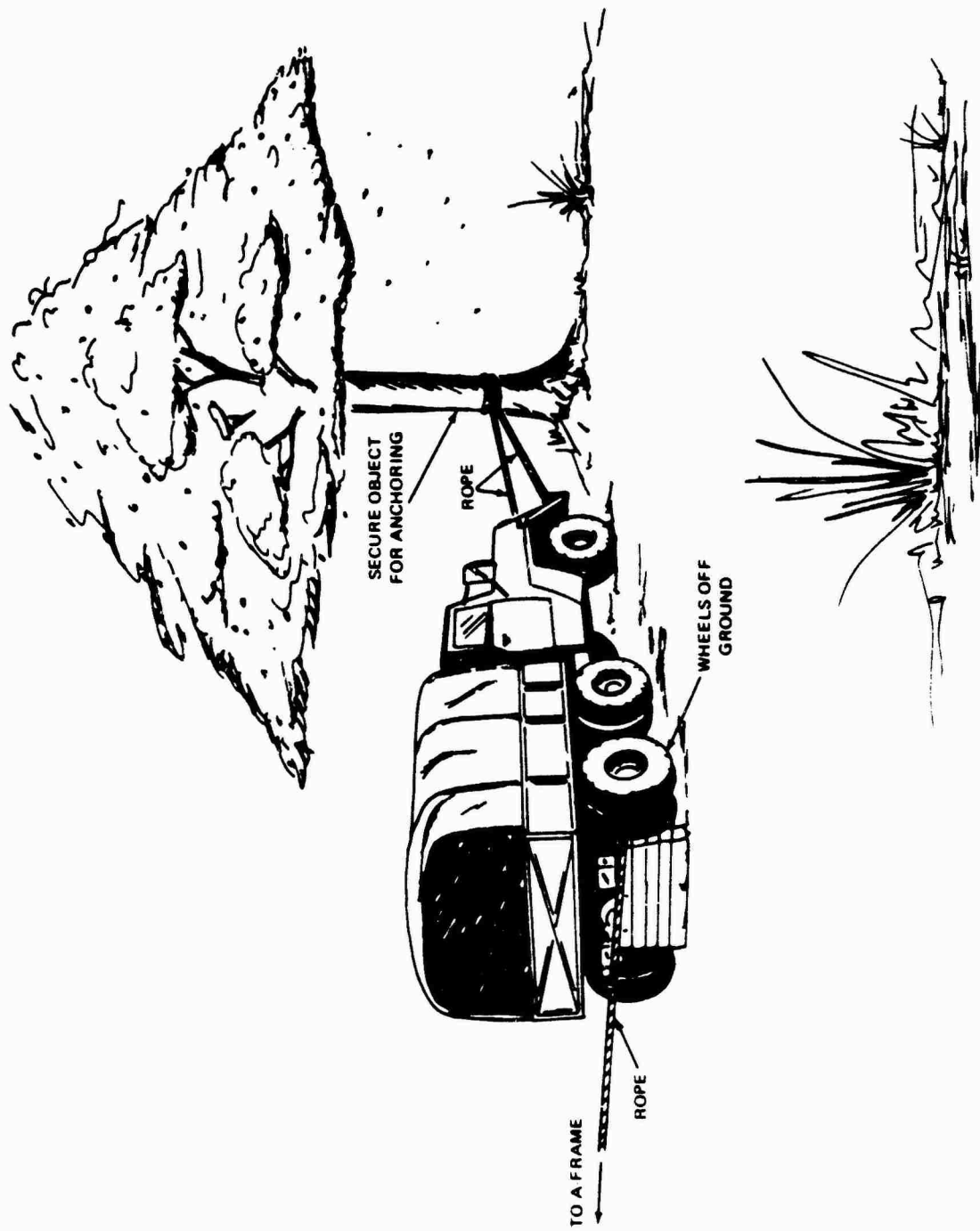

Figure 5-6. Expedient winch

6.0 Repair Concepts for Foundations

An expedient foundation is a fabricated base, enabling the loads from the pile to be transferred to the ocean floor. This base is constructed such that the pile loads can be evenly distributed over a large area. The area is dependant upon the bearing capacity of the soil and the loads imposed. A worst case soil bearing capacity of 2,000 lb/sq ft is assumed in this report.

These expedient pile foundations are to be used where no previous pile existed, or where the base of the pile to be repaired cannot be used due to extreme damage. All of the fabricated foundation concepts can be completely assembled before being lowered to the ocean floor. This drastically expedites the repair process and minimizes diver bottom time requirements.

6.1 Steel Beam Foundation

Concept: This concept utilizes steel wide-flange beams to form an expedient foundation for pile repair.

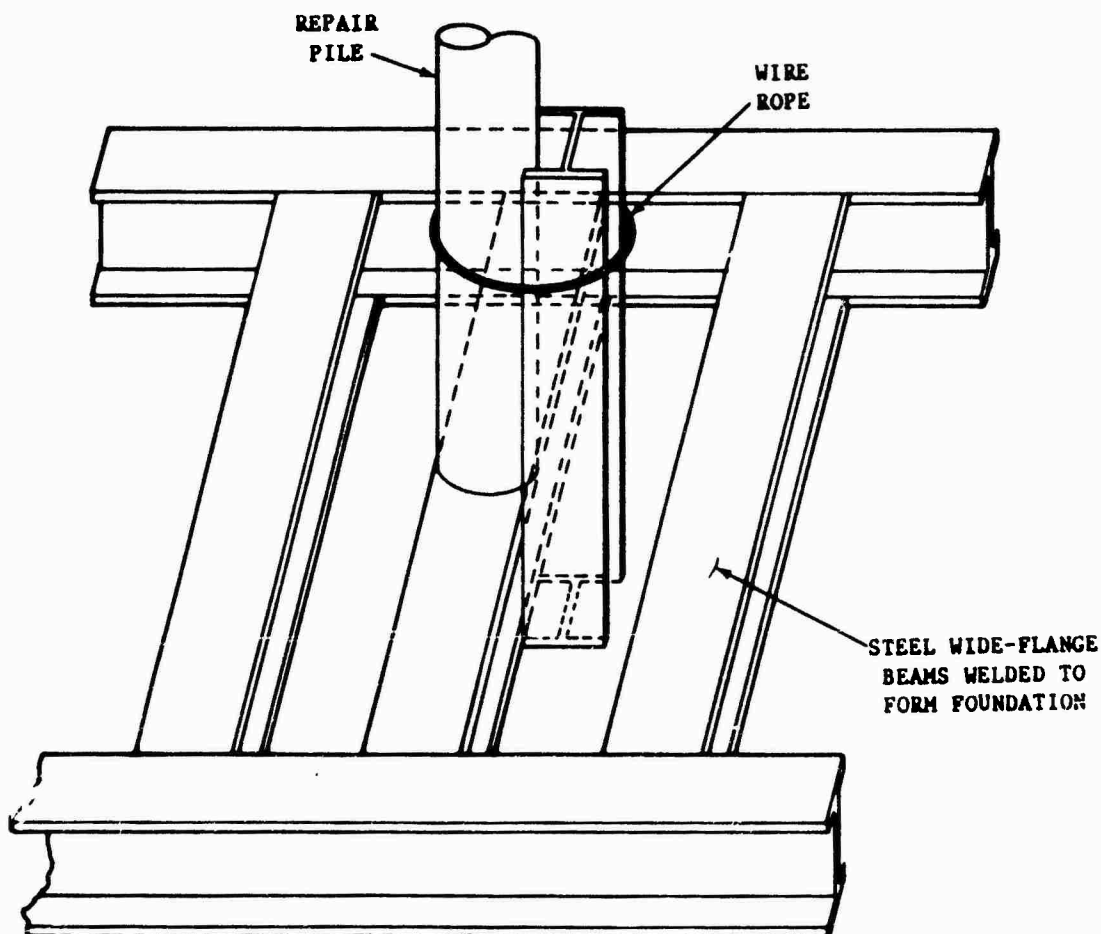

"H" BEAM FOUNDATION

Description: If pile placement is required where no pile previously existed, or if, due to extreme damage, the driven portion of a pile is unable to be used as a foundation, expedient foundations can be fabricated. This repair utilizes steel wide-flange beams to distribute the pile loads to the ocean floor. The beams are welded together and the repair column is placed on top of this foundation. A worst case soil bearing value of 2,000 lb/sq ft is assumed. This value and the pile loading determines the total area of the steel beams required to be in contact with the ocean floor. A level area, cleared of debris, is necessary for placement of this foundation. Because of this requirement and the likely settling of the foundation, this method should only be used if the base of the existing pile cannot be used as a foundation.

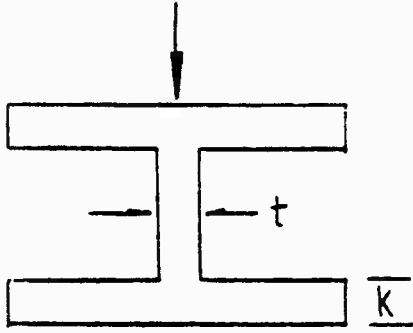

$$\text{MAX LOAD} = 24,000 \text{ PSI} (a + 2k)(t)$$

t = web thickness

a = length of concentrated load

k = thickness of flange

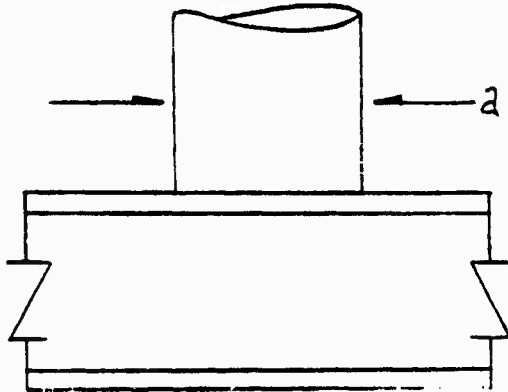

SAMPLE CALCULATION: BEAM SIZE - W6 x 16
 LENGTH OF CONCENTRATED LOAD = 12 in. = a
 t = 0.260 in.
 k = 0.404 in.

$$\text{MAX LOAD} = 24,000 \text{ PSI} [12 \text{ in.} + (2)(0.404 \text{ in.})] (0.260 \text{ in.})$$

$$= 79,922 \text{ lb}$$

MAX LOAD is the amount of concentrated load the web will withstand before failing between the flanges because of large local compressive stresses.

FAILURE BY WEB CRIPPLING DUE TO CONCENTRATED LOAD

(Reference: Civil Engineering Handbook; URGHART; p 3-49)

Example: The pile to be repaired is a 12 in. diameter steel pipe.

- a. From Table 7-1, the maximum allowable load for this pile is found to be 36 tons or 72,000 lb.
- b. The minimum foundation area needed to provide a footing for the pile load is found as follows:

$$\text{Area} = \text{load}/(\text{soil bearing value})$$
$$\text{Area} = 72,000 \text{ lb}/2,000 \text{ lb/sq ft} = 36 \text{ sq ft}$$

- c. A beam size is selected, and is checked for web crippling failure. Since the bearing area is dependant on the width of the flange, the widest flange available will provide the greatest contact area with the soil for a given length.

Beam chosen; W 12 x 53,
length of concentrated load = 12 in.
 $t = 0.345 \text{ in.}$
 $k = 0.576 \text{ in.}$
Max. load = $24,000 \text{ psi} [12 \text{ in.} + (2)(0.576 \text{ in.})] (0.345 \text{ in.})$
 = 108,899 lb
 $72,000 \text{ lb} < 108,899 \text{ lb}$

Therefore, web crippling will not occur, and this size can be used.

- d. The length and width of the beam determine the total bearing area.

$$\text{width} = 10.0 \text{ in.} = 0.833 \text{ ft}$$

The total length of beams needed is:

$$36 \text{ sq ft}/0.833 \text{ ft} = 43.2 \text{ lin ft}$$

A method of attaching the repair column to this foundation, as shown in the figure, should be provided. The best connection method will depend upon the materials available and the column material. Other suggested connection methods are given in Chapter 8.

6.2 Concrete Foundation

Concept: This concept utilizes 55 gal steel drums as concrete forms to fabricate an expedient foundation for pile repair.

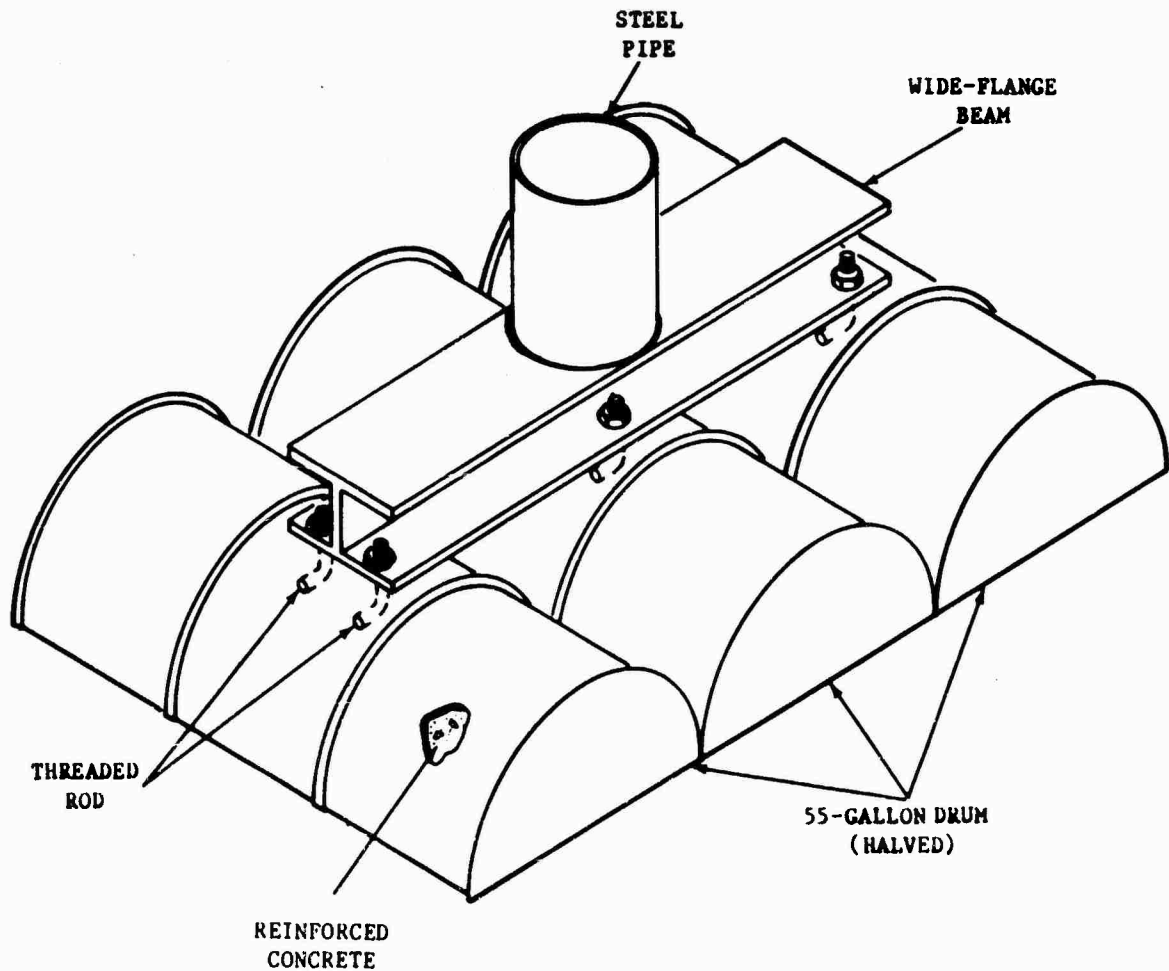

EXPEDIENT CONCRETE FOUNDATION

Description: As in the previous case, this technique should only be used if the base of the pile to be repaired cannot be used as a foundation, or the foundation is to be placed where no previous pile existed. In this repair, 55 gal steel drums are halved lengthwise and filled with reinforced concrete. Threaded rod is embedded in the concrete of each foundation member to provide a means of attaching these individual forms to one another. This is accomplished through the use of a steel wide-flange beam, which is attached to the threaded rods and evenly distributes the load to each of these individual foundation members.

Example: The repair is to be made on a 12 in.-diam. timber pile.

- a. From Table 7-1, the maximum allowable load for this pile is found to be 30 tons or 60,000 lb.
- b. The minimum foundation area needed to provide a footing for this pile load is found as follows:

Area = load/(soil bearing value)

Area = 60,000 lb/2,000 lb/sq ft = 30 sq ft

- c. A halved 55 gal oil drum has a rectangular area of 5.4 sq ft. The total number of concrete forms required is:

$30 \text{ sq ft} / 5.4 \text{ sq ft} = 5.56$

Therefore, six halved drums are to be used in this example (see Figure 6-1).

- d. Reinforcing bars or wire mesh must be placed within the concrete forms to provide additional strength.

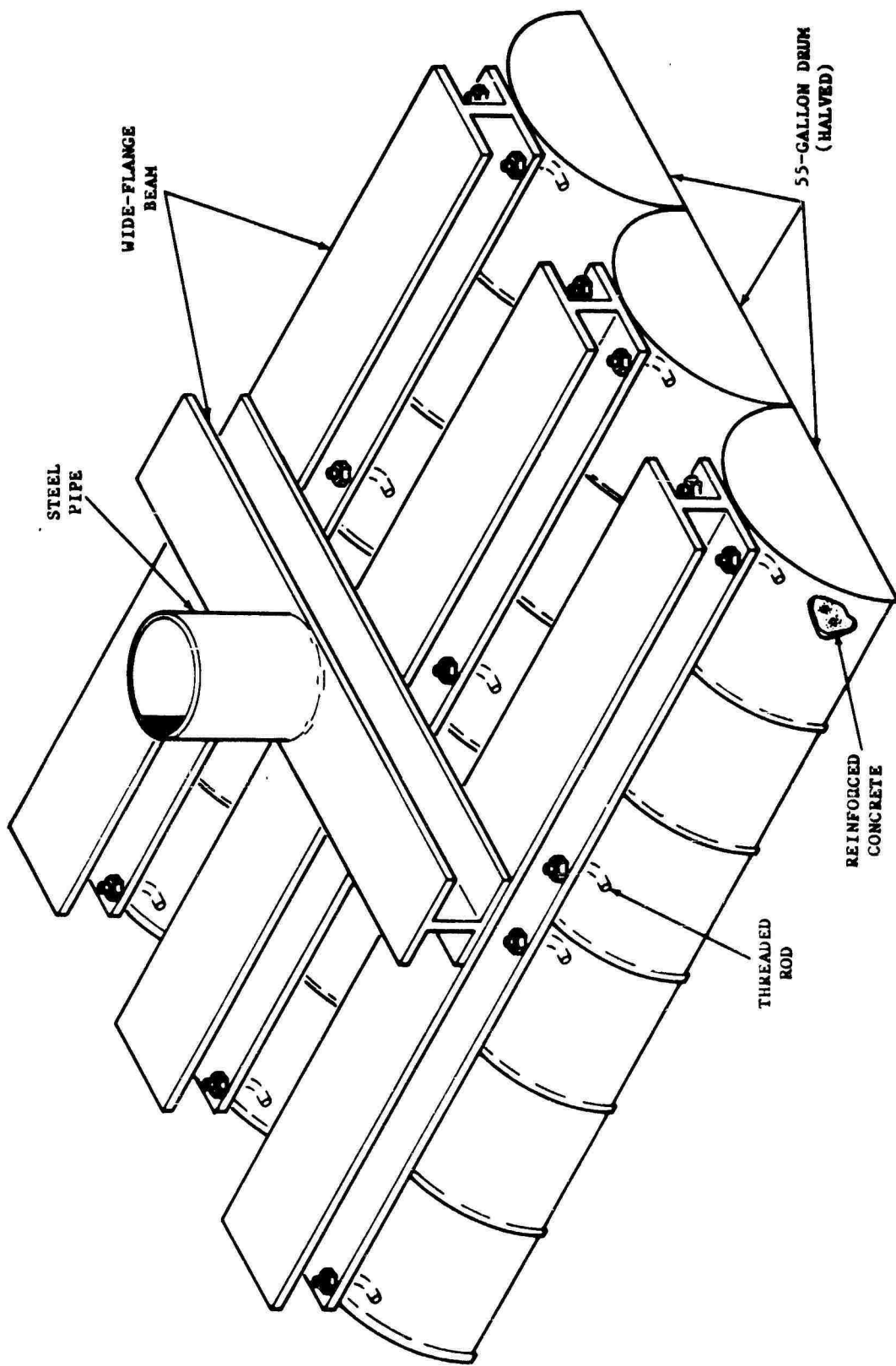
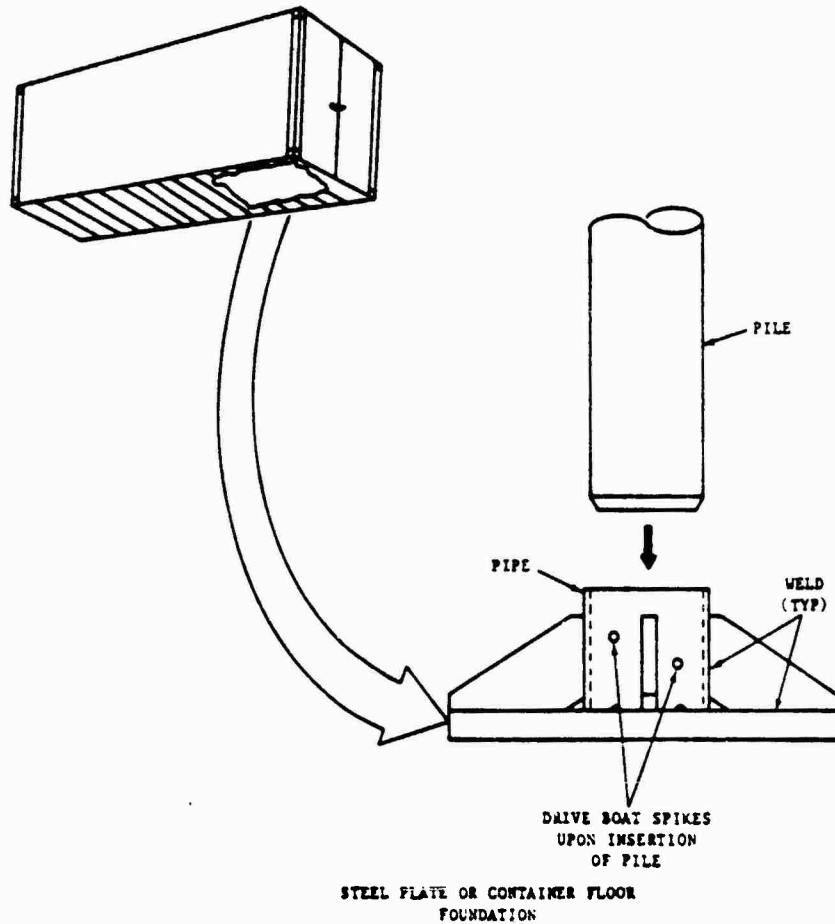

Figure 6-1. Expedient concrete foundation

6.3 Container Floor or Steel Plate Foundation

Concept: This concept utilizes a flat steel plate or the floor of an ISO container to provide a suitable foundation for a pile repair.



Description: An expedient pile foundation can be fabricated using steel plate or a portion of an ISO container floor. This foundation will provide a means of transferring the pile loads to the ocean floor. A steel pipe is attached to the center of this foundation, and gussets to resist bending are provided from this pipe to the outer edges of the plate. This repair requires a large level area at the point of application, and should be used if the base of the pile to be repaired cannot be used, or is unavailable.

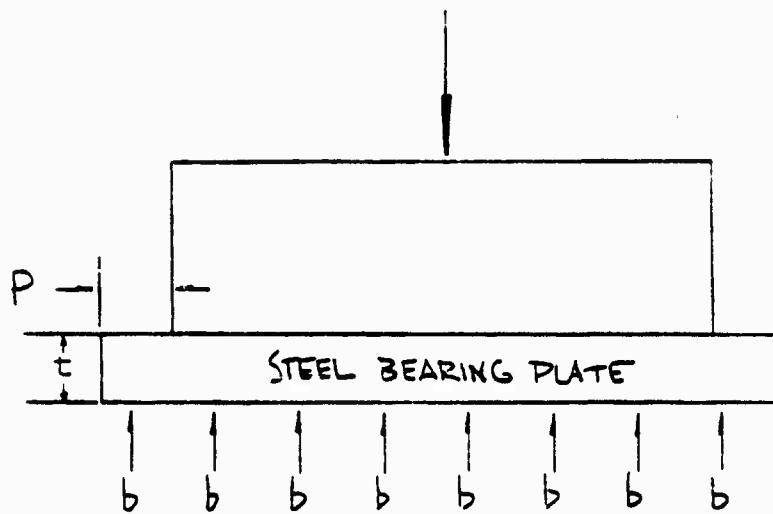

$$t = P \sqrt{3b/f}$$

f = fiber stress of material (PLATE) STEEL = 20,000 PSI

b = bearing value of base (UNIFORM LOAD)

P = distance from edge of pile to edge of plate

BEARING PLATE EQUATION

(Reference: Civil Engineering Handbook; Vignashart; p 6-47)

Example: A 10 in. octagonal concrete pile is to be repaired.

- a. From Table 7-1, the maximum allowable load for this pile is found to be 30 tons or 60,000 lb.
- b. The minimum foundation area needed to provide a footing for this pile load is found as follows:

$$\begin{aligned} \text{Area} &= \text{load}/(\text{soil bearing value}) \\ \text{Area} &= 60,000 \text{ lb}/2,000 \text{ lb/sq ft} = 30 \text{ sq ft} \end{aligned}$$

A 5 ft by 6 ft section of container floor could be used here. If steel plate were used, the bearing plate equation would be used to find the required plate thickness.

- c. To provide a means of connecting the repair column to this base, a steel pipe is attached to the center of the foundation, and gussets are welded to this pipe. The gussets run from the pipe to the outer edges of the foundation.

6.4 Rubble Foundation

Concept: This concept utilizes rubble and high early strength concrete to provide a foundation for a pier pile.

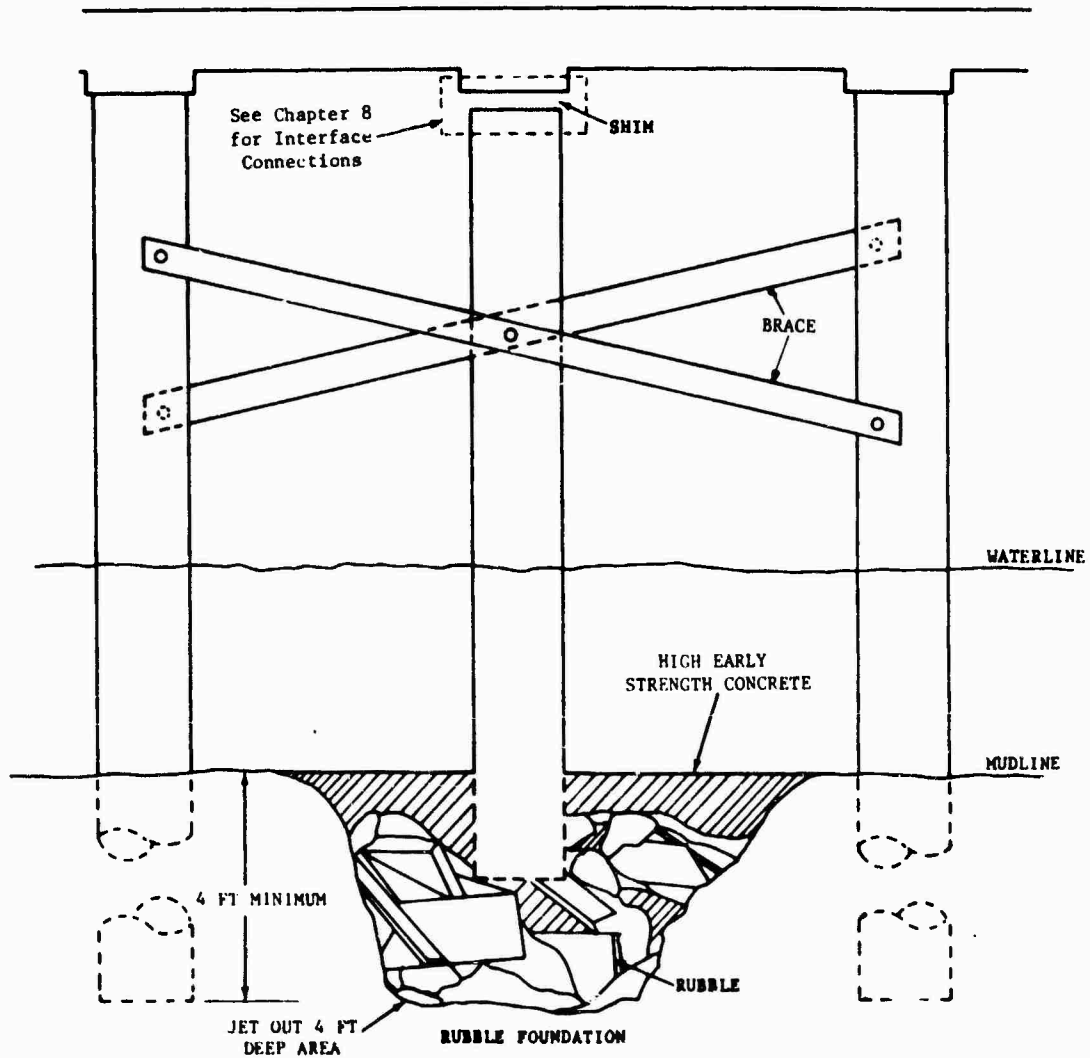

Description: An expedient pile foundation can be formed using steel scraps, concrete debris, and large rocks. The sea floor is excavated at the foundation site. The rubble is placed in this cavity, partially filling it. The repair column is placed on top of this rubble and braced in position. The hole is then filled with additional rubble, and high early strength concrete is pumped into the repair to consolidate the foundation. This expedient foundation will distribute the load from the pile to the ocean floor.

Example: A 14 in. square concrete pile is to be repaired.

- a. From Table 7-1, the maximum allowable load for this pile is found to be 42 tons or 84,000 lb.
- b. The minimum foundation area needed to provide a footing for the pile load is found as follows:

Area = load/(soil bearing value)

$$\text{Area} = 84,000 \text{ lb} / 2,000 \text{ lb/sq ft} = 42 \text{ sq ft}$$

This would require a circular excavated area of diameter D:

$$D = 2 (42/3.14)^{1/2} = 7.3 \text{ ft}$$

- c. This excavated area should be at least 4 ft deep.

7.0 Repair Concepts for Support Structures

The repair concepts in this section are based on the ability to repair the support structure to the equivalent strength of the undamaged piling. Figure 7-1 identifies the structural elements of a pier or wharf with a damaged pile to be repaired. Figure 7-2 presents several cross-sectional pile shapes and corresponding area formulas which are used for calculations. Using Table 7-1, the maximum allowable load per pile is assumed to be the actual loading for each size and type of pile listed. By equating like loads, equivalent pile sizes or diameters for steel, wood, and concrete piles were determined. Figures 7-3 and 7-4 were constructed using this information. All of the pile replacement concepts use this method of equivalency to determine the minimum size column required. By using this method, deck load capacities do not have to be known or calculated to repair the support structure.

Table 7-1. Maximum Allowable Loads Per Pile

Size or diameter* (inches)	Timber (tons)	Concrete (tons)	Steel friction (tons)
8-----	16	-----	20
10----	24	30	30
12----	30	36	36
14----	36	42	42
16----	42	48	-----

* On timber pile diameter is measured at a point one-third the length of the pile from the butt.

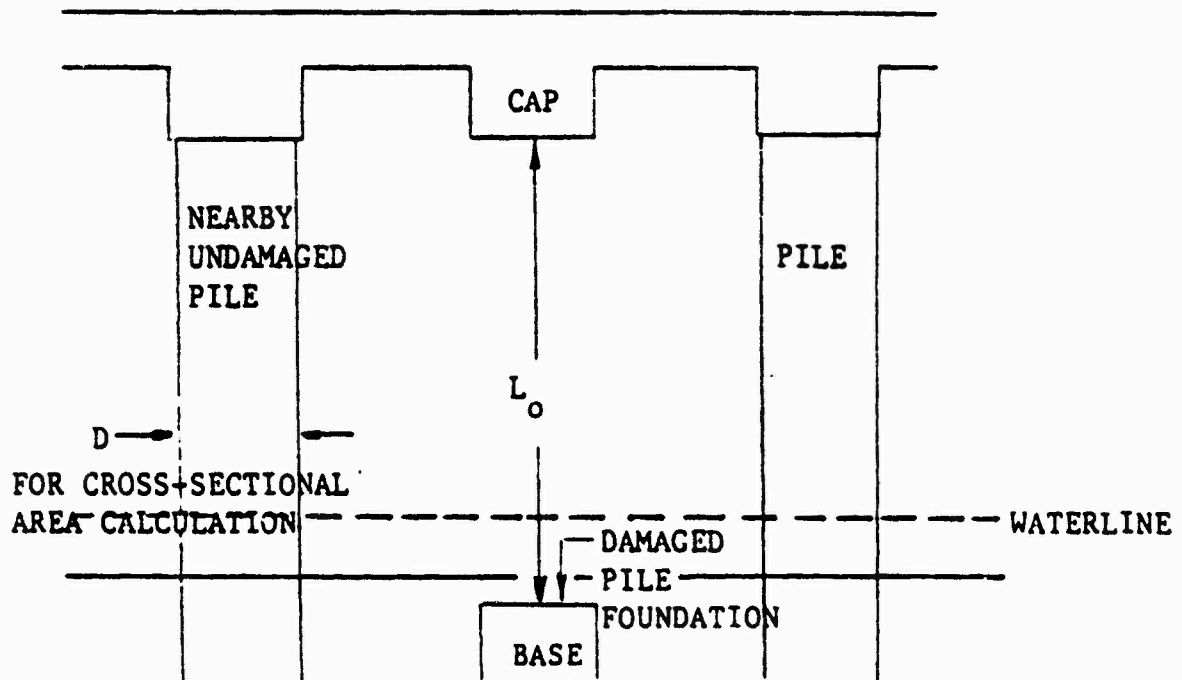
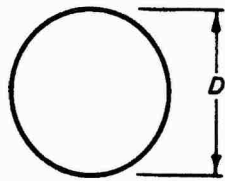
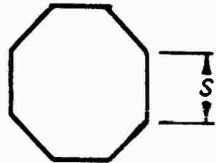

Figure 7-1. Pile repair nomenclature



$$\text{AREA} = \frac{3.14D^2}{4}$$



$$\text{AREA} = 2.598 S^2$$



$$\text{AREA} = D^2$$

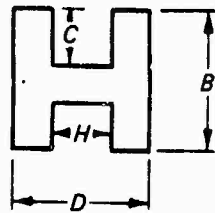

$$\text{AREA} = BD - 2HC$$

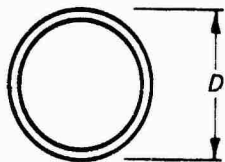

$$\text{AREA} = \frac{D - 4.35}{0.3}$$

Figure 7-2. Cross-sectional area formulas for adjacent pile

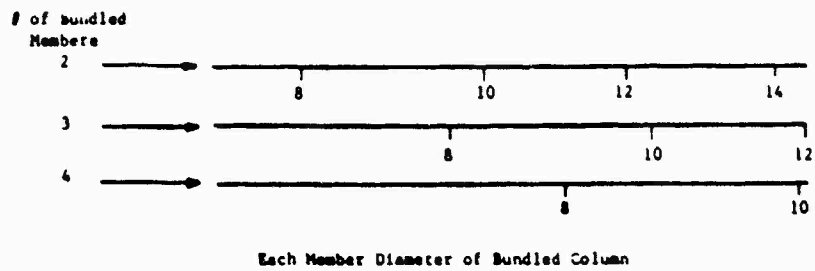
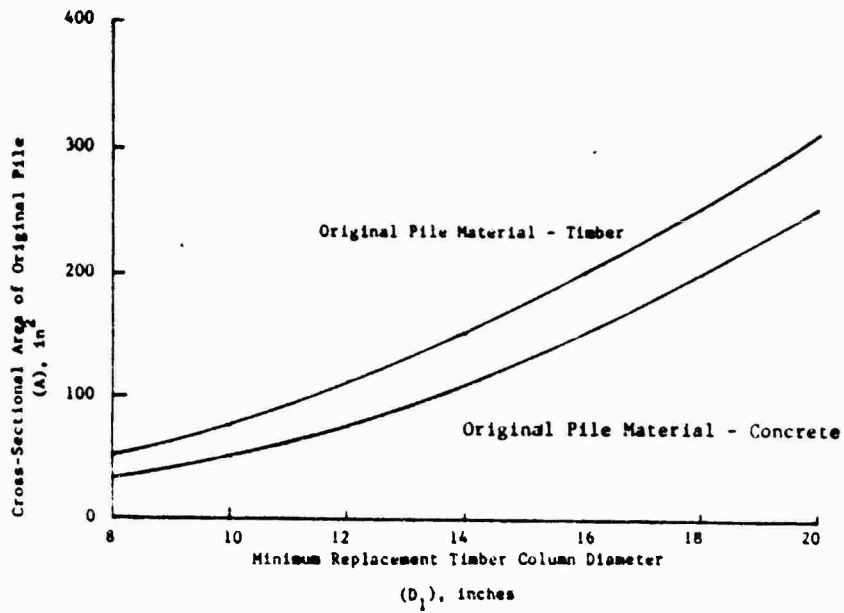
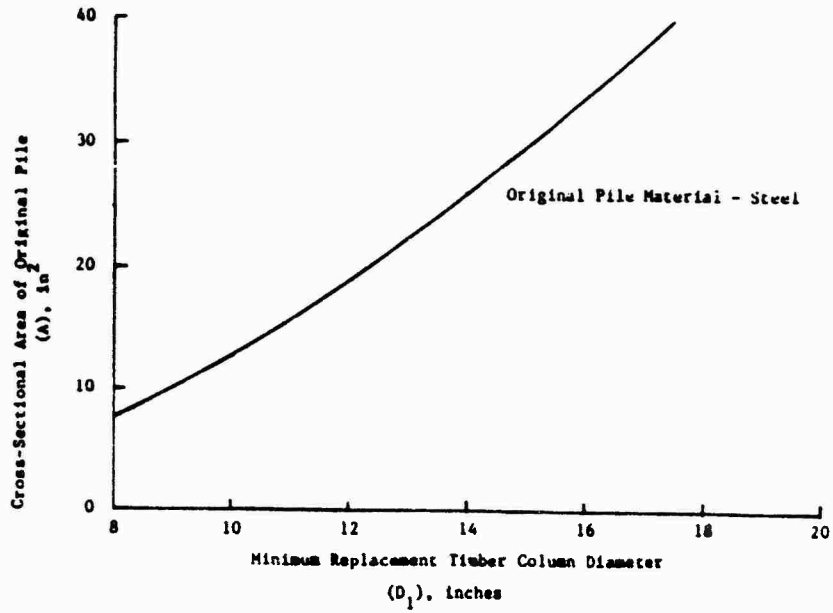

Figure 7-3. Replacement timber diameter determination

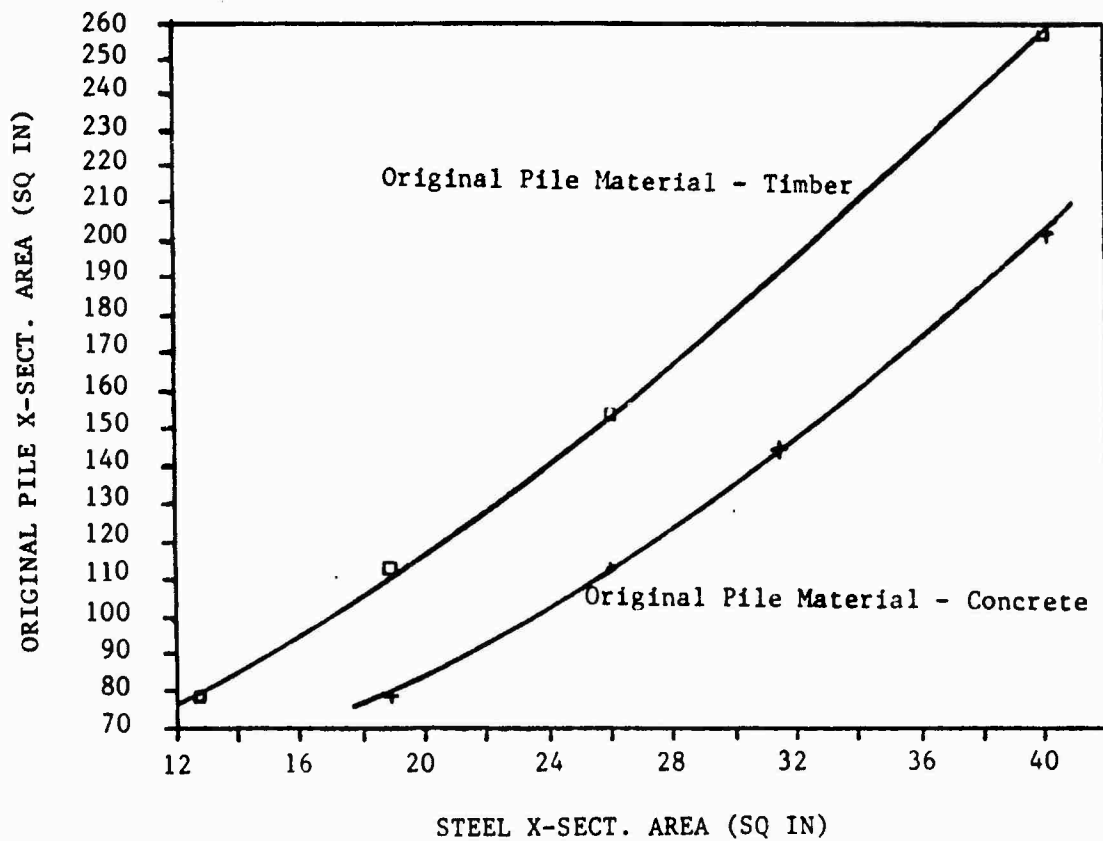
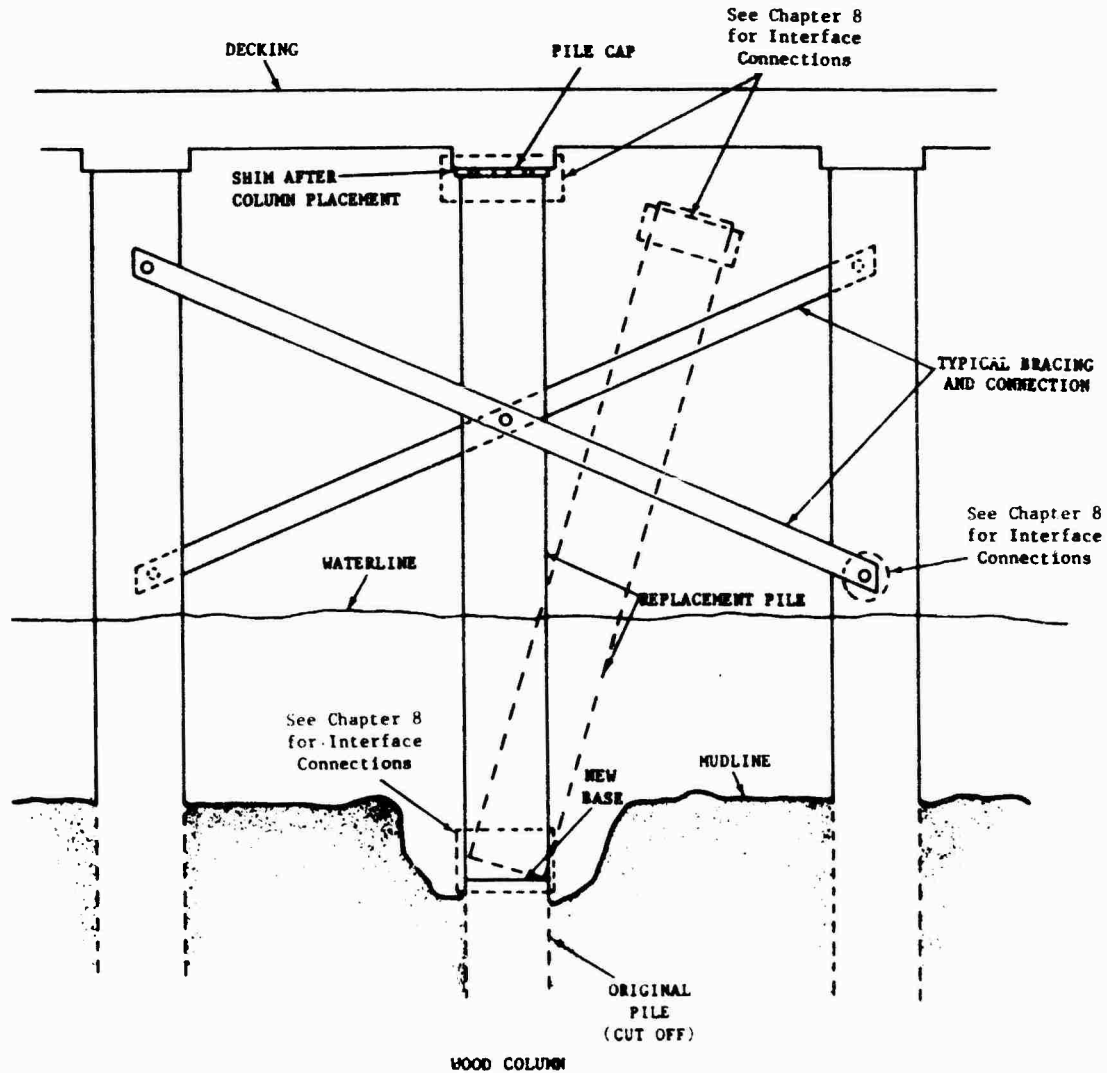

Figure 7-4. Equivalent steel cross-sectional area

7.1 Wood Columns

Concept: This concept uses a single wood column to replace an existing wood, concrete, or steel pile. The replacement column is to be placed on either the existing base or on one of the foundations conceptualized in Chapter 6.



Description: This repair uses, as a foundation, the undamaged portion of the existing disabled pile that is embedded in the ocean floor. In this way, the frictional resistance developed from the driving of the original pile can still be used to transfer the vertical loading of the column to the ocean floor. A wood column is placed on top of this foundation and is used to bridge the distance to the pile cap. If, due to excessive marine borer or mechanical damage, it is not possible to use this portion of the pile as a foundation, an expedient foundation can be fabricated using the concepts of Chapter 6. The bracing pattern as shown is typical, and is used to resist lateral loads. These loads result from mooring, wind, current, and wave forces.

Example: The repair is to be made on a square concrete pile, with cross-sectional dimensions of 16 in. on each side. From Figure 7-2, an area of 256 sq in. is determined.

- a. From Figure 7-3, it is found that the equivalent replacement timber column must be at least 20 in. in diameter.
- b. Methods of connecting the repair column to the foundation and pile cap are given in Chapter 8. Since the column and foundation are of differing diameters, Connecting Methods 4, 6, and 7 can be used at the base, and Method 4 could be used at the pile cap connection.
- c. Typically, the brace members are attached to the piles using a single bolt. Chapter 8 gives common bracing techniques. Here, Method 1 would be used for the timber column, and Method 3 would be used to brace the remaining concrete piles.

7.1.1 Bundled Wood Columns

Comments: This concept uses a bundle of wood columns to replace an existing wood, concrete, or steel pile. The bundled column is to be placed on either the existing base or on foundations conceptualized in Chapter 6.

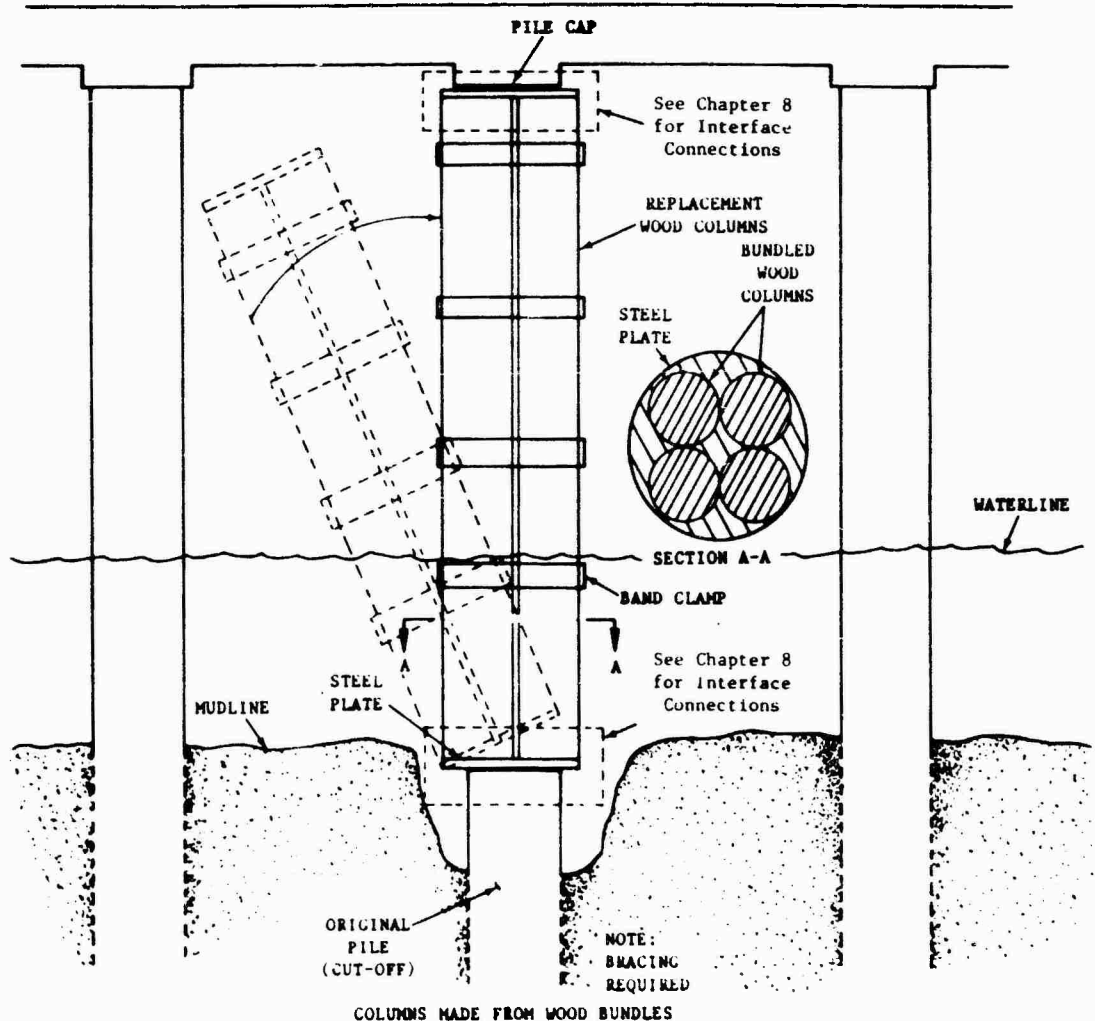

Description: As examined in the single wood column concept, this repair uses the undamaged portion of the existing disabled pile as a foundation. If the necessary column material required for a single column replacement is not available, several smaller diameter wood columns may be used. These columns would be bundled together in groups of two, three, or four members. Steel band strapping, spaced every foot of column length, is used to hold the separate members together. The bundled column would then bridge the gap between the foundation and the pile cap. Bracing, as previously discussed, is required. A steel bearing plate is also required to transfer the loads from the pile cap to the column, and from the column to the foundation.

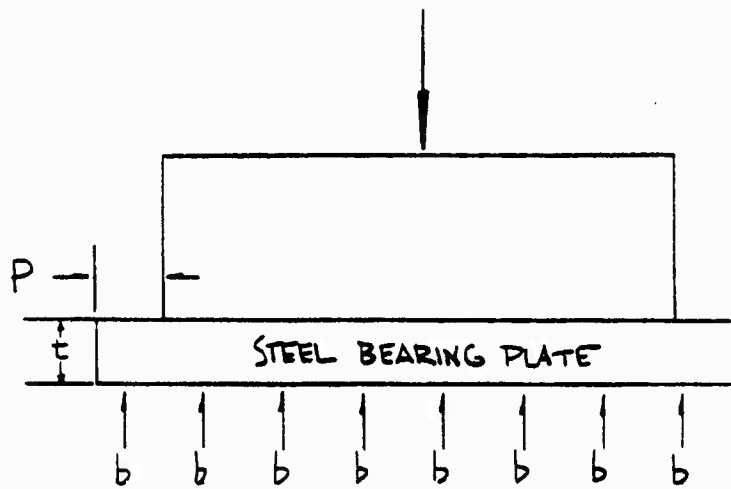

$$t = P \sqrt{3b/f}$$

f = fiber stress of material (PLATE) STEEL = 20,000 PSI

b = bearing value of base (UNIFORM LOAD)

P = distance from edge of pile to edge of plate

BEARING PLATE EQUATION

(Reference: Civil Engineering Handbook; Urquhart; p 6-47)

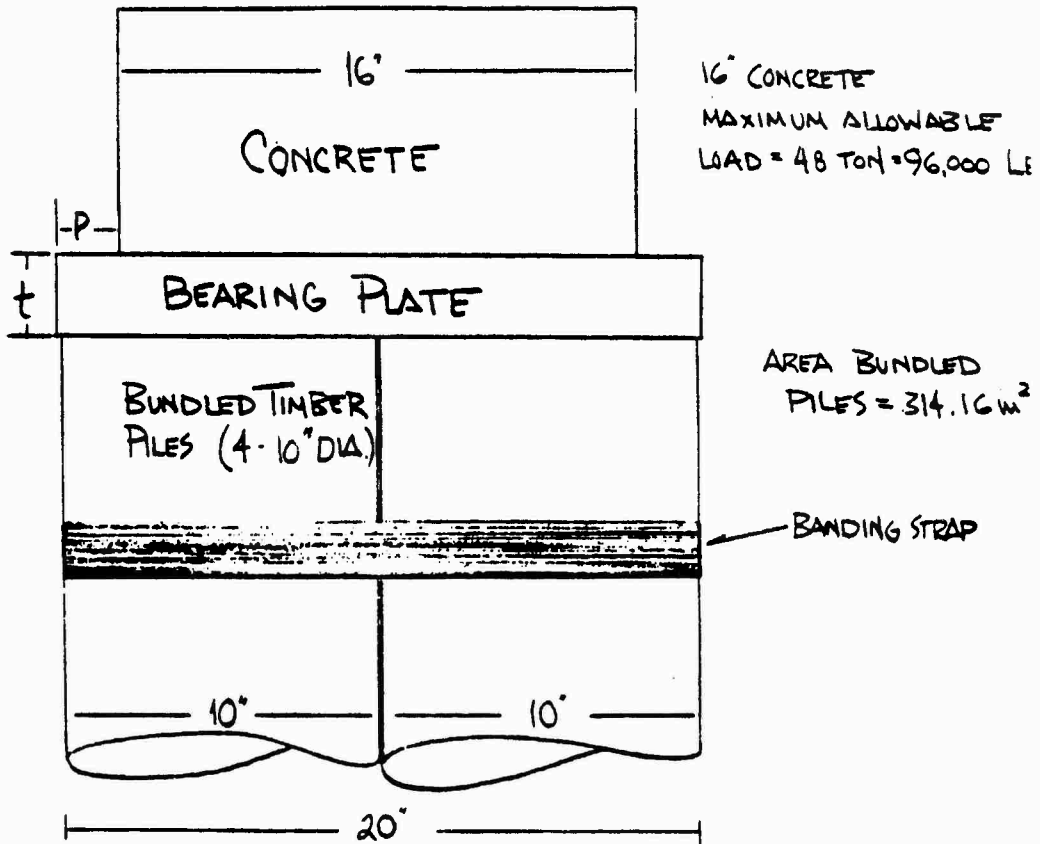

$$t = P \sqrt{3b/f} \quad \text{Where: } f = 20,000 \text{ PSI}$$

$$b = \frac{96,000 \text{ LBS}}{314.16 \text{ m}^2} = 305.58 \text{ PSI}$$

$$P = 2 \text{ in.}$$

$$t = 2 \sqrt{\frac{(3)(305.58)}{20,000}} = 0.428 \text{ in.}$$

USE $\frac{1}{2}$ INCH STEEL PLATE

Example: The repair is to be made on a square concrete pile, with cross-sectional dimensions of 16 in. on each side. This gives an area of 256 sq in.

- a. From Figure 7-3, it is found that an equivalent replacement column can be made up of a bundle of four, 10 in. diameter timber columns.
- b. A steel bearing plate must be placed between the differing diameters of the bundled column and base or cap. Calculations for determining the bearing plate thickness required are presented with this concept.
- c. Methods of connecting the repair column to the foundation and pile cap are given in Chapter 8. Because the column and foundation are of differing diameters, Connecting Method 6 or 7 is recommended at the base, and Method 4 is recommended at the cap.
- d. Common bracing techniques are examined in Chapter 8. In this example, a variation of Method 1, where the bracing bolt runs through two of the bundled column members, would be used to connect the brace to the bundled column, and Method 3 would be used to brace the remaining concrete piles.

7.2 Steel Columns

Concept: This concept uses a steel column to replace an existing wood, concrete, or steel pipe. The replacement column is to be placed on either the existing base or on a foundation conceptualized in Chapter 6.

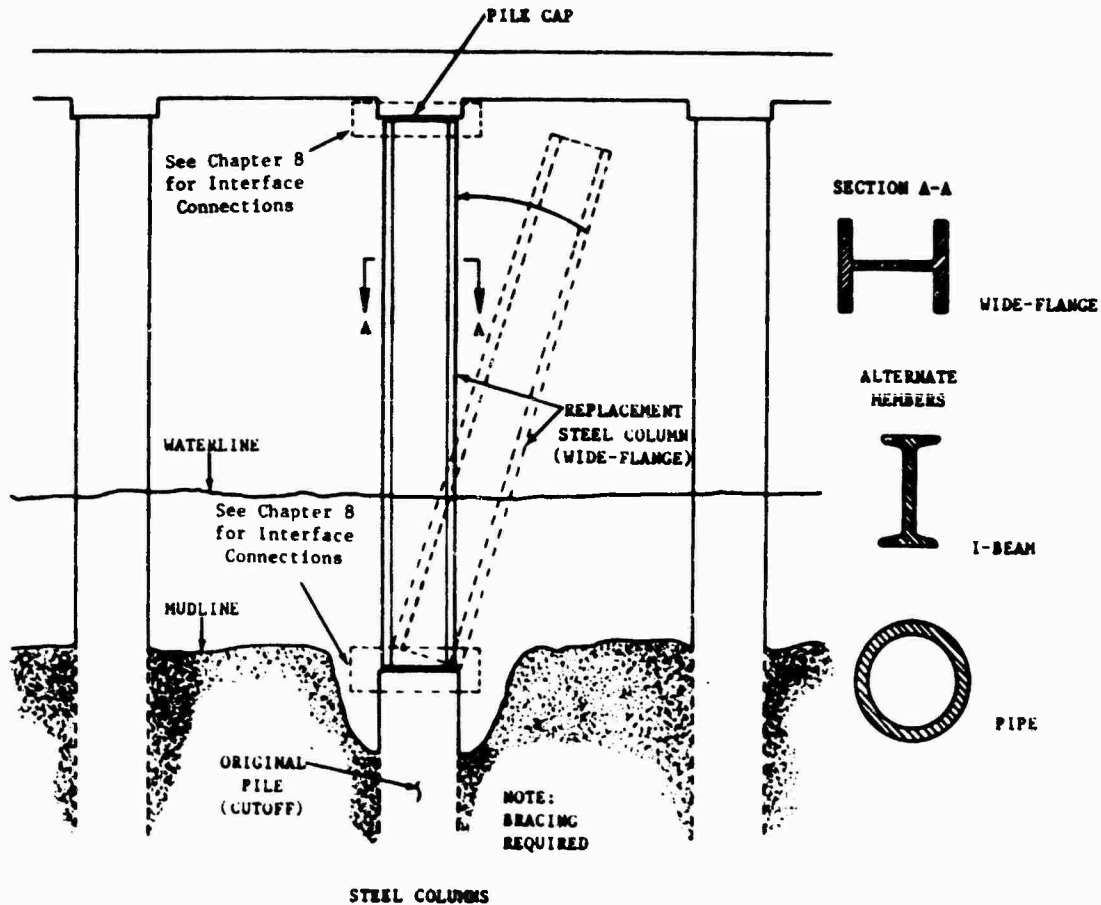

Description: This repair concept also utilizes the bearing capacity of the base of the damaged pile. A steel column of sufficient strength to transfer the deck loading to this foundation is used. The strength of the steel column member is dependant upon its cross-sectional area and shape. The shape determines the member's ability to resist buckling for a given column length. Bracing, as previously described, is required to resist lateral forces.

Example: Excessive damage was sustained in a 14 in. diameter timber pile. From Figure 7-2, the cross-sectional area of this pile is found to be 154 sq in. The replacement column must be 30 ft long, (L).

- a. From Figure 7-4, it is found that a steel cross-sectional area equivalent to this timber area is 26 sq in.
- b. To assure buckling of this column does not occur, the ratio of the column length to the least radius of gyration (r) of the steel shape (slenderness ratio) is to be kept below 120, ($L/r < 120$).
- c. The steel replacement column must satisfy the two requirements above. In this example, a steel wide-flange member is to be used. A W 14 by 103 steel section has a cross-sectional area of 30.3 sq in. and a least radius of gyration of 3.72 in. These values of (r) and (A) are given for several steel member shapes and sizes in Tables 7-2 through 7-5. Therefore;
 $L/r = 360 \text{ in.}/3.72 \text{ in.} = 96.8 < 120.$

This member does satisfy both requirements and can be used.

- d. The Connecting Methods of Chapter 8 suggest ways to attach the column to the foundation and pile cap. Method 5 applies here.
- e. The column is to be braced according to the suggestions of Chapter 8.

Table 7-2. Steel Wide-Flange Section Properties

Steel Wide-Flange Sections				
Designation Depth, in. X Weight, lb/ft	Actual Depth, in.	Width, in.	Cross- Sectional Area, sq in.	Least Radius of Gyration, in.
W 8X28	8.06	6.540	8.23	2.08
X35	8.12	8.027	10.30	2.03
X48	8.50	8.117	14.10	1.62
W 10X33	9.75	7.964	9.71	1.94
X49	10.00	10.000	14.40	2.54
X66	10.38	10.117	19.40	2.58
W 12X36	12.24	6.565	10.60	1.55
X53	12.06	10.000	15.60	2.48
X85	12.50	12.105	25.00	3.07
W 14X34	14.00	6.750	10.00	1.52
X53	13.94	8.062	15.60	1.92
X74	14.19	10.072	21.80	2.48
X103	14.25	14.575	30.30	3.72
X136	14.75	14.740	40.00	3.77
W 16X36	15.85	6.992	10.60	1.52
X50	16.25	7.073	14.70	1.59
X71	16.16	8.543	20.90	1.99
W 18X40	17.90	6.018	11.80	1.27
X60	18.25	7.558	17.70	1.68
X85	18.32	8.838	25.00	2.05
W 24X55	23.55	7.000	16.20	1.34
X84	24.09	9.015	24.70	1.95
X110	24.16	12.042	32.50	2.77

Table 7-3. Steel "S" Section Properties

Steel "S" Sections (I-Beam)				
Designation Depth, in. X Weight, lb/ft	Actual Depth, in.	Width, in.	Cross- Sectional Area, sq in.	Least Radius of Gyration, in.
S 10X35.0	10.0	4.944	10.3	0.901
S 12X35.0	12.0	5.078	10.3	0.980
X50.0	12.0	5.477	14.7	1.030
S 15X42.9	15.0	5.501	12.6	1.070
X50.0	15.0	5.640	14.7	1.030
S 18X54.7	18.0	6.001	16.1	1.140
X70.0	18.0	6.251	20.6	1.080
S 20X65.4	20.0	6.250	19.2	1.190
X85.0	20.0	6.391	25.0	1.360
S 24X79.9	24.0	7.001	23.5	1.340
X90.0	24.0	7.124	26.5	1.300
X100.0	24.0	7.247	29.4	1.270

Table 7-4. Schedule 40 Pipe Properties

Schedule 40 Pipe				
<u>Nominal Size, in.</u>	<u>Actual O.D., in.</u>	<u>Wall Thickness in.</u>	<u>Cross- Sectional Area, sq in.</u>	<u>Radius of Gyration, in.</u>
6	6.625	0.280	5.58	2.245
8	8.625	0.322	8.40	2.938
10	10.750	0.365	11.91	3.674
12	12.750	0.406	15.74	4.364
16	16.000	0.500	24.35	5.484
18	18.000	0.562	30.79	6.168
20	20.000	0.594	36.21	6.864
24	24.000	0.688	50.39	8.246

Table 7-5. Schedule 80 Pipe Properties

Schedule 80 Pipe				
<u>Nominal Size, in.</u>	<u>Actual O.D., in.</u>	<u>Wall Thickness in.</u>	<u>Cross- Sectional Area, sq in.</u>	<u>Radius of Gyration, in.</u>
6	6.625	0.432	8.41	2.195
8	8.625	0.500	12.76	2.878
10	10.750	0.594	18.95	3.597
12	12.750	0.688	26.07	4.271
14	14.000	0.750	31.22	4.692
16	16.000	0.844	40.19	5.366
18	18.000	0.938	50.28	6.041
20	20.000	1.031	61.44	6.716
22	22.000	1.125	73.78	7.391

7.2.1 Welded Steel Rail Columns

Concept: This concept utilizes steel rail to form a column and to replace a damaged wood, concrete, or steel pile. The replacement column is to be placed on either the existing base or on a foundation conceptualized in Chapter 6.

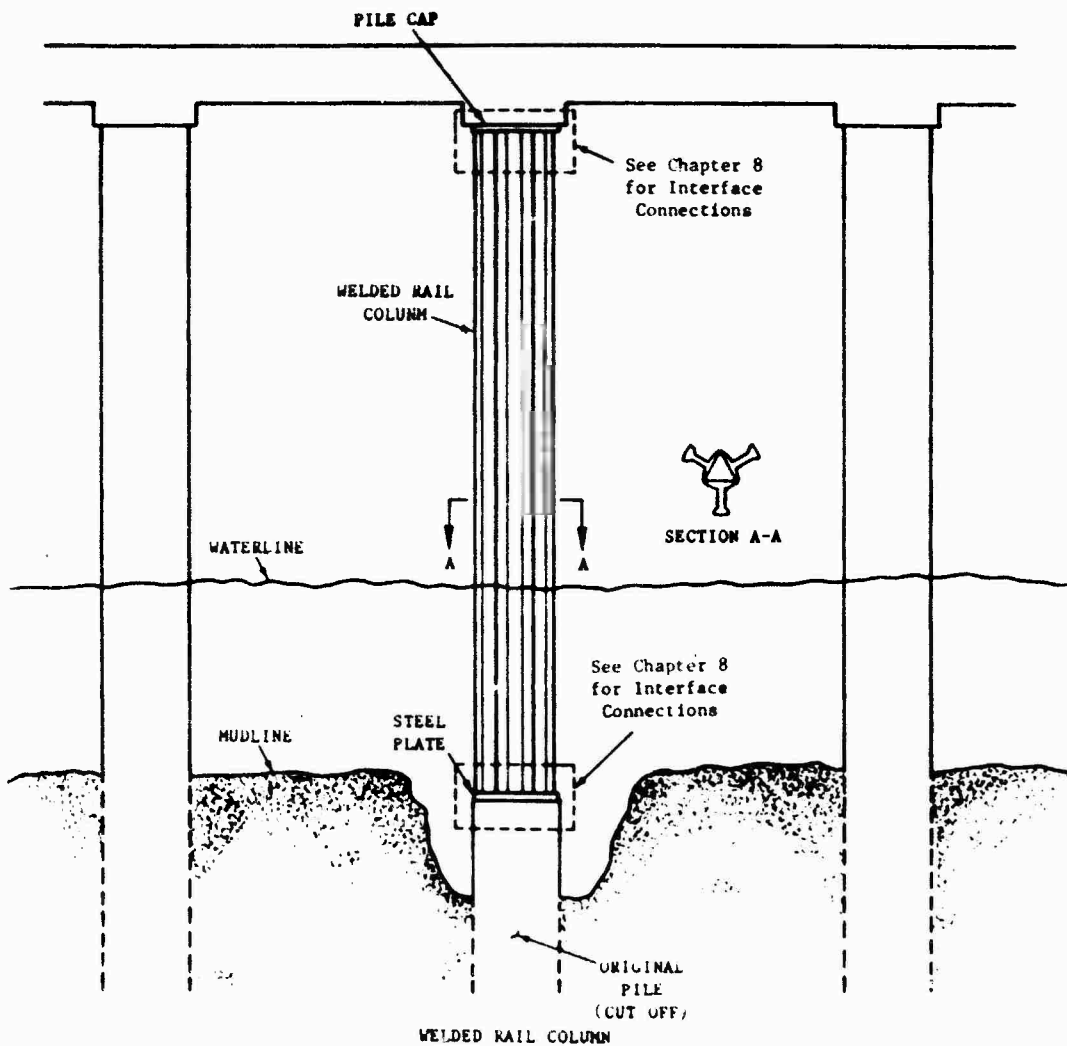

Description: An expedient steel column can be fabricated using steel rail. Three sections of rail can be welded together to form a column. This column has improved strength characteristics, resulting from the delta configuration. The column runs between the pile cap and the undamaged portion of the original pile. Using the common 115 lb/yd rail, this repair is limited to repairs requiring column lengths of 37.7 ft or less. Bracing is required to resist lateral forces.

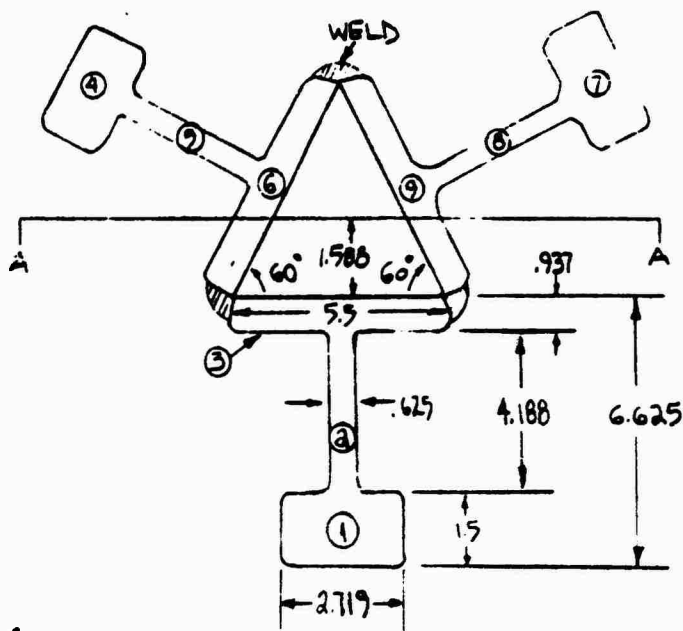

$$\theta = 60^\circ$$

$$I_1 = I_1 + Ad^2 = \frac{bh^3}{12} + bhd^2 = \frac{2.719(1.5)^3}{12} + 2.719(1.5)(.75 + 4.188 + .937 + \frac{5.5 \sin 60^\circ}{3})^2 = 227.92$$

$$I_2 = I_2 + Ad^2 = \frac{.625(4.188)^3}{12} + .625(4.188)(1.588 + .937 + 2.094)^2 = 59.67$$

$$I_3 = I_3 + Ad^2 = \frac{5.5(.937)^3}{12} + .937(5.5)(1.588 + \frac{.937}{2})^2 = 22.17$$

$$I_4 = \frac{bh}{12} (h^2 \cos^2 \theta + b^2 \sin^2 \theta) = \frac{(2.719)1.5}{12} [(1.5)^2 \cos^2 60^\circ + (2.719)^2 \sin^2 60^\circ] = 2.08$$

$$I_5 = \frac{bh}{12} (h^2 \cos^2 \theta + b^2 \sin^2 \theta) = \frac{.625(4.188)}{12} [(4.1875)^2 \cos^2 60^\circ + (.625)^2 \sin^2 60^\circ] = 1.02$$

$$I_6 = \frac{bh}{12} (h^2 \cos^2 \theta + b^2 \sin^2 \theta) = \frac{5.5(.9375)}{12} [(9375)^2 \cos^2 60^\circ + (5.5)^2 \sin^2 60^\circ] = 9.84$$

$$I_7 = I_4$$

$$I_8 = I_5$$

$$I_9 = I_6$$

$$I_{10} = -\frac{Wh^3}{3C} = -\frac{5.5(5.5 \sin 60)^3}{3C} = -16.51$$

$$\begin{aligned} \sum I &= 227.92 + 59.67 + 22.17 + 2.08 + 1.02 + 9.84 + 2.08 + 1.02 \\ &\quad + 9.84 - 16.51 = \underline{\underline{319.13 \text{ m}^4}} \end{aligned}$$

$$\begin{aligned} \sum A &= 4.078 + 4.078 + 4.078 + 2.617 + 2.617 + 2.617 + 5.156 + 5.156 \\ &\quad + 5.156 - 9.84 = \underline{\underline{22.4 \text{ m}^2}} \end{aligned}$$

$$\begin{aligned} r = \text{radius of gyration} &= \sqrt{\frac{\sum I}{\sum A}} \\ &= \sqrt{\frac{319.13 \text{ m}^4}{22.4 \text{ m}^2}} = \underline{\underline{3.77 \text{ m}}} \end{aligned}$$

L = unsupported length

$\frac{L}{r}$ = slenderness ratio

$$\frac{L}{r} < 120$$

$$L < 377 \text{ m. (120)} \times \frac{1 \text{ foot}}{12 \text{ m.}}$$

$$L < 37.7 \text{ feet}$$

Example: A 14 in. diameter steel pipe pile with a cross-sectional area of 31.2 sq in. is to be repaired. The damaged area requires a column 32 ft long.

- a. Since the damaged pile is steel, the minimum steel rail cross-sectional area required can be determined by equating this area to the original pile cross-sectional area. In this example, the column area must be at least 31.2 sq in. A section of 115 lb/yd rail has a cross-sectional area of 11.85 sq in., therefore the total area of three sections is 35.6 sq in.
- b. Calculations for determining the least radius of gyration for this welded column are presented with this concept. The least radius of gyration for this fabricated rail column is 3.77 in.
- c. The slenderness ratio (L/r) should be less than 120 in order to resist buckling of the column.

Therefore: $L/r = 384 \text{ in.}/3.77 \text{ in.} = 101.9 < 120.$

This repair column meets both the area and buckling resistance requirements and can therefore be used.

- d. Suggested Connecting Methods and Bracing techniques are given in Chapter 8.

7.3 Reinforced Concrete Pile Repairs

Concept: This concept utilizes reinforced concrete to repair a damaged section of a pile. It can be used to repair wood, concrete, or steel piles.

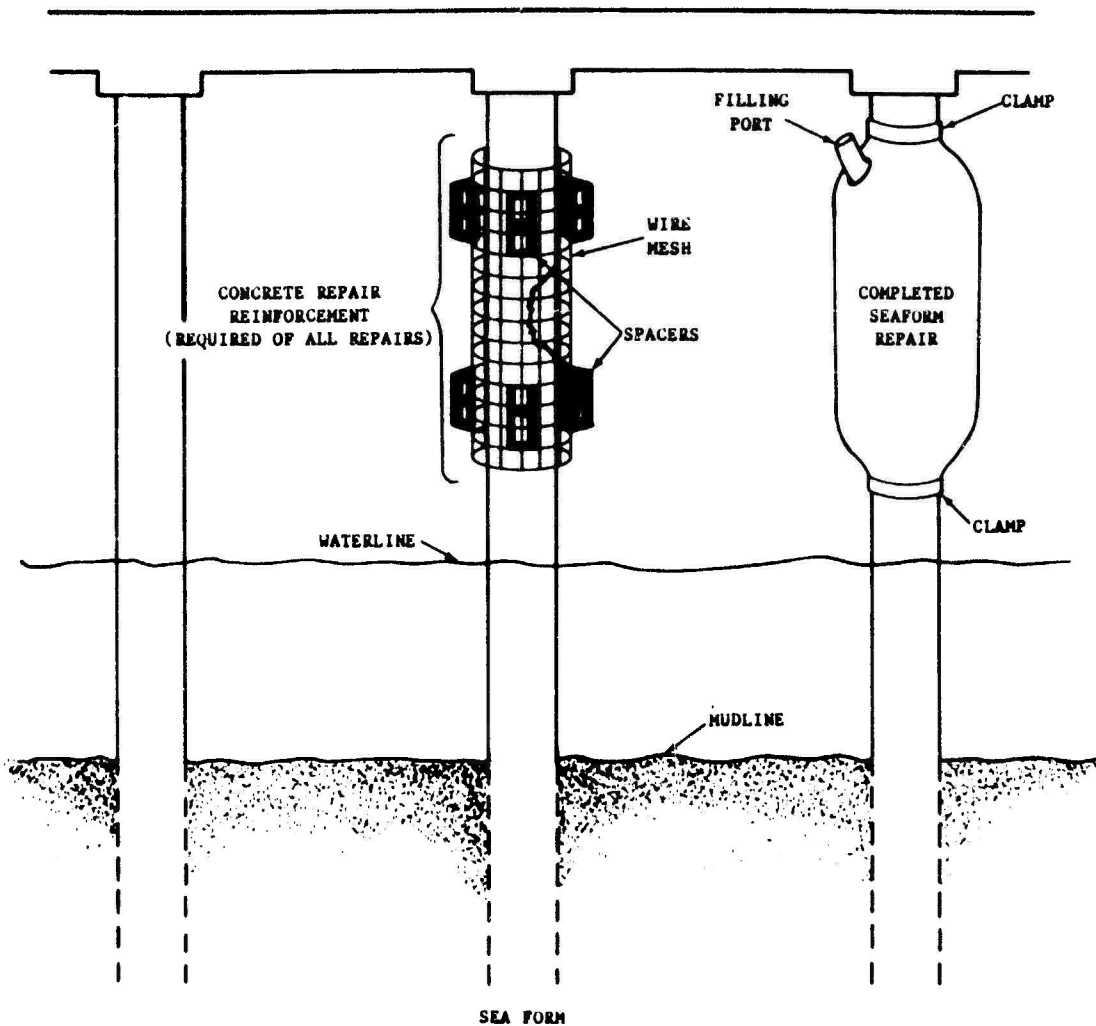

Description: This method is used to repair a pile that has been damaged, yet is still intact from the sea floor to the pile cap. This method can be used to repair split or broken timber piles, cracked or chipped concrete piles, or mechanically damaged steel piles. Steel reinforcement is placed around the repair area, and a form is used to contain the concrete. If "Sea Form" fabric forms are not available, expedient forms can be made from culvert pipe, oil drums, or corrugated roofing. The damaged area of the pile is then encased in concrete.

Example: A 10 in. diameter timber pile is to be repaired.

- a. The damaged area must be cleaned of loose debris.
- b. Reinforcing wire mesh is placed around the pile repair area, with spacers being used to keep the reinforcement centered in the concrete repair. A minimum concrete wall thickness of 6 in. is required.
- c. A form is placed around the repair area. If an expedient form (as shown in Figure 7-5) is used, a base is required.
- d. Concrete is tremied or poured into the form until sound concrete flows out of the top. It is important that the concrete forms a continuous wall around the repair area.

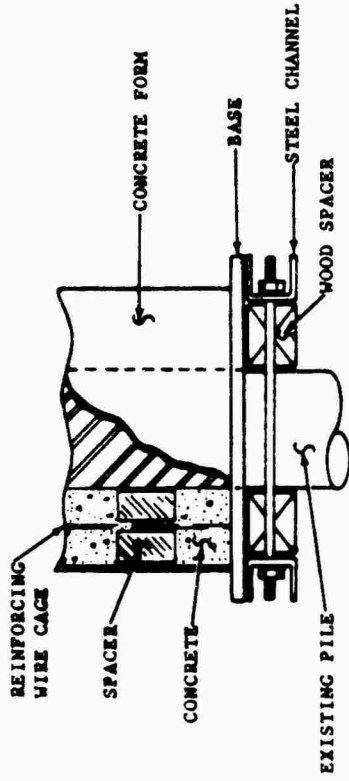
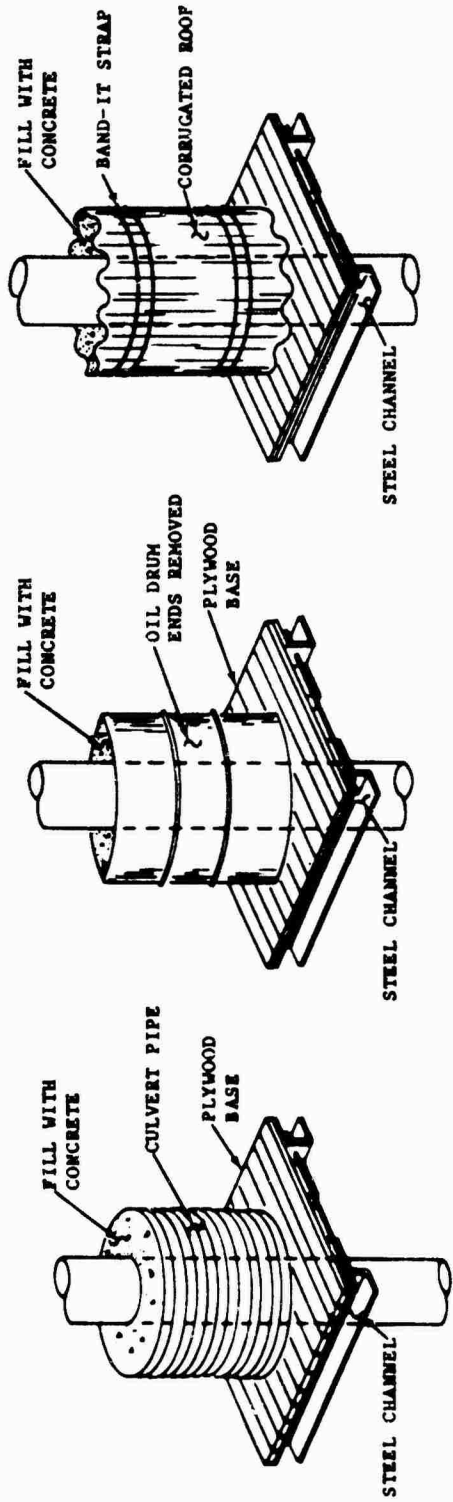

ALTERNATE FORMS

Figure 7-5. Alternate forms

7.4 Container Used as Pile Replacement

Concept: This concept utilizes stacked ISO containers to replace a pier pile.

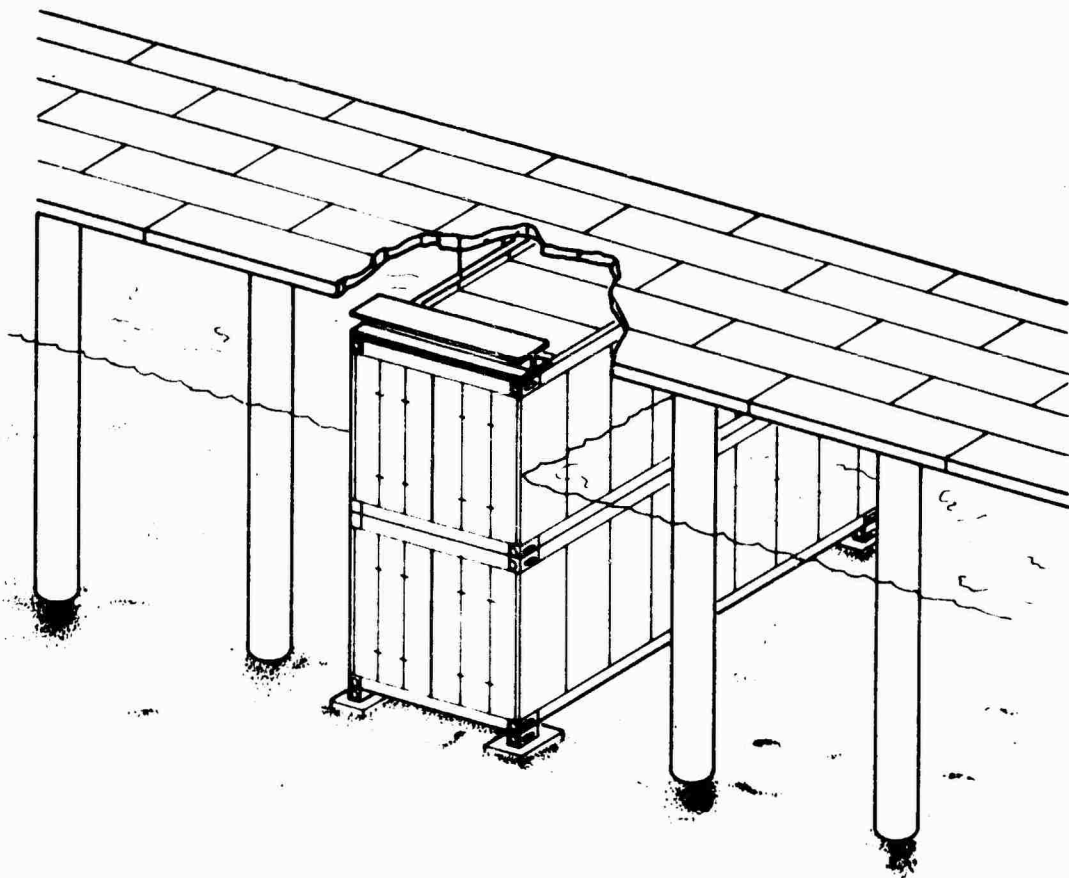

CONTAINER AS SUPPORT STRUCTURE

Description: This repair uses, as a column, the corners of an ISO container. If the repair requires a column of greater length, up to five containers can be stacked on top of one another. Only the corners of these containers have the ability to support a substantial load. A beam is used to span the distance from corner to corner. The calculations that follow give several beam loading cases. This method will support the maximum pile loads given in Table 7-1.

The corners must be placed on individual foundations to minimize the ocean floor area required to be cleared. These foundations must have a cumulative area equal to the minimum foundation area as required in Chapter 6. The containers must be level for proper load distribution. This is accomplished through the shimming of the foundation footings. Lightening holes should be provided in the sides, tops, and bottoms of the containers to lessen the water forces (current or wave) acting on these surfaces.

PILE REPLACEMENT USING CONTAINERS

- attach beam section to loose corner fittings that will match up w/ corner fittings on container
- spacer section may be placed between corner fitting & beam section to adjust height of top.

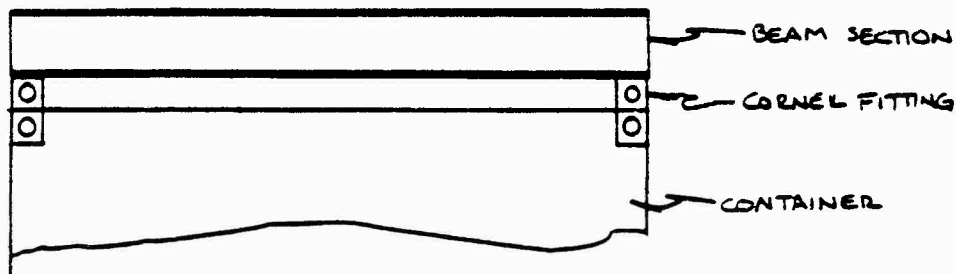

CASE 1 -

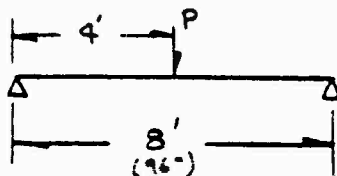

$$P = 30 \text{ k}$$

$$M = \frac{Pl}{4} = \frac{(30\text{k})(8\text{ft})}{4} = 60 \text{ ft}\cdot\text{k}$$

FROM FIGURE 7-6 $l = 8$, $M = 60 \text{ ft}\cdot\text{k}$

lightest section = W 16 x 26

acceptable sections = W 8 x 35

W 12 x 27

for W 16 x 26 section - $I = 300 \text{ in}^4$

$$\Delta = \frac{Pl^3}{48EI} = \frac{(30\text{k})(96\text{in})^3}{48(29 \times 10^3\text{ksi})(300\text{in}^4)} = 0.064 \text{ in}$$

CASE 2 -

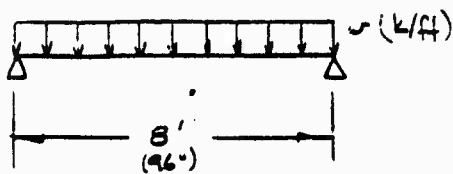

$$w = \frac{30k}{8ft} = 3.75 \text{ k/ft}$$

$$M = \frac{wl^2}{8} = \frac{(3.75 \text{ k/ft})(8ft)^2}{8} = 30 \text{ k-ft}$$

from FIGURE 7-6 $l = 8'$, $M = 30 \text{ k-ft}$.

lightest section - W 10 x 19
 acceptable sections - W 6 x 25
 W 8 x 20
 W 12 x 22

for W 10 x 19 section. $I = 96.3 \text{ in}^4$

$$\Delta = \frac{5wl^4}{384EI} = \frac{5(3.75 \text{ k/ft})(96 \text{ in})^4}{384(29 \times 10^3 \text{ ksi})(96.3 \text{ in}^4)} = 0.124 \text{ in}$$

CASE 3 -

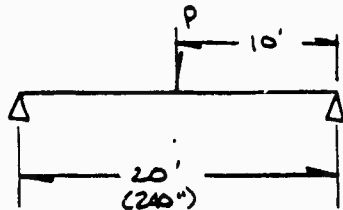

$$P = 30 \text{ k}$$

$$M = \frac{Pl}{4} = \frac{(30 \text{ k})(20 \text{ ft})}{4} = 150 \text{ ft-k}$$

from FIGURE 7-7 $l = 20'$, $M = 150 \text{ ft-k}$

lightest section - W 14 x 61
 acceptable sections - W 16 x 64
 W 21 x 68

for W 14 x 61 - $I = 641 \text{ in}^4$

$$\Delta = \frac{Pl^3}{48EI} = \frac{(30 \text{ k})(240 \text{ in})^3}{48(29 \times 10^3 \text{ ksi})(641 \text{ in}^4)} = 0.465 \text{ in}$$

CASE 4-

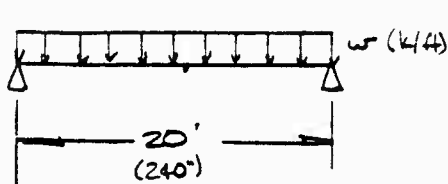

$$w = \frac{30k}{20ft} = 1.50 k/ft$$

$$M = \frac{wl^2}{8} = \frac{(1.50 k/ft)(20 ft)^2}{8} = 75 ft-k$$

From FIGURE 7-6 $l = 20 ft$, $M = 75 ft-k$

lightest section = W12x40
 acceptable section = W14x43

for W12x40 - $I = 310 in^4$

$$\Delta = \frac{5wl^4}{384EI} = \frac{5(1.25 k/in)(240 in)^4}{384(29 \times 10^3 ksi)(310 in^4)} = .601 in$$

CASE 5-

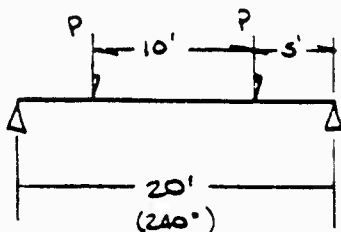

$$P = 30k$$

$$M = Pa = (30k)(5ft) = 150 ft-k$$

From FIGURE 7-8 $l = 20 ft$, $M = 150 ft-k$

lightest section = W14x61
 acceptable sections = W16x64
 W21x68

for W14x61 - $I = 641 in^4$

$$\Delta = \frac{Pa}{24EI} (3l^2 - 4a^2) = \frac{(30k)(60in)}{24(29 \times 10^3 ksi)(641 in^4)} \left[3(240)^2 - 4(60)^2 \right]$$

$$= .639 in$$

ALLOWABLE MOMENTS IN BEAMS

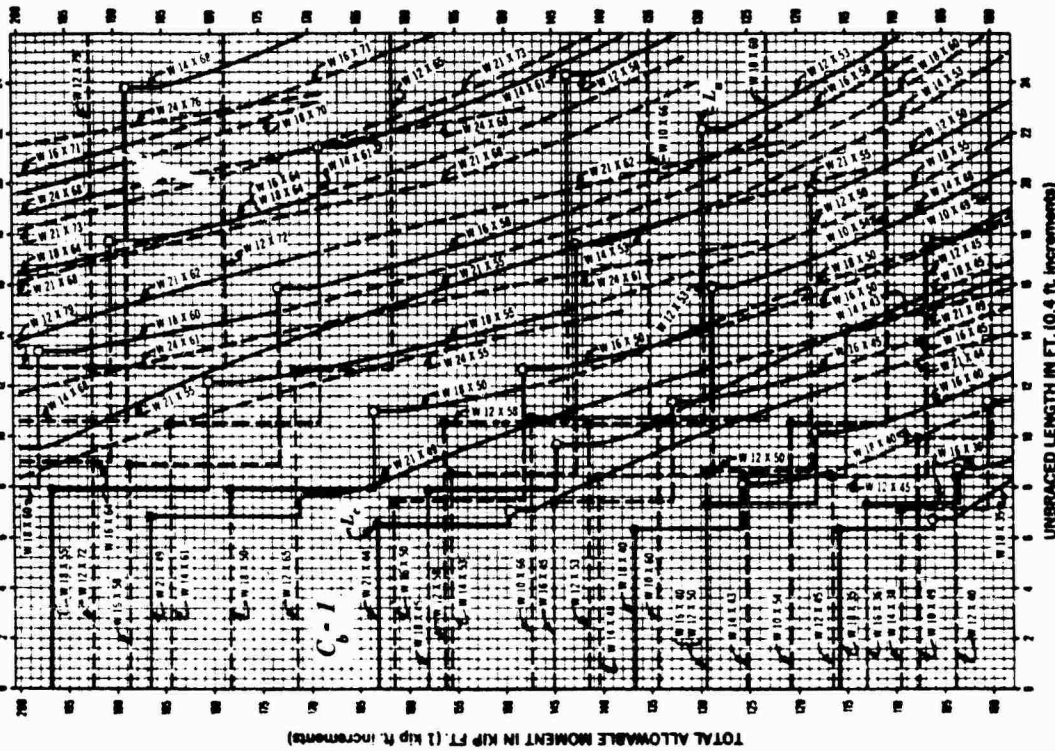

ALLOWABLE MOMENTS IN BEAMS

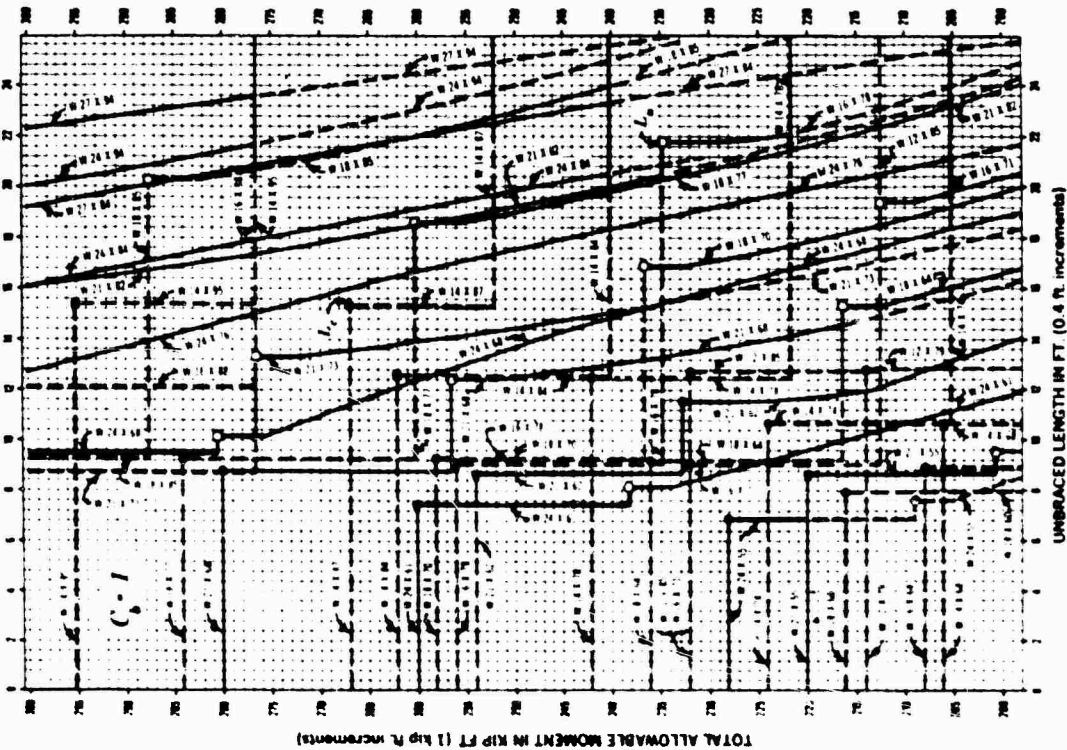

COURTESY OF AMERICAN INSTITUTE OF STEEL CONSTRUCTION
Figure 7-7. Allowable beam moments

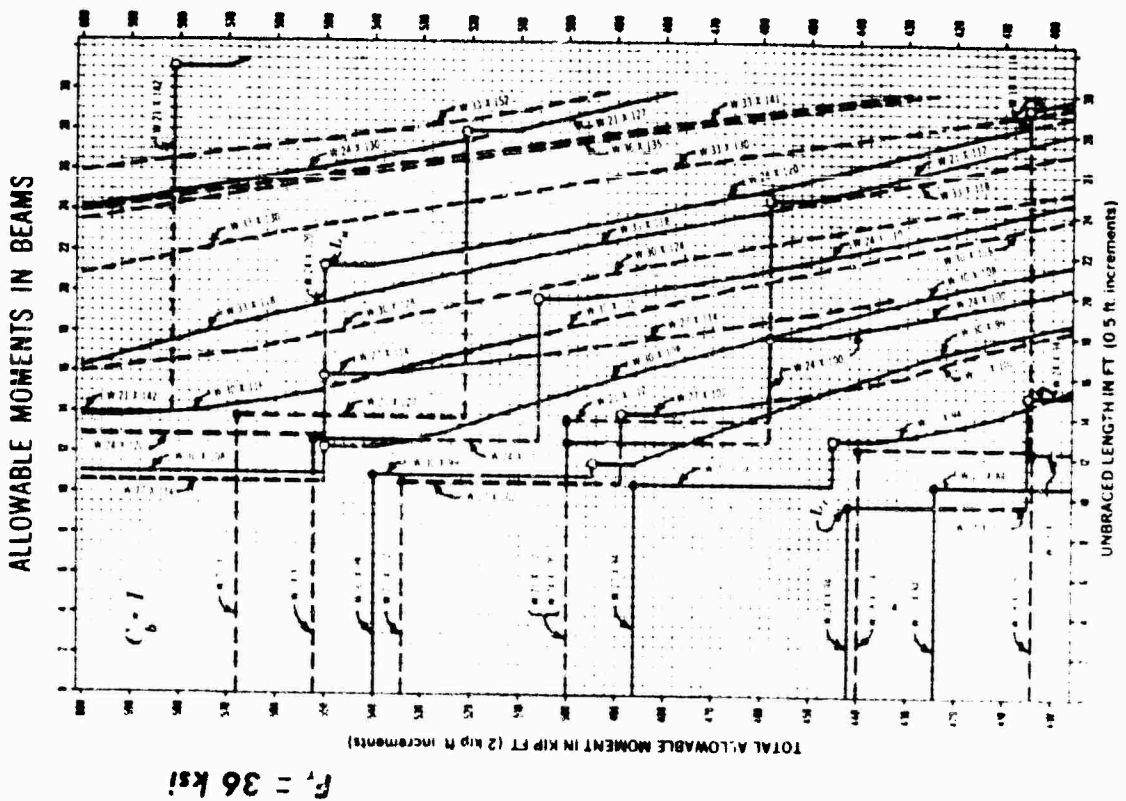
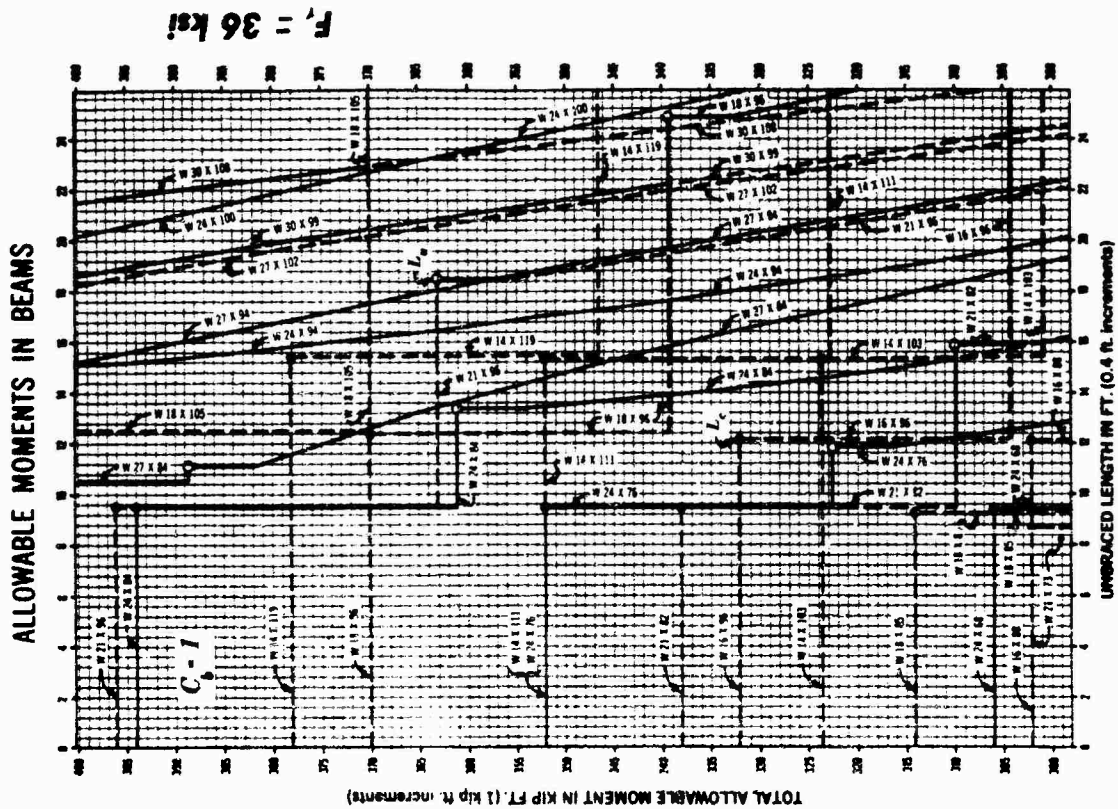

COURTESY OF AMERICAN INSTITUTE OF STEEL CONSTRUCTION

Figure 7-8. Allowable beam moments

ALLOWABLE MOMENTS IN BEAMS

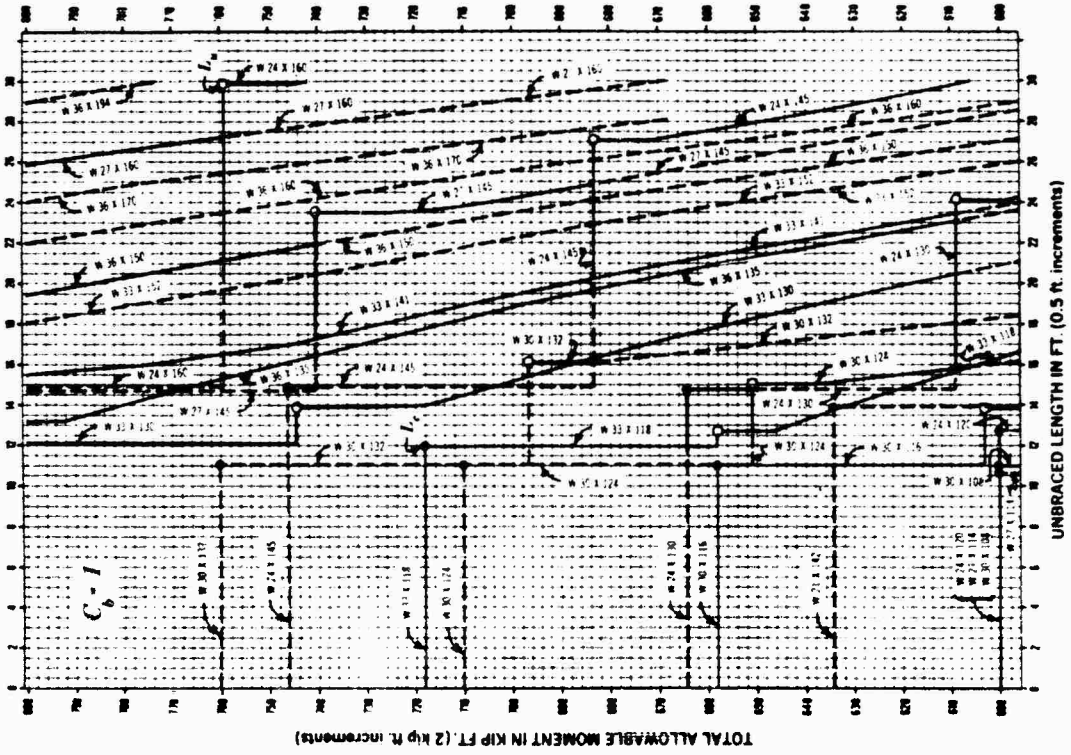

$F_y = 36 \text{ ksi}$

ALLOWABLE MOMENTS IN BEAMS

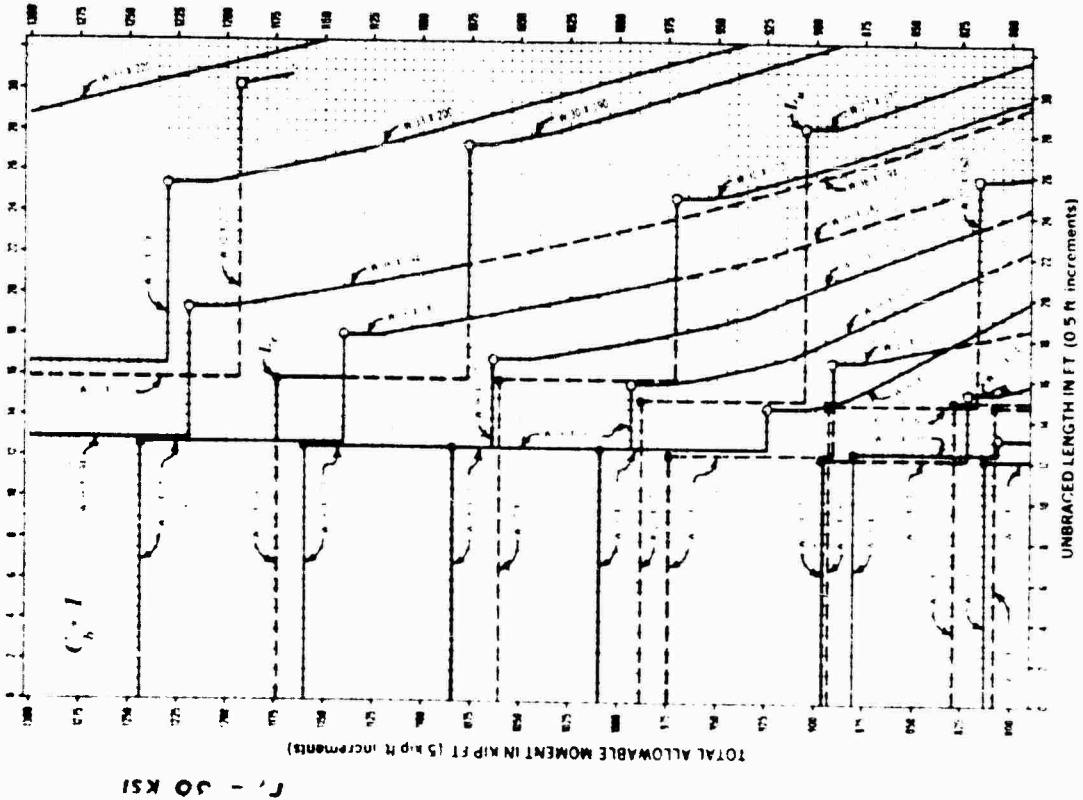

$F_y = 50 \text{ KSI}$

COURTESY OF AMERICAN INSTITUTE OF STEEL CONSTRUCTION

Figure 7-9. Allowable beam moments

7.5 Sheet Piles

7.5.1 Expedient Sheet Piling

Concept: This concept utilizes several steel shapes in conjunction with wood planking to form expedient sheet piling.

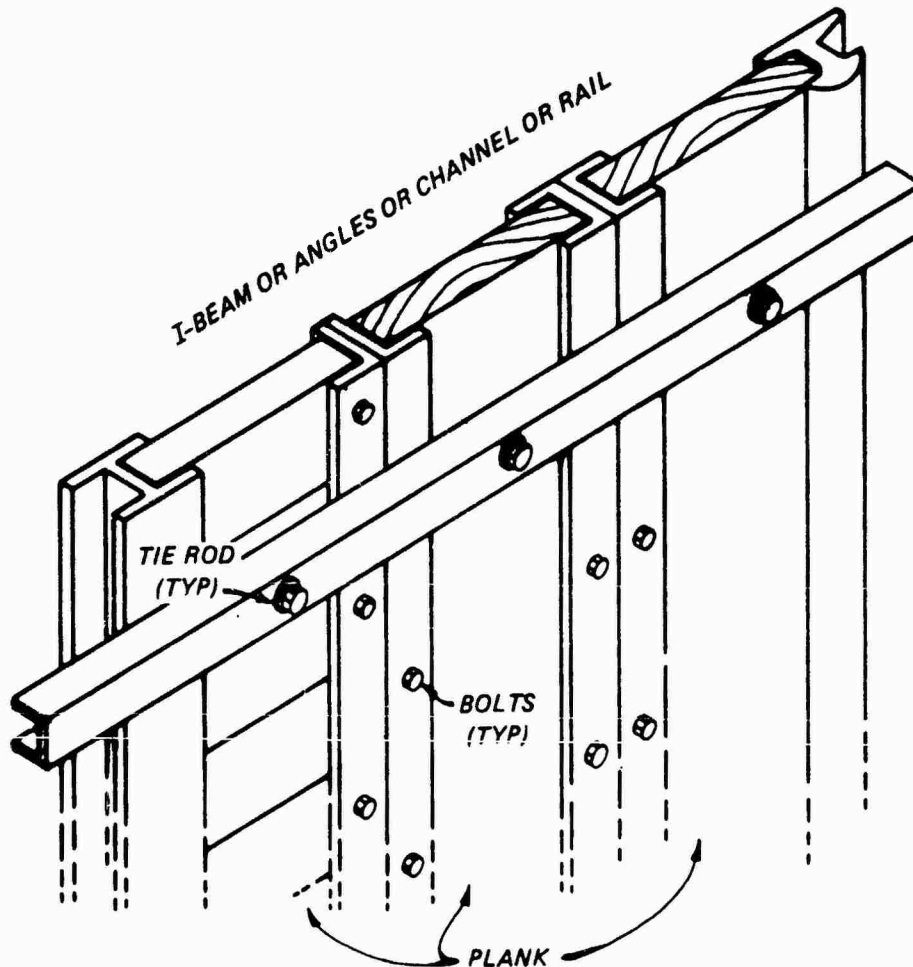

EXPEDIENT SHEET PILING

Description: Expedient sheet piling can be fabricated by using wood planks and available structural steel shapes as shown in the figure. The structural shapes are used between the planks to act as couplings. Since this is expedient sheet piling, it does not have the strength to be driven into the soil. A trench is excavated several feet below the soil surface and the expedient sheet piles are inserted. The trench is then backfilled and deadman lines are attached to the face of the piles to prevent overturning (see Figure 7-10).

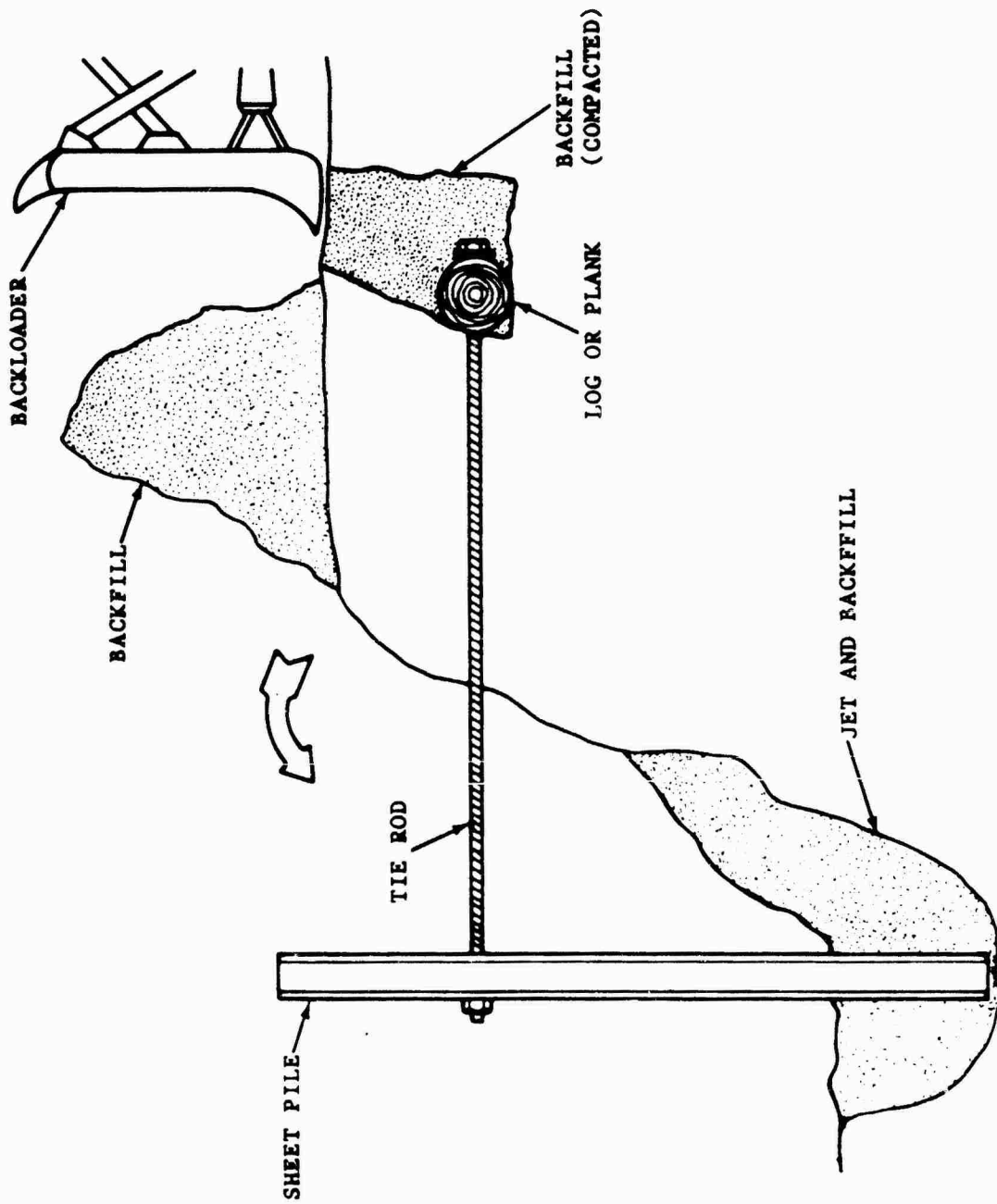
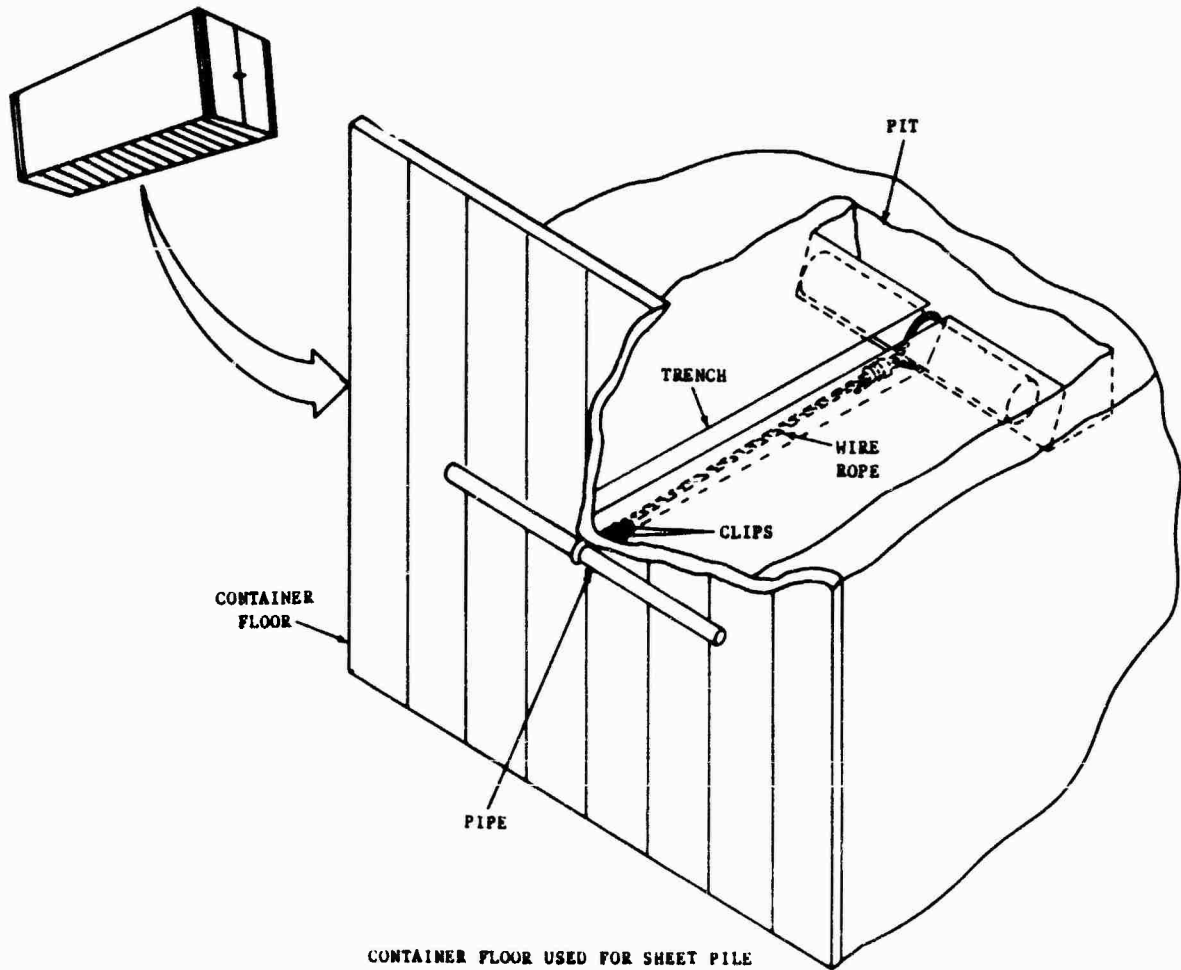

Figure 7-10. Sheet pile supported by deadman

7.5.2 Container Floor Used as Sheet Piling

Concept: This concept utilizes the floor of an ISO container as an expedient sheet pile.



Description: The floor of a 20 ft ISO container can be cut away and used to provide an 8 ft by 20 ft section of sheet piling. Tie rods or wire rope connect the expedient sheet piling to deadmen, anchored well behind the repair area (see Figure 7-10). This expedient sheet piling is not driven, but is placed in a trench and backfilled.

7.5.3 Timber Sheet Piling

Concept: This concept utilizes wood planks fastened together to fabricate sheet pile sections.

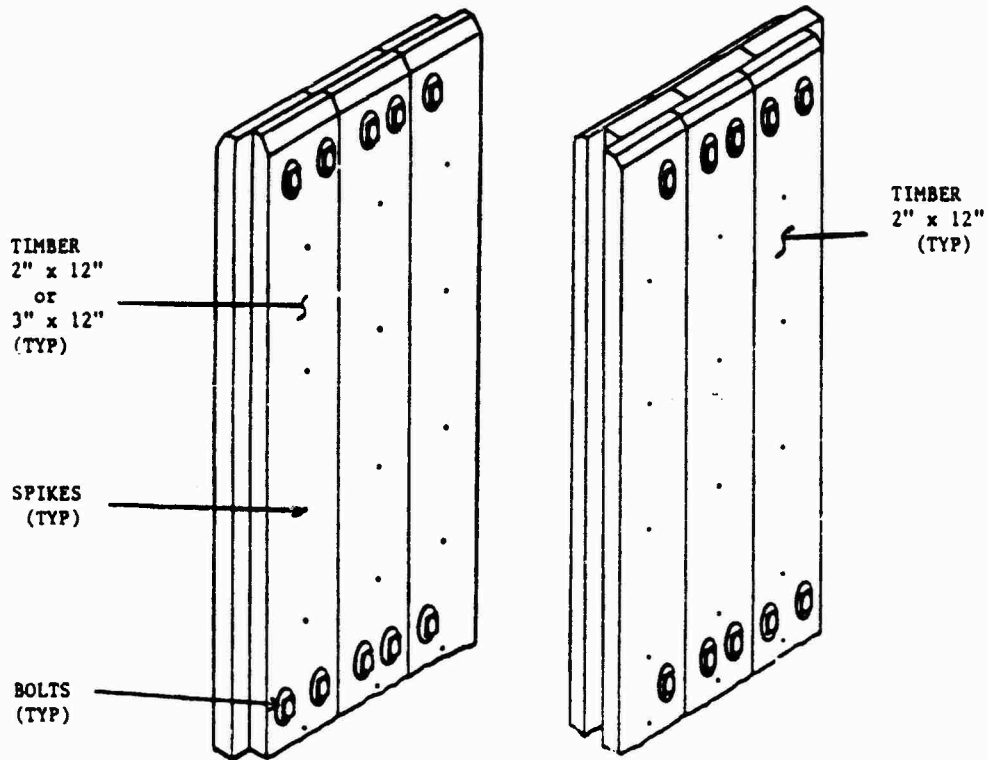

TIMBER SHEET PILING

Description: When wood planks are available, they can be screwed or bolted together to form sheet pile sections. These sections can be assembled together, as shown above, to provide a wall that will retain fill material on wharves or quays. The sheet piling may be fabricated using two layers of 2 by 12 in. or 3 by 12 in. planks, or by using three layers if greater strength. The expedient sheet piles are placed into a trench and restrained from overturning by lines from deadmen.

7.5.4 Patching A Steel Sheet Pile Section

Concept: This concept utilizes a metal patch and grouting to repair a damaged steel sheet pile.

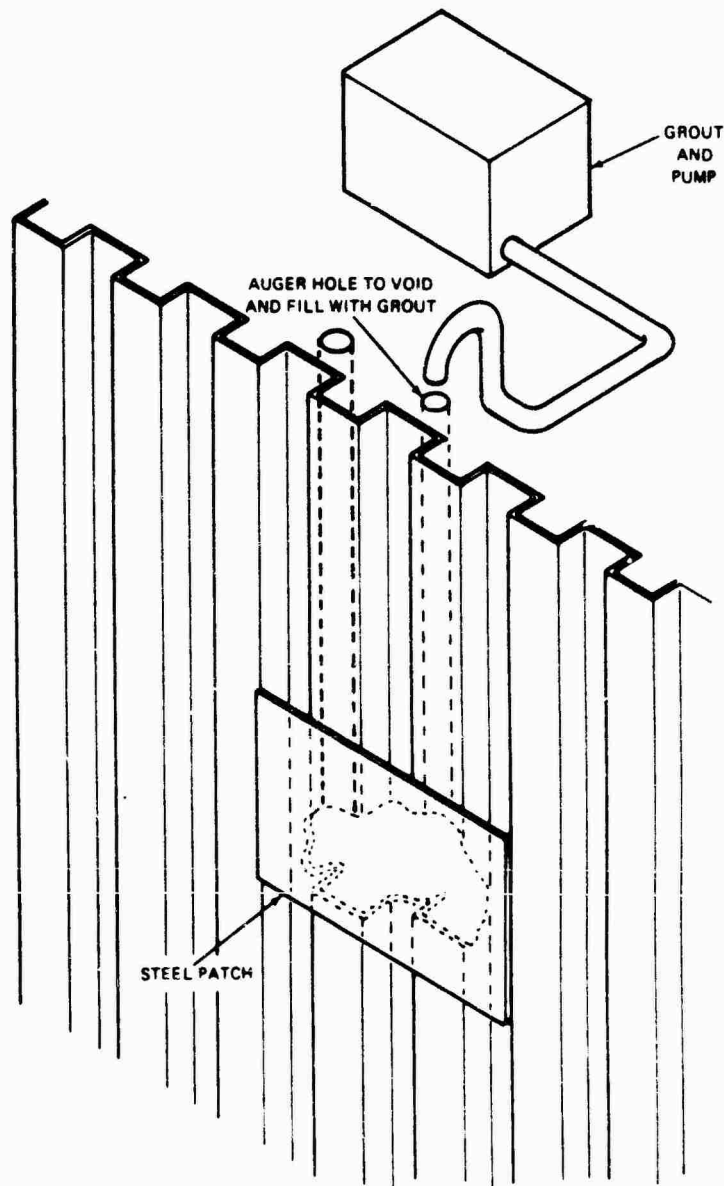

SHEET PILING REPAIR

Description: This repair plugs a hole in a section of steel sheet piling. A steel patch is placed over the damaged area and screwed in place. Wooden blocks are inserted into any cavities created by the piling shape and metal patch. Two holes are augered down to the void as shown in the figure. Grout is tremied into the void until all the water is displaced.

7.6 Trusses

7.6.1 Timber Truss

Concept: This concept utilizes a timber truss to replace a damaged pile using two neighboring undamaged piles. No additional foundation is necessary.

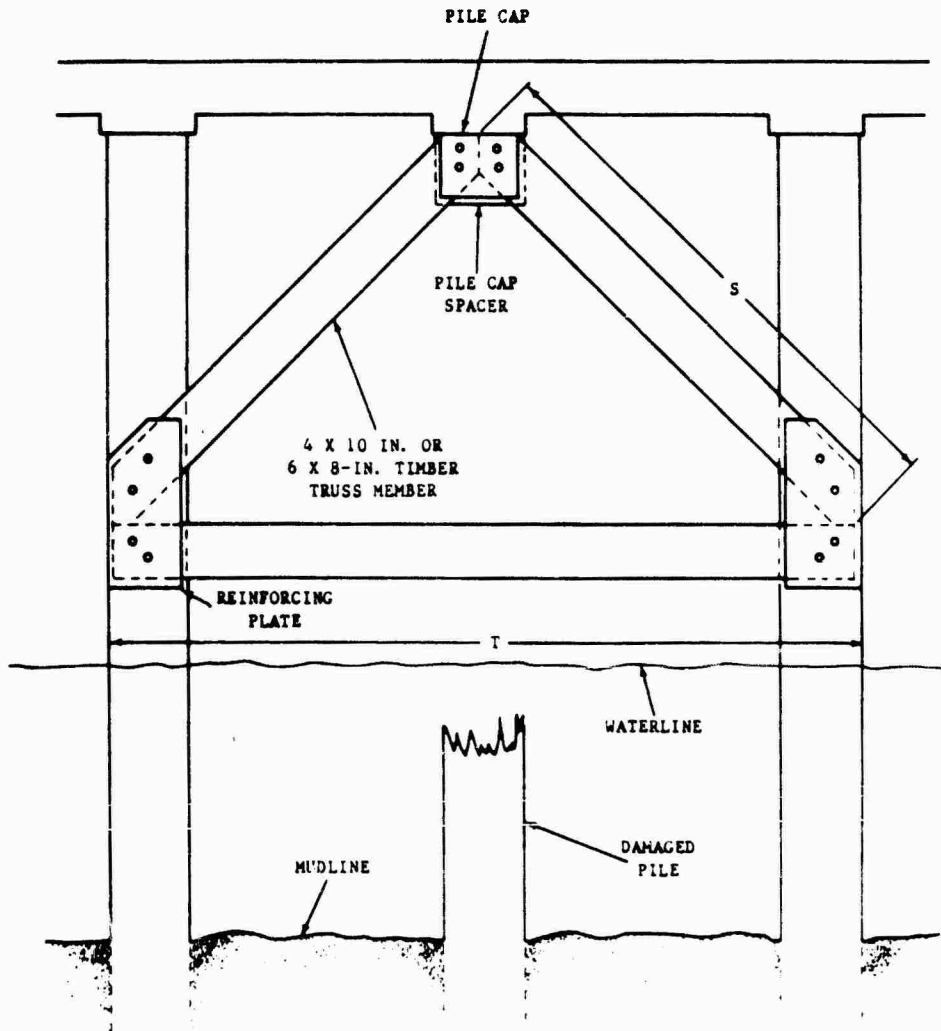

TIMBER TRUSS

Description: This repair method replaces a damaged pier pile with a timber truss. The truss members run from the pile cap to adjoining undamaged piles. The truss repair is actually two trusses, attached on both sides of the adjoining piles. This technique transfers the load from the damaged pile to its sound adjacent piles. Because these neighbor piles are now supporting a greater load, this affected area of the pier must be derated to two-thirds of its initial load capacity. The truss members are sized to meet tension and compression forces, and to resist buckling. This method can be used to replace timber or steel pipe piles.

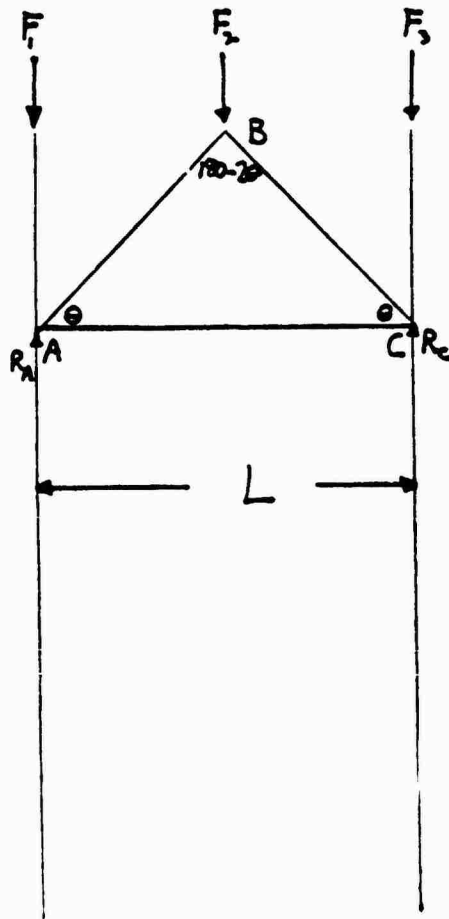

FORCE DIAGRAM FOR TIMBER TRUSS

CALCULATIONS FOR FORCES IN MEMBERS AB, BC, AND AC

$$F_1 = F_2 = F_3 = F$$

$$\downarrow \sum M_A = 0 = F\left(\frac{L}{2}\right) + F(L) - R_c(L)$$

$$F\left(\frac{L}{2} + L\right) = R_c(L)$$

$$F\left(\frac{3}{2}L\right) = R_c(L)$$

$$F\left(\frac{3}{2}\right) = R_c$$

$$\underline{R_c = \frac{3}{2}F}$$

$$\downarrow \sum F_y = 0 = F + F + F - \frac{3}{2}F - R_A$$

$$3F - \frac{3}{2}F = R_A$$

$$\frac{3}{2}F = R_A$$

$$\underline{R_A = \frac{3}{2}F}$$

$$R_A = R_c = \frac{3}{2}F$$

FORCE IN MEMBER AB = ?

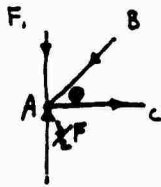

$$\downarrow \sum F_y = 0 = F - \frac{3}{2}F + F_{AB} \sin \theta$$

$$F_{AB} \sin \theta = \frac{F}{2}$$

$$F_{AB} = \frac{F}{2 \sin \theta} \quad (\text{COMPRESSION})$$

FORCE IN MEMBER AC = ? $\downarrow \sum F_x = 0 = -F_{AC} + F_{AB} \cos \theta$

$$+F_{AC} = +F_{AB} \cos \theta$$

$$F_{AC} = \frac{F \cos \theta}{2 \sin \theta} = \frac{F}{2} \cot \theta \quad (\text{TENSION})$$

ASSUME: COMPRESSION PARALLEL TO GRAIN = 1250 PSI
TENSION PARALLEL TO GRAIN = 1000 PSI

THEREFORE IF: F IS FORCE IN POUNDS

A IS MEMBER CROSS SECTIONAL AREA IN SQUARE INCHES FOR WOOD

THEN: FOR MEMBERS AB + BC, $\frac{F}{A 2 \sin \theta} < 1250 \text{ psi}$

FOR MEMBER AC, $\frac{F \cot \theta}{A 2} < 1000 \text{ psi}$

Example: The pile to be repaired is an 8 in. diameter timber pile. The center to center spacing of the pier piles is 5 ft. The truss angle is to be 45 deg. The truss members are to be 4 by 8 in. timbers.

a. From Table 7-1, the maximum load for this 8 in. timber pile is found to be 16 tons, or 32,000 lb.

b. The slenderness ratio, L/r , for the compression members is found as follows:

$$\text{length of member} = 5 \text{ ft} / \cos 45 = 7.07 \text{ ft} = 84.8 \text{ in.}$$

$$r = 4.0 \text{ in.}$$

$$L/r = 84.8 \text{ in.} / 4.0 \text{ in.} = 21.2$$

c. The maximum allowable stress in compression for a wood compression member is 1,250 psi. The force in these members is found using:

$$F = (P/2)/2 \sin 45 = (32,000/2)/2 \sin 45 = 11,314 \text{ lb}$$

The stress is found using:

$$\text{Stress} = F/A = 11,314 \text{ lb} / (4)(8) \text{ sq in.} = 354 \text{ psi} < 1,250 \text{ psi}$$

d. The force in the member in tension is to be less than 1,000 psi for wood and is found using:

$$F = (P/2) \cot 45/2 = (32,000/2) \cot 45/2 = 8,000 \text{ lb}$$

The tensile stress in this member is:

$$\text{Stress} = F/A = 8,000 \text{ lb} / (4)(8) \text{ sq in.} = 250 \text{ psi} < 1,000 \text{ psi}$$

Since both of these conditions are met, these members can be used.

Truss connecting methods for the adjoining piles and pile cap are shown in Figures 7-11 and 7-12.

The affected expedient repair area must be derated to two-thirds of the original capacity. The deck must be conspicuously marked and signs posted stating that this area is derated. These limits will prevent the supporting piles used in this repair from being overloaded.

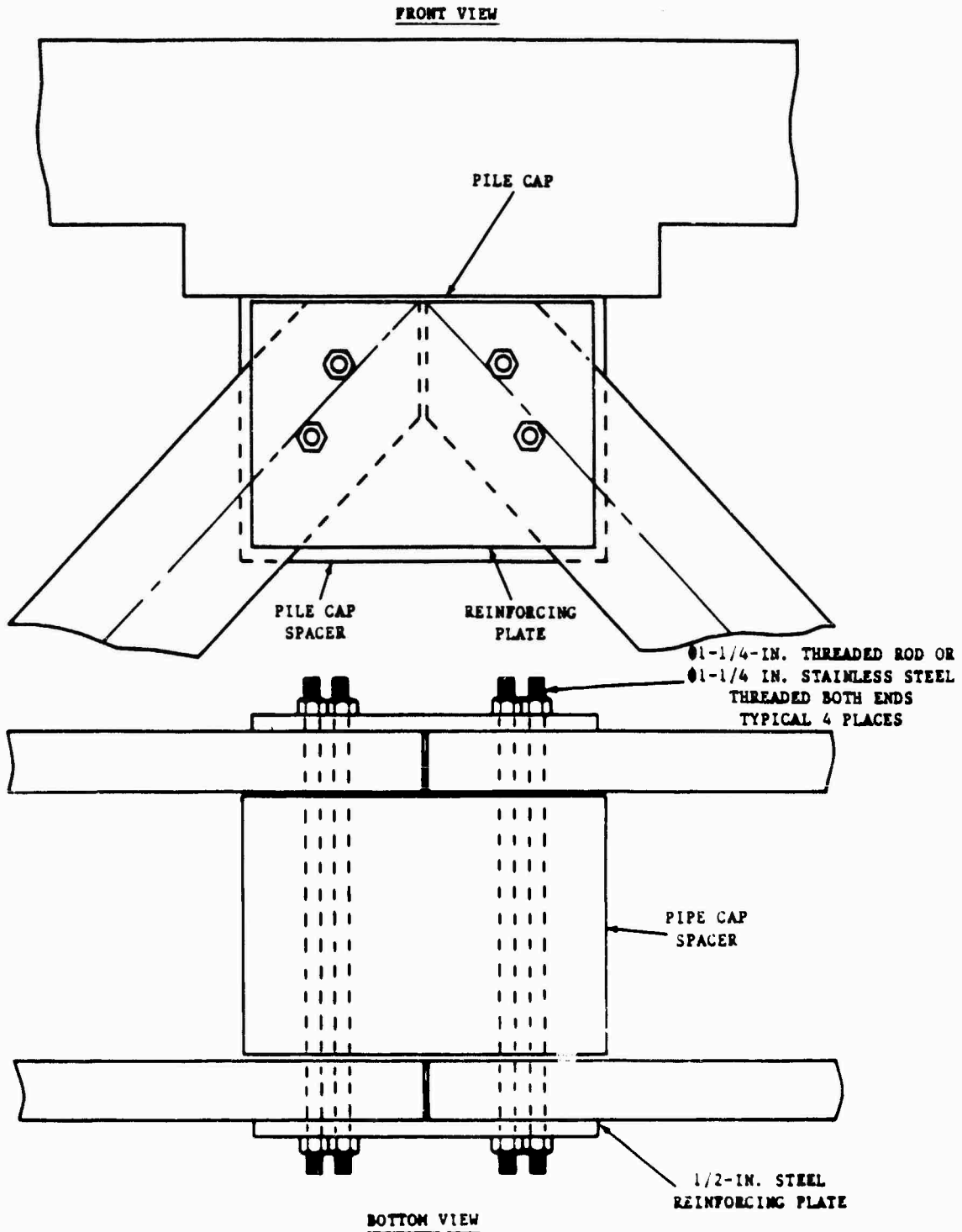

Figure 7-11. Timber truss pile cap connection

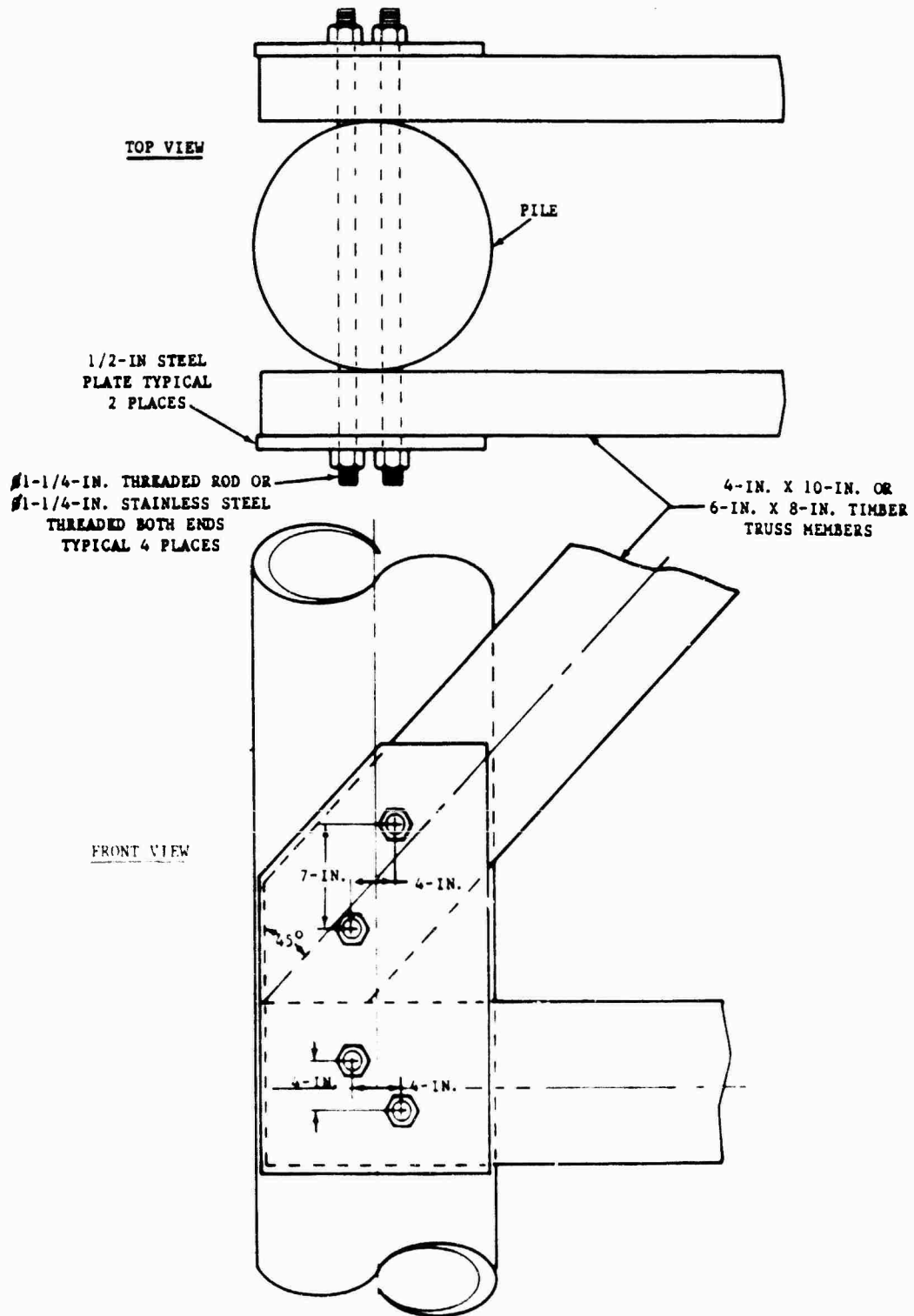
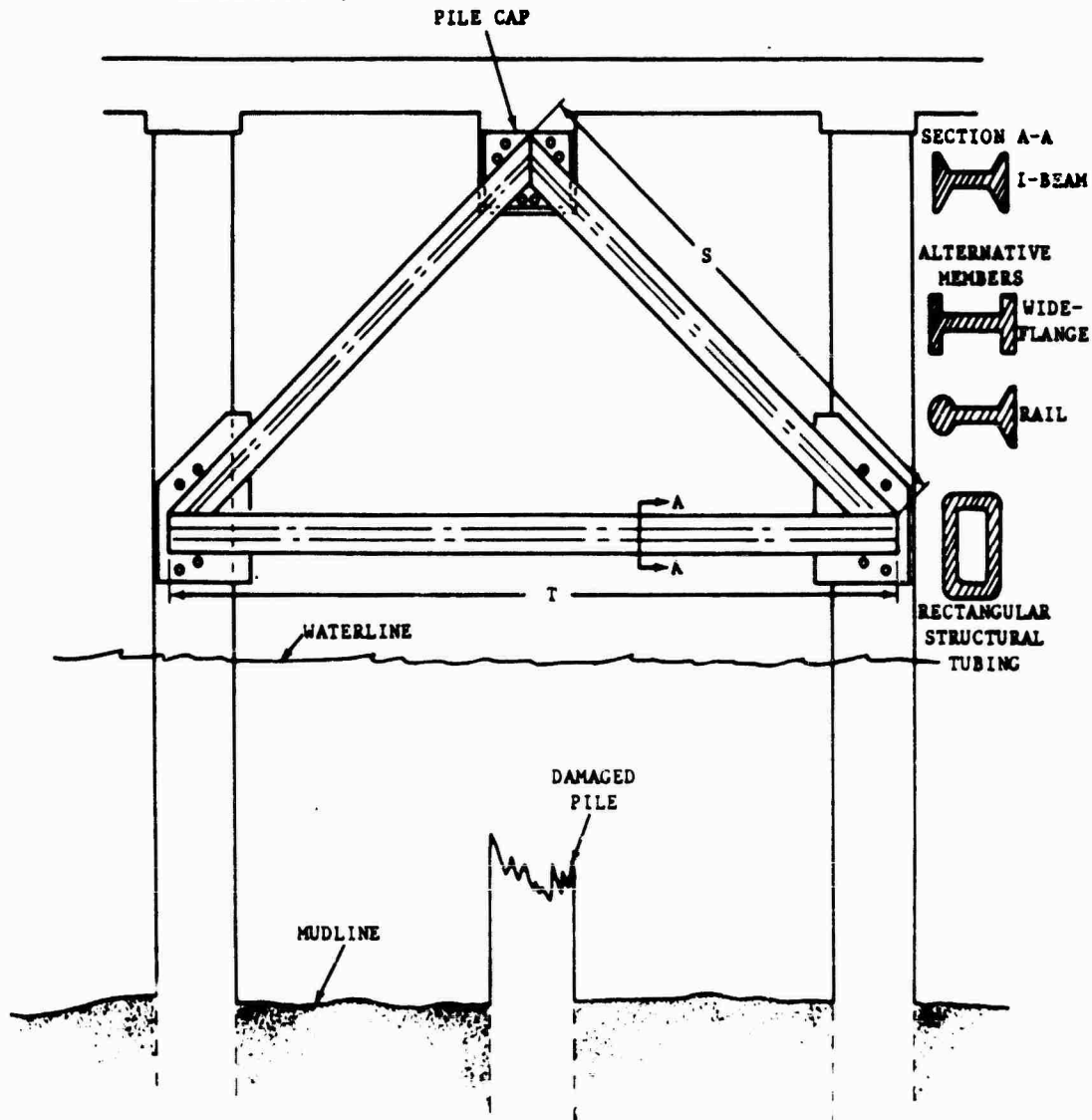

Figure 7-12. Timber truss pile connection

7.6.2 Steel Truss

Concept: This concept utilizes a steel truss to replace a damaged pile using two neighboring undamaged piles. No additional foundation is necessary.



STEEL TRUSS

Description: This repair method replaces a damaged pier pile with a steel truss. The truss members run from the pile cap to adjoining undamaged piles. The truss repair is actually two trusses attached on both sides of the adjoining piles. This technique transfers the load from the damaged pile to its sound adjacent piles. Because these neighbor piles are now supporting a greater load, this affected area of the pier must be derated to two-thirds of its initial load capacity. The truss members are sized to meet tension compression forces and to resist buckling. This method can be used to replace timber or steel pipe piles.

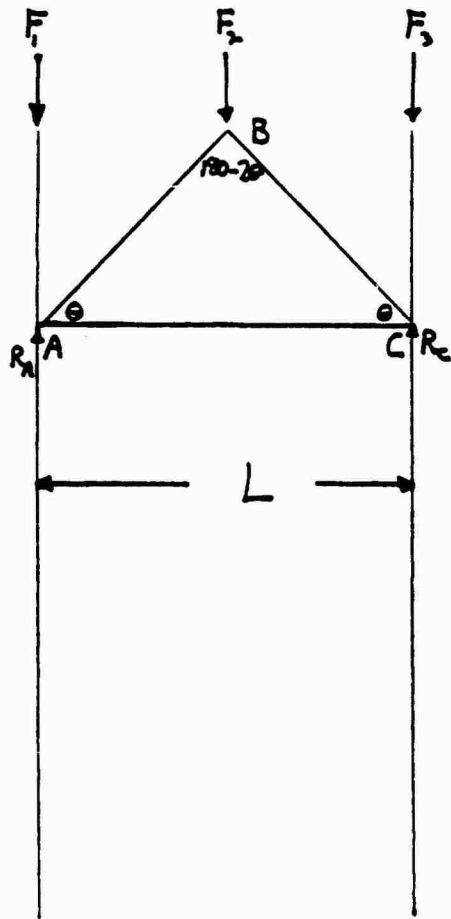

FORCE DIAGRAM FOR STEEL TRUSS

CALCULATIONS FOR FORCES IN MEMBERS AB, BC, AND AC

$$F_1 = F_2 = F_3 = F$$

$$\uparrow \sum M_A = 0 = F\left(\frac{L}{2}\right) + F(L) - R_c(L)$$

$$= F\left(\frac{L}{2} + L\right) - R_c(L)$$

$$= F\left(\frac{3}{2}L\right) - R_c(L)$$

$$= F\left(\frac{3}{2}\right) = R_c$$

$$\underline{R_c = \frac{3}{2}F}$$

$$\uparrow \sum F_y = 0 = F + F + F - \frac{3}{2}F - R_A$$

$$= 3F - \frac{3}{2}F = R_A$$

$$= \frac{3}{2}F = R_A$$

$$\underline{R_A = \frac{3}{2}F}$$

$$\underline{R_A = R_c = \frac{3}{2}F}$$

FORCE IN MEMBER AB = ?

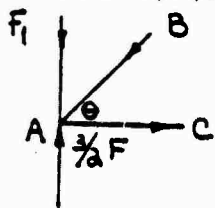

$$\uparrow \sum F_y = 0 = F - \frac{3}{2}F + F_{AB} \sin \theta$$

$$= F_{AB} \sin \theta = \frac{F}{2}$$

$$= F_{AB} = \frac{F}{2 \sin \theta} \quad (\text{COMPRESSION})$$

FORCE IN MEMBER AC = ? $\rightarrow \sum F_x = 0 = -F_{AC} + F_{AB} \cos \theta$

$$+F_{AC} = +F_{AB} \cos \theta$$

$$F_{AC} = \frac{F \cos \theta}{2 \sin \theta} = \frac{F}{2} \cot \theta \quad (\text{TENSION})$$

ASSUME: COMPRESSION = VALUE FROM TABLE 7-8

TENSION = 20,000 PSI

THEREFORE IF: F IS FORCE IN POUNDS

A IS MEMBER CROSS-SECTIONAL AREA IN INCHES² (STEEL)

THEN:

FOR MEMBERS AB + BC, $\frac{F}{A \sin \theta} < \text{VALUE FROM TABLE 7-8}$

FOR MEMBER AC, $\frac{F}{A} \cot \theta < 20,000 \text{ PSI}$

Example: The pile to be repaired is a 14 in. diameter steel pipe. The center to center spacing of the pier piles is 7 ft. The truss angle is to be 45 deg. The potential truss members are to be S 12 by 50.0"I" Beams.

- a. From Table 7-1, the maximum load for this 14 in. steel pile is found to be 42 tons.
- b. The slenderness ratio, L/r , for the compression members is found as follows:

$$\begin{aligned} \text{length of member} &= 7 \text{ ft} / \cos 45 = 9.9 \text{ ft} = 118.8 \text{ in.} \\ r &= 1.03 \text{ in. (from Tables 7-2 through 7-7)} \\ L/r &= 118.8 \text{ in.} / 1.03 \text{ in.} = 115.3 \end{aligned}$$

From Table 7-8, the maximum allowable stress in compression for a slenderness ratio of 115 is 10,990 psi.

- c. The force in these members is found using:

$$F = (P/2)/2 \sin 45 = (84,000/2)/2 \sin 45 = 29,698 \text{ lb}$$

The stress is found using:

$$\text{Stress} = F/A = 29,698 \text{ lb} / 9.35 \text{ sq in.} = 3,176 \text{ psi} < 10,990 \text{ psi}$$

- d. The force in the member in tension is to be less than 20,000 psi and is found using:

$$F = (P/2)\cot 45/2 = (84,000/2)\cot 45/2 = 21,000 \text{ lb}$$

The tensile stress in this member is:

$$\text{Stress} = F/A = 21,000 \text{ lb} / 9.35 \text{ sq in.} = 2,246 \text{ psi} < 20,000 \text{ psi}$$

Since both of these conditions are met, these members can be used.

Truss connecting methods for the adjoining piles and pile cap are shown in Figures 7-13 and 7-14.

The affected expedient repair area must be derated to two-thirds of the original capacity. The deck must be conspicuously marked and signs posted stating that this area is derated. These limits will prevent the supporting piles used in this repair from being overloaded.

Note: Steel channel should not be used in this simple truss because of the lengths of the members involved. Since the least radius of gyration for all common channel sizes between 3 and 15 in. is under 1.00, the slenderness ratio limits the very best member to under 10 ft in length.

Table 7-6. Rectangular Structural Tubing Properties

Rectangular Structural Tubing			
<u>Size, in.</u>	<u>Wall Thickness, in.</u>	<u>Cross-Section Area, sq in.</u>	<u>Least Radius of Gyration, in.</u>
8X3	0.500	9.14	1.13
8X4	0.500	10.10	1.53
8X6	0.375	9.33	2.34
	0.500	11.90	2.27
10X4	0.375	9.33	1.62
	0.500	11.90	1.56
10X6	0.313	9.19	2.45
	0.375	10.80	2.41
	0.500	13.90	2.35
10X8	0.250	8.48	3.23
	0.313	10.40	3.20
	0.375	12.30	3.16
	0.500	15.90	3.10
12X4	0.313	9.19	1.68
	0.375	10.80	1.65
	0.500	13.90	1.59
12X6	0.250	8.48	2.53
	0.313	10.40	2.50
	0.375	12.30	2.47
	0.500	15.90	2.40
12X8	0.250	9.48	3.30
	0.313	11.70	3.27
	0.375	13.80	3.24
	0.500	17.90	3.18

Table 7-7. Square Structural Tubing Properties

Square Structural Tubing			
Size, in.	Wall Thickness, in.	Cross-Section Area, sq in.	Radius of Gyration, in.
6X6	0.375	7.95	2.26
	0.500	10.10	2.19
7X7	0.313	7.94	2.69
	0.375	9.33	2.65
8X8	0.500	11.90	2.58
	0.313	9.19	3.10
	0.375	10.80	3.06
10X10	0.500	13.90	2.99
	0.625	16.80	2.91
	0.250	9.48	3.95
	0.313	11.70	3.92
	0.375	13.80	3.88
	0.500	17.90	3.81
	0.625	21.80	3.74

Table 7-8. Allowable Stress, in Ksi, for Compression
Members of A36 Steel

Main and Secondary Members, Kl/r not more than 120					Main Members, Kl/r, 121-200				
$\frac{Kl}{r}$	Fa	$\frac{Kl}{r}$	Fa	$\frac{Kl}{r}$	Fa	$\frac{Kl}{r}$	Fa	$\frac{Kl}{r}$	Fa
1	21.56	41	19.11	81	15.24	121	10.14	161	5.76
5	21.39	45	18.78	85	14.79	125	9.55	165	5.49
10	21.16	50	18.35	90	14.20	130	8.84	170	5.17
15	20.89	55	17.90	95	13.60	135	8.19	175	4.88
20	20.60	60	17.43	100	12.98	140	7.62	180	4.61
25	20.28	65	16.94	105	12.33	145	7.10	185	4.36
30	19.94	70	16.43	110	11.67	150	6.64	190	4.14
35	19.58	75	15.90	115	10.99	155	6.22	195	3.93
40	19.19	80	15.36	120	10.28	160	5.83	200	3.73

FRONT VIEW

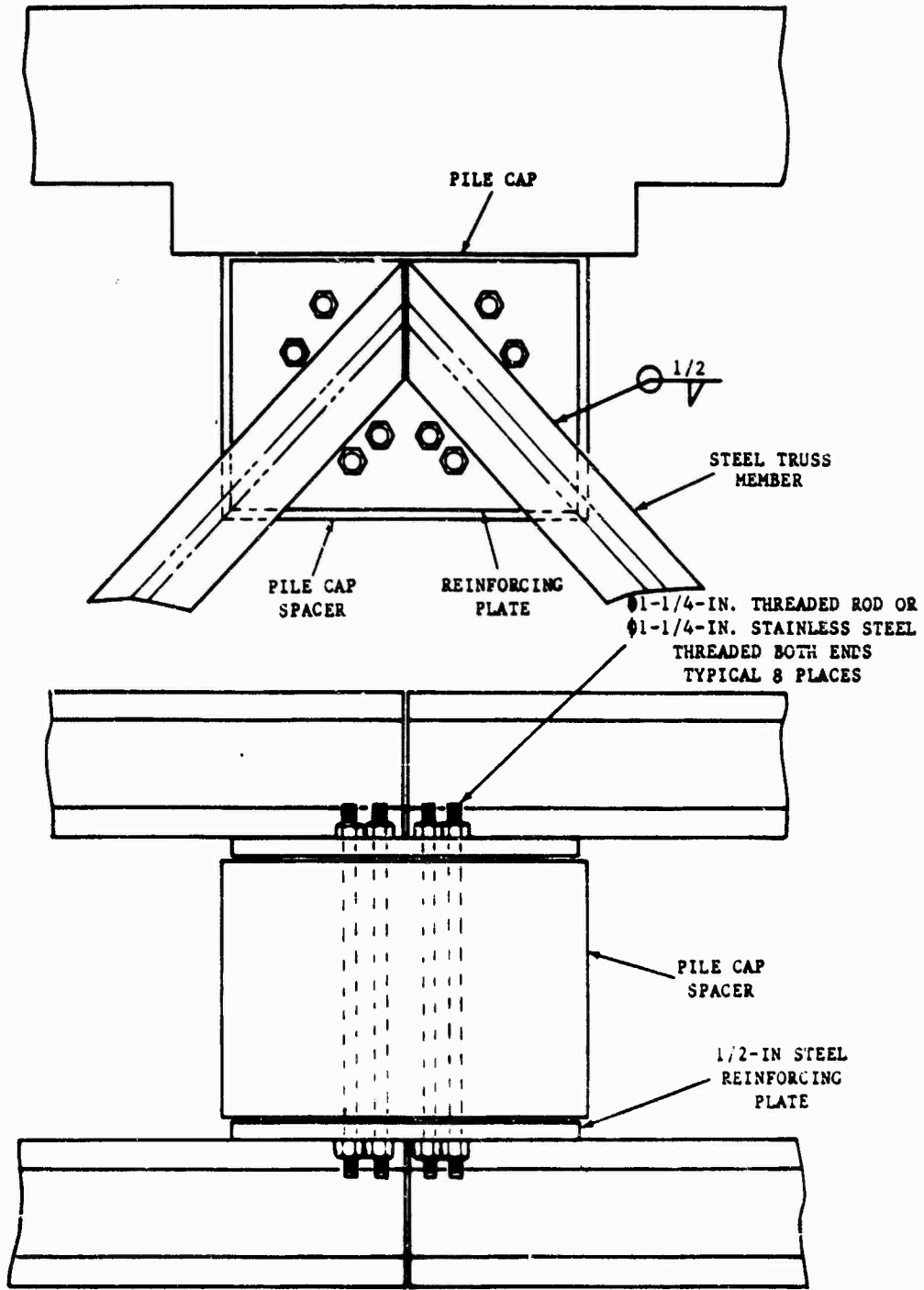

BOTTOM VIEW

Figure 7-13. Steel truss pile cap connection

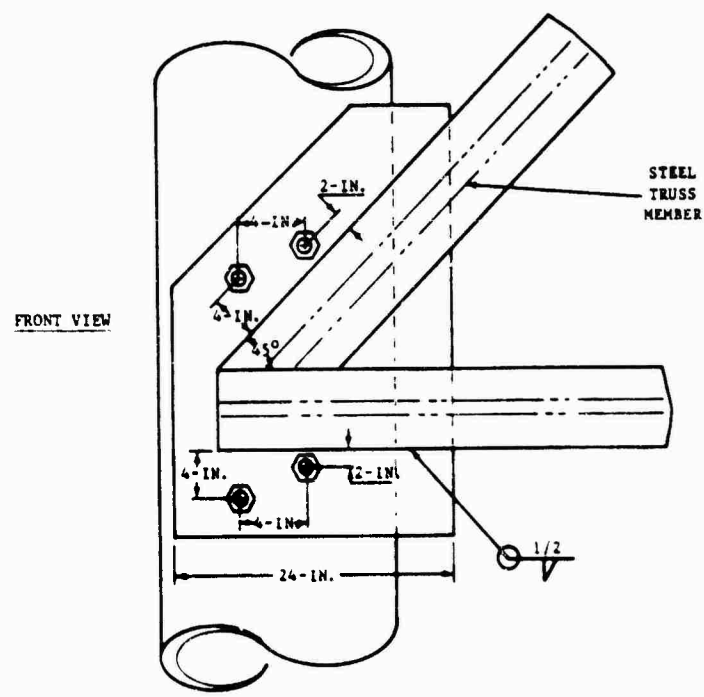
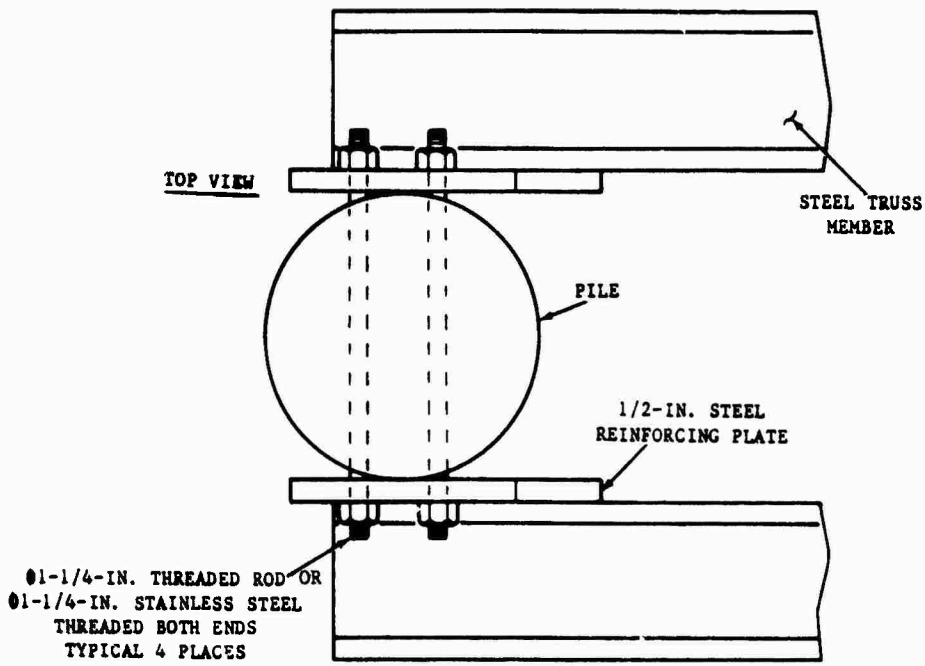
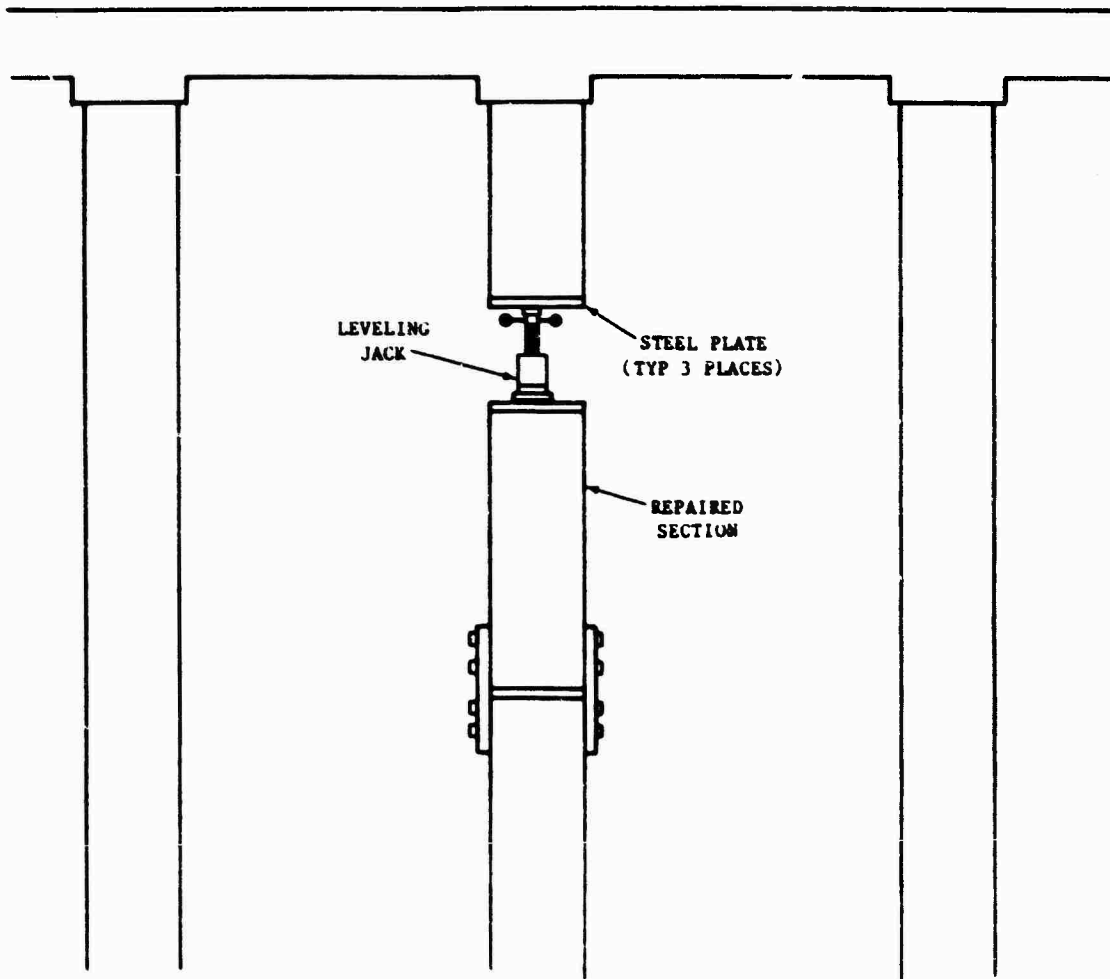

Figure 7-14. Steel truss pile connection

7.7 Other Salvaged Materials

7.7.1 Leveling Jack Repair

Concept: This concept utilizes a jack to shore up a sagging deck, or to span a short distance between a pile of insufficient length and the pile cap.



USING A LEVELING JACK TO SPAN
EXISTING PILE AND REPAIRED SECTION.
(35 TON MAXIMUM)

Description: This repair uses a 35-ton leveling jack (screw type) to span a gap between the pile and cap, or between two sections of the pile. It could be used to fill the void between the pile and the cap due to settling of the pile below. This repair method could also be used to span the gap caused by a pile that had been replaced with a column of insufficient length.

8.0 Repair Concepts for Decking to Support Interface

This section gives suggested techniques for connecting the replacement column to the pile cap and foundation, and methods of bracing the column into position.

8.1 Bracing Methods

Bracing is applied to the support structure repair area to resist lateral loads. These loads result from mooring, wind, current, and wave forces (see Tables 8-1 to 8-4). Transverse bracing is typically 4 by 8 in. or 4 by 10 in. timbers. Bracing is applied diagonally and attached to each pile with a single 3/4 in. bolt. Normally, transverse bracing has a vertical spread from the low water line to the lower edge of the cap.

8.2 Connecting Methods

Connecting methods are suggested as ideas in Tables 8-5 to 8-11 with the final connection dependant upon the replacement pile materials, connecting materials available, and logistics of the particular repair. Tables 8-5 to 8-8 are connecting methods which can be used as column to base or cap connections. Tables 8-9 to 8-11 present ideas for column to base connections.

Table 8-1. Connecting Brace to Timber or Steel Pipe Pile,
Bracing Method 1

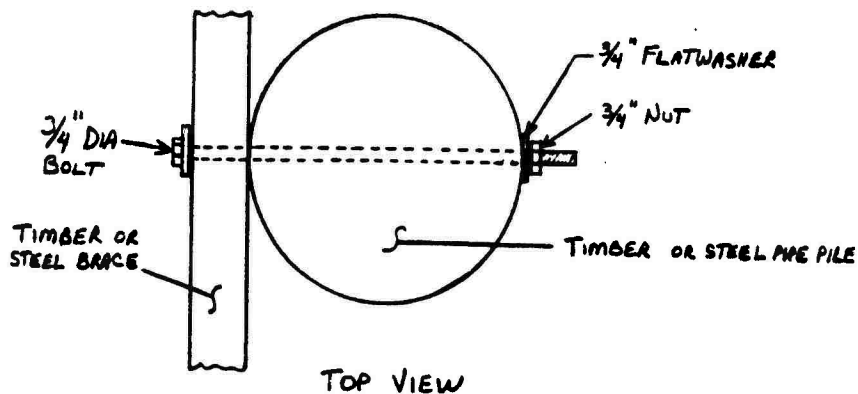

Applications	
Column	Brace
Timber	Timber
Timber	Steel
Steel Pipe	Timber
Steel Pipe	Steel

Materials:	
Qty	Description
1	3/4" dia. bolt; * length = pile dia. + 6"
2	3/4" flat washer
2	3/4" nuts

* bolt length where two braces cross
replacement pile = pile dia. + 12"

Requirements:

1. Connection area must be free of loose debris.
2. One bolt is used per connection.
3. Preferably all fasteners are galvanized steel, and threaded rod may be used.

Procedure:

1. If timber pile, drill through diameter of pile.
2. If steel pipe pile, drill or torch a hole through diameter of pile.
3. Attach brace to pile with bolt, nut, and washers.

Table 8-2. Connecting Brace to Steel Beam Pile, Bracing Method 2

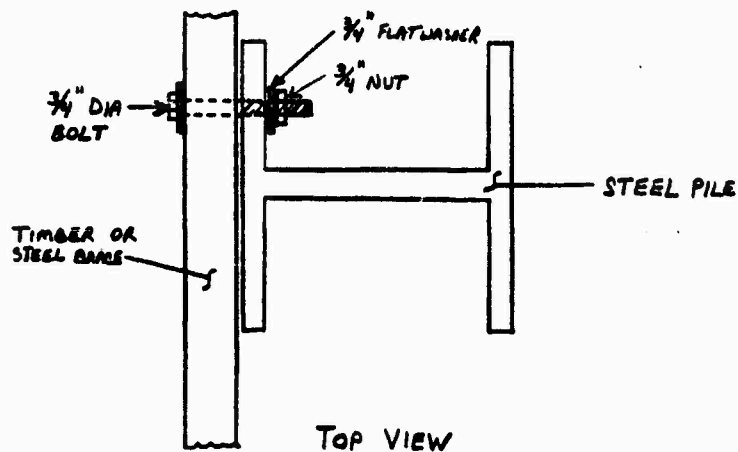

Applications	
Column	Brace
Steel Beam	Timber
Steel Beam	Steel

Materials:	
Qty	Description
1	3/4" dia. bolt; length - flange thickness + 6"
2	3/4" flat washers
2	3/4" nuts

Requirements:

1. Connection area must be free of loose debris.
2. One bolt is used per connection.
3. Preferably all fasteners are galvanized steel, and threaded rod may be used.

Procedure:

1. Drill or torch a hole through flange of beam.
2. Attach brace to pile with bolt, nut and washers.

Table 8-3. Connecting Brace to Concrete Pile with External Bracket,
Bracing Method 3

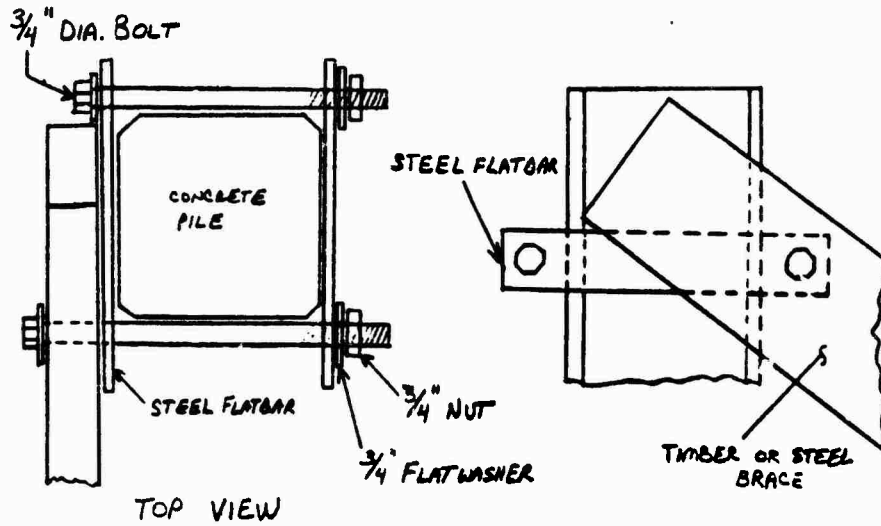

Applications	
Column	Brace
Concrete	Timber
Concrete	Steel

Materials:	
Qty.	Description
2	3/8" x 3" steel; length = pile dia. +4"
1	3/4" dia. bolt; length = pile dia. +4"
1	3/4" dia. bolt; length = pile dia. +8"
4	3/4" nuts
4	3/4" flat washers

Requirements:

1. Connection area must be free of loose debris
2. One brace bracket is used per connection.
3. Preferably all fasteners are galvanized steel, and threaded rod may be used.

Procedure:

1. Drill two holes in each steel flatbar, 1 1/4" from each end.
2. Attach brace to pile using the brace bracket, bolts, nuts, and washers.

Table 8-4. Connecting Brace to Concrete Pile with Concrete Anchor,
Bracing Method 4

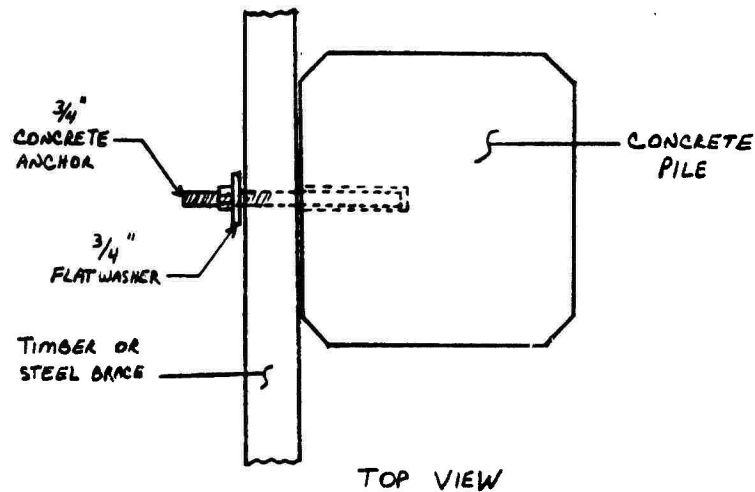

Applications	
Column	Brace
Concrete	Timber
Concrete	Steel

Materials:	
Qty.	Description
1	3/4" dia. concrete anchor
1	3/4" flat washer

Requirements:

1. Connection area must be free of loose debris.
2. One concrete anchor is used per connection.
3. Bracing Method 3 is the preferred method of connecting a brace to concrete.

Procedure:

1. Drill required hole in concrete pile
2. Attach brace to pile with concrete anchor and flat washer.

Table 8-5. Joining Like-Diameter Piles, Column to Base or Cap Connections, Connecting Method 1

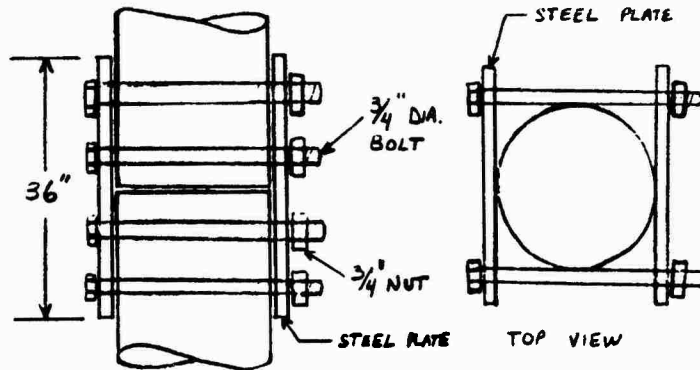

Applications:	
Column	Base or Cap
Steel Pipe	Steel Pipe
Steel Pipe	Timber
Steel Pipe	Concrete
Timber	Steel Pipe
Timber	Timber
Timber	Concrete

Materials:	
Qty.	Description
8	3/4" dia. bolts; length = Pile dia. + 5"
8	3/4" nuts
2	Steel plates; minimum dimensions: 1/2" x 36" lg. x (pile dia. + 6") wide.

Requirements:

1. Both diameters of the spliced connection must be the same.
2. Bolts must fit snugly along sides of column and base.
3. If either the column or base is a steel pipe, a 1/4" steel plate must be placed between the column and base or cap.
4. Preferably all fasteners are galvanized steel, and threaded rod may be used.

Procedure:

1. Drill steel plates to allow bolts to be installed along both sides of the base and the repair column.
2. Place repair column directly between the base and cap.
3. Loosely connect the two plates by installing four bolts only along one side.
4. Slip plates over the area to be spliced and insert the four remaining bolts through the two plates.
5. Evenly tighten the bolts and torque nuts to 100 ft-lb to complete the splice.

Table 8-6. Joining Like-Diameter Piles, Column to Base or Cap Connections, Connecting Method 2

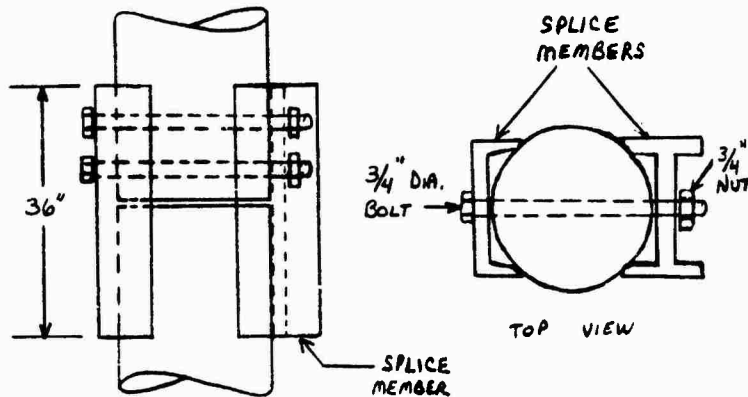

Applications:	
Column	Base or Cap
Steel Pipe	Steel Pipe
Steel Pipe	Timber
Steel Pipe	Concrete
Timber	Steel Pipe
Timber	Timber
Timber	Concrete

Materials:	
Qty.	Description
2	3/4" dia. bolts; length = pile dia. + 5"
2	3/4" dia. nuts
2	Splice members (minimum length = 36")
	Steel Channel C 10 x 20
	Steel I-Beam S 10 x 25.4

Requirements:

1. Both diameters of the spliced connection must be the same.
2. Steel channel or I-beam sections may be used as splice members.
3. If either the column or base is a steel pipe, a 1/4" steel plate must be placed between the column and base or cap.
4. Preferably all fasteners are galvanized steel, and threaded rod may be used.

Procedure:

1. Drill splice members and column through the center to accommodate the two 3/4" bolts by;
 - a. Drilling two holes through the column at least 6" from the column end and 6" apart,
 - b. Drilling two holes in splice members to match column holes.
2. Loosely bolt splice members to column.
3. Position the column directly between the base and cap with the splice members loosely over each side of the base/cap.
4. Torque nuts to 100 ft-lb to align column and base/cap and to complete the splice.

Table 8-7. Joining Like-Diameter Piles, Column to Base or Cap Connections, Connecting Method 3

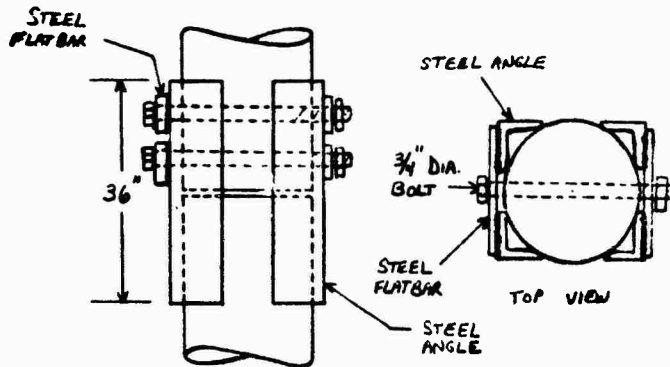

Applications:		Materials:	
Column	Base or Cap	Qty.	Description
Steel Pipe	Steel Pipe	2	3/4" dia. bolts; Length = Pile dia. + 5"
Steel Pipe	Timber	2	3/4" nuts
Steel Pipe	Concrete	4	Steel flat bar;
Timber	Steel Pipe	4	3/8" thick x 2" wide x length = pile dia.
Timber	Timber	4	Steel angle; minimum dimensions:
Timber	Concrete		3/8" thick x 4" x 4" x 36" long

Requirements:

1. Both diameters of the spliced connection must be the same.
2. If either the column or base is a steel pipe, a 1/4" steel plate must be placed between the column and base or cap.
3. Preferably all fasteners are galvanized steel, and threaded rod may be used.

Procedure:

1. Drill clearance holes through the center of each 3/8" x 2" steel flatbar to accommodate the 3/4" bolts.
2. Drill two holes through the column at least 3" from the column end and 3" apart.
3. Loosely place the 3/4" bolts through the steel flatbar, the column, and the flatbar on the other side of the column.
4. Install steel angle sections lengthwise along the column between the flatbar and the column, and tighten the bolts to hold the angles in place.
5. Weld flatbars to angles.
6. Loosen bolts.
7. Place column directly between the base and cap with the splice members loosely over each side of the base foundation.
8. Torque nuts to 100 ft-lb to align column and base/cap and to complete the splice.

Table 8-8. Joining Piles of Differing Diameters, Column to Base or Cap Connections, Connecting Method 4

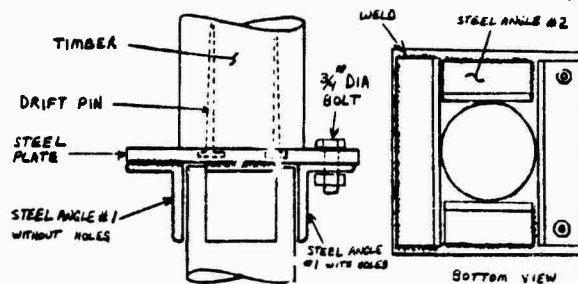

Applications:		Materials:	
Column	Base or Cap	Qty.	Description
Timber	Steel Pipe	2	3/4" dia bolts, 4 inches long
Timber	Timber	2	3/4" nuts
Timber	Concrete	2	drift pins
		2	steel angle #1; minimum dimensions: L 6 x 3 1/2 x 3/8 x (base pile dia. +7")lg.
		2	steel angle #2; minimum dimensions: L 6 x 3 1/2 x 3/8 x (base pile dia.) lg.
		1	steel square plate minimum dimensions: 1/4" thick, length = base foundation diameter + 7".

Requirements:

1. Welded angles must fit snugly along the sides of the base foundation or pile cap.

Procedure:

1. Drill clearance holes for two 3/4" dia. bolts through the shorter leg of one of the steel angles #1, 3" in from each end.
2. Lay the steel angle #1, holes down, on the steel plate, aligning the edges of the angle with the edge of the plate, and mark the location of the two bolt clearance holes.
3. Drill the two bolt clearance holes in the steel plate.
4. Drill and counter-bore holes in the steel plate for the drift pins.
5. Weld steel angle #1 without holes to the steel plate as shown in the drawing.
6. Weld steel angles #2 to steel plate as shown in the drawing.
7. Center plate on end of repair column and drive drift pins through the plate and into the column.
8. Position repair column directly between base pile and cap.
9. Bolt remaining steel angle #1 to the bottom of the steel plate to complete the splice.

Table 8-9. Joining Steel Column to Base Pile, Column to Base Connections, Connecting Method 5

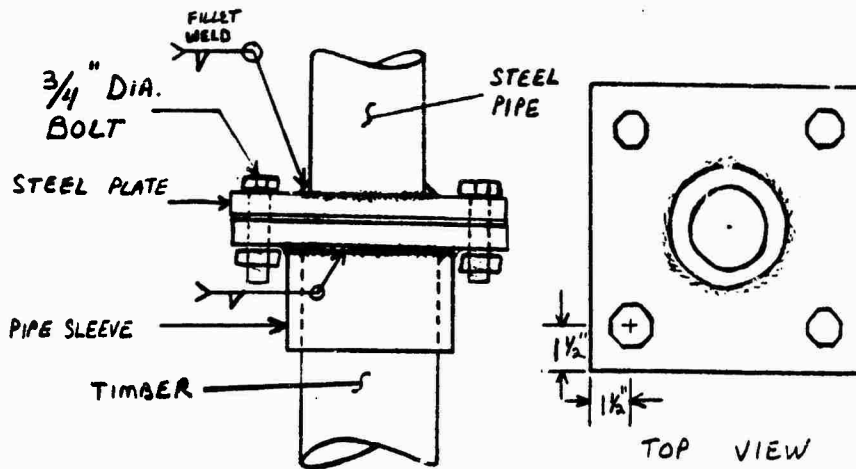

Applications:	
Column	Base
Steel	Timber
Steel	Steel Pile
Steel	Concrete

Materials:	
Qty.	Description
4	3/4" dia. bolts approximately 4" long
4	3/4" nuts
2	square steel plates; minimum dimensions: 1/4" thick, length = base pile dia. + 2"
1	Pipe sleeve; pipe I.D. = Base pile dia., length = 12"

Requirements:

1. Must be able to closely align repair column to base foundation in order to match bolt holes and install bolts.
2. Preferably all fasteners are galvanized steel.

Procedure:

1. Drill four 1" dia. holes in corners of top steel plate, 1 1/2" in and 1 1/2" down from each corner.
2. Drill four 1" dia. holes in corners of bottom steel plate to match holes in the top plate.
3. Center and weld steel pipe sleeve to bottom plate.
4. Center and weld steel pipe column to top plate.
5. Center bottom plate over base pile.
6. Place column directly between base and cap, align bolt holes and install four 3/4" bolts and nuts.
7. Torque nuts to 100 ft-lb to complete the splice.

Table 8-10. Joining Piles at the Ocean Floor with Concrete, Column to Base Connections, Connecting Method 6

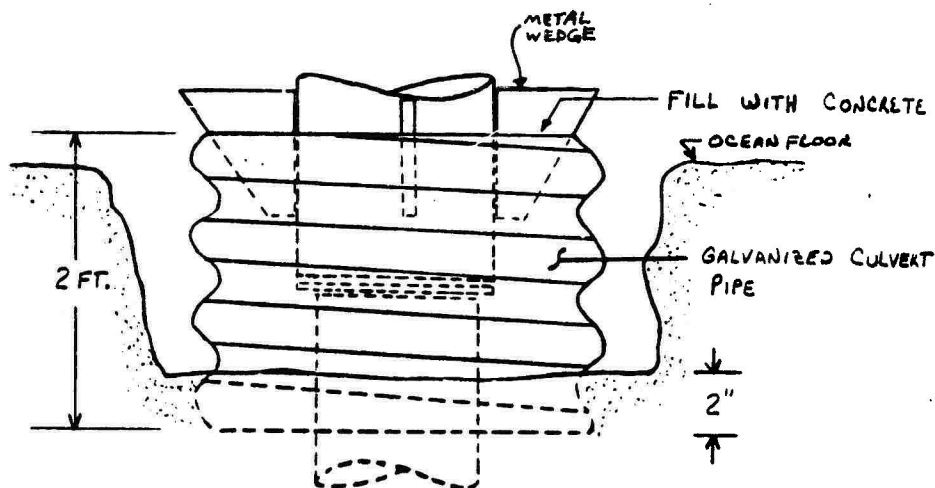

Applications:	
Column	Base
Steel	Steel
Steel	Timber
Steel	Concrete
Timber	Steel
Timber	Timber
Timber	Concrete

Materials:	
Qty.	Description
1	galvanized culvert pipe or oil drum/ends out minimum dimensions: diameter = largest pile diameter = 10", length = 2 feet
A/R	high early strength concrete
4	1/4" thick metal wedge

Requirements:

1. Splice is to be made below ocean floor.
2. If either the column or base is a steel pipe, or if repair column diameter is greater than the base pile diameter, a 1/4" steel plate must be placed between the column and base.

Procedure:

1. Place repair column through culvert pipe.
2. Place and hold repair column directly over base pile.
3. Lower culvert pipe over splice area and bury bottom two inches in the ocean floor.
4. Hold the repair column in place by inserting four metal wedges between the culvert pipe and the column.
5. Pump concrete into the space between culvert pipe and pile to complete the splice.

Table 8-11. Joining Piles at the Ocean Floor with Concrete, Column to Base Connections, Connecting Method 7

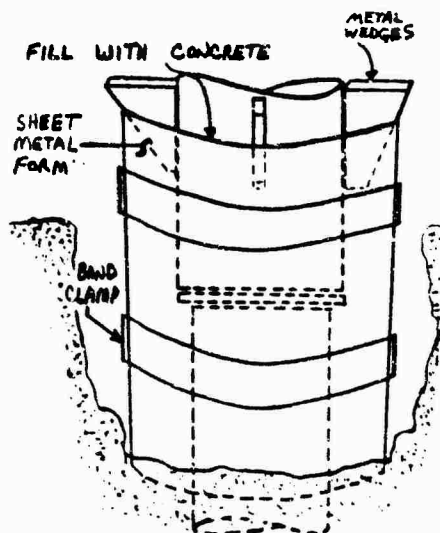

Applications:	
Column	Base
Steel	Steel
Steel	Timber
Steel	Concrete
Timber	Steel
Timber	Timber
Timber	Concrete

Materials:	
Qty.	Description
2	band clamps
1	sheet metal concrete form
A/R	high early strength concrete
4	1/4" thick metal wedge

Requirements:

1. Splice is to be made below the ocean floor.
2. If either the column or base is a steel pipe, or if repair column diameter is greater than the base pile diameter, a 1/4" steel plate must be placed between the column and base.

Procedure:

1. Position repair column directly above base foundation and hold in this position.
2. Concentrically locate sheet metal form around repair column and base and bury bottom two inches in the ocean floor.
3. Place band clamps around sheet metal form.
4. Hold the repair column in place by inserting four metal wedges between the metal form and the column.
5. Pump concrete into space between form and piles to complete the splice.

BIBLIOGRAPHY

- American Bureau of Shipping. 1974. "Rules for Certification of Cargo Container." N.Y.
- Banneister, T., Avallone, E. D., and Baumeister, T. III. 1978. Marks Standard Handbook for Mechanical Engineers, 8th Ed., McGraw-Hill Book Co., N.Y.
- Browers, J. T. 1977. Guide to Underwater Explosive Excavation, 1st Ed., J. T. Brower and Associates, Pomona, Calif.
- Budynas, R. G. 1977. Advanced Strength and Applied Stress Analysis, 1st Ed., McGraw-Hill Book Co., N.Y.
- Cement and Concrete Association. 1963 (Dec). Technical Report UDC 666.9.022.7:551.464: 666.9.017:539.4:666.9.015.3: The Workability and Compressive Strength of Concrete Made with Seawater, by J. D. Dewar.
- Construction Engineering Research Laboratory. 1977 (Jul). Technical Report C-77: Shipping Containers as Structural Systems, by E. L. McDowell. Champaign, Ill.
- Headquarters, Department of the Army. 1964 (Sep). TM 5-360: Port Construction and Rehabilitation. Washington, D.C.
- _____. 1968 (Oct). TM 5-725: Rigging. Washington, D.C.
- _____. 1968 (Dec). TM 5-312: Military Fixed Bridges. Washington, D.C.
- _____. 1973 (Mar). TM 9-1375-213-12: Operators and Organizational Maintenance Manual; Demolition Materials. Washington, D.C.
- _____. 1976 (Sep). FM 5-34: Engineer Field Data. Washington, D.C.
- _____. 1984 (Feb). FM 9-15: Explosive Ordnance Disposal Service and Unit Operations. Washington, D.C.
- _____. 1985 (Apr). FM 5-134: Pile Construction. Washington, D.C.
- _____. 1986 (Mar). FM 5-25: Explosives and Demolitions. Washington, D.C.
- Headquarters, Department of the Navy. 1980 (Nov). Facilities Engineering Command Design Manual 25.1 (With Change 1): Piers and Wharves. Alexandria, Va.
- Headquarters, Department of the Navy, Naval Facilities Engineering Command. 1983 (Oct). NAVFAC P-405: Seabee Planners and Estimators Handbook. Alexandria, Va.

Headquarters, Departments of the Army, the Navy, and the Air Force. 1978 (Jun). Army TM 5-622, Navy MO 104, Air Force AFM 91-34: Maintenance of Waterfront Facilities, Department of Defense. Washington D.C.

Jahren, C. T. "Evaluation and Repair of War-Damaged Port Facilities, Report 3; Concepts for Expedient War-Damage Repair of Pier and Wharf Decking," Technical Report (in preparation), US Army Engineer Waterways Experiment Station, Vicksburg, Miss.

Muvdi, B. B. and McNabb, J. W. 1963. Engineering Mechanics of Materials, 1st Ed., Macmillan Publishing Co., N.Y.

Myers, J. J., Holm, C. H., and McAllister, R. F. 1969. Handbook of Ocean and Underwater Engineering, 1st Ed., McGraw-Hill Book Co., N.Y.

Naval Facilities Engineering Command Construction. 1981 (Jan). Construction Diver Lift Systems - A Zero Milestone Report, by Lt. D. A. Vidal, CEC, USN. Port Hueneme, Calif.

Oberg, E., Jones, F. D., and Horton, H. L. 1976. Machinery Handbook, 20th Ed., 2nd Printing, New Industrial Press, Inc.

Rinaldi, J. 1972. Containerization: The New Method of Intermodal Transport, 1st Ed., Sterling Publishing Co., Inc., N.Y.

Smith, C. J. 1986. "Evaluation and Repair of War-Damaged Port Facilities, Report 1; Port Construction History, Inspection Techniques, and Major Port Characteristics," Technical Report GL-86-6, US Army Engineer Waterways Experiment Station, Vicksburg, Miss.

Smith, et al. "Evaluation and Repair of War-Damaged Port Facilities, Report 2; Port Vulnerability, Pier and Wharf Repair, and Storage Area Repair," Technical Report (in preparation), US Army Engineer Waterways Experiment Station, Vicksburg, Miss.

Urquhart, L. C. 1959. Civil Engineering Handbook, 4th Ed., New York, McGraw-Hill Book Co., N.Y.

US Naval Civil Engineering Laboratory. 1969 (Feb). TR R-613: Mix Designs for Fast-Fix Concrete. Port Hueneme, Calif.

_____. 1983 (Mar). Evaluation of Construction Diver Lift Systems, by H. Thomson, G. Bryant, and F. Barrett. Port Hueneme, Calif.

_____. 1984 (Oct). NCEL TM-43-85-01: O & M U>C T> Conventional Inspection and Repair Techniques Manual, by Han-Padron Associates of New York, Port Hueneme, Calif.

_____. 1985 (Mar). Handbook for Marine Geotechnical Engineering, by K. Rolker, Jr. Port Hueneme, Calif.

APPENDIX A: EXPEDIENT CUTTING ELECTRODE FABRICATION

Ultrathermic cutting is an excellent method to cut concrete, steel, or most any other material. Temperatures of up to 10,000° Fahrenheit can be obtained through the oxygenated burning electrodes. This type of system has been marketed under the name of BROCO BURN BARS, but expedient ultrathermic electrodes can also be fabricated that will give very high temperatures for cutting.

In situations where ultrathermic cutting systems are available, and the supply of ultrathermic electrodes has been expended, improvised emergency tubular electrodes may be fabricated from local supplies. These electrodes can be made from tubing or pipe by using 5/16 in. heavy wall steel tubing or 1/8 in. extra strong iron pipe in 14 in. lengths. The entire electrode, except for the grip end, is covered and firmly secured with one of the following materials:

1. Three wraps of masking tape
2. Four wraps of newspaper
3. Three wraps of ordinary wrapping paper
4. Three wraps of writing paper
5. Heat shrinkable tubing

Waterproofing should be applied by dipping the covered electrodes in lacquer, varnish, shellac, paint, or wax.

Other types of emergency cutting electrodes can also be fabricated. Among these are a brass tube of 3/8 in. inside diameter covered with friction tape, into which is driven a 1/4 in.-square cast-iron welding rod, another is a 3/8- or 1/4 in.-pipe that is 14 in. long and covered with welding electrodes that have been soldered, tack welded, or brazed into the bore to ensure good electrical contact between the electrodes and the pipe.

When fabricating expedient electrodes, care must be taken to ensure that space is provided for oxygen flow to the electrode. In order to use the expedient electrodes with a torch designed for 5/16 in. diameter tubular electrodes, the emergency electrodes can be fitted with special adapters before they are taken down with the diver. The adapters also eliminate the need for a special torch designed for threaded electrodes, and they eliminate the awkward process of threading electrodes into a torch while underwater. An emergency electrode, cross-sectional area, and adapter are shown in Figure A1.

The electrode stub with the adapter attached is retained by the diver so that the adapter can be used again with new electrodes. The new electrodes must also be covered with masking tape, paper, or other effective insulating material to provide electrical insulation and waterproof the electrode.

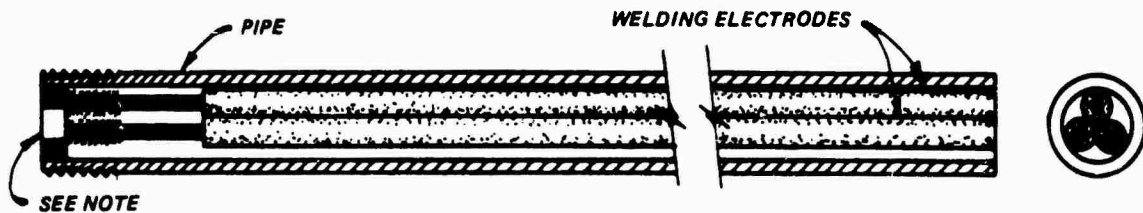

NOTE: GRIP ENDS OF COVERED ELECTRODES ARE BRAZED, WELDED, OR SOLDERED TO PIPE LEAVING SPACES FOR OXYGEN FLOW.

a. ELECTRODE

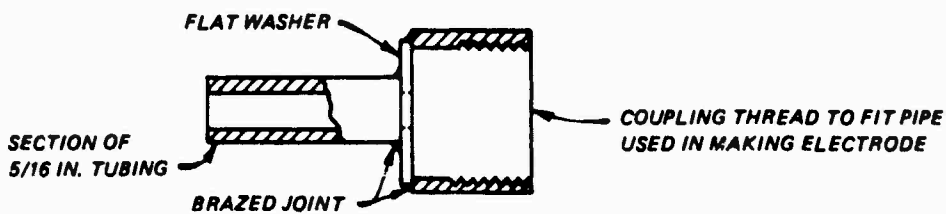

b. ADAPTER FOR USE WITH TORCH DESIGNED FOR 5/16-IN. ELECTRODES

Figure A1. Electrode improvised from pipe and welding electrodes, and adapter fittings