

AD-A178 182

SCALING OF THREE MICROMAUVE EXPOSURE SYSTEMS ON THE
BASIS OF AVERAGED WHOL. (U) ILLISA UNIV OR DEPT OF
PSYCHOLOGY H E O'CONNOR 86 FEB 87 N00014-83-K-0431

1/1

UNCLASSIFIED

F/G 6/18

NL

END
DATE
FILMED
4-87

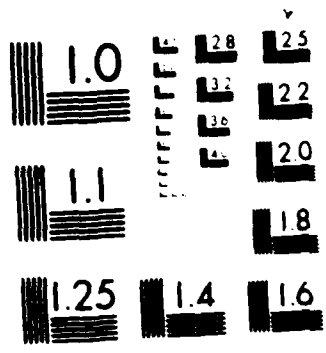

MICRO COPY RESOLUTION TEST CHART
SA-NA-1000-100-1000-1000

AD-A178 182 REPORT DOCUMENTATION PAGE

(U)		1b RESTRICTIVE MARKINGS NA	
2a SECURITY CLASSIFICATION AUTHORITY NA		3 DISTRIBUTION/AVAILABILITY OF REPORT Distribution Unlimited	
2b DECLASSIFICATION/DOWNGRADING SCHEDULE NA			
4 PERFORMING ORGANIZATION REPORT NUMBER(S)		5 MONITORING ORGANIZATION REPORT NUMBER(S) NA	
6a NAME OF PERFORMING ORGANIZATION University of Tulsa	6b OFFICE SYMBOL (if applicable)	7a NAME OF MONITORING ORGANIZATION Office of Naval Research	
6c ADDRESS (City, State, and ZIP Code) Psychology Dept. 600 S. College Tulsa, Oklahoma 74104		7b ADDRESS (City, State, and ZIP Code) 800 North Quincy Street Arlington, VA 22217-5000	
8a NAME OF FUNDING/SPONSORING ORGANIZATION Office of Naval Research	8b OFFICE SYMBOL (if applicable) ONR	9 PROCUREMENT INSTRUMENT IDENTIFICATION NUMBER N00014-83-K-0431	
8c ADDRESS (City, State, and ZIP Code) 800 North Quincy Arlington, VA 22217-5000		10 SOURCE OF FUNDING NUMBERS	
		PROGRAM ELEMENT NO	PROJECT NO
		TASK NO	WORK UNIT ACCESSION NO
11 TITLE (Include Security Classification) Scaling of Three Microwave Exposure Systems on the Basis of Whole-Body Averaged Specific Absorption Rate			
12 PERSONAL AUTHOR(S) M.E. O'Connor			
13a TYPE OF REPORT Final	13b TIME COVERED FROM Jun 1 83 TO Jun 1 83	14 DATE OF REPORT (Year, Month, Day) February 6, 1987	15 PAGE COUNT 38
16 SUPPLEMENTARY NOTATION			
17 COSATI CODES		18 SUBJECT TERMS (Continue on reverse if necessary and identify by block number)	
FIELD	GROUP	SUB-GROUP	
		Psychology Dept. (Psychology Dept.)	
		Psychology Dept. (Psychology Dept.)	
19 ABSTRACT (Continue on reverse if necessary and identify by block number)			
<p>Three systems for exposing small laboratory animals to 2450-MHz microwave radiation were compared using whole-body averaged specific absorption rate (SAR). The three systems were a plane wave propagated in an anechoic chamber, a circularly polarized waveguide, and a multimode cavity. Following calibration of the three systems, a temperature profile study assessing brain and colonic temperature in rat carcasses was performed. A third study investigated seizures in young mouse pups. There were statistically significant differences between the three systems regarding heat distribution as indicated by brain and colonic temperatures. Exposure in the circularly polarized waveguide resulted in lower temperatures at both sites. However, when young mouse pups were placed in the chambers and exposed at levels calculated to produce whole-body averaged SARs of 90 W/kg, the seizures produced by the plane wave exposures required nearly twice the amount of time as those in the waveguide or multimode cavity. The results suggest that average whole-body SAR should not be used for making comparisons of effects obtained in different exposure systems.</p>			
20 DISTRIBUTION/AVAILABILITY OF ABSTRACT <input checked="" type="checkbox"/> UNCLASSIFIED/UNLIMITED <input type="checkbox"/> SAME AS RPT <input type="checkbox"/> DTIC USERS		21 ABSTRACT SECURITY CLASSIFICATION U	
22a NAME OF RESPONSIBLE INDIVIDUAL T. C. BOZZELL		22b TELEPHONE (Include Area Code) 702/696-4053	22c OFFICE SYMBOL ONR

SELECTED
MAR 5 1987
A

DTIC FILE COPY

SCALING OF THREE MICROWAVE EXPOSURE SYSTEMS ON THE BASIS OF AVERAGED
WHOLE-BODY SPECIFIC ABSORPTION RATE

Mary Ellen O'Connor
Department of Psychology
The University of Tulsa
600 South College Avenue
Tulsa, Oklahoma 74104

ONR Contract Number N00014-83-K-0431

DTIC	
Announced <input type="checkbox"/>	
Justification <input type="checkbox"/>	
By _____	
Distribution/ _____	
Availability Codes	
Dist	Avail and/or Special
11	



This document has been approved
for public release and sale; its
distribution is unlimited.

87 2 18 067

TABLE OF CONTENTS

1.0 Introduction and Objectives.....4

2.0 Calorimetry.....6

 2.1 Methods and Procedures.....6

 Apparatus.....6

 Exposure Materials.....11

 Procedures.....11

 2.2 Results.....15

3.0 Temperature Profile Study.....15

 3.1 Methods and Procedures.....15

 Apparatus.....15

 Subjects.....15

 Procedures.....15

 3.2 Results.....17

4.0 Seizure Study.....19

 4.1 Methods and Procedures.....19

 Apparatus.....19

 Subjects.....19

 Procedures.....19

 4.2 Results.....20

5.0 Discussion and Conclusions.....20

6.0 References.....25

7.0 Acknowledgements.....25

8.0 Tables.....26

9.0 Figures.....29

LIST OF FIGURES AND TABLES

TABLES

TABLE I: Average pre-exposure and post-exposure brain and colonic temperature (mean and standard error).....26

TABLE II: Adjusted means for post-exposure brain and colonic temperature.....27

TABLE III: Average temperature change in the brain or colon (post-exposure minus pre-exposure, with standard errors).....28

FIGURES

FIGURE 1: Cross-section front view of anechoic exposure chamber.....29

FIGURE 2: Front Section view of sham chamber.....30

FIGURE 3: Environmental control system.....31

FIGURE 4: 2450 MHz exposure waveguide.....32

FIGURE 5: Microwave distribution schematic.....33

FIGURE 6: Multimodal cavity.....34

FIGURE 7: Diagram of twin-well calorimetry system.....35

FIGURE 8: Pre-exposure and post-exposure brain temperatures for rat carcasses exposed at 2450 MHz in an anechoic chamber, a multimodal cavity or a circularly polarized waveguide at an average whole body SAR of 10 W/kg for 15 minutes.....36

FIGURE 9: Pre-exposure and post-exposure colonic temperatures for rat carcasses exposed at 2450 MHz in an anechoic chamber, a multimodal cavity or a circularly polarized waveguide at an average whole body SAR of 10 W/kg for 15 minutes.....37

FIGURE 10: Latency to seizure in seconds for CF-1 mice exposed at 2450 MHz in an anechoic chamber, a circularly polarized waveguide, or a multimode cavity.....38

SCALING OF THREE MICROWAVE EXPOSURE SYSTEMS ON THE BASIS OF AVERAGED
WHOLE-BODY SPECIFIC ABSORPTION RATE

1. INTRODUCTION AND OBJECTIVES

This investigation compared three microwave exposure systems on the basis of the average whole-body specific absorption rate (SAR). The investigation concentrated on procedures typically reported for the assessment of whole-body averaged SAR. The investigation was conducted to determine the reliability and validity of the measurement of whole-body averaged SAR according to standard laboratory procedures. The investigation was not designed to attempt to improve these standard laboratory procedures. The comparison was based on a specific effect in a biological preparation in each of the three microwave exposure systems.

An understanding of the widely-used construct of the whole-body averaged SAR, including its limitations, is critical to the interpretation of much of the existing research on the biological effects of microwave radiation exposure. The recommendations for exposure to radiofrequency (RF) radiation, both occupational and general population, suggested by the American National Standards Institute Committee 95 (ANSI C95.1-1982) and the National Council on Radiation Protection and Measurements (NCRP #86, 1986) rely on the concept of the whole-body averaged SAR. These committees compared a large number of studies that used different types of RF exposure systems, different methods, and different species for subjects. The studies these committees examined also varied with respect to the information regarding exposure conditions. These committees based their

recommendations on the whole-body averaged SAR either as reported by the authors or as estimated from other reported parameters. The rationale statement accompanying the ANSI C95.1 recommendation states that the committee did not base their deliberations and resulting recommendation on any effects reported from studies in which an SAR was not reported or could not be calculated or estimated.

The present investigation provides a direct appraisal of whether SA and SAR, as typically measured, are reliable predictors upon which scaling from one microwave exposure system to another can proceed. The three systems compared were a plane wave CW field propagated in an anechoic chamber (Strattan and O'Connor, 1982) a multimode cavity (Heynick, et al., 1977) and a circularly polarized waveguide system (Guy and Chou, 1975). The objective was to determine if equating the exposure conditions in the three systems on the basis of averaged whole-body SAR as determined by twin-well calorimetry methods would result in similar thresholds for observing biological effects.

The biological endpoints employed were temperature increments in different locations in rat carcasses, and latency to seizure in young mouse pups. Since the focus of the investigation was on the measurement of average whole-body SAR in different exposure systems, the biological effects to be observed were selected on the basis of simplicity and efficiency of measurement. The biological endpoints used in the investigation had been reported from more than one laboratory and the methodology required to measure the endpoint seemed reasonably simple to replicate.

2. CALORIMETRY

2.1 Methods and Procedures

2.1a Apparatus:

Three exposure systems were studied. The plane wave CW microwave exposure facility provided a uniform intensity plane wave field at 2450 MHz inside a 3.0 x 3.0 x 2.4 meter electromagnetically shielded anechoic chamber. The chamber was a Lindgren 4-shield radiofrequency shielded room. The interior of the chamber was lined with Emerson and Cuming absorber material. The walls and floor of the perimeter area were lined with CVCB-9 absorber material while the ceiling and door were covered with AN-77 absorber. The central floor area in the direct illumination region was covered with high performance VHP-26 pyramidal absorber.

Continuous wave (CW) 2450-MHz microwave power was generated by a Cober magnetron generator with special filtering on the power supply. A pyramidal horn antenna (modified Narda 644) mounted in the ceiling of the anechoic chamber illuminated a 1.0 square meter floor area with plane wave radiation of uniform intensity. A Narda 8601 Radiation Monitor with an 8621 omnidirection probe were used to measure field uniformity. Power densities with maximum variation of 1.0 db were produced at the top of the high performance pyramidal absorber in the central floor area. The Cober S1/V-F microwave power source provided CW power at levels from 100 to slightly over 1000 watts. The power ripple was less than 50 watts peak to peak. The microwave output was coupled to the chamber through a directional coupler and WR-285 waveguide. A Narda 7000A microwave multimeter was used as a power meter to monitor and set the output power and as a reflectometer to measure and tune antenna mismatch. A Racal-Dana 9921 microwave counter was used to

verify the operating frequency. The waveguide ran to the antenna and a Wavetek 2002 signal generator and the microwave multimeter were used to adjust the slide-screw tuner at the antenna feed point. A schematic representation of the chamber is presented in Figure 1.

The sham chamber was located adjacent to the microwave exposure facility and is depicted in Figure 2. The chamber was constructed of 1/2 inch plywood with inside dimensions of 1.27 x 1.40 x 0.91 meters. Entry ports were placed on top of the chamber for air supply and return air plenums were connected to the air conditioning and humidity control system that was shared with the anechoic chamber. The floor of the sham chamber consisted of a caster mounted platform that slid out of the front of the enclosure to permit easy placement of the exposure materials. The inside of the chamber was lined with styrofoam that had been painted black to resemble the inside of the microwave exposure chamber. The CVCB-9 absorber material lining the walls and floor of the anechoic chamber were black. A lightbulb located on the ceiling of the chamber provided illumination matching the illumination level inside the anechoic chamber.

A schematic representation of the temperature and humidity control system is depicted in Figure 3. This system was fabricated by The University of Tulsa. In addition to a Vista Scientific Environ-Aire E-1000 unit, the air conditioning system used a residential window type air conditioning-heat pump unit to control temperature and circulate the air. Residential type humidifiers and dehumidifiers and an electronic air filter/cleaner were mounted in the air plenums. Thermostats and humidistats automatically controlled the air circulated to the anechoic and sham chambers. The temperature at the location of the exposure

material differed by no more than 1°C between the anechoic and sham chambers.

Two circularly polarized waveguides (Guy and Chou, 1977; Guy, et al., 1979) were obtained from The Bioelectromagnetics Research Laboratory at the University of Washington, Seattle, Washington. One chamber was used as a sham chamber while the other was powered by the Cober source. The microwave power at 2450 MHz was supplied to the circularly polarized cylindrical waveguide cell through a waveguide and coaxial cable transmission system from the Cober S1/V-F magnetron source. After monitoring the source output power level with a Narda 7000 microwave multimeter through a 60 db directional coupler, approximately 10% of the power was diverted to the circular waveguide cell. The remaining 90% went to the anechoic chamber through the existing waveguide. A coaxial cable was used to transport the power to the circular waveguide cell located inside of the environmentally controlled sham chamber. Approximately 20 feet of cable added attenuation and reduced the maximum power available at the test cell to the desired range of 10 watts maximum CW 2450-MHz microwave power. A tuner eliminated reflections at the input port, and the other three ports were terminated with matched loads. Figure 4 depicts the waveguide and Figure 5 provides a schematic of the distribution of microwave energy by the Cober power source to the anechoic chamber and the waveguide cell.

Two multimode cavities were obtained from the Neurobehavioral and Radiobiology Research Laboratory at the Veterans Administration Medical Center in Kansas City, Missouri. These cavities were originally designed for exposure of primates as described by Heynick, et al.,

(1977). The multimode microwave cavity was cubical and measured 90 cm internally. The cavity was powered by a Type 2M53 magnetron. Radiofrequency energy was fed into one of the corners of the chamber through an adjustable iris for impedance matching. The iris was at the mouth of a section of waveguide whose central longitudinal axis was collinear with the body diagonal of the cube. A mode stirrer was mounted near the center of one of the side walls of the cavity. Radiopaque windows on the top and front of the cavity provided ventilation and made viewing the inside of the cavity possible. These windows were aluminum grilles, about 2.5 cm square and 3.8 cm deep which yielded about 37 db of attenuation at 2450 MHz. The forward and reflected power was measured with calibrated diode detectors in a bidirectional coupler between the magnetron and the cavity. Power values were varied by 60 Hz pulse width modulation and were held constant by detector-output feedback to a thyristor control circuit in the magnetron power supply. The microwave source for the multimode chamber produced a pulsed waveform, while the Cober source used with the anechoic chamber and waveguide cell produced a true CW or constant power waveform. The multimode pulsed waveform consisted of pulses of about one millisecond duration repeating at 60 pulses per second. The average power level was determined by multiplying the peak pulse value by the duty cycle which varies from about 1% to 10%. The average power and not the peak power was used to determine the SAR. The two units were placed side by side and one was used as the sham chamber. The exposure materials were situated at different locations in the chambers by placement on styrofoam blocks at different heights from the floor of the chamber. The multimode chamber had no dedicated environmental control

system and was dependent on the ambient room temperature and humidity. A schematic view of the multimode chamber is presented in Figure 6.

The twin well calorimeter was fabricated at the University of Utah and is depicted schematically in Figure 7. The calorimetry system consisted of two twin-well calorimetry units, one two pen chart recorder (Houston Instruments, #D-5216-5), one immersion circulator (Fischer #73), one 17 lb capacity Corning Pyrex container (Fischer #11-823J) and one 140 BTU/hr refrigeration system and insulated enclosure. Each twin-well calorimeter consisted of two 25 x 10 cm aluminum cylinders surrounded by thermocouples attached to the outer wall and connected in series so that the individual voltages were additive. The thermocouples of the right cylinder were connected to the thermocouples of the left cylinder so that the voltages were subtractive. Any temperature difference between the cylinders resulted in a net voltage output from the thermocouple arrays. The voltage output from each twin-well calorimeter was then fed to one channel of the two pen chart recorder. The twin wells were surrounded by an oval cylinder designed to hold the temperature constant by circulating water through a series of coils. The unit was placed in a 13.5 x 17.5 cm container. The immersion circulator consisted of a continuously-variable heater coil with an output range of 100 to 1000 watts controlled by an immersed contact thermometer, a 15 liter per minute pump, and a thermometer to check the bath temperature. A refrigeration unit was constructed to enclose the Pyrex water bath container and maintain the bath temperature between 12 and 14°C, which was below room ambient temperature.

2.1b Exposure Materials:

Initial measurements were made with plastic bags containing different masses of mammalian Ringer's solution. The bags were placed at different locations in the chambers and temperature rise was used to calculate SARs.

The animals used for twin-well calorimetry were Long-Evans rats chosen from the animal colony at The University of Tulsa. The animals were born in the colony from stock originally obtained from Charles Rivers Breeding Laboratory. The animal colony was maintained in a room with ambient temperature at 21°C and relative humidity of 60-75%. A 12/12 hour light/dark cycle was maintained automatically. The animals were caged in wire hanging cages with laboratory rodent chow and tap water available ad libitum while they were in the colony.

2.1c Procedures:

The locations in the chambers and the power settings within each chamber that resulted in similar SARs were determined from measurements of temperature change of the Ringer's solution in the plastic bags. Animal carcasses were then used to determine if the selected locations and power settings did in fact produce the same SAR measurements.

The SARs of phantom loads of Ringer's solution in plastic bags were measured for a range of masses, power levels and positions in each of the three exposure systems. The SARs were calculated from the difference in pre- and post-exposure temperatures measured by a Bailey BAT-8 thermocouple probe. The exposure time was always less than 15 minutes. This value was determined by analysis and measurement to be small relative to the thermal time constant and produced an accurate

value for initial rate of temperature increase due to absorbed microwave power. The SAR was then calculated as

$$\text{SAR} = C_p \quad T/t$$

(specified as W/kg)

where C_p is the specific heat capacity of the phantom Ringer's solution (J/kg - $^{\circ}$ C)

T is the post- and pre-exposure temperature difference

t is the exposure time (sec)

Phantom masses ranged from 0.05 to 0.3 kg. Over 150 measurements were performed with an approximately uniform distribution over mass and exposure system. The locations in the anechoic chamber were varied over both the height (separation from the horn antenna) and displacement in the lateral plane over values considered as useable for field uniform illumination regions.

There was no location variable for the waveguide cell. The variation of SAR with location in the multimode chamber was determined by measured SARs over a three dimensional grid of cells of about 0.18 meter cubes using a 0.25 kg phantom. The maximum SAR was about twice the minimum SAR over the range of cells, with a standard equal to 19% of the average SAR. Subsequent experiments were all performed in a cell of about average characteristics. A nonlinear conversion relationship was developed to relate power level meter settings on the multimode chamber to actual power levels.

The data generated by these measurements over phantom mass, location, power level and exposure system were used to estimate initial conditions for subsequent carcass and seizure tests. The data were also analyzed as a part of a M.S. thesis in electrical engineering (Rowe and

Strattan, 1987). This analysis resulted in a SAR prediction equation.

This equation is expressed by the formula:

$$\text{SAR} = G_i \text{ PW/M}$$

where PW is the input microwave power level

M is the mass of phantom

G_i is a factor for the i_{th} exposure system.

The exposure system dependent factor G_i is the product of three factors,

$$G_i = S_{i1} S_{i2} S_{i3}.$$

S_{i1} describes the ratio of power density at the phantom location to the effective radiated power. S_{i2} is a coupling gain, such as the horn antenna gain in the case of the plane wave anechoic chamber system. S_{i3} is an effective absorption area and depends upon phantom size. For the equation developed

$$S_{i3} = A_0 (M/M_0)^{J_i}$$

where $A_0 = 0.01357 \text{ m}^2$ and $M_0 = 0.15 \text{ kg}$ are the surface area and mass of a reference normalized phantom

M is the phantom mass

J_i is an experimentally determined exponent parameter that yields the best statistical fit to the data base for the i_{th} exposure system

The values calculated by this formula result in SAR predictions that agree with the experimental data to within 10% for Ringer's solution phantoms over the range of masses from 0.05 to 0.3 kg across the three exposure systems. For an example of the use of this procedure see Rowe and Strattan (1987).

Following the establishment of the Ringer's solution measurements, twin-well calorimetry procedures for the determination of SAR in rat carcasses were employed. At 10:00 h two animals of equal mass were sacrificed using CO₂ and placed in plastic bags that were then heat sealed and placed in the twin-well calorimeter. The time and the water bath temperature were recorded and the carcasses remained in the calorimeter for a minimum of seven hours to reach stabilization. The necessary power level to achieve the desired SAR was determined using Ringer's solution of equal mass. The type of chamber, the position and orientation of the exposure material within the chamber, duration of exposure, ambient temperature and humidity outside and inside the chamber, and microwave power level were recorded. The two carcasses were removed from the wells and placed in the chambers. One was placed in the exposure chamber and one in the sham chamber. Following exposure the animals were removed from the chambers and placed in the wells of the calorimeter where they remained until the following morning. Each chart recording was scored by two independent observers and the measurement was converted to SAR with the aid of an IBM PC. Hard copy of the raw data was maintained with the chart recording and data sheets for the exposure.

The calorimetry for the seizure study was performed on young mouse pups in the same manner as described above with the following exceptions. The mouse pups were selected on the basis of equivalent body mass ($8 \text{ g} \pm 0.2 \text{ g}$). After the pups were sacrificed using CO₂, the carcasses were placed in styrofoam molds with the tails tucked underneath the body and the molds were then placed in a freezer where the carcasses were frozen.

2.2 Results

Obtaining similar averaged whole-body SARs in the three chambers proved to be more difficult than anticipated. Many duplicate measures were taken. The large number of duplicate measures were required because the precise location and orientation of the carcass within the chamber had to be exact in order for SARs to be replicable even within one system. The required precision in measurement was more extensive than anticipated in the research proposal. Following the relatively extensive calibration phase, an average whole-body SAR of 10 W/kg was obtainable in each of the three systems.

3.0 TEMPERATURE PROFILE COMPARISON

The second part of this investigation compared brain and colonic temperature in rat carcasses exposed for 15 minutes at an average whole-body SAR of 10 W/kg in the multimode cavity, anechoic chamber, or circularly polarized waveguide.

3.1 Methods and Procedures

3.1a Apparatus:

The three exposure systems described above (2.1a) were used in this part of the investigation. Brain implantations were performed with a standard stereotaxic instrument.

3.1b Exposure Materials:

The subjects were Long-Evans rat carcasses obtained from the animal colony described above (2.1b). The subjects were females weighing between 230 and 240 g.

3.1c Procedures:

Female rats were weighed, sacrificed using CO₂, placed in the stereotaxic, and implanted with a capillary tube inserted 6mm down from

bregma. It was empirically determined that 33 minutes were required to remove a female from the colony, perform the surgery and transport the carcass to the multimode cavity location. For this reason the carcasses were kept in holding cages for 33 minutes before being positioned in any of the appropriate microwave exposure systems. After being placed on the exposure platform, a Luxtron temperature probe was placed in the implanted tube and the colonic temperature was taken with a Bailey BAT-8 thermometer and probe. The brain and colonic temperature was recorded 30 seconds prior to exposure. During the 15 minute exposure, readings from the Luxtron probe were recorded every 15 seconds. Following exposure the colonic temperature and the final brain temperature were recorded. Two sham and two exposed rats were measured in each of the three chambers. The sham animals were not run simultaneously because there was only one Luxtron thermometer available. The sham controls for the rats exposed in the anechoic chamber were measured on different days while the sham carcasses for the circularly polarized waveguide and the multimode cavity were measured immediately before or after the microwave exposed carcass. The sham controls for the anechoic chamber could not be measured on the same day because the microwave exposure resulted in an ambient temperature increase in the anechoic chamber due to heating of the absorber material. If sham exposures and microwave exposures were conducted on the same day, the absorber material would have continued to heat and the ambient temperature would not remain constant. The sham exposures in the anechoic chamber were performed with the microwave radiation on, but with the sham carcass shielded from the radiation. The radiation was on during the sham exposures so that

the increase in ambient temperature experienced by the non-shielded, microwave-exposed carcasses was also experienced by the sham carcasses.

3.2 Results

Figure 8 presents pre-exposure and post-exposure brain temperatures and Figure 9 presents pre-exposure and post-exposure colonic temperatures for the rat carcasses in all three systems. The ambient temperature in the anechoic chamber and the circular waveguide were controlled by the shared air conditioning and humidity system. The ambient temperature for the multimode cavity system was dependent upon room temperature. Since the pre-exposure ambient chamber temperature was significantly different across the three systems, the analyses for all of the temperature profile data were based on analysis of covariance with initial chamber temperature as the covariate. Planned comparisons were made using the formula recommended for contrasts for analysis of covariance according to Pedhauzer (1982). These procedures attempt to adjust for the effect of a correlation between the covariate and the dependent variable. Outliers that were more than 2 standard deviations from the mean were also removed before the analyses were performed. The outlier requirement resulted in the removal from statistical analyses of one post-exposure brain temperature measurement in the circularly polarized waveguide cell.

There were no statistically significant differences in pre-exposure brain temperature ($F = 1.40, p = 0.30$) or colonic temperature ($F = 0.20, p = 0.80$) across the three systems. However, both brain temperature ($F = 4.13, p = 0.06$) and colonic temperature ($F = 7.45, p = 0.015$) differed across the three systems following the exposure. Table I provides the means for both the pre- and post-exposure temperatures

and Table II includes the means as adjusted for the covariate analysis. Exposure in the multimode chamber produced the highest brain and colonic temperature. However, when these temperatures were adjusted for chamber temperature the contrasts following the multiple regression and covariation procedures described above indicated that post-exposure brain and colonic temperatures differed between the anechoic chamber and the waveguide but the multimode cavity was not different from either. Temperature difference (post-exposure temperature minus pre-exposure temperature) is presented in Table III. The temperature differences in the brain and the colon were analysed within each system of exposure. The temperature change in the brain was not significantly different from that in the colon for animals in the anechoic chamber ($t = 1.28$, $p = 0.29$). However the temperature elevation in the two locations was significantly different in the multimode cavity with the colonic temperature rising more than the brain temperature ($t = 4.06$, $p = 0.03$). Not only were the brain and colonic temperatures in the circularly polarized waveguide different significantly ($t = 5.04$, $p = 0.015$), but the colonic temperature actually decreased between the pre-exposure and the post-exposure measurement. Under these exposure conditions, the temperature profile in the circularly polarized waveguide was considerably different from that in the anechoic plane wave chamber or the multimode cavity. The differences between the waveguide and the multimode cavity did not reach statistical significance. Some of the difficulties in interpreting the results of the raw data and the adjusted analysis will be treated in the discussion section of this report.

4.0 SEIZURE STUDY

In the third part of this investigation latency to seizures were observed in young mouse pups exposed at an average whole-body SAR of 95 W/kg in the anechoic chamber, the circularly polarized waveguide, or the multimode cavity.

4.1 Methods and Procedures:

4.1a Apparatus:

The three exposure systems discussed above (2.1) were used in this study. During exposures the pups were placed in a 250 ml glass beaker. The beakers could be observed from outside the chamber for the multimode cavity and the circularly polarized waveguide. A closed circuit television monitor was used to observe the seizures in the anechoic chamber. In this phase of the investigation, the multimode cavity exposures were performed first and the ambient temperature that existed for those exposures was matched in the anechoic chamber and the waveguide.

4.1b Subjects:

The subjects were 14 day old CF-1 mouse pups born and raised in the animal colony described above (2.1b). The pups were derived from stock originally obtained from Charles Rivers Laboratories.

4.1c Procedures:

A 14 day old pup was chosen from the colony and the sex and mass was recorded. The pup was taken to the appropriate microwave exposure facility and placed in a 250 ml glass beaker. The beaker was placed in the pre-determined appropriate spot in the chamber. The previous calorimetry had established the appropriate settings for the power. The

actual averages for the calorimetry runs did not differ significantly ($F = 0.43$, $p = 0.66$) and resulted in average whole body SARs of 101 (circularly polarized waveguide), 93 (anechoic chamber) and 92 (multimode chamber) W/kg. The power was turned on and the pup was observed until a seizure began. Latency to seizure was recorded as was the survival of the pup. Survival was actually noted for several days following the exposure.

4.2 Results:

Figure 10 presents latency to seizure for pups in all three systems. The mass of the pups ($F = 2.23$, $p = 0.15$) and the ambient temperature in the chamber prior to the exposure ($F = 0.79$, $p = 0.48$) did not differ significantly, but the chamber humidity did differ ($F = 5.44$, $p = 0.03$). The multimode cavity was lower ($X = 18.4$) than both the anechoic chamber ($X = 19.9$) and the waveguide ($X = 20.3$) which did not differ from one another. The latency to seizure was significantly different in the three systems ($F = 22.7$, $p = 0.0001$). The seizures in the anechoic chamber required nearly twice the amount of time ($X = 413.6$) as those in the waveguide ($X = 208.8$) or the multimode cavity ($X = 188.8$).

5.0 DISCUSSION AND CONCLUSIONS

The results of the three studies indicated that the typical laboratory techniques used for the measurement of average whole-body SAR do not result in similar biological outcomes in different exposure systems. The standard procedures appear to lack the reliability that would warrant unquestioned acceptance of reported whole-body averaged SARs as the base measurement for comparison of data from differing exposure systems. Many previous studies have documented the importance

of a variety of factors in dosimetry (Gandhi, 1980). Such factors as orientation of the preparation in the field, location of the preparation in the field, as well as room temperature and humidity have all been identified as important parameters in dosimetry. Prior to the definition of the SAR no dosimetry was possible in the area of radiofrequency radiation measurement. Measures of power density were available as were measures of temperature. Reliance on these measures and the verification of the concept of SAR with temperature measurements has led to some confusion with regard to the concept of SAR as a temperature dependent, rather than a temperature related construct. The present investigation does not support the idea that the results of studies having considerable differences in exposure conditions can be compared if a measurement of the averaged whole-body SAR is reported in the procedures of the studies.

The first part of the present investigation consisted of determination of exposure conditions that would result in equivalent SAR values in the three exposure systems. Following the measurements with the Ringer's solution, 19 exposures were required to establish reliable locations and power settings for a 10 W/kg SAR measurement in the Long-Evans rat carcasses. The high variability was not related to fluctuations in power as indicated by the dedicated instrumentation. The calorimetry measurements for the mice produced even more variability and 41 measurements were needed to find comparable SAR values for the small mouse pups.

The three systems of exposure each present unique concerns for SAR measurement. It is important to note, again, that this investigation did not attempt to improve upon the measurement of whole-body averaged

SAR. Rather, in this investigation SAR was measured in a manner typical of the manner in which it is measured in the laboratories contributing to the data base on biological effects of radiofrequency radiation. The measurement of whole-body averaged SAR could be improved upon and more precise techniques have been reported in dosimetry studies. Single SARs and SAs could be measured at different points in the preparation. The investigation was not intended to question the construct of SAR. However, in recognizing that most laboratories report measurements of average whole-body SAR, these results do suggest that the interpretation of comparisons of data from different exposure situations should be made cautiously. Perhaps, more cautiously than has been the case in the past.

The temperature profile study indicated that the temperature distribution in the circularly polarized waveguide is quite different from the temperature profile obtained in the anechoic chamber or the multimode cavity. The systems were compared on the basis of average whole-body SAR. The difference may be due to the fact that the incident angle of the radiation in the three systems is different. The animal preparation in the anechoic chamber receives dorsal exposure, the waveguide exposure is usually anterior or cranial, and the multimode exposure should be more uniform. The fact that the head is the first part of the body and the tail is the last part of the body to receive radiation could account for the low colonic temperature difference in the circularly polarized waveguide. However, the temperature change in the brain was highest in the carcasses exposed in the anechoic chamber, not the waveguide. It is important to note here that the waveguide and the anechoic chamber shared a common ambient temperature and humidity

source. The difference may be accounted for by the fact that the resonance of the exposed material is slightly different in the waveguide as compared to the anechoic chamber or the multimode cavity.

The results from the third study are difficult to compare to the second study. In the temperature profile study the brain temperature as well as the temperature increment in the brain was highest in the anechoic chamber. However, the animals in the seizure study required twice as much time before a seizure was induced if they were exposed in the anechoic chamber. As noted earlier, there are differences in the exposure parameters between the three exposure systems and there are differences between the studies as well. One of the main differences in the third study was that the exposed material consisted of live non-restrained animals. The orientation of the radiation and the movement of the animals in the beakers resulted in different exposure conditions in the three systems with regard to several previously identified important parameters.

The results of this study indicate that using whole-body averaged SAR as a measure of energy dose rate for comparing data collected under otherwise different exposure conditions is questionable. Additionally, the results suggest that measurement of average whole-body SAR in different types of radiofrequency exposure systems requires further study. Also, it would appear that most of the laboratory studies which have been cited with respect to decisions regarding exposure criteria to radiofrequency radiation have measured SAR in much the same manner as reported in this investigation. The typical measurement of whole-body-averaged SAR simply does not overcome the other differences in exposure parameters and does not provide a means for comparison across exposure

systems. This investigation did not attempt to improve upon the measurement of the average whole-body SAR. Indeed, one goal was to measure SAR in as typical a fashion as possible. The results do not support the use of the whole-body average SAR as a baseline comparison for data obtained in different exposure systems.

REFERENCES

- ANSI C95.1, 1982. Safety Levels With Respect to Human Exposure to Radiofrequency Fields, 300 kHz to 100 GHz. New York, American National Standards Institute.
- Gandhi, O 1980. State of the knowledge for electromagnetic absorbed dose in man and animals. Proceedings of the IEEE, 68:24-32.
- Guy, AW, and CK Chou, 1977. System for quantitative chronic exposure of a population of rodents to UHF fields. In C Johnson and M Shore (Eds.), Biological Effects of Electromagnetic Waves. Washington, D.C. U.S. Government Printing Office, HEW Publication FDA 77-8011, 389-410.
- Guy, AW, J Wallace, and JA McDougall, 1979. Circularly polarized 2450-MHz waveguide system for chronic exposure of small animals to microwaves. Radio Science, 14,(6S):63-74.
- NCRP, 1986. Biological effects and exposure criteria for radiofrequency electromagnetic fields. Bethesda, Maryland: National Council on Radiation Protection and Measurements, NCRP Report No. 86.
- Heynick, LN, P Polson, and A Karp, 1977. A microwave exposure system for primates. Radio Science 12(6S):103-110.
- Justesen, DR, DM Levinson, RL Clarke, and NW King, 1971. A microwave oven for behavioural and biological research: Electrical and structural modifications, calorimetric dosimetry, and functional evaluation. J of Microwave Power, 6(3):237-258.
- O'Connor, ME and RD Strattan, 1985. Teratogenic effects of microwave radiation, Washington DC, NTIS No. PB85-207 462/AS.
- Rowe, M and RD Strattan, 1987. A method of estimating specific absorption rates of three microwave exposure methods, Proceedings IEEE Region 5 Conference.
- Strattan, RD and ME O'Connor, 1982. A CW plane wave microwave exposure facility for long-term low-power density studies. BEMS Annual Meeting Abstracts, Gaithersburg, Maryland, Bioelectromagnetics Society.

ACKNOWLEDGEMENTS:

The research was conducted with the assistance of Drs. Robert Strattan, David Bartsch, James Sanza and Chris Hutchens, as well as Debra Tremble Limbocker, Thomas Peterson, Mark Rowe, Keow Seng Ng, and Brian Cooper.

TABLE I: AVERAGE PRE-EXPOSURE AND POST-EXPOSURE BRAIN AND COLONIC TEMPERATURE (MEAN AND STANDARD ERROR)

EXPOSURE SYSTEM	PRE-EXPOSURE		POST-EXPOSURE	
	Brain	Colonic	Brain	Colonic
Anechoic Chamber Plane Wave	27.43 (0.48)	31.7 (0.78)	29.93 (0.41)	33.43 (0.49)
Circularly Polarized Waveguide	26.05 (0.84)	31.5 (0.29)	27.7 (0.84)	31.23 (0.23)
Multimode Cavity	31.15 (0.18)	33.87 (0.19)	33.2 (0.35)	36.67 (0.41)

TABLE II: ADJUSTED MEANS FOR POST-EXPOSURE BRAIN AND COLONIC TEMPERATURE

EXPOSURE SYSTEM	COLONIC	BRAIN
Anechoic Chamber	34.86 a	31.35 b
Circularly Polarized Waveguide	32.65 a	29.91 b
Multimode Cavity	33.82	30.74

Means with the same subscripts are significantly different from one another.

TABLE III: AVERAGE TEMPERATURE CHANGE IN THE BRAIN OR COLON
 (POST-EXPOSURE MINUS PRE-EXPOSURE, WITH STANDARD ERRORS)

EXPOSURE SYSTEM	BRAIN	COLON
Anechoic Chamber	2.50 (0.12)	1.73 (0.56)
Circularly Polarized Waveguide	1.65 (0.64)	-0.28 (0.36)
Multimode Cavity	2.05 (0.33)	2.80 (0.32)

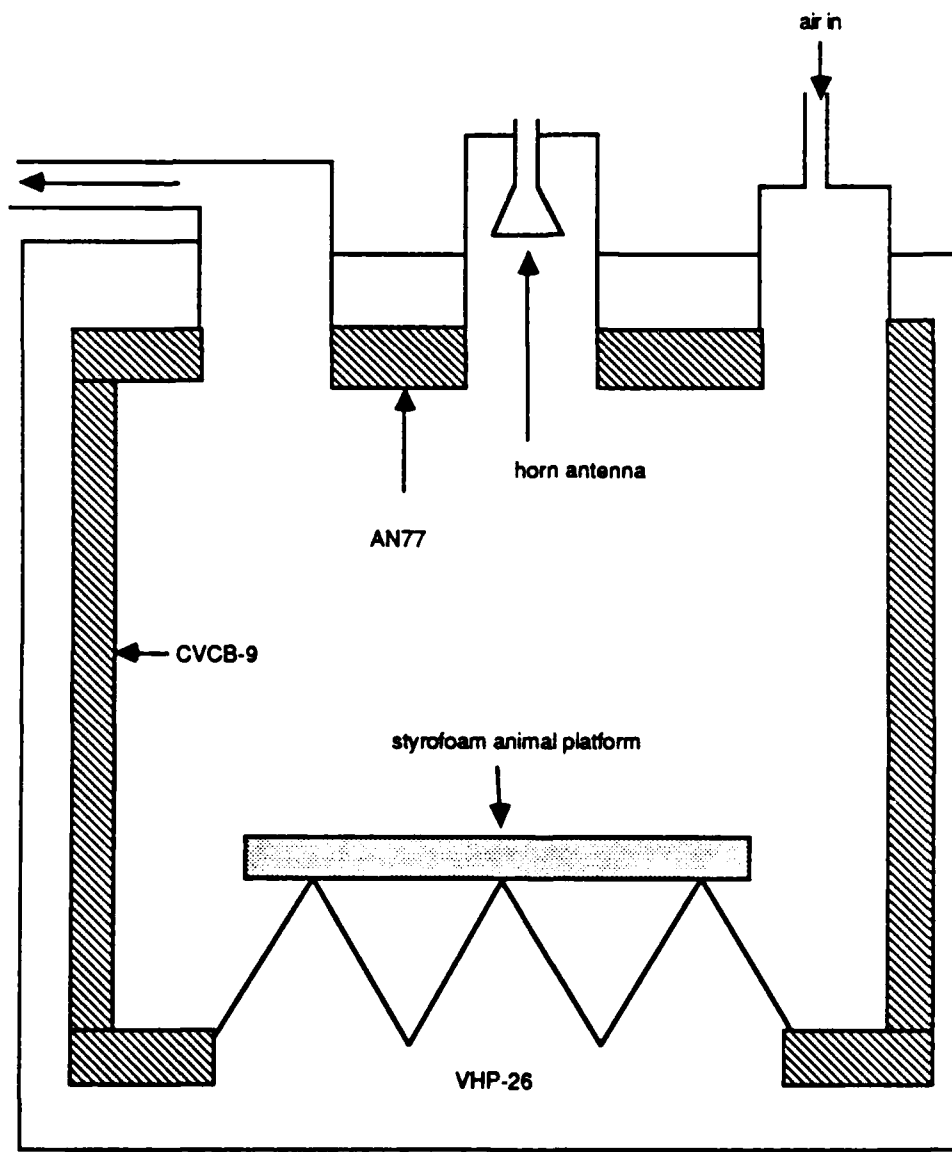

Figure 1 Cross-section Front View of Anechoic Exposure Chamber

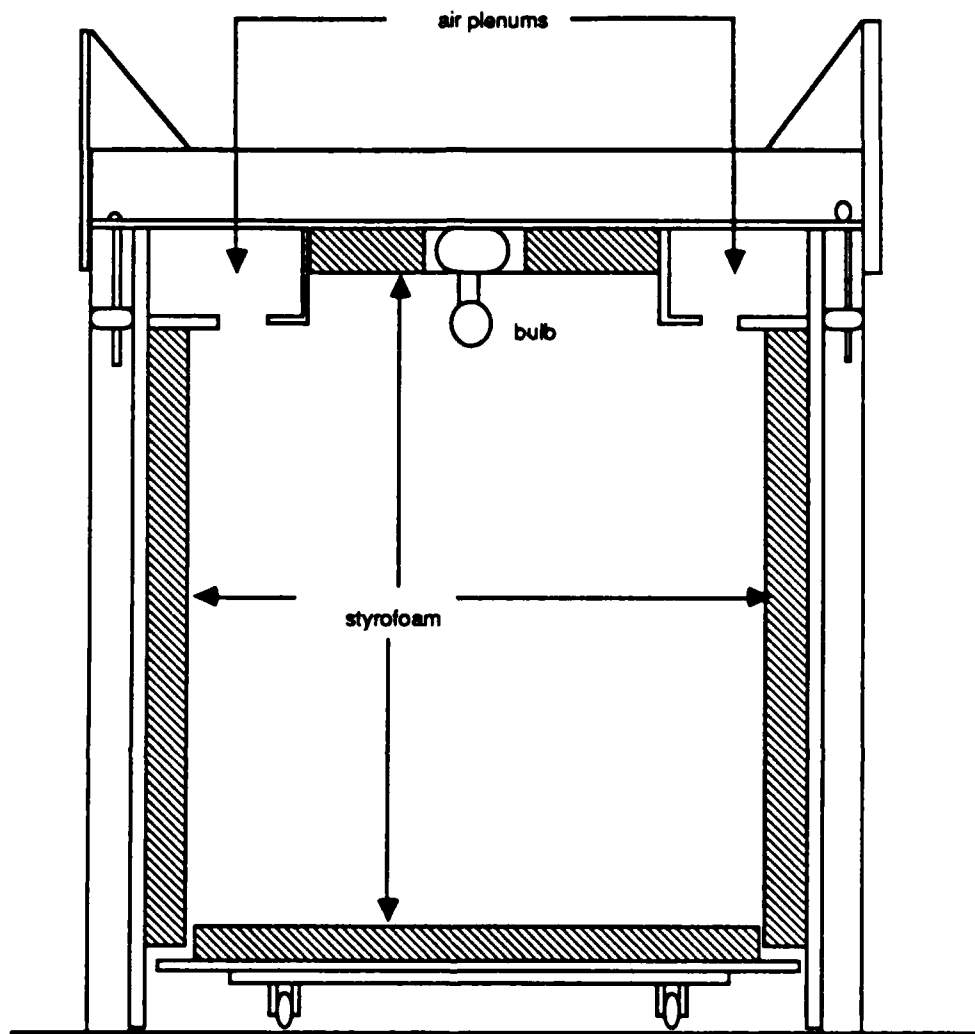

Figure 2 Front Section View of Snam Chamber

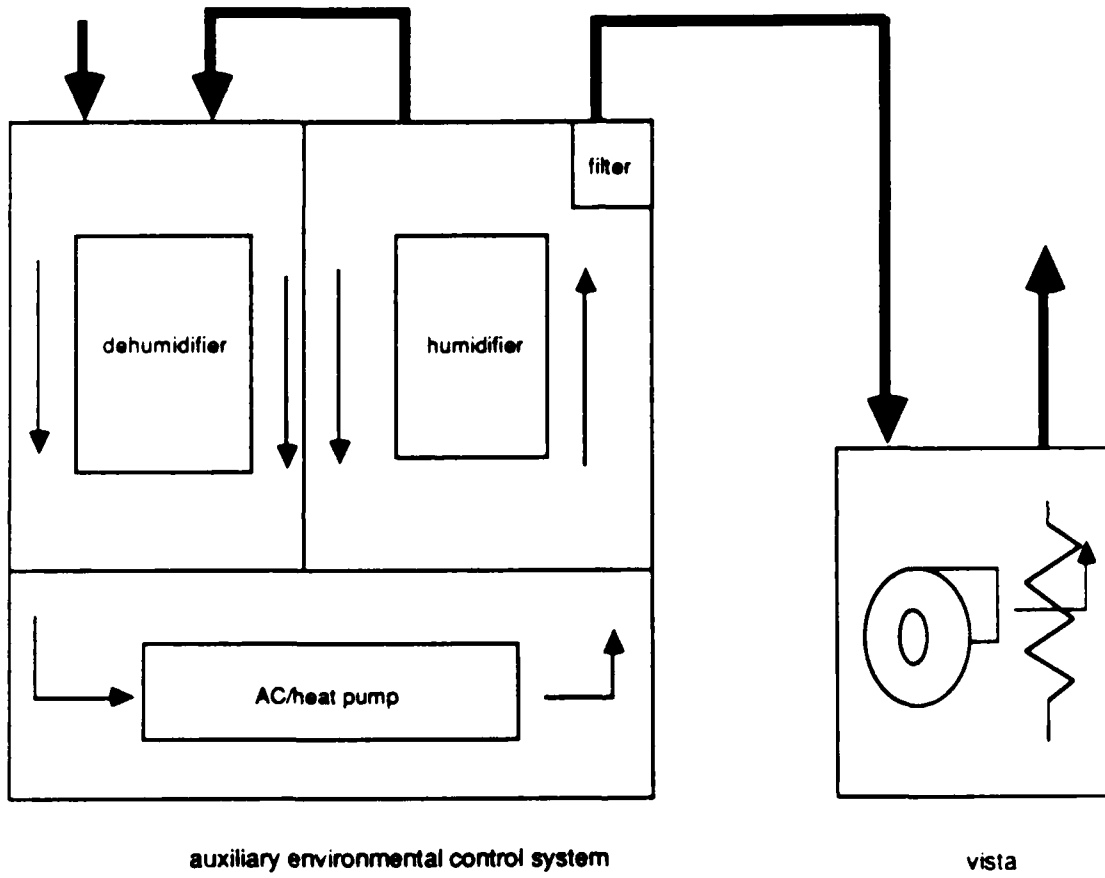

Figure3 Environmental Control System

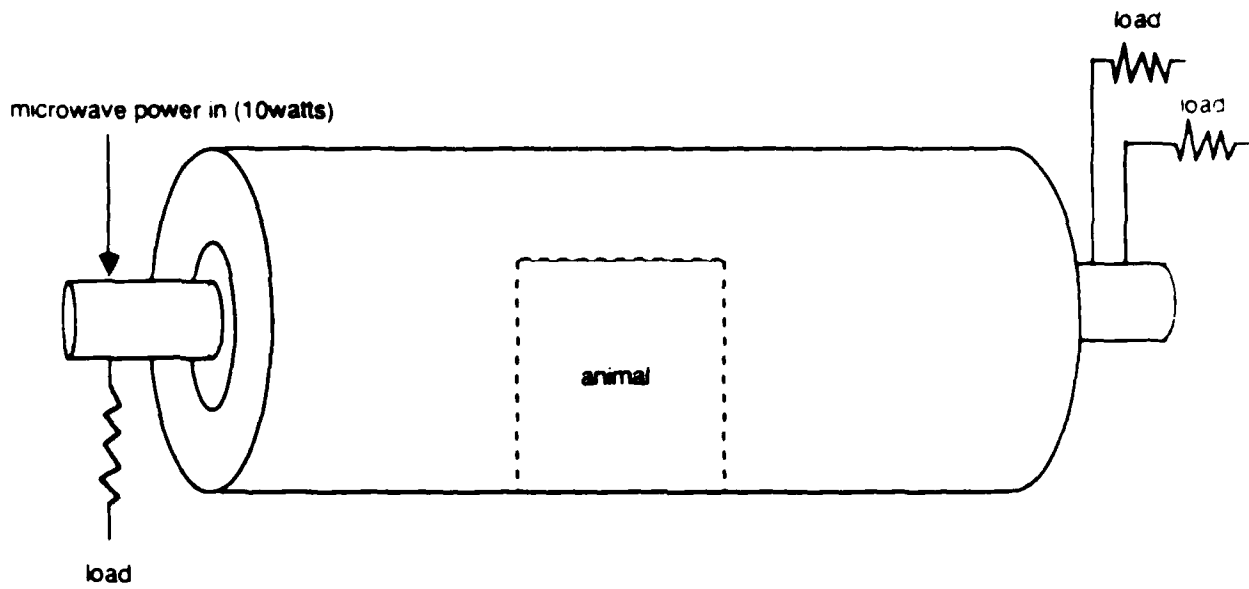

Figure 4 2450-Mhz Exposure Waveguide

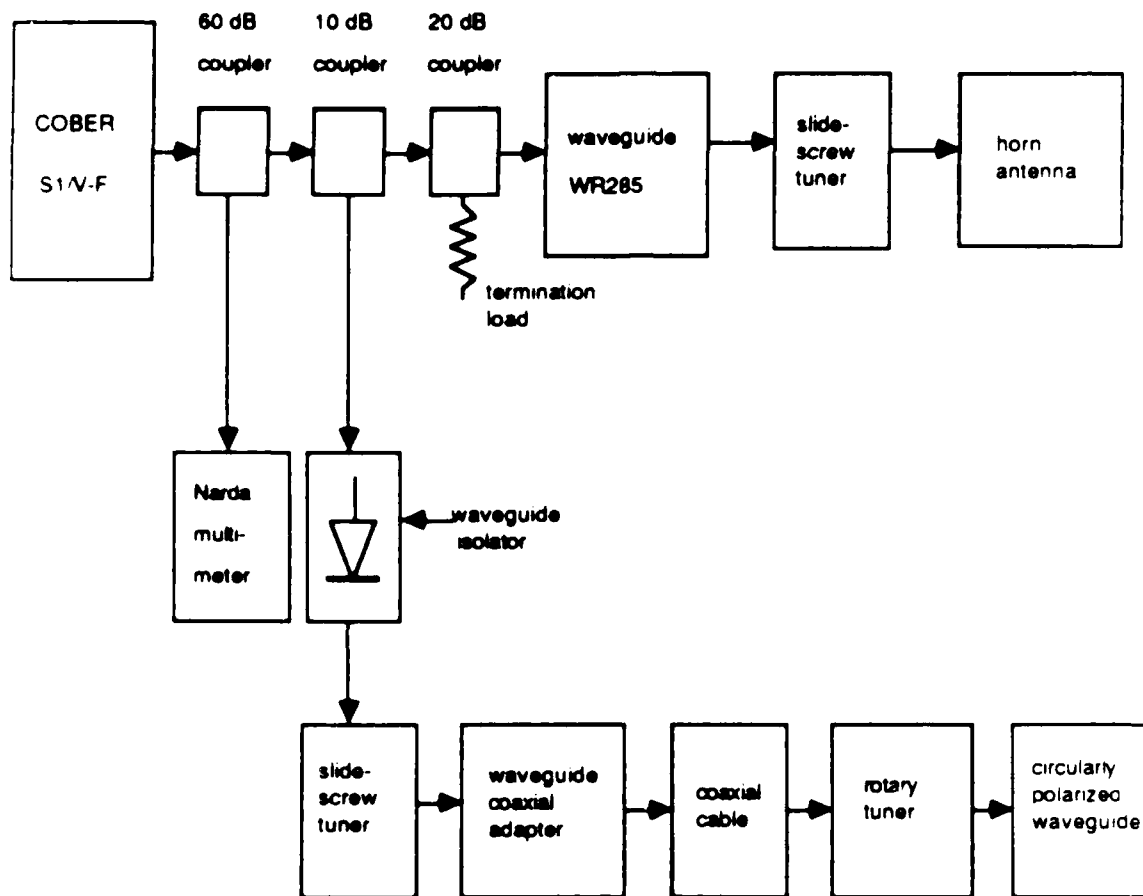

Figure 5 Microwave Distribution Schematic

Aluminium
grille windows

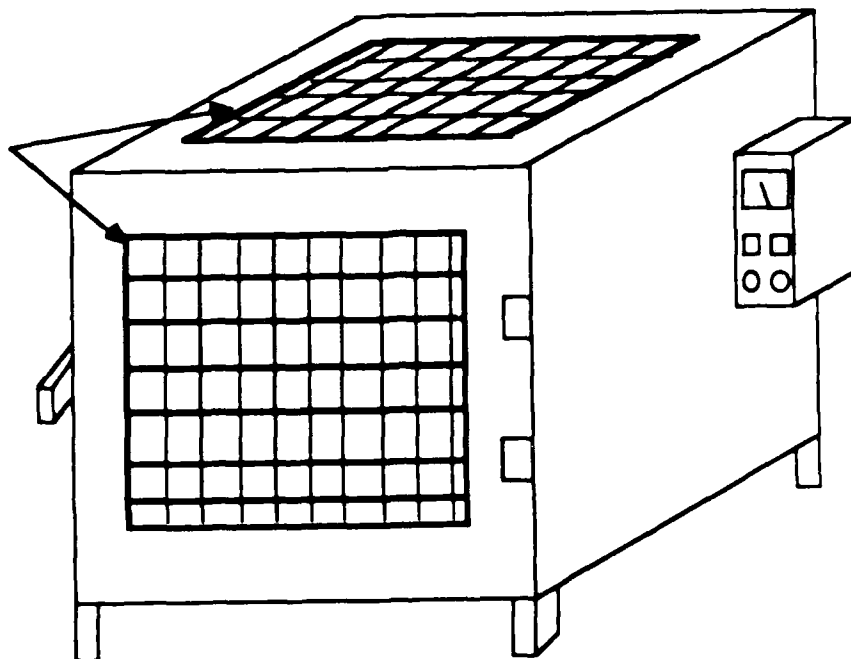

Figure 6 Multimodal Cavity

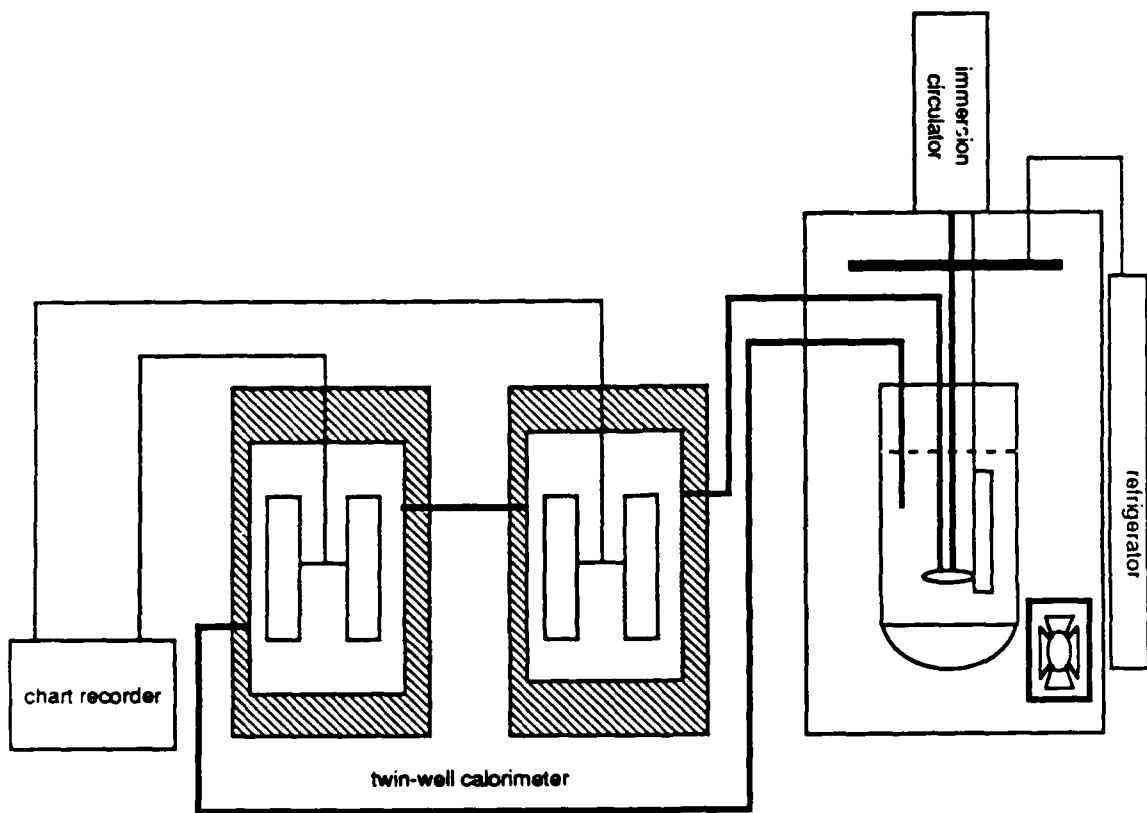

Figure 7 Diagram of Twin-Well Calorimetry System

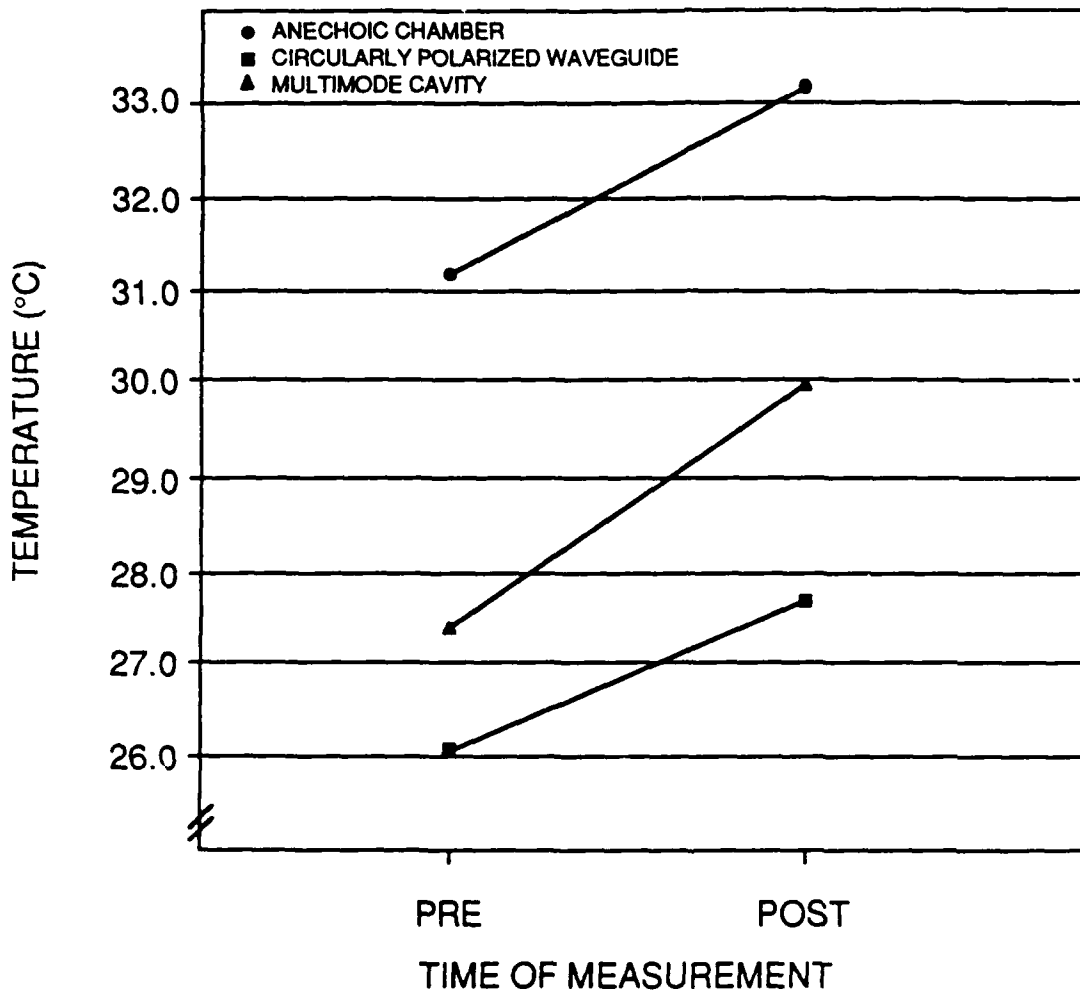

Figure 8: Pre-exposure and post-exposure brain temperatures for rat carcasses exposed at 2450 MHz in an anechoic chamber, a multimode cavity or a circularly polarized waveguide at an average whole body SAR of 10 W/kg for 15 minutes.

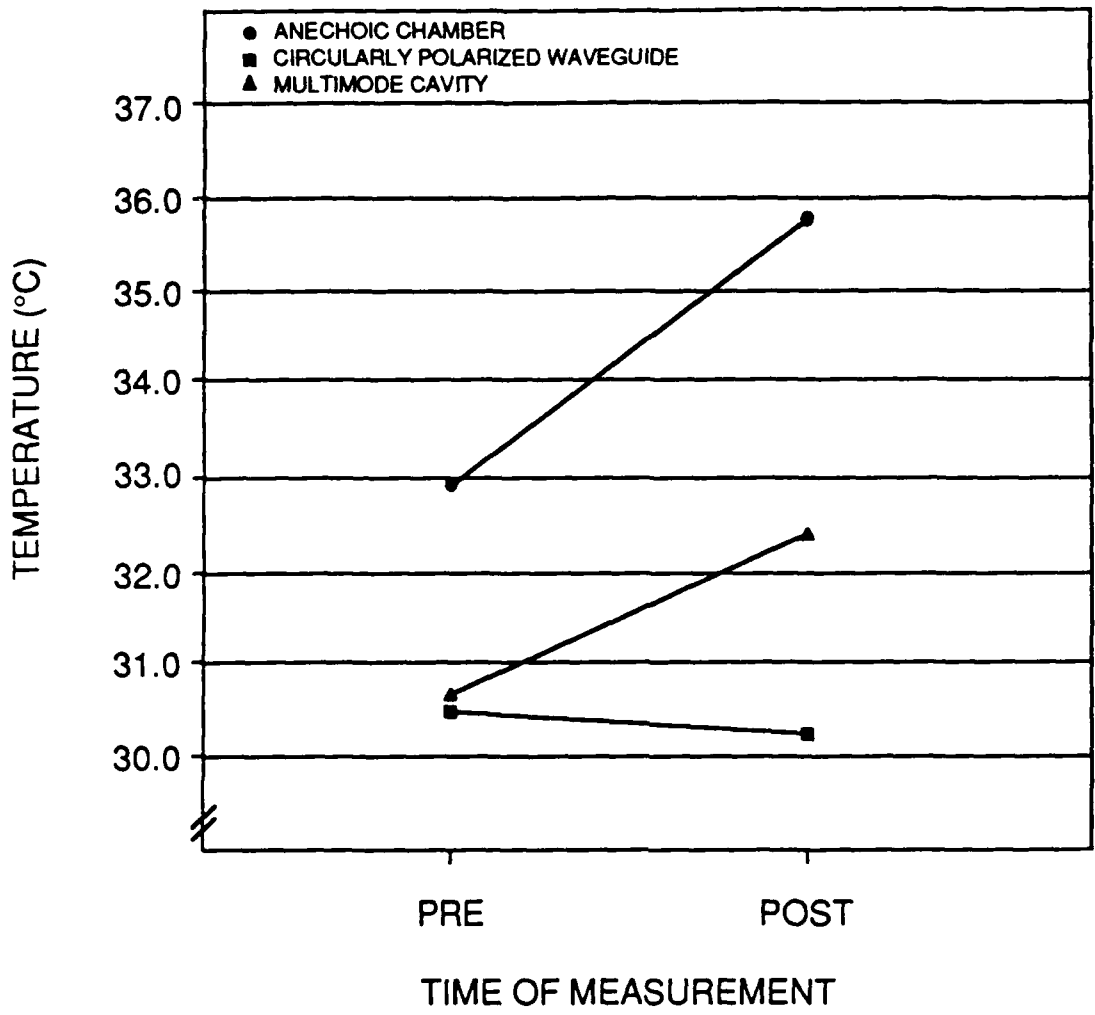

Figure 9: Pre-exposure and post-exposure colonic temperatures for rat carcasses exposed at 2450 MHz in an anechoic chamber, a multimode cavity or a circularly polarized waveguide at an average whole body SAR of 10W/kg for 15 minutes.

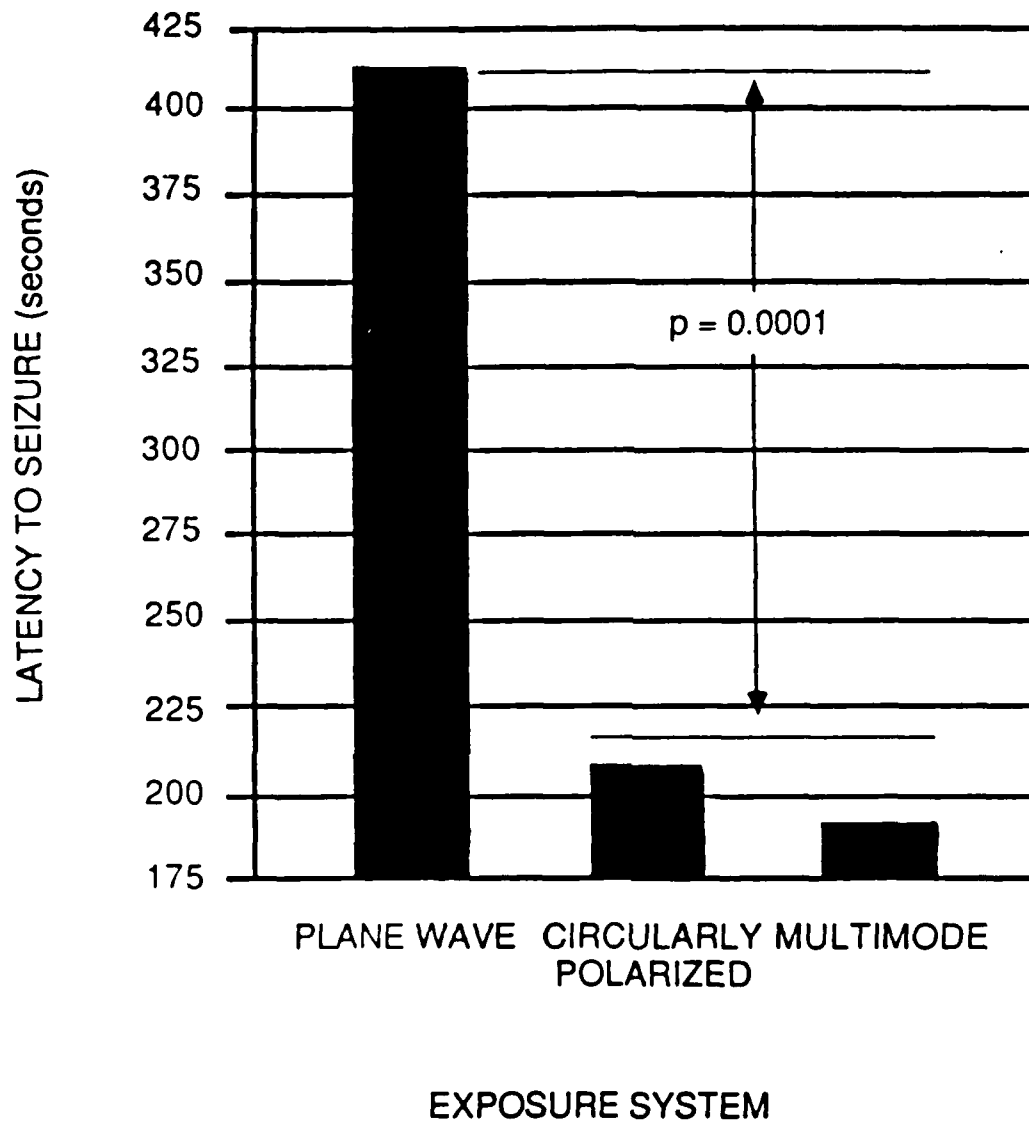

Figure 10: Latency to seizure in seconds for CF-1 mice exposed at 2450 MHz in an anechoic chamber, a circularly polarized waveguide or a multimode cavity.

ATE
MED
-88