

NO-A178 963

CALIBRATION OF THE HAND HELD LIDARS USED BY THE NAVAL
OCEAN SYSTEMS CENTER(U) NAVAL OCEAN SYSTEMS CENTER SAN
DIEGO CA J A FERGUSON ET AL. AUG 86 NOSC/TD-996

1/1

UNCLASSIFIED

RM395314207

F/G 17/9

NL



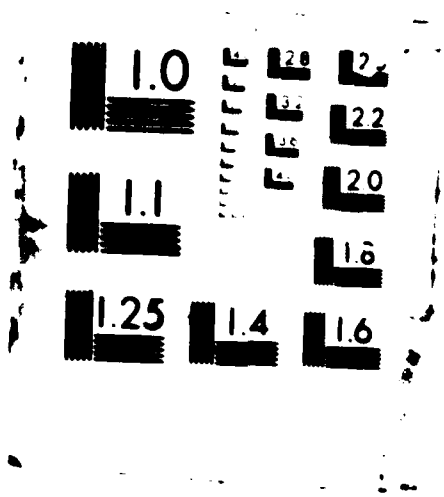

NOSC
NAVAL OCEAN SYSTEMS CENTER San Diego, California 92152-5000

DTIC FILE COPY

12

NOSC TD 996

Technical Document 996
December 1986

Calibration of the Hand-Held Lidars Used by the Naval Ocean Systems Center

AD-A178 965

DTIC
ELECTE
APR 06 1987
S D
D

J. A. Ferguson
M. R. Paulson



Approved for public release; distribution is unlimited

NAVAL OCEAN SYSTEMS CENTER

San Diego, California 92152-5000

E. G. SCHWEIZER, CAPT, USN
Commander

R. M. HILLYER
Technical Director

ADMINISTRATIVE INFORMATION

The work reported here was performed by members of the Modeling Branch, Ocean and Atmospheric Sciences Division, NAVOCEANSYSCEN, in association with the Physics and Electronics Laboratory, Netherlands National Defence Research Organization (TNO). Funding was provided by the Office of the Chief of Naval Research, Code 23.

Released by
J.A. Ferguson, Head
Modeling Branch

Under authority of
J.H. Richter, Head
Ocean and Atmospheric
Sciences Division

RH

AD-A178965

REPORT DOCUMENTATION PAGE

1a REPORT SECURITY CLASSIFICATION UNCLASSIFIED		15 RESTRICTIVE MARKINGS	
2a SECURITY CLASSIFICATION AUTHORITY		3 DISTRIBUTION/AVAILABILITY OF REPORT Approved for public release; distribution is unlimited.	
2b DECLASSIFICATION/DOWNGRADING SCHEDULE			
4 PERFORMING ORGANIZATION REPORT NUMBER(S) NOSC/TD-996		5 MONITORING ORGANIZATION REPORT NUMBER(S)	
6a NAME OF PERFORMING ORGANIZATION Naval Ocean Systems Center	6b OFFICE SYMBOL <i>(if applicable)</i> Code 544	7a NAME OF MONITORING ORGANIZATION	
6c ADDRESS (City, State and ZIP Code) San Diego, CA 92152-5000		7b ADDRESS (City, State and ZIP Code)	
8a NAME OF FUNDING/SPONSORING ORGANIZATION Office of the Chief of Naval Research	8b OFFICE SYMBOL <i>(if applicable)</i> Code 23	9 PROCUREMENT INSTRUMENT IDENTIFICATION NUMBER	
8c ADDRESS (City, State and ZIP Code) Arlington, VA 22217-5000		10 SOURCE OF FUNDING NUMBERS	
		PROGRAM ELEMENT NO 62759N	AGENCY ACCESSION NO DN488-760
		PROJECT NO RW59-551-4207	TASK NO 540-CD86
11 TITLE (Include Security Classification) Calibration of the Hand-Held Lidars Used by the Naval Ocean Systems Center			
12 PERSONAL AUTHOR(S) J.A. Ferguson, M.R. Paulson			
13a TYPE OF REPORT Final	13b TIME COVERED FROM 17 Mar 86 TO 27 Mar 86	14 DATE OF REPORT (Year, Month, Day) August 1986	15 PAGE COUNT 18
16 SUPPLEMENTARY NOTATION			
17 COSATI CODES		18 SUBJECT TERMS (Continue on reverse if necessary and identify by block number)	
FIELD	GROUP	SUB-GROUP	Lidar, mini lidar, visioceillometer, signal processing, calibration
19 ABSTRACT (Continue on reverse if necessary and identify by block number) <p>A program of lidar measurements to determine the characteristics of lidar equipment and to make side-by-side comparisons of lidar returns was conducted. The equipment consisted of the "mini lidar" developed by the Physics and Electronics Laboratory (FEL) of the Netherlands National Defence Organization (TNO) and the "visioceillometer" developed by the US Army's Atmospheric Sciences Laboratory. This report presents results of the program, including the energy output of the laser and the output of the signal-processing unit for varying input powers (calibration), as well as the results of comparative atmospheric measurements.</p>			
20 DISTRIBUTION AVAILABILITY OF ABSTRACT <input type="checkbox"/> UNCLASSIFIED UNLIMITED <input checked="" type="checkbox"/> SAME AS RPT <input type="checkbox"/> DTIC USERS		21 ABSTRACT SECURITY CLASSIFICATION UNCLASSIFIED	
22a NAME OF RESPONSIBLE INDIVIDUAL J.A. Ferguson		22b TELEPHONE (Include Area Code) (619) 225-2974	22c OFFICE SYMBOL Code 544

UNCLASSIFIED

SECURITY CLASSIFICATION OF THIS PAGE (When Data Entered)

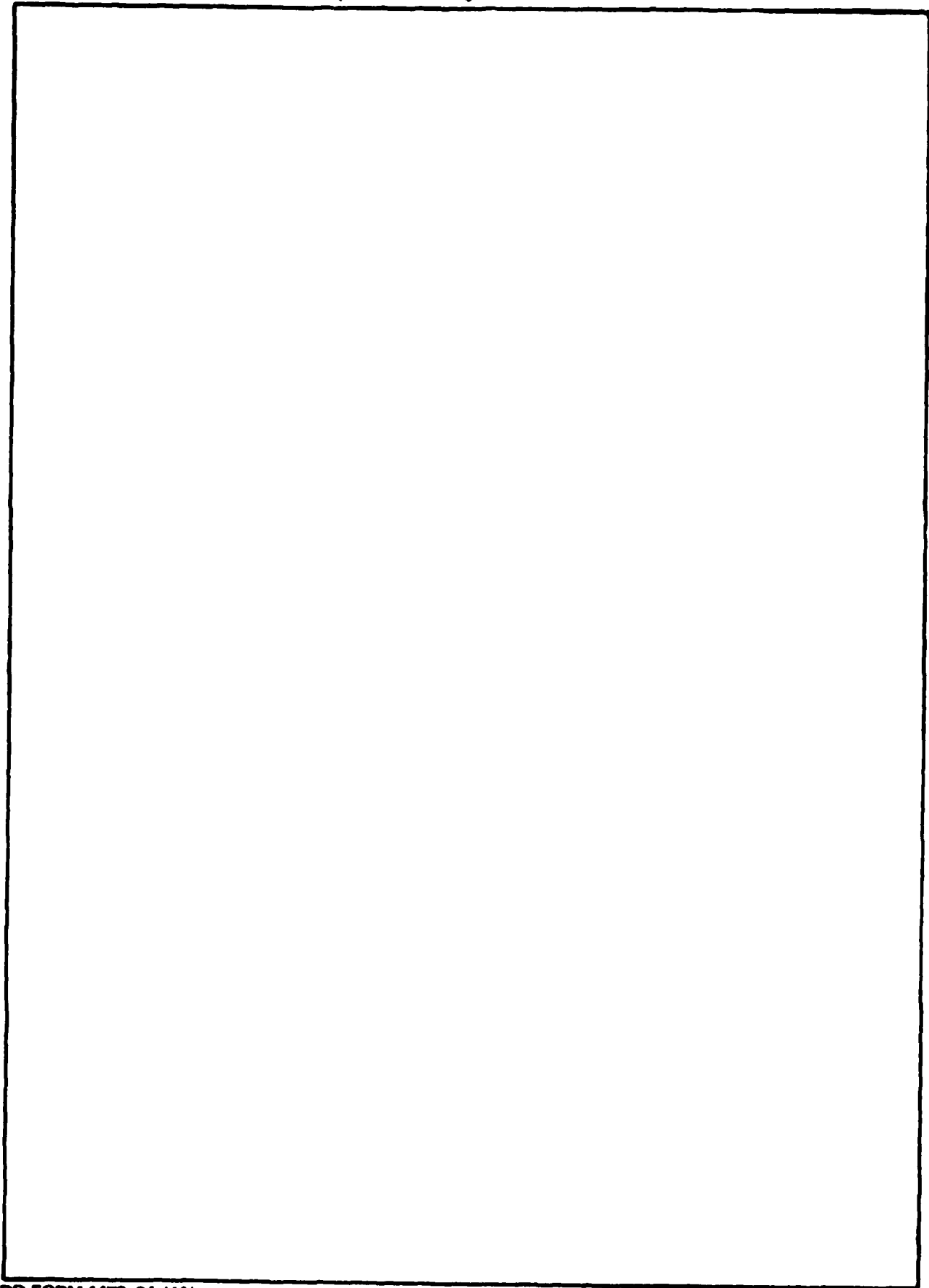

DD FORM 1473, 84 JAN

UNCLASSIFIED

SECURITY CLASSIFICATION OF THIS PAGE (When Data Entered)

CONTENTS

INTRODUCTION	page 1
ENERGY OUTPUT	1
CALIBRATION	2
MISCELLANEOUS	8
SIDE-BY-SIDE MEASUREMENTS	9
PLANS	12



Accession For		
NTIS CRA&I		<input checked="" type="checkbox"/>
DTIC TAB		<input type="checkbox"/>
Unannounced		<input type="checkbox"/>
Justification		
By		
Distribution		
Availability Codes		
Dist	Avail and/or Special	
A-1		

INTRODUCTION

From 17 through 27 March 1986, a joint program of lidar measurements was conducted at the Physics and Electronics Laboratory (FEL) of the Netherlands National Defence Research Organization (TNO), located in The Hague. The participants were from FEL and the Naval Ocean Systems Center (NOSC). The program consisted of a series of measurements to determine characteristics of the lidar equipment and to make side-by-side comparison of lidar returns. The equipment consisted of the "mini lidar" developed by FEL and the "visioceilometer," developed by the US Army's Atmospheric Sciences Laboratory (ASL), which is used by NOSC. This report will describe the data collected pertaining to the visioceilometer.

The visioceilometer consists of a hand-held, battery-operated lidar, a signal-processing unit, and a digital tape recorder.¹ The optical unit is a modified AN/GVS-5 laser rangefinder that emits, nominally, a 10-mJ, 6-ns pulse at 1.06 μm . The signal-processing unit clocks the return signal through a transient recorder at a 20-MHz rate. The digitized results are transferred to the tape recorder for off-line computer processing. NOSC has two of these systems, designated Units 0 and 1. Several kinds of measurements were performed, including the energy output of the laser and the output of the signal-processing unit for varying input powers (calibration). Following these performance assessments, a number of atmospheric measurements were made to compare the lidar of FEL with that used by NOSC.

ENERGY OUTPUT

This measurement consisted of several shots of the lidar into an EG&G Model 580-11A Radiometer. Unit 0 produced an average energy of 12.7 mJ, with a standard deviation of 0.28 mJ in 20 shots. Unit 1 produced an average of 11.1 mJ, with a standard deviation of 0.37 mJ in 24 shots. The visioceilometers monitor the laser output energy, and the signal-processing unit records a reference value on the tape recorder that is supposed to be proportional to this energy. This value is used in the computer program to compensate for variations of the laser energy with respect to the nominal value of 10 mJ. The reference value used for this monitor is 470. For unit 0, the monitor value varied from 1307 to 1491; for Unit 1, it varied from 686 to 1462. These monitor values are 1.5 to 3 times larger than the reference value, while the measured energies were no more than 1.3 times larger than 10 mJ. Furthermore, the variations in the monitor values did not follow the variations in the measured energy output, in that the monitor value did not consistently increase when the energy output increased. Thus the monitor values of these units are not reliable for correcting the lidar returns as recorded on tape.

¹ Lentz, W.J., The Visioceilometer: A Portable Visibility and Cloud Height Lidar, ASL-TR-0105, 1982.

CALIBRATION

The calibration was done in two stages. The first stage was conducted on a laboratory bench. The second stage was performed as a field measurement. The setup for the first stage of the calibration is illustrated in figure 1. The procedure followed is a "black box" calibration, since the receiver optics, transient recorder, and amplifier circuits are all included in the measurements. The firing of the laser was detected by the photodiode, which caused the triggering device to produce a pulse of

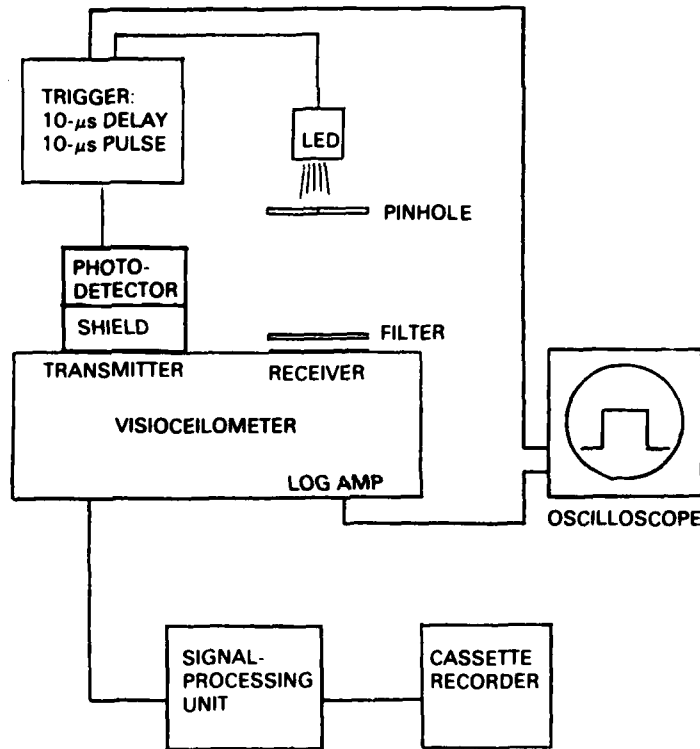

Figure 1. Diagram of the benchtop setup used for the first stage of the calibration.

10- μ s duration from the LED. The pulse was delayed long enough to be detected by the lidar receiver. Calibrated filters were introduced between the LED and the receiver to produce attenuation of the signal. These measurements were made without the pinhole (fig 1). Introduction of the pinhole requires precise positioning of the receiver, but it produces a known amount of energy incident upon the receiver (197 nW). The data for the calibrations should be fit by a polynomial function, $L(Y)$, which gives the value of the power incident on the detector, P , as a function of the digitizer output, Y :

$$\log_{10} P = L(Y)$$

The data-reduction programs currently assume that $L(Y)$ is a straight line whose slope is directly related to that of the logarithmic amplifier in the lidar detection system (V_{dB}). This slope has a value of 819.2 (with $V_{dB} = 0.01$) and an intercept of 6930.

During the calibration, the output from the logarithmic amplifier of the visioceilometer was connected to an oscilloscope to confirm proper operation and detection of the lidar return. This was done partly because the performance of the visioceilometers is very sensitive to the condition of the batteries. This problem was partially alleviated by connecting a power supply to the signal-processing unit to keep the batteries charging continuously.

The calibration procedure consisted of making 2 or 3 shots without any filters, and then with a set of calibrated filters. A final set of measurements was made with the pinhole inserted between the LED and the receiver, completing the calibrations.

For Unit 0, the oscilloscope trace and the recorded data showed a high dc offset accompanied by a rapid fluctuation suggestive of noise. This resulted in the calibration pulse disappearing into the background after 20 dB of attenuation. Unit 1 did not display these problems and permitted calibration through 30 dB, down to the dc offset level. Because of the inferior performance of Unit 0 compared to that of the other unit, it was not used in subsequent measurements. The results of the first stage of the calibration for Unit 1 are presented in figure 2. The vertical axis represents the digitizer output. Note the significant nonlinearity of the system output. It has not been possible to determine the cause of this result. The best fit straight line has a slope of 822.4.

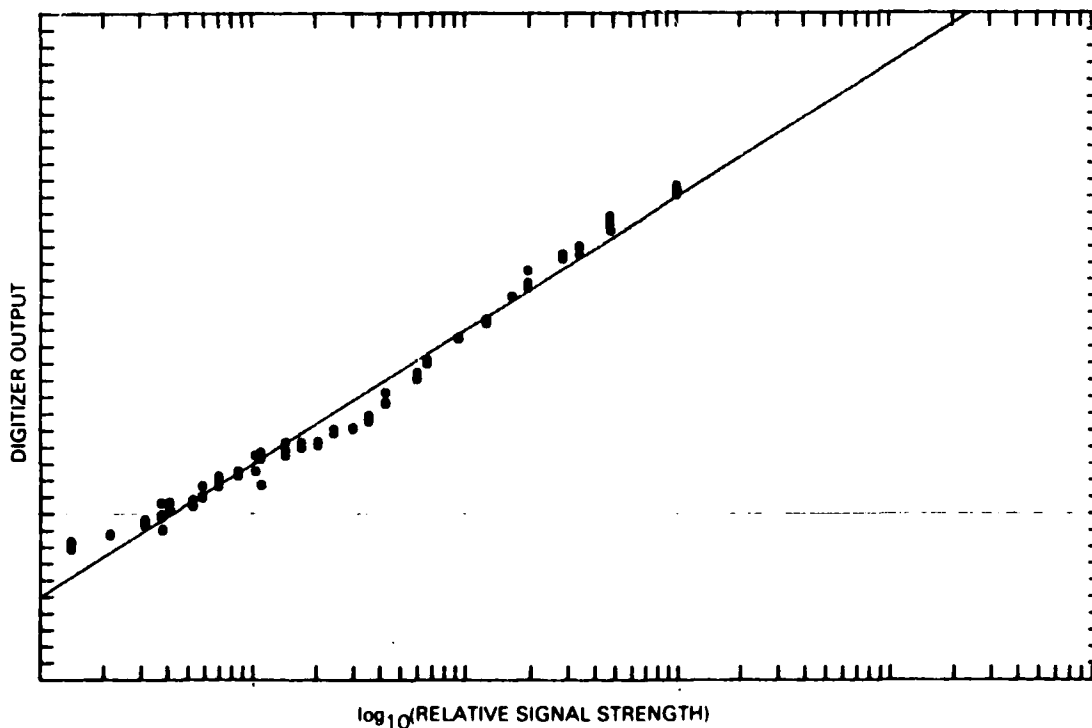

Figure 2. Digitizer output as a function of relative signal level, using the calibrated source in the setup shown in figure 1.

The second stage of the calibration was necessary because of the low power of the LED that provided the calibration signal in the benchtop setup. The range of the data, as seen in the digitizer output, is from about 740 to 4095. The first stage of the calibration produced output up to 2000. In the second stage, the lidar was fired horizontally towards a hard target (in this case a radar dome about 839 m away). When no filters were present, returns from the target produced digitizer outputs at the maximum possible value. Introducing the filters attenuated the signal to the extent that the returns overlapped the results from the first stage of the calibration. As in the first stage of calibration, several shots were made with each filter.

The original plan was to use the returns from the hard target as data for this stage of the calibration. However, the sampling interval of the lidar did not consistently detect the hard target. Instead, the magnitude of the first part of the atmospheric return was used. The results are presented in figure 3. The best fit straight line has a slope of 925.7, a significant departure from the value of 819.2 used in the past.

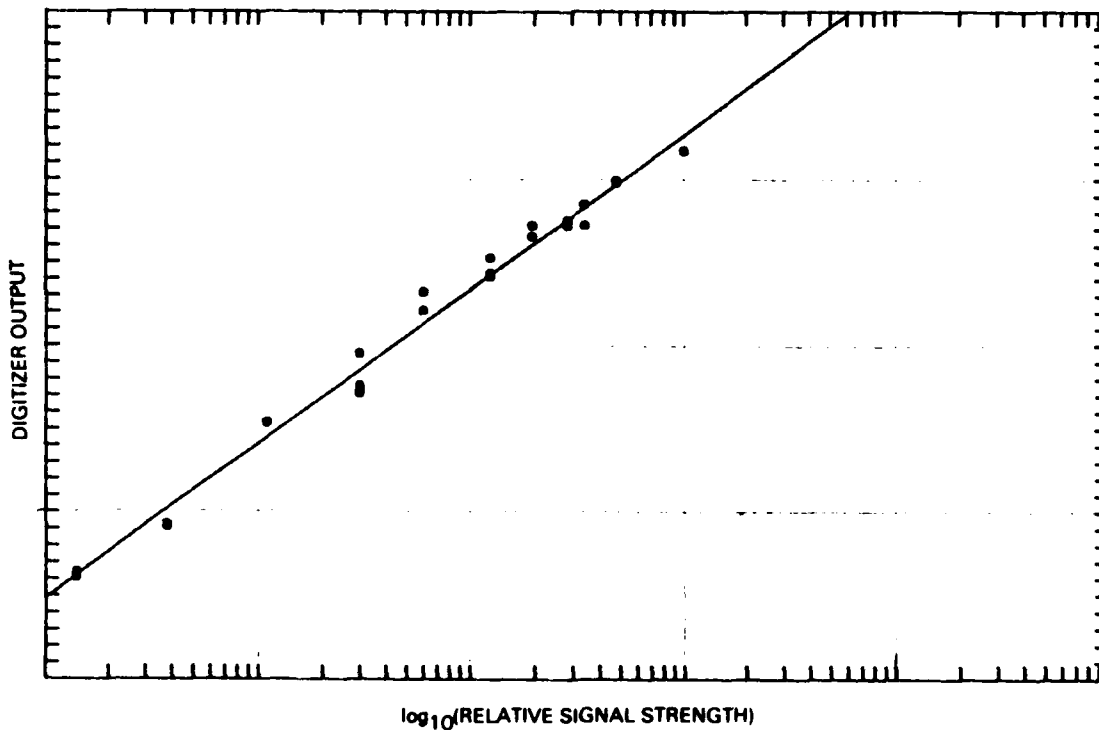

Figure 3. Digitizer output as a function of relative signal level, using atmospheric returns. The solid line represents the best fit straight line to the data.

The two calibrations were combined by overlaying figures 2 and 3 and sliding them horizontally until data values in the two figures were at about the same locations vertically. This point was such that the 100% point of figure 2 was aligned with the 9% point of figure 3. To eliminate the effect of the nonlinearity of the data for small values of the digitizer output, a straight line was fitted to only those output values

greater than 1400. The results are shown in figure 4. The slope of the best fit straight line is 880.2, still quite different from the original value used in the data-processing programs. Using this slope and the results of the pinhole measurement, the intercept of the straight line is 7822.

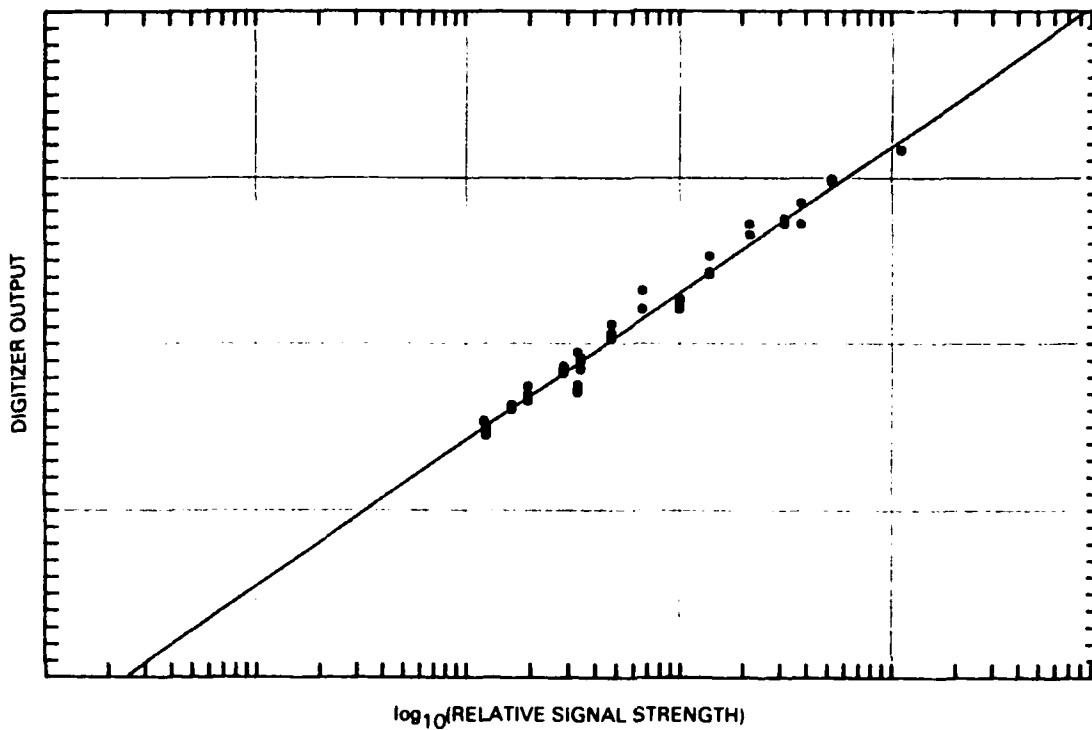

Figure 4. Combination of data from figures 2 and 3, using only digitizer output values greater than 1400. The data of figure 3 have been adjusted horizontally by a factor of 100/9 to give a reasonable overlay of the two different sets of data.

The data in figures 2, 3, and 4 suggest the use of a polynomial to convert digitizer output to power incident on the detector. Such an approach was examined by fitting polynomials (using a least-squares method) to $\ln(P)$ versus digitizer output, Y . Results for the linear and cubic polynomials are shown in figure 5. The cubic curve seems to be a good fit to the data. The calculated $S(r)$ using the two different calibration curves is shown in figure 6. The straight lines overlying the data are best fits to the $S(r)$ data over the range between 200 and 1000 meters. In the case using the cubic fit, the overall trend of $S(r)$ is to increase with range while the other calibration curve results in $S(r)$ decreasing with range. It would appear that the calibration data of figures 2, 3, and 4 are not sufficiently precise to warrant more than a linear fit.

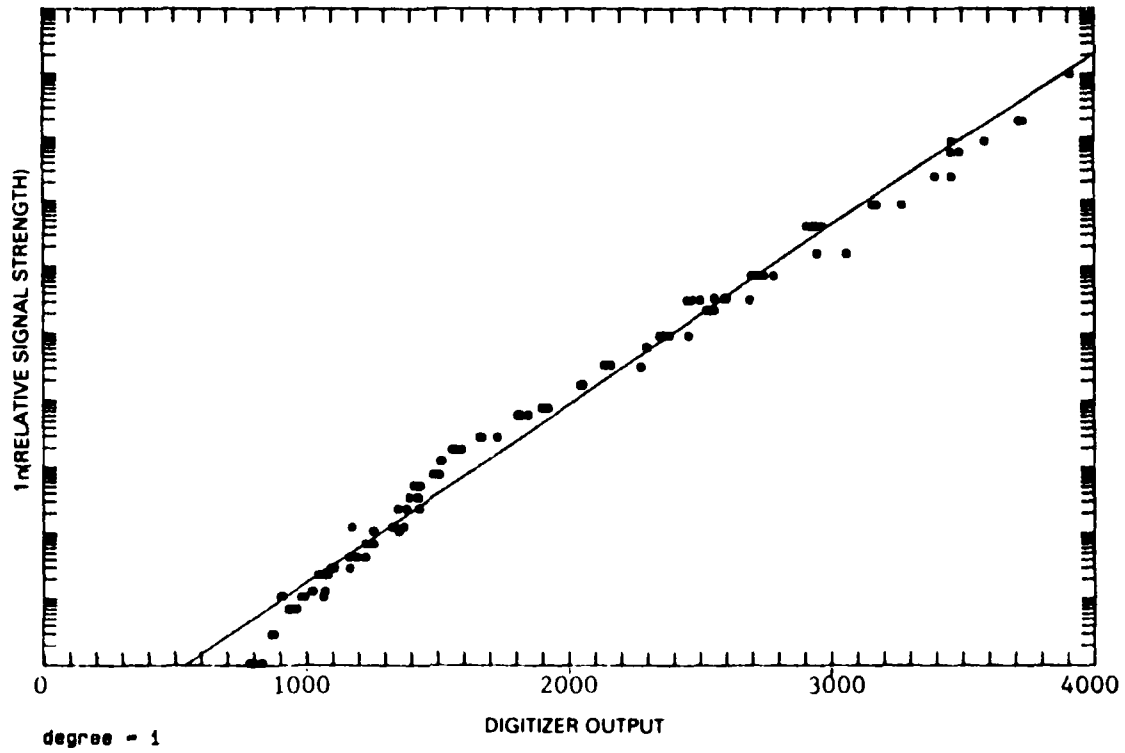
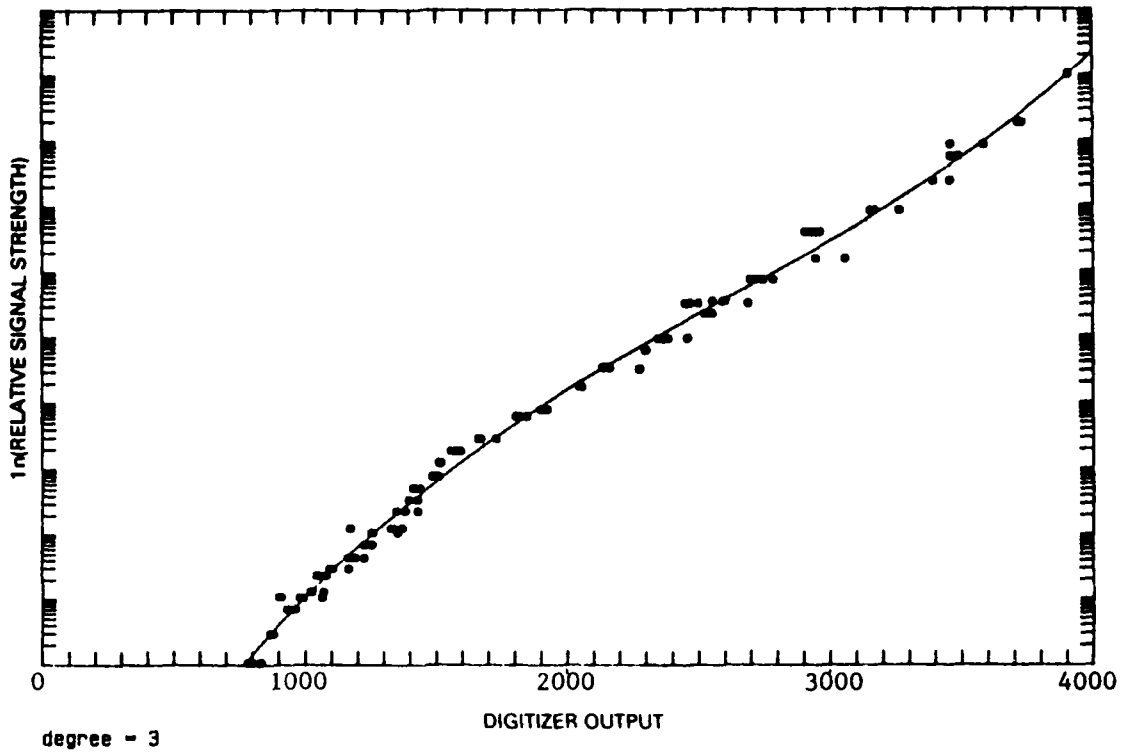
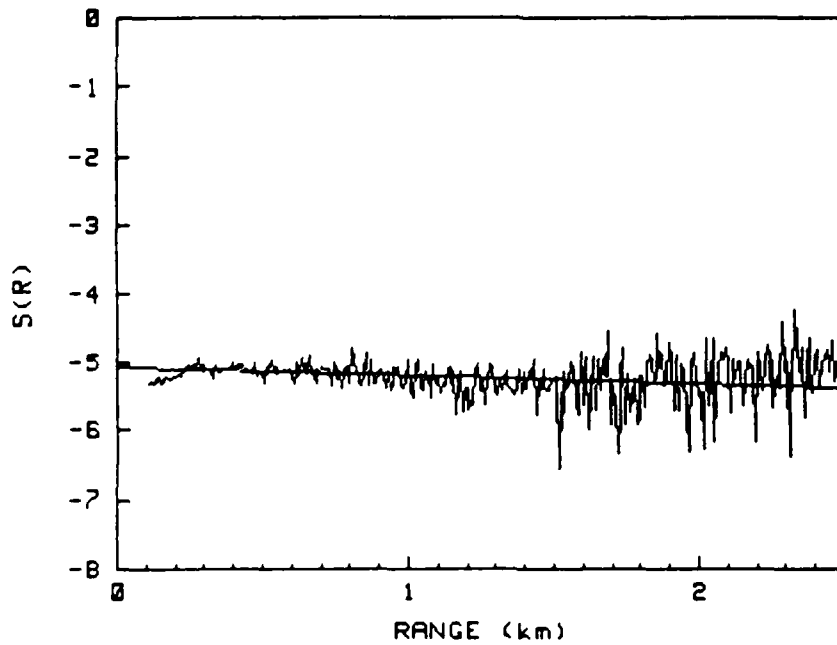
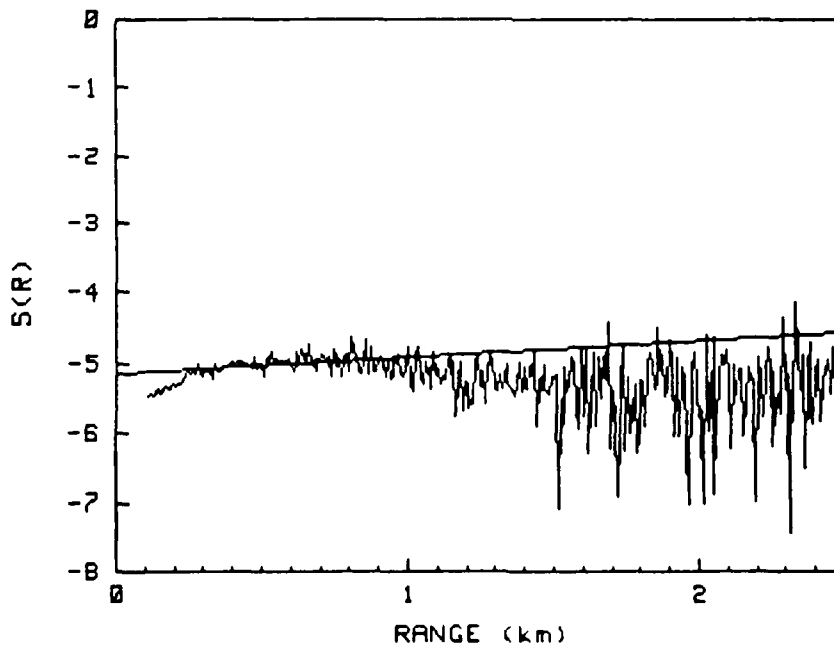

Figure 5. Linear (degree = 1) and cubic (degree = 3) fits to the calibration data displayed as $1 n(\text{relative signal strength})$ versus digitizer output.



24MAR86 1 SHOT 30 DEG 1 SHOT HORIZ. LIDAR #025091 NEW CAL (05 AUG 86)
 DATA SET 2 Delay=2710
 1st degree polynomial



24MAR86 1 SHOT 30 DEG 1 SHOT HORIZ. LIDAR #025091 NEW CAL (05 AUG 86)
 DATA SET 2 Delay=2710
 3rd degree polynomial

Figure 6. Results of using the polynomials of figure 5 to calculate $S(r)$ for a sample horizontal shot.

MISCELLANEOUS

Several measurements were made to assess the response of the detector to an impulse and to a step input. The results show that the system is very good in this respect. One result of the calibration procedure is cause for some concern, although the magnitude of the problem is not readily assessable. This result is illustrated in figure 7, which shows the raw data from the signal-processing unit as recorded on the cassette tape. The cause for concern is that prior to the pulse, the apparent noise level is near 700, whereas after the pulse is turned off there is an apparent residual signal that starts at a level of about 1000 and then decays slowly. It is expected that the level should return abruptly to 700. The extent to which large, rapid fluctuations in an atmospheric return may produce similar residuals is not known.

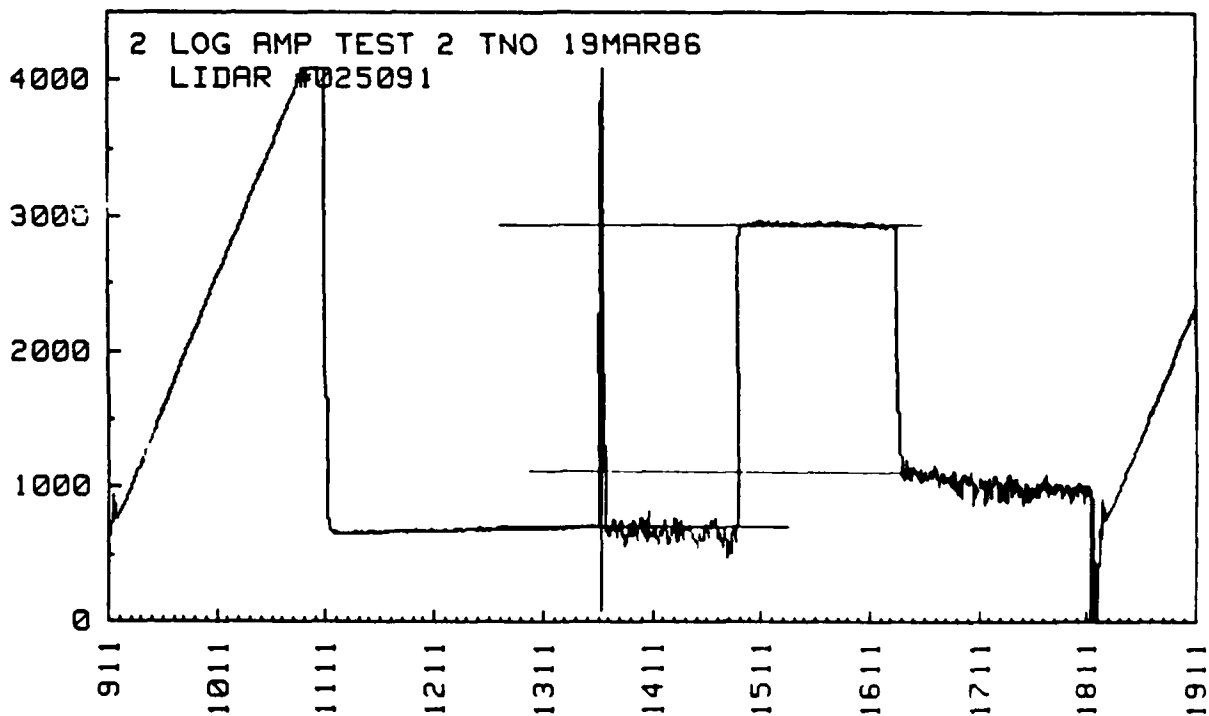

Figure 7. Raw data for one of the calibration data points showing the incomplete return to the prepulse level.

Finally, a crude estimate of the beam divergence was made by firing the laser down an optical corridor of 50 m length, observing the reflection with a hand-held infrared detector, and measuring the diameter of the circle. This measurement showed a beam diameter of 10 cm at 50 m (2 mrad). The variation of the sampling rate was assessed by looking at the positions of the radar dome (when it was detected) during the second stage of the calibration. The return from this hard target was always in sample number 120 or 121, indicating very good stability in the range resolution.

SIDE-BY-SIDE MEASUREMENTS

After the performance of the equipment under special conditions was determined, a series of measurements of the atmosphere was made. A sample pair of raw data curves is shown in figure 8a-b and the corresponding $S(r)$ curves are shown in figure 9a-b. The curves in figures 8a and 9a are for shots made at an elevation of 30° , directed toward a cloud base that is readily evident. The curves in figures 8b and 9b are for horizontal shots. These latter data seem to indicate horizontal homogeneity. Comparing the curve in figure 8a with similar data from FEL, it is evident that the slope of the data from the visiocilometer is smaller than that of the data from FEL.

In most cases, the returns obtained by FEL were similar to those of NOSC in form. However, there is a consistent offset between the two sets of data. Several measurements were made at elevation angles of about 30° directed toward the base of the cloud cover. In these cases, both sets of equipment showed the base of the cloud cover at the same range. Aside from the cases in which there was falling rain, the data seem to indicate that the atmosphere was essentially homogeneous in the horizontal direction. A temporary modification to the FEL equipment was made so that only data in horizontal directions were collected during two consecutive nights. Again, aside from instances of rainfall, the data show the atmosphere to be sensibly homogeneous. However, it is difficult to evaluate this conclusion because of the very small size of the FEL displays. It would be most helpful in future experiments to display the FEL data with more detail.

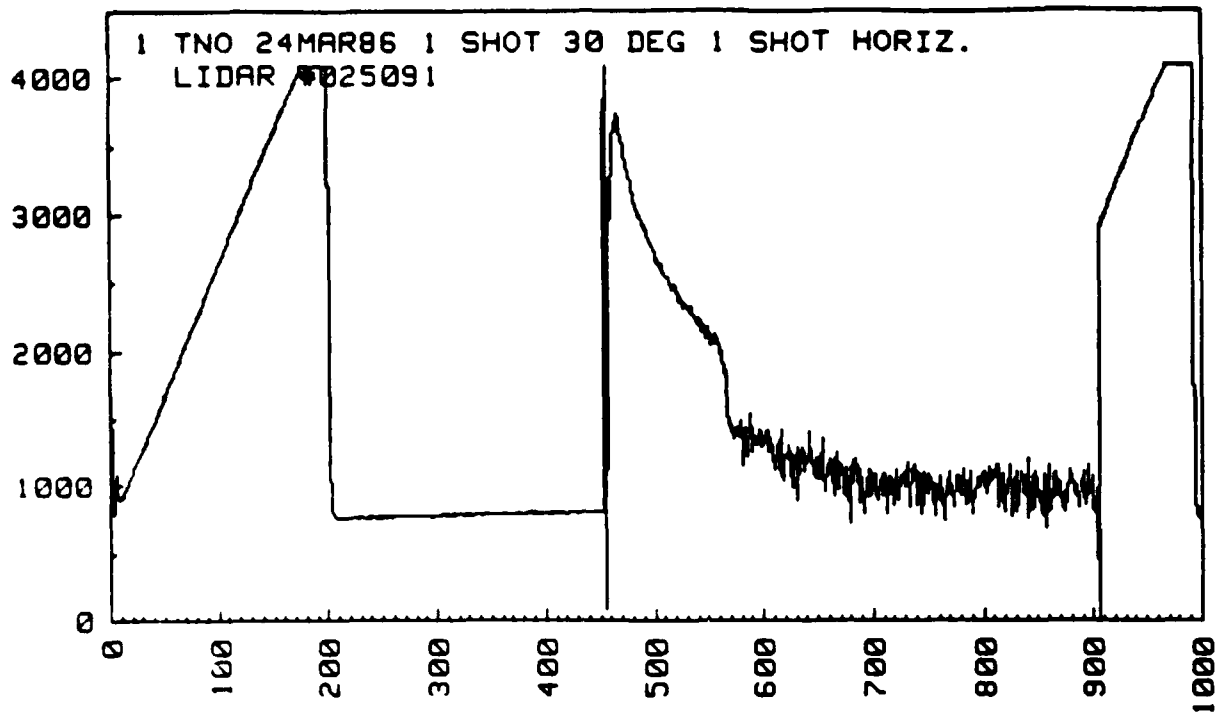

Figure 8a Raw data obtained during atmospheric measurements. Laser fired at an elevation angle of 30°

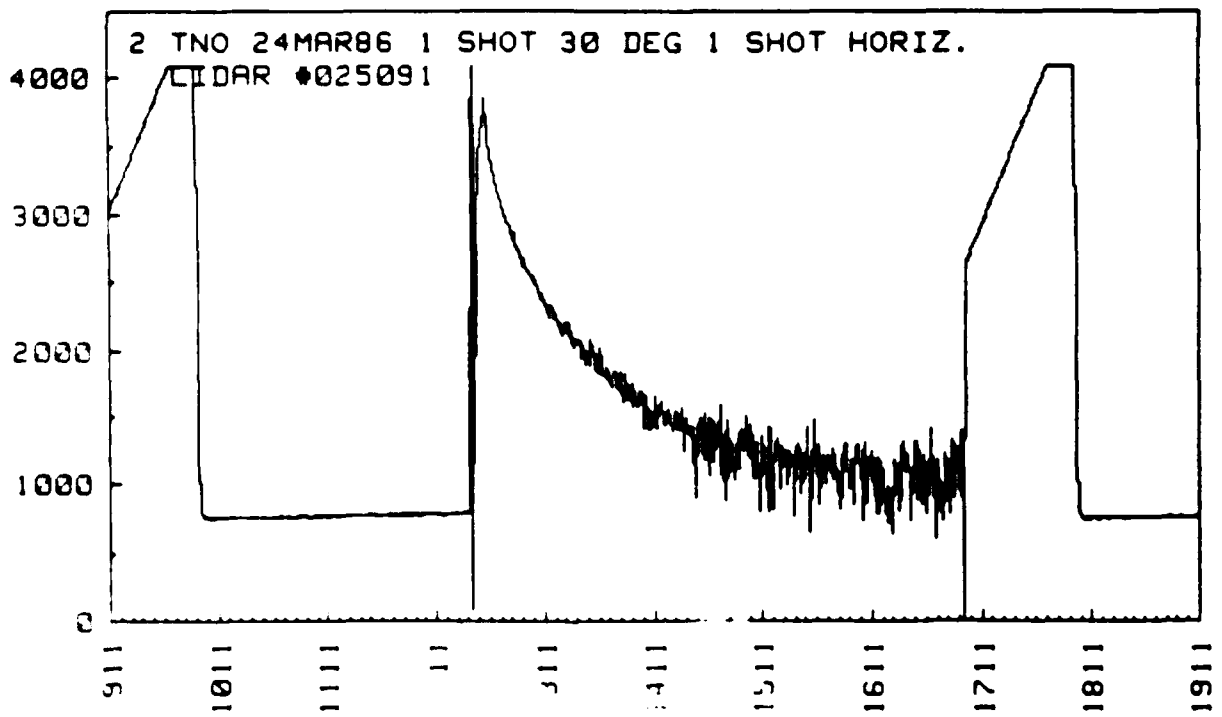
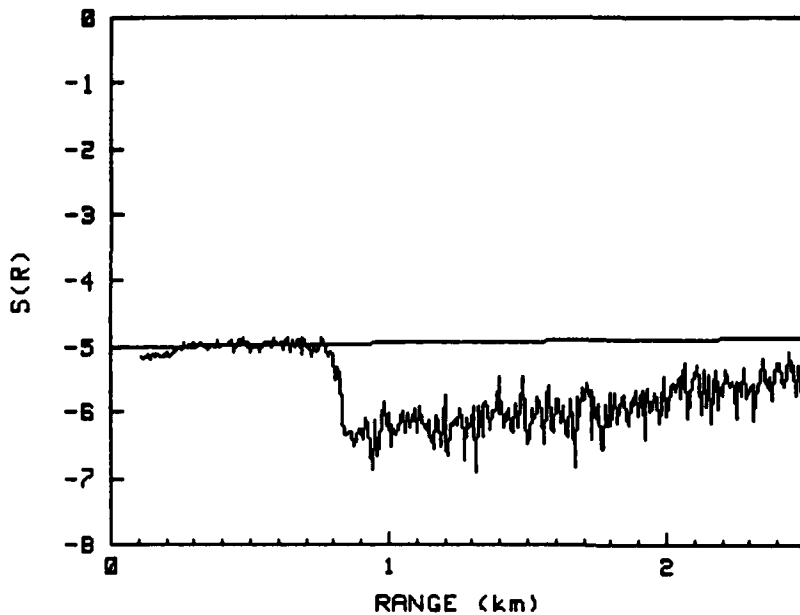
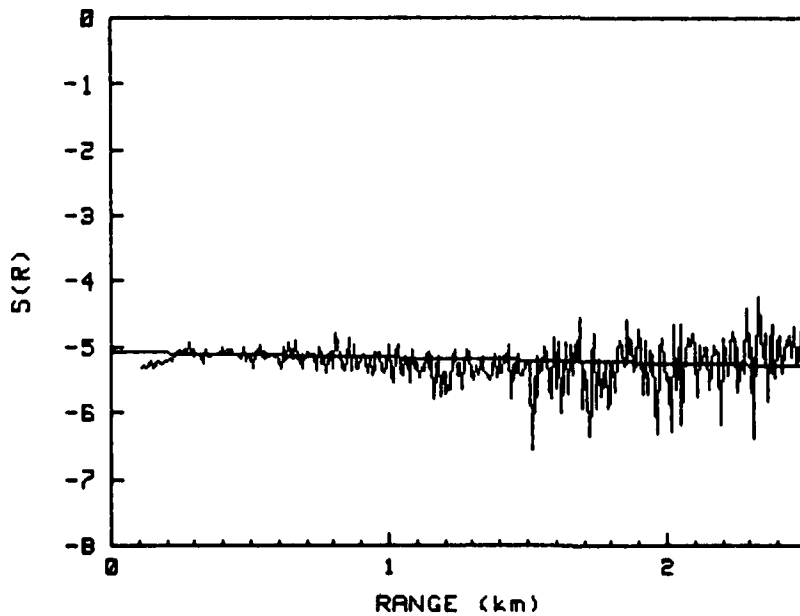

Figure 8b Raw data obtained during atmospheric measurements. Laser fired horizontally



(a)

24MAR86 1 SHOT 30 DEG 1 SHOT HORIZ. LIDAR #025091 NEW CAL (05 AUG 86)
 DATA SET 1 Delay=2998
 1st degree polynomial
 Curve fit $Y = -5.012 + .0529 * X$ From 0.20 to 0.80 km
 Correlation= 0.1267



(b)

24MAR86 1 SHOT 30 DEG 1 SHOT HORIZ. LIDAR #025091 NEW CAL (05 AUG 86)
 DATA SET 2 Delay=2710
 1st degree polynomial
 Curve fit $Y = -5.082 - .0888 * X$ From 0.20 to 0.80 km
 Correlation=-0.1720

Figure 9. $S(r)$ curves for the data in figure 8. The straight line is the best fit over the range between 200 and 800 meters.

PLANS

The homogeneity in the horizontal direction observed by FEL needs to be quantified to facilitate comparisons of other measurements at other sites and to overcome the problem of their small display. The problems touched on in the body of this report, regarding the calibration and performance of the signal-processing unit of the visioceilometer, need to be resolved. These are basically hardware problems.

The workers at FEL have consistently found that their lidar returns indicate that the atmospheric aerosols are horizontally homogeneous in all the locations where they have made measurements. This has not been the case in San Diego. The Naval Ocean Systems Center has, at times, observed highly irregular lidar returns that would indicate pronounced horizontal inhomogeneity in the atmospheric aerosols. However, at times, returns are observed that would suggest horizontal homogeneity. To further investigate the possible inhomogeneities, one of the visioceilometers will be taken aloft in the NOSC leased aircraft. This aircraft is equipped to measure various meteorological parameters, as well as to measure aerosol distributions with the use of a particle measuring system.

The lidar will be fired horizontally from the side of the plane at intervals. The plane will be climbing or descending, either in a spiral or in a straight line. This will provide horizontal lidar returns as a function of altitude. This will be repeated for several different locations over the ocean near San Diego.

The lidar returns will be examined for evidence of homogeneity or inhomogeneity as a function of altitude and for the different locations. The result will be compared to those obtained from the particle measuring systems and the other meteorological data.

In cases in which the range-corrected lidar returns appear to be reasonably close to a straight line, these values will be compared as a function of altitude and also will be compared to the other meteorological data.

END

4-87

DTIC