

AD-A181 877 KINETICS OF INTRA AND INTER EXCITATION ENERGY TRANSFERS 1/1
(U) CORNELL UNIV ITHACA NY DEPT OF CHEMISTRY
S H BAUER ET AL 20 MAR 87 AFOSR-TR-87-0573
UNCLASSIFIED F49620-84-C-0031 F/G 7/4 NL

END
7-87
D/C

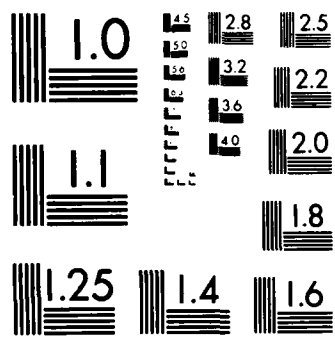

REPORT DOCUMENTATION PAGE

AD-A181 077 IC

1b. RESTRICTIVE MARKINGS

3. DISTRIBUTION/AVAILABILITY OF REPORT
Approved for public release;
Distribution unlimited

2b. DECLASSIFICATION/DOWNGRADING SCHEDULE

MAY 27 1987

4. PERFORMING ORGANIZATION REPORT NUMBER(S)

5. MONITORING ORGANIZATION REPORT NUMBER(S)
AFOSR-TR- 87-0573

6a. NAME OF PERFORMING ORGANIZATION
Cornell University

8b. OFFICE SYMBOL
(If applicable)

7a. NAME OF MONITORING ORGANIZATION,
Directorate of Chemical and
Atmospheric Sciences, AFOSR

6c. ADDRESS (City, State and ZIP Code)
Department of Chemistry
Ithaca, New York 14853-2801

7b. ADDRESS (City, State and ZIP Code)
Bldg 410
Bolling AFB, D. C. 20332-6448

8a. NAME OF FUNDING/SPONSORING
ORGANIZATION
AFOSR

8b. OFFICE SYMBOL
(If applicable)
NC

9. PROCUREMENT INSTRUMENT IDENTIFICATION NUMBER
F49620-84-C-0031

8c. ADDRESS (City, State and ZIP Code)
Bldg. 410
Bolling AFB, D. C. 20332-6448

10. SOURCE OF FUNDING NOS.			
PROGRAM ELEMENT NO.	PROJECT NO.	TASK NO.	WORK UNIT NO.
61102F	2303	B1	

11. TITLE (Include Security Classification)
Kinetics of Intra and Inter Excitation
Energy Transfers

12. PERSONAL AUTHOR(S)
Simon H. Bauer, assisted by: Drs. K. I. Lazaar and D. B. Borchardt

13a. TYPE OF REPORT
FINAL

13b. TIME COVERED
FROM 2/15/84 to 2/14/87

14. DATE OF REPORT (Yr., Mo., Day)
1987 March 20

15. PAGE COUNT
6

16. SUPPLEMENTARY NOTATION

17. COSATI CODES		
FIELD	GROUP	SUB. GR.

18. SUBJECT TERMS (Continue on reverse if necessary and identify by block number)
Gas phase kinetics; Rates over low barriers;
Relaxation times;
Intramolecular energy transfer rates

19. ABSTRACT (Continue on reverse if necessary and identify by block number)
The experimental results we developed during the course of this project, and their analyses concern the dynamics of systems undergoing intra- and inter-molecular conversions over low barriers, in the gas phase. As anticipated, for this large class of reactions, the observed relaxation times do not fully conform to the successful theories which were developed for reactions characterized by large activation energies. For some low E_a systems, departures from RRKM predictions, measured close to equilibrium conditions, indirectly provide measures of limiting IVR rates. Several intramolecular conversions (typically aziridine) and association/dissociations (typically: formic acid) were investigated.

20. DISTRIBUTION/AVAILABILITY OF ABSTRACT
UNCLASSIFIED/UNLIMITED SAME AS RPT. DTIC USERS

21. ABSTRACT SECURITY CLASSIFICATION
Unclassified

22a. NAME OF RESPONSIBLE INDIVIDUAL
Major Larry P Davis

22b. TELEPHONE NUMBER
(Include Area Code)
(202) 767-4963

22c. OFFICE SYMBOL
NC

COMPREHENSIVE FINAL REPORT

Unimolecular reaction rate theory, which required about three decades to become fully formulated as RRKM, is generally accepted as one of the major accomplishments of chemical kinetics. It is not an approximate solution of a realistic model; rather, it is an accurate solution of an idealized model. As developed in its present format it provides an algorithm for calculating the first order rate constant for the collision-free conversion of adequately energized molecules (A^*) to the transition structure (A^\ddagger), using only molecular parameters of the reacting species and of the postulated transition structure. When results of kinetic experiments are found to disagree with predictions based on an RRKM model, one of two explanations may apply:

(i) The trivial one --- the assumed mechanism may be in error. For example, a dissociation presumed to result from vibrational excitation may be due to a rate controlling displacement step followed by a rapid release of the attacking species. (ii) The more serious one --- intramolecular vibrational relaxation may be rate controlling (intrinsic non-RRKM). For example, when a substantial fraction of vibrationally excited molecules with $E > E_a$ incorporate the energy of excitation in states which are poorly coupled to those vibrations which characterize the transition structure. One anticipates that failures of type (ii) would occur for conversions over low barriers, where the densities of vibrational states are sparse, thus enhancing the possibility for significant energy mismatch between states. In identifying specific species for detailed study one should look for relatively small molecules in which the reaction coordinate appears to be localized in a bond involved in vibrational modes which are poorly coupled to a large fraction of the remaining molecular modes. These criteria point to kinetic systems which are undergoing rapid

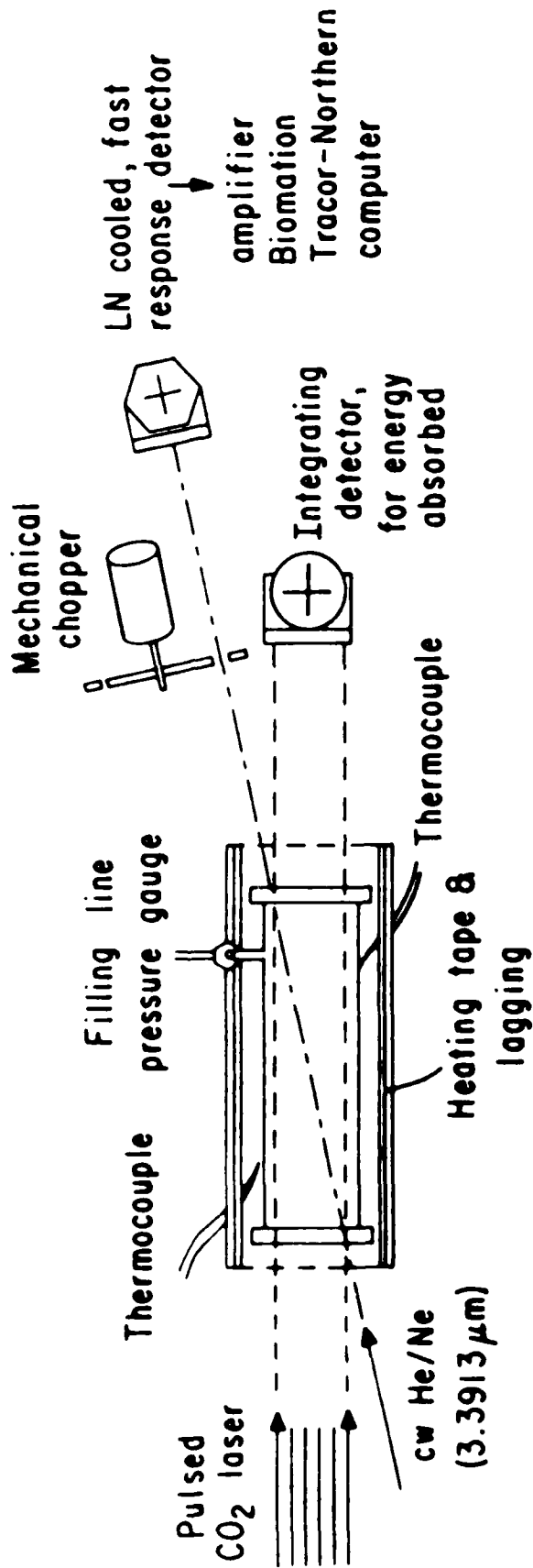

energy is 6.8 ± 1 kcal/mole. Furthermore, even though at the pressures used the system should be in the 2nd order regime, the addition of (10-600) Torr of Ar had no measurable effect on the rate. These observations can be reconciled by assuming that (i) the ring structure opens when a (free) monomer adds to one of the O-HO bonds in the dimer, thereby releasing one of the initial monomers and generating a chain dimer; (ii) the latter relatively rapidly dissociates into two monomers. On this basis we predicted that other OH-bonding species would show a linear pressure dependence of the rate. This proved to be the case; $(\text{CD}_3)_2\text{CO}$ is 0.036 as effective as HCOOH ; THF-d_8 is 0.022 as effective as HCOOH ; H_2O is comparable to acetone but difficult to reproduce due to wall-adsorptions. These results are consistent with their relative H-bonding power.

(ii) The rate of bond inversion at the nitrogen atom in aziridine (dimethylene-imine) was measured in the gas phase for a range of pressures and temperatures. ^1H NMR spectra were recorded of samples at 5-1100 torr, and from 298 to 388°K. Rate constants for inversion were derived by complete lineshape analysis of the NMR spectra. Their temperature dependence at the high pressure limit (1100 torr) gave $E_a = 15.8 \pm 0.4$ kcal mole $^{-1}$; $\Delta H^\ddagger = 15.2 \pm 0.4$ kcal mole $^{-1}$; $\Delta S^\ddagger = -5.5 \pm 3$ e.u.; and $\Delta G_{298}^\ddagger = 16.8 \pm 0.5$ kcal mole $^{-1}$. These values are in excellent agreement with previously reported magnitudes obtained for solutions and in the gas phase at high pressures. However, at all temperatures we found no dependence of the first order rate constants on pressure down to 5 torr, in sharp contrast to the fall-off curves calculated with standard RRKM codes, which indicated that for pressures below 100 torr this system should be in the bimolecular regime. A less extended set of measurements was made with 2-methyl-aziridine which does show a small but clear fall-off in k_{inj} . These results can be rationalized in terms of the

regional phase space model, previously proposed for methylnitrite. In systems such as aziridine, where the density of states at the barrier height is sparse ($\approx 10/\text{cm}^{-1}$) the rate of inversion is limited by the relaxation time for intramolecular vibrational energy redistribution. Our results indicate that many nanoseconds are required to attain relaxation, rather than picoseconds, estimated from the Marcus formula for $k_{23}(E) = N^\ddagger(E^\ddagger)/h\rho(E)$. In the methyl-substituted analog the barrier height is approximately 3 kcal mole⁻¹ higher, and the density of states at this barrier is higher than in aziridine. Relaxation data for conformational changes in C₆H₁₂, H₃CONO, SF₄ and C₅H₁₀O were reanalyzed in terms of the regional phase-space model. At low pressures these also show departures from RRKM predictions.

Specific studies, in addition to the two examples cited, were reported in detail in the following publications:

"Intramolecular Unsymmetrical OHO Bonds. Thermochemistry", K. I. Lazaar and S. H. Bauer, J. Phys. Chem., **87**, 2411-xxxx (1983).

"Second Order Rate Constants for Intramolecular Conversions: Applications to Gas-phase NMR Relaxation Times", S. H. Bauer and K. I. Lazaar, J. Chem. Phys., **79**, 2808-xxxx (1983).

Intramolecular Conversion Rates Over Low Barriers. 2. The Alkyl Nitrites", K. I. Lazaar and S. H. Bauer, J. Phys. Chem., **88**, 3052-xxxx (1984).

"Intermolecular Conversion Over Low Barrier. 3. Gas-Phase NMR Studies of an H Bond Association", S. H. Bauer, T. Yamazaki, K. I. Lazaar and N.-S. Chiu, J. Am. Chem. Soc., **107**, 743-xxx (1985).

"Conversions Over Low Barriers. 4. Dimer/Monomer Dissociation in Formic Acid", K. I. Lazaar and S. H. Bauer, J. Am. Chem. Soc., **107**, 3769-xxxx (1985).

"Intramolecular Conversions. V. Rational Rate Constants for Reversible Unimolecular Reactions", S. H. Bauer, Int. J. Chem. Kin., **17**, 367-380 (1985).

"Conversions Over Low Barriers. VI. The cis-trans Isomerization of Monothioformic Acid", K. I. Lazaar and S. H. Bauer, J. Chem. Phys., **83**, 85-xx (1985).

"Intramolecular Conversions Over Low Barriers. VII. The Aziridine Inversion - Intrinsically non-RRKM", D. B. Borchardt and S. H. Bauer, J. Chem. Phys., **85**, 4980-xxxx (1986).

"Resolution of Spectra of Mixtures, Applied to Gaseous Formic Acids", T. Wachs, D. Borchardt and S.H. Bauer, will be published in Spectrochimica Acta A.

"Conversions Over Low Barriers. VIII. The Mechanism & Rate of Dissociation of Dimeric Formic Acid", D. B. Borchardt and S. H. Bauer, submitted to J. Am. Chem. Soc.

END

7-87

DTIC