

NO-A181 426

ATTRIBUTES OF A TACTICAL AIRBORNE RECONNAISSANCE  
COLLECTION MODEL FOR THE AIRLAND RESEARCH MODEL (ALARM)  
(U) NAVAL POSTGRADUATE SCHOOL MONTEREY CA R D HARRIS

1/1

UNCLASSIFIED

MAR 87

F/G 15/4

NL

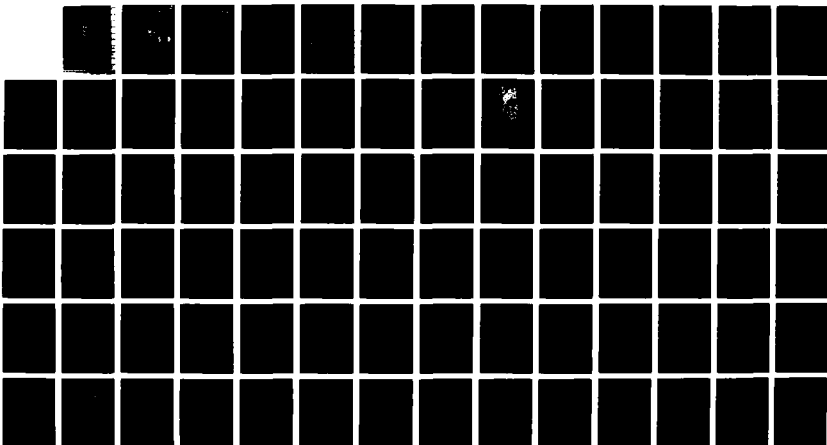

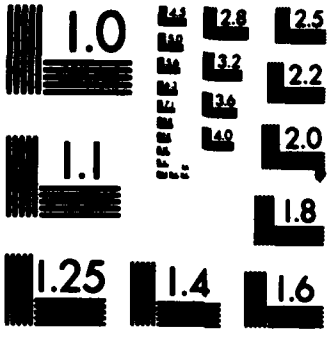

MICROCOPY RESOLUTION TEST CHART  
NATIONAL BUREAU OF STANDARDS-1963-A

2

DTIC FILE COPY

AD-A181 426

# NAVAL POSTGRADUATE SCHOOL Monterey, California

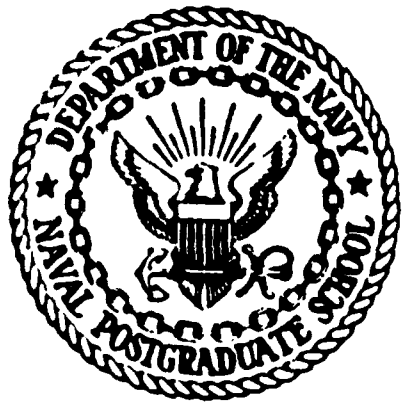

**S** DTIC ELECTE **D**  
JUN 22 1987  
**E**

## THESIS

ATTRIBUTES OF A TACTICAL AIRBORNE  
RECONNAISSANCE COLLECTION MODEL  
FOR THE AIRLAND RESEARCH MODEL (ALARM)

by

Raymond D. Harris, Jr.

March 1987

Thesis Advisor

S. H. Parry

Approved for public release; distribution is unlimited.

REPORT DOCUMENTATION PAGE

1a REPORT SECURITY CLASSIFICATION <b>UNCLASSIFIED</b>		1b RESTRICTIVE MARKINGS <b>A181426</b>	
2a SECURITY CLASSIFICATION AUTHORITY		3 DISTRIBUTION/AVAILABILITY OF REPORT <b>Approved for public release; distribution is unlimited.</b>	
2b DECLASSIFICATION/DOWNGRADING SCHEDULE		5 MONITORING ORGANIZATION REPORT NUMBER(S)	
4 PERFORMING ORGANIZATION REPORT NUMBER(S)		7a NAME OF MONITORING ORGANIZATION <b>Naval Postgraduate School</b>	
5a NAME OF PERFORMING ORGANIZATION <b>Naval Postgraduate School</b>	6b OFFICE SYMBOL (if applicable) <b>55</b>	7b ADDRESS (City, State, and ZIP Code) <b>Monterey, California 93943-5000</b>	
6a ADDRESS (City, State, and ZIP Code) <b>Monterey, California 93943-5000</b>		9 PROCUREMENT INSTRUMENT IDENTIFICATION NUMBER	
8a NAME OF FUNDING/SPONSORING ORGANIZATION	8b OFFICE SYMBOL (if applicable)	10 SOURCE OF FUNDING NUMBERS	
9 ADDRESS (City, State, and ZIP Code)		PROGRAM ELEMENT NO	PROJECT NO
		TASK NO	WORK UNIT ACCESSION NO

11 TITLE (include Security Classification)  
**ATTRIBUTES OF A TACTICAL AIRBORNE RECONNAISSANCE COLLECTION MODEL FOR THE AIRLAND RESEARCH MODEL (ALARM)**

12 PERSONAL AUTHOR(S) <b>Harris, Raymond D., Jr.</b>			
13a TYPE OF REPORT <b>Master's Thesis</b>	13b TIME COVERED FROM <b>TO</b>	14 DATE OF REPORT (Year Month Day) <b>1987 March</b>	15 PAGE COUNT <b>81</b>

16 SUPPLEMENTARY NOTATION

17a COSAC CODES			17b SUBJECT TERMS (Continue on reverse if necessary and identify by block number)
FIELD	GROUP	SUB GROUP	
			<b>Airland Research Model (ALARM), Perception Generation, Perceived Database, Reconnaissance</b>

18 ABSTRACT (Continue on reverse if necessary and identify by block number)

The objective of this thesis is to determine the form of inputs to a reconnaissance information collection module and to state attributes of a perception database generated by the resulting information-seeking activities. This will include descriptive characteristics of collection platforms involved and the subsequent intelligence information flow. Results of this thesis are intended to contribute to the ongoing determination of design specifications for the Airland Research Model (ALARM).

20 DISTRIBUTION/AVAILABILITY OF ABSTRACT <input checked="" type="checkbox"/> UNCLASSIFIED/UNLIMITED <input type="checkbox"/> SAME AS RPT <input type="checkbox"/> DTIC USERS		21 ABSTRACT SECURITY CLASSIFICATION <b>Unclassified</b>	
22a NAME OF RESPONSIBLE INDIVIDUAL <b>Samuel H. Parry</b>		22b TELEPHONE (include Area Code) <b>(408) 646-2779</b>	22c OFFICE SYMBOL <b>Code 55Py</b>

Approved for public release; distribution is unlimited.

Attributes of a Tactical Airborne  
Reconnaissance Collection Model  
for the Airland Research Model (ALARM)

by

Raymond D. Harris, Jr.  
Captain, United States Air Force  
B.A., Alabama State University, 1982

Submitted in partial fulfillment of the  
requirements for the degree of

MASTER OF SCIENCE IN SYSTEM TECHNOLOGY  
(Command, Control and Communications)

from the

NAVAL POSTGRADUATE SCHOOL  
March 1987

Author:

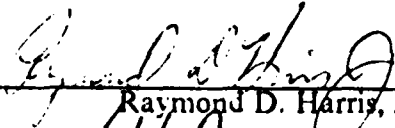

Raymond D. Harris, Jr.

Approved by:

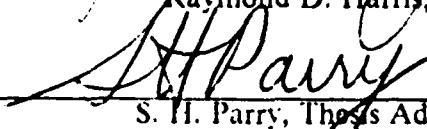

S. H. Parry, Thesis Advisor

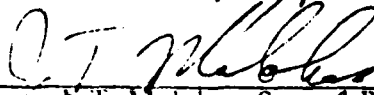

J. T. Malokas, Second Reader

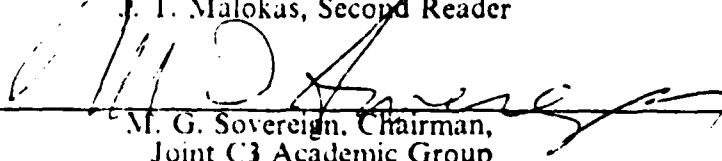

M. G. Sovereign, Chairman,  
Joint C3 Academic Group

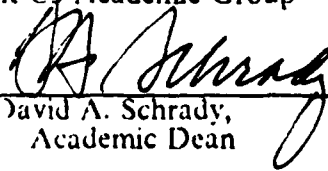

David A. Schrad,  
Academic Dean

# ABSTRACT

The objective of this thesis is to determine the form of inputs to a reconnaissance information collection module and to state attributes of a perception database generated by the resulting information-seeking activities. This will include descriptive characteristics of collection platforms involved and the subsequent intelligence information flow. Results of this thesis are intended to contribute to the ongoing determination of design specifications for the Airland Research Model (ALARM).

<b>Accession For</b>	
NTIS GRA&I	<input checked="" type="checkbox"/>
DTIC TAB	<input type="checkbox"/>
Unannounced	<input type="checkbox"/>
Justification	
By	
Distribution/	
Availability Codes	
Dist	Avail and/or Special
A-1	



## TABLE OF CONTENTS

I.	INTRODUCTION .....	9
	A. GOAL OF THE THESIS .....	9
	B. SCOPE OF THE THESIS WITHIN ALARM .....	11
	C. CHAPTER OVERVIEW .....	12
II.	BACKGROUND .....	14
	A. INTRODUCTION TO ALARM .....	14
	B. MODELLING THE COMBAT DECISION CYCLE .....	14
	1. Time Domain Networks .....	18
	2. Cartesian Space Networks .....	18
	3. The Generalized Value System .....	18
	C. SUMMARY .....	23
III.	GROUND OPERATIONS .....	24
	A. INFORMATION SEARCH WITHIN THE DEEP BATTLE .....	24
	B. THE DEEP STRIKE CONCEPT .....	26
	C. SUMMARY .....	27
IV.	RECONNAISSANCE OPERATIONS .....	28
	A. THE RECONNAISSANCE CYCLE .....	28
	1. Reconnaissance Defined .....	28
	2. The Intelligence Module .....	30
	3. Intelligence Predicting .....	33
	4. The Search Process .....	37
	B. REQUEST FOR RECONNAISSANCE .....	45
	1. Preplanned Requests .....	45
	2. Immediate Requests .....	46
	C. REQUEST COMPONENTS .....	47
	1. Collection Management .....	48

2.	The Scheduled Reconnaissance Mission Timing Plan .....	56
3.	Information Acquisition .....	56
D.	SUMMARY .....	58
V.	PERCEPTION GENERATION EXAMPLE .....	60
A.	SCENARIO .....	60
B.	TIME, $T_0$ .....	62
C.	TIME, $T_3$ .....	66
D.	TIME, $T_{12}$ .....	67
E.	TIME, $T_{13}$ .....	71
F.	SUMMARY .....	71
VI.	SUMMARY .....	72
A.	CONCLUSIONS .....	72
B.	FUTURE DIRECTIONS .....	72
APPENDIX A:	TAR VARIABLES .....	74
1.	ATTRIBUTES THAT ACCOMPANY EACH COLLECTION PLATFORM .....	74
2.	OTHER RADIOMETRIC AND RADAR VARIABLES TO CONSIDER WHEN MODELLING SENSOR- TARGET ACQUISITION .....	74
a.	Radiometric variables required to model the imaging process .....	75
b.	Basic radar variables required to model radar acquisition .....	75
APPENDIX B:	PERCEPTION GENERATION TIMELINE .....	76
LIST OF REFERENCES	.....	77
BIBLIOGRAPHY	.....	78
INITIAL DISTRIBUTION LIST	.....	79

## LIST OF TABLES

1. NODE AND ARC CHARACTERISTICS .....	19
2. BLUE BRIGADE COMPOSITION .....	60
3. PERCEIVED RED FORCE COMPOSITION .....	61
4. SCHEDULED RECONNAISSANCE EVENTS LIST .....	63
5. FEASIBLE COURSES OF ACTION GENERATED AT TIME, $T_{12}$ .....	70
6. MACRO PLAN FOR EVENTS TO BEGIN AT TIME, $T_{16}$ .....	71

## LIST OF FIGURES

1.1	Areas of Emphasis .....	11
2.1	The ALARM Combat Decision Cycle .....	16
2.2	Command Level Structure .....	17
2.3	Network Representation of Terrain .....	20
2.4	Power of an Entity over Time .....	21
3.1	Sections of the Corps Area of Perception .....	25
3.2	Predicted Effects with and without Interdiction .....	27
4.1	Corps Level Information Flow .....	29
4.2	The Intelligence Architecture .....	30
4.3	The Proposed Intelligence Module .....	31
4.4	The Fundamental TAR Request Flow .....	33
4.5	The Expanded TAR Request Flow .....	34
4.6	Simple Network .....	35
4.7	Connected Network .....	36
4.8	Mobility Corridors .....	36
4.9	Visual Representation .....	37
4.10	Relative Motion Coordinates .....	39
4.11	Lateral Range Curve for a Cookie-Cutter Sensor .....	41
4.12	PDET for Non-overlapping Search with $W = 2 \times R_{\max}$ .....	42
4.13	PBAR for an Arbitrary Sensor .....	42
4.14	Typical Lateral Range Curves .....	44
4.15	PDET for Non-overlapping Search with $W < 2 \times R_{\max}$ .....	45
4.16	Determining When to Initiate a Request .....	46
4.17	Collection Management Request Validation .....	49
4.18	Collection Inputs to the Perceived Database .....	50
4.19	Collection Management Request Prioritization .....	52
4.20	Information Acquisition Flow .....	57
5.1	Initial Perceived Situation at time $t_1$ for the commitment of $x_1$ and $x_2$ at $t_{16}$ .....	61

5.2	Power Curves Resulting from an Information Update at $t_0$ .....	62
5.3	Process Flow .....	64
5.4	Process Flow Continued .....	65
5.5	Perceived Situation at time $t_5$ .....	67
5.6	Power Curves Resulting from the Information Update at $t_8$ .....	68
5.7	Perceived Situation at Time, $t_8$ .....	69
5.8	Second Iteration Power Curve resulting from the Information Update at time $t_8$ .....	69
5.9	Third Iteration Power Curve resulting from the Information Update at time $t_8$ .....	70
B.1	Process Timeline with a Decision Period from $t_{16}$ to $t_{24}$ .....	76

## I. INTRODUCTION

### A. GOAL OF THE THESIS

The Naval Postgraduate School (NPS) has maintained a continuing interest in the field of combat modelling and simulations. As part of a research effort initiated at NPS, the AirLand Research Model (ALARM) concept was developed to explore issues concerning the representation of the combat decision process. This particular portion of the model development is concerned with identifying decision logic involved in simulating the direction and application of tactical air reconnaissance (TAR) operations for the purpose of seeing or perceiving the battlefield.

It is generally acknowledged that commanders at all levels base their plans and objectives on their perceptions about their own forces, the environment, and enemy forces. Decisions on how to best allocate resources are then made to attain the prioritized objectives set forth in the plans. Preparation of these combat plans is dependent on the acquisition of information on the condition of the battlefield. In the simulation model this can be viewed as a search for information that is initiated by some type of request. To illustrate, before a brigade can conduct operations to deploy to a predetermined position,  $(x_t, y_t)$ , on the battlefield at time,  $t$ , and prepare to defend that area, plans for the deployment of the brigade must be prepared. The requested intelligence information on the sector of the battlefield containing position  $(x_t, y_t)$ , if timely and accurate, provides the requisite input to prepare plans for the effective direction, control, and employment of the brigade's forces. Thus the intelligence provides necessary information that serves as a foundation to counter enemy decisions and plans. Therefore, it is reasonable to conclude that plans and combat decisions based on timely information concerning the terrain, weather, enemy location, force composition, and activity at some point in time before time,  $t$ , increase the probability of a successful mission. Decisions based on information that is acquired too much sooner or later than time,  $t$ , will probably not reflect the current state of the battlefield and consequently not contribute to effective combat decision making at time  $t$ .

The information upon which perceptions on the state of the battlefield are created and plans formulated in ALARM will be referred to as reconnaissance

information. It is this body of perceived knowledge that, if timely, is indicative of a fundamental combat strategy advocated by renowned military tactician Sun Tzu.

"Know the enemy and know yourself; in a hundred battles you will never be in peril." [Ref. 1: p. 84]

Knowledge is the primary contributor to effective combat decisions. Stated otherwise, success within ALARM is a function of how well reconnaissance information gathering operations are utilized to update the perceived database. In the ideal situation information contained in the perceived database is timely and accurate. However, in capturing the combat process in the model, this may not be the case. Data about enemy forces may not be available and if available, it may be unreliable or outdated. In order to determine attributes of reconnaissance operations required by planning functions contained within ALARM, the following questions should be posed:

1. What is an adequate methodology for predicting enemy intent in order to vector reconnaissance missions over those areas reflecting enemy staging operations?
2. How often should this body of perceived knowledge be updated?
3. What form should the request for reconnaissance information take?
4. How quickly must the information be collected, processed, and fed into the perceived database in order to complete combat plans?

As the perception generation process progresses, data on the current situation is requested, collected, analyzed, and presented to the appropriate command level decision task. These information gathering functions are essentially the basic tactical air information activities of requirements generation, prioritization, and gathering processes that determine perceptions. These perceptions ultimately influence a particular command level decision task's decision on the proportion of air and ground based fire power to be applied toward ground events and the corresponding match of each type to individual targets.

The objective of this thesis, shown in Figure 1.1, is to state the form of inputs to a reconnaissance information collection module and attributes of a perception database generated by the resulting information-seeking activities. This approach will include describing characteristics of airborne collection platforms involved and the subsequent tactical intelligence information flow. Emphasis will not be placed on describing the physical laws and the algorithmic flow involved in modelling mission flight paths, rather in describing inputs to the ALARM planning process and attributes required by the resulting information gathering activities.

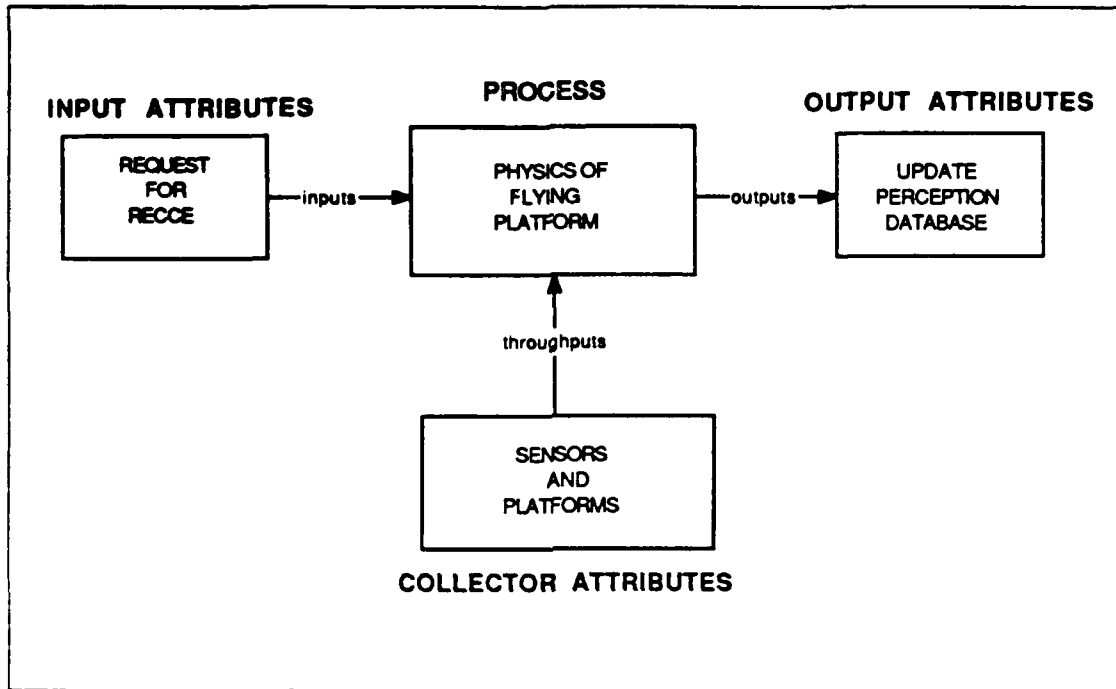

Figure 1.1 Areas of Emphasis.

## B. SCOPE OF THE THESIS WITHIN ALARM

The ALARM concept, though still at the conceptual development stage, was developed to model combat decision processes that occur within the confines of large scale tactical warfare as anticipated by the U.S. Army's airland battle doctrine. The model's proposed highest level of interaction and combat decision making is at the army corps level. This follows because in real world applications the corps is the principle ground force in a theater of operations. Its structure varies based on the operational mission, terrain, and troops assigned. The initial scenario upon which ALARM is cast will be based on the operations of the 5<sup>th</sup> U.S. Army Corps in Central Europe. This scenario was chosen because the NATO area has been one of the primary airland battle areas studied extensively by numerous military analysts. These studies will serve as a baseline to validate output and effectiveness metrics provided by ALARM.

Based on the assumption that enemy forces are echeloned in depth and have numerical superiority, ALARM is envisioned to be used to evaluate an offensive interdiction strategy. This combat strategy requires that friendly forces see deep into

the enemy rear area and strike accordingly to destroy or disrupt enemy follow on echelons before they can be committed at the forward line of own troops (FLOT). This places a requirement on the appropriate command level decision making functions to ensure that adequate surveillance is maintained in order to secure information beyond the corps area of influence. Such information that can conceivably affect success is also depicted as a function of how well perceptions are maintained.

As stated previously, the objective of this thesis is to describe inputs to the perception development process for combat activities occurring at the corps level of interaction. Basically these inputs can be placed into three categories:

1. External conditions, including weather conditions (temperature, air pressure, density and humidity, wind direction and velocity, and cloud cover); terrain (elevation, presence of natural barriers, degree of natural concealment, and characteristics constraining speed of movement); data on terrain illumination; data on roads, bridges, and other structures that may influence the execution of combat operations.
2. Information on the location and condition of the enemy, weapon performance characteristics, and quantity.
3. Information on the position and condition of friendly forces, weapons, and weapon performance characteristics.

In an actual combat situation the process of battlefield perception generation within the corps would undoubtedly be supported by the entire spectrum of intelligence collection and analysis capabilities of the defense department and possibly other NATO agencies. Thus, in reality the corps interfaces with echelons above corps (EAC), national surveillance collection agencies, and more specifically USAF tactical intelligence collection functional organizations to obtain information on enemy units and activities in their respective areas of interest. All of these information-seeking functional inputs are subsets of category 2. ALARM depicts battlefield decisions and operations at the subtheater and tactical level thus, this thesis will not attempt to describe all of the intelligence inputs to the combat decision processes, i.e., inputs from national collection assets. Consequently, the only form of input to perception formulation within the model that will be addressed, given the interaction at the corps level and below, is that derived from tactical air reconnaissance resources.

### **C. CHAPTER OVERVIEW**

During the course of describing attributes for a perception database the thesis will proceed as follows. Chapter II provides a description of the current conceptual design of ALARM, details the planning methodology utilized within the model, and provides the necessary connection to link this work into ALARM's planning scheme.

Chapter III provides background on ground operations and information requirements associated with the airland battle while a description of perception formulation within the corps area of responsibility is provided in Chapter IV. Information gathering entities and flows to include attributes of collection platforms are also identified. Chapter V illustrates the interrelationships between the planning and execution models while describing the evolution of perceptions by walking through a sample scenario. Chapter VI summarizes the research work and offers areas of ALARM requiring additional research.

## **II. BACKGROUND**

### **A. INTRODUCTION TO ALARM**

The term modelling denotes the development of a quantitative representation of some aspect of military combat, the implementation of that representation in the form of a computer program, and the subsequent use of the program to support the analysis of some dimension of military science. One of the most important research areas surrounding military science is the representation of the combat decision process.

Ongoing research on ALARM is directed at exploring ways to model the combat decision cycle. Using the U.S. Army's airland battle doctrine as the combat decision or planning environment, ALARM is intended to provide an analysis tool for the investigation of more optimal methods of planning for and prosecuting the airland battle [Ref. 2: p. 11]. Doctrine for the airland battle emphasizes an integrated battlefield that is singularly characterized by its extended nature. The battlefield is extended with regard to the requirement placed on friendly forces to wage the close-in battle while striking critical high value targets deep within enemy territory.

ALARM will be designed to operate in a systemic mode. This means that the model will have a closed architecture better known as a "no man-in-the-loop" structure. This type of architecture provides the capability to carefully track the cause and effect relationships which are an essential feature of any model of military decision making. The system structure is organized around two separate bodies of models, execution and planning models. Execution models serve to simulate the battlefield conflict while planning models use the information obtained from the execution model to plan for the allocation and commitment of unit entities and resources over time. All plans are based on a particular command level's mission and perceived knowledge of enemy actions over a given time interval.

### **B. MODELLING THE COMBAT DECISION CYCLE**

The term "research model" applies because alternative methodologies are being investigated to examine the combat decision process. Typically, most combat models are cast into an action - reaction mode of simulated operations. They concentrate on the battle execution and react to results generated during execution without regard to projecting battle resource requirements and outcomes of future engagements.

Additionally, in the past, results of planning have been represented only by a set of input data or by human interaction with the model before and during execution [Ref. 3: pp. 1 - 5]. Research on ALARM has been centered on developing a planning procedure that is believed to be closer to what actually happens in the human decision making process.

The planning procedure is a means for assessing the current perceived situation using both a threshold strategy and decision rules. Thresholds will be used to determine when the planning or decision making procedures should be executed while decision rules will be used to limit alternatives. For example, a threshold can be used to determine that a unit is falling behind in its time commitment to advance to a given location. If the unit falls behind by more than two hours, the decision process can be started to determine how and if the delay affects other unit plans. Thus, a threshold starts the decision process. If the effect is significant, the ALARM planning procedure can be reexecuted to counteract or adjust to the delay. A series of decision rules will help eliminate some alternatives available within the decision domain. One of the remaining alternatives is then chosen based on the maximum measure of expected value achieved by alternative. [Ref. 3: p. 11]

From the data analyst's perspective these planning models are important for representing what and why things happen, i.e., to produce the desired detailed audit trails.

A high level view of the combat decision cycle is shown in Figure 2.1. To illustrate the process, the planning model (1) accepts an initial data input and creates a set of orders (2) that is entered into the execution model (3). Orders are a series of times and missions input to each command level subordinate to the corps. The command level structure embedded within the planning model is shown in Figure 2.2. Orders passed to each command level are composed of the following information:

1. A sequence of times,  $t_i$
2. A mission during  $t_i$  to  $t_{i+1}$
3. Sector boundaries during  $t_i$  to  $t_{i+1}$
4. Desired FLOT trace at time  $t_{i+1}$
5. Minimum friendly unit state at time  $t_{i+1}$ , i.e., an acceptable friendly force attrition level.
6. Maximum enemy unit state at  $t_{i+1}$ , i.e., a required amount of attrition to the enemy force for a given mission. [Ref. 3: pp. 32 - 51]

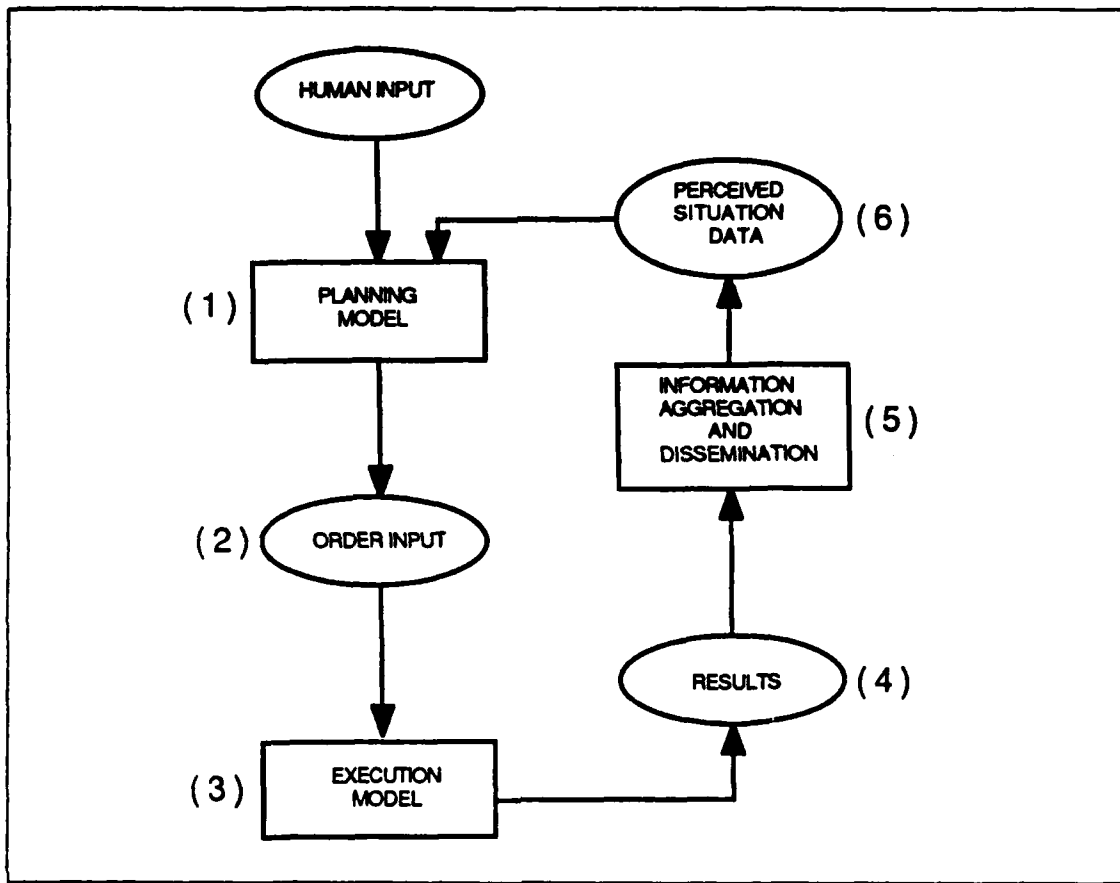

Figure 2.1 The ALARM Combat Decision Cycle.

This "what to do" type of guidance is referred to as macro planning. Macro plans are closely tied to the perceived knowledge of friendly and enemy unit strength at time,  $t_{i-1}$ . A projection of the relative state variables and unit strengths is performed in order to determine how to maximize combat effectiveness by allocating only the required number of assets at a future time,  $t_i$ , toward the perceived most advantageous enemy targets. This "how to do it" information is then passed to the execution model and the results (4) of the force-on-force engagement planned for by the planning model are produced. If at any time during execution the original plan for the commitment of forces reaches a point of infeasibility due to the attainment of an upper threshold of friendly units neutralized, then planning is reinstated to hopefully formulate a plan that will cause the evolution of a favorable battlefield situation. Next, the combat results are passed through an information program (5), delayed, and filtered until the

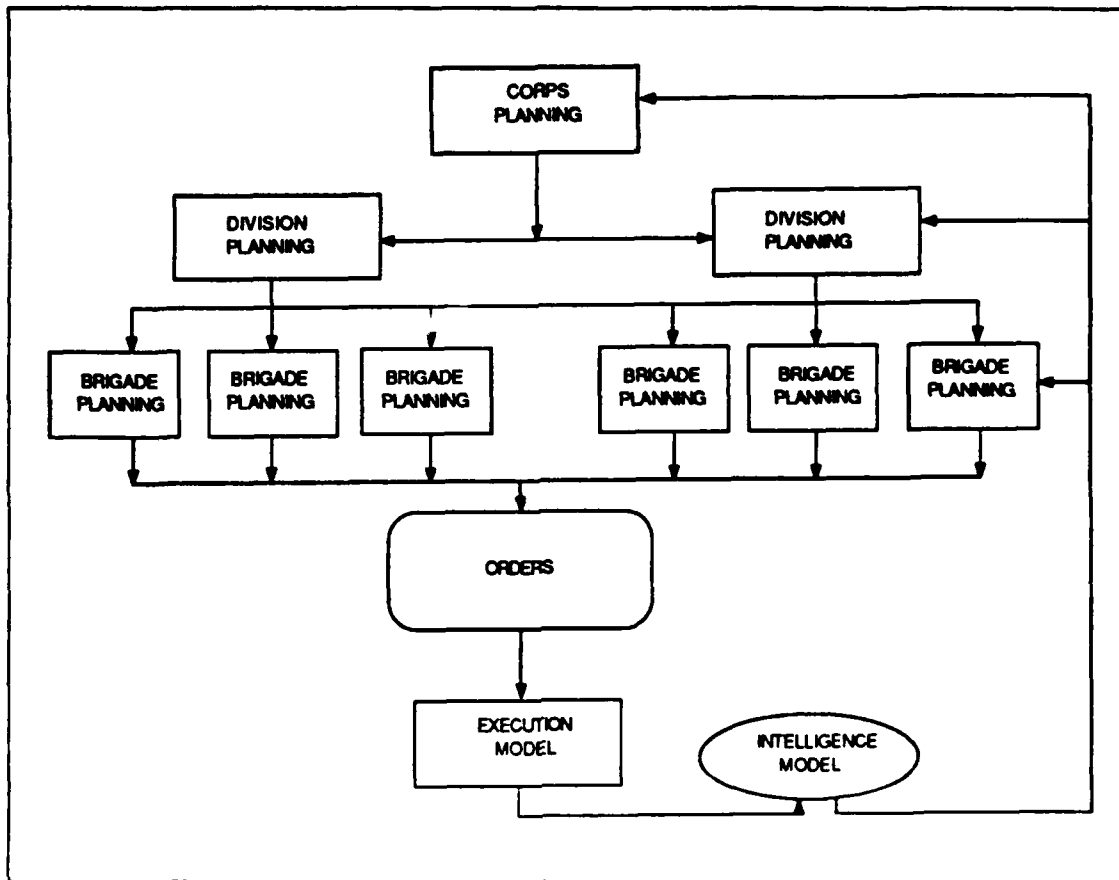

Figure 2.2 Command Level Structure.

perceived state of the battlefield (6) is reentered into the planning model. At this point new or modified orders are created [Ref. 2: pp. 30 - 45]. The role of reconnaissance operations is to keep the perceived state of the force on force engagement and surrounding battlefield areas current so that when decisions (plans) must be formulated, the planning model can be invoked using current information as a solid foundation. This proposed architecture will provide indepth audit trails through the use of three unique methodologies that make ALARM different than any other current research to date [Ref. 3: p. 11]. These methodologies are

1. Time Domain Networks,
2. Cartesian Space Networks, and
3. The Generalized Value System.

### **1. Time Domain Networks**

The time domain network is designed to handle the planning activities within ALARM. The network consists of nodes and arcs typical of most networks. The significant feature of the time domain network is that the arcs represent the passage of time rather than distance and is used in order to develop high level mission requirements for all subordinate units. Functionally, it resembles a program evaluation and review technique (PERT) network in that all sub-activities that flow out of a starting node can not begin until all sub-activities that lead into the starting node have been completed. Two sets of parameters determine input constraints to the network: immutable factors and changeable factors. Immutable factors include items such as weather and enemy forces. They are essentially those elements that a commander has no control over. Changeable factors, also referred to as decision factors, are parameters for which a decision is needed. For example, a decision factor might be to determine the percentage of some available resource to be committed to an activity. [Ref. 3: pp. 12 - 16]

### **2. Cartesian Space Networks**

In ALARM, transportation networks are used to represent terrain features and physical connections between points in the battlefield area. These interconnected sets of arcs and nodes contain attributes which describe the terrain, roads, and cities as well as on and off-road trafficability. Characteristics of arcs and nodes are provided in Table 1 while the network representation of a geographical region is shown in Figure 2.3.

### **3. The Generalized Value System**

The key feature of the planning model is its ability to determine the perceived power of battlefield entities. A procedure known as the Generalized Value System (GVS) is used to accomplish this task. The GVS is a means by which the perceived combat power of battlefield entities is measured over time, relative to when the entities are in position to accomplish their stated missions. Two types of power are defined: derived and inherent [Ref. 4]. The total power possessed by a given entity, measured in units of STAPOWS (standard power), is the sum of its inherent and derived power. Some entities may possess either derived or inherent power while others may have both.

Derived power of an entity results from the ability of that entity to change or maintain the inherent power of other entities. Examples of entities holding derived power are bridges, intelligence units, and supply units [Ref. 5: p. 31].

TABLE I  
NODE AND ARC CHARACTERISTICS

<i>Node Characteristics</i>	<i>Arc Characteristics</i>
$N_i$ ; node id number	$H_j$ ; head node id number
$NV_i$ ; latitudinal coordinate	$T_j$ ; tail node id number
$NH_i$ ; longitudinal coordinate	$D_j$ ; arc length
	$RC_j$ ; route class type
	$OC_j$ ; terrain trafficability
	$W_j$ ; route width

An entity possesses inherent power when it has the capacity to disrupt, delay, or destroy enemy forces. In this context, inherent power can be viewed as the combat power that entities are able to use against enemy forces. Inherent power is subdivided into three components; basic, adjusted basic, and situational. Basic inherent power (BIP) is the power possessed by an entity when it is positioned to engage an adversarial entity. Adjusted basic inherent power (ABIP) is defined as the BIP of an entity that is adjusted for each entity's mission and current state. Another factor that is used to calculate the ABIP is the the distance from the position where the unit is to accomplish its mission. Situational inherent power (SIP) is the inherent power an entity is projected to possess at some time in the future based on the most current information on the entity. The procedure to project power is based on the assumption that combat power increases exponentially, relative to time, when not affected by attrition as the entity draws closer to reaching a position to achieve its planned objective.

*a. Measuring Power*

The inherent power of an entity can be determined by relating the components of power to the entity's known mission. Upon attaining position to accomplish its mission, the SIP for each entity is recalculated to account for the consumption of resources and attrition caused by an engagement with an enemy entity. This power is also assumed to decay exponentially over time. [Refs. 4,5] provide the mathematical derivation along with a rigorous explanation of how to calculate these

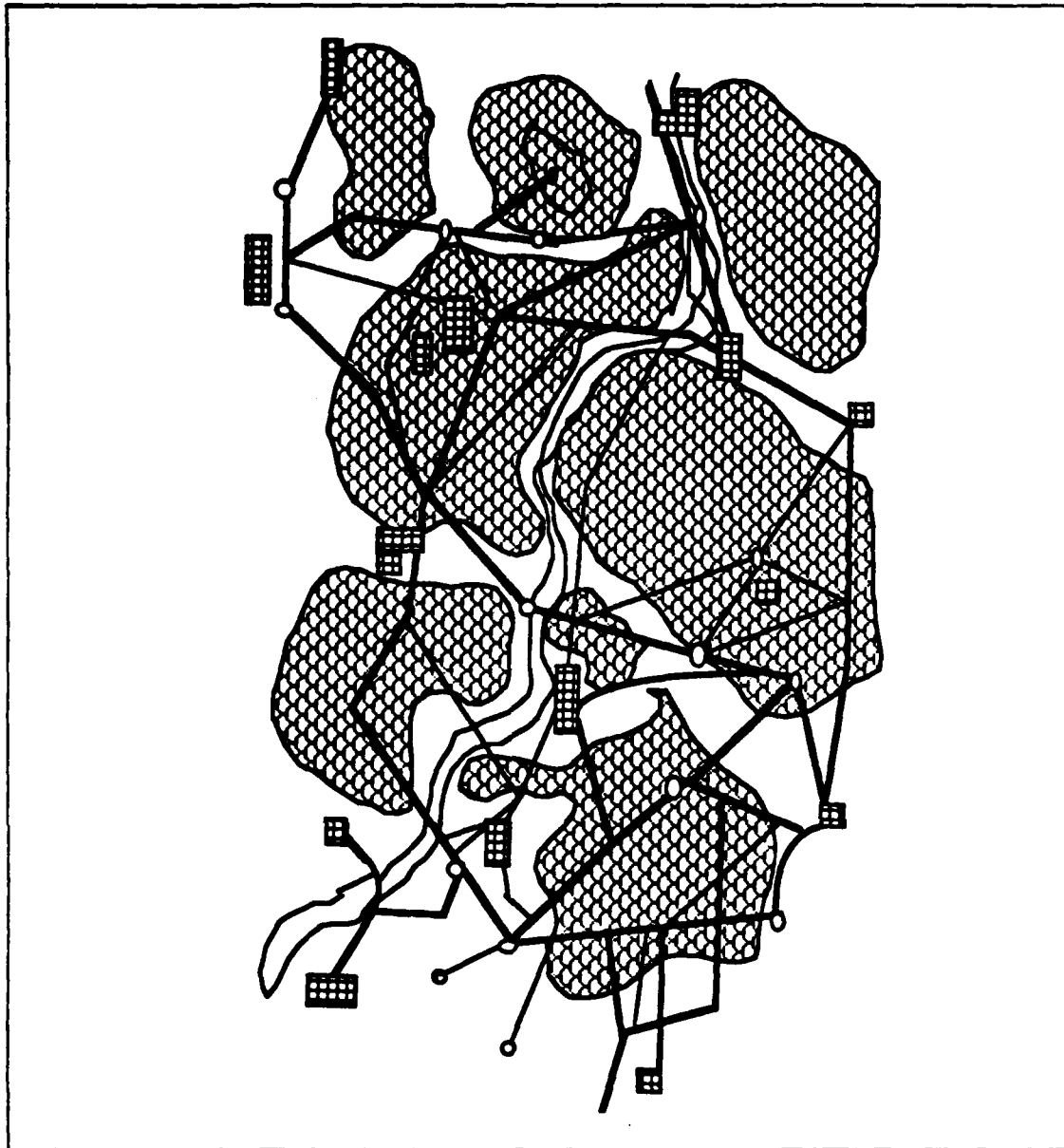

Figure 2.3 Network Representation of Terrain.

power values. A graphical illustration of the evolution of the situational inherent power of an entity is provided in Figure 2.4.

## SITUATIONAL INHERENT POWER for $X_t$

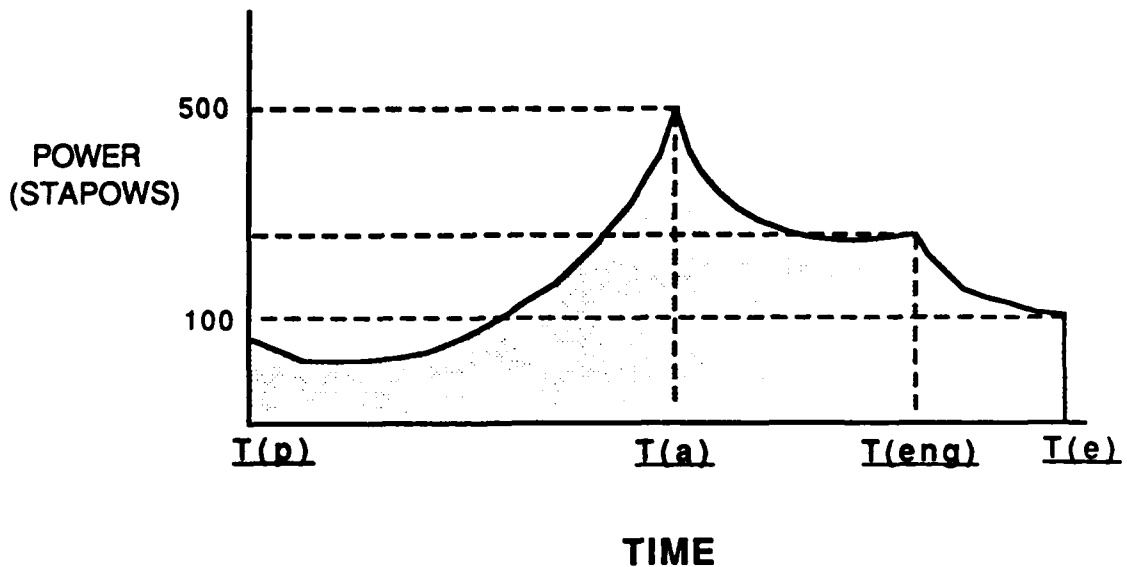

Figure 2.4 Power of an Entity over Time.

### *b. Use of GVS to Determine Mission Feasibility*

The planning<sup>1</sup> process begins with a mission, friendly troop list, and a specified decision period received from a higher command level. The mission states the command level's operational objective while the friendly troop list refers to the assets available to accomplish a mission. The decision period is the amount of simulated real time allotted to complete the assigned mission.

Assuming a mission to engage at the FEBA (forward edge of the battle area), intelligence is obtained consisting of information on the perceived disposition of enemy forces. This information is used to determine if the assigned mission to engage enemy forces with the current assets allocated is feasible. The feasibility check is performed based on comparisons between known blue force power and perceived red force power. Each force's power is computed as the sum of the powers of subordinate entities within a specified sector that have an assigned mission in that given sector. The summation is taken from the beginning,  $t_p$ , to the end of a decision period,  $t_c$ , to

<sup>1</sup>Note that this is only a "plan of attack". Stochastic events occurring in the execution model along with the actual state (ground truth) of red forces may cause the macro plan to fail. Therefore, in the process of plan formulation, it is clear why accurate perceptions must be maintained on the current state of the battlefield.

produce SIP functions for the powers of each force. Power thresholds are then associated with corresponding differences between blue and red force power projections. To exceed an upper threshold indicates that a force too large has been committed while a lower threshold violation represents a difference that suggests an undercommitment of forces. In the process, uncommitted units are time phased in discrete time intervals, through the decision period. Corresponding SIP functions are generated by then committing these units against their most likely adversary. This methodology forms the basis for determining mission feasibility for the duration of a decision period. If time stepping through the decision period without counting the contribution of the uncommitted forces does not cause a threshold violation, then only the originally committed FEBA forces are perceived needed to maintain a favorable power differential in that sector. The occurrence of a point of infeasibility indicates a flag in the simulation clock process time that a decision must be made to commit additional resources to maintain a favorable SIP differential. This event time is referred to as the decision point,  $t_d$ . The decision point serves as the base simulation event time for determining when the blue forces need to have affected the power of red forces predicted against them. This assumes that the red force plan remains constant throughout the planning process. Next, the planning model is invoked and a new plan is developed based on the most recent red plan of battle using intelligence received prior to the decision time,  $t_d$  [Ref. 5: pp. 44 - 46]. The decision point not only indicates the magnitude of power in which Red power must be decreased, but also provides the simulation time in which the blue force must allocate<sup>2</sup> those assets to maintain plan feasibility.

Developing feasible alternatives is a process of generating several blue asset<sub>i</sub> to red target<sub>j</sub> pairs and projecting new SIP functions for each pairing. The alternative which demonstrates the largest ratio of red power neutralized to blue power utilized is then selected. Red power destroyed is measured as the difference in power at the decision point between the original red force SIP and the SIP reflected in the pairing process. Blue power used is determined by the difference between the SIP of an uncommitted entity at the decision point and the SIP derived after the pairing using perceived attrition rates.

---

<sup>2</sup>Allocation is the process of formulating alternatives to determine which asset(s) to use in order to restore macro plan feasibility.

### C. SUMMARY

ALARM is a combat model undergoing development that utilizes three unique methodologies to represent combat interactions and the combat decision cycle. The three methodologies are time domain networks, cartesian space networks, and the generalized value system. The time domain network represents the subactivities that must be accomplished for a unit to complete a mission. Cartesian space networks represent physical connections between points on the battlefield. The generalized value system is a procedure for quantifying the importance of entities on the battlefield at some future time.

In terms of maximizing the effectiveness of combat operations, significant issues to be addressed by analysis of the results provided by ALARM are:

- The development of modelling methodology appropriate for the large-scale but sparsely populated rear areas involved in the interdiction battle and for the command and control of the airland battle force.
- The application of these methodologies in the construction of a simulation wargaming model.
- Eventual use of the model to perform research on the conduct of the total airland battle. [Ref. 2: p. 2]

As stated earlier, battlefield perceptions form the basis for all power projections in the model. The need for information on battlefield deep areas to shape these perceptions is the topic of the next chapter.

### **III. GROUND OPERATIONS**

#### **A. INFORMATION SEARCH WITHIN THE DEEP BATTLE**

Information on the condition of the battlefield must be obtained so that power projections can be made. Before describing the process used to obtain and formulate battlefield perceptions, the environment in which corps operations take place must first be examined.

The Corps is responsible for combat activity conducted in an area of perception (see Figure 3.1). The area of perception is the area within which the corps must sense and keep aware of the activity and movement of enemy forces. This geographical region is subdivided into two smaller areas, influence and interest. The area of influence is that portion of the battlefield in which the commander can directly affect the course of the battle by using assets organic to the corps or assets controlled by subordinate units. Enemy entities (i.e. tanks, artillery, etc.) exist within the area of influence and are in position to affect blue force combat mission objectives within 72 hours. The area of influence is a subset of the area of interest. The area of interest is that portion of the battlefield where friendly forces do not possess the capability to directly influence the battle using organic assets. This area extends beyond those regions in which enemy units or battlefield conditions are capable of affecting a blue unit's mission in the near future. The time horizon associated with the area of interest is approximately 96 hours. Information acquired therein allows the simulated planning time necessary to make decisions with respect to the proper allocation of assets to the full range of the area of influence.

Normally the corps does not possess the capability to adequately monitor enemy activity occurring within the area of interest. It is of paramount importance that the corps receive information on enemy operations while enemy follow-on echelon targets are deep within enemy territory. Information concerning the area of interest is received primarily from higher or adjacent command levels. In the model, tactical air reconnaissance (TAR) assets will support the corps' need for information on battlefield deep areas.

In ALARM each command level is dependent on accurate information on the perceived state of the enemy targets. The resulting battlefield information concerning

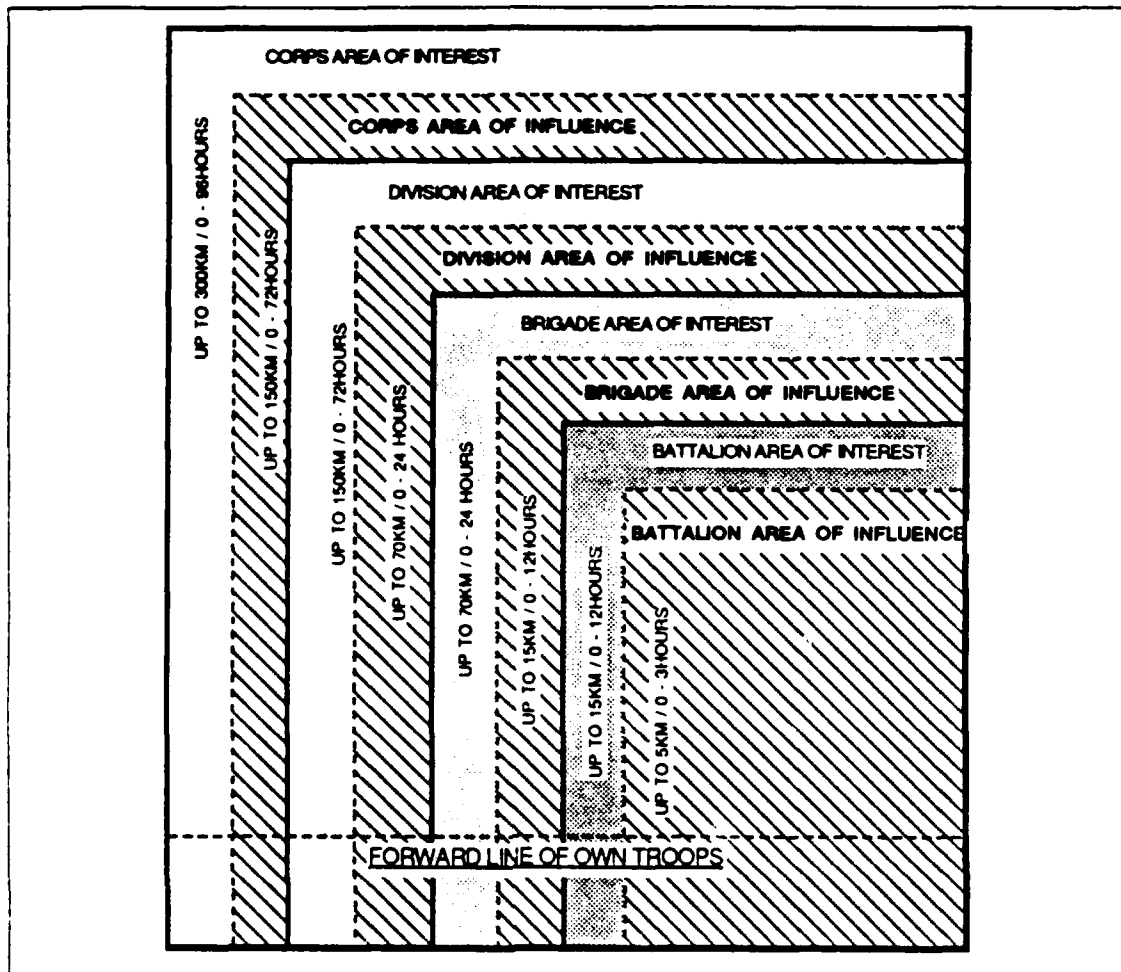

Figure 3.1 Sections of the Corps Area of Perception.

the inherent power possessed by enemy entities at time,  $t_0$ , serves as a base power estimate. It permits the projection of the enemy's strength at some time,  $t_i$ , in the future. These estimates are essential in the development of plans to, for example, either offset the enemy by an additional allocation of assets at the predicted time of engagement,  $t_{eng}$ , or possibly through the employment of forces to decrease the enemy's projected inherent power through interdiction operations at some time prior to  $t_{eng}$ .

## B. THE DEEP STRIKE CONCEPT

Airland battle operations which employ the deep battle concept require timely information to acquire and prioritize prosecution of enemy high value targets. According to U.S. Army Field Manual (FM) 34-1, the deep battle is focused on directing well planned strikes against second echelon forces while conducting close-in operations. Actions taken against second echelon forces are an attempt to delay, disrupt, or destroy enemy forces before they can be brought to bear in the close battle. Former Commander in Chief of the U.S. Readiness Command, U.S. Army Gen. (ret) Donn Starry states,

The need for deep attack emerges from the nature of our potential enemies -- their doctrine and their numerically superior forces. What is important is that superiority in numbers permit him to keep a significant portion of his force out of the fight with freedom to commit it either to overwhelm or to bypass the friendly force. If the battle is fought with no directed interdiction then enemy follow on echelons have a free ride until they enter the close in battle. The enemy retains flexibility, initiative, and momentum to apply his mass at a point and time of his choice. Deep attacks serve to deny him of this freedom. [Ref. 6: p. 42]

Thus, interdiction operations are required at the very least to slow down follow-on echelons thereby allowing for an aggressive defense to repel enemy frontal assault echelons.

Without interdiction (see Figure 3.2) the enemy is able to maintain consistent superiority at the FLOT over time [Ref. 6: p. 43 - 46]. During this period the defender's strength dwindles and the enemy's freedom of action increases. Conversely, properly placed interdiction allows friendly forces to hold off enemy follow on echelons. This creates periods of friendly superiority called windows of opportunity. When these windows appear, friendly forces obtain a greater chance of victory based on the assumption that friendly forces have identified critical high value targets and are prepared to act on time.

Within ALARM a command level decision task's planning horizon is a function of the depth to which it can see beyond the FLOT. This is a direct consequence of how well friendly information seeking or reconnaissance operations can locate enemy targets. Such target nodes, in the model, may include fixed bridges or mobile sites whose destruction may slow the rate of advance of enemy entities and cause follow on echelons to bunch up thereby presenting themselves as attractive targets. Attacking these and other high value targets will delay the enemy's "free ride" to the FLOT and

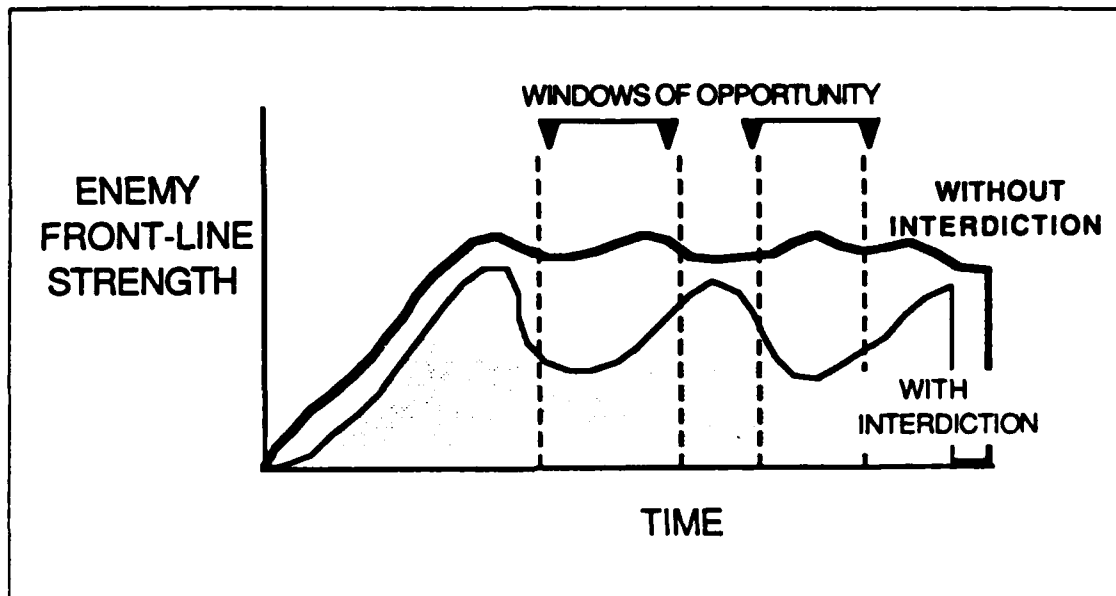

Figure 3.2 Predicted Effects with and without Interdiction.

provide friendly force entities requisite time to finish the close-in battle. To summarize, the goal of the deep attack is to create opportunities for friendly forces to take action on regions well forward in the battle area [Ref. 6: p. 46]. This can only be accomplished by concentrating information acquisition resources to reveal critical targets which offer the highest potential payoff in upsetting enemy plans.

### C. SUMMARY

The corps is responsible for conducting military operations using organic assets within a geographical region known as the area of influence. However, information must be obtained from within the areas of influence and interest to expand the corps' planning horizon. The resulting corps planning may emphasize a "deep strike" in order to delay the enemy's free ride to the FLOT. Reconnaissance operations will provide the means, in the model, to initially acquire these high value targets in the corps area of interest. Accurate portrayal of the prioritization of targeted areas and components of a perceived database are the main focus of discussion in the next chapter.

## IV. RECONNAISSANCE OPERATIONS

### A. THE RECONNAISSANCE CYCLE

The prime objective of tactical air reconnaissance activities is to provide information necessary to maintain accurate battlefield perceptions. This chapter depicts the process in ALARM that provides information which organic ground force collection entities may not be able to obtain and describes attributes of airborne reconnaissance functions. These essential elements of information obtained through coordinated collection efforts contribute to the need to stop the simulated forward surge of enemy forces by providing details to each command level decision task. The information supplied is relative to a particular level's area of interest and serves to determine:

- the network locations of the placement of enemy lines of communication, installations, and electronic emissions;
- the disposition, composition, and movement of enemy forces;
- post strike damage;
- conditions in the surface battle areas; and
- weather and terrain. [Ref. 7: pp. 2 - 18]

To successfully defeat the opposing forces, each command level must recognize enemy intentions and make the appropriate resource allocation decisions to seize the initiative at the earliest and most opportune times of simulated battlefield activities. The act of seeing actual and potential battlefield events occurring on the terrain network forms the basis for perceiving enemy intentions so that macro plans can be developed.

#### 1. Reconnaissance Defined

With regard to the simulation model, reconnaissance is defined as any collection mission undertaken to obtain by visual or other detection methods, information about the activity of the enemy. This includes one time coverage of specific target areas (i.e. nodes) and the systematic coverage of broader areas (i.e. arcs) over an extended period of time to note changes that take place. Reconnaissance missions conducting surveillance operations collect information continuously from airborne platforms while strictly reconnaissance operations are directed toward localized target nodes. In the model, TAR missions include sensor coverage of all

phases of enemy operations not supported by collection assets organic to the corps or command levels subordinate to the corps decision level. Before depicting the flow of information acquired by TAR collection assets, the general flow of information within the corps level decision task will be reviewed.

Figure 4.1 is a simplified diagram of the information flow into the corps level. Information (7), defined as unevaluated material obtained through the application of

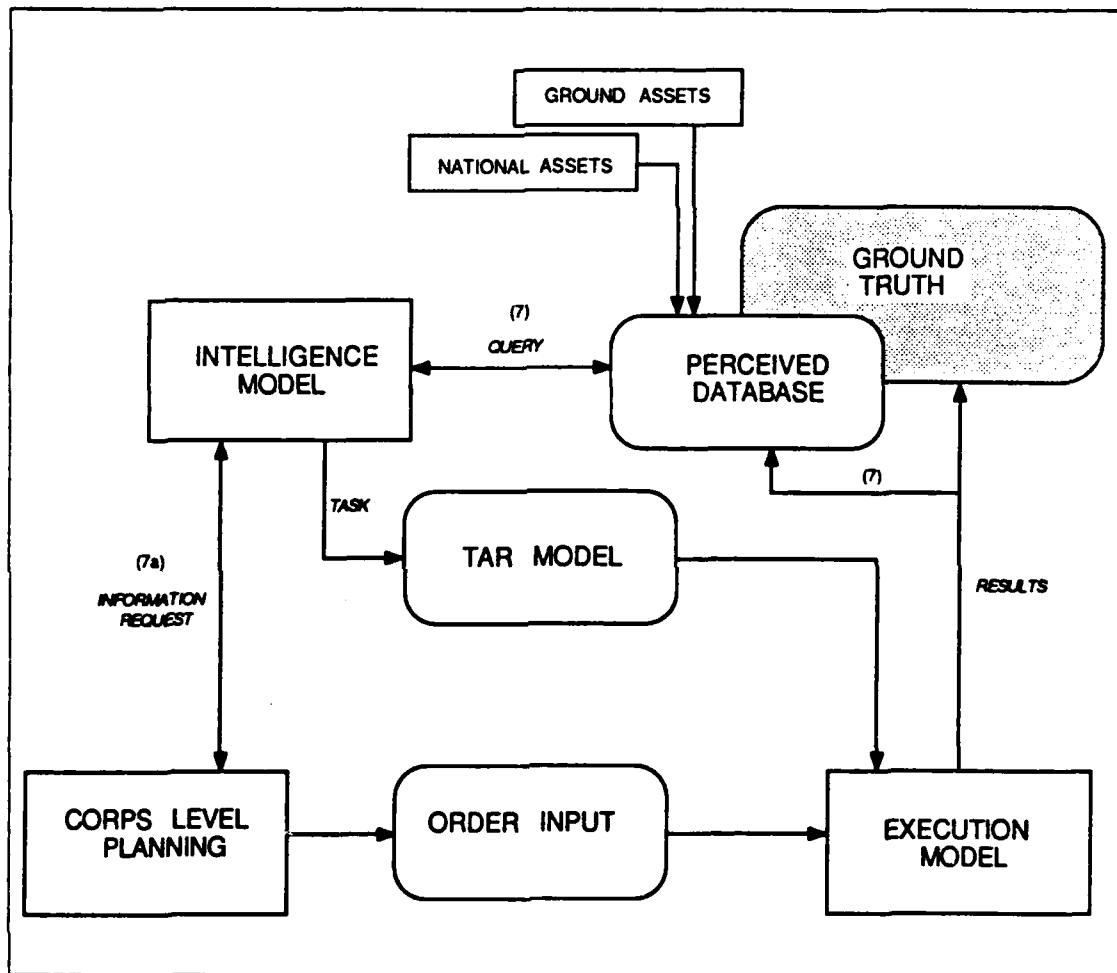

Figure 4.1 Corps Level Information Flow.

collection efforts, flows into the intelligence function. This information is screened, formatted, and forwarded to corps level planning (7a) when the need arises. It is assumed that organic corps collection assets provide information primarily on the corps' area of influence while TAR collection can obtain information within the area of

interest. Information provided by TAR assets strictly within the area of influence can be viewed as a function of nonavailability of organic corps collection assets. Turning now to Figure 4.2 [Ref. 8: p. 24], the intelligence functional architecture analyzes the collected information, makes the necessary source level checks at each decision level, and identifies combat information. Combat information consists of that information which is readily exploitable, filtered, and passed between command level decision tasks.

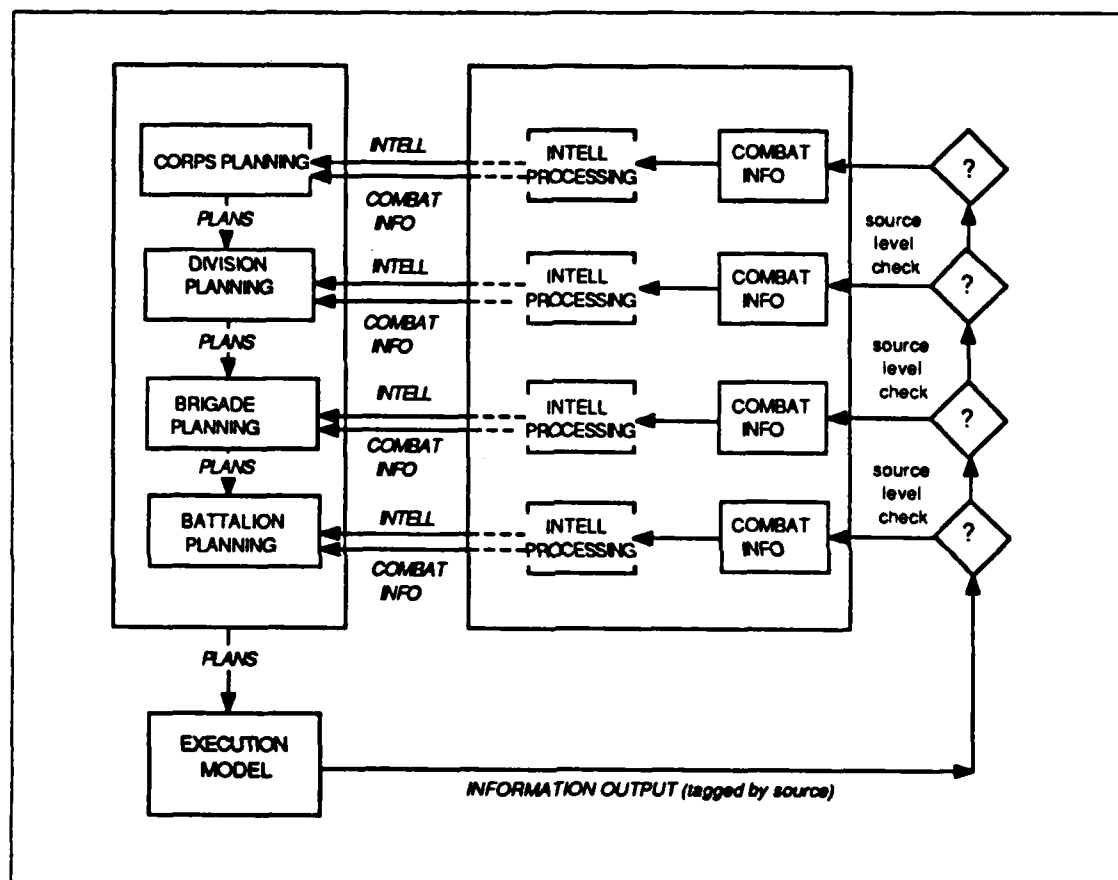

Figure 4.2 The Intelligence Architecture.

## 2. The Intelligence Module

The proposed intelligence module, developed by NPS graduate Gaylon Smith [Ref. 8], consists of two components for each command level; a combat information processor (CIP) and an intelligence estimate processor (IEP). Information generated from within the execution model is identified by the collector and flows upward

through the hierarchical network to the appropriate CIP (see Figure 4.3). The CIP updates the perceived database and directs the combat information to other task force

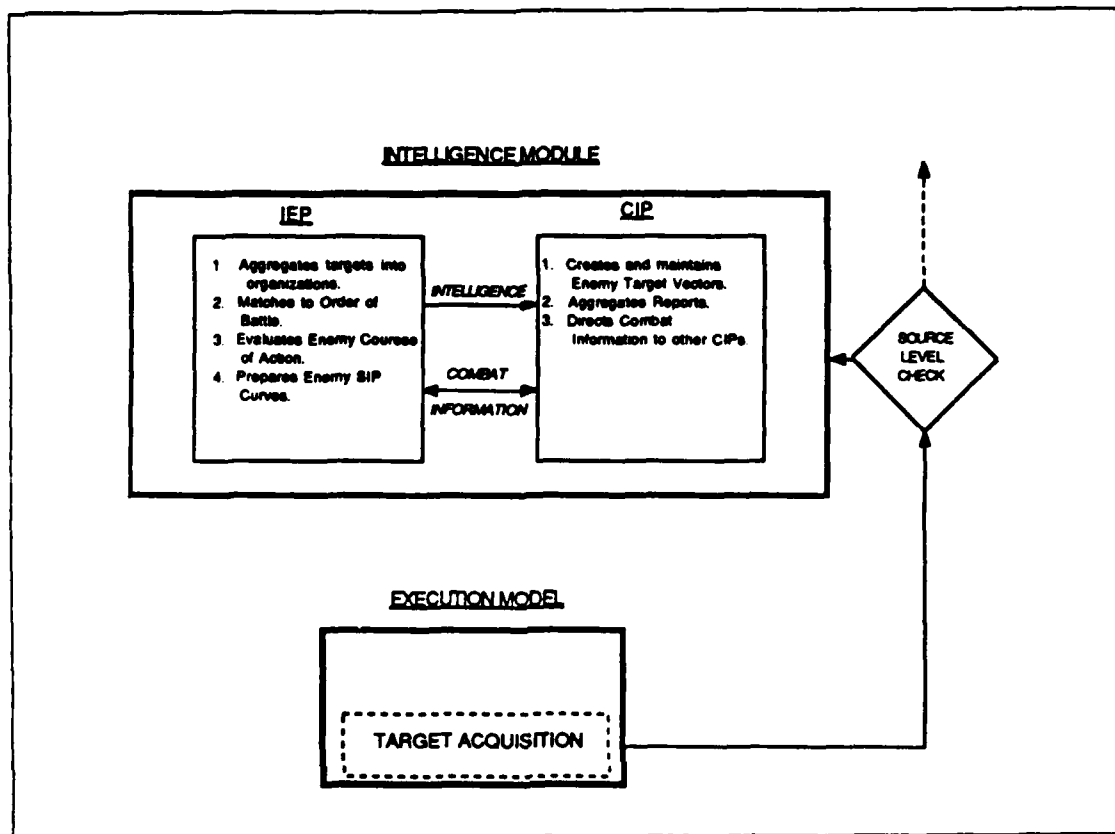

Figure 4.3 The Proposed Intelligence Module.

elements as required. The purpose of the IEP is to prepare an intelligence estimate which identifies enemy units, their locations with associated nodal positions, and perceived courses of action in order to task reconnaissance assets. The IEP also develops the SIP curves for the enemy units used by the planning model to determine asset allocation and mission feasibility.

The motivation for describing the proposed intelligence module is to explain why all requests for TAR will enter the system from the corps decision task level. In reality, an air request net (ARN) links each command echelon. The ARN is used primarily by ground commanders to request immediate support for ground forces and is monitored by all echelons above battalion. To illustrate, assume a battalion is in need of reconnaissance over a specific point within its area of influence. Additionally,

the information is required before some critical time,  $t_c$ . If collection assets organic to the battalion are unavailable then brigade collection assets would respond to the information<sup>3</sup> requirement. If all organic ground force collection assets were unable to respond to the request or unavailable through the corps level then the information requirement would be submitted from the corps level to the USAF intelligence collection functional organizations within the Tactical Air Control System (TACS)<sup>4</sup> for satisfaction. Each request would then be satisfied by reconnaissance operations generated within the TACS depending on the availability of collection assets, the priority, and timing requirements set forth in the request. Thus, using this abstraction from reality, all requests for TAR in the model will flow from the corps level. The basic flow of a TAR request is shown in Figure 4.4.

An expanded view of the entire TAR request cycle is shown in Figure 4.5. The procedure is initiated by corps planning (8) due to the necessity to acquire information on deep zones. The planning procedure described in chapter 2 is then carried out in (9) to generate a macro plan. If planning is complete (i.e. the mission is determined feasible) then orders are passed to subordinate units or entered into the execution model. If planning is not complete then information must be obtained from the perceived database (14) to consummate the plans. Example items of real world information primitives required in the perception database are:

- a. Which enemy airfields (nodes) are perceived most capable of performing strikes against friendly forces?
- b. What terrain locations (nodes or arcs) are the most threatening elements massing?
- c. Which and where are prime and secondary target nodes to inhibit enemy movement?
- d. What is the disposition of enemy second echelon forces?

These information requirements are levied on the intelligence function (10) and must be satisfied before each battle execution begins. Assuming the information contained in the perception database does not satisfy the information requirements (11) or does not meet timing constraints due to the projected timing of the mission, then information gathering activities are initiated (12). First the availability of organic assets is assessed to determine if they can meet timing constraints or if they are

---

<sup>3</sup>Upper command levels intelligence functions support the information requirements of subordinate levels.

<sup>4</sup>The Tactical Air Control System is the C<sup>2</sup> system developed to support the air component commander to effectively employ air power.

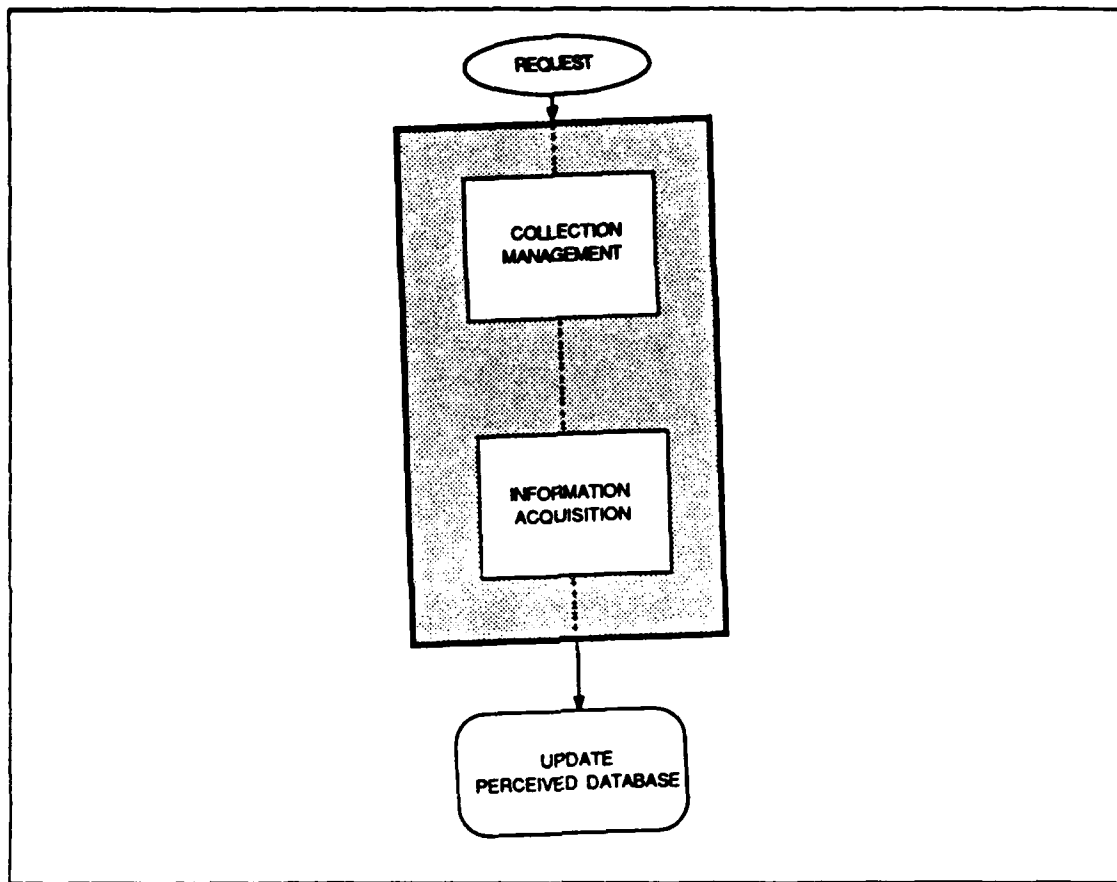

Figure 4.4 The Fundamental TAR Request Flow.

functionally capable of performing the requested collection task. If these organic corps assets are unable to respond to the information request then TAR assets are tasked (13).

### 3. Intelligence Predicting

The IEP [Ref. 8: pp. 25 - 26] operates on the perceived database at the corps level to prepare an intelligence estimate, identify enemy unit entities, and predict their courses of action. These estimates are based on the currency of the perceived database. Due to the dynamic battlefield situation produced by results from the execution model, SIP curves developed within the IEP may not accurately reflect the current power of enemy units. Thus, reconnaissance information is recognized to be highly perishable. Once the time of collection for a given sector of the battle area has become dated, by violation of a predetermined perception timing threshold, then

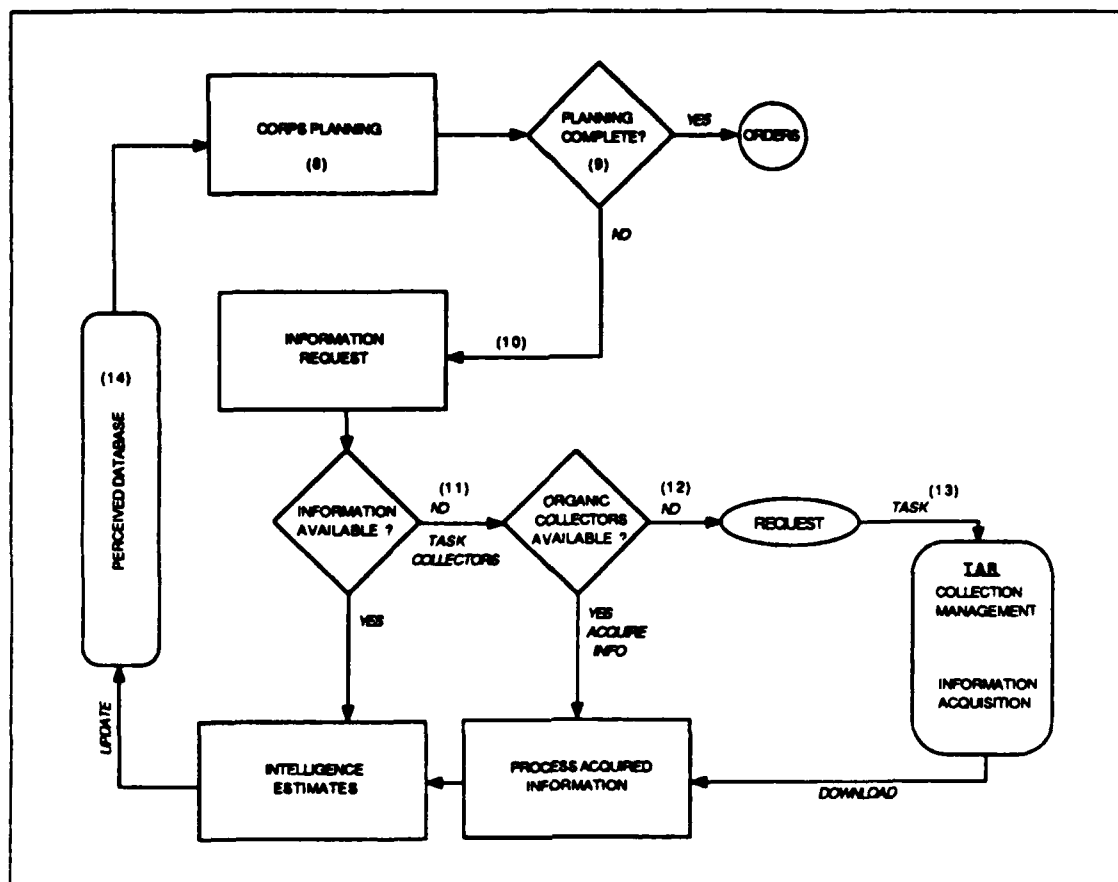

Figure 4.5 The Expanded TAR Request Flow.

reconnaissance operations are initiated in order to maintain a required level of perception accuracy.

Estimation, performed by the IEP, of the area to be reconnoitered may be determined by predicting enemy avenues of approach coupled with the evaluation of stochastic meteorological conditions along mobility corridors [Ref. 5]. A procedure developed by another NPS graduate, Doug Fletcher, utilizes the terrain network to determine enemy expected avenues of approach. Fletcher defines avenues of approach as routes and zones of action as corridors along which enemy forces are expected to transit. The zones are determined by the size of a particular unit attempting to pass. The procedure is conducted by taking a network (see Figure 4.6) and determining feasible routes. Feasibility refers to the flow capacity of each arc which can support doctrinal rates of advance for maneuver elements. Using a battalion rate of advance

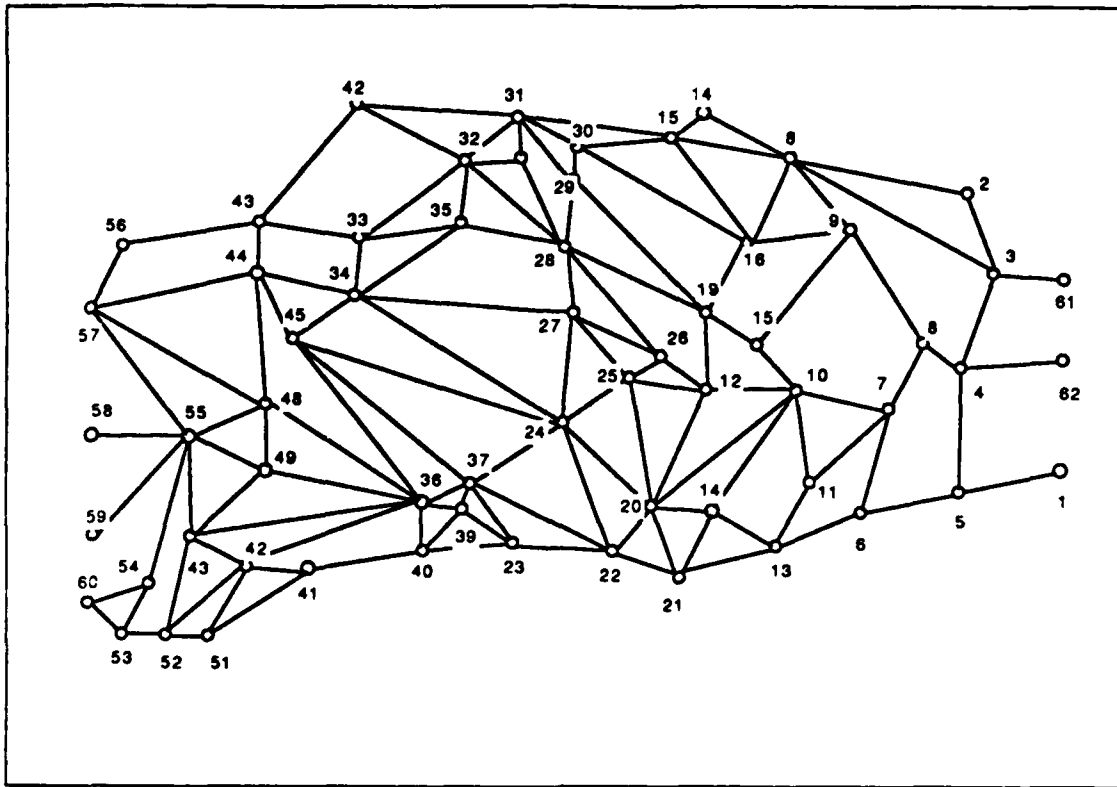

Figure 4.6 Simple Network.

for illustrative purposes, the resulting connected network, shown in Figure 4.7, is formed.

Arcs on the transportation network are used in the battalion planning process. Zones consist of those arcs that can accommodate the sized units that the battalion is concerned about, i.e. its own companies and enemy regiments. These arcs are aggregated yet do not represent a single physical road from point A to B, but in fact may be a series of roads or open valleys that comprise a regimental avenue of approach [Ref. 3: p. 20]. Nodes on the network are then grouped in the zones in order to aggregate flow rates. Next, horizontal corridors are formed. It is within these mobility corridors that areas requiring TAR activity are emphasized (see Figure 4.8). The information obtained from within these areas may serve to confirm or deny an enemy course of action.

Assuming that corps level organic collectors are unavailable, then a request is submitted to the TAR model to obtain information from within the mobility corridors.

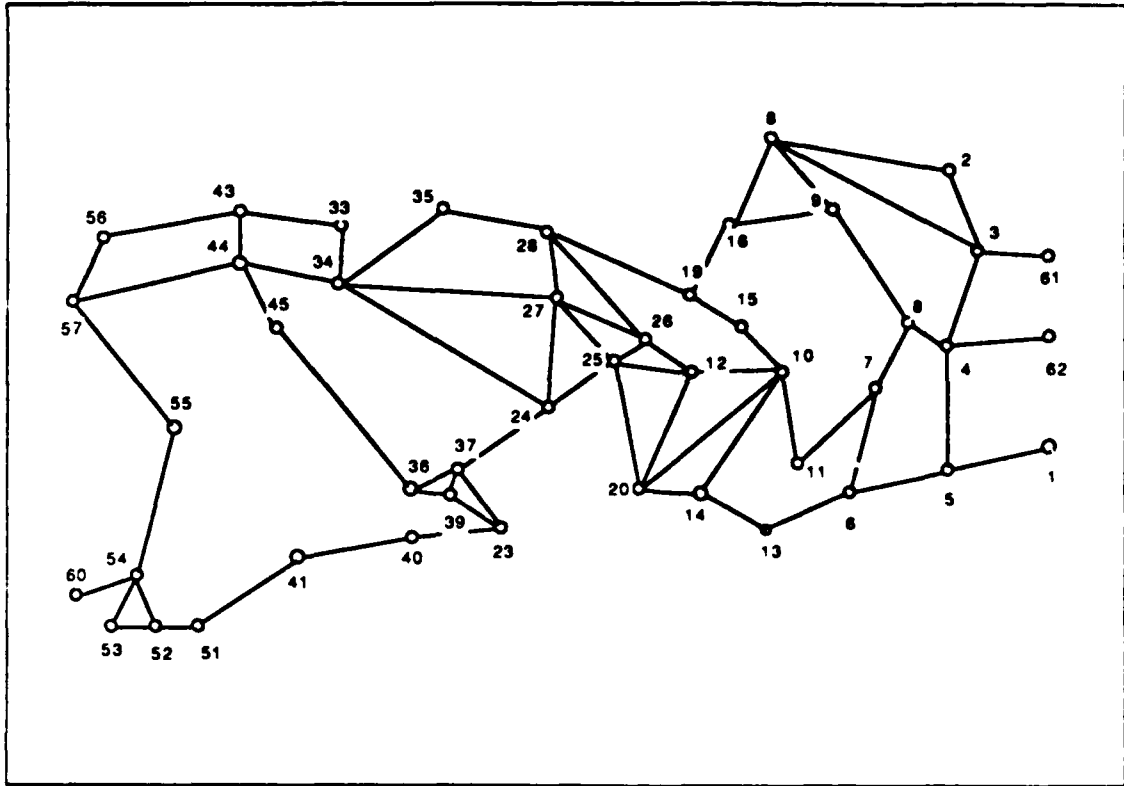

Figure 4.7 Connected Network.

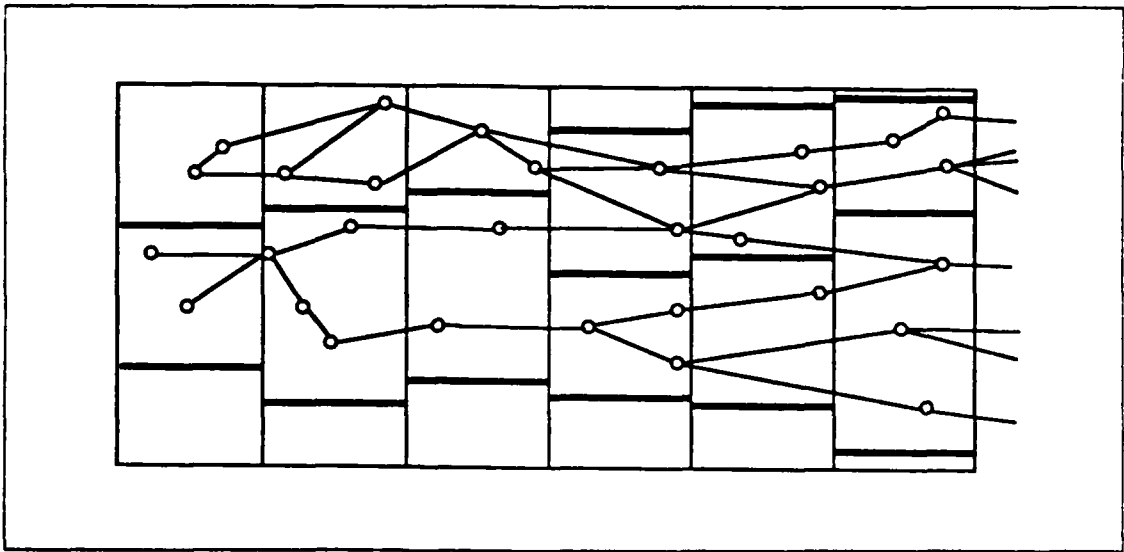

Figure 4.8 Mobility Corridors.

A visual representation of this search for information on enemy entities residing on the terrain network is provided in Figure 4.9. An excerpt from Hartman [Ref. 9: pp. 5.1 - 5.18], follows to further illustrate the target search process that occurs within the mobility corridors.

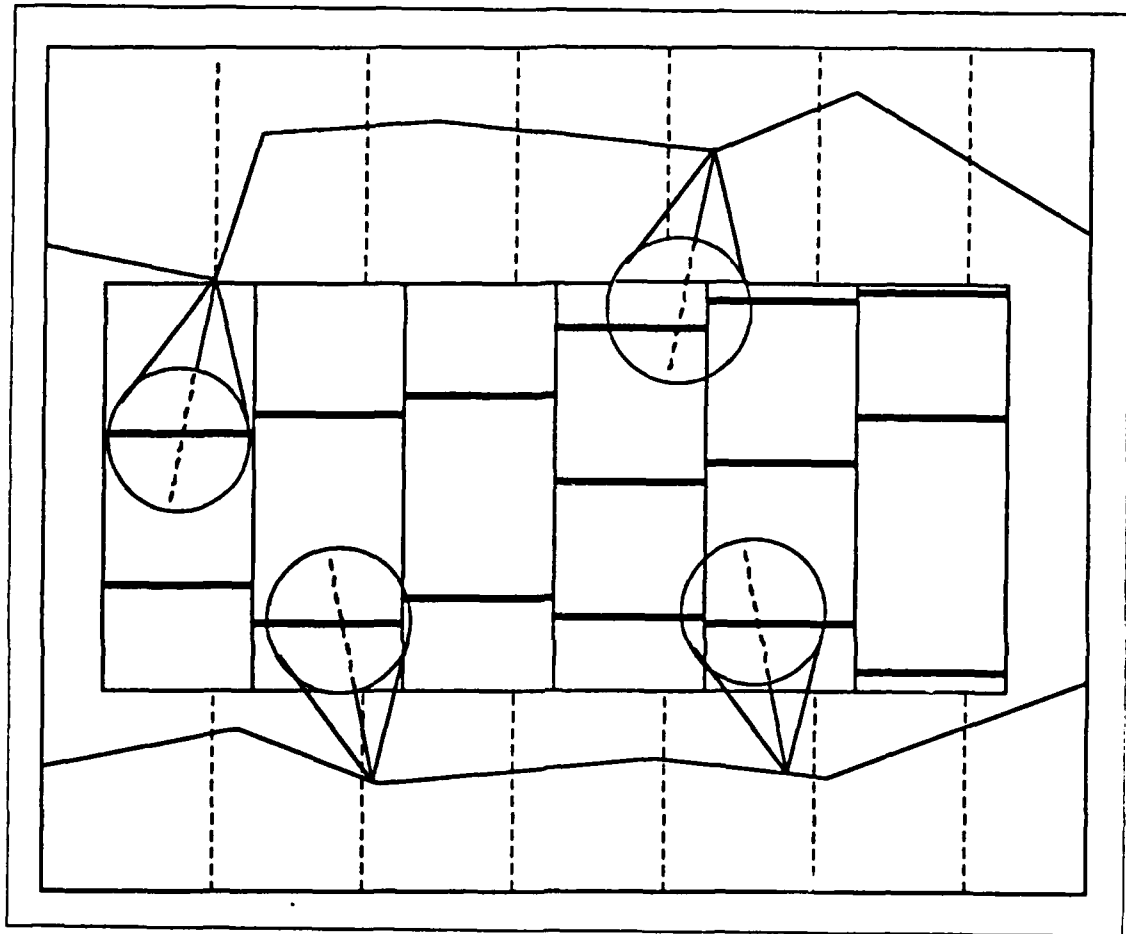

Figure 4.9 Visual Representation.

#### 4. The Search Process

The objective of this section is to provide the reader insight on the search process that will occur within the execution model. This process will determine if any entities are to be detected when collection platforms attempt to provide the simulated reconnaissance function within mobility corridors.

Many factors may interact or function independently to influence target detection in a simulation model. Some examples of these factors are target type, target movement, observed background complexity, atmospheric visibility, sensor device, platform movement, and current ambient light [Ref. 9: p. 4.4]. The various search models, which accompany detection distributions, described are based on the following assumptions:

- The sensor device is carried on an airborne collection platform which can move at a constant speed along any path of connected nodes in the search area.
- The sensor has a maximum range,  $R_{\max}$ , which is a field of view (footprint) smaller than the search area.
- Assuming that a single target is present somewhere in the search area, the symbol  $A$  will denote both the search area and its size or geometric area.
- Assume that the target is stationary. It will not react to the presence of the collection platform in an attempt to avoid detection.
- Assume that the target location is random on the terrain network. There is nothing significantly different about the characteristics of the surrounding terrain that provides additional information to the platform concerning where to look.

To begin the search process, the path along which the platform traverses must be described. As the platform moves through the search area, it may, at some time,  $t$ , be within  $R_{\max}$  of the target.  $R_{\max}$  is defined as the maximum detection range of which a given sensor-platform combination has a chance of achieving a detection.

*a. Relative Motion Coordinates*

Suppose that a coordinate system is defined with the Y coordinate axis parallel to the platform's path and the X axis normal to the path. The platform is viewed as being stationary in this relative coordinate system, located at position (0,0). The resulting footprint provided by the sensor is restricted to a circle of radius,  $R_{\max}$ , centered on the position of the platform. The target is pictured to move past the platform in the direction of decreasing Y with X constant. This holds for all straight line search paths.

The lateral range,  $L_{rg}$ , is defined as the closest approach distance between the platform and the target. In relative motion coordinates, lateral range is the distance from the target path to the observer at (0,0) which is simply the constant X coordinate of the target (see Figure 4.10).

*b. Searching with a Range Law Device*

Suppose the sensor, situated on the collection platform, provides perfect coverage within a field of view. The field of view is modelled as a circle with radius,

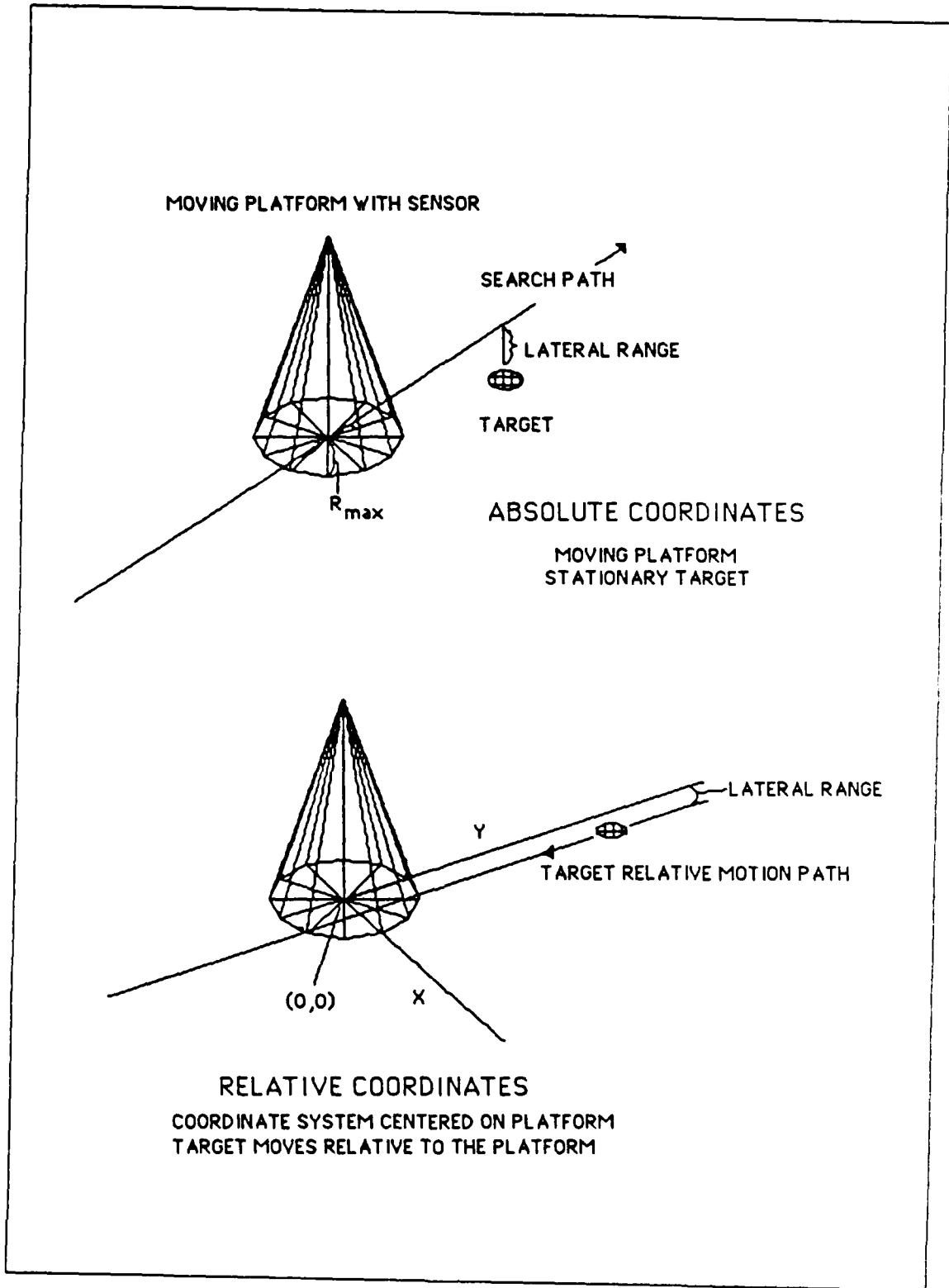

Figure 4.10 Relative Motion Coordinates.

$R_{\max}$  projected onto the terrain network and centered on the platform. As the search unfolds along the various arcs, a target will be detected if the target is ever covered by the circular footprint. Such a sensor is defined as a definite range law device or a cookie-cutter sensor. In relative motion coordinates, the target will be detected if the lateral range is less than the maximum sensor range.

The effectiveness of a sensor is described by a lateral range curve,  $PBAR(x)$ , which yields the probability of detection as a function of the lateral range (see Figure 4.11). For the definite range law device,

$$PBAR(x) = 1.0 \text{ if } x \leq R_{\max}, x = 0 \text{ otherwise} \quad (\text{eqn 4.1})$$

As the platform moves through the search area, the sensor coverage pattern sweeps out a covered area of width,

$$W = 2 \times R_{\max} \quad (\text{eqn 4.2})$$

If the platform moves along an arc through the search area at a constant speed,  $V$ , for a total search time,  $T$ , the total path length covered would be

$$L = V \times T. \quad (\text{eqn 4.3})$$

Assume the search pattern is arranged such that the total search path is traveled without any overlap<sup>5</sup> of the coverage pattern. Ignoring the edge and corner effects, the total area covered by the search is,

$$L \times W = V \times T \times W. \quad (\text{eqn 4.4})$$

A randomly located target will be detected if and only if it is inside this covered area. It follows that the probability of detection is simply a fraction of the total area covered by the search,

$$\begin{aligned} PDET(T) &= \text{Pr}(\text{detection in time, } T) \\ &= L \times W / A \end{aligned}$$

---

<sup>5</sup>Overlapping coverage does not improve the probability of detecting a target because the sensor is perfect inside its field of view.

$$= T \times V \times W / A$$

$$\text{PDET}(T) = S \times T \quad (\text{eqn 4.5})$$

S is defined as the search rate ( $S = V \times W / A$ ). This is valid for path lengths up to  $L_{\text{max}} = A / W$ , when the entire search area has been covered. Maximum coverage occurs when the search time is,

$$T_{\text{max}} = A / (V \times W) = 1 / S \quad (\text{eqn 4.6})$$

and  $\text{PDET}(T_{\text{max}}) = 1.0$ . For  $T < T_{\text{max}}$ , the marginal return from each incremental unit of search time is  $S = V \times W / A$ , which is the slope of the detection probability curve (see Figure 4.12).

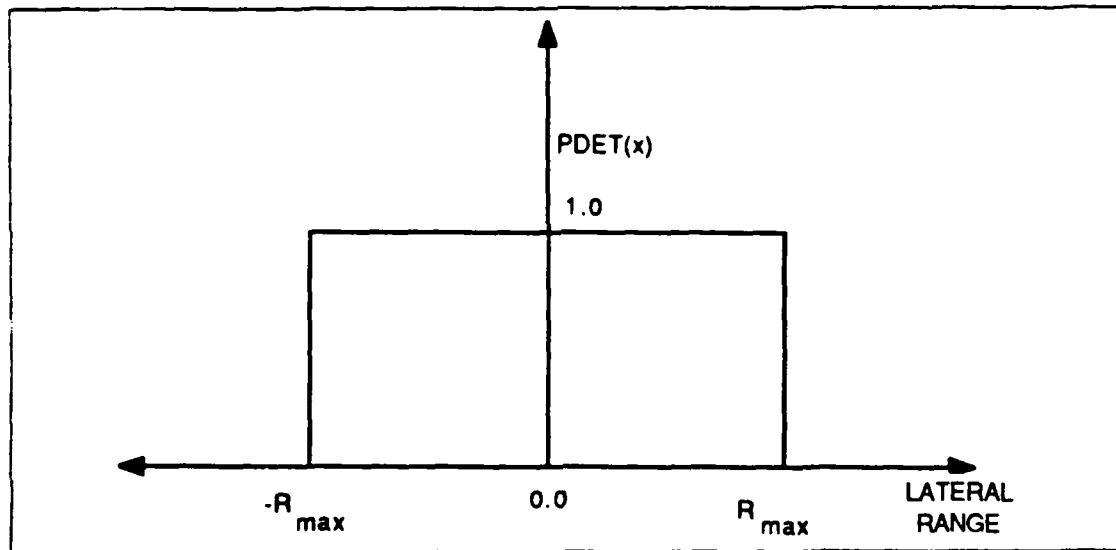

Figure 4.11 Lateral Range Curve for a Cookie-Cutter Sensor.

*c. Searching with an Arbitrary Device*

The final search example to be described is carried out with an arbitrary sensor device. The sensor has an associated effectiveness pattern which is within its  $R_{\text{max}}$ . The lateral range curve for such a sensor is defined as  $\text{PBAR}(x)$ , which is the probability of detection if the sensor moves at a constant speed,  $V$ , along the search path (see Figure 4.13).

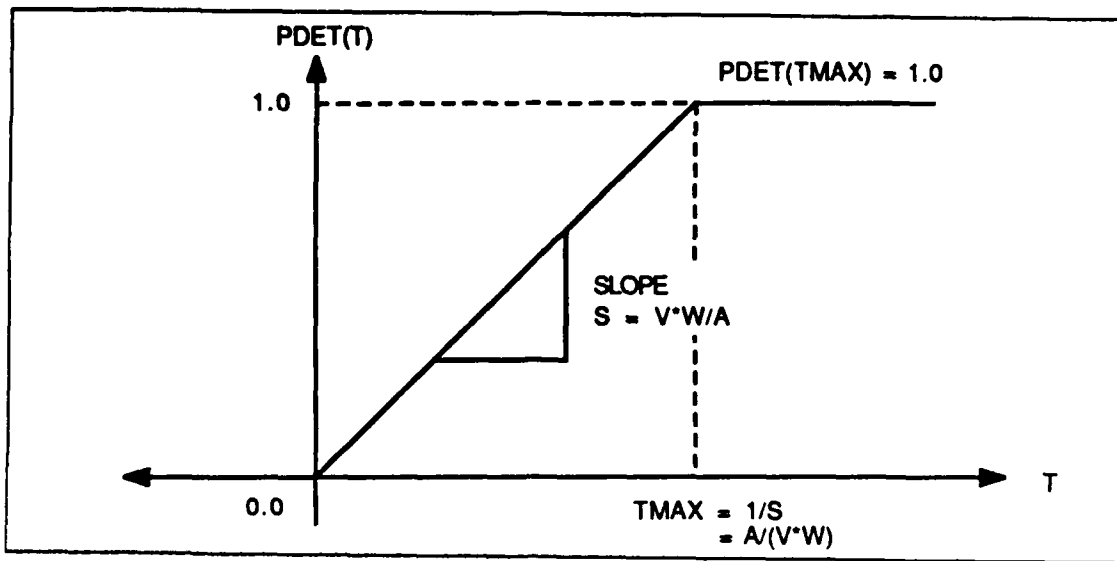

Figure 4.12 PDET for Non-overlapping Search with  $W = 2 \times R_{max}$ .

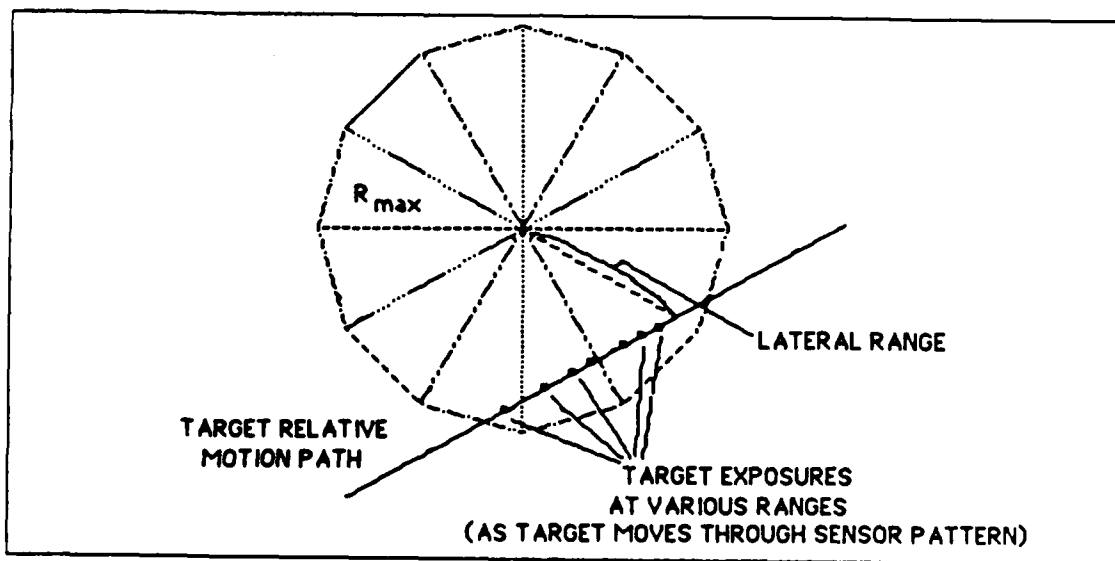

Figure 4.13 PBAR for an Arbitrary Sensor.

Two factors interact to determine  $PBAR(x)$ :

1. The exposure time as the target moves, relative to the platform, along its path through the sensor effectiveness pattern.
2. The sensor detection rate at each point along the path.

$PBAR(x)$  is obtained by integrating over all detection opportunities while the target is in the sensor's field of view. Typical  $PBAR(x)$  curves are shown in Figure 4.14.

The sensor sweep<sup>6</sup> width is defined to be  $W$ , the area under the lateral range curve.

$$W = \int \{-R_{\max}, R_{\max}\} PBAR(x) dx \quad (\text{eqn 4.7})$$

In order to search without overlap, suppose that the target is randomly located in search area  $A$  along a path of length,  $L = V \times T$ . Using a sensor with a lateral range curve  $PBAR(x)$ , an area,  $2 \times R_{\max} \times L$  will be covered by the sensor. The resulting probability of the target entering the sensor pattern is the fraction of the area covered, or

$$\Pr(\text{target enters footprint}) = \Pr(L_{rg} \text{ satisfies } -R_{\max} < x < R_{\max}) \quad (\text{eqn 4.8})$$

If the sensor is not a definite range law device, then the sensor may fail to detect the target even if it enters the sensor pattern. The detection probability is obtained by accounting for all possible lateral ranges in the coverage pattern,  $PDET(T) = (\text{fraction of the area covered}) \times (PDET | \text{the target is covered})$ ,

$$PDET(T) = (2 \times R_{\max} \times L/A) \times \int \{-R_{\max}, R_{\max}\} PBAR F(x) dx \quad (\text{eqn 4.9})$$

$F(x)$  is the probability density that the lateral range has value,  $x$ , given that it is located somewhere in the range  $\{-R_{\max}, R_{\max}\}$ . Of note is that  $F(x)$  is uniformly distributed on  $\{-R_{\max}, R_{\max}\}$  because the target is located randomly. Thus,

$$\begin{aligned} PDET(T) &= \Pr(\text{detection in time, } T) \\ &= S \times T. \end{aligned}$$

---

<sup>6</sup>Note: this is consistent with the definition of  $W$  for the definite range law device. The sweep width must always satisfy  $W \leq 2 \times R_{\max}$ . An equality only applies in the case of the definite range law sensor.

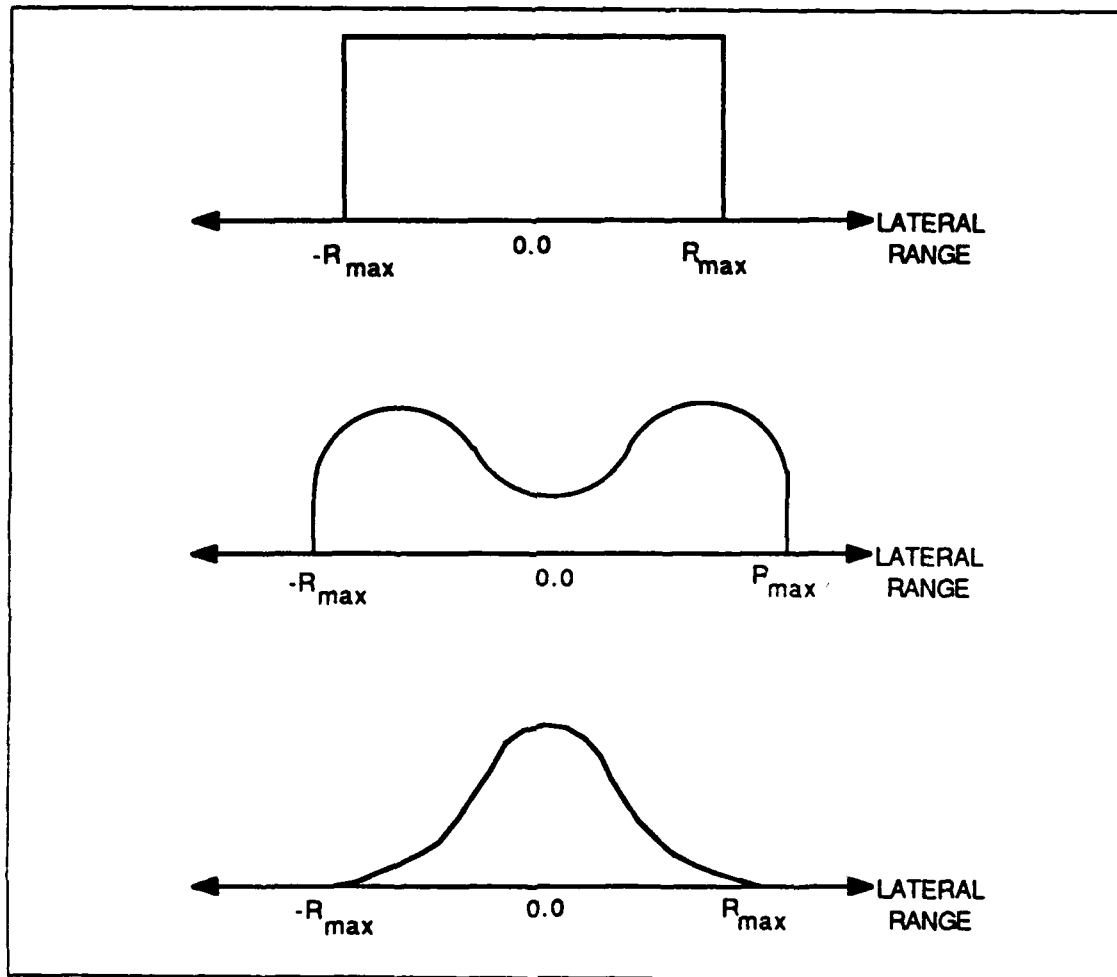

Figure 4.14 Typical Lateral Range Curves.

When a non-overlapping search (see Figure 4.15) is conducted with the arbitrary sensing device, the largest path that can be searched before overlap occurs is  $L_{max} = A / (2 \times R_{max})$ . Thus,

$$PDET(T_{max}) = W / (2 \times R_{max}) \quad (\text{eqn 4.10})$$

The value of  $PDET(T_{max})$  is less than 1.0 if  $W < 2 \times R_{max}$ .

The TAR model consists of two functions, collection management and information acquisition. The next sections will describe the attributes required of the TAR model, beginning with the request for reconnaissance.

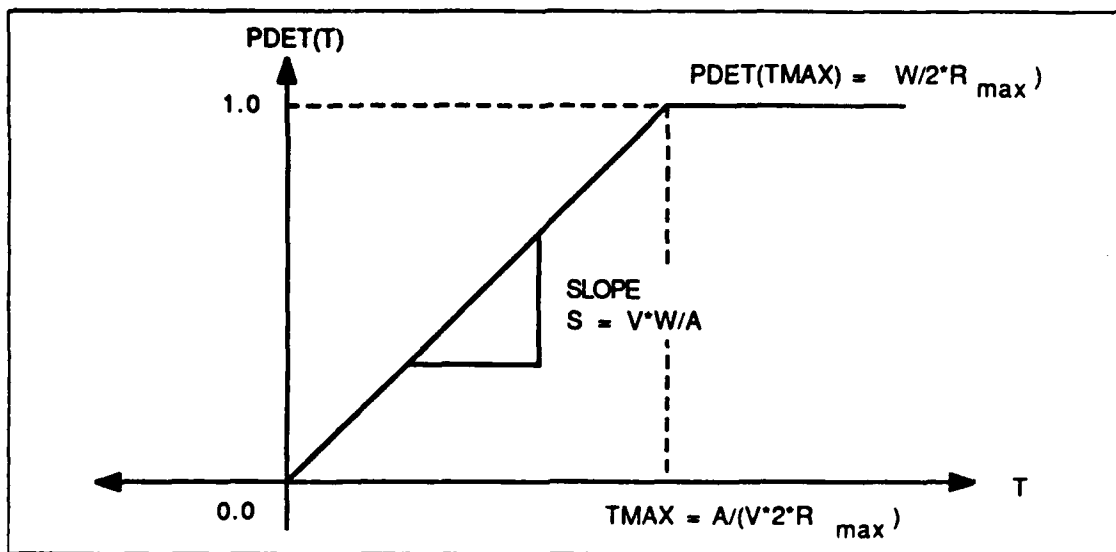

Figure 4.15 PDET for Non-overlapping Search with  $W < 2 \times R_{\max}$ .

## B. REQUEST FOR RECONNAISSANCE

Since the role of reconnaissance operations is to keep the perception database as current as possible, a request (see Figure 4.16) can be viewed as a query (15) directed at the perceived database. Each query is based on the time of the last database update (16). The information pertains to nodes and arcs contained within a region designated by sector coordinates of the mission order. A request (18) for TAR is initiated when this information is not in the database (17) or if the information is too old.<sup>7</sup> Two classes of requests may be generated, preplanned (routine) or immediate.

### 1. Preplanned Requests

Preplanned requests are initiated for information requirements that are foreseen. Once the initial data is input into the model and the corps area of interest is determined, a preplanned mission list is formulated to provide surveillance of each command level's area of interest. This consists of dividing regions (containing enemy expected avenues of approach) into smaller sections called sectors, comparing the coordinates of these areas with the coordinates received from the corps level mission

<sup>7</sup>Refers to the passage of simulated time relative to the last perceived database update. The required timeliness of perceptions is a research issue yet to be addressed. For example, what is the relative difference in utility of information obtained 15 minutes earlier? ...45 minutes earlier? Additionally, how does this need for information by time,  $t$ , impact the simulation clock process time that expires when the planning process is being executed?

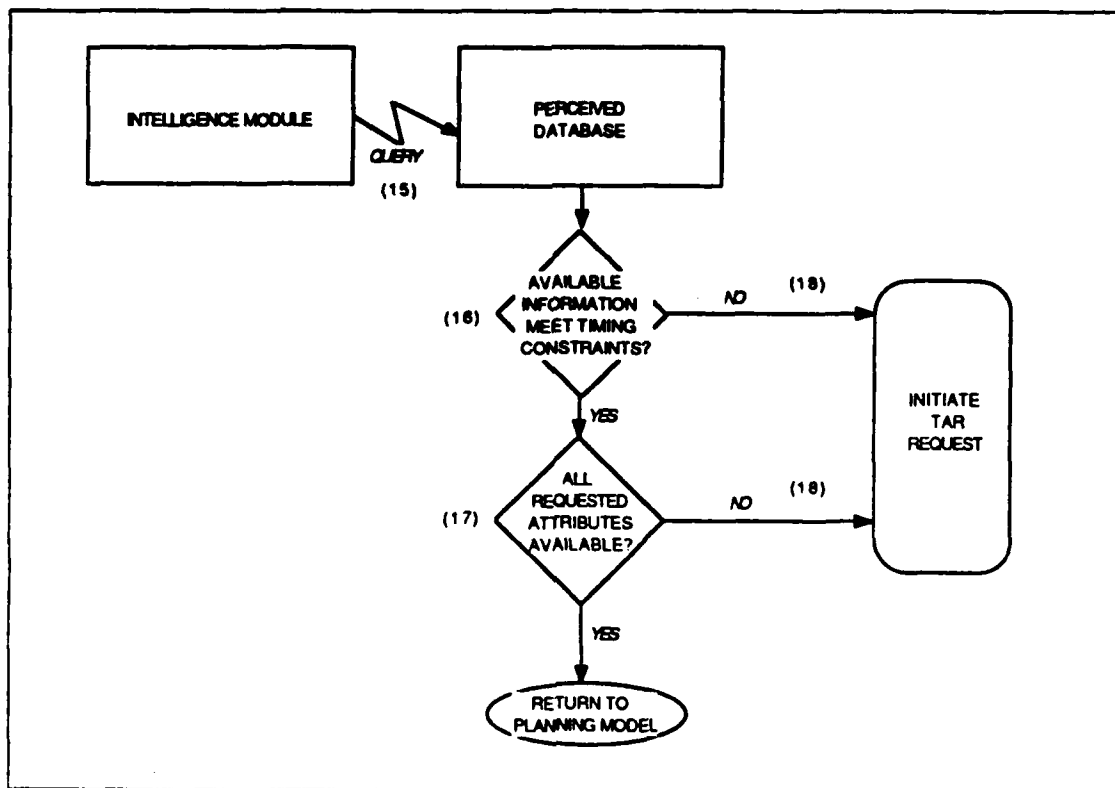

Figure 4.16 Determining When to Initiate a Request.

orders, and requesting the corresponding collection missions. The responsibility for this class of request rests with each IEP. As stated earlier, requests flow through the intelligence module with the IEP performing an inferencing function. Because the IEP predicts enemy mobility corridors, it seems plausible that the IEP act to substantiate its predictions by generating a prioritized list of preplanned (routine) reconnaissance missions. Prioritization in this context refers to the timing window in which the information is required.

## 2. Immediate Requests

Immediate requests are generated to meet specific information requirements which cannot be satisfied by the preplanned missions. These requests stem from the case where a command level becomes aware that a significant deviation from the macro plan has occurred. Micro planning would result in an attempt to restore the simulated battlefield situation to one that would permit the accomplishment of the existing macro

plan. [Ref. 3: p. 35] Invocation of the planning mode may require an immediate update to the perceived database in the form of a timely mission that is capable of providing a point update of a designated node.

### **C. REQUEST COMPONENTS**

Requests enter the TAR model and are immediately time tagged. This provides a base time to determine how long requests remain in the system. Because requests determine when to look, what to look for, and where to look, the proposed components of all requests are as follows:

- **Time entered system:** simulation clock process time in which a request was received from the IEP.
- **Request number:** sequential numbering scheme.
- **Area of interest:** node numbers corresponding to the locations of the nodes and arcs of interest.
- **Range to target area:** sum of the distances of arcs along the shortest path to the target area.
- **Coverage type:** the sensor type(s) to be used on a collection platform.
- **Timing window:** the period of time preceding a decision period in which the information is required.

The request number is merely a sequential numbering of requests that enter the request queue. The area of interest refers to the sector of the battlefield upon which information is required. As alluded to earlier, each sector is composed of nodes, arcs and target attributes. Nodes correspond to ground positions that are connected by routes or arcs and may represent a bridge, city, or just a certain segment of the terrain. Nodes may contain force units which are composed of entities. Entities are defined as the individual combat vehicles, facilities, or weapon systems. Each simulated combat entity possesses several attributes. Attributes, also referred to as state variables, describe the state of each entity.

The air space from which targets are to be detected can be viewed as a series of three dimensional projections from nodes of the terrain network. Each node is numbered, thus range is defined as the minimum distance to a given node contained in the area of interest to the requesting unit's location. Range would actually be expressed in terms of coordinates. Coverage type refers to the sensor system on a platform used to acquire the requested information. The sensor system selected is a function of several parameters, type of target, amount of coverage area desired, and the perceived threat environment.

The timing window actually consists of two times: a not earlier than (NET) time and a not later than (NLT) time. These times refer to the earliest and latest possible simulated clock process times that the information is required by the planning model in order to be useful in the current formulation of macro plans. To illustrate the use of these times refer back to the decision<sup>8</sup>period. The decision period was defined as the maximum period of time allotted to a particular command level decision task to accomplish an assigned mission. The mission has an associated start time,  $t_p$ , and an end time,  $t_e$ . Additionally, through updates to the perceived database, several times in which forces are to engage enemy force entities,  $t_{eng}$ , are determined. Given  $t_p$  and the current simulation clock process time,  $t_x$ , some time  $t_{p-x}$  is determined to be the first clock time an update is required. More specifically, it determines when the timing of the current perceived information exceeds some predetermined threshold such that an information update is required. This clock time is the NET. The NLT refers to the clock time when a final update to the perceived database is required before the decision period begins. The length of time between the NET and the NLT is called the timing window. A procedure to calculate these information requirement times is a research issue yet to be addressed.

#### 1. Collection Management

Receipt of a request for information initiates the collection management portion of the TAR model. The collection management function is responsible for front end processing of all requests and determination of request validity. The collection management function exists because there is a limited quantity of collector resources and serves as the central repository for all requests. Nomination of the areas that should be covered by each individual search process is determined as well as the nature of each search in order to minimize search errors. The end product of the collection management function is a scheduled reconnaissance events collection plan. The plan is based on collection assets available, their capabilities, time of required sensor coverage, and the stated information requirements. The collection management function is subdivided into two parts: request validation and collection plan generation.

---

<sup>8</sup>The main simulation event list consists of a sequence of times, of which each decision period is a subset, i.e. ( $t_{p-x}, \dots, t_{p-2}, t_{p-1}, t_p, t_{p+1}, t_{p+2}, \dots, t_e, t_{e+1}, \dots$ )

*a. Request Validation*

Validating a request is a confirmation procedure that ensures each request's continuation through the TAR model, Figure 4.17. This consists of evaluating the three possible conditions that could cause a request to be cancelled. The three general conditions are: the area to be reconnoitered is no longer of interest, information on an area of interest is to be updated by other means, or the expected collection platform losses are too high.

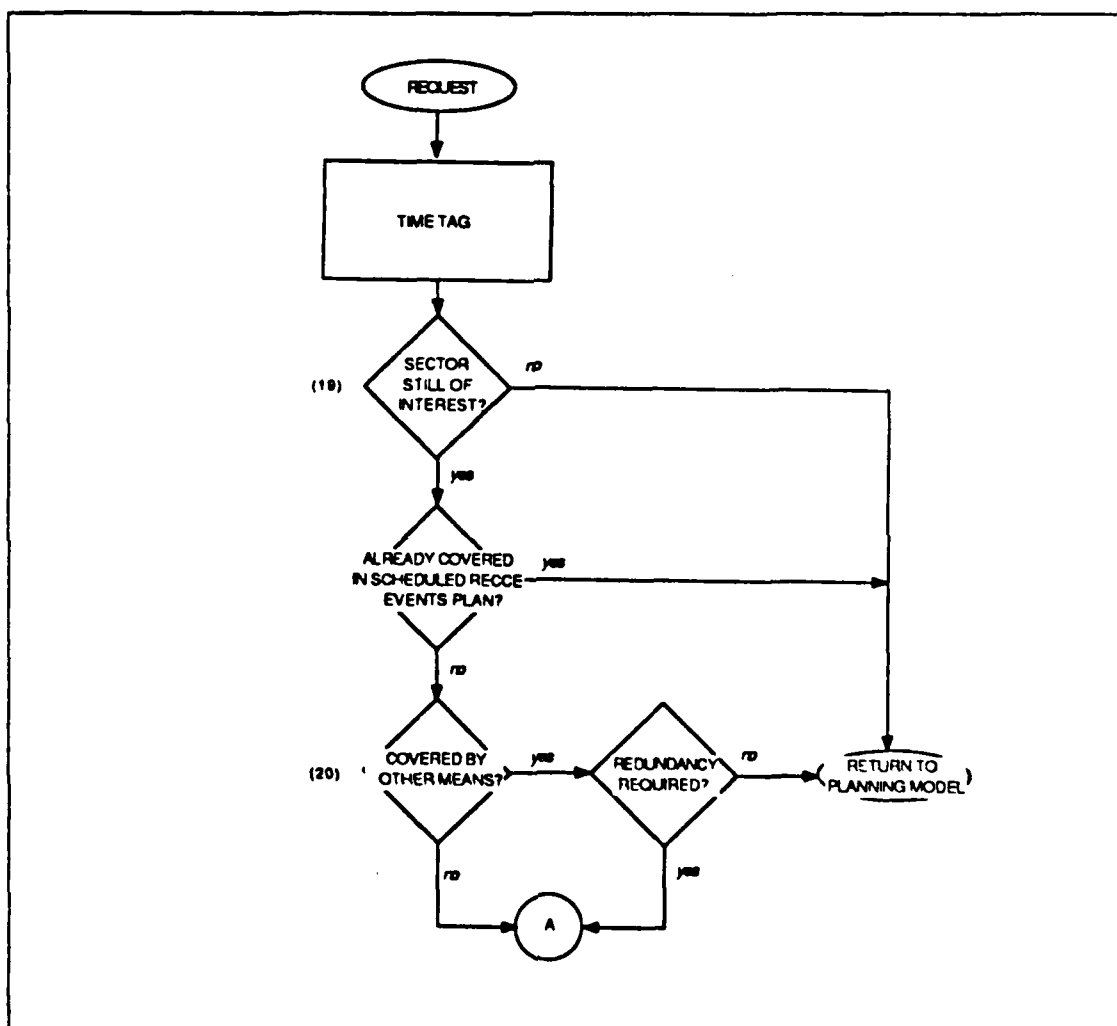

Figure 4.17 Collection Management Request Validation.

The first step in the validation procedure is to determine if the sector of the battlefield designated in the collection request is still of interest (19). For example,

suppose the coordinates of the sector of interest, A, have changed due to an infeasibility associated with the macro plan. A new area, A', may become the sector of interest, thus preempting the original request for information in sector A. It may not be feasible to continue the request to reconnoiter sector A. Each request has resource implications, therefore collection assets must be employed selectively.

The perceived database is envisioned to receive updates from three sources (20). These sources, as shown in Figure 4.18, are ground organic, TAR, and national collection assets. At this time intelligence updates from sources other than TAR is

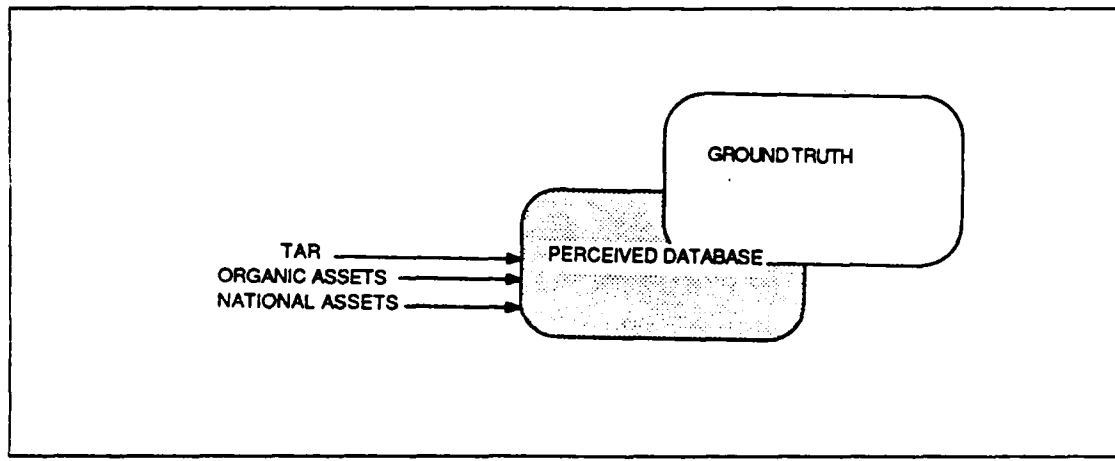

Figure 4.18 Collection Inputs to the Perceived Database.

assumed to be handled simply as periodic updates to the perceived database.

Ground organic collection assets will provide periodically updated information obtained in areas approximately five to 25 kilometers from the FLOT in each respective area of influence while national collection assets provide periodic extended range coverage. The national assets provide coverage from collection platforms such as satellites or possibly extremely high altitude platforms. Periodic information provided by these high altitude collection platforms provide the database details through imaging techniques or simulated signals intelligence (SIGINT). Imagery is a process of providing photographic-type details of objects or areas, thus updates received through this means may provide information regarding the terrain network or enemy force composition. SIGINT is a process of intercepting electromagnetic emissions and the associated perceived information may possibly provide updates on the enemy's operating location or characteristics of his weapons

and equipment. Although the types of information obtained by high altitude collection assets can be extremely valuable in the development of macro plans, it may have limited utility. Meteorological conditions may hamper the performance of imaging systems thereby affecting the timeliness of updates to the perceived database. Redundant coverage (i.e. by national and TAR collection assets) may be required to attain a minimum acceptable probability of a successful collection mission.

If the requested area to be reconnoitered is adequately<sup>9</sup> covered by periodic collection efforts then, from an optimization perspective, the request for TAR should be cancelled. Other checks that must be performed are:

- Is the sector partially or completely overlapped by other designated collection areas?
- Is the timing of the information updates feasible in order to support macro plan development?

Once requests are validated, they are given a priority (see Figure 4.19) in order to develop a scheduled reconnaissance collection plan. The key element used to develop these plans is the timing window. Since this window refers to the minimum and maximum acceptable times in which collection missions must be performed, the prioritization is determined by ordering requests based primarily on the NLT.

#### ***b. Request Prioritization***

Prioritization begins with determining mission package contents (21). The mission package refers to the mix of collection platforms, sensors, and support systems that provide the responsiveness necessary to accomplish a collection mission. This is an iterative process where expected platform losses (23) due to currently known ground and air threats along routes determined in (22) are calculated. The formulation of feasible routes to and from the target area must be generated by projecting flight paths (22) for the reconnaissance missions. This procedure uses information from the perceived database on node locations of the last known enemy air defense sites and enemy weapon capabilities to generate a network of flight paths. These flight paths represent routes to and from the FLOT, to and from the target area, and from within the target area. Flight paths can be viewed as elevated ground nodes with connecting arcs. The flight path generation procedure is designed to generate the elevated routes by minimizing exposure times to the current perceived enemy air defense threats while being constrained by the information request NLT requirements.

---

<sup>9</sup>The term 'adequately', in this context, refers to whether or not the specific information requirements contained in the request are satisfied. These requirements specify the type of coverage desired.

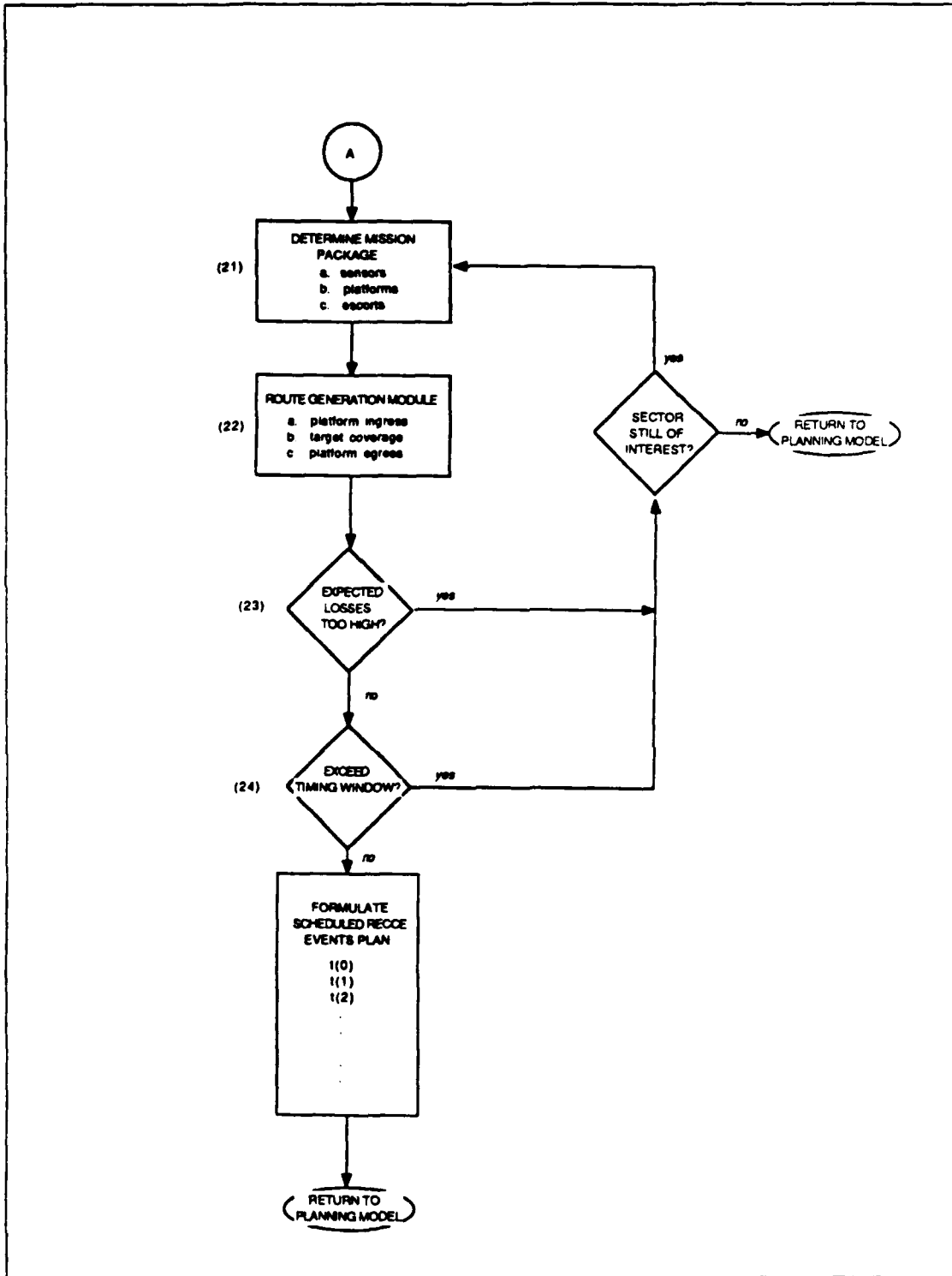

Figure 4.19 Collection Management Request Prioritization.

The process of determining threats to collection platforms may be handled initially in the development of ALARM as a front end data input to the model. Tables consisting of enemy force threat codes and the corresponding mission packages can be formulated a priori. The threat code refers to the perceived threat along a selected flight path, while the mission package may include several escort fighter type platforms.

An additional constraint placed on the procedure to develop a mission package is to compose the package with the minimum number of resources. This procedure may take several iterations to complete due to the probability of a successful mission, forecasted in (23), not reaching an acceptable level, given the perceived threat environment and the information timing requirements stated in the request for TAR. If a feasible mission package cannot be determined, or if losses are perceived to be higher than acceptable to satisfy the request, then the request is forwarded to the national collection function. All requests with feasible expected loss and mission package contents are then checked to ensure the request is still valid and can meet the timing window (24).

### *c. Sensor Functions and Attributes*

The types of sensor functions envisioned for representation in the TAR model are imagery and surveillance radar. A description of each function along with a list of attributes follows.

(1) *Imagery.* Imagery derived reconnaissance is a key element in supporting information needs for the development of macro plans. Imagery is defined as sensors capable of providing "photographic" type information of entities on the terrain network. Sensor types capable of providing these battlefield pictures are optical, infra-red (IR), and radar.

An optical sensing function or aerial photography was used as far back in American history as the Civil War. During that time artists drew sketches of the battlefield while elevated in captive balloons [Ref. 10: p. 157]. In fact, studies have shown that during World War II approximately 80% of all useful military intelligence came from aerial reconnaissance photographs [Ref. 10: p. 125]. The basic principle of the optical capabilities is that targets reflect a signature in the visible light spectrum that is measured as a visual contrast with the environment. This is conducted along a straight path between the target area and collection platform called the line of sight (LOS). A rough estimate of the distance a man can see, assuming the fictitious fellow is in the middle a calm ocean and ignoring meteorological distortion, is  $d = \sqrt{(1.5)h}$ .

where  $d$  is the distance in miles and  $h$  is the height above sea level in feet. Thus, a six foot man can see approximately three miles. Elevate him to a height of 66 feet and his horizon stretches to 10 miles. From a radar equipped platform orbiting at 35,000 ft., the horizon is no less than 230 miles. The minimum practical height for a reconnaissance satellite is about 100 miles and they can theoretically "see" about 890 miles! [Ref. 11: p. 7] Despite other significant and sophisticated monitoring devices, the photograph is perhaps the most important piece of information a unit command level's intelligence module can receive to initiate or verify plans.

Photographic reconnaissance cameras take a succession of individual glimpses<sup>10</sup> with shutter speeds varying between 1/1000 and 1/3000 seconds. The speed at which each glimpse is executed varies according to the particular platform's image motion compensation (IMC) needs. IMC calculations are derived from inputs about the platform's altitude and speed. It causes adjustments to be made so that blurry frames are minimized due to the frame rate not being equivalent to the rate at which images traverse the lens aperture. The lens aperture is adjusted automatically to the ambient light, film type, and other variables. For night reconnaissance operations, the camera is assumed to take a sequence of glimpses when photoflash cartridges, ejected from the platform, illuminate the immediate area.

The two basic slant angles in which imagery is obtained are vertical and oblique. Vertical slants furnish coverage of the search area from directly above a target while oblique slants provide a view of an area from an angle not directly over the target. Towards the edges coverage is poor, partly due to the distance from the platform to the target and partly because of an almost horizontal grazing angle. Vertical zones are seen to provide the most information without loss around edges.

Infra-red (IR) imagery permits the detection of thermal energy. Fundamentally, any entity or source that radiates heat can be an IR emitter. Each emitter possesses a particular pattern of emission called an IR signature. The signature emanating from the source is normally different from the temperature of the background environment. Thus a thermal contrast results, permitting detection of the entity. These sensors yield a picture-like rendition of the target entity and background which also provides the means for detecting camouflaged objects. Enemy entities possessing attributes of buildings, airfields, or artillery batteries that are camouflaged, for example, can be detected in simulated day or night activities.

---

<sup>10</sup>Glimpse is a search process explained by Smith, see [Ref. 8].

IR sensors provide either a point or area detection capability. This refers to the field of view provided by the sensor. Point detection implies a narrow field of view, possibly concentrated on a single node. Area detection is essentially several point detectors connected in parallel and capable of covering a wider area. The main difference in these capabilities is that it takes less time to process a narrow field of view than to process an area. In the model, this may be a prime consideration if near real-time updates to the perceived database are required.

The final type of imagery is radar imagery which is still concentrated at detecting ground targets. The typical radar is a side looking radar that can sweep across the ground network out of either side of the collection platform. These sensors provide information on moving targets as well as imagery by detecting shifts in the frequency of energy reflected off of ground entities.

(2) *Surveillance Radar.* A surveillance radar capability is necessary to provide information on enemy air activity to the perceived database. The basic principle of radar is range measurement by timing echoes, produced by electromagnetic energy, bounced off of a target. The burst of energy travels at the speed of light which is  $3 \times 10^8$  meters per second. Using the distance formula, the length of time required for the energy burst to be reflected from a target one nautical mile away is 12.35 microseconds. This is defined as a radar mile. Therefore, energy transmitted at time,  $t_0$ , and received 1235 microseconds later means that the distance to the target is 100 nautical miles and located somewhere within the radiation pattern of the transmitting antenna. Azimuth, defined as the angle of horizontal deviation measured clockwise from north, is determined by narrowing the width of the transmitted beam. The beam is then rotated until the direction of maximum return energy is found. This point in which maximum energy is received is the direction of the echo. If the beamwidth of the transmitting antenna were 1 degree, then the target azimuth would be known to within a maximum error of 1 degree. Now, if the transmitting antenna were rotated through a full 360 degrees, the transmitter energy turned on and off at timed intervals, and all echos received were correlated with the azimuths at the time each echo was received, then scanning would result. Scan duration is the time required for one complete rotation of the antenna.

(3) *Collector Attributes.* Each simulated collector has several attributes to describe its unique situation. The following attributes are basic to each sensor-platform combination. First, maximum effective range into enemy defenses is normally

an attribute that is associated with the platform and should be distinguished from detection range which is a sensor characteristic. This variable is heavily influenced by factors such as prevailing weather or condition of the platform. The second attribute is a sensor descriptor which stipulates the necessary conditions to detect a target by a sensor type. This attribute is a function of the range, time of observation, and the intensiveness of the reconnaissance collection mission. The third basic attribute is primarily a sensor characteristic which centers on the accuracy provided in target determination. The magnitude of the errors for a given device is a function of the distance to the target, environmental conditions, and the time of intelligence processing performed by the CIP. Next and quite important is the aspect of time. Of particular interest is the segment of simulation clock process time that elapses from the moment of target detection to the moment the collected data reaches the appropriate intelligence node. Depending on the collection means, this time may be very short or of substantial duration. An additional component is the time lag which is the simulation clock process time from the moment TAR missions are assigned to the moment of target detection. Other attributes that accompany each collection platform are included in Appendix A.

## **2. The Scheduled Reconnaissance Mission Timing Plan**

Following request validation, each request is entered into a mission timing plan. The purpose of these collection plans is to alert the execution model that a collection event is to occur. Each collection plan covers a 24 hour simulation clock process period of time. Creation of a plan simplifies the insertion of missions generated by immediate requests for reconnaissance. Within the 24 hour time period only a finite number of missions can be carried out because activities such as maintenance must be accounted for and an infinite supply of platforms does not exist. All scheduled missions are placed into time slots that are subsets of the time horizon covered by the reconnaissance event list. The next batch of reconnaissance missions would be listed in the next scheduled events list depending on the timing requirements of the requested information.

## **3. Information Acquisition**

Information acquisition is the procedure, carried out within the execution model, to actually collect information and update the perception database (see Figure 4.20). The procedure begins with the launch (25) of a mission package whose contents has been determined by the collection management function. Once within proximity to acquire information, the collection begins (26).

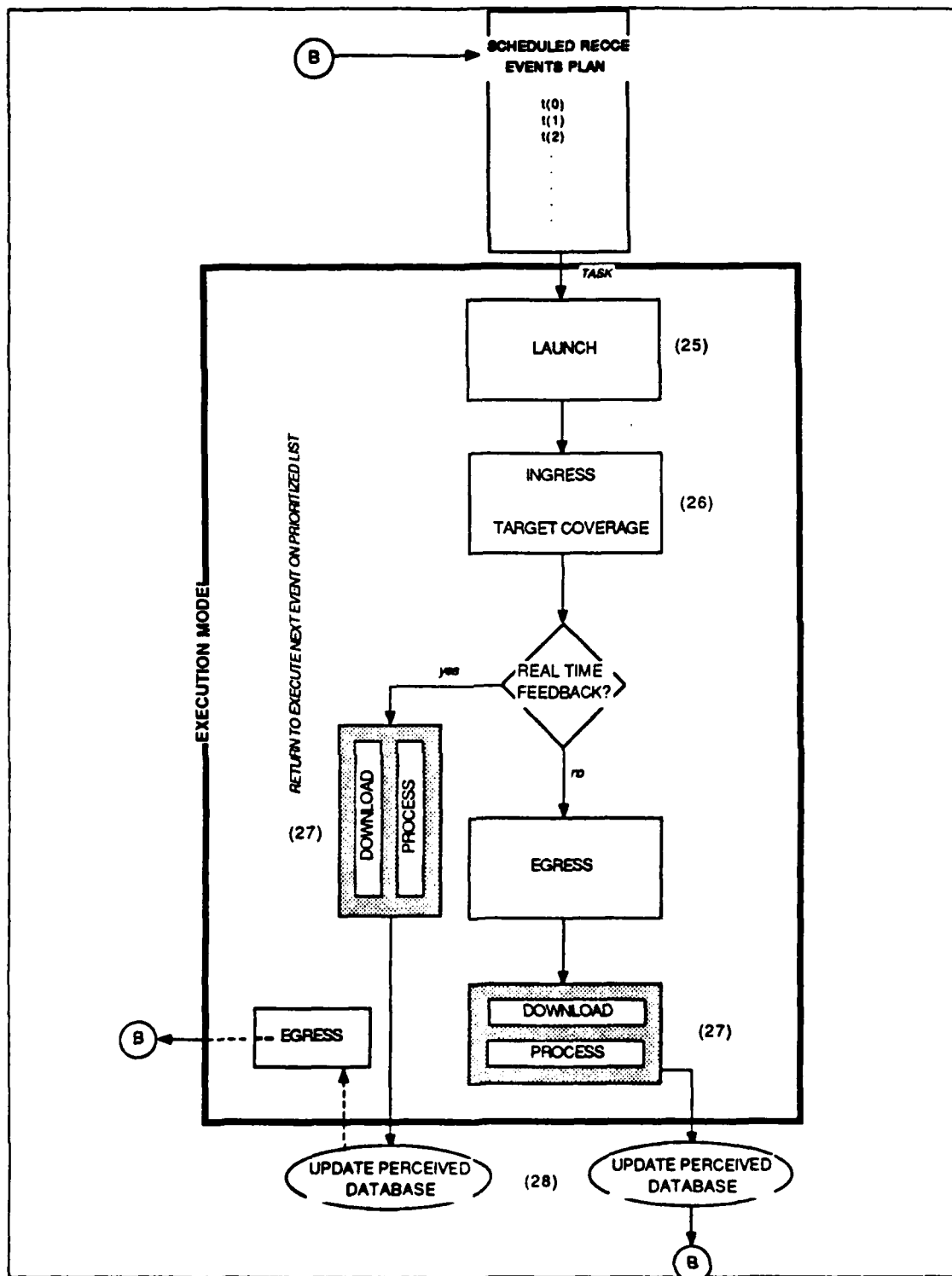

Figure 4.20 Information Acquisition Flow.

The three target categories of which information is to be collected against are fixed, mobile, and moving. Fixed targets are those entities that are not readily movable. For example, hardened C<sup>2</sup> facilities are fixed targets. The second type of target is the mobile target. These targets exist at a particular location for a limited amount of time. The final category of target consists of moving targets. These targets are highly mobile and may be difficult to locate. The fundamental target acquisition process used to acquire these targets is as follows. [Ref. 9] A differential target signature is transmitted through the atmosphere to the location of the platform. If geometric line of sight (LOS) does not exist, then transmission is blocked, possibly by the terrain, and acquisition will not occur. Even if LOS exists, the target signature may be attenuated by the prevailing atmospheric conditions before it reaches the platform. The target must next enter the sensor's field of view. In the field of view, the attenuated target signature is then processed to form an image of the target scene. Computations are made to account for optical losses in the case where photographic lenses are being utilized on the platform. Following an appropriate time delay to account for the transition of the platform to a collection node, the intelligence is processed and the perception database is updated (27 & 28). The information is then used to update SIP predictions.

#### **D. SUMMARY**

This chapter provides some required decision logic and describes a procedure for requesting tactical airborne reconnaissance to supply updates to the perceived database. In the procedure, all requests are validated and prioritized before entering the scheduled reconnaissance collection plan. This plan is essentially an abstraction for the actual tasking of collection platforms.

The objective of collection platforms is to satisfy information requirements established by the IEP and validated by the collection management function. This objective is accomplished through the utilization of a mix of sensors that are capable of detecting varying forms of enemy activity. The type of sensor selected is a function of any combination of the following factors:

- Enemy threat.
- Range to target and platform range.
- Target characteristics and the characteristics of the collector.
- The terrain and its influence on the collector.
- Timing window and response time of the collector.

- Weather conditions and weather limitations of the collector.

In addition, this chapter includes attributes of the collection platforms and provides an overview of a search process that will occur within the execution model. The search is conducted to determine if entities are to be detected as collection platforms supply the reconnaissance function within mobility corridors. If detection occurs, the information will be passed to the planning model after an appropriate time delay to represent the processing of the information. The information is then used to update the perceived database and determine if the current macro plan is to be modified.

## V. PERCEPTION GENERATION EXAMPLE

### A. SCENARIO

The purpose of this chapter is to demonstrate the application of TAR to update the perceived database by extending an example developed by Fletcher [Ref. 5: pp. 51 - 60]. To proceed, a blue armor brigade has received an order from a higher echelon to defend in its assigned sector against the attack of a red motorized rifle division. The mission objective of the blue force is to prevent the red forces from advancing past the blue brigade's rear boundary area. A troop list representing the assets available to the brigade is received as part of the order input from the higher blue division. For this example, blue force units and characteristics are listed in Table 2. Intelligence received from the IEP along with the mission order is provided in Table 3.

TABLE 2  
BLUE BRIGADE COMPOSITION

$x_i$	UNIT TYPE	BIP <sub>i</sub>	DIST <sub>i</sub>	STATE <sub>i</sub>
$x_1$	Tank Bn.	1000	20 km	1.00
$x_2$	Tank Bn.	1000	20 km	1.00
$x_3$	Tank Bn.	1000	20 km	1.00
$x_4$	Artillery Bn.	800	20 km	1.00

Where;

1.  $x_i$ : entity.
2. UNIT TYPE: the type of unit of which  $x_i$  is a member.
3. DIST<sub>i</sub>: the distance  $x_i$  is from the location in which the mission is to be conducted.
4. STATE<sub>i</sub>: the current condition of the unit which includes the percentage of ammunition, equipment, and personnel that  $x_i$  currently possesses.
5. The decision period is from  $t_{16}$  to  $t_{24}$ .

TABLE 3  
PERCEIVED RED FORCE COMPOSITION

$y_j$	UNIT TYPE	$BIP_j$	$DIST_j$	$STATE_j$
$y_3$	MRR.	3000	45 km	1.00
$y_4$	Tank Rg.	3600	39 km	1.00

The macro plan stipulates an initial allocation of units to defend at the FEBA based on the predicted avenues of approach input provided by the IEP. Additionally, the corresponding rates at which all entities of each force advance and expend supplies is assumed known. The initial macro plan calls for the commitment of tank battalions  $x_1$  and  $x_2$  at the time of engagement,  $t_{16}$ , while all other blue force units remain uncommitted. In order to fully convey the initial set up a visual presentation of red and blue force relative positions is shown in Figure 5.1.

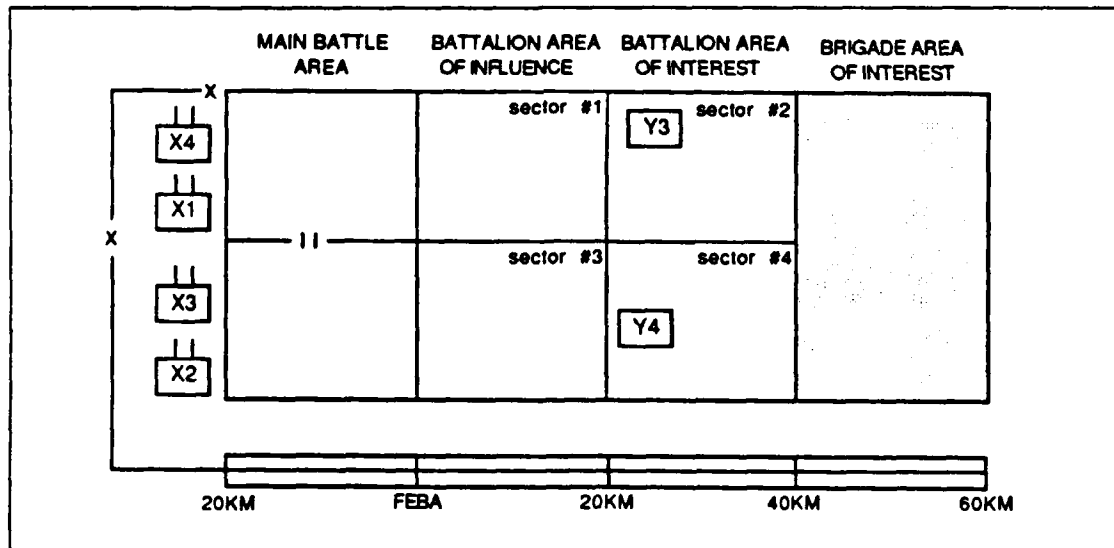

Figure 5.1 Initial Perceived Situation at time  $t_1$   
for the commitment of  $x_1$  and  $x_2$  at  $t_{16}$ .

## B. TIME, $T_0$

Before stepping through the methodology described in chapter IV to determine macro plan feasibility, consider the situation on the timeline at time,  $t_0$  (refer to Appendix B for the complete timeline of events). At  $t_0$  an update to the perceived database has occurred. The search process has resulted in the identification  $y_3$  in brigade sector #2 and  $y_4$  in brigade sector #3. The intelligence module accepts this input and formulates the associated initial red and blue SIP curves (see Figure 5.2). Additionally, the brigade's IEP submits requests for TAR missions in the brigade's area of interest to seek out red follow-on forces.

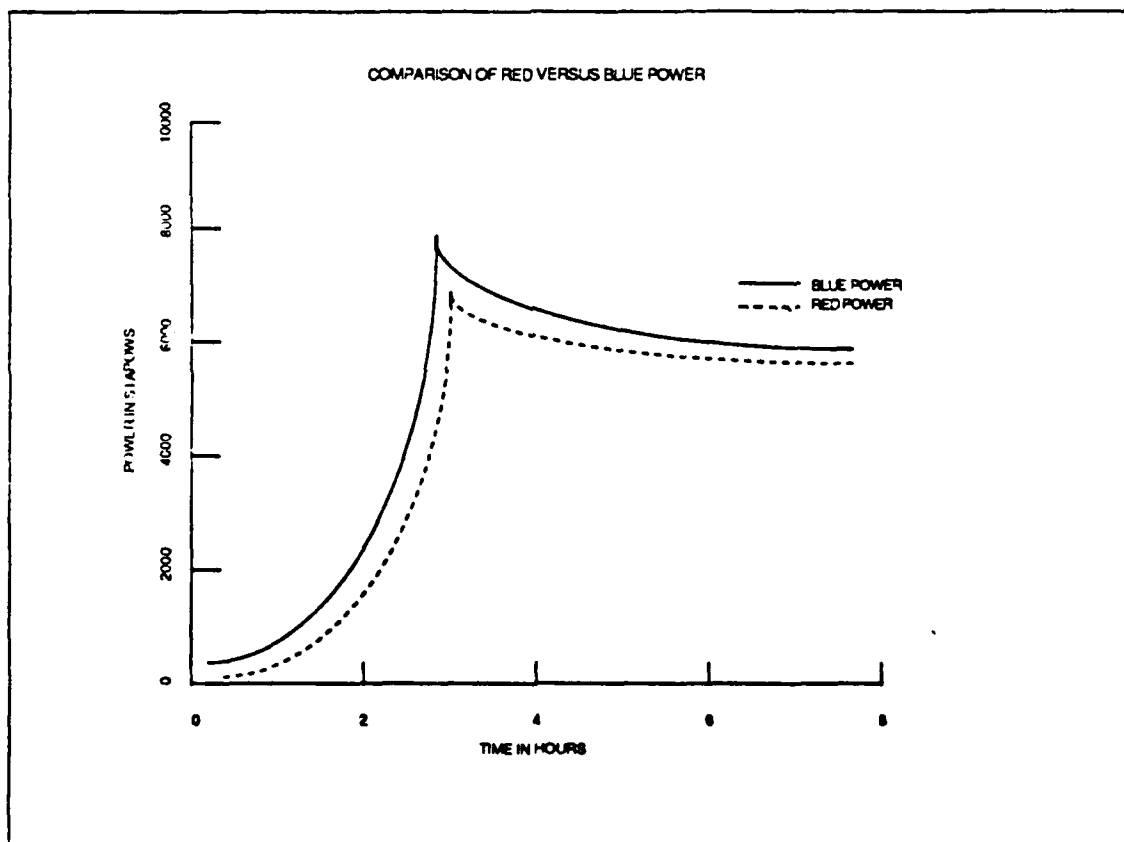

Figure 5.2 Power Curves Resulting from an Information Update at  $t_0$ .

TAR missions, shown in Table 4, are added to the scheduled reconnaissance events list to occur at times,  $t_3$ ,  $t_5$ , and  $t_{11}$  with specified mission<sup>11</sup> packages and information deadlines. Sequentially following the timeline, an initial mission feasibility check is performed by determining the difference in current perceived power levels between forces in the brigade's sector. The feasibility check does not reflect a SIP threshold violation and therefore indicates that the current plan, formulated at  $t_1$ , to actually commit  $x_1$  and  $x_2$  against  $y_3$  and  $y_4$  at time,  $t_{16}$ , which is the projected time of engagement, is feasible.

TABLE 4  
SCHEDULED RECONNAISSANCE EVENTS LIST

<i>Mission Time</i>	<i>Mission Package</i>	<i>NLT</i>
$t_2$	Z	$t_0$
$t_3$	X	$t_5$
$t_5$	Y	$t_7$
$t_{11}$	Z	$t_{12}$
$t_{13}$	Y	$t_{14}$

The logic involved in this "need for a decision" process is provided in Figures 5.3 and 5.4. The initial mission order input is received at (1). At this time the intelligence module is activated and must determine information requirements which is essentially a query of the perceived database (2). Information needs and gaps are identified, at such time the IEP (3a) forwards a request for additional information. An example of the composition of a request is as follows:

<sup>11</sup> Mission packages refer to the total sum of all collection platforms, sensors, and support systems that provide the responsiveness necessary to accomplish a collection mission. For this simple example let:

- a. X : a package best suited for sector search scanning,
- b. Y : a package that is sufficient for both sector search and point search, and
- c. Z : a package that is best suited for point (nodal) search.

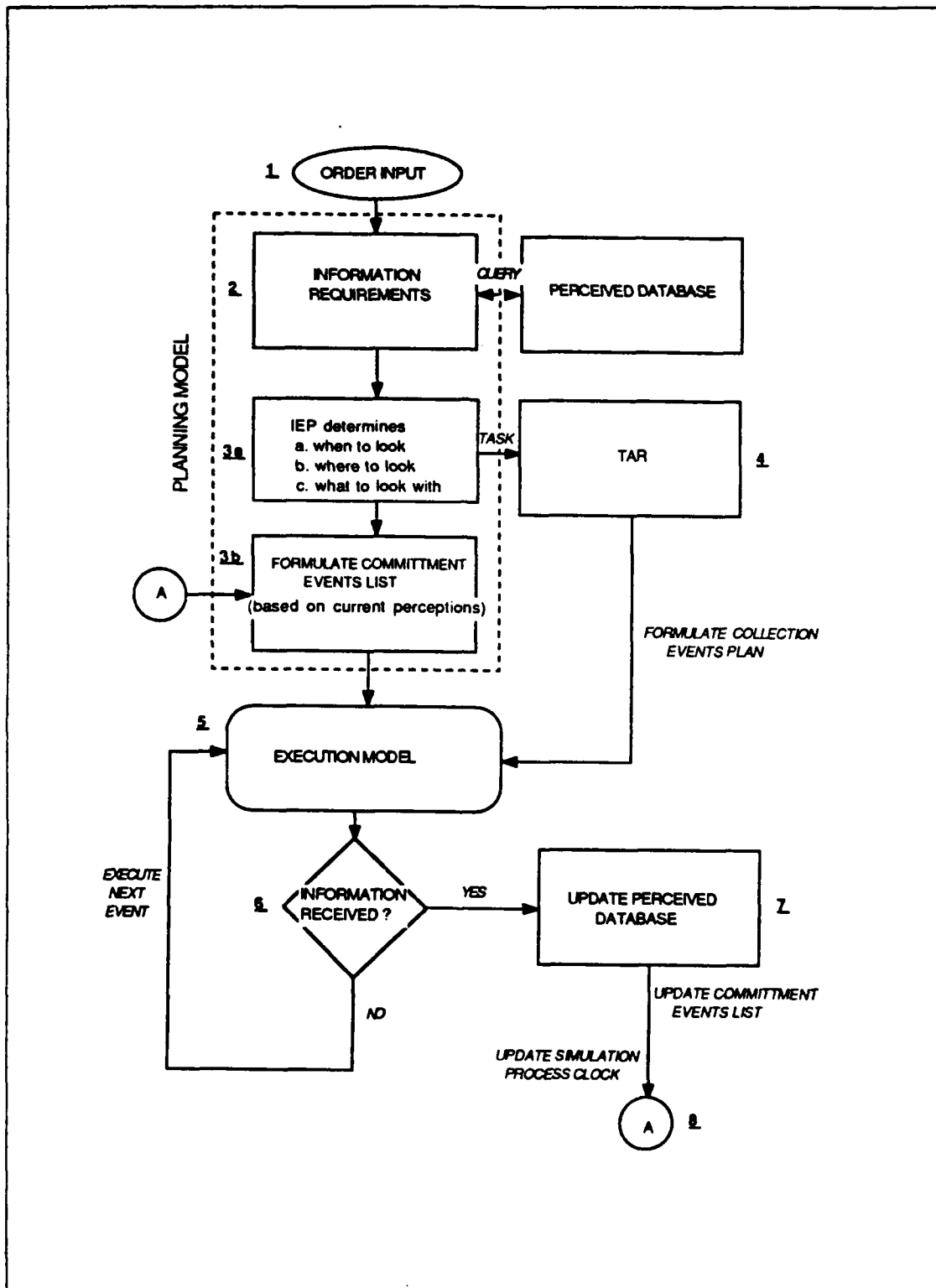

Figure 5.3 Process Flow.

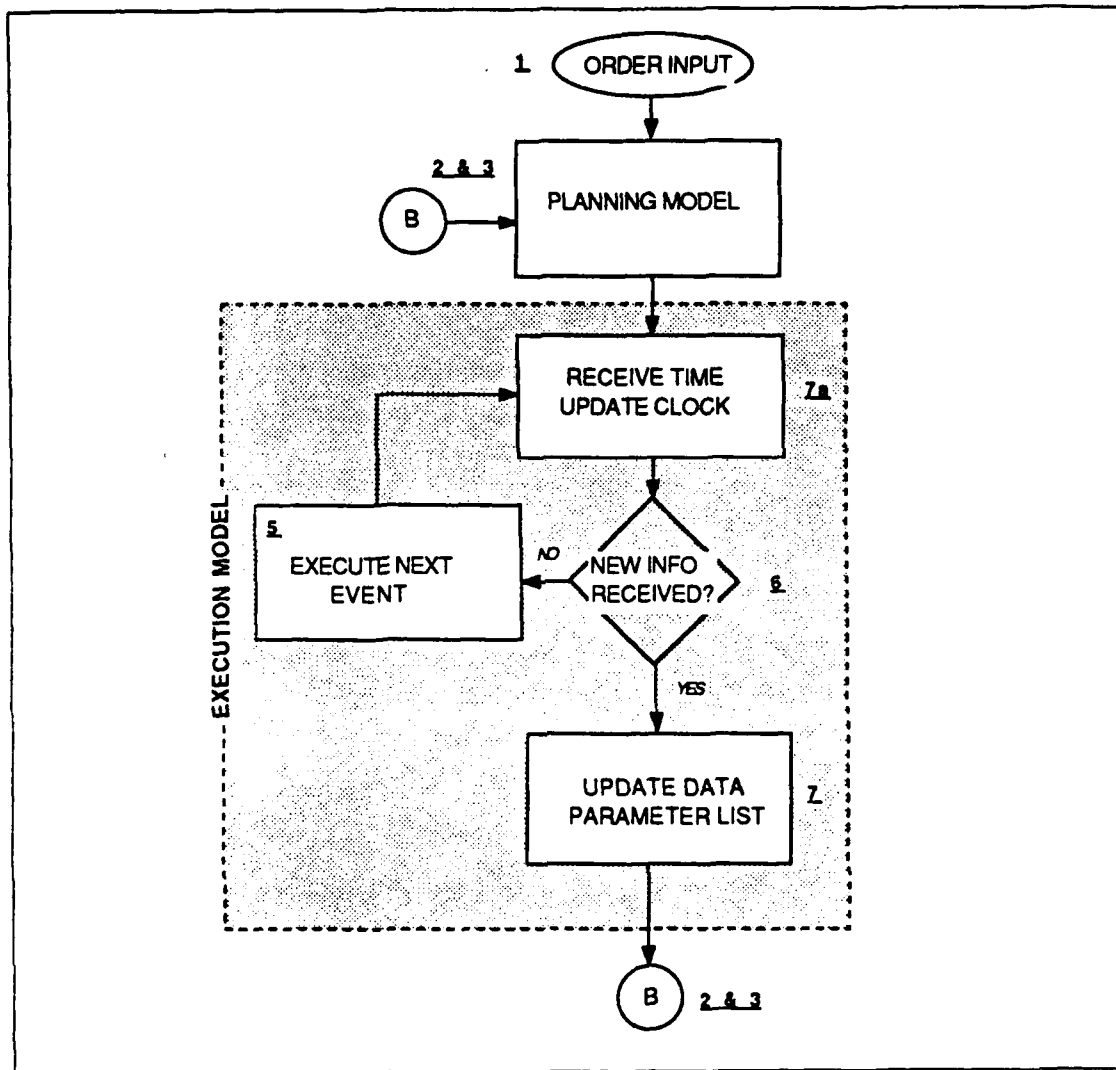

Figure 5.4 Process Flow Continued.

- Time entered system :  $t_1$  (i.e., this is a time tag to identify exactly when a request is forwarded)
- Request number : 24 (i.e., the 24<sup>th</sup> request in the collection management system)
- Area of interest : sectors #1 and #2 (refer to Figure 5.1, grid coordinates and node numbers will actually be used to identify targeted areas)
- Range to target : 55km (range to the estimated target location along a sequence of arcs)
- Coverage type : X (i.e., surveillance mode or area scan)

- Timing window : NET  $t_3$  and NLT  $t_5$  (i.e., due to the current perception state, information is required not earlier than time,  $t_3$ , and not later than time,  $t_5$ , in order for the brigade command level decision task to make combat decisions)

The intelligence module prepares SIP curves (3b) based on the information received during the query performed in (2). Feasibility of the resulting plan is checked and if feasible, the commitment events outlined in the plan are added to a master events list. At (4) the TAR model is invoked. The request generated in (3a) is validated and prioritized based on timing requirements of all existing missions waiting to be executed.

The procedure results in a scheduled reconnaissance event plan that is forwarded to the execution<sup>12</sup> model (5). While the execution model is running, information gathering activities generated at all levels result in an update to the perceived database (6). This update may or may not be in the form of newly acquired battlefield information due to the possible attrition of some collection platforms from simulated enemy anti-air activity. If no battlefield information is received then the execution model will continue to process events from the master events list (7). Finally, if new information is received at (8), the simulation clock is advanced to account for the time required to process the information. A flag from the perceived database causes the execution model to pause and existing plans are then checked to determine if new plans must be formulated.

### C. TIME, $T_3$

At time,  $t_3$ , the next TAR mission is executed from the scheduled reconnaissance events list resulting in new information being received at  $t_5$ . A visual presentation is provided in Figure 5.5. During execution the information was actually collected at  $t_4$  but the simulation clock process time must be advanced to account for the platform's transition back to a collection node and to physically process the collected information. The information consists of detection of a red airfield in sector #3 which immediately causes the planning model to be called.

The planning model is invoked resulting in the formulation of a new SIP curve. Assume that the blue force does not possess operational control of any assets capable of reaching and prosecuting the red airfield. Although the airfield is obviously an

---

<sup>12</sup>Note: the execution model continues to run while new plans are being formulated. At some time later these new plans may result in new orders to the execution model.

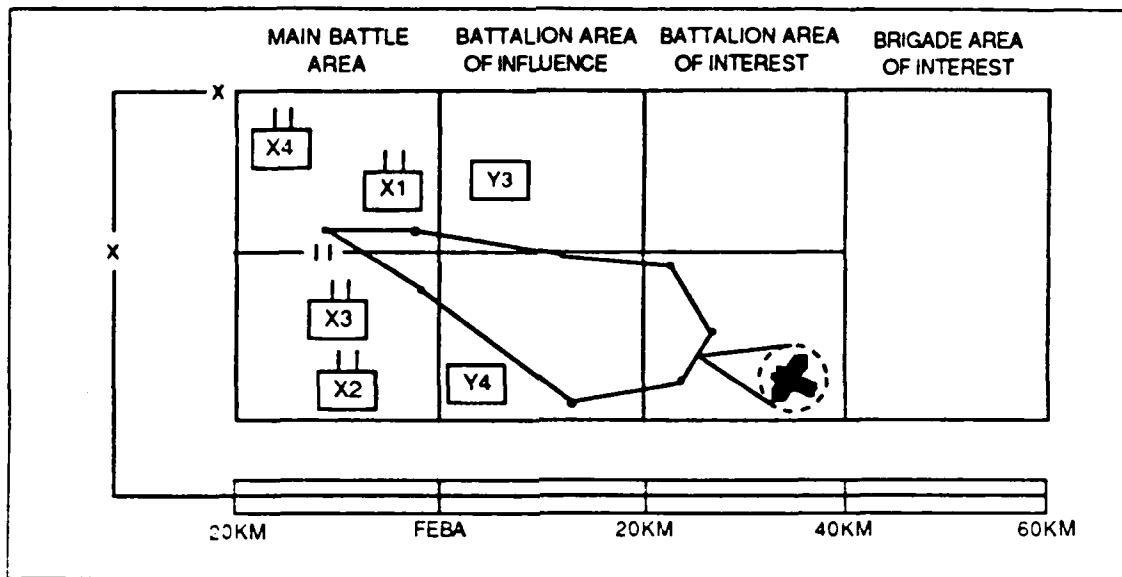

Figure 5.5 Perceived Situation at time  $t_5$ .

extremely high value target, the existing macro plan developed at  $t_1$  would remain in force as the current macro plan. The existing events list would remain unchanged while the commitment of assets is not redirected to prosecute this lucrative target.

#### D. TIME, $T_{12}$

At time,  $t_{12}$ , the planning model is again invoked resulting in the formulation of new SIP curves based on the newly acquired information (this information is a result of the  $t_8$  mission in which  $y_1$  and  $y_2$  are detected and identified). These new SIP curves indicate that the plan which committed tank battalions  $x_1$  and  $x_2$  initially at the FEBA against red first echelon regiments,  $y_3$  and  $y_4$ , and with uncommitted units  $x_3$ ,  $x_4$ , and  $x_5$  becomes infeasible 4.3 hours after the beginning of the decision period. The resulting point of infeasibility, shown in Figure 5.6, is a violation of the upper threshold value. The projected violation time corresponds to the estimated time of arrival of the most recently detected red second echelon units  $y_1$  and  $y_2$  (see Figure 5.7).

Courses of action are now developed to restore feasibility by first determining notification times for each entity through functional submodels. Notification times are used to generate all possible asset(i) to target(j) paired combinations. Fourteen resulting courses of action are generated of which six are feasible (see Table 5). The

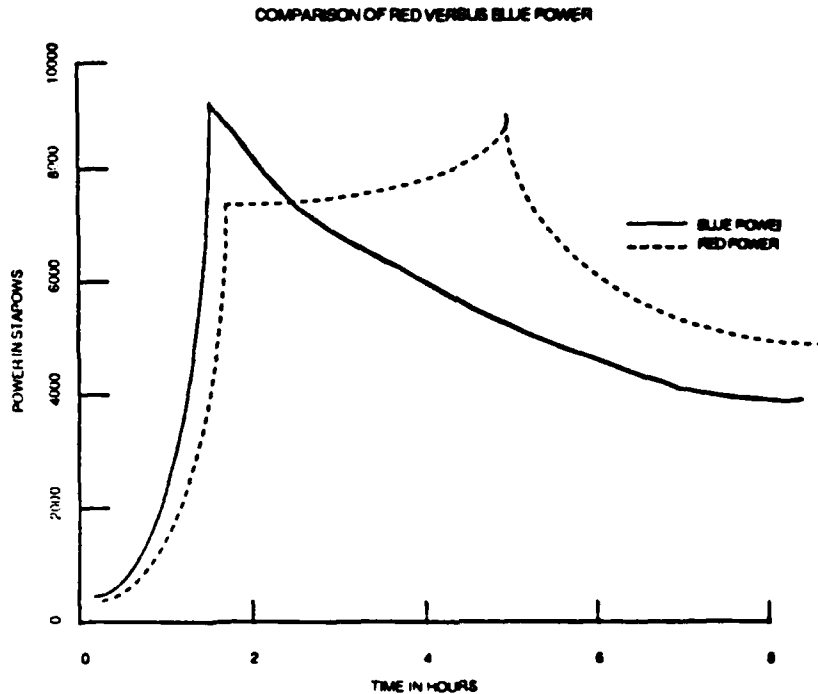

Figure 5.6 Power Curves Resulting from the Information Update at  $t_g$ .

feasible course of action which generates the maximum ratio of red power destroyed to blue power used is selected. The course of action selected is for artillery unit  $x_4$  to prosecute  $y_3$  with a time of engagement of 1.5 hours after the start of the decision period. The SIP curve resulting from this decision is shown in Figure 5.8.

Stepping back through the plan to check for feasibility, another violation is detected. It is projected to occur at 4.5 hours after the start of the decision period. Again feasible courses of action must be determined. It is noted here that the artillery unit is again considered for use in the development of courses of action. This represents that process in the real world of redirecting fires against an enemy target beyond the FEBA in order to attrit that unit prior to its arrival at the FEBA [Ref. 5, p. 58]. Two courses of action were developed during this iterative process of checking macro plan feasibility. Implementation of the perceived optimal course of action results in the SIP shown in Figure 5.9. Stepping back through the plan now does not produce any violations, therefore until such time when new information is received through collection efforts, the plan is feasible and is the current macro plan. The commitment events of the plan are listed in Table 6.

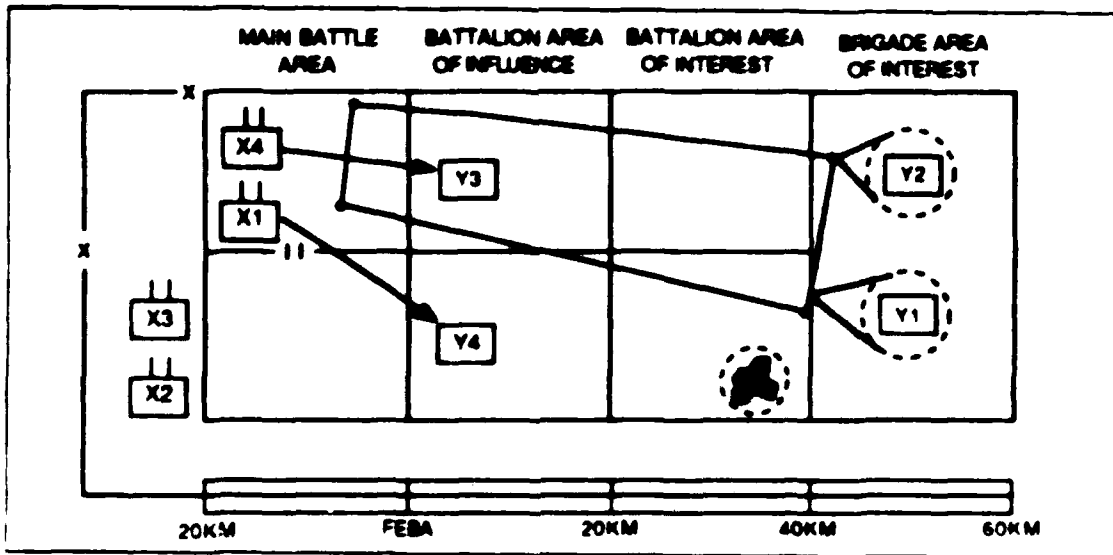

Figure 5.7 Perceived Situation at Time  $t_0$

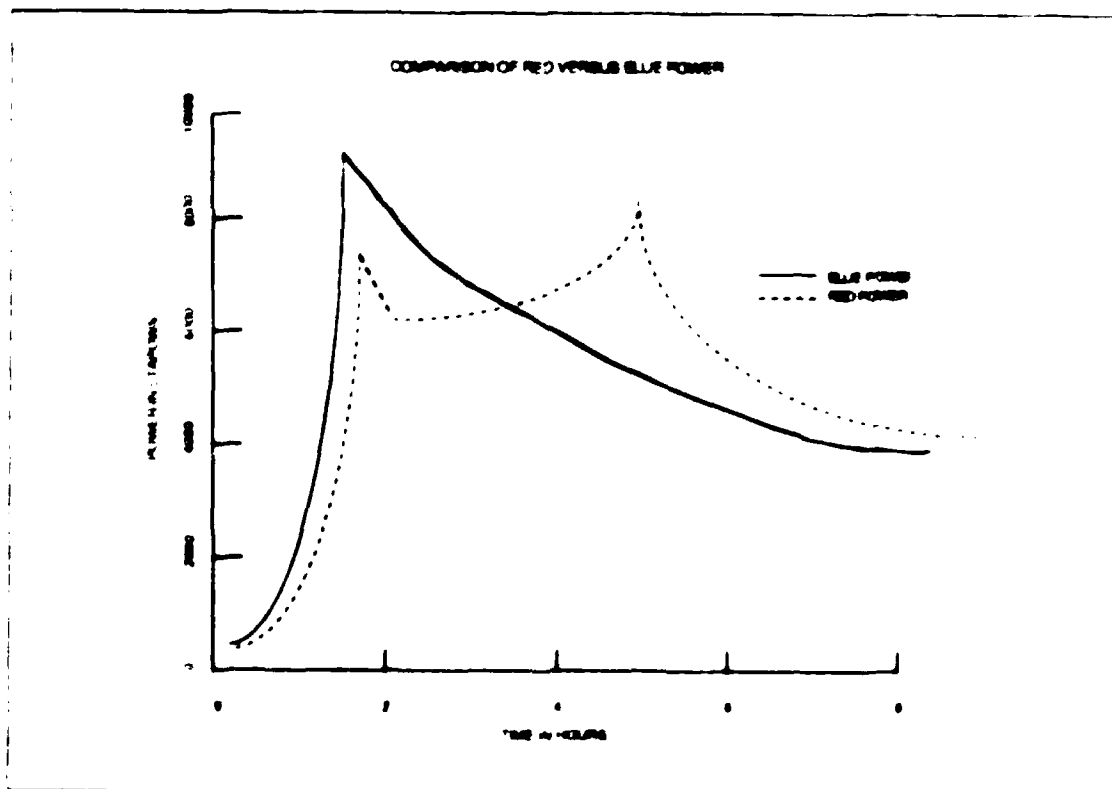

Figure 5.8 Second Iteration Power Curve resulting from the Information Update at time  $t_0$

**TABLE 5**  
**FEASIBLE COURSES OF ACTION GENERATED AT TIME,  $T_{12}$**

<i>Feasible course of action</i>	$t_{eng}$	$x_i$	$y_j$	<i>Power Ratio</i>
1	1.5 hrs.	$x_4$	$y_3$	57.4
2	1.5 hrs.	$x_4$	$y_4$	28.5
3	0.5 hrs.	$x_3$	$y_3$	57.4
4	0.5 hrs.	$x_3$	$y_4$	28.5
5	1.0 hrs.	$x_3$	$y_4$	57.4
6	1.5 hrs.	$x_3$	$y_4$	28.5

Where:

- $t_{eng}$  is the time of engagement.
- $x_i$  is a blue force entity.
- $y_j$  is a red force entity.
- Power ratio is the proportion of red power neutralized to blue power expended.

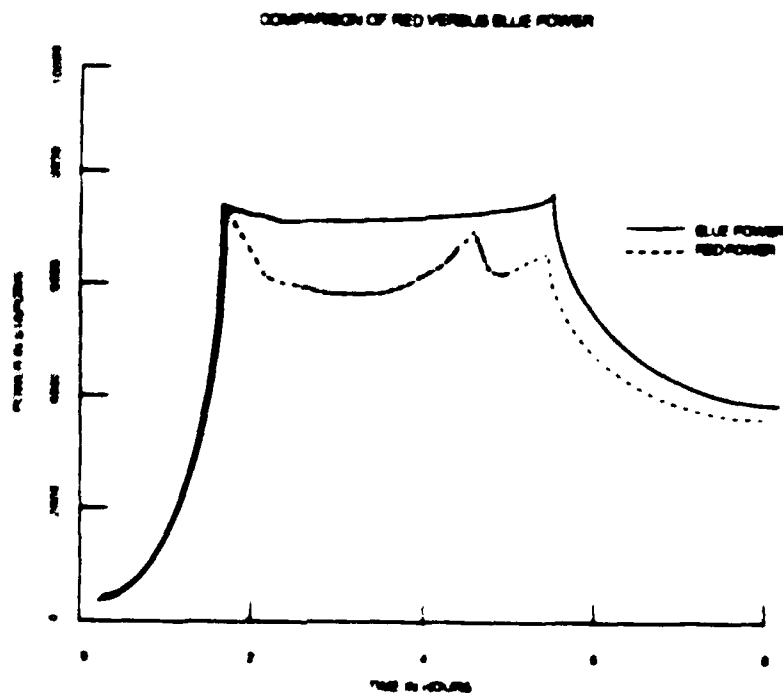

Figure 5.9. Third Iteration Power Curve resulting from the Information Update at time  $t_4$

### E. TIME, $T_{13}$

At time,  $t_{13}$ , a reconnaissance mission was executed, however no additional information was obtained. The macro plan generated after the perception database update at  $t_{12}$  remains as the current plan of operations. This plan may only be modified during the course of the decision period. This may occur when the brigade level decision task determines that achievement of the plan is not possible. The planning mode would be invoked using current perceptions to project red power and allocate the associated blue force resource requirements.

TABLE 6  
MACRO PLAN FOR EVENTS TO BEGIN AT TIME,  $T_{16}$

<i>Time</i>	<i>Event</i>
1.5 hours	$x_4$ fires on $y_3$
2.0 hours	commit $x_1$ to defend at the FEBA against $y_3$
2.0 hours	commit $x_2$ to defend at the FEBA against $y_4$
2.5 hours	$x_4$ fires on $y_2$
4.0 hours	commit $x_2$ to defend at the FEBA against $y_1$

### F. SUMMARY

This chapter has demonstrated the development of a macro plan by stepping through the perception generation procedure. These macro plans are formulated in ALARM using an iterative process of

1. determining initial mission feasibility.
2. developing initial feasible courses of action, and
3. selecting a course of action which restores feasibility for the duration of the decision period.

The final macro plan provides an output for the allocation and commitment of unit entities over time. This list of commitment events provides a detailed audit trail of the cause and effect relationships desired to support the analysis of the military combat decision process.

## VI. SUMMARY

### A. CONCLUSIONS

The purpose of this thesis was to explore some initial issues that must be addressed in order to imbed a credible model of reconnaissance operations within the Airland Research Model (ALARM). During the course of the research effort the objectives of identifying and describing attributes of reconnaissance operations, which in turn, provide updates to the perceived database were achieved. The document provides a description of the current conceptual design of the Airland Research Model and details the planning methodology utilized within the model. Background on the operational environment in which the model will operate, the connection between this work on reconnaissance operations, the perception generation process, and ALARM's planning scheme was provided. In addition, the following areas were addressed:

- 1) A description of the reconnaissance cycle which is the perception formulation process used to update the perceived database;
- 2) The structure of the Tactical Air Reconnaissance (TAR) model which is subdivided into a collection management and an information acquisition sub-models;
- 3) A description of the evolution and development of the perception database by walking through a sample scenario.

### B. FUTURE DIRECTIONS

There are several areas in the development of algorithms to support the integration of an airborne collection function that require additional research. These areas must be addressed before reaching the phase to begin coding the TAR model. First, the interface between the intelligence module and TAR requests must be further refined. It was stated that the intelligence estimate processor (IEP) will perform an inferencing function to determine where to vector the collection platforms. Current U.S. Army doctrine states that decision templates will be used to predict these enemy courses of action. A methodology for abstracting this intelligence procedure is required.

Second, a means for modelling the act of communicating all acquired information back to specific intelligence collection nodes must be developed. The procedure should address the differences between information, that which is used to formulate perceptions, and data, that which is the abstract "information form" transmitted along

the modelled communications medium. Note that information content is not necessarily equivalent to the amount of data transmitted. Use of a communications network may satisfy this requirement with nodes representing information sources and sinks while arcs represent the various transmission rates, measured in bits per unit time.

The third area requiring work is the implementation of an initial network system to model the flight paths of the collection platforms. Research in this area should focus on a procedure to assign alternative ingress and egress routes from a dynamically generated air-transportation network. An additional dimension required in this area is to develop the measures of effectiveness associated by possibly contrasting various network flight profiles.

The detection model to be used in ALARM is yet to be precisely defined. An issue that must be evaluated before the necessary detection algorithms can be developed is the determination of an appropriate method of target aggregation within mobility corridors. This issue concerns the derivation of probabilities, per reconnaissance mission, of detecting a particular type of target entity as a function of the entity's location on the terrain network. In addition, this area requires clarification on how to determine the fraction of total target entities, in a given search path, detected during the execution of a given collection mission.

The final area identified requiring additional research goes beyond the utilization of collection platforms in the model. This area applies to the "other" airborne type platform functions to be called upon by the air asset decision task. These platforms will perform the air tasks required in ALARM such as close air support or battlefield air interdiction. The generalized value system or some other means must be applied to these airborne combat functions in order to assess the tradeoffs and the utility associated with formulating macro plans that specify either the allocation of these air entities to be committed in offensive or defensive roles over a given decision period.

## APPENDIX A TAR VARIABLES

### 1. ATTRIBUTES THAT ACCOMPANY EACH COLLECTION PLATFORM

- a. **AIR WARNING(X)** = location of known enemy platforms that are in the vicinity of active collection platform X.
- b. **COMMUNICATE(X)** = the method of transmitting the imaging information back to a command node. This determines whether or not a real-time communications link is in place to control the advance rate of the simulation clock.
- c. **EGRESS ROUTE(X)** = the node numbers corresponding to the air route to be flown from the collection site.
- d. **ENEMY(X)** = list of enemy entities which have been detected by platform X along with location, size, and rate of advance at the time of detection.
- e. **FILM(X)** = the amount of unexposed film capacity remaining on platforms equipped with photographic imaging sensors.
- f. **FUEL(X)** = the amount of fuel currently on platform X.
- g. **GROUND WARNING(X)** = location of known enemy entities on the terrain network that can potentially affect the collection mission of collector X. This attribute can be utilized in the procedure to determine routes minimizing exposure times.
- h. **INGRESS ROUTE(X)** = the node numbers corresponding to the air route to be traversed to the designated collection area.
- i. **TARGET LOCATION(X)** = the detected target locations by ground network node number.
- j. **PLATFORM POSITION(X)** = the three dimensional (x,y,z) battlefield position of the collection platform.
- k. **REQUEST(X)** = node numbers contained in the request over which the platform is to collect information.
- l. **SENSOR\_ON(X)** = the target acquisition system employed on platform X.
- m. **STATUS PLATFORM(X)** = the current status of a collection platform (i.e. dead, unavailable, on mission).
- n. **STATUS SENSOR(X)** = the status of an imaging sensor system (i.e. dead, unavailable, on mission).
- o. **TIME ON TARGET(X)** = the collection search type to be performed (point or area search).
- p. **TYPE(X)** = the type of platform used (each type has different range and speed limitations).

### 2. OTHER RADIONOMETRIC AND RADAR VARIABLES TO CONSIDER WHEN MODELLING SENSOR-TARGET ACQUISITION

**a. Radiometric variables required to model the imaging process**

1. **Absorptance** - the fraction of power per unit area incident upon an entity's surface that is absorbed by a sample placed in the path of incident light.
2. **Absorptivity** - the absorptance per unit pathlength through a medium.
3. **Emissance** - the fraction of radiant emittance of an entity's surface relative to the emittance from an ideal surface.
4. **Irradiance** - the power per unit area incident upon a perceived surface.
5. **Power** - energy per unit time.
6. **Radiance** - radiant power per unit solid angle per unit area of source projected normal to the solid angle.
7. **Radiant emittance** - the power per unit area radiated from an entity's surface.
8. **Radiant intensity** - radiant power per unit solid angle from a point source (platform).
9. **Reflectance** - the fraction of irradiance that is reflected from an ideal surface.
10. **Transmittance** - the fraction of irradiance that is transmitted through a sample placed in the path of incident light.

**b. Basic radar variables required to model radar acquisition**

1. **Azimuth definition** - the degree of accuracy to which the radar can measure azimuth.
2. **Azimuth resolution** - the ability of the radar to separate two targets close in azimuth at approximately the same range.
3. **Beamwidth** - the narrowness of the antenna beam.
4. **Pulse duration** - the time that the radar is transmitting RF energy
5. **Pulse repetition time** - the time required for a complete transmission cycle.
6. **Pulse repetition frequency** - the number of pulses per second that the radar transmits.
7. **Recovery time** - the time immediately following transmission time, during which the receiver is unable to process target returns.
8. **Rest time** - the time between the end of one transmitted pulse and the beginning of the next.
9. **Listening time** - the time the receiver can process target echoes.
10. **Duty cycle** - the ratio of the time the transmitter operates to the time it could operate in a given transmission cycle.
11. **Peak power** - maximum power output during transmission time.
12. **Average power** - peak power distributed over the pulse repetition time.
13. **Range definition** - the degree of accuracy to which the radar can measure range
14. **Range resolution** - the ability of the radar to separate two targets close in range at approximately the same azimuth.

APPENDIX B  
PERCEPTION GENERATION TIMELINE

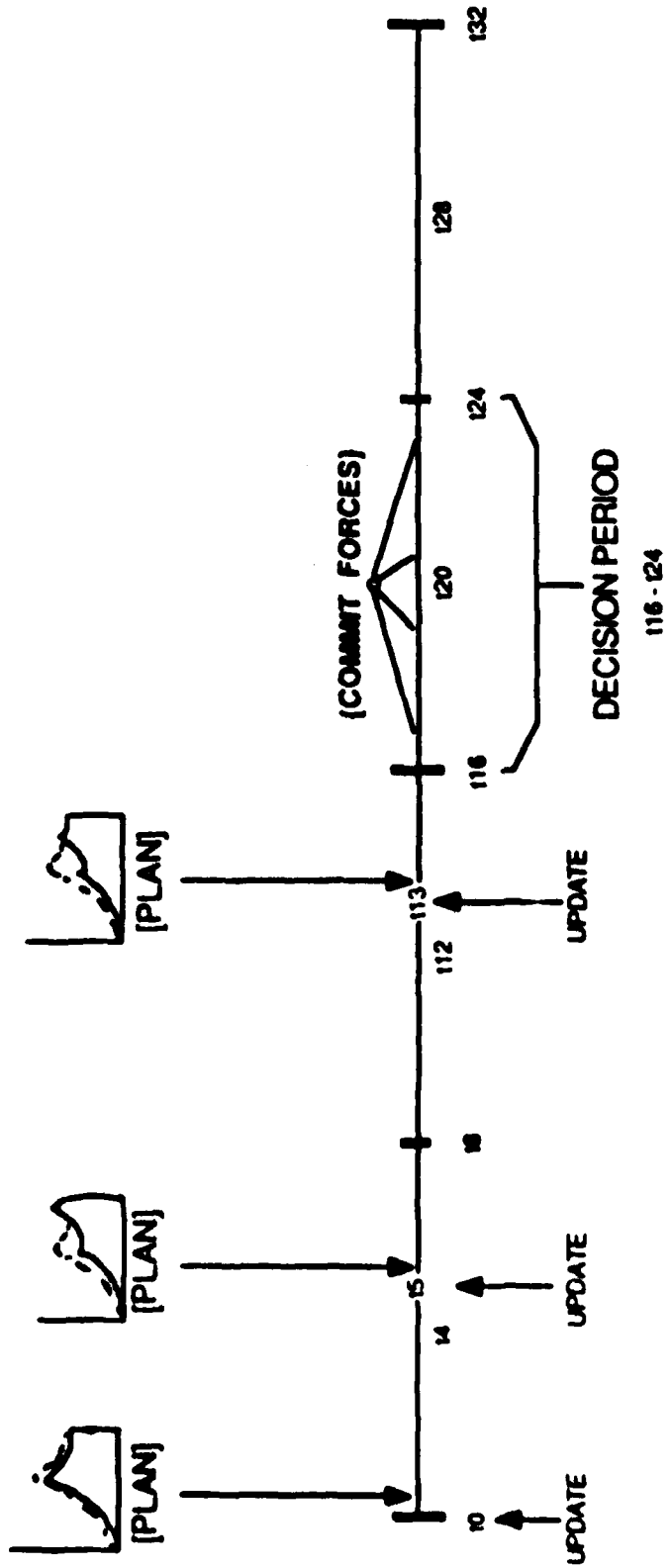

Figure B.1 Process Timeline with a Decision Period from t<sub>16</sub> to t<sub>24</sub>.

## LIST OF REFERENCES

1. Sun Tzu, *The Art of War, translated and with an introduction by Samuel B. Griffith*, London, England: Clarendon Press, 1963.
2. Hartman, J.K., Parry, S.H., Shoenstadt, A.L., *AirLand Research Model*, paper presented to the Military Operations Research Society, Naval Postgraduate School, Monterey, CA, March 1986.
3. *Preliminary Conceptual Design for the AirLand Advanced Research Model*, Department of Operations Research, Naval Postgraduate School, Monterey, CA, August 1986.
4. Kilmer, R., *Using the Generalized Value System and Future State Decision Making*, M.S. Thesis, Naval Postgraduate School, Monterey, CA, March 1986.
5. Fletcher, D.L., *Models for Avenues of Approach Generation and Planning Process for Ground Combat Forces*, M.S. Thesis, Naval Postgraduate School, Monterey, CA, September 1986.
6. Starry, D.A., "Extending the Battlefield," *Military Review*, Volume LXI, Number 3, pp. 31 - 50, March 1981.
7. U. S. Department of the Air Force, AFM 2-1, *Basic Aerospace Doctrine of the USAF*, Washington, D.C., 16 March 1984.
8. Smith, G.L., *Foundations of the Intelligence Module of the AirLand Research Model*, M.S. Thesis, Naval Postgraduate School, Monterey, CA, September 1986.
9. Hartman, J.K., *Lecture Notes on High Resolution Combat Modelling*, class notes, Naval Postgraduate School Monterey, CA, June 1985.
10. Baker, R., Friedman, R.S., Kennedy, W.V., Miller, D., *Intelligence Warfare*, N.Y., N.Y.: Crescent Books, 1983.
11. Gunston, B., *An Illustrated Guide to Spy Planes and Electronic Warfare Aircraft*, N.Y., N.Y.: Arco Publishing, 1983.
12. U. S. Army Command and General Staff College, Field Circular 100-15, *Corps Operations*, Fort Leavenworth, KS, 1 March 1984.

## BIBLIOGRAPHY

Hartman, James K., *Lecture Notes on Aggregated Combat Modelling*, class notes, Naval Postgraduate School Monterey, CA, June 1985.

Headquarters Department of the Army, *Field Manual 34-1, Intelligence and Electronic Warfare Operations*, Washington, D.C., 5 May 1986.

Headquarters Department of the Army, *Field Manual 34-3, Intelligence Analysis*, Washington, D.C., 13 January 1986.

Headquarters Department of the Army, *Field Manual 100-5, Operations*, Washington, D.C., 5 May 1986.

McLaughlin, Joseph R., *The Extension of Unit Allocation and Counter mobility Planning Algorithms in the AirLand Research Model*, M.S. Thesis, Naval Postgraduate School, Monterey, CA, March 1986.

Parry, S.H., Schoenstadt, A.L., *Toward an Axiomatic Generalized Value System*, Technical Report, Naval Postgraduate School, Monterey, CA, May 1986.

U. S. Air Force Tactical Air Command, *Tactical Air Command Manual 2-1*. Langley Air Force Base, Virginia, 15 April 1978.

U. S. Air Force Tactical Air Command, *Tactical Air Command Pamphlet 50-26. Joint Operational Concept. Joint Attack of the Second Echelon (J-SAK)*, Langley Air Force Base, Virginia, 13 December 1982.

U. S. Army Command and General Staff College, *Field Circular 101-55. Corps and Division Command and Control*, Fort Leavenworth, KS, 28 February 1985.

## INITIAL DISTRIBUTION LIST

	No. Copies
1. Defense Technical Information Center Cameron Station Alexandria, Virginia 22304-6145	2
2. Library Code 0142 Naval Postgraduate School Monterey, California 93943-5002	2
3. Naval Postgraduate School Code 55Py Attention: Dr. Samuel H. Parry Monterey, California 93943-5000	6
4. Naval Postgraduate School Code 39 Attention: Dr. Michael Sovereign Monterey, California 93943-5000	4
5. Levy Watkins Learning Center Alabama State University 915 South Jackson Street Montgomery, Alabama 36195-5000	2
6. Director U.S. Army Models Management Office Combined Arms Center Attention: COL Ken Wiersma Fort Leavenworth, Kansas 66027-5000	1
7. AFOTEC OAY Attention: Capt. Raymond D. Harris Jr. Kirtland AFB, New Mexico 87117-7001	2
8. USASPACE CECOM AMSEL - SEI - F Ft. Monmouth, New Jersey 07703-5000	2
9. AFIT CISK Attention: MAJ Raymond C. Harlan Wright-Patterson AFB, Ohio 45433-6583	2
10. Deputy Undersecretary of the Army for Operations Research Room 2L261, Pentagon Washington, D.C. 20310-5000	1
11. Director of Research U.S. Army TRADOC Analysis Command Attention: Mr. Warren Olsen White Sands Missile Range, New Mexico 88002-5000	1
12. Commander U.S. Army TRADOC Analysis Command Attention: Mr. Reed Davis Fort Leavenworth, Kansas 66027-5000	1
13. Director U.S. Army Concepts Analysis Agency Attention: Mr. F. B. Vandinger III Bethesda, Maryland 20814-5000	1

- 14. Bell Hall Library  
U.S. Army Combined Arms Center  
Fort Leavenworth, Kansas 66027-5000 1
- 15. Director  
Studies and Analysis Directorate  
Headquarters U.S. Army TRADOC  
Attention: COL Tony Brinkley  
Fort Monroe, Virginia 23651-5000 1
- 16. Department of Operations Sciences  
AFIT ENS  
Attention: MAJ Dan Reven  
Wright-Patterson AFB, Ohio 45433-6583 1

END

7-87

Ditic