



DTIC FILE COPY

AD-A181 453

SULFUR HEXAFLUORIDE AS A TRACER FOR THE VERIFICATION OF WASTE DESTRUCTION LEVELS IN AN INCINERATION PROCESS

C.L. PROCTOR II, M.C. BERGER, D.L. FOURNIER JR., S. ROYCHOUDHURY

UNIVERSITY OF FLORIDA
COMBUSTION LABORATORY
MECHANICAL ENGINEERING DEPARTMENT
GAINESVILLE, FL 32611

APRIL 1987

FINAL REPORT

MAY 1984 - APRIL 1986

DTIC ELECTE
S JUN 19 1987 D
D

APPROVED FOR PUBLIC RELEASE: DISTRIBUTION UNLIMITED



ENGINEERING & SERVICES LABORATORY
AIR FORCE ENGINEERING & SERVICES CENTER
TYNDAL AFB, FLORIDA 32403

UNCLASSIFIED

SECURITY CLASSIFICATION OF THIS PAGE

AD A181 453

REPORT DOCUMENTATION PAGE

1. REPORT SECURITY CLASSIFICATION Unclassified			1b. RESTRICTIVE MARKINGS			
2a. SECURITY CLASSIFICATION AUTHORITY			3. DISTRIBUTION/AVAILABILITY OF REPORT Approved for public release Distribution unlimited			
2b. DECLASSIFICATION/DOWNGRADING SCHEDULE						
4. PERFORMING ORGANIZATION REPORT NUMBER(S)			5. MONITORING ORGANIZATION REPORT NUMBER(S) ESL-TR-86-47			
6a. NAME OF PERFORMING ORGANIZATION University of Florida Combustion Laboratory		6b. OFFICE SYMBOL (If applicable)	7a. NAME OF MONITORING ORGANIZATION Air Force Engineering and Services Center			
6c. ADDRESS (City, State and ZIP Code) Mechanical Engineering Department Gainesville FL 32611			7b. ADDRESS (City, State and ZIP Code) HQ AFESC/RDVS Tyndall AFB FL 32403			
8a. NAME OF FUNDING/SPONSORING ORGANIZATION		8b. OFFICE SYMBOL (If applicable)	9. PROCUREMENT INSTRUMENT IDENTIFICATION NUMBER -83-C- F08635-0136			
8c. ADDRESS (City, State and ZIP Code)			10. SOURCE OF FUNDING NOS.			
			PROGRAM ELEMENT NO 62601F	PROJECT NO 1900	TASK NO 70	WORK UNIT NO 35
11. TITLE (Include Security Classification) Sulfur Hexafluoride as a Tracer for the Verification of Waste Destruction Levels in an Incineration Process						
12. PERSONAL AUTHOR(S) C.L. Proctor II, M.C. Berger, D.L. Fournier Jr., S. Roychowdhury						
13a. TYPE OF REPORT Final		13b. TIME COVERED FROM May 84 to Apr 86		14. DATE OF REPORT (Yr., Mo., Day) April 1987		15. PAGE COUNT 94
16. SUPPLEMENTARY NOTATION Availability of this report is specified on reverse of front cover.						
17. COSATI CODES			18. SUBJECT TERMS (Continue on reverse if necessary and identify by block number)			
FIELD	GROUP	SUB GR.	Hazardous waste, incineration; destruction, removal efficiency; surrogates; tracers; industrial boilers, hazardous materials			
121	02					
1107	04					
19. ABSTRACT (Continue on reverse if necessary and identify by block number) The use of sulfur hexafluoride (SF ₆) as a tracer for the verification of hazardous waste destruction levels in an incineration process is discussed. This study determined the relationships between fuel flow, air flow, temperature, and mixing, and the destruction removal efficiency (DRE) of SF ₆ in a laboratory natural gas burner. The motivation for the study was the need to establish fundamental relationships which could be used in later studies concerned with using SF ₆ as a tracer in combustion processes. SF ₆ was mixed with natural gas and burned in a turbulent diffusion flame, typical industrial boiler flames. The SF ₆ DRE was determined for various air and fuel flow rates, and for two different burner mixing conditions. Laboratory samples of three compounds typically found in Air Force hazardous wastes were also vaporized and burned. The compounds were toluene, benzene, and trichloroethylene. The DREs of these compounds were greater than the DRE of SF ₆ when burned under the same conditions. An empirical relationship was developed, relating the DRE of SF ₆ to a characteristic time, based on fuel flow and adiabatic flame temperature, and an empirical rate constant, based on the adiabatic flame temperature. (Continued on reverse)						
20. DISTRIBUTION/AVAILABILITY OF ABSTRACT UNCLASSIFIED, UNLIMITED <input checked="" type="checkbox"/> SAME AS RPT <input type="checkbox"/> DTIC USERS <input type="checkbox"/>			21. ABSTRACT SECURITY CLASSIFICATION UNCLASSIFIED Keywords: ✓			
22a. NAME OF RESPONSIBLE INDIVIDUAL SURENDRA B. JOSHI			22b. TELEPHONE NUMBER (Include Area Code) (904) 283-4235		22c. OFFICE SYMBOL RDVS	

relationships will provide a starting point for analyzing data from future studies in bench-scale and full-scale incineration systems.

PREFACE

This report was prepared by the University of Florida Combustion Laboratory, Mechanical Engineering Department, Gainesville, Florida 32611, under contract Number F08635-0136, Task 84-03, for the Air Force Engineering and Services Center, Engineering and Services Laboratory (AFESC/RDVS), Tyndall AFB, Florida 32403.

This report summarizes work done at the University of Florida Combustion Laboratory between May 1984 and April 1986. The work was performed under the direction of Dr C.L. Procter, II, Principal Investigator. The contributions of M.L. Berger, D.L. Fournier, Jr., and S. Roychoudhury are acknowledged in the completion of this report. The HQ AFESC/RDVS project officer was Mr Surendra B. Joshi.

This report has been reviewed by the Public Affairs (PA) Office and is releasable to the National Technical Information Service (NTIS). At NTIS, it will be available to the general public, including foreign nationals.

This technical report has been reviewed and is approved for publication.

Surendra B. Joshi

SURENDRA B. JOSHI
Project Officer

Kenneth T. Denblyker

KENNETH T. DENBLEYKER, Maj, USAF
Chief, Environmental Sciences Branch

Robert F. Olfenbuttel

ROBERT F. OLFENBUTTEL, Lt Col, USAF, BSC
Chief, Environics Division

James R. Van Orman

JAMES R. VAN ORMAN
Deputy Director of Engineering and
Services Laboratory



Accession For		
NTIS CRA&I		<input checked="" type="checkbox"/>
DTIC TAB		<input type="checkbox"/>
Unannounced		<input type="checkbox"/>
Justification		
By		
Distribution /		
Availability Codes		
Dist	Avail and/or	
A-1		

TABLE OF CONTENTS

Section	Title	Page
I	INTRODUCTION.....	1
	A. OBJECTIVE.....	1
	B. BACKGROUND.....	1
	C. SCOPE.....	2
II	FACTORS AFFECTING DESTRUCTION REMOVAL EFFICIENCY.....	3
	A. DESTRUCTION REMOVAL EFFICIENCY.....	3
	B. TIME AND TEMPERATURE CONSIDERATIONS.....	4
	C. MIXING.....	4
	D. OTHER CONSIDERATIONS.....	7
III	USE OF TRACERS.....	8
	A. DESIRABLE CHARACTERISTICS OF A TRACER.....	8
	B. CANDIDATE TRACERS.....	10
	C. SULFUR HEXAFLUORIDE AS A TRACER.....	11
	D. RATIO TECHNIQUE.....	12
	E. OTHER INDICATORS OF DRE.....	12
	F. SELECTION OF A TRACER.....	13
IV	EXPERIMENTAL APPROACH.....	14
	A. TRACER-MIXING SYSTEM.....	14
	B. WASTE-MIXING SYSTEM.....	16
	C. BURNER DESIGN.....	16
	D. EXHAUST SYSTEM.....	19
	E. EXHAUST SAMPLING SYSTEM.....	19
	F. PHASE 1: SULFUR HEXAFLUORIDE EXPERIMENTAL PROCEDURE.....	22
	G. PHASE 2: SULFUR HEXAFLUORIDE AND SURROGATE WASTES PROCEDURE.....	27
V	ANALYSIS AND RESULTS.....	32
	A. PHASE 1 DATA ANALYSIS.....	32
	1. Initial Analysis.....	32
	2. Problems With Air Leaks.....	34
	3. Calculation of Adiabatic Flame Temperature.....	34
	B. PHASE 1 RESULTS.....	36
	1. Effects of Flow Rate.....	36
	2. Carbon Monoxide Emissions and Equivalence Ratio.....	36

TABLE OF CONTENTS
(Continued)

Section	Title	Page
	3. Temperature Effects.....	36
	4. Combined Time and Temperature Effects.....	49
	5. Review of Phase 1 Results.....	57
C.	PHASE 2 DATA ANALYSIS.....	63
	1. Initial Analysis.....	63
	2. Problems With Waste Detection.....	63
D.	PHASE 2 RESULTS.....	64
	1. Mixing.....	64
	2. Destruction Removal Efficiency.....	64
VI	CONCLUSION.....	67
	A. REVIEW OF RESULTS.....	67
	B. SULFUR HEXAFLUORIDE AS A TRACER.....	67
	C. SULFUR HEXAFLUORIDE AND MIXING.....	68
	D. PRACTICAL APPLICATIONS.....	68
VII	RECOMMENDATIONS.....	69
	A. IMPROVING PHASE 2 OF THE EXPERIMENT.....	69
	B. TRIALS IN FULL-SIZED INCINERATORS AND BOILERS.....	69
	C. DUAL TRACER TECHNIQUE.....	70
	D. MIXING RATE.....	70
	E. INCINERATION OF CHLORINATED COMPOUNDS.....	70
APPENDIX		
A.	PROGRAM TO ANALYZE PHASE 1 SF ₆ DATA.....	71
B.	SUBROUTINE STOICH.....	74
C.	SUBROUTINE TADIAB.....	77
D.	PROGRAMS USED FOR PHASE 2.....	80
E.	SAMPLE DATA.....	85
	REFERENCES.....	90

LIST OF FIGURES

Figure	Title	Page
1	Incinerability Curves.....	5
2	Incinerability Curves With Tracers.....	9
3	Gas-Handling System Used for SF ₆	15
4	Gas-Handling System Used for the Surrogate Wastes.....	17
5	Burner and Exhaust System.....	18
6	Photograph of Flame.....	20
7	Temperature Measurement Locations.....	21
8	Gas-Sampling System.....	23
9	CO/O ₂ -Sampling System.....	24
10	Gas Chromatograph Calibration Curve for SF ₆ in Phase 1.....	26
11	Gas Chromatograph Calibration Curve for SF ₆ in Phase 2.....	29
12	Gas Chromatograph Calibration Curve for Trichloroethylene.....	30
13	Calculated vs. Measured Oxygen.....	35
14	DRE vs. Air Flow.....	37
15	DRE vs. Fuel Flow.....	38
16	DRE vs. Total Flow.....	39
17	DRE vs. Carbon Monoxide.....	40
18	DRE vs. Equivalence Ratio.....	41
19	DRE vs. Temperature at Location 10.....	42
20	DRE vs. Temperature at Location 15.....	43
21	DRE vs. Adiabatic Flame Temperature.....	44
22	Temperature Profile; Minimum Air, Minimum Fuel.....	45

LIST OF FIGURES
(Continued)

Figure	Title	Page
23	Temperature Profile; Maximum Air, Minimum Fuel.....	46
24	Temperature Profile; Minimum Air, Maximum Fuel.....	47
25	Temperature Profile; Maximum Air, Maximum Fuel.....	48
26	DRE vs. Characteristic Time (based on total flow).....	51
27	Rate Constant (based on total flow) vs. Adiabatic Flame Temperature.....	53
28	DRE vs. Characteristic Time (based on fuel flow).....	54
29	Rate Constant (based on fuel flow) vs. Adiabatic Flame Temperature.....	55
30	$-\ln(1 - \text{DRE})$ vs. Rate Constant * Characteristic Time (based on fuel flow).....	56
31	Actual vs. Predicted DRE.....	58
32	Rate Constant (based on fuel flow) vs. $1/(\text{Adiabatic Flame Temperature})$	59
33	$-\ln(1 - \text{DRE})$ vs. Rate Constant (based on $1/\text{adiabatic flame temperature}$) * Characteristic Time (based on fuel flow).....	60
34	Profile of DRE Measurements.....	62
35	Rate Constant vs. Adiabatic Flame Temperature With Flame Holder Diameters of 1.27 cm and 2.54 cm.....	65
36	$-\ln(1 - \text{DRE})$ vs. Mixing Rate (based on SF ₆ data) * Characteristic Time, for Sulfur Hexafluoride, Benzene, and Trichloroethylene.	66

SECTION I

INTRODUCTION

A. OBJECTIVE

The objective of this research was to investigate the use of sulfur hexafluoride (SF_6) as a tracer for the verification of waste destruction levels in an incineration process. The effects of the fundamental combustion parameters of fuel flow, air flow, and mixing on SF_6 destruction levels were studied. The destruction levels of SF_6 were compared with the destruction levels of four surrogate hazardous wastes in a laboratory-scale natural gas burner. The surrogate wastes were benzene, toluene, trichloroethylene, and methylene chloride.

B. BACKGROUND

The disposal of hazardous wastes is a serious environmental problem. Incineration is known to effectively destroy many combustible and partially combustible wastes. Many wastes are suitable for cofiring with conventional fuels in industrial boilers. In fact, many wastes are suitable for use as fuels. Incineration of wastes in industrial boilers reduces transportation costs and fuel requirements, while simultaneously destroying the waste.

The EPA will soon require that both boilers and incinerators demonstrate through test burns that they can meet EPA regulations, which require a 99.99 percent destruction removal efficiency (DRE) for each waste. Test burns are expensive and the testing procedures are subject to large uncertainties. Furthermore, once a unit is approved for waste incineration, there is no provision for constant exhaust monitoring to insure effective operation. These two factors have been partly responsible for keeping incineration from becoming a more widely used waste disposal option.

The Air Force, like private industry, generates hazardous wastes and is considering cofiring the wastes with conventional fuel in their boilers (Reference 1); Reference 2 discusses the segregation of Air Force wastes for energy recovery.

The use of tracers has been suggested to reduce the cost of test burns and to provide a means of continuously monitoring on-line units. Compounds introduced into the incineration unit could serve as tracers for the purpose of verifying waste destruction removal efficiency. Sulfur hexafluoride offers several advantages as a tracer, including high thermal stability and ease of detection. The use of tracers and the advantages of SF_6 as a tracer are discussed in Section III.

C. SCOPE

This study sought to identify the relationships between several combustion parameters and the destruction removal efficiency (DRE) of SF₆ in a laboratory flame. Exhaust samples were analyzed using gas chromatography. Careful control of experimental parameters under laboratory conditions permitted the development of relationships that would be difficult to evaluate using data from a full-scale boiler or incinerator. These relationships could provide a starting point for analyzing similar data from larger-scale systems.

The ultimate goals of this research were to verify the potential of SF₆ as a tracer for DRE verification and to determine if full-scale testing in a boiler is warranted. Successful analysis of the SF₆ data would show trends leading to failure mode operation (DREs less than 99.99 percent) or, possibly, a means of DRE prediction. In addition, the potential use of SF₆ as an indicator of mixing was examined. Since mixing is an important parameter affecting waste DRE, a mixing indicator would be useful in optimizing waste destruction.

SECTION II

FACTORS AFFECTING DESTRUCTION REMOVAL EFFICIENCY

A. DESTRUCTION REMOVAL EFFICIENCY

Destruction removal efficiency (DRE) is the term used most often to describe hazardous waste destruction in a thermal processing facility. Thermal incineration uses high-temperature oxidation as the primary means to change the chemical or physical, character or composition of the waste (References 1 and 3). The wastes are generally one or more hazardous compounds diluted in a larger mass; thereby, greatly increasing the total quantity of material to be destroyed. The actual hazardous compounds, principal organic hazardous constituents (POHCs), have been defined by the EPA under the Resource Conservation and Recovery Act (RCRA).

Products of incomplete combustion (PICs) are another concern. In a properly designed and operated incinerator, PICs are emitted only in insignificant amounts and are not considered hazardous (Reference 3). Dioxins, also PICs, are dangerous even at low levels. Studies have been conducted on dioxin formation in incinerators, and information on its formation is available (References 3, 4, 5, 6, and 7).

Products of incomplete combustion can also be formed during the combustion process. Hexachlorobenzene is an example of a compound that has a high-temperature formation process. It can sometimes be measured as a PIC even when it is not present in the waste stream.

Destruction removal efficiency, or DRE, of the POHC is based on the combined effects of thermal destruction in the incinerator and removal from the exhaust by air pollution control devices (Reference 3). It is measured on a mass basis, as shown below

$$DRE = \frac{w(\text{in}) - w(\text{out})}{w(\text{in})}$$

where w = mass flow of POHC

The ash, scrubber water discharge, and other discharges are not included in the DRE measurements, but they are often hazardous materials themselves. Also, DRE does not apply to metals or other noncombustibles (Reference 8). A DRE of 99.99 percent for each POHC in the waste is required. Measurement of the small amount remaining can be difficult.

Four main factors affect DRE: residence time, temperature, excess air, and mixing. The time, temperature, and excess air

can all be measured and compared between incinerators. Mixing cannot be measured and is generally achieved through experience and overdesign. Each incinerator and waste have different mixing characteristics (Reference 3). For instance, liquid-phase wastes require a nozzle capable of atomizing the waste. This is not a problem for gas or solid wastes.

B. TIME AND TEMPERATURE CONSIDERATIONS

The fundamental rate of destruction of a given compound can typically be described by the first-order Arrhenius equation.

$$dm/dt = -km$$

$$k = Z \exp(-E/RT)$$

where m = mass of POHC
T = absolute temperature
t = time at temperature T
E = activation energy
k = kinetic rate constant
Z = preexponential factor
R = gas constant

Solving, and using the definition of DRE defined above gives

$$\ln(1-DRE) = -Z \exp(-E/RT) t$$

For a given DRE value, time versus temperature plots can be constructed for any given POHC. The curves shown in Figure 1 are oxidation curves for typical waste materials assuming a DRE of 99.99 percent. These curves can be used to estimate the residence time required at a given temperature, or the temperature required for a given residence time. Boiler operating profiles can also be superimposed on the graph to determine under what operating conditions the boiler can be used as an incinerator for a given waste or class of wastes (References 9 and 10). Conservative estimates may be obtained by using pyrolysis instead of oxidation curves.

Figure 1 shows that, at higher temperatures, shorter residence times are required. Conversely, low temperatures require longer residence times for a given compound.

C. MIXING

Temperature and residence time are both definable, measurable properties; however, the kinetic equation model described above assumes that the reactants are completely mixed (Reference 3). Mixing involves the combining of fuel, waste, and oxygen so that complete combustion occurs at the proper time and temperature.

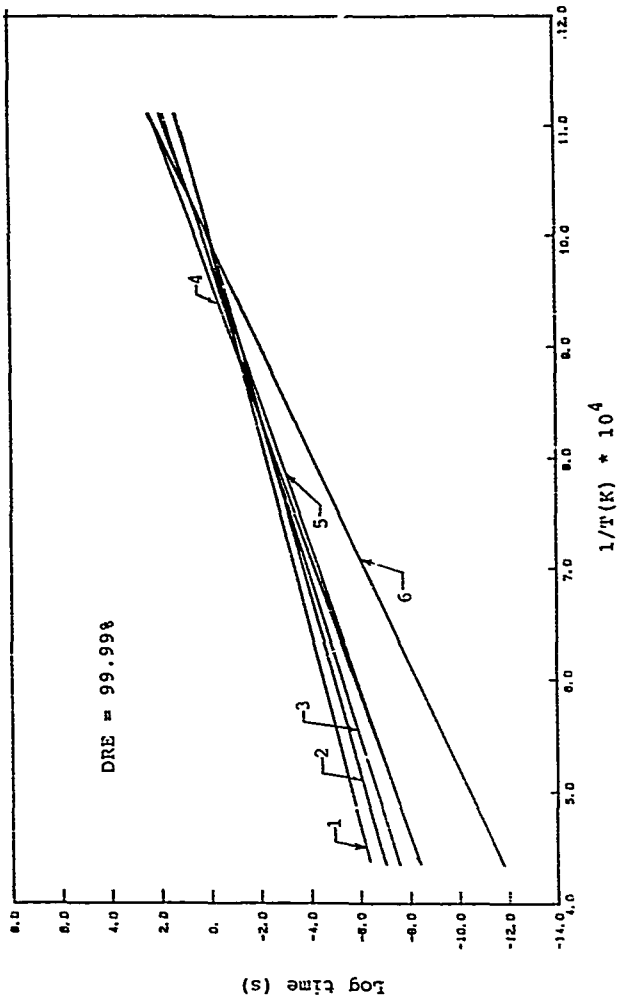

Figure 1. Incinerability Curves. Incinerability curves are shown for compounds occurring in selected hazardous waste streams. 1-acrylonitrile, 2-toluene, 3-vinyl chloride, 4-hexachlorobenzene, 5-pentachlorobiphenyl, 6-benzene. Curves are for oxidation.

Plotting residence time versus temperature profiles for typical incinerators or boilers will show that most have adequate time/temperature profiles to destroy nearly all wastes. In many cases, however, the reaction rate does not control the rate of incineration. Since the reaction rates are high at normal flame temperatures, it is the mixing characteristics that become rate-limiting. Unfortunately, the evaluation and control of mixing is difficult (References 3 and 9). The current state of the art allows determination of mixing only through past experience or by testing (Reference 8).

Since mixing can never be perfect, excess air is added to the combustion chamber to assure oxygen contact with the waste during combustion. The poorer the mixing, the more excess air is needed (Reference 11). Too much air is undesirable because of reduced incinerator/boiler temperature and increased heat loss through the exhaust.

An important factor affecting mixing is the degree of waste atomization achieved by the atomizing nozzle. The nozzle should be able to atomize the waste into a fine spray. In a properly designed spray nozzle, the individual droplets do not burn, but vaporize and burn as a diffusion flame (Reference 3, 11, and 12). Vaporization is affected by the atomizing ability of the nozzle. Factors affecting the degree of atomization are the viscosity, surface tension, and solids content of the liquid being atomized. The properties of the air or steam used to atomize the fuel/waste mixture, the relative velocities between the waste and atomizing air or steam, and the waste pressure also have an effect on atomization. Density of the waste has little effect and the effect of surface tension is small compared to viscosity (References 8, 11, and 13).

It is important to maintain proper atomization of the fuel/waste mixture. Large droplets with high momentum can cross the flame boundary and burn as individual droplets outside the flame zone or impinge on the furnace walls. This can be a major source of products of incomplete combustion. Many nozzles have this problem when burning wastes which were not designed to atomize (References 4 and 15).

Turbulence is also an important parameter affecting mixing. Increasing turbulence increases heat transfer, mass transfer, vaporization rates, and flame propagation rates. This leads to more efficient mixing of the waste with oxygen, and higher destruction (References 8 and 11). Swirl vanes are often employed to increase turbulence and promote mixing (References 3 and 11). The short, stubby flames produced in turbulent burners will reach flame temperatures faster and produce higher average incinerator temperatures than a long flame under the same conditions. Reference 3 describes this effect.

High-heat-release vortex burners are recommended for waste incineration on (Reference 3, 16, and 17). Vortex burners fulfill the high-turbulence requirement.

Finally, furnace geometry can also affect waste DRE. The furnace should be designed for long residence times. Burners should be placed in such a way that there is no flame impingement on the walls, or, if other burners are present, the flames should not touch one another. Flow through the furnace should promote mixing, even after the flame. The surface-to-volume ratio in the furnace should also be minimized. Decreasing this ratio reduces the effect of wall-quenching and its effect on DRC (Reference 18).

D. OTHER CONSIDERATIONS

Problems occur when burning wastes containing metals, sulfur, chlorine, or halogenated compounds. These can produce acids or particulate matter that require scrubbers or particulate removal systems. For some wastes, an alternative to incineration may be required (References 3, 8, 19, and 20). Alternatives include physical, chemical, and biological processes.

SECTION III

USE OF TRACERS

A tracer compound could be used to determine an incinerator's ability to destroy a given class of waste, thereby reducing the costs and difficulties associated with determining DRES of 99.99 percent for each of the POHCs in a waste stream.

Ordinarily, concentrations of each POHC in the waste must be known before incineration. Then, concentrations of the same POHCs must be determined after incineration to determine the DRES of each POHC. Since the incoming concentrations can be very small, it is difficult to measure the minute quantities of the POHCs remaining after incineration, especially when these are then further diluted by mixing with the fuel. Finally, this mixture is further diluted by atomization with the combustion air. During combustion, 99.99 percent or more of the POHC is destroyed. Additional dilution occurs during combustion. This leaves a final concentration so small that detection becomes difficult, if not impossible.

Use of a tracer, injected in place of, or combined with the POHC could reduce many of the problems associated with DRE verification. For instance, a tracer could be injected instead of the waste, and its DRE could be measured. The DRE of the tracer could then indicate the DRE that would be obtained for a given POHC, under the same conditions, with similar reaction characteristics.

A. DESIRABLE CHARACTERISTICS OF A TRACER

The residence time and temperature required to destroy a given POHC can be estimated using the first-order Arrhenius expression described earlier. After obtaining appropriate values for the rate constant and the preexponential term for a given POHC, it is possible to calculate the required temperature for a given residence time and DRE. Alternatively, one could calculate the residence time required at a given temperature to achieve a prescribed DRE. Examples of such residence times have been plotted for several typical waste materials (Figure 2). The plotted values are for oxidation and a DRE of 99.99 percent. Pyrolysis curves could be plotted in a similar manner.

If a tracer is used, it should be more difficult to destroy than any of the POHCs within the waste. There are several reasons for this. First, a DRE of 99.99 percent for a compound that is difficult to destroy would assure a DRE greater than 99.99 percent for a compound that is easier to destroy (based on first-order time and temperature considerations). Second, if the tracer is more difficult to destroy, there will be more of it to measure after incineration. Finally, a smaller amount of the tracer could be injected.

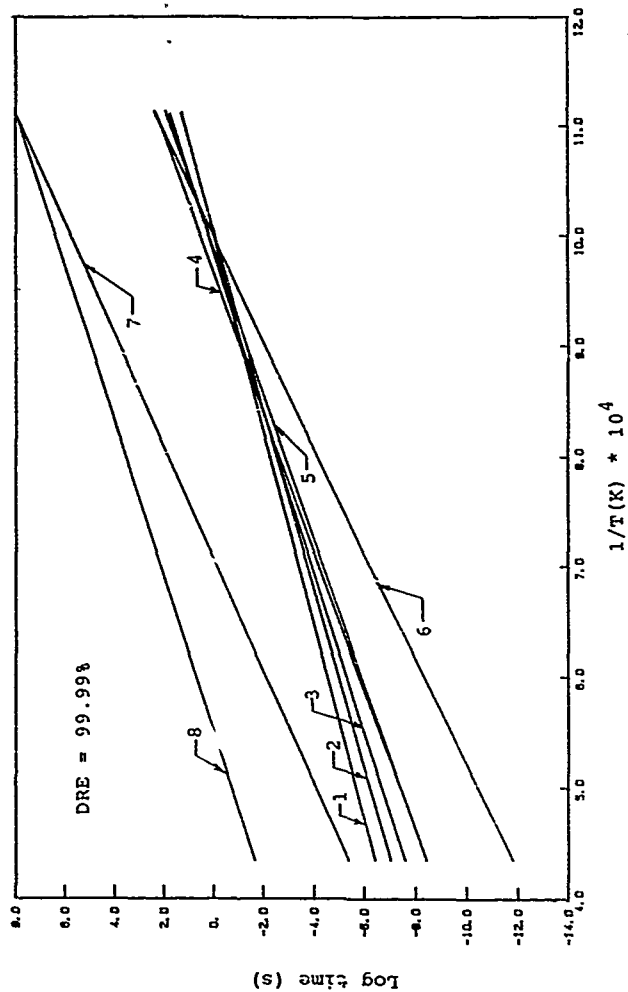

Figure 2. Incinerability Curves. Incinerability curves are shown for compounds occurring in selected hazardous waste streams. The tracers SF (7) and CF₄ (8) are shown for comparison. 1-acrylonitrile, 2-toluene, 3-vinyl chloride, 4-hexachlorobenzene, 5-pentachlorobiphenyl, 6-benzene. SF₆ and CF₄ are pyrolysis curves, but are not expected to differ significantly for oxidation.

SF₆ and CF₄ are included in Figure 2 and represent desirable tracers from a time-temperature point of view. The curves for SF₆ and CF₄ are pyrolysis curves. They are not expected to change significantly for oxidation and are, therefore, treated as oxidation curves (References 21, 24, 28, and 26).

A tracer used for determining DRE on a continuous basis should be absent from any hazardous waste. This would permit testing DRE while burning a wide variety of wastes. If the tracer were present in a waste, an erroneous DRE measurement would be made.

The greatest advantage of using a tracer is the opportunity to choose the most convenient one. It should be more thermally stable than the POHCs, and comparatively easy to detect. An advantage of easy detection is that smaller concentrations are required on injection.

Any tracer chosen should be nontoxic. Release of hazardous compounds during test burns would not be desirable, especially if testing is done on a continuous basis.

The tracer should be in the same phase as the waste. Gas-phase surrogates should be used for gas-phase wastes. Liquid or solid surrogates should be used for liquid or solid wastes. For instance, a gas-phase surrogate could not model the atomization characteristics of a given nozzle. If a liquid waste could not be properly atomized, it could be blown through the flame without appreciable destruction. A gas-phase tracer could not predict this. When a liquid tracer is used for a liquid waste, the relevant aspects of its behavior should be similar to the waste; i.e., variables affecting atomization and evaporation rates should be similar.

B. CANDIDATE TRACERS

Until recently, little data existed on the use of tracers for incinerator testing. Many tracers have been proposed. One possibility is the use of a waste material that is difficult to destroy, such as hexachlorobenzene. This liquid is also easy to measure with an electron capture detector (ECD) on a gas chromatograph (GC). Successful destruction of this compound would assure destruction of all less stable species (based on first-order time and temperature considerations). It has the disadvantage that it is a hazardous material and should not be used on a continuous basis. It also occurs in many hazardous waste streams and verification of DRE would be simplified if the tracers were not originally present in the waste. In that sense, hexachlorobenzene is actually a poor choice because it is a product of incomplete combustion (PIC) and can be formed in the combustion process (References 24, 25, and 26).

Hexachlorobenzene is not the only possibility of this type. Other researchers have used various mixtures of typical hazardous waste materials during verification burns and tests. These will not be discussed here.

Freon 113 has been tested as a tracer (References 4, 24, 27, 28, and 29). Being a liquid, Freon 113 was capable of modeling the atomization characteristics of the nozzle, as well as the time/temperature history within the furnace. Also, it was readily mixed with the waste material. These were significant advantages. Freon 113 is also low in toxicity and easy to detect (Reference 28).

Results showed that the Freon 113 could be used as a tracer for liquid wastes and that it was as difficult to destroy as the POHCs used in the tests. Reference 28 also studied sulfur hexafluoride as a tracer. Comparison with Freon 113 suggested that SF₆ could be used in much lower concentrations and determine DRE to an even higher degree, even on a continuous basis. The ease of measurement made SF₆ an attractive surrogate.

C. SULFUR HEXAFLUORIDE AS A TRACER

Reference 23 recommended perfluorinated compounds as candidate tracers, in particular, CF₄, C₂F₆, C₃F₈, C₄F₁₀, CF₃Cl, and SF₆. References 27 and 28 also recommended SF₆.

Sulfur hexafluoride, a gas, is a particularly good candidate tracer for several reasons. First, it is more stable than most wastes (Figure 2). If SF₆ can be destroyed to a 99.99 percent DRE in an incinerator or boiler, then a hazardous waste material, that is less thermally stable, should be destroyed to greater than 99.99 percent DRE (based on first-order time and temperature considerations). Second, SF₆ is not present in most hazardous waste streams. This eliminates the possibility of an erroneous DRE measurement caused by tracer compounds in the waste material. Third, it is easy to detect. Concentrations as low as four parts in 10¹⁴ have been detected using an electron capture detector in a gas chromatograph (Reference 30). An advantage arising from the use of an ECD is that it is insensitive to most hydrocarbons or other products of combustion normally present in the sample. Since SF₆ is so thermally stable, compared to most POHCs, and since it is relatively easy to detect, little is needed in the input waste line. Reference 23 suggested using as little as 1 ppm SF₆ in the fuel line. A final advantage of SF₆ is its nontoxicity.

Due to the high thermal stability and ease of detection, SF₆ would seem to be an ideal gas-phase tracer. Specifically, it appears to be the ideal tracer for testing boilers or incinerators for their ability to obtain a given DRE, or even for continuous monitoring of DRE (Reference 28). Tracer Technologies has designed an instrument capable of providing continuous measurements of SF₆ concentrations as low as 50 ppt. Such tests

could be performed more easily and at lower costs than measuring the POHCs directly. Since most incinerators and boilers have an adequate residence time for their temperature levels to destroy a given waste, the mixing characteristics often determine a POHCs DRE. SF_6 is well-suited to measuring both the time and temperature histories of the waste, as well as the mixing characteristics.

One disadvantage of SF_6 as tracer is that it is not in the same phase as most waste materials. Most wastes are in the liquid phase, whereas SF_6 is in the gas phase. A liquid-phase tracer would indicate the time, temperature, and turbulence, and the nozzle's atomization characteristics. Reference 28 recommends Freon 11 and Freon 113 for volatile POHCs and Freon 22B1 for solid wastes. If complete vaporization of the waste is assumed to occur before the flame front, then SF_6 becomes the tracer of choice. This assumption should be valid when using modern, high-efficiency vortex-type burners.

SF_6 has been used as a tracer compound for many years. It has been used in meteorological studies of the atmosphere (Reference 30 and 31), studies of pollutant dispersal from smoke stacks (References 32, 33, and 34), studies of air infiltration in mobile homes (Reference 35), and studies of the mixing characteristics of gases in diesel engines (Reference 36).

D. RATIO TECHNIQUE

As described earlier, exhaust flow must be known to determine DRE from the concentration measurements. An alternative is the use of a ratio of two tracers. One tracer is chosen that is completely stable in the incinerator environment, whereas the other (SF_6) reacts so that it will be partially destroyed (Reference 23). Such a procedure could eliminate the need for absolute concentration measurements. That is, when a known ratio is injected and a ratio is measured after incineration, exhaust flow measurements become unnecessary. This eliminates a large source of error.

E. OTHER INDICATORS OF DRE

Methane and total hydrocarbon emissions have also been investigated for use as indicators of DRE (References 15, 37, 38, 39, and 40). Since many incinerators use methane as the primary fuel, and since methane is more difficult to destroy than many of the hazardous wastes, it was determined that methane DRE could indicate the degree of destruction of the POHC. Among the studies cited above, References 39 and 40 found a nearly linear relationship between either total hydrocarbons or methane and DRE. Further work is needed in this area.

Carbon monoxide has also been studied as an indicator of poor DRE. Two investigators report that CO must increase to substantial concentrations before DRE begins to degrade

(References 15 and 39). Others report little or no correlation between DRE and CO (References 37 and 41).

Finally, Reference 18 has suggested NO_x formation as a predictor of incinerability in a given boiler. The author argues that any boiler capable of producing significant NO_x concentrations should also have the environment necessary to destroy the POHCs.

F. SELECTION OF A TRACER

Based on the information cited in this section, it was decided to conduct an indepth experimental evaluation of sulfur hexafluoride as a tracer. The study was conducted on a laboratory scale where careful control of the experimental parameters allowed the development of relationships that would be more difficult to derive with raw data obtained from a full-scale boiler or incinerator. These relationships could provide a starting point for analyzing similar data from bench-scale or actual incineration systems.

SECTION IV

EXPERIMENTAL APPROACH

The experiment was conducted in two phases. The first phase consisted of a detailed examination of the parameters affecting SF₆ DRE. Parameters of interest were fuel flow, air flow, carbon monoxide emissions, and temperature. The second phase was concerned with comparing the DRE of SF₆ with the DRE of the four surrogate wastes, and to observe the effects of altered mixing on SF₆ DRE. Because of the nature of experiment, the procedure for each part will be discussed separately.

The experimental apparatus for the first experimental phase consisted of four subsystems: the tracer-mixing system, burner, exhaust system, and exhaust-sampling system. The apparatus was adjusted in the second phase to include a waste-mixing system. The burner was also altered to change the mixing characteristics in the flame zone. SF₆ was burned in both parts of the experiment. The surrogate wastes were burned only in the second part.

The tracer-mixing system was responsible for mixing the tracer (SF₆) with the fuel and supplying fuel and air to the burner. Similarly, the waste-mixing system mixed a waste with the fuel and supplied fuel and air to the burner. The burner and exhaust systems were responsible for combustion of the fuel and removal of the exhaust gases. The exhaust-sampling system was responsible for withdrawing representative samples for analysis.

A. TRACER-MIXING SYSTEM

It was desirable that the tracer mixing system be kept simple; however, the requirement of a low tracer flow rate caused some difficulty. The layout of the gas flow system is shown in Figure 3. As shown, the fuel flow was controlled by a valve at the inlet to the mixer. Flow was measured by means of a Fisher & Porter rotameter (model FP-1/4-20-G-5/36), calibrated for the pressures and flow rates used. Fuel flow rates varied from 100 to 235 ml/s.

The compressed air flow was measured using a Fisher & Porter rotameter (model FP-3/4-21-G-10/83). Factory calibration curves (± 2 percent of full scale) were used. Flow was controlled in the range from 2300 mL/s to 3800 mL/s using two pressure regulators in series. No variation in flow rate was observed.

The SF₆, 99.7 percent pure, was supplied from a pressurized cylinder at approximately 300 psi. A pressure regulator reduced the pressure to 40 psi before entering the tracer-mixing system. A valve was installed near the end of the line to keep the SF₆ within the line pure when the flow was turned off. The SF₆ flow rate was controlled using a fine-metering valve (Nupro, S-series). Even with the fine-metering valve in place, flow

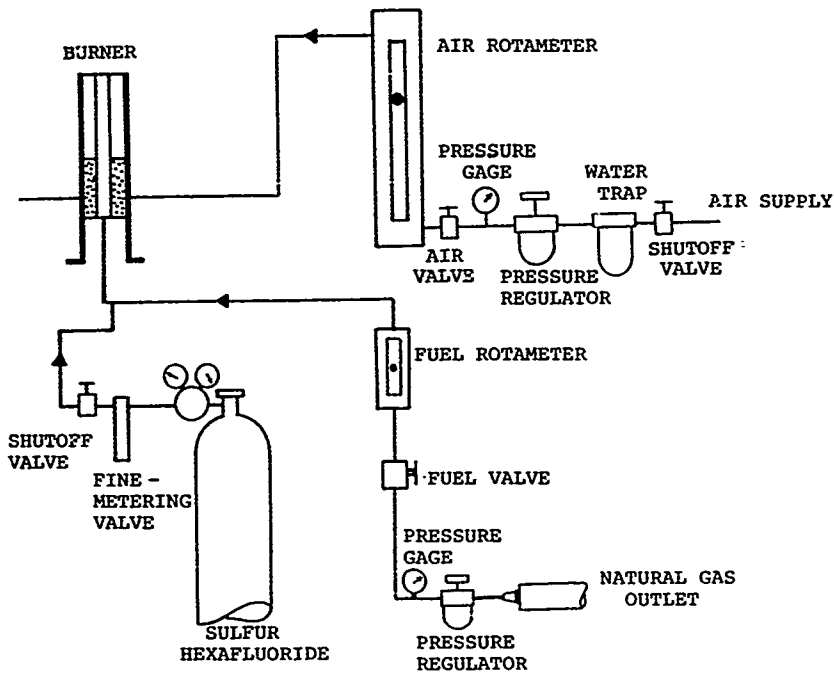

Figure 3. Gas-Handling System Used for SF_6 .

control at the low flows required was difficult. Adjusting the fine-metering valve to its nearly closed position allowed flow rate of about 1 mL/min. This created a final concentration, after mixing with both the air and fuel, of between 2 ppm and 4 ppm. This was considered sufficient. In principle, lower flows could have been obtained by reducing the pressure of the SF₆; however, when tested, this led to poor flow control.

The SF₆ was injected directly into the fuel line by use of a tee in the line. From the mixer, the fuel/tracer mixture went directly to the burner. This system was used for the SF₆ in both parts of the experiment.

B. WASTE MIXING SYSTEM

At the time of this experiment it was not possible to simultaneously analyze for both the SF₆ and the surrogate wastes. This problem is discussed in greater detail later in this section. The analysis constraints required that the SF₆ and the surrogate wastes be burned at different times. Figure 4 shows the system used with the surrogate wastes.

During the waste burns the SF₆ supply was disconnected from the fuel line. The waste was introduced into the fuel line by bubbling the gas through approximately 1 liter of liquid waste in an Erlenmeyer flask. The waste could not enter the burner as a liquid because of the possibility of droplets passing through the flame zone unburned. The flask was kept immersed in a bucket of water to maintain the liquid waste at a constant temperature throughout the experiment.

The flask was installed in the fuel line, downstream of the rotameter, which was recalibrated for the new flow configuration of the waste burns. The fuel line then passed through a hole in the stopper in the top of the flask and into the liquid waste.

Based on saturation pressure, the waste evaporated into the fuel line as the gas was bubbled through it. The four surrogate wastes under consideration had different evaporation rates; therefore, it was possible to use only one waste compound at a time.

C. BURNER DESIGN

The burner was originally designed as a bluff-body burner for use with high air flow to stabilize the flame. It had an all-metal design (Figure 5). Because of the low air flows used in this experiment, the flame was not stable at the higher fuel flows required. The small nozzle within the burner produced such high jet velocities that the flame would "blow off" at all but the lowest fuel flows. Rather than design a new burner, a simple flame holder was developed to hold the flame at all flow levels. It consisted of a 1.27 cm diameter steel ball bearing placed 1 cm above the nozzle (Figure 5). This produced a recirculation zone

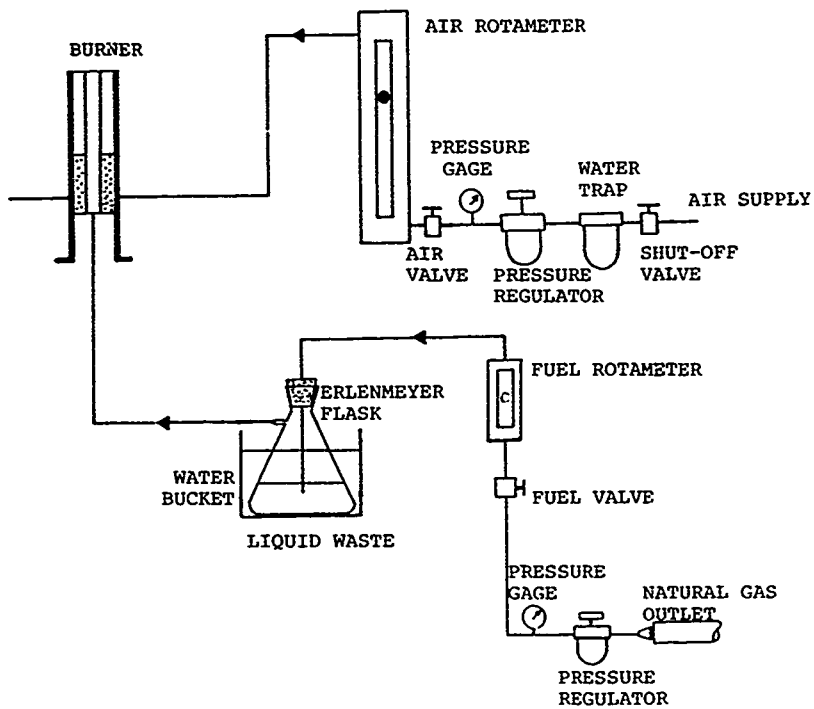

Figure 4. Gas-Handling System Used for the Surrogate Wastes.

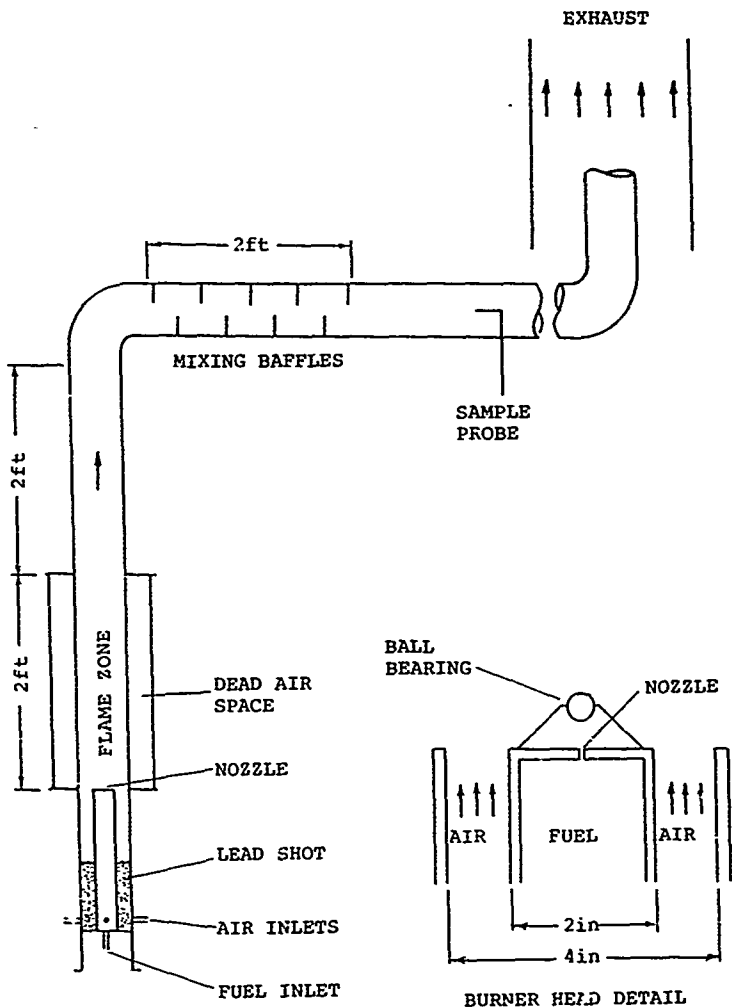

Figure 5. Burner and Exhaust System. Note the burner head detail showing the location of the flame stabilizing ball bearing.

behind the ball that slowed the flow enough to permit combustion. The resulting flame was stable and resembled a natural gas boiler flame, but on a smaller scale (Figure 6).

For the second phase of the experiment, a 2.54 cm ball-bearing was used to change the mixing characteristics in the flame zone.

The combustion zone was enclosed by a 4-inch diameter steel duct, directly connected to the exhaust system. Around the 4-inch duct was a 6-inch duct, sealed at the top to prevent air circulation with the outside air (Figure 5). This outer duct, and the open air space between, were used as insulation for the combustion chamber, allowing the wall temperature of the inner duct to reach levels closer to those experienced in a refractory-lined incinerator or boiler.

D. EXHAUST SYSTEM

The burner exhaust continued through the 4-inch diameter duct to an exhaust vent leading outside the lab building. The exhaust was vented using a forced-draft fan for the first phase. For the second phase, the exhaust was simply vented to the atmosphere. To permit temperature and pressure measurement during the tests 1/16-inch holes were positioned at 8-inch intervals through the exhaust piping. In addition, a set of 1- by 2-inch baffles were installed in one 2-foot section of the duct to facilitate mixing of the exhaust gases before sampling (Figures 5 and 7). A temporary exhaust system, made from a 10 cm diameter section of Pyrex[®] tubing, was used to observe the flame during operation (Figure 6).

E. EXHAUST-SAMPLING SYSTEM

As mentioned above, the exhaust system had numerous small holes for temperature probe insertion or pressure measurement. Temperature measurements were made using a Type K (chromel-alumel) grounded thermocouple housed in a 1/16-inch diameter stainless steel probe. Temperature measurements up to 1170 K were possible. A shielded thermocouple was installed permanently in one location and surface temperature measurements were made using a surface probe. Figure 7 shows the location of the permanently mounted thermocouple and temperature measurement locations. Temperatures were recorded only in the first part of the experiment.

Gas samples were extracted through a 1/4-inch diameter section of copper tubing near the end of the exhaust system (Figure 8). Here the temperatures were low, typically 525-630 K. The gases were then routed through a copper coil, submerged in water, to cool them to near ambient conditions. After cooling, the gases were routed through a gas-sampling bottle. The purpose of the bottle was to collect water that condensed during the cooling process. A self-sealing septum on the side of the bottle

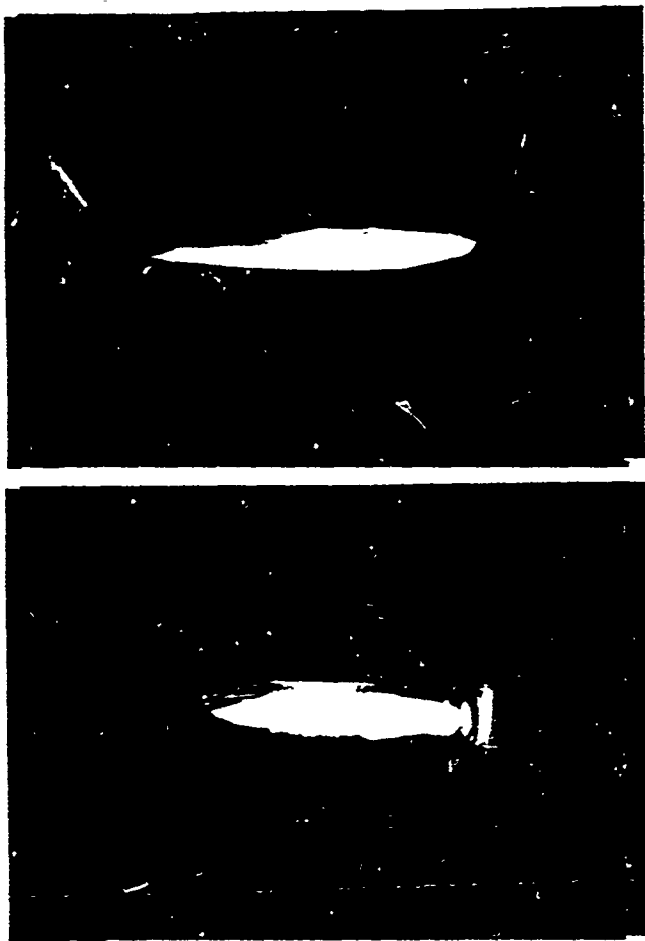

Figure 6. Photograph of flame. The photo on the left shows the flame under minimum fuel flow conditions. Maximum fuel flow is shown on the right. A 10 cm diameter glass tube surrounded the flame to approximate the fluid mechanics of the actual system.

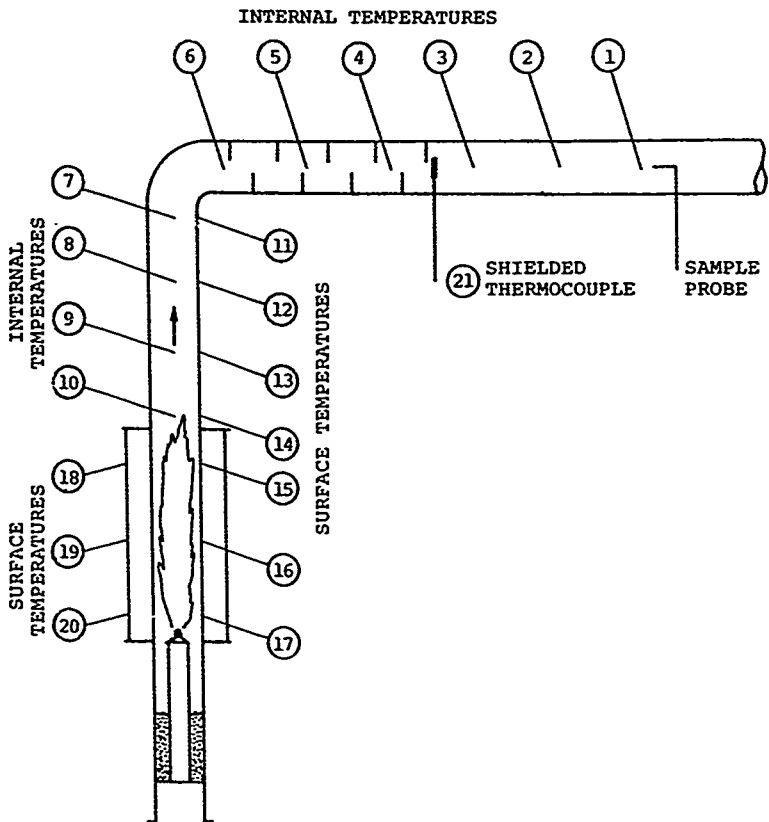

Figure 7. Temperature Measurement Locations. Internal duct temperatures were recorded at 10 locations and surface temperatures were recorded for an additional 10 locations. A shielded thermocouple was used for daily comparisons of data.

permitted samples to be taken using a syringe. A vacuum pump was attached to the outlet side of the sampling bottle to extract samples from the exhaust pipe.

The same sample withdrawal system could not be used for the surrogate wastes. Some of the waste compounds would be absorbed into the condensate during cooling; therefore, the sample to be analyzed for waste compounds was removed with a syringe directly from the stack (Figure 8). This method of sampling was not expected to noticeably affect the sample measurements.

Sample analysis was done using a Perkin Elmer, model Sigma 300 gas chromatograph (GC). An electron capture detector (ECD) was used for SF₆ analysis; a flame-ionization detector (FID) was used for the surrogate waste analysis. The ECD is sensitive to water, requiring the use of the water removal system; however, the FID is not sensitive to water, and the samples could be withdrawn directly from the stack. The GC was not able to analyze samples using both detectors either simultaneously or alternately. This limitation required that the SF₆ and the surrogate wastes be burned at different times. However, careful control of the experimental parameters allowed comparison of the exhaust samples collected at different times. The GC has since been modified to allow alternate use of both detectors.

A stainless steel, 24-foot by 1/8-inch diameter, 45/50 mesh molecular sieve (5A) column was used to separate the SF₆ from oxygen. (This gave long retention times indicating a need for a shorter column.) A 30-meter by 0.75-millimeter diameter wide-bore capillary column was used to separate the waste compounds. The data were integrated automatically using a Perkin Elmer, LCI 100 laboratory integrator. The syringe used was a 1 mL gas-tight syringe with a locking valve for sample storage.

A Teledyne, model 990, portable flue gas analyzer was also connected to the gas sample line (Figure 9). The analyzer is digital and is capable of measuring 0.0 to 25.0 percent oxygen and 0 to 1000 ppm carbon monoxide. The analyzer had a built-in pump for sample withdrawal. The oxygen analyzer was shown to be accurate by comparison with measurements made on the GC; however, the CO analyzer was not as reliable and a large random uncertainty existed with these measurements, typically 5 to 10 ppm.

All data were entered into an Integrated Solutions, UNIX-based computer to be analyzed.

F. PHASE 1: SULFUR HEXAFLUORIDE EXPERIMENTAL PROCEDURE

The wet- and dry-bulb temperatures of the compressed air supply were measured. In addition, a sample of the air was injected into the gas chromatograph (GC) to detect any SF₆ present in the air supply.

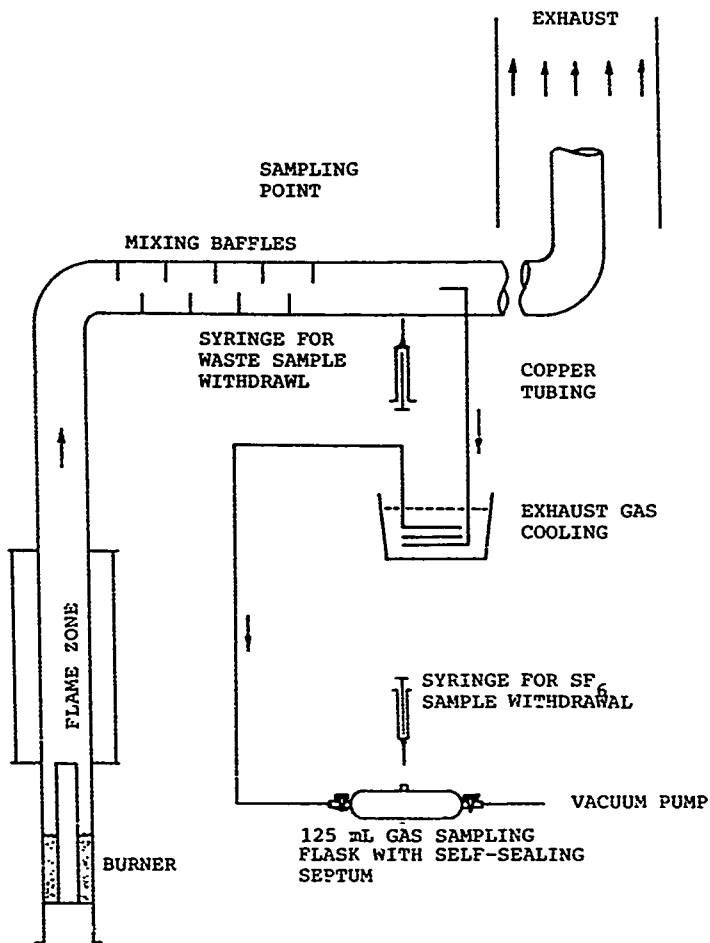

Figure 8. Gas-Sampling System.

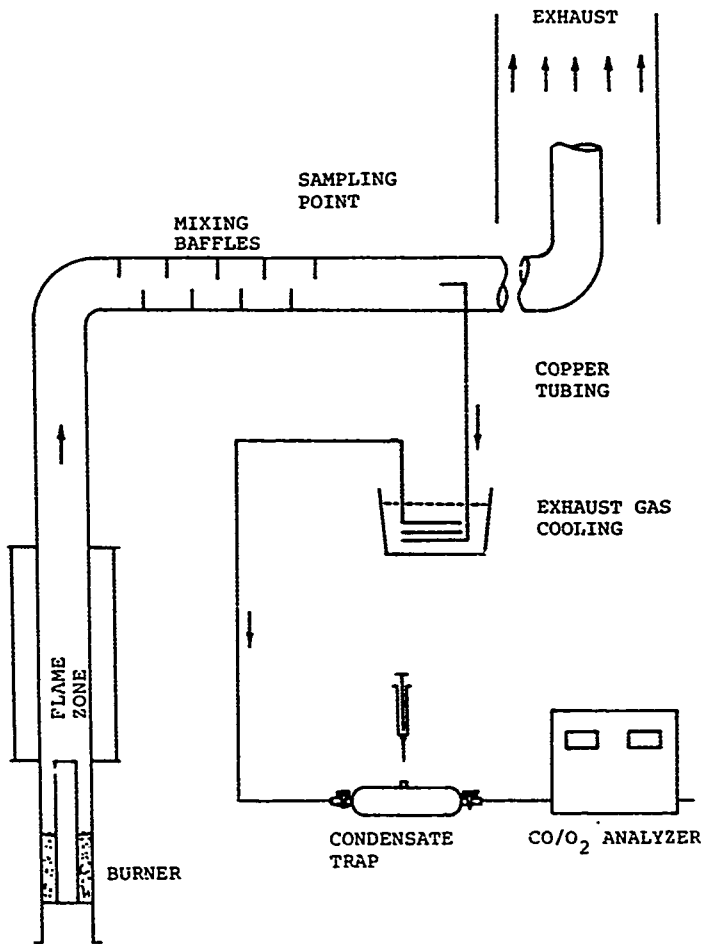

Figure 9. CO/CO₂ Sampling System. The CO/CO₂ sampling system was similar system to the SF sampling system. A CO/CO₂ analyzer with a built-in pump was used for the measurements.

Problems were encountered with the gas-tight syringes. It was found that the SF₆ was strongly absorbed in the Teflon® plunger and valve parts. For this reason, a pure outdoor air sample, containing no SF₆, was taken and injected into the GC. If an SF₆ peak was detected, a new syringe was used. These problems only occurred during sample preparation involving high concentrations of SF₆.

Finally, the CO/O₂ analyzer was calibrated. Ambient air was used to calibrate the oxygen analyzer to 20.9 percent O₂ and a 940 ppm CO-in-nitrogen calibration standard was used for the carbon monoxide.

The GC was operated at ambient temperature (oven/injector temperature approximately 30° C) using nitrogen as the carrier gas. Column flow was accurately maintained at 30 mL/min with an additional 30 mL/min makeup gas for the ECD. All analyses were done using a detector temperature of 300° C and a current range setting of 2. This detector current proved to be unsatisfactory for some of the low concentrations obtained. A maximum detector current and a shorter column are recommended for future work. The septa were replaced regularly and were of the non-Teflon® variety. Teflon® was avoided because of problems with SF₆ absorption.

Peak area and height were automatically measured, using a Perkin Elmer, LCI 100 laboratory computing integrator. Since the peaks to be measured were small, the area sensitivity was changed from its default value of 10 to a reduced value of 2. Otherwise, the peaks obtained were well-resolved and generally required no special treatment in integration.

An external calibration standard consisting of 1.02 ppm SF₆ in nitrogen was used to calibrate the ECD. Injecting 1-milliliter-size or smaller samples into a 1000 mL gas-sampling bottle with a self-sealing septum enabled accurate concentrations to be prepared ranging from 1.02 ppm down to less than 0.1 ppb. This covered the full range of concentrations to be measured and provided an accurate calibration curve (Figure 10). This was especially important since the data were outside the linear range of the detector. Samples made from the pure SF₆ were attempted, but many problems were encountered. Use of the calibration standard eliminated these problems.

The SF₆ flow was measured using a 10 mL soap-film flowmeter. A 5 mL volume was timed for accurate flow measurement. SF₆ flow rates were maintained at 1.2 mL/min and not varied through the test. At the end of the run the flow was measured again and averaged with the initial value. The error introduced by using this average was less than 0.08 mL/min. This averaged value was used in all calculations. After setting the SF₆ flow, the air flow was adjusted to the desired value, using the Fisher & Porter rotameter.

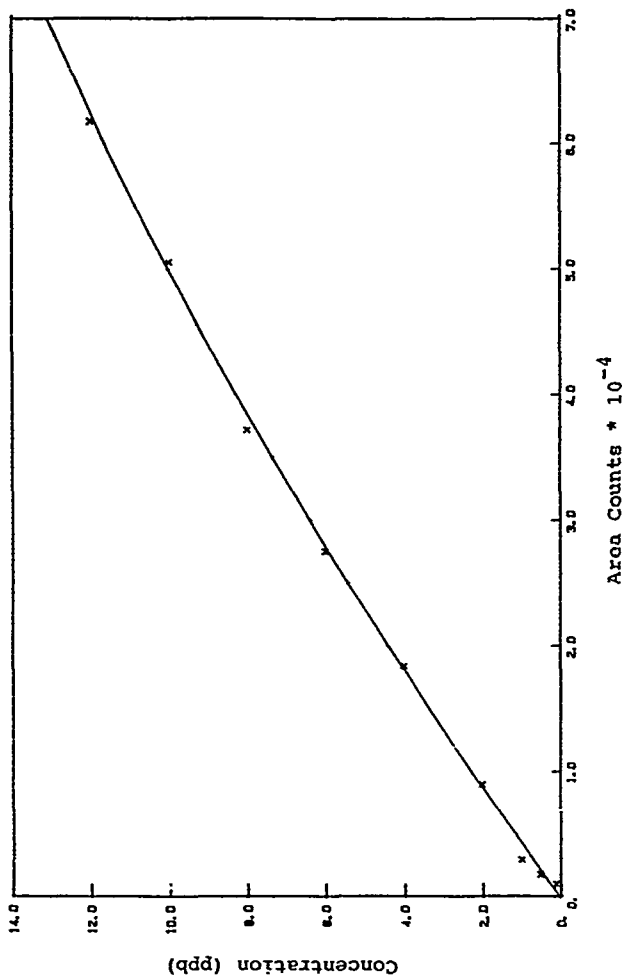

Figure 10. Gas Chromatograph Calibration Curve for SF₆ in Phase 1. The data were fit using a second-order polynomial. $PPB = 2.3407E-4 * AREA - 6.6707E-10 * AREA ** 2$.

Once the SF₆ and air flows were set, the fuel flow was set to the desired value and the flame was ignited. Approximately 15 minutes were required before the burner and exhaust system reached steady state. During the entire experiment the vacuum pump was left running to continuously draw fresh samples and maintain a representative gas sample in the sampling bottle.

Once a steady-state condition existed, a 0.4 mL sample of the exhaust was withdrawn from the sample bottle using the gas-tight syringe. This sample was then injected into the GC for oxygen and SF₆ peak area measurements.

Oxygen and carbon monoxide content of the exhaust was measured using the Teledyne CO/O₂ analyzer. The instrument used was a digital model and required a certain amount of "visual" averaging of the readout. Similar problems were encountered with the digital thermocouple.

After injecting the sample in the GC and recording the CO/O₂ measurements, the fuel flow was varied and the procedure repeated for all desired fuel flows. The air flow was varied only after the full range of fuel flows had been exhausted.

Temperature measurements were taken at 11 locations within the burner/exhaust system and another 10 measurements at other locations (Figure 7). The Type K (chromel-alumel) thermocouple, described in Section IV, was inserted into the duct for internal measurements, and a surface probe was used for surface measurements. Temperature measurement was slow and required time for equilibration from measurement to measurement. This time delay for each of the 21 locations affected all other measurements. Since increased time between samples meant fewer samples per day, this affected the GC measurements. Because it was desirable to have as many area measurements as possible on a given calibration curve, and since the curve varied slightly from day to day, it was decided to do the temperature measurements at a later time. The temperature measurements were not expected to vary significantly for a given set of conditions; however, to verify consistency of the temperature profiles from day to day, measurements were repeated at one location using the permanently mounted thermocouple.

G. PHASE 2: SULFUR HEXAFLUORIDE AND SURROGATE WASTES PROCEDURE

At the start of the experiment, the ambient temperature and barometric pressure were recorded. For the waste burns, the temperature of the water in the bucket was also recorded.

The injector and oven temperatures of the GC were set at 40 °C. Ambient values were not used as in Phase 1. Using set values for injector and oven temperatures gave more reproducible retention times, while not affecting detection accuracy. The detector temperature of the ECD was set at 300 °C. Nitrogen was used as the carrier gas. Column flow was maintained at 30 mL/min

with an additional 30 mL/min makeup gas for the ECD. A detector current range setting of two was used. Non-Teflon® septa were again used to avoid problems with SF₆ absorption.

The GC settings were modified for the surrogate waste analysis. The injector temperature used was 150°C; the oven temperature was 60°C; and the detector temperature of the FID was 250°C. Nitrogen was used as the carrier gas. Column flow was maintained at 6 mL/min. The detector current range was set at 1 to give the greatest sensitivity. The integrator attenuation was set at 1024 for analysis of the nonflame samples and for the calibration samples. For the analysis of the postflame gases the integrator was adjusted to its greatest possible sensitivity. This permitted detection of concentrations as low as 5 ppb.

The ECD was calibrated for SF₆ using the method of the first experiment. The resulting calibration curve is shown in Figure 11.

Development of an accurate calibration curve for the liquid wastes proved to be much more difficult. Calibration standards were not available in the laboratory at the time of the experiment. However, the FID is linear for a range of over 10⁷; therefore, it was necessary only to verify the FID linearity for the range of interest. Concentrations could then be linearly related to the LCI 100 area values.

Liquid waste samples were injected into the 1000 ml bottle through the self-sealing septum. A microliter syringe was used for the liquid injection. Once the liquid had evaporated, a sample was withdrawn and injected into the GC/FID. This method allowed the development of a relative calibration curve for concentrations ranging from 0.5 to 10 parts per thousand. The curve for trichloroethylene is shown in Figure 12. This curve could not be used as an absolute calibration curve because of the large uncertainty involved in accurately measuring the liquid sample. It did, however, demonstrate that the concentrations of interest were within the linear range of the detector.

The portion of the second part of the experiment concerned with SF₆ was conducted in the same manner as was done in the first part. The SF₆ flow was measured using a soap-film flowmeter. SF₆ flow rates were maintained at 1.75 mL/min and not varied throughout the test. As in the first part, the SF₆ was introduced into the fuel line.

The parameters varied during the experiment were fuel flow and air flow. Air flow rates were varied from 2300 to 3800 mL/s. Fuel flow rates were varied from 110 to 250 mL/s. Five air flows and five fuel flows were used to give a total of 25 data values for each compound burned. The burner was allowed to reach steady state before sample analysis was begun.

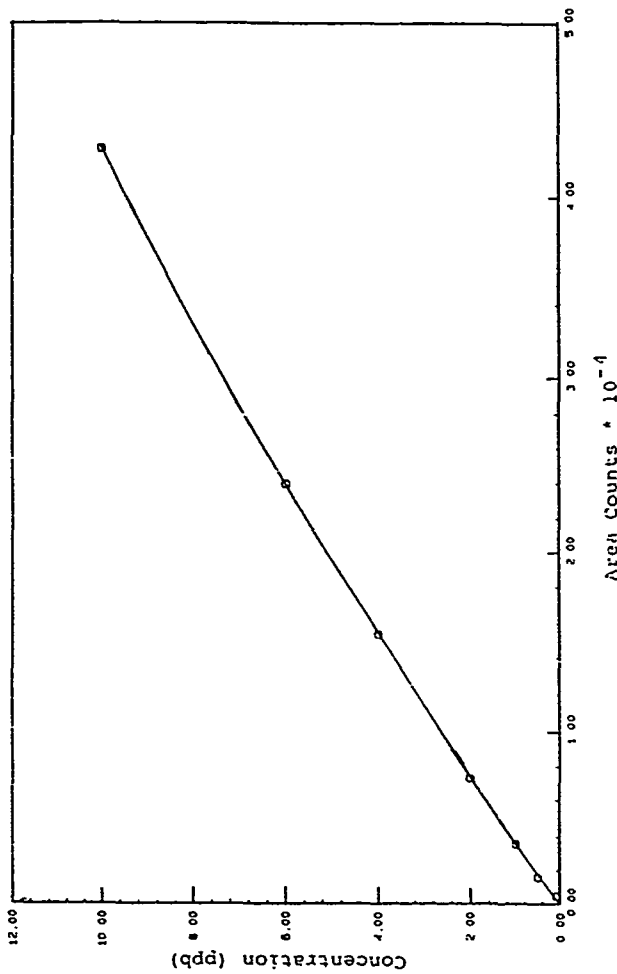

Figure 11. Gas Chromatograph Calibration Curve for SF₆ in Phase 2.
 The data were fit using a second-order polynomial. PPB =
 $2.1801E-2 + 2.7263E-4 \cdot \text{AREA} - 9.1195E-11 \cdot \text{AREA}^2$.

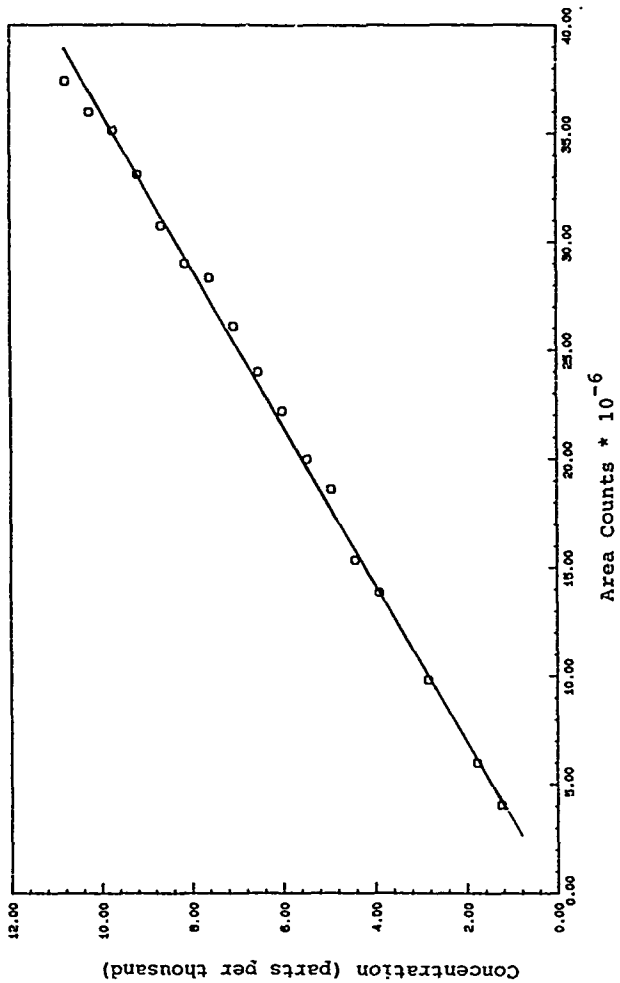

Figure 12. Gas Chromatograph Calibration Curve for Trichloroethylene. Curve was used only to verify that the FID was linear throughout the range of interest.

For the waste burns, the SF₆ line was disconnected and the fuel was bubbled through the liquid waste. Considerable difficulty was encountered in introducing the proper amount of waste into the fuel line. Too much waste in the fuel adversely affected the flame; too little waste in the fuel did not permit detectable amounts of the waste to survive the flame. Some control over the amount of waste evaporated into the fuel stream was achieved by adjusting the amount of waste in the flask.

Once a steady-state condition existed, the gas-tight syringe was used to withdraw a sample of the exhaust at the point where the SF₆ probe was inserted. A 0.4 mL sample was injected into the GC/FID for analysis. After samples were analyzed for all flame conditions, the process was repeated without a flame. This process was repeated for each of the four surrogate wastes.

Nonflame concentrations of the surrogate waste in the burner were required because there was no accurate way of measuring the amount of waste put into the burner. The nonflame data provided a means of determining the flow rate of the waste into the burner. The SF₆ flow into the burner was accurately measured, so nonflame concentration measurements of SF₆ were not required.

SECTION V
ANALYSIS AND RESULTS

This section is divided into four parts, corresponding to the two experimental phases. The first two parts cover the analysis and review the results of the first phase SF₆ data. The second two parts cover the analysis and describe the results from the second phase SF₆ data. The results of the second-phase SF₆ data are compared with the results from the first-phase data to observe the effects of altered mixing on SF₆ DRE. Also, the last two parts of this section review the analysis and describe the results for the surrogate wastes.

Nearly all of the results have been presented graphically. Because of the large amount of data obtained, and the large number of interrelated parameters, it was impossible to show how all points were related on a single graph. Instead, many graphs, each showing a particular trend (or lack of trend) were prepared. Where practical, a third parameter was included to increase their usefulness.

The final results were more important; therefore, extra care was taken to present these data in the most useful manner. Error bars, rather than a third parameter, were considered more important on these plots. The complete set of data is available through the University of Florida Combustion Laboratory.

A. PHASE 1 DATA ANALYSIS

1. Initial Analysis

The experimental data were entered into the computer. A program was then developed to analyze the collected data (Appendix A). Subroutine Stoich (Appendix B) was used for many of the calculations. It assumed a fuel (natural gas) consisting of 97.6 percent CH₄ (methane) and 2.4 percent C₂H₆ (ethane). Other components of the fuel were present in small quantities and were not expected to affect the results. Air and fuel flows were obtained from the rotameter calibration curves discussed earlier.

The analysis begins with the assumption of a chemical equation of the form

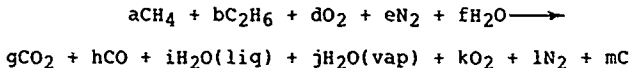

where a and b were obtained from the fuel composition and flow rate. The variables, d, e, and f, were obtained from the air flow rate and composition. The amount of water vapor was determined using the wet- and dry-bulb temperatures of the air in the air line.

Using a species balance, the saturation pressure of the water vapor at the temperature of the sample bottle, and the carbon monoxide concentration from the CO/O₂ analyzer provided the equations needed to solve for the remaining unknowns. The sets of equations were prepared. One set was used for equivalence ratios less than one. This set included moles of oxygen in the products and is listed below. The other set accounted for equivalence ratios greater than one and included moles of carbon (soot) in the products. A sample listing of these values is included in Appendix E.

CO concentration:

$$\text{ppm CO} = \frac{h}{g + h + i + j + k + l} \cdot 10^6$$

Saturation pressure (P) of water vapor:

$$P_{\text{sat, H}_2\text{O}}(T) = \frac{j}{g + h + i + j + k + l} P(\text{total})$$

Species balance (carbon, oxygen, hydrogen):

$$\begin{aligned} a + 2b &= g + h \\ 2d + f &= 2g + h + i + j + 2k \\ 4a + 6b + 2f &= 2i + 2j \end{aligned}$$

Subroutine Stoich also determined the air-fuel ratio, equivalence ratio, and the DRE of the SF₆. DREs were calculated using the area measurements from the GC. Four of the 121 sets of data had no SF₆ peak, so a detection limit peak area of 18 was ECD at its maximum current range and using a shorter column should increase the detection limits.

Uncertainties of the values obtained were calculated numerically in the main program (Appendix A) using the equation

$$w_y^2 = \sum \left(\frac{\partial y}{\partial x_i} \cdot x_i \right)^2$$

where w = uncertainty of value.
 y = calculated value
 x = measured value

Derivatives were done numerically using a central difference technique.

2. Problems With Air Leaks

One problem was discovered shortly after initial analysis of the data with Subroutine Stoich. When the actual percent of oxygen measured by the CO/O₂ analyzer was compared with that calculated by the subroutine, an obvious discrepancy was revealed (Figure 13).

An air leak into the system was the cause. The vent used to draw the exhaust gases to the outside created a slightly lower than ambient pressure within the burner and exhaust system. This reduced pressure (less than 1mm H₂O below atmospheric) created an influx of ambient air through the connections between the stovepipes and through the small temperature measurement holes. An attempt was made to correct this problem using special heat-resistant tape but the high temperatures allowed only partial success. For future work, a damper should be installed at the exhaust exit. This could be employed to keep the pressure inside the exhaust slightly above ambient, thus, eliminating the cause of the air influx.

The next alternative was to measure the leak rate. 99.99 percent pure nitrogen was blown through the air line of the burner/stovepipe assembly. With the exhaust ventilation fan turned off, the CO/O₂ analyzer showed minimal (<0.5 percent) oxygen within the system. The exhaust fan was then turned on and the oxygen analyzer showed 5.6 percent to 8.8 percent oxygen, depending on the nitrogen flow rate. This corresponded to leak rates of 1374 to 1386 mL/s, respectively. Assuming the total air influx was proportional to the volume flow rate of gases within the system, allowed the leak rate to be estimated from the measured total volume flow rate.

The air influx was unimportant when considering conditions at or near the combustion zone since most of the air influx occurred after the flame. It was important, however, when calculating the concentration of the SF₆. This air influx was, therefore, accounted for in the DRE calculations. Similar problems occur in boilers (Reference 25).

3. Calculation of Adiabatic Flame Temperature

The adiabatic flame temperature was calculated using the energy equation

$$\sum_{\text{react}} N_i (\Delta h_{f,298}^{\circ} + h_T - h_{298})_i = \sum_{\text{prod}} N_i (\Delta h_{f,298}^{\circ} + h_T - h_{298})_i$$

where

- N_i = moles
- $h_{f,298}^{\circ}$ = enthalpy of formation (298 K, 1 atm)
- h_T = enthalpy at temperature T, K
- h_{298} = enthalpy at 298 K

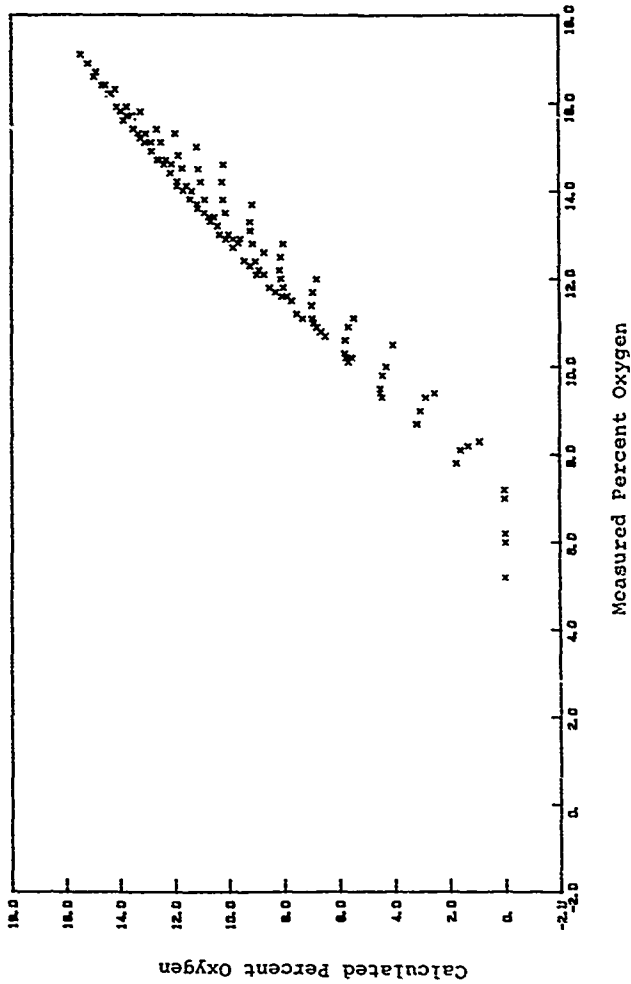

Figure 13. Calculated vs. Measured Oxygen. This figure shows the error introduced by the air leak into the system.

Enthalpy, heats of formation, and other values were taken from Reference 42. Data for C_2H_6 were taken from Reference 43. The adiabatic flame temperature was calculated in Subroutine Tadiabatic (Appendix C).

B. PHASE 1 RESULTS

Plots of the data obtained from the initial analysis show trends not easily accounted for without further analysis.

1. Effects of Flow Rate

Figure 14 shows DRE as a function of air flow. Data points within ± 50 K of a given adiabatic flame temperature have been connected with a least-squares fourth-order polynomial. Figure 15 is a similar plot, showing DRE as a function of fuel flow. Figure 16 shows DRE plotted as a function of total flow (air plus fuel) with lines of constant adiabatic flame temperature. These graphs show that high DRE can be obtained with either high or low fuel flow, high or low air flow, or high or low total flow.

2. Carbon Monoxide Emissions and Equivalence Ratio

Figure 17 shows no correlation between CO and DRE. However, the CO meter was not designed for the low concentrations measured, therefore, these measurements should be interpreted only in a general sense. Figure 18 shows no apparent correlation between equivalence ratio and the DRE of the SF_6 (not without considering other effects).

3. Temperature Effects

Figure 19 shows DRE plotted as a function of the temperature just above the flame, $T(10)$ (refer to Figure 7 for temperature measurement locations). Contrary to the expected results, if only kinetics were considered, higher temperatures seem to indicate lower DREs. Similarly, Figure 20 shows DRE as a function of the wall temperature of the combustion chamber, $T(15)$. One would expect lower DREs with lower wall temperatures (lower wall temperatures indicate cooler flame conditions). This figure does not show this effect.

Figure 21 shows DRE plotted as a function of the adiabatic flame temperature of the fuel/air mixture. Again, one would expect higher DREs at higher temperatures, a trend not shown here.

Finally, an analysis of the DRE caused by the downstream (beyond the flame) conditions was done using the measured temperature profiles. Figures 22 to 25 show typical temperature profiles. Using first-order kinetics and a flame temperature equal to the adiabatic flame temperature allowed the estimation of the DRE caused by the flame itself. Using the

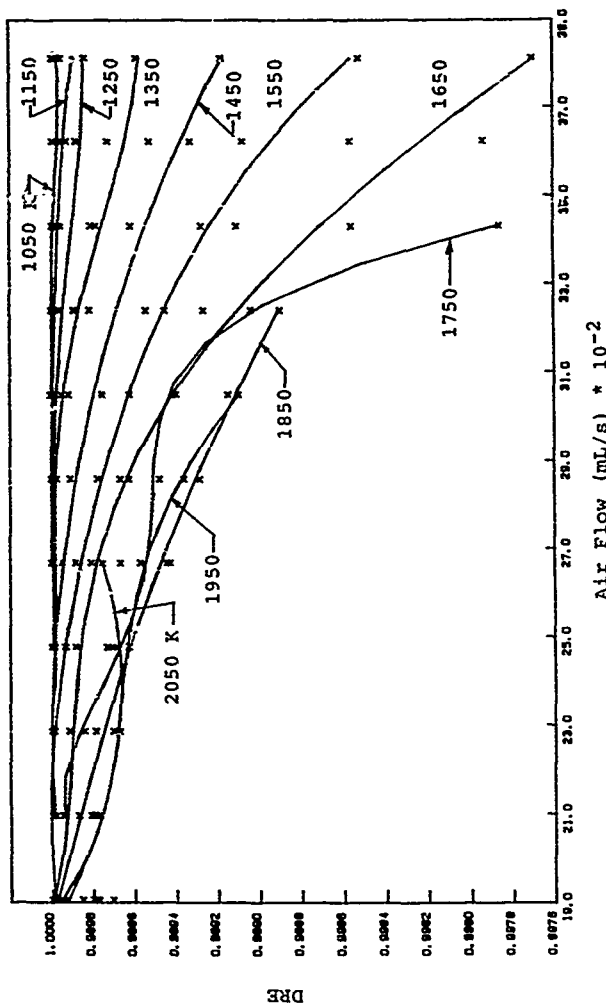

Figure 14. DRE vs. Air Flow. Lines of constant adiabatic flame temperature have been curve-fit using a fourth-order polynomial. The lines were fit to points ± 50 K of the given temperature.

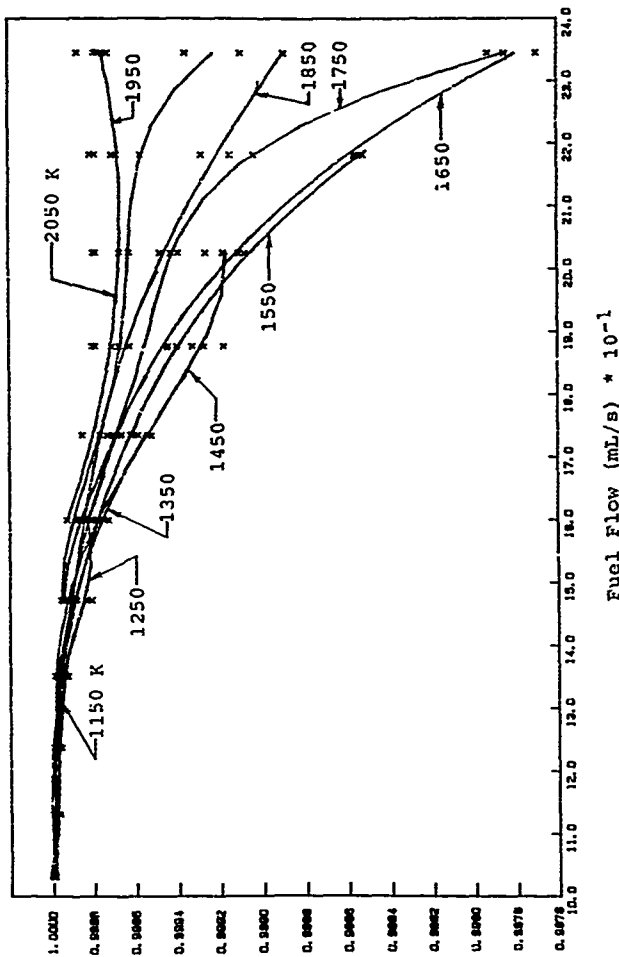

Figure 15. DRE vs. Fuel Flow. Lines of constant adiabatic flame temperature have been curve fit using a fourth order polynomial. The lines were fit to points ± 50 K of the given temperature.

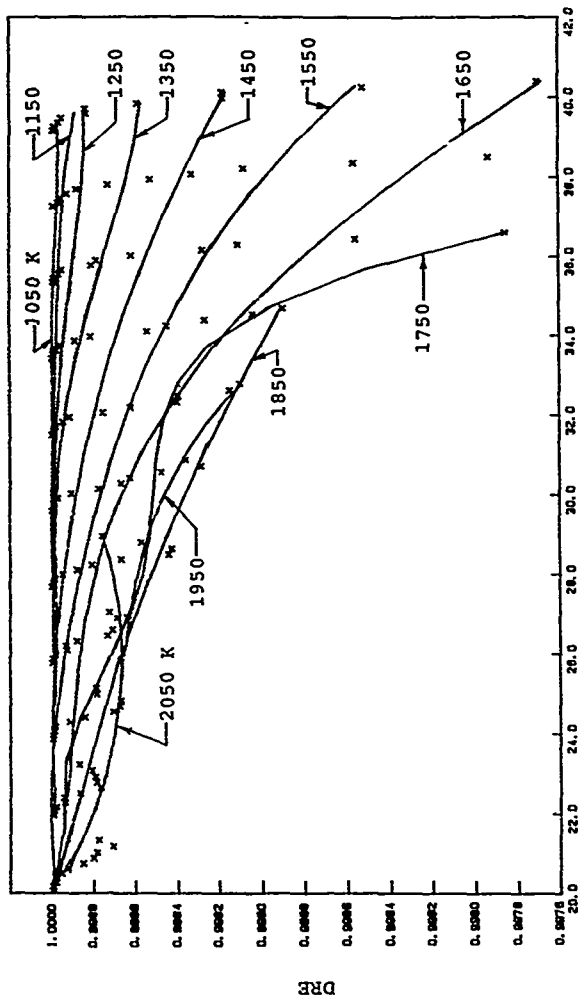

Figure 16. DRE vs. Total Flow. Lines of constant adiabatic flame temperature have been curve fit using a fourth order polynomial. The lines were fit to points ± 50 K of the given temperature.

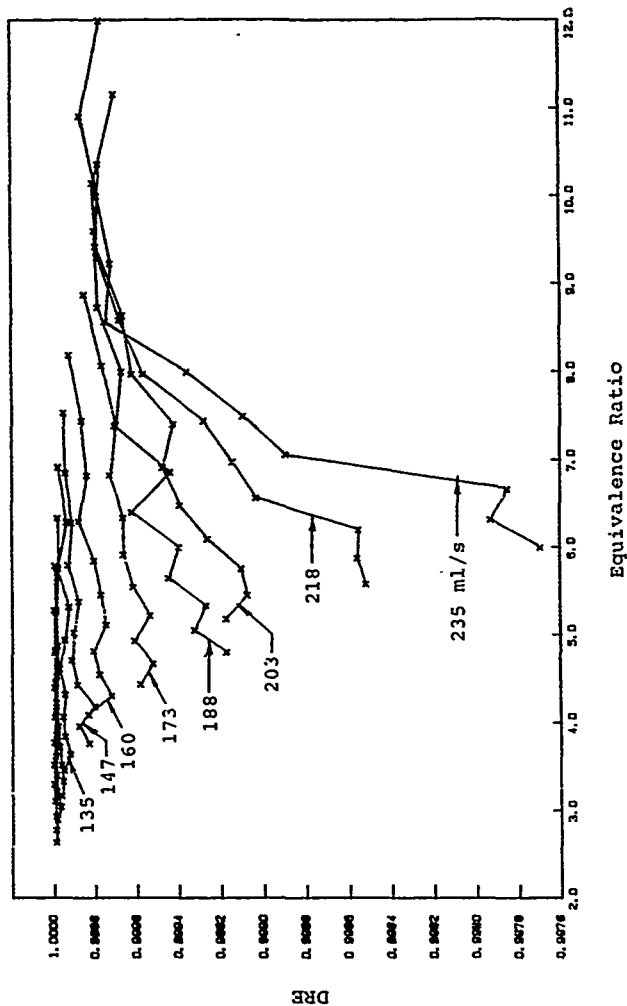
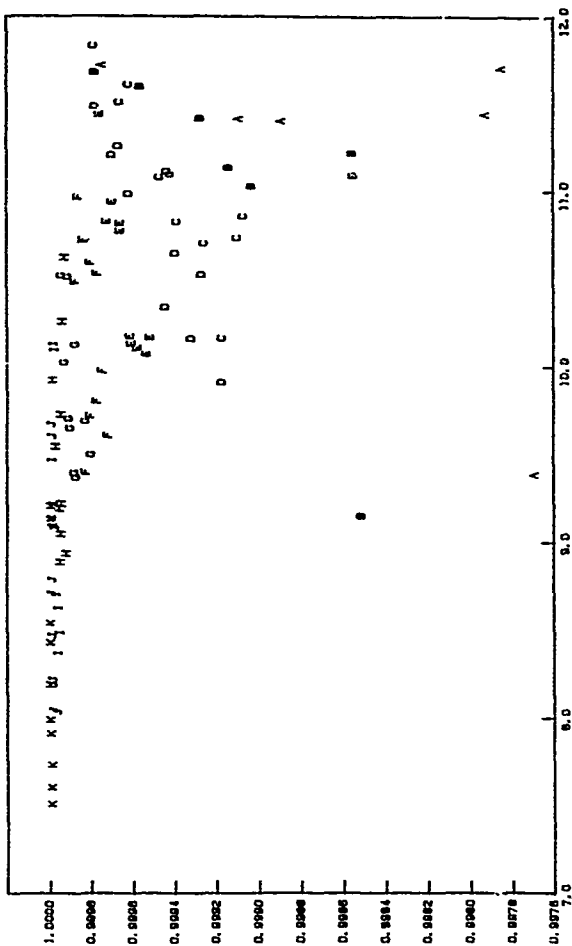

Figure 18. DRE vs. Equivalence Ratio. Lines of constant fuel flow have been connected. Higher fuel flows favor lower DREs.



Temperature at Location 10 (K) * 10⁻²

Figure 19. DRE vs. Temperature at Location 10. Location 10 is just above the flame. Letters A-K represent maximum to minimum fuel flows, respectively.

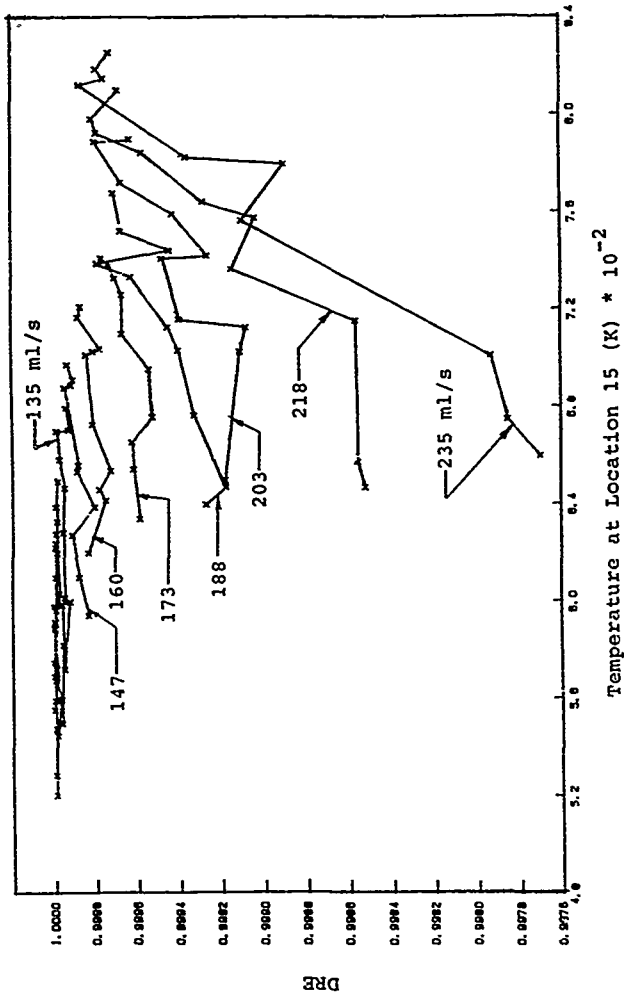

Figure 20. DRE vs. Temperature at Location 15. Location 15 gives the wall temperature of the combustion chamber. Lines have been drawn connecting points of constant fuel flow.

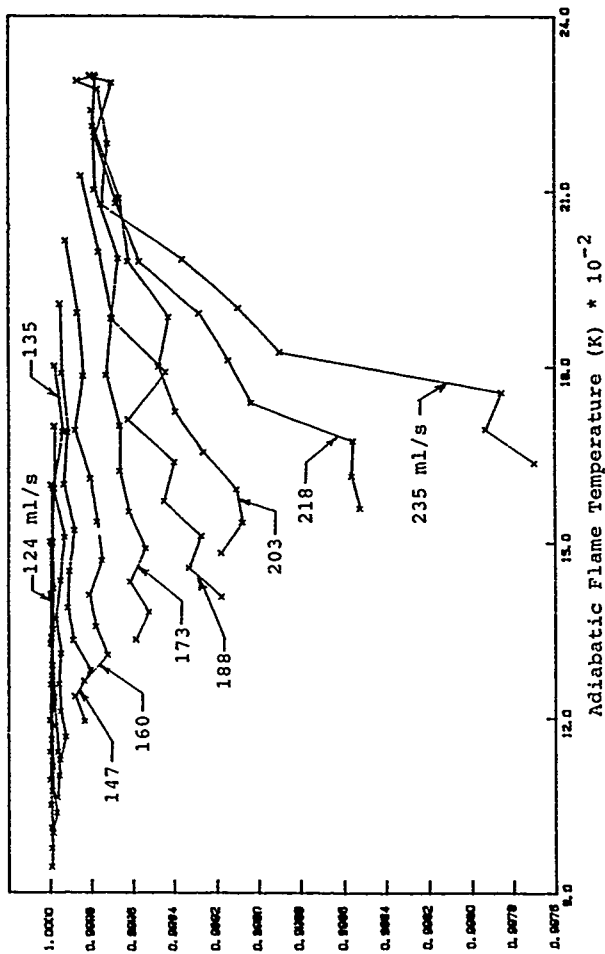

Figure 21. DRE vs. Adiabatic Flame Temperature. Lines have been drawn connecting points of constant fuel flow. Higher fuel flows favor lower DREs.

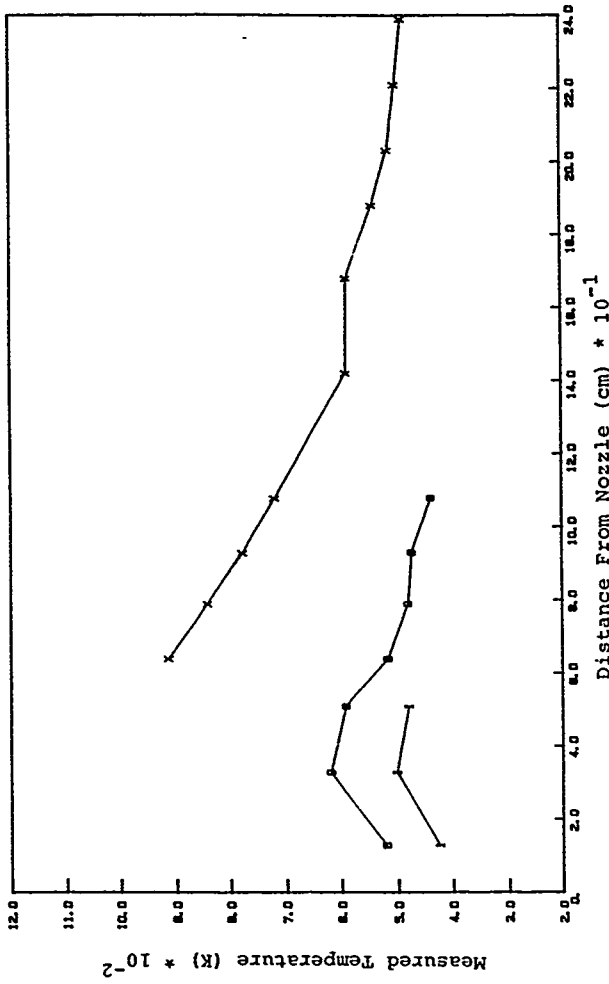

Figure 22. Temperature Profile; Minimum Fuel, Minimum Fuel. Points labeled with an X represent internal temperature measurements at Locations 1 to 10. Points labeled O and I represent surface temperature measurements at locations 11 to 17 and 18 to 20, respectively.

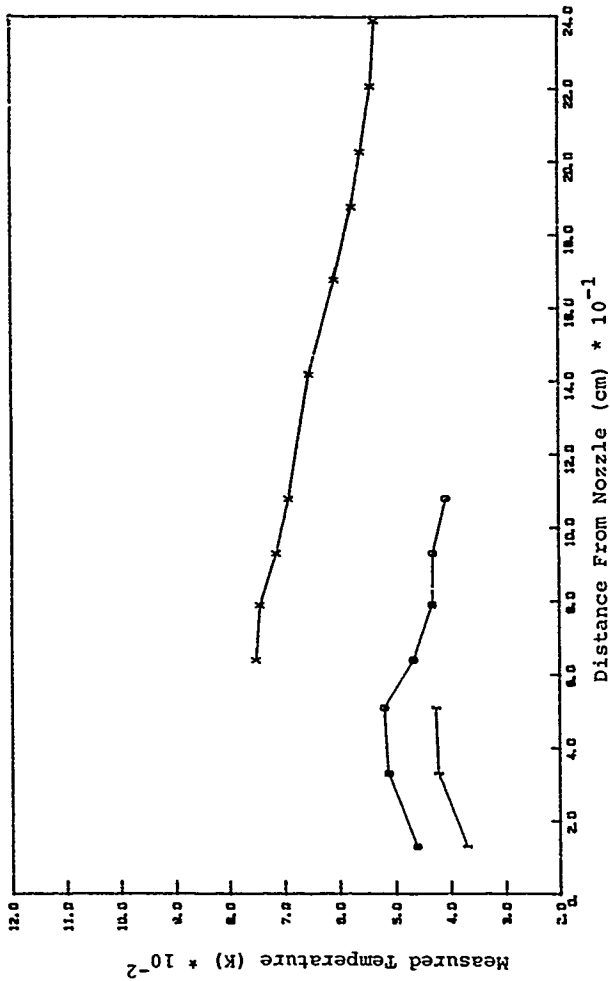

Figure 23. Temperature Profile; Maximum Air, Minimum Fuel. Points labeled with an X represent internal temperature measurements at locations 1 to 10. Points labeled O and I represent surface temperature measurements at Locations 11 to 17 and 18 to 20, respectively.

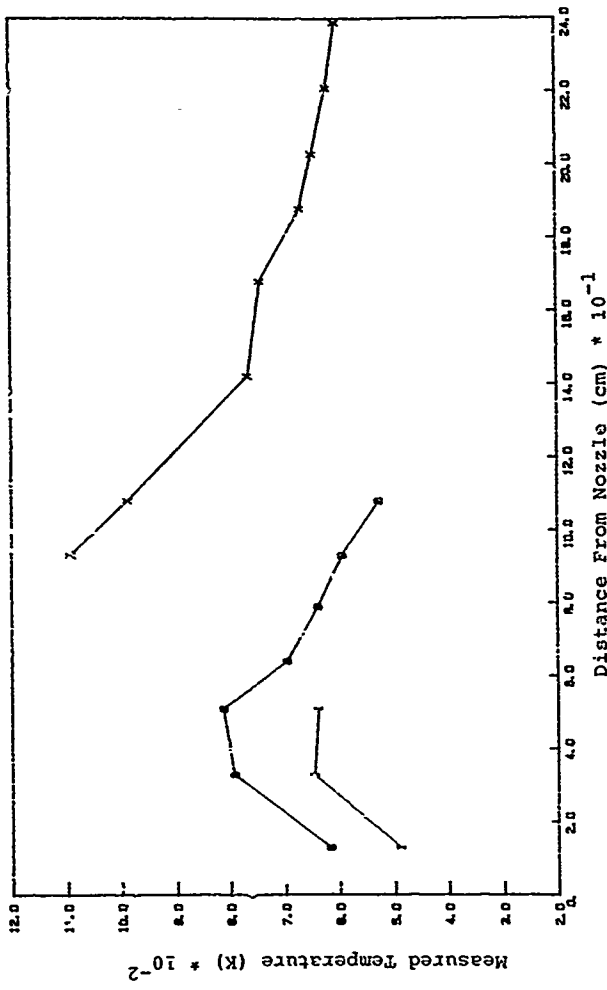

Figure 24. Temperature Profile; Minimum Air, Maximum Fuel. Points labeled with an X represent internal temperature measurements at locations 1 to 10. Points labeled O and I represent surface temperature measurements at Locations 11 to 17 and 18 to 20, respectively.

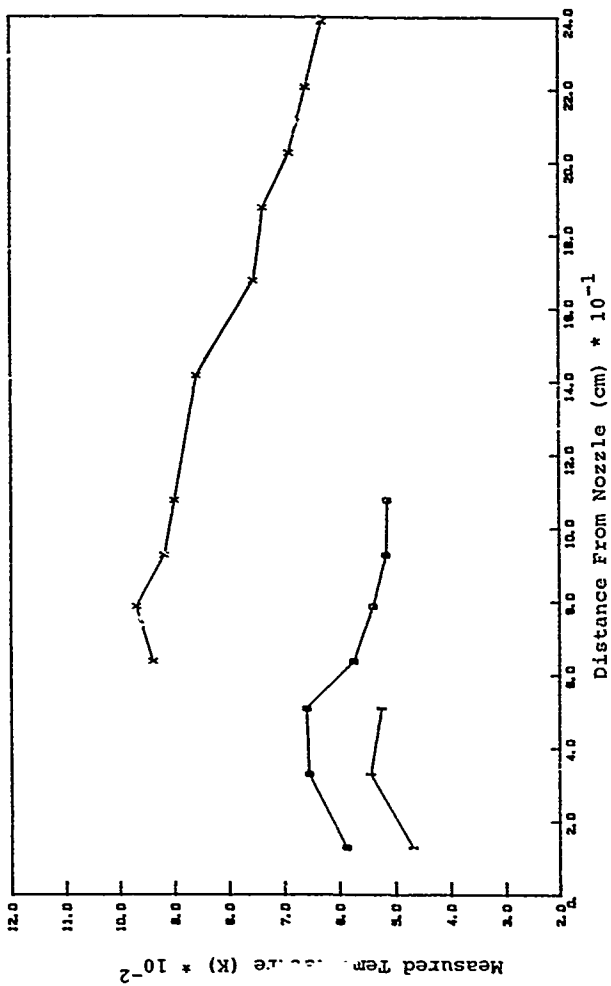

Figure 25. Temperature Profile: Maximum Air, Maximum Fuel. Points labeled with an X represent internal temperature measurements at locations 1 to 10. Points labeled O and I represent surface temperature measurements at Locations 11 to 17 and 18 to 20, respectively.

temperature at any given location in the duct allowed the calculation of the residence time and DRE up to that point, including that caused by the flame. A computer program was written to use the temperature profiles measured to calculate the postflame DRE effects. Surprisingly, there was almost no effect; the adiabatic flame temperature seemed to be the controlling factor in the SF₆ DRE. Postflame effects were many orders of magnitude lower.

A closer examination of Figure 2 and the temperature profiles of Figures 22 to 25 immediately reveals this effect. Figure 2 shows that temperatures below 900 K require over 10⁷ seconds for a DRE of 99.99 percent. Flame temperatures, on the other hand, require as little as 10⁻⁸ s for a 99.99 percent DRE. Figures 22 to 25 show that the downstream conditions are at temperatures far too low for appreciable destruction.

4. Combined Time and Temperature Effects

The previous section showed that temperature alone could not predict SF₆ destruction. Some of the figures may even be misinterpreted to suggest that poor mixing of the fuel/air/tracer mixture is the source of the poor DRE.

The one variable not quantitatively measured in this experiment was time. DRE is a function of both time and temperature and both must be considered. Starting with the basic rate equation (assuming first-order kinetics) and solving gives

$$\ln(1 - \text{DRE}) = -kt \quad (1)$$

As described earlier, time (t) is an unknown quantity. Many analyses use a residence time based on the volume of the furnace and the total flow into it as shown in the next equation (References 8 and 24).

$$t = V/Q$$

where t = mean residence time
V = volume of furnace
Q = total volume flow at furnace exit

This equation assumes complete mixing at uniform temperature of perfect gases. The first two of these conditions, especially temperature, is not rigorously satisfied in this case.

Reference 9 used the equation for time shown below.

$$t = \frac{a \cdot v}{Q(T_e - T_m)} \ln\left(\frac{T}{T_m}\right)$$

where t = residence time above temperature T , s
 V = volume of process temperature zone, ml
 Q = volumetric flow rate, ml/s
 T_e = exit temperature, K
 T_m = maximum temperature, K
 a = 294.4 K

Reference 24 has done work using the time for an inert gas (helium), to travel through the furnace. This gives total residence time in the furnace.

It is possible, however, to obtain a time value based on the gas flow rate in the combustion chamber using a slightly different approach. The time required to travel through an arbitrary volume surrounding the flame is given as

$$t = \left(\frac{F V}{R T} \right)_f \left(\frac{1}{w} \right)_i = \left(\frac{P V}{R T} \right)_f \left(\frac{R T}{P Q} \right)_i \Rightarrow \frac{C T_i}{Q_i T_f} \quad (2)$$

where t = time
 P = pressure
 R = gas constant
 T_i = inlet temperature
 T_f = adiabatic flame temperature
 V = volume
 w = mass flow rate of gas
 Q = volume flow rate of gas
 C = constant

subscripts:

f = flame zone
 i = inlet conditions

The time should be thought of as the time within an arbitrary high temperature zone surrounding the flame, rather than the time in the furnace. Also, the effect of temperature is included. The calculation of this time value would be difficult, so a characteristic time is defined in which the constant terms are all set to one. This constant will be determined later by the measured data. For the purposes of this work, the inlet temperature was also constant and treated as such in all calculations.

This method of estimating time assumes that the destruction outside an arbitrary hot zone surrounding the flame is negligible. Given that SF_6 is difficult to destroy and requires high temperatures for appreciable destruction, this is a reasonable assumption.

Using the total volumetric flow of air and fuel to calculate the characteristic time in Equation (2), and plotting the results generates Figure 26. Here DRE is shown as a function

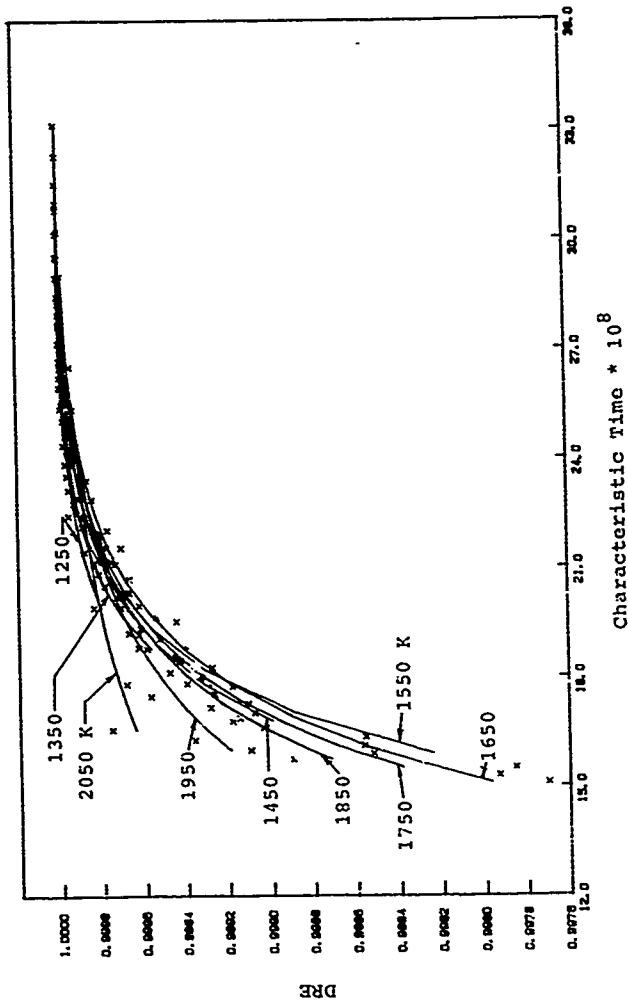

Figure 26. DRE vs. Characteristic Time (based on total flow). Lines have been drawn connecting points ± 50 K of a given adiabatic flame temperature.

of the characteristic time given by Equation (2). Points of constant adiabatic flame temperature have been connected with a least squares exponential curve fit. The results follow the expected trends except that the constant temperature lines are not all in the proper sequence.

Using the characteristic time obtained above and solving for k in Equation (1), then assuming that k is a function of the adiabatic flame temperature gives Figure 27. This figure shows no correlation of k with temperature. This can be explained by the time value as defined. The time is actually the residence time of the SF_6 in an arbitrary hot zone surrounding and including the flame. Since the SF_6 is mixed with the fuel, the time is given as the total time required for the fuel to flow through the hot zone of the flame. This time is a function of the fuel flow, flame temperature, and the volume of the hot zone of the flame. Since the flame is a diffusion flame, air flow has no effect. Only the flow entering the flame is important.

Instead of using total flow (air plus fuel) into the combustion chamber, it was decided to use fuel flow alone to calculate the characteristic time value. When fuel flow was used to calculate the characteristic time, Figure 28 was obtained. This figure shows DRE as a function of time. Data points with constant adiabatic flame temperature have been curve-fit to an exponential curve. This figure emphasizes that the higher temperatures produce higher DREs in shorter times than the lower temperatures.

Solving Equation (1) for k , as before, and assuming k is a function of the adiabatic flame temperature gives Figure 29. These data points can be curve-fit with a least squares exponential curve.

$$k(s^{-1}) = 521000 s^{-1} \exp(9.12E-4 K^{-1} * T(K)) \quad (3)$$

where k = rate constant
 T = adiabatic flame temperature

Note that the preexponential factor has absorbed the constant in the characteristic time equation.

Plotting kt versus $-\ln(1-DRE)$ gives Figure 30 which shows the fit of the data. Ideally, the slope of the least mean squares line should be one and the intercept zero. Instead, the slope is 0.94 and the intercept is 0.49 showing a slight error. The r-squared value is 0.93.

Using the k value obtained in Equation (3) above and the characteristic time based on fuel flow Equation (2) enables the prediction of DRE from Equation (1).

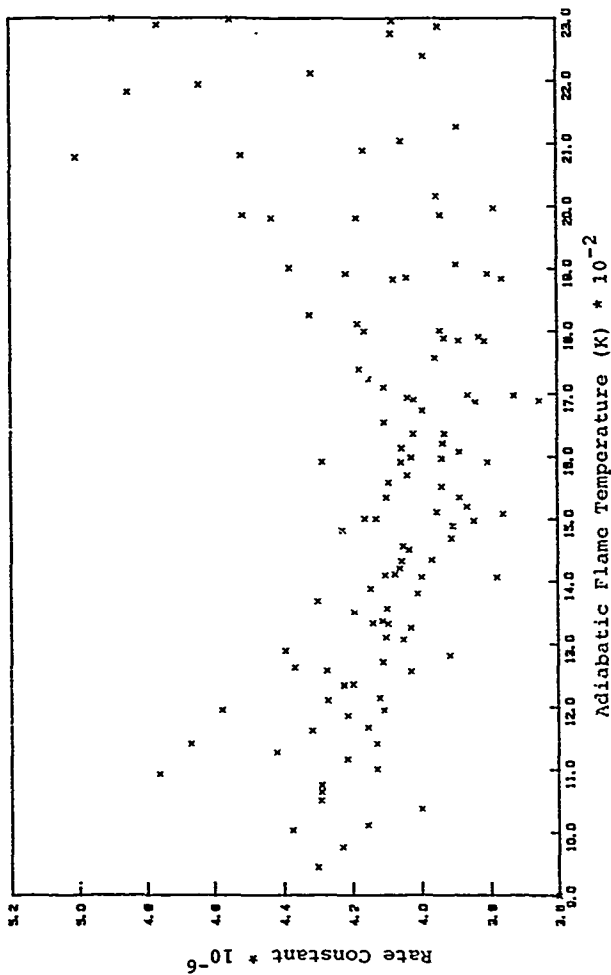

Figure 27. Rate Constant (based on total flow) vs. Adiabatic Flame Temperature.

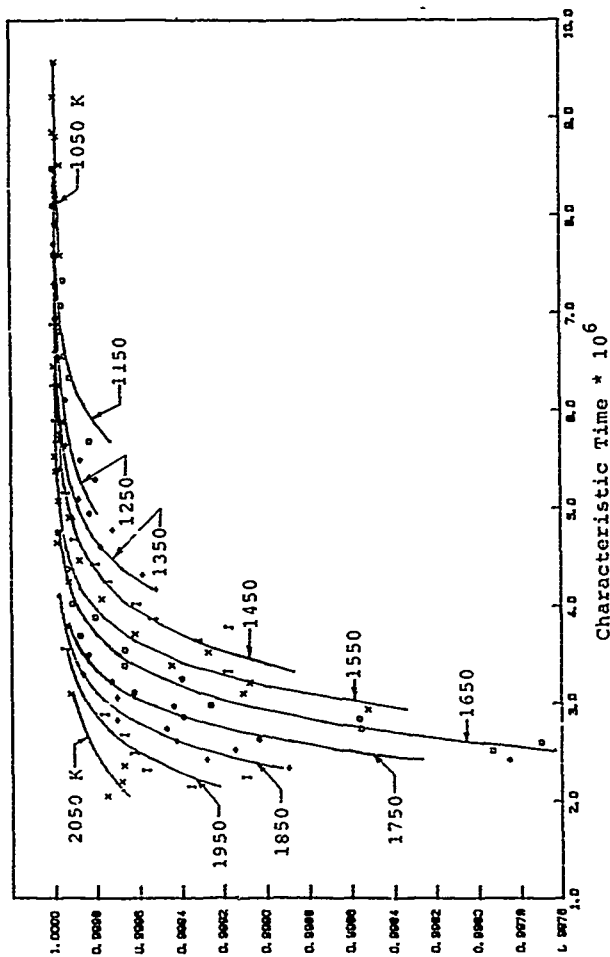

Figure 28. DRE vs. Characteristic Time (bases on fuel flow). Lines connecting data \pm 50 K of a given adiabatic flame temperature have been drawn. The higher temperatures require less time for destruction.

DRE

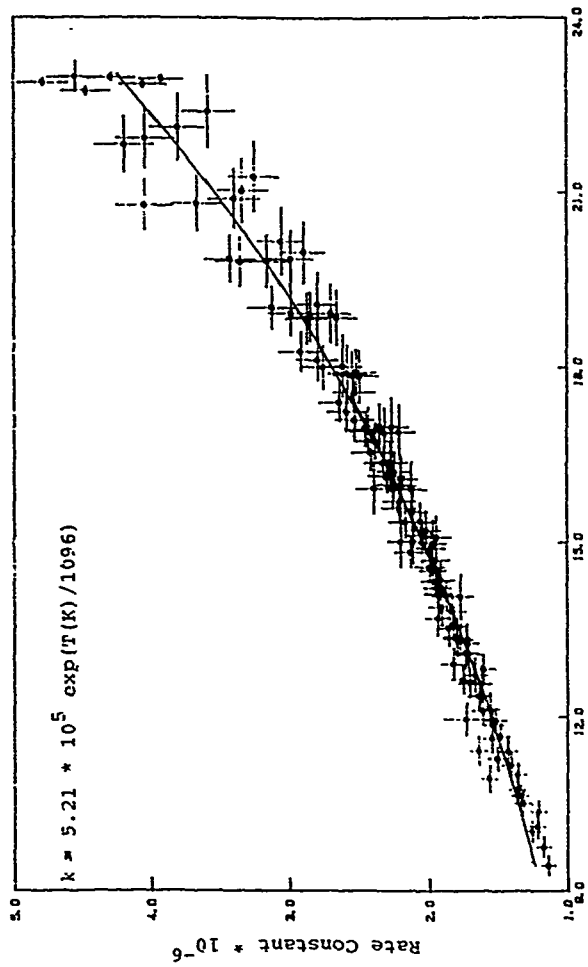

Figure 29. Rate Constant vs. Adiabatic Flame Temperature.

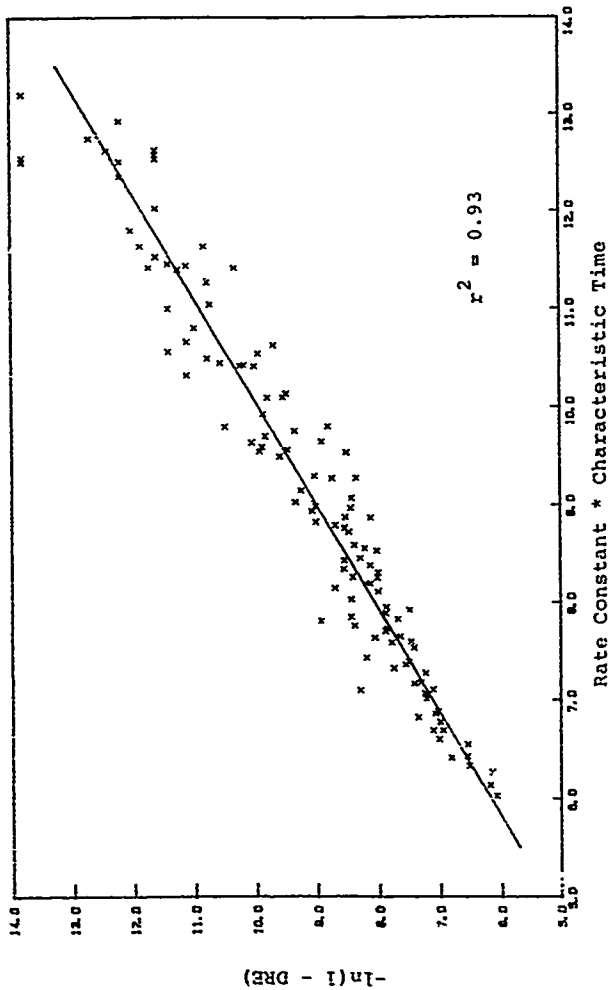

Figure 30. $-\ln(1 - \text{DRE})$ vs. Rate Constant * Characteristic Time (based on fuel flow). Error bars were shown on the previous plot and not repeated here.

$$\text{DRE} = 1 - \exp(-kt) \quad (4)$$

where $k = 521000 \text{ s}^{-1} \exp(9.12\text{E-}4 \text{ K}^{-1} * T(\text{K}))$
 $t = (\text{ml} * \text{K}) / (Q(\text{ml}/\text{s}) * T(\text{K}))$
 $T = \text{adiabatic flame temperature}$
 $Q = \text{volume flow of fuel}$

Figure 31 compares the actual DRE to that predicted using the above technique. Agreement is not perfect, but high DREs are predicted accurately. Since the purpose is not to predict DRE, but to predict failure mode operation (DREs less than 99.99 percent) of an incinerator, the above equation is more than satisfactory.

5. Review of Phase 1 Results

Comparison of the rate constant equation derived above with that reported in the literature (References 22 and 23) shows some differences.

Equation (3) $k(\text{s}^{-1}) = 521000 \text{ s}^{-1} \exp(9.12\text{E-}4 \text{ K}^{-1} * T(\text{K}))$

Reported in Literature $k(\text{s}^{-1}) = 3.16\text{E}14 \text{ s}^{-1} \exp(-46300 \text{ K} / T(\text{K}))$

An attempt was made to create a more conventional equation by plotting k vs. $1/T$ (rather than k vs. T). This produced Figure 32 and gave the equation for k below.

$$k(\text{s}^{-1}) = 8.738\text{E}6 \text{ s}^{-1} * \exp(-2075 \text{ K} / T(\text{K})) \quad (5)$$

This figure shows that this exponential curve does not fit the data as well, even though the form of the equation is more traditional. Figure 33 shows the error involved in using this value for the rate constant in Equation (1). Comparison with Figure 30 shows that the latter fits the data much better.

Note the large difference in the experimentally determined rate constant and the chemical reaction rate constant from the literature. The much lower experimental value indicates that chemistry is not the rate-controlling parameter. It is known, however, that in a turbulent diffusion flame, mixing is the rate-controlling parameter. The rate constant developed here for SF_6 is, therefore, fundamentally related to mixing.

Tracer Technologies has recently completed work of a similar nature. They injected SF_6 into a circulating bed combustor (CBC) and monitored it on a semicontinuous basis (Reference 27 and 28). SF_6 DREs of 80 percent to 99.5 percent were measured. Concentrations as low as a few ppt were made on site using routine chromatographic methods (Reference 4). Reference 28 commented on how easily and rapidly the samples were obtained.

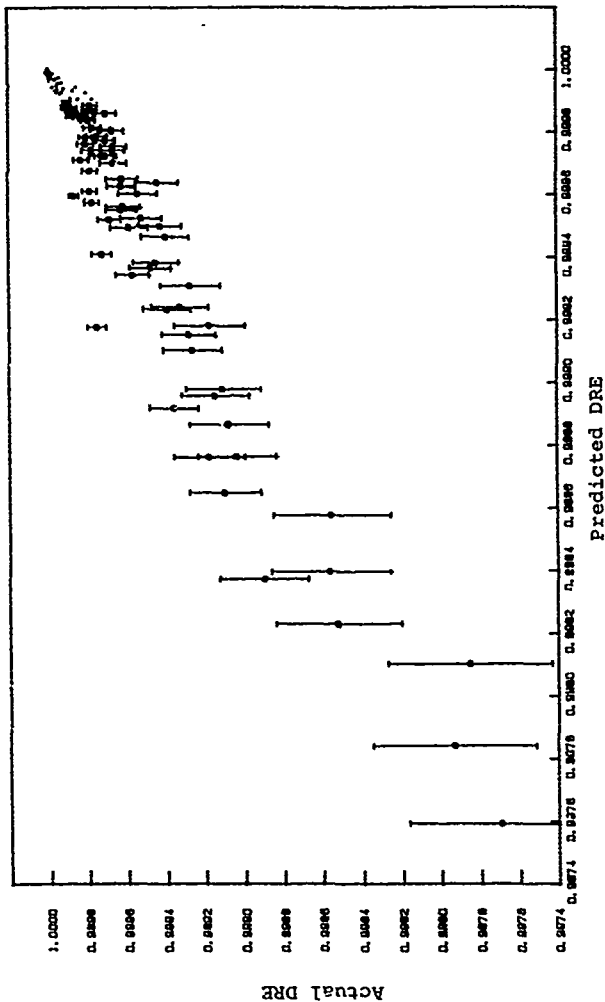

Figure 31. Actual vs. Predicted DRE. This figure shows the accuracy of the equation for DRE prediction. Error bars have been omitted for DRE values over 0.9999 for clarity of the data.

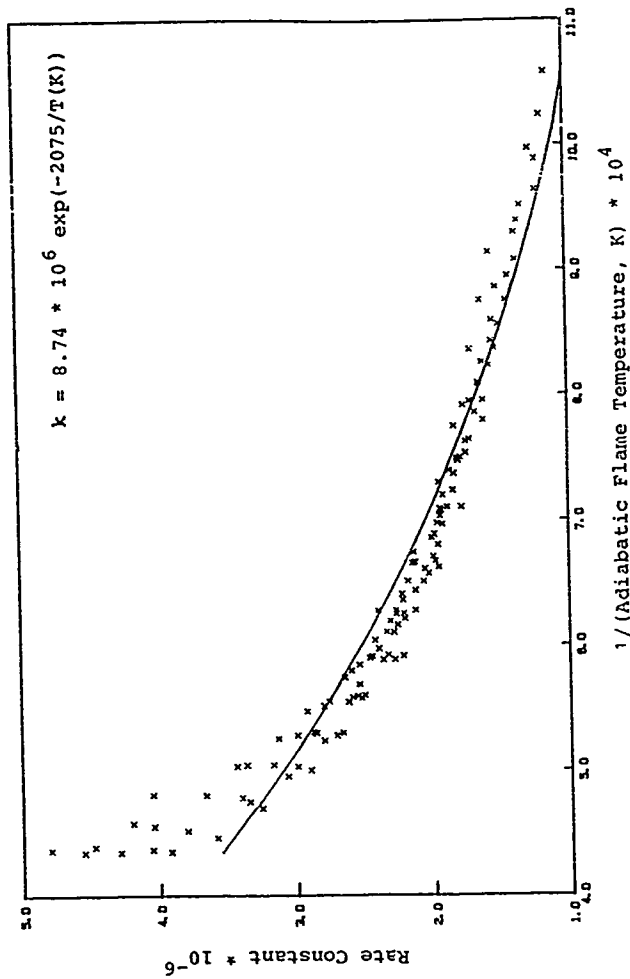

Figure 32. Rate Constant vs. $1/(Adiabatic\ Flame\ Temperature)$.

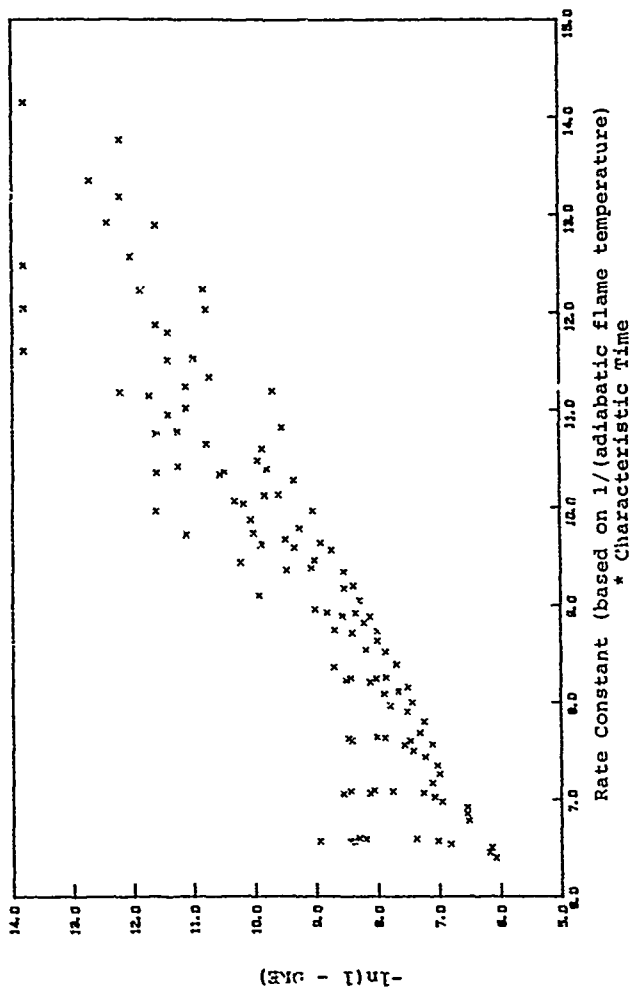

Figure 33. $-\ln(1 - DRE)$ vs. Rate Constant (based on $1/(\text{adiabatic flame temperature}) * \text{Characteristic time (based on fuel flow)}$). Note the poor fit of the data compared with Figure 30.

Another test was done at a rotary kiln where DREs greater than 99.9999 percent were obtained (Reference 4).

Their results suggest that SF₆ DRE is a function of the bed temperature only. Fuel and air flow rates apparently had no effect. They obtained the regression equation below

$$-\ln(1 - \text{DRE}) = 15990 \exp\left(\frac{-9260 \text{ K}}{T(\text{K})}\right) \quad (6)$$

Note the lack of a time value. Figure 26 shows that the characteristic time value described in this work has a definite effect on the SF₆ DRE. It would be interesting to test the proposed methods on the data described above. Perhaps a characteristic time based on total flow would work better for a CBC.

The equation for DRE prediction (Equation 4) is of the form

$$\ln(1 - \text{DRE}) = -A \exp(-BT_f) t$$

where $t = (C \cdot T_i) / (Q \cdot T_f)$
 T_f = adiabatic flame temperature
 T_i = fuel inlet temperature
 Q = volumetric fuel flow
 C = constant, set equal to one

Here A and B are constants to be determined. Theoretically, it should be possible to determine these constants using just two sets of DRE data obtained under different operating conditions (more data is recommended). The ability to predict failure mode operation with so few data would greatly reduce the time and effort required for DRE verification in incinerators and boilers.

To the naked eye, the flame appeared nearly the same under all conditions. Color photos showed, however, that the flame structure changed slightly from a closed, opaque yellow flame at the lower fuel flows to an almost open, translucent blue flame at the high fuel flow rates (Figure 6). Flame height varied slightly and air flow had no visible effect. Pockets of burning gases escaping the main body of the flame and rising upward were occasionally observed under all flame conditions.

The only visible effect was near the flame-stabilizing ball above the nozzle. At low fuel flows the flame engulfed the ball; however, at high fuel flows (high jet velocities) the flame rose above the ball. This effect can be seen in Figure 6. The dead air space surrounding the combustion chamber appeared to do its job, keeping the wall temperature as high as possible.

Overall, 42 percent of the DRE measurements were over the 99.99 percent level. Figure 34 shows the distribution of the measurements. The lowest DREs occurred at the highest fuel flows

(shortest characteristic times) and the highest air flows (lower adiabatic flame temperatures due to excess air).

C. PHASE 2 DATA ANALYSIS

1. Initial Analysis

A computer program similar to that developed earlier was used for the data analysis (Appendix D). Some simplifying assumptions were made in analyzing the combustion chemistry. Assuming dry inlet air, complete combustion, and no condensation of water in the exhaust, the chemical equation for combustion becomes



The values for a and b were obtained from the fuel composition and flow rate. The variables, c and d, were obtained from the air flow rate. To test the validity of these assumptions, the experimental data from the first phase were analyzed with the program developed using these simplifying assumptions; the final results were within 3 percent of the values obtained using the more detailed chemical analysis.

Uncertainty calculations were not repeated for this analysis. The adiabatic flame temperature was calculated using the subroutine in Appendix C.

2. Problems With Waste Detection

Detection of the surrogate wastes in the exhaust was very difficult, even with the FID adjusted to its greatest sensitivity. Detection of toluene in the exhaust was never achieved as the concentrations in the exhaust were below the detection limit of the GC. This indicates that the destruction level of toluene in the burner was very high; however, no attempt was made to quantify the toluene destruction level other than to observe that it was greater than 99.99 percent.

Methylene chloride also presented a problem. No attempt was made to measure the amount of the surrogate wastes added to the fuel supply. However, by knowing the saturation pressure and fuel supply temperature it was estimated that the fuel line contained approximately 5 percent waste after bubbling through the liquid waste. Even at these low concentrations, methylene chloride prevented the fuel from igniting. An attempt was made to reduce the amount of methylene chloride evaporating into the fuel line by having the fuel pass only through the methylene chloride vapors. This method proved unsatisfactory because the low concentrations in the exhaust were undetectable. As a result, no further attempt was made to quantify the destruction levels of methylene chloride in this experiment.

The benzene and the trichloroethylene were successfully detected in the exhaust, but not at all run conditions. Benzene was detected during nine different experimental runs; trichloroethylene was detected during 16 different experimental runs.

D. PHASE 2 RESULTS

The analyzed SF₆ data were compared to the results obtained in the first phase of the experiment. The analyzed surrogate waste data were compared to the SF₆ data obtained in this phase of the experiment. The semiempirical parameters used in analyzing the data were those developed in the first phase.

In analyzing the first phase experimental data a relationship for SF₆ DRE as a function of a semiempirical mixing rate was developed. This relationship accounts for the effects of time, temperature, and mixing on SF₆ DRE

$$\ln(1 - \text{DRE}) = -kt$$

where $k = Ae^{(T_{ad}/B)}$, mixing rate constant, (ml*K/s)
 $t = 1/(Q_f * T_{ad})$, characteristic time, (ml*K/s)⁻¹
 T_{ad} = overall adiabatic flame temperature, (K)
 Q_f = volume flow rate of fuel, (ml/s)

The values, A and B, are mixing parameters and should vary only as a function of burner geometry. The product, kt, is a representation of flame conditions; it is effectively a function of fuel flow, air flow, and fuel composition.

1. Mixing

The mixing rate constant, as defined above, was determined using the SF₆ data from this experiment. It is plotted as a function of the adiabatic flame temperature in Figure 35. Also shown is the curve obtained with the 1/2-inch flame holder from the first phase. The analyzed data from this part of the experiment also fit an exponential curve, but with different constants. The exponential equations are given in Figure 35.

2. Destruction Removal Efficiency

The DRES of both benzene and trichloroethylene are plotted in Figure 36 as a function of the product, kt, developed from the SF₆ data. The product kt is nothing more than a complex function of the fuel and air flow rates, for a given fuel type. As such, it provides a good axis for plotting DRE data.

The DRES of both the benzene and the trichloroethylene were greater than 99.99 percent in all cases. Also, in all cases, their DRES were greater than that of the SF₆.

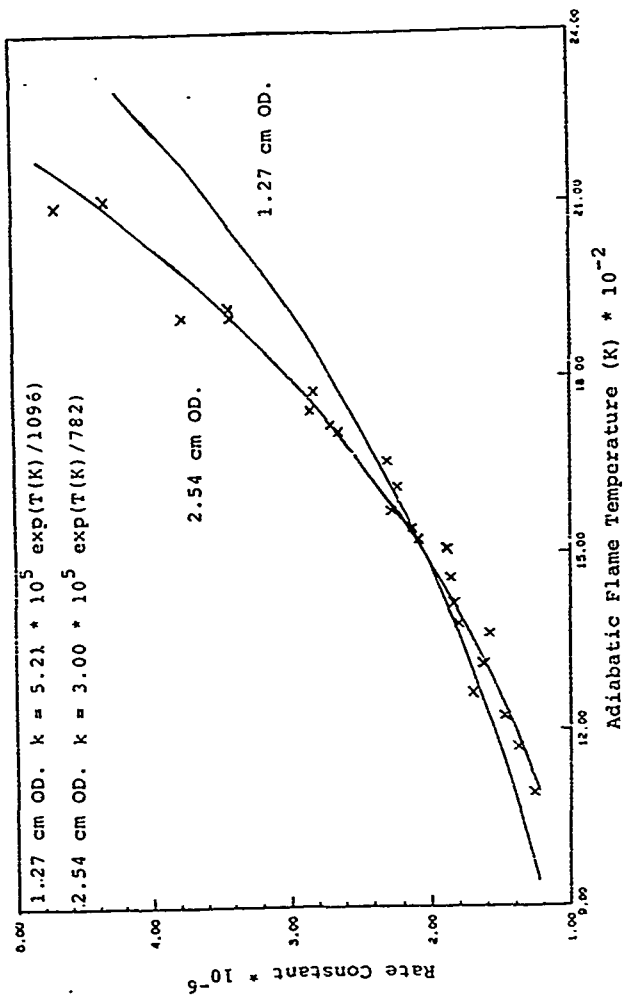

Figure 35. Rate Constant vs. Adiabatic Flame Temperature With Flame Holder Diameters of 1.27 cm and 2.54 cm. Data for the 2.54 cm flame holder are included. Data for the 1.27 cm flame holder are shown in Figure 29.

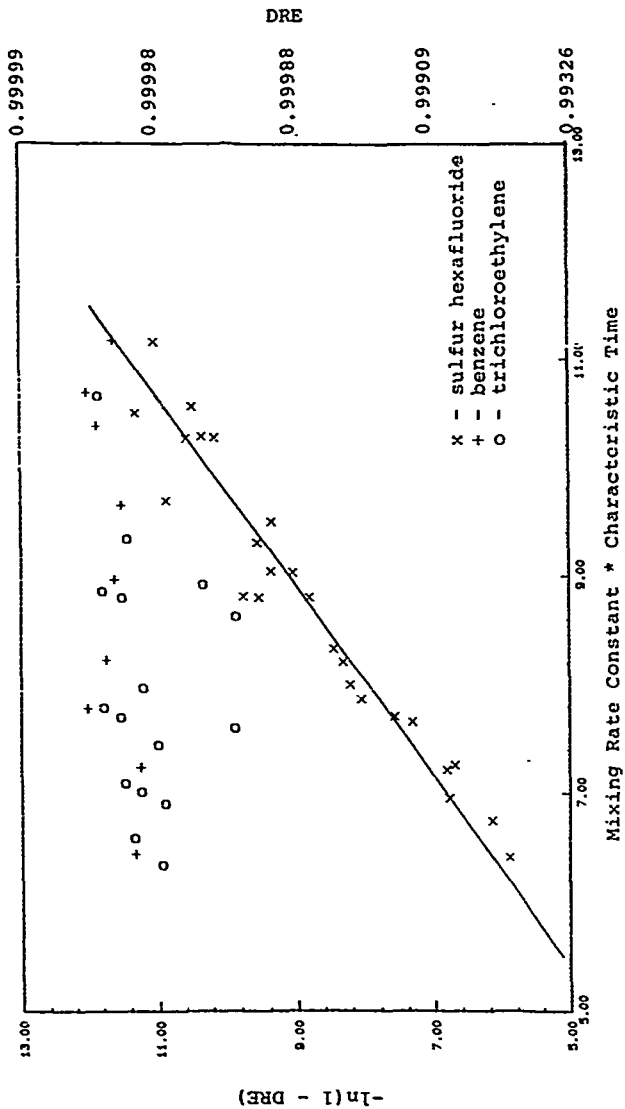

Figure 36. $-\ln(1 - \text{DRE})$ vs. Mixing Rate (based on SF_6 data) * Characteristic Time, for Sulfur Hexafluoride, Benzene, and Trichloroethylene. In all cases, the DRE of benzene and trichloroethylene was greater than the DRE of SF_6 .

SECTION VI

CONCLUSION

A. REVIEW OF RESULTS

The results of the first part of the experiment show that temperature alone can not predict DRE. Higher temperatures produce higher DREs, but only when considering the same time scales. Time alone cannot be used either. Both time and temperature are important in the analysis of DRE.

Forty-two percent of the first phase SF₆ DRE measurements were above the 99.99 percent level. The large number of failure mode measurements was due to the wide range of operating conditions possible in the laboratory burner. This permitted analysis of a wide range of carefully controlled conditions that would be difficult to maintain in a full-sized furnace. The lowest DREs occurred at the highest fuel flows (shortest characteristic time values) and the highest air flows (lowest temperatures due to excess air). Also, combustion chamber wall temperature had no effect on DRE; but, since SF₆ is a gas, impingement on walls is not a serious problem.

Postflame effects were found to have a negligible effect on the SF₆ DRE. Many wastes that are difficult to destroy would probably follow this trend, therefore, postflame effects should be ignored for wastes of this type.

B. SULFUR HEXAFLUORIDE AS A TRACER

For all the experimental runs from which data were obtained in the second part of the experiment, the DREs of benzene and trichloroethylene were greater than the DREs of SF₆. This indicates that SF₆ is more difficult to destroy than benzene and trichloroethylene, when burned in the same environment. This supports the contention that SF₆ would be good tracer for these waste compounds. Although toluene DREs were not determined, the high toluene destruction levels indicate that SF₆ would also be a good tracer for toluene.

The surrogate wastes were prevaporized and burned with natural gas. This experiment demonstrates that SF₆ is suitable for use as a tracer for these wastes when burned under these conditions. However, its suitability for use as a tracer for liquid wastes burned with liquid fuels remains to be determined.

No correlation could be drawn between SF₆ DRE and methylene chloride DRE. The bond energy of methylene chloride is 99 kcal/mol; the bond energy of sulfur hexafluoride is 92 kcal/mol. Methylene chloride may be one of the few partially combustible compounds that is more stable than SF₆. Due to the energy required for methylene chloride incineration, a comparison of SF₆

DRE and methylene chloride DRE must be conducted in a larger burner.

C. SULFUR HEXAFLUORIDE AND MIXING

The only parameter altered by changing the flame holder in the second part of the experiment was the mixing conditions within the burner. The change in the SF_6 reaction rate indicates that the reaction rate is related to mixing. Additional burns with different flame holders are required to confirm these preliminary results.

The higher DRE values of benzene and trichloroethylene indicate that mixing is not the only rate-controlling parameter. The mixing conditions for the waste burns were the same as for the SF_6 burns; the only parameter affected was the chemical reaction rate, which differs for each compound. Whether the higher DREs were a result of higher reaction rates within the flame, or a result of decomposition beyond the flame remains to be determined. It was verified in the first phase, however, that there was no further decomposition of SF_6 beyond the flame zone. The temperatures downstream of the flame zone ranged from 600 to 1100 K. While these temperatures were not sufficient for further SF_6 decomposition, they may have been sufficient for further decomposition of the less stable compounds.

Although preliminary, these results indicate that the overall reaction rate affecting DRE is a function of mixing and chemistry, but is dominated by mixing. For the case of burning liquid wastes, the rate of vaporization of the fuel would also become a factor. An important result of this experiment is that the mixing rate dominates SF_6 DRE. In other words, postflame chemistry has no effect on SF_6 DRE. This suggests that SF_6 may be used as an indicator of mixing in a turbulent diffusion flame.

D. PRACTICAL APPLICATIONS

Use of the semiempirical equation (Equation (4), Section V) requires the determination of two constants. This could, theoretically, be done by taking just two DRE measurements under different conditions (more data are recommended). Following this procedure for an incinerator or boiler would allow prediction of failure mode operating conditions with a minimum of testing.

If SF_6 is used as a tracer in the above procedure, as done in this work, the tests become simple. SF_6 is very easy to detect and is difficult to destroy. Since it is more difficult to destroy than most waste materials, the prediction of failure mode operation would be a conservative one, assuring greater than 99.99 percent destruction for all less thermally stable POHCs. Use of sulfur hexafluoride as a tracer with the analysis techniques described, could save considerable time and effort in DRE verification.

SECTION VII

RECOMMENDATIONS

A. IMPROVING PHASE 2 OF THE EXPERIMENT

Although this experiment was useful in establishing relative DRE values for SF₆ and several typical wastes, it provided insufficient data to establish definite trends. The main problem was the inability to detect the low concentrations of the surrogate wastes in the exhaust. Also, accuracy is compromised when operating the GC/FID at its greatest sensitivity. These problems could be overcome by concentrating the sample. This would require measuring the exhaust flow rate, which should not be difficult.

Using the ECD for the detection of the chlorinated compounds would also increase detection capabilities. The molecular sieve column connected to the ECD was not suitable for use with the surrogate wastes of this experiment. Adaptation of the wide-bore capillary column for use with the ECD would allow it to be used to detect the chlorinated compounds.

Determination of DRE by relating area measurements is suitable for first approximations; however, suitable calibration curves are required for accurate results. Calibration standards are commercially available or may be developed in the lab.

Control of the waste input into the burner should be improved. Perhaps the use of commercially available gaseous samples would give better flow control.

The SF₆ and the wastes should be burned simultaneously to insure that they all see the same burner environment. This requires adapting the GC to operate with both the ECD and the FID. As mentioned, this modification has since been completed.

B. TRIALS IN FULL-SIZED INCINERATORS AND BOILERS

SF₆ DRE data should be obtained for a full-sized incinerator or boiler and analyzed, using the methods developed here. The characteristic time value obtained for the laboratory burner depended on both the adiabatic flame temperature and fuel flow rate. Total flow, rather than fuel flow, might work better for flames that are not diffusion-controlled. Also, the actual flame temperature may give more accurate results. The mixing rate constant was found to depend on the adiabatic flame temperature. The actual flame temperature might work better in an incinerator/boiler.

Tracer and POHC DRES need to be compared in a full-size unit. A 99.99 percent DRE for a given POHC may correspond to less than 99.99 percent DRE for a given tracer. This is expected; however, the requirement of a 99.99 percent DRE for a

tracer that is difficult to destroy (such as SF₆) may be too conservative. For instance, a DRE of 99.00 percent for SF₆ may be the equivalent of a 99.99 percent DRE for a less thermally stable species. A lower tracer DRE may be sufficient for many POHCs.

Finally, although this experiment was valuable in establishing trends and creating a basis for developing SF₆ tracer technology, additional research is required to determine the suitability of sulfur hexafluoride as a tracer for liquid waste/liquid fuel incineration in a boiler environment.

These topics need further study. University of Florida boilers have been used for similar research (References 45 and 46) and may provide an excellent opportunity for full-scale testing.

C. DUAL-TRACER TECHNIQUE

Dual-tracer studies should be initiated. Dual-tracer DRE measurements would permit accurate DRE measurements without knowing fuel flow, air flow, or exhaust composition. Only the ratio of the two tracers before and after incineration needs to be known. Increased accuracy would be an added benefit of this method (limited only by the accuracy of the ratio measurements).

The dual-tracer concept can be used with the characteristic time and empirical mixing rate constant approach discussed earlier. Work should continue towards developing a simple, inexpensive method of testing incinerators and boilers for their incineration abilities, and in developing a simple relationship to predict DRE.

D. MIXING RATE

Experimental research should be conducted to establish the relative effects of mixing, chemistry, and evaporation on DRE. Also, the use of SF₆ as an indicator of mixing should be further investigated.

E. INCINERATION OF CHLORINATED COMPOUNDS

While burning trichloroethylene, detectable amounts of chlorine and acid were released. This problem also occurs when burning chlorinated compounds in boilers and incinerators not equipped with scrubbers. Chlorine and hydrochloric acid formation must be considered when burning chlorinated compounds.

APPENDIX A

PROGRAM TO ANALYZE PHASE 1 SF6 DATA

```

C.....D(AIR,FUEL,K)
C.....D CONTAINS ALL INPUT AND CALCULATED DATA
C.....NEWDAT CONTAINS INPUT DATA ONLY AND IS OF
C..... THE SAME FORM AS D.
C.....THE VARIABLES IN D ARE NAMED IN SUBROUTINE
C..... STOICH.
C.....
C.....AIR=5*I+45
C.....FUEL=-J+21
C.....
C.....
      DIMENSION D(11,11,44),WW(9)
      REAL NCOUNC,N1CO,N2CO
      OPEN(1,FILE="NEWDAT")
      READ(1,*)((D(I,J,K),K=1,13),J=1,11),I=1,11)
      CLOSE(1)
C.....
C.....
C.....INITIALIZE UNCERTAINTY OF VARIABLES
C.....
C.....UNCERTAINTY OF AIRROT
      WW(1)=2.
C.....UNCERTAINTY OF GASROT
      WW(2)=0.2
C.....UNCERTAINTY OF PPMCO
      WW(3)=20
C.....UNCERTAINTY OF SF6FLO (ML/S)
      WW(4)=0.004
C.....UNCERTAINTY OF W (MASS H2O VAPOR/MASS DRY AIR)
      WW(5)=0.0004
C.....UNCERTAINTY OF PAMB (MM HG)
      WW(6)=0.5
C.....UNCERTAINTY OF PSAT (MM HG)
      WW(7)=5
C.....UNCERTAINTY OF SF6FIN (AREA COUNTS)
C.....WW(8)=SF6FIN*0.25
C.....UNCERTAINTY OF TAMB (DEGREES KELVIN)
      WW(9)=4
C.....
      DO 10 I=1,11
      DO 5 J=1,11
C.....UNCERTAINTY OF SF6 AREA
      WW(8)=0.25*DAT(I,J,8)
C.....

```

C.....CALCULATE UNCERTAINTY AT I,J

C.....

DREUNC=0.
DRECUN=0.
NCOUNC=0.
EAUNC=0.
O2UNC=0.
TADUNC=0.
AFUNC=0.
PHIUNC=0.

C.....

DO 4 K=1,9
YY=D(I,J,K)
YY2=D(I,J,K)
IF(K.EQ.3.AND.YY.LE.0) YY=0.5
XX=YY*0.01
D(I,J,K)=YY-XX

C.....

CALL STOICH(D(I,J,2),D(I,J,1),D(I,J,3),D(I,J,12),
&D(I,J,9),D(I,J,11),D(I,J,10),D(I,J,8),D(I,J,4),
&D(I,J,13),D(I,J,5),D(I,J,6),D(I,J,7),D(I,J,14),
&D(I,J,15),D(I,J,16),D(I,J,20),D(I,J,19),D(I,J,21),
&D(I,J,23),D(I,J,24),D(I,J,22),D(I,J,29),D(I,J,26),
&D(I,J,27),D(I,J,28),D(I,J,30),D(I,J,33),D(I,J,34),
&D(I,J,35),D(I,J,17),D(I,J,18),D(I,J,31),D(I,J,32),
&D(I,J,25),D(I,J,43))

C.....

DRE1=D(I,J,35)
DREC1=D(I,J,43)
N1CO=D(I,J,20)
EA1=D(I,J,30)
O2CAL1=D(I,J,32)
TAD1=D(I,J,33)
AFACT1=D(I,J,26)
PHI1=D(I,J,28)
D(I,J,K)=YY+XX

C.....

CALL STOICH(D(I,J,2),D(I,J,1),D(I,J,3),D(I,J,12),
&D(I,J,9),D(I,J,11),D(I,J,10),D(I,J,8),D(I,J,4),
&D(I,J,13),D(I,J,5),D(I,J,6),D(I,J,7),D(I,J,14),
&D(I,J,15),D(I,J,16),D(I,J,20),D(I,J,19),D(I,J,21),
&D(I,J,23),D(I,J,24),D(I,J,22),D(I,J,29),D(I,J,26),
&D(I,J,27),D(I,J,28),D(I,J,30),D(I,J,33),D(I,J,34),
&D(I,J,35),D(I,J,17),D(I,J,18),D(I,J,31),D(I,J,32),
&D(I,J,25),D(I,J,43))

C.....

D(I,J,K)=YY2
DRE2=D(I,J,35)
DREC2=D(I,J,43)
N2CO=D(I,J,20)
EA2=D(I,J,30)
O2CAL2=D(I,J,32)
TAD2=D(I,J,33)
AFACT2=D(I,J,26)

```

      PHI2=D(I,J,28)
C.....
DREUNC=DREUNC+((DRE2-DRE1)/(2.*XX)*WW(K))**2
DRECUN=DRECUN+((DREC2-DREC1)/(2.*XX)*WW(K))**2
NCOUNC=NCOUNC+((N2CO-N1CO)/(2.*XX)*WW(K))**2
EAUNC=EAUNC+((EA2-EA1)/(2.*XX)*WW(K))**2
O2UNC=O2UNC+((O2CAL2-O2CAL1)/(2.*XX)*WW(K))**2
TADUNC=TADUNC+((TADI2-TADI1)/(2.*XX)*WW(K))**2
AFUNC=AFUNC+((AFACT2-AFACT1)/(2.*XX)*WW(K))**2
PHIUNC=PHIUNC+((PHI2-PHI1)/(2.*XX)*WW(K))**2
4
CONTINUE
C.....
D(I,J,36)=DREUNC**0.5
D(I,J,44)=DRECUN**0.5
D(I,J,37)=NCOUNC**0.5
D(I,J,38)=EAUNC**0.5
D(I,J,39)=O2UNC**0.5
D(I,J,40)=TADUNC**0.5
D(I,J,41)=AFUNC**0.5
D(I,J,42)=PHIUNC**0.5
C.....
C.....CALCULATE ACTUAL VALUES
C.....
      CALL STOICH(D(I,J,2),D(I,J,1),D(I,J,3),D(I,J,12),
&D(I,J,9),D(I,J,11),D(I,J,10),D(I,J,8),D(I,J,4),
&D(I,J,13),D(I,J,5),D(I,J,6),D(I,J,7),D(I,J,14),
&D(I,J,15),D(I,J,16),D(I,J,20),D(I,J,19),D(I,J,21),
&D(I,J,23),D(I,J,24),D(I,J,22),D(I,J,29),D(I,J,26),
&D(I,J,27),D(I,J,28),D(I,J,30),D(I,J,33),D(I,J,34),
&D(I,J,35),D(I,J,17),D(I,J,18),D(I,J,31),D(I,J,32),
&D(I,J,25),D(I,J,43))
5
CONTINUE
10
CONTINUE
C.....
C.....WRITE RESULTS TO FILE
C.....
      OPEN(2,FILE='ANALYZEDDATA')
      WRITE(2,*)((D(I,J,K),K=1,44),J=1,11),I=1,11)
      CLOSE(2)
      STOP
      END

```

APPENDIX B

SUBROUTINE STOICH

C.....PROGRAM TO DETERMINE STOICHIOMETRIC EQUATION, EXCESS AIR,
 C.....AF RATIO, EQUIVALENCE RATIO, THEORETICAL AIR, AND DRE
 C.....
 C.....VARIABLES:
 C..... GASROT = FUEL ROTAMETER VALUE
 C..... AIRROT = AIR ROTAMETER VALUE
 C..... PPMCO = PPM CARBON MONOXIDE
 C..... O2PCT = PERCENT OXYGEN (BY ANALYZER)
 C..... TAMB = AMBIENT TEMPERATURE
 C..... TEXH = EXHAUST TEMPERATURE
 C..... TSMPL = SAMPLE TEMPERATURE
 C..... SF6FIN = SF6 PEAK AREA MEASUREMENT
 C..... SF6FLO = SF6 FLOW RATE
 C..... O2FINL = OXYGEN PEAK AREA MEASUREMENT
 C..... W = MASS OF WATER VAPOR/MASS DRY AIR
 C..... PAMB = AMBIENT PRESSURE
 C..... PSAT = SATURATION PRESSURE OF WATER AT TSMPL
 C..... NCH4 = MOLES CH4, ETC.
 C..... TA = THEORETICAL AIR
 C..... AFACT = ACTUAL AIR FUEL RATIO
 C..... AFSTOI = STOICHIOMETRIC AIR FUEL RATIO
 C..... PHI = EQUIVALENCE RATIO
 C..... EA = EXCESS AIR
 C..... TADI = ADIABATIC FLAME TEMPERATURE
 C..... DRE = DRE OF SF6 (NOT CORRECTED FOR LEAK)
 C..... GCO2 = PERCENT O2 FROM GC AREA MEASUREMENTS
 C..... O2CALC = CALCULATED PERCENT OXYGEN FROM INPUT DATA
 C..... SOOT = SOOT FORMED IN FLAME
 C..... DRECOR = DRE OF SF6 (CORRECTED FOR AIR LEAK)
 C.....
 SUBROUTINE STOICH(GASROT,AIRROT,PPMCO,O2PCT,TAMB,TEXH,
 &TSMPL,SF6FIN,SF6FLO,O2FINL,W,PAMB,PSAT,NCH4,NC2H6,NO2R,
 &NCO,NCO2,NO2P,NH2OPV,NH2OPL,NN2P,TA,AFACT,AFSTOI,PHI,
 &EA,TADI,QLOSS,DRE,NN2R,NH2OR,GCO2,O2CALC,SOOT,DRECOR)
 C.....
 REAL NCH4,NC2H6,NO2R,NN2R,NCO,NCO2,NO2P,NH2OR,
 &NH2OPV,NH2OPL,NN2P,NH2OP,NSF6P
 C.....
 C..... EQN TO CALCULATE FUEL FLOW (ML/S),VALID FROM 10 TO 20
 C..... ON FUEL ROTAMETER
 FUELFL=42.75+2.50438*GASROT+0.354184*GASROT**2
 C.....
 C..... EQN TO CALC AIR FLOW (ML/S)
 AIRFLO=38.13*AIRROT
 C.....
 SF6CON=SF6FLO/(FUELFL+AIRFLO)*1.E09
 NCH4=.976*FUELFL
 NC2H6=.024*FUELFL
 C..... W=MASS OF H2O VAPOR/MASS OF DRY AIR

NH2OR=1.6077*W*AIRFLO/(1+1.6077*W)
 DRYAIR=AIRFLO-NH2OR
 NO2R=.2099*DRYAIR
 NN2R=.7901*DRYAIR
 NN2P=NN2R

C.....
 C.....ASSUME NO CONDENSATION OF WATER VAPOR

C.....
 NH2OPV=2*NCH4+3*NC2H6+NH2OR
 NCO=PPMCO/(2.E06-PPMCO)*(2.*NN2R+NH2OPV+2.*NO2R+NH2OR)
 NCO2=NCH4+2.*NC2H6-NCO
 NO2P=(2.*NO2R+NH2OR-2.*NCO2-NCO-NH2OPV)/2.
 PH2O=NH2OPV*PAMB/(NH2OPV+NN2P+NO2P+NCO+NCO2)
 NH2OPL=0.
 IF(PH2O.LE.PSAT)GOTO 500

C.....
 C.....IF CONDENSATION OCCURS (PH2O .GT. PSAT)

C.....
 R=1.-PAMB/PSAT
 IF(PPMCO.NE.0)GOTO 50
 NCO=0.
 GOTO 60
 50 NCO=((1.-R)/2.*{2.*NO2R-2.*NCH4-3.*NC2H6}+(1.-R)*
 &NN2R)/((1.-R)/2.-R*(1.E06/PPMCO-1.)-1.)
 60 NCO2=NCH4+2.*NC2H6-NCO
 NO2P=(2.*NO2R-2.*NCH4-3.*NC2H6-NCO-2.*NCO2)/2.
 NH2OPV=(1.E06-PPMCO)*((1.-R)/2.*{2.*NO2R-2.*NCH4-3.
 &NC2H6}+(1.-R)*NN2R)/((1.-R)/2.*PPMCO-R*(1.E06-PPMCO)
 &-PPMCO)-NN2P-NO2P-NCO2
 90 NH2OPL=2.*NCH4+3.*NC2H6+NH2OR-NH2OPV
 SOOT=0

C.....
 IF(NO2P.GE.0)GOTO 500

C.....
 C.....IF NO2P IS LESS THAN ZERO, SET NO2P=0 AND CALCULATE
 C.....MOLES PRODUCTS AGAIN BUT INCLUDE MOLES CARBON (SOOT)
 C.....

U=PAMB/PSAT-1.
 NO2P=0.
 NCO2=- (PPMCO*(U+1.)*NN2R+(PPMCO-U*(1.E06-PPMCO))*(2.
 &*NO2R-2.*NCH4-3.*NC2H6))/(PPMCO*(U+1.)-2.*(PPMCO-U*
 &(1.E06-PPMCO)))
 NCO=2.*NO2R-2.*NCH4-3.*NC2H6-2.*NCO2
 SOOT=NCH4+2.*NC2H6-NCO2-NCO
 NH2OPV=(NCO2+NCO+NN2R)/U
 NH2OPL=2.*NCH4+3.*NC2H6+NH2OR-NH2OPV

C.....
 C.....CALCULATE DRE

C.....
 C.....PPB SF6 MEASURED IN GAS CHROMATOGRAPH =
 C.....2.34067E-04*SF6FIN-6.67068E-10*SF6FIN**2

C.....
 500 NSF6P=(2.34067E-04*SF6FIN-6.67068E-10*SF6FIN**2)
 &*1.E-09*(NCO2P+NCO+NO2P+NN2P+NH2OPV)

```

DRE=1.-NSF6P/SF6FLO
C.....
C.....CALCULATE DRE INCLUDING EFFECTS OF DILUTION AIR
C. ....
      XLEAK=6.06111E-03*(AIRFLO+FUELFL)+1362.68
      NSF6P=(2.34067E-04*SF6PIN-6.67066E-10*SF6PIN**2)
      &*1.E-09*(NCO2P+NCOP+NO2P+NN2P+NH2OPV+XLEAK)
      DRECOR=1.-NSF6P/SF6FLO
C.....
C.....CALCULATE AIR-FUEL RATIO, ACTUAL AND STOICHIOMETRIC,
C.....EXCESS AIR, THEORETICAL AIR, AND EQUIVALENCE RATIO
C.....
      AFACT=(NO2R*32.0+NN2R*28.008)/(NCH4*16.04+NC2H6*30.07)
      AFSTOI=((4.*NCH4+7.*NC2H6)/2.*(32.0+3.764*28.008))
      &/((NCH4*16.04+NC2H6*30.07)
      PHI=AFSTOI/AFACT
      TA=100./PHI
      EA=TA-100,
C.....
C.....CALCULATE PERCENT O2 USING G.C. DATA
      GCO2=O2FINL*3.5449E-05
C.....CALCULATE PERCENT O2 FROM MOLES PRODUCTS
      O2CALC=NO2P*100./(NO2P+NN2P+NH2OPV+NCO+NCO2)
C.....
C.....CALL ADIABATIC FLAME TEMPERATURE ROUTINE
C.....
777  NH2OP=NH2OPV+NH2OPL-NH2OR
      CALL TADIAB(NCH4,NC2H6,NO2R,NN2R,NH2OR,NCO2,NCO,NH2OP,
      &NO2P,NN2P,TAMB,TAMB,TEXH,TADI,QLOSS)
      RETURN
      END

```

APPENDIX C

SUBROUTINE TADIAB

```

C..... THIS PROGRAM CALCULATES THE ADIABATIC FLAME
C..... TEMPERATURE FOR A MIXTURE OF CH4 AND C2H6 AT ANY
C..... TEMPERATURE > 298K WITH AIR AT ANY TEMPERATURE
C..... > 220K. THE FOLLOWING VALUES ARE INPUT:
C.....
C..... NCH4      MOLES CH4
C..... NC2H6    .. C2H6
C..... NO2R     MOLES O2 IN REACTANTS
C..... NN2R     .. N2 ..
C..... NH2OR    .. H2O ..
C..... NCO2     MOLES CO2 IN PRODUCTS
C..... NCO      .. CO ..
C..... NH2OP    .. H2O ..
C..... NO2P     .. O2 ..
C..... NN2P     .. N2 ..
C..... TAIR     AIR TEMPERATURE
C..... TFUEL    FUEL TEMP
C..... TEXH     EXHAUST TEMP
C..... H(I,J)   A MATRIX CONTAINING VALUES OF ENTHALPY FOR THE
C..... ABOVE GASES AT VARIOUS TEMPERATURES: I=1,N2; 2,O2;
C..... 3,CO; 4,CO2; 5,H2O. THE VALUES ARE TAKEN FROM
C..... WARK (1983)
C..... J=155 STORES THE VALUE FOR T=298K
C..... J=156 STORES THE INTERPOLATED VALUE FOR T-REACTANTS
C..... J=157 STORES THE INTERPOLATED VALUE FOR T-PRODUCTS
C..... THE OUTPUT VALUES ARE:
C..... TADIAB- ADIABATIC FLAME TEMPERATURE FOR GIVEN
C..... CONDITIONS
C..... QLOSS- ACTUAL HEAT LOSS TO COMBUSTION CHAMBER
C.....
SUBROUTINE TADIAB(NCH4,NC2H6,NO2R,NN2R,NH2OR,NCO2,NCO,
&NH2OF,NO2P,NN2P, TAIR,TFUEL,TEXH,TAD1,QLOSS)
DIMENSION H(5,157)
REAL NCH4,NC2H6,NN2R,NO2R,NN2P,NO2P,NCO,NCO2,NH2OP,
&NH2OR
HFCO2=-393520
HFH2O=-241820
HFCH4=-74850
HFC2H6=-84680
HFCO=-110530
OPEN(1,FILE="HDATA")
READ(1,50)((h(I,J),J=1,157),I=1,5)
50 FORMAT(1X,5F13.2)
CLOSE(1)
CALL INTERP(TAIR,J,FRACT)
DO 100 I=1,2
100 H(1,156)=FRACT*(H(I,J+1)-H(I,J))+H(I,J)
H(5,156)=FRACT*(H(5,J+1)-H(5,J))+H(5,J)
C.....DHCH4 IS TAKEN FROM WARK (1983)

```

```

DHC4=8.314*(3.826*TFUEL-1.9895E-03*TFUEL**2+8.186E-06
&*TFUEL**3-5.6832E-09*TFUEL**4+1.3926E-12*TFUEL**5-
&1138.55)
C.....DHC2H6 IS TAKEN FROM OBERT (1973)
DHC2H6=16.7879*TFUEL+0.0616423*TFUEL**2-10476.88
SUM=-NCH4*(HFC4+DHC4)-NC2H6*(HFC2H6+DHC2H6)-NN2R*
&(H(1,156)-H(1,155))-NO2R*(H(2,156)-H(2,155))-NN2P*
&H(1,155)-NO2P*H(2,155)+NCO*(HFCO-H(3,155))+MCO2*(HFCO2
&-H(4,155))+NH2OP*(HFH2O-H(5,155))-NH2OR*(HFH2O+
&H(5,156)-H(5,155))
C..... ASSUME ALL PRODUCTS ARE N2 FOR INITIAL ESTIMATE
HASSUM=-SUM/(NN2P+NO2P+NCO+NCO2+NH2OP)
DO 150 N=1,154
I=N+1
IF(H(1,N).GE.HASSUM)GOTO 200
150 CONTINUE
C..... ITERATE AT LOWER AND LOWER TEMPERATURES UNTIL A
C..... NEGATIVE VALUE OF RL IS REACHED. INTERPOLATE BETWEEN
C..... THE POSITIVE (RH) AND NEGATIVE (RL)
C..... VALUES FOR THE CORRECT TEMPERATURE AT A VALUE OF ZERO.
200 RL=NCO2*H(4,I)+NCO*H(5,I)+NH2OP*H(5,I)+NO2P*H(2,I)+
&NN2P*H(1,I)+SUM
IF(RL.LE.0)GOTO 225
RH=RL
I=I-1
IF(I.LE.0) STOP 200
GOTO 200
C..... FIND TEMP CORRESPONDING TO I,I+1 (TLOW,THIGH)
225 IF(I.GE.79)GOTO 250
TLOW=10*I+210
THIGH=10*(I+1)+210
GOTO 350
250 IF(I.GE.129)GOTO 300
TLOW=20*I-580
THIGH=20*(I+1)-580
GOTO 350
300 IF(I.GT.154)STOP 300
TLOW=50*I-4450
THIGH=50*(I+1)-4450
C..... INTERPOLATE TO GET TADIAB
350 TADI=-RL/(RH-RL)*(THIGH-TLOW)+TLOW
C.....
C.....
C.....
C.....
CALL INTERP(TEX,H,J,FRACT)
DO 400 I=1,5
400 H(1,157)=FRACT*(H(I,J+1)-H(I,J))+H(I,J)
QLOSS=NN2P*H(1,157)+NO2P*H(2,157)+NCO*H(3,157)+NCO2
&*H(4,157)+NH2OP*H(5,157)+SUM
RETURN
END
C.....
C.....

```

```

C.....
C..... T (TEMP) IS INPUT, J AND FRACT ARE OUTPUT FOR
C..... INTERPOLATION
          SUBROUTINE INTERP(T,J,FRACT)
          IF(T.GE.1000)GOTO 100
          X=(T-210)/10
          GOTO 200
100      IF(T.GE.2000)GOTO 150
          X=(T+580)/20
          GOTO 200
150      IF(T.GT.3250)STOP 150
          X=(T+4450)/50
200      J=X
          FRACT=X-J
C..... INTERPOLATED VALUE OF H HAS THE FOLLOWING FORM:
C.....  $H(I,156) \ominus FRACT * (H(I,J+1) - H(I,J)) + H(I,J)$ 
          RETURN
          END

```

APPENDIX D

PROGRAMS USED FOR PHASE 2

```

C.....THIS PROGRAM WAS USED TO ANALYZE THE SF6 DATA FROM
C.....THE SECOND PHASE. IT INCORPORATES THE SIMPLIFYING
C.....ASSUMPTIONS DESCRIBED IN SECTION V.
C.....
C.....
C.....D(AIR,FUEL,K)
C.....D CONTAINS ALL INPUT AND CALCULATED DATA.
C.....NEWDAT CONTAINS INPUT DATA ONLY AND IS OF
C.....THE SAME FORM AS D.
C.....THE VARIABLES IN D ARE NAMED IN SUBROUTINE STOICH.
C.....
C.....AIR=5*I+50
C.....FUEL=-2J+22
C.....
C.....
C.....      DIMENSION D(5,5,41)
C.....      OPEN (1,FILE="NEWDAT")
C.....      READ (1,*)((D(I,J,K),K=1,13),J=1,5),I=1,5)
C.....      CLOSE (1)
C.....
C.....      DO 10 I=1,5
C.....      DO 5 J=1,5
C.....
C.....      CALL STCICH(D(I,J,2),D(I,J,1),D(I,J,9),D(I,J,11),
C.....      &D(I,J,10),D(I,J,8),D(I,J,4),D(I,J,13),
C.....      &D(I,J,6),D(I,J,7),D(I,J,14),D(I,J,15),D(I,J,16),
C.....      &D(I,J,20),D(I,J,19),D(I,J,21),D(I,J,23),D(I,J,24),
C.....      &D(I,J,22),D(I,J,29),D(I,J,26),D(I,J,27),D(I,J,28),
C.....      &D(I,J,30),D(I,J,33),D(I,J,34),D(I,J,35),D(I,J,17),
C.....      &D(I,J,18),D(I,J,31),D(I,J,32),D(I,J,36),D(I,J,37),
C.....      &D(I,J,38),D(I,J,39),D(I,J,40),D(I,J,41))
C.....
5      CONTINUE
10     CONTINUE
C.....
C.....WRITE RESULTS TO FILE
C.....
C.....      OPEN(2,FILE="ANALYZEDDATA")
C.....      WRITE(2,*)((D(I,J,K),K=1,41),J=1,5),I=1,5)
20     FORMAT(E12.6)
C.....      CLOSE(2)
C.....      STOP
C.....      END
C.....
C.....
C.....
C.....THIS SUBROUTINE DETERMINES THE STOICHIOMETRIC EQUATION,
C.....DRE, EXCESS AIR, AF RATIO, EQUIVALENC RATIO, THEORETICAL
C.....AIR
C.....

```

C.....VARIABLES:

C..... GASROT = FUEL ROTAMETER VALUE
 C..... AIRROT = AIR ROTAMETER VALUE
 C..... TAMB = AMBIENT TEMPERATURE
 C..... TEXH = EXHAUST TEMPERATURE
 C..... TSMPL = SAMPLE TEMPERATURE
 C..... SF6FIN = SF6 PEAK AREA MEASUREMENT
 C..... SF6FLO = SF6 FLOW RATE
 C..... O2FINL = OXYGEN PEAK AREA MEASUREMENT
 C..... PAMB = AMBIENT PRESSURE
 C..... PSAT = SATURATION PRESSURE OF WATER AT TSMPL
 C..... NCH4 = MOLES CH4, ETC.
 C..... TA = THEORETICAL AIR
 C..... AFACT = ACTUAL AIR FUEL RATIO
 C..... AFSTOI = STOICHIOMETRIC AIR FUEL RATIO
 C..... PHI = EQUIVALENCE RATIO
 C..... EA = EXCESS AIR
 C..... TADI = ADIABATIC FLAME TEMPERATURE
 C..... DRE = DRE OF SF6
 C..... GCO2 = PERCENT O2 FROM GC AREA MEASUREMENTS
 C..... O2CALC = CALCULATED PERCENT OXYGEN FROM INPUT DATA
 C..... FUELFL = FUEL FLOW
 C..... K = RATE CONSTANT
 C..... T = CHARACTERISTIC TIME VALUE

C.....
 C..... SUBROUTINE STOICH (GASROT,AIRROT,TAMB,TEXH,TSMPL,SF6FIN,
 &SF6FLO,O2FINL,PAMB,PSAT,NCH4,NC2H6,NO2R,NCO,NCO2,NO2P,
 &NH2OPV,NH2OPL,NN2P,TA,AFACT,AFSTOI,PHI,EA,TADI,QLOSS,
 &DRE,NN2R,NH2OR,GCO2,O2CALC,FUELFL,K,T,LG,DR,KT)

C.....
 C..... REAL NCH4,NC2H6,NO2R,NN2R,NCO,NCO2,NO2P,NH2OR,
 &NH2OPV,NH2OPL,NN2P,NH2OP,NSF6P,K,LG,KT

C.....
 C..... EQN TO CALCULATE FUEL FLOW (ML/S)
 FUELFL=42.75+2.50438*GASROT+0.354184*GASROT**2

C.....
 C..... EQN TO CALC AIR FLOW (ML/S)
 AIRFLO=38.13*AIRROT

C.....
 C.....
 C..... EQNS TO SOLVE THE CHEMICAL REACTION EQN AND SF6 CONCENTRATION
 C..... ASSUME: ALL H GOES TO H2O, ALL C GOES TO CO. DRY INLET AIR,
 C..... SO NCO=0 AND NH2OR=0.

C.....
 SF6CON=SF6FLO/((FUELFL+AIRFLO)*1.E09
 NCH4=.976*FUELFL
 NC2H6=.024*FUELFL
 NO2R=.2099*AIRFLO
 NN2R=.7901*AIRFLO
 NN2P=NN2R

C.....
 C..... ASSUME NO CONDENSATION OF WATER VAPOR
 C.....

```

NH2OPV=2.*NCH4+3.*NC2H6
NCO2=NCH4+2.*NC2H6
NO2P=(2.*NO2R-2.*NCO2-2.*NCH4-3.*NC2H6)/2.
PH2O=NH2OPV*PAMB/(NH2OPV+NN2P+NO2P+NCO2)
NH2OPL=0.
IF(PH2O.LE.PSAT)GOTO 500

C.....
C.....
C.....PPB SF6 MEASURED IN GAS CHROMATOGRAPH=
C.....2.1801E-02 + 2.7263E-04*SF6FIN - 9.1195E-11*SF6FIN**2
C.....
500 NSF6P=(2.1801E-02+2.7263E-04*SF6FIN-9.1195E-11*
& SF6FIN**2)*1.E-09*(NCO2P+NCOP+NO2P+NN2P+NH2OPV)
C.....
DRE=1.-NSF6P/SF6FLO
C.....
C.....
C.....CALCULATE AIR-FUEL RATIO, ACTUAL AND STOICHIOMETRIC,
C.....EXCESS AIR, THEORETICAL AIR, AND EQUIVALENCE RATIO.
C.....
AFACT=(NO2R*32.0+NN2R*28.008)/(NCH4*16.04+NC2H6*30.07)
AFSTOI=((4.*NCH4+7.*NC2H6)/2.*(32.0+3.764*28.008))
&/(NCH4*16.04+NC2H6*30.07)
PHI=AFSTOI/AFACT
TA=100.,PHI
EA=TA-100.

C.....
C.....
C.....
C.....CALL ADIABATIC FLAME TEMPERATURE SUBROUTINE
C.....(SEE APPENDIX 4 FOR THIS SUBROUTINE,
C.....
C.....
CALL TAD13(NCH4,NC2H6,NO2R,NN2R,NH2OR,NCO2,NCO,NH2OP,
&NO2P,NN2P,PAMB,TAMB,TEXH,TADI,QLCSS)

C.....
C.....
C.....CALCULATE CHARACTERISTIC TIME VALUE AND RATE CONSTANT
C.....AS DEVELOPED IN SECTION V
C.....
T=1/(FUELFL*TADI)
DR=(1.-DRE)
LG=-ALOG(DR)
K=LG/T
KT=T*309439.*EXP(0.301258*TADI)
RETURN
END

```

```

C.....THIS PROGRAM WAS USED TO ANALYZE THE WASTE DATA
C.....
C.....
C.....D(AIR,FUEL,K)
C.....D CONTAINS ALL INPUT AND CALCULATED DATA.
C.....THE VARIABLES IN D ARE NAMED IN SUBROUTINE STOICH.
C.....
C.....AIR=60+20(I-1)
C.....FUEL=12+4(J-1)
C.....
C.....
          DIMENSION D(5,5,20)
          READ (*,*)((D(I,J,K),K=1,4),J=1,5),I=1,5)
C.....
          DO 10 I=1,5
          DO 5 J=1,5
C.....
          D(I,J,5) = 757.0
          D(I,J,6) = 298.0
          CALL STOICH(D(I,J,1),D(I,J,2),D(I,J,3),D(I,J,4),
&D(I,J,5),D(I,J,6),D(I,J,7),D(I,J,8),D(I,J,9),D(I,J,10),
&D(I,J,11),D(I,J,12),D(I,J,13),D(I,J,14),D(I,J,15),
&D(I,J,16),D(I,J,17),
&D(I,J,18),D(I,J,19),D(I,J,20))
          5 CONTINUE
          10 CONTINUE
C.....
C.....WRITE RESULTS TO FILE
C.....
          WRITE(*,*)((D(I,J,K),K=1,20),J=1,5),I=1,5)
          STOP
          END
C.....
C.....
C.....
C.....
C.....THIS SUBROUTINE DETERMINES THE STOICHIOMETRIC EQUATION,
C.....DRE, AND MIXING RATE (USING SF6 DATA)
C.....
C.....      NCH4   = MOLES CH4, ETC.
C.....      TADI   = ADIABATIC FLAME TEMPERATURE
C.....      DRE    = DRE OF SF6
C.....      FUELFL  = FUEL FLOW
C.....      K      = RATE CONSTANT
C.....      T      = CHARACTERISTIC TIME VALUE
C.....      AIN    = INLET WASTE AREA MEASUREMENT
C.....      AOUT   = EXHAUST WASTE AREA MEASUREMENT
C.....
C.....
C.....
          SUBROUTINE STOICH AIRROT,FUELFL,AIN,AINC,PAMB,TAMB,
&NCH4,NC2H6,NO2R,NCO2,NC2F,NN2P,
&NH2OP,TADI,DRE,K,T,LG,FT)
C.....

```

```

REAL NCH4,NC2H6,NO2R,NN2R,NCO2,NO2P,
&NH2OP,NN2P,NPT,K,LG,KT
C.....
C.....
C.....EQN TO CALC AIR FLOW (ML/S)
AIRFLO=38.13*AIRROT
C.....
C.....
C.....EQNS TO SOLVE THE CHEMICAL REACTION EQN
C.....ASSUME: ALL H GOES TO H2O, ALL C GOES TO CO2, DRY INLET AIR
C.....
NCH4=.976*FUELFL
NC2H6=.024*FUELFL
NO2R=.2099*AIRFLO
NN2R=.7901*AIRFLO
NN2P=NN2R
C.....
C.....ASSUME NO CONDENSATION OF WATER VAPOR
C.....
NH2OP=2.*NCH4+3.*NC2H6
NCO2=NCH4+2.*NC2H6
NO2P=(2.*NO2R-2.*NCO2-2.*NCH4-3.*NC2H6)/2.
NPT=NH2OP+NCO2+NO2P
C.....
C.....
C.....CALL ADIABATIC FLAME TEMPERATURE SUBROUTINE
C.....
CALL TADIAB(NCH4,NC2H6,NO2R,NN2R,NCO2,NH2OP,
&NO2P,NN2P,TAMB,TAMB,TADI)
C.....
C.....
C.....CALCULATE CHARACTERISTIC TIME VALUE, RATE CONSTANT
C.....AND DRE
C.....
DRE=1-(AOUT*NPT)/(AIN*(FUELFL+AIRFLO))
T=1/(FUELFL*TADI)
DR=(1.-DRE)
LG=-ALOG(DR)
K=LG/T
KT=T*300000.*EXP(TADI/782)
RETURN
END

```

APPENDIX E

SAMPLE DATA

The following pages contain a sample of the measured data and many of the calculated values from Phase 1 of the experiment. Phase 2 values are very similar and are not included here. The section labeled "Measured Data" contains the data obtained directly from the experiment. The section labeled "Equation of Reaction" contains the reaction equation where the reactants are given in mL/s. $H_2O(v)$ and $H_2O(l)$ represent water in the vapor and liquid states, respectively.

The "Calculated Data" section includes the percent oxygen as measured by the gas chromatograph. These values have been used to verify the oxygen measurements obtained from the CO/O_2 analyzer. The calculated percent oxygen value does not include the effect of the dilution air and, therefore, does not match that of the CO/O_2 analyzer or GC. The SF_6 DRE value includes the effects of the dilution air.

Finally, the "Temperature Data" section includes the temperature measurements for all 21 locations shown in Figure 7. A zero value of temperature indicates that the temperature was over the range of the temperature probe (1170 K). These temperature measurements were taken on different days. To verify consistency in the temperature data, the temperature at Location 21 was repeated when the actual DRE data was being collected. This repeat measurement is shown in the "Measured Data" section.

SAMPLE DATA

Measured Data

Air Rotameter	100.0	Ambient Temp (K)	297.
Fuel Rotameter	20.0	Ambient Press (mmHg)	762.5
CO (ppm)	9.	Wet Bulb Temp (K)	284.3
O ₂ (% by analyzer)	12.6	Dry Bulb Temp (K)	296.5
SF ₆ Flow (ml/s)	0 020588	SF ₆ Peak Area	49003.
Temp(21) (K)	699.	O ₂ Peak Area	331005.

Equation of Reaction (Reactants in mL/s)

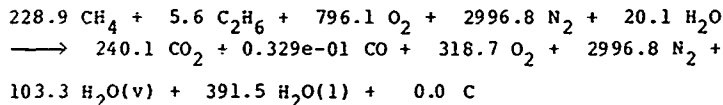

Calculated Data

Air/Fuel Ratio	= 28.5 +/- 0.5
Equivalence Ratio	= 0.600 +/- 0.000
Excess Air (%)	= 66.7 +/- 4.1
C ₂ (% From GC Area)	= 11.73
C ₂ (% Calculated)	= 8.71 +/- 0.31
Adiabatic Flame Temp (K)	= 1636. +/- 27.
SF ₆ DRE	= 0.997696 +/- 0.000659

Temperature Data (K)

Temp(1) = 630.	Temp(8) = 918.	Temp(15) = 660.
Temp(2) = 660.	Temp(9) = 969.	Temp(16) = 655.
Temp(3) = 690.	Temp(10) = 939.	Temp(17) = 588.
Temp(4) = 737.	Temp(11) = 514.	Temp(18) = 525.
Temp(5) = 754.	Temp(12) = 516.	Temp(19) = 545.
Temp(6) = 858.	Temp(13) = 540.	Temp(20) = 469.
Temp(7) = 900.	Temp(14) = 574.	Temp(21) = 686.

SAMPLE DATA

Measured Data

Air Rotameter	60.0	Ambient Temp (K)	297.
Fuel Rotameter	20.0	Ambient Press (mmHg)	162.5
CO (ppm)	15.	Wet Bulb Temp (K)	284.3
O ₂ (% by analyzer)	7.2	Dry Bulb Temp (K)	296.5
SF ₆ Flow (ml/s)	0.020588	SF ₆ Peak Area	5965.
Temp(21) (K)	644.	O ₂ Peak Area	191688.

Equation of Reaction (Reactants in mL/s)

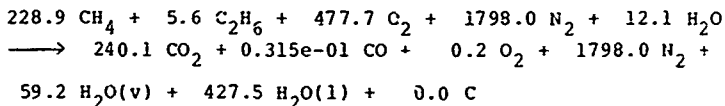

Calculated Data

Air/Fuel Ratio	=	17.1 +/-	0.4
Equivalence Ratio	=	1.000 +/-	0.001
Excess Air (%)	=	0.0 +/-	3.6
O ₂ (% From GC Area)	=	6.80	
O ₂ (% Calculated)	=	0.01 +/-	0.43
Adiabatic Flame Temp (K)	=	2299. +/-	26.
SF ₆ DRE	=	0.999784 +/-	0.000068

Temperature Data (K)

Temp(1) =	600.	Temp(8) =	1034.	Temp(15) =	819.
Temp(2) =	620.	Temp(9) =	1099.	Temp(16) =	323.
Temp(3) =	649.	Temp(10) =	0.	Temp(17) =	589.
Temp(4) =	685.	Temp(11) =	538.	Temp(18) =	642.
Temp(5) =	751.	Temp(12) =	595.	Temp(19) =	630.
Temp(6) =	766.	Temp(13) =	627.	Temp(20) =	470.
Temp(7) =	941.	Temp(14) =	695.	Temp(21) =	648.

SAMPLE DATA

Measured Data

Air Rotameter	100.0	Ambient Temp (K)	297.
Fuel Rotameter	10.0	Ambient Press (mmHg)	762.5
CO (ppm)	3.	Wet Bulb Temp (K)	284.3
O ₂ (% by analyzer)	17.1	Dry Bulb Temp (K)	296.5
SF ₆ Flow (ml/s)	0.020588	SF ₆ Peak Area	150.
Temp(21) (K)	546.	O ₂ Peak Area	493123.

Equation of Reaction (Reactants in mL/s)

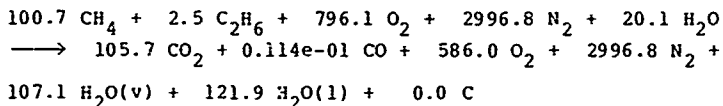

Calculated Data

Air/Fuel Ratio	=	64.7 +/-	3.1
Equivalence Ratio	=	0.264 +/-	0.000
Excess Air (%)	=	278.9 +/-	10.3
O ₂ (% From GC Area)	=	17.48	
O ₂ (% Calculated)	=	15.44 +/-	0.17
Adiabatic Flame Temp (K)	=	945. +/-	18.
SF ₆ DRE	=	0.999991 +/-	0.000003

Temperature Data (K)

Temp(1) = 536.	Temp(8) = 715.	Temp(15) = 520.
Temp(2) = 543.	Temp(9) = 744.	Temp(16) = 513.
Temp(3) = 560.	Temp(10) = 751.	Temp(17) = 461.
Temp(4) = 576.	Temp(11) = 408.	Temp(18) = 426.
Temp(5) = 608.	Temp(12) = 431.	Temp(19) = 421.
Temp(6) = 653.	Temp(13) = 433.	Temp(20) = 370.
Temp(7) = 691.	Temp(14) = 467.	Temp(21) = 558.

SAMPLE DATA

Measured Data

Air Rotameter	60.0	Ambient Temp (K)	297.
Fuel Rotameter	10.0	Ambient Press (mmHg)	762.5
CO (ppm)	1.	Wet Bulb Temp (K)	284.3
O ₂ (% by analyzer)	15.3	Dry Bulb Temp (K)	296.5
SF ₆ Flow (ml/s)	0.020588	SF ₆ Peak Area	83.
Temp(21) (K)	534.	O ₂ Peak Area	416329.

Equation of Reaction (Reactants in mL/s)

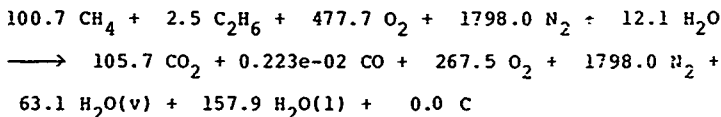

Calculated Data

Air/Fuel Ratio	=	38.8 +/-	2.2
Equivalence Ratio	=	0.440 +/-	0.000
Excess Air (%)	=	127.3 +/-	8.7
O ₂ (% From GC Area)	=	14.76	
O ₂ (% Calculated)	=	11.97 +/-	0.35
Adiabatic Flame Temp (K)	=	1327. +/-	35.
SF ₆ DRE	=	0.999997 +/-	0.000001

Temperature Data (K)

Temp(1) = 509.	Temp(8) = 749.	Temp(15) = 598.
Temp(2) = 521.	Temp(9) = 824.	Temp(16) = 623.
Temp(3) = 538.	Temp(10) = 854.	Temp(17) = 523.
Temp(4) = 555.	Temp(11) = 430.	Temp(18) = 478.
Temp(5) = 590.	Temp(12) = 467.	Temp(19) = 493.
Temp(6) = 611.	Temp(13) = 471.	Temp(20) = 406.
Temp(7) = 706.	Temp(14) = 511.	Temp(21) = 539.

REFERENCES

1. National Bureau of Standards, Investigation of Air Force Industrial Process Incineration Final Technical Report, ESL-TR-83-14, Engineering and Services Laboratory, Air Force Engineering and Services Center, Tyndall AFB Florida, August 1983.
2. Kimball, V.S., Waste Oil Recovery and Disposal, pp. 144-189, Noyes Data Corporation, Park Ridge, New Jersey, 1975.
3. Kiang, Y.H. and Metry, A.A., Hazardous Waste Processing Technology, Ann Arbor Science, Ann Arbor, Michigan, 1982.
4. Branscome, M., Westbrook, W., Mournighar, R., Bolstad, J., and Chehaske, J., "Summary of Testing at Cement Kilns Cofiring Hazardous Waste," paper presented at EPA Eleventh Annual Research Symposium on Incineration and Treatment of Hazardous Waste, Cincinnati, Ohio, April 29-May 1, 1985.
5. Fennelly, P.F., McCabe, M., and Hall, J., "Environmental Characterization of the Combustion of Waste Oil in Small Commercial Boilers," paper presented at EPA Tenth Annual Research Symposium on Incineration and Treatment of Hazardous Waste, Ft. Mitchell, Kentucky, April 3-5, 1984.
6. Karasek, F.W., Viau, A.C., Guiochon, G., and Gonnord, M.F., "Gas Chromatographic-Mass Spectrometric Study on the Formation of Polychlorinated Dibenzo-P-Dioxins and Polychlorobenzenes from Polyvinyl Chloride in a Municipal Incinerator," Journal of Chromatography, vol 270, pp. 227-234, 1983.
7. Shaub, W.M. and Tsang, W., "Dioxin Formation in Incinerators," Environmental Science and Technology, vol 17, pp. 721-730, December 1983.
8. Bonner, T., Desai, B., Fullenkamp, J., Hughes, T., Kennedy, Z., McCormick, R., Peters, J., and Zanders, D., Engineering Handbook for Hazardous Waste Incineration, Draft U.S. EPA 68-03-2550, U.S. Environmental Protection Agency, Office of Research and Development, Washington, DC, November 1980.
9. Hall, F.D., Kemner, W.F., and Staley, L.J., "Evaluation of Feasibility of Incinerating Hazardous Wastes in High-Temperature Industrial Processes," paper presented at EPA Eighth Annual Research Symposium on Incineration and Treatment of Hazardous Waste, Ft. Mitchell, Kentucky, March 8-10, 1982.

10. Huffman, G.L., Wolbach, C.D., and Waterland, L.R., "Overview of the Concept of Disposing of Hazardous Waste in Industrial Boilers," paper presented at EPA Solid and Hazardous Waste Research Division's Eighth Annual Research Symposium on the Treatment of Hazardous Waste, Ft. Mitchell, Kentucky, March 9, 1982.
11. Chigier, N., Energy, Combustion and Environment, pp. 347-348, McGraw-Hill, New York, 1981.
12. Lewis, B. and von Elbe, G., Combustion, Flames and Explosions of Gases, 2nd ed., Academic Press, New York, 1961.
13. Sorensen, H.A., Energy Conversion Systems, John Wiley & Sons, New York, 1983.
14. Kramlich, J.C., Poncelet, E.M., Seeker, W.R., and Samuelson, G.S., "A Laboratory Study on the Effect of Atomization on Destruction and Removal Efficiency for Liquid Hazardous Wastes," paper presented at EPA Eleventh Annual Research Symposium on Incineration and Treatment of Hazardous Waste, Cincinnati, Ohio, April 29-May 1, 1985.
15. La Fond, R.K., Kramlich, R.C., Seeker, W.R., and Samuelson, G.S., "Evaluation of Continuous Performance Monitoring Techniques for Hazardous Waste Incinerators," Journal of the Air Pollution Control Association, vol 35, pp. 658-665, 1985.
16. Fernandez-Pello, A.C. and Trezek, G.J., "Destruction of Toxic Waste by Vortex Combustion," Hazardous Waste Engineering Research Laboratory, U.S. EPA, Cincinnati, Ohio, 1985.
17. Santoleri, J.J., "Chlorinated Hydrocarbon Waste Disposal and Recovery Systems," Chemical Engineering Progress, vol 69, pp. 68-74, January 1973.
18. Olexsey, R.A., "Incineration of Hazardous Waste in Power Boilers: Emissions Performance Study Rationale and Test Site Matrix," paper presented at EPA Tenth Annual Research Symposium on Incineration and Treatment of Hazardous Waste, Ft. Mitchell, Kentucky, April 3-5, 1984.
19. Kiang, Y.H., "Controlling Vinyl Chloride Emissions," Chemical Engineering Progress, vol 72, p. 37, 1976.
20. Kiang, Y.H., "Liquid Waste Disposal Systems," Chemical Engineering Progress, vol 72, p. 71, 1976.
21. Bott, J.F. and Jacobs, T.A., "Shock-Tube Studies of Sulfur Hexafluoride," Journal of Chemical Physics, vol 50, pp. 3850-3855, May 1969.

22. Lyman, J.L., "A Model for Unimolecular Reaction of Sulfur Hexafluoride," Journal of Chemical Physics, vol 67, pp. 1868-1876, September 1977.
23. Tsang, W. and Shaub, W.M., "Surrogates as Substitutes for Principal Organic Hazardous Constituent Validation of Incinerator Operation," paper presented at Second Conference on Municipal, Hazardous and Coal Wastes Management, University of Miami, Coral Gables, Florida, December 5-7, 1983.
24. Carnes, R.A., "Operations at the USEPA Combustion Research Facility," paper presented at EPA Tenth Annual Research Symposium on Incineration and Treatment of Hazardous Waste, Ft. Mitchell, Kentucky, April 3-5, 1984.
25. Trenholm, A., Hathaway, R., and Oberacker, D., "Products of Incomplete Combustion from Hazardous Waste Incinerators," paper presented at EPA Tenth Annual Research Symposium on Incineration and Treatment of Hazardous Waste, Ft. Mitchell, Kentucky, April 3-5, 1984.
26. Whitmore, F.C., Carnes, R.A., and Rubey, W.A., "A Suggested Laboratory Approach to Simplification of the POHC-PIC Dilemma," paper presented at EPA Eighth Annual Research Symposium on Incineration and Treatment of Hazardous Waste, Ft. Mitchell, Kentucky, March 8-10, 1982.
27. Chang, D., and Sorbo, N.W., "Evaluation of a Pilot Scale Circulating Bed Combustor with a Surrogate Hazardous Waste Mixture," paper presented at EPA Eleventh Annual Research Symposium on Incineration and Treatment of Hazardous Waste, Cincinnati, Ohio, April 29-May 1, 1985.
28. Mournighan, R.E., "Surrogate Compounds as Indicators of Hazardous Waste Incinerator Performance," paper presented at EPA Eleventh Annual Research Symposium on Incineration and Treatment of Hazardous Waste, Cincinnati, Ohio, April 29-May 1, 1985.
29. Wyss, A.W., Castaldini, C., and Mournighan, R.E., "Emission Testing of Process Kilns Cofired with Hazardous Waste," paper presented at EPA Eleventh Annual Research Symposium on Incineration and Treatment of Hazardous Waste, Cincinnati, Ohio, April 29-May 1, 1985.
30. Simmonds, P.G., Lovelock, A.J., and Lovelock, J.E., "Continuous and Ultrasensitive Apparatus for the Measurement of Air-Borne Tracer Substances," Journal of Chromatography, vol 126, pp. 3-9, 1976.
31. Simmonds, P.G., Shoemaker, G.R., and Lovelock, J.E., "Improvements in the Determination of Sulfur Hexafluoride for Use as a Meteorological Tracer." Analytical Chemistry, vol 44, pp. 860-863, April 1972.

32. Dietz, R.N. and Cote, E.A., "Tracing Atmospheric Pollutants by Gas Chromatographic Determination of Sulfur Hexafluoride," Environmental Science and Technology, vol 7, pp. 338-342, April 1973.
33. Heggen, R. and Oehme, M., "Columns for Simultaneous Gas Chromatographic Determination of PPT Levels of the Atmospheric Tracers Sulphur Hexafluoride and Bromotri-fluoromethane in Ambient Air Samples," Journal of Chromatography, vol 243, pp. 168-172, 1982.
34. Lamb, B.K., Vitols, V., and Skogvold, O., "Atmospheric Tracer Techniques and Gas Transport in the Primary Aluminum Industry," Journal of the Air Pollution Control Association, vol 30, p. 558, May 1980.
35. Morrison, C.A., Wiggins, D.B., and Ingley, H.A., Mobile Home Air Conditioning and Energy Consumption Test; Zone 1, Final Report, University of Florida College of Engineering Solar Energy Laboratory, April 1980.
36. Ahmad, T. and Plee, S.L., "Using a Tracer-Gas Technique to Study Combustion and Mixing in a Diesel Engine," paper presented at The Combustion Institute, Central States Section, Minneapolis, Minnesota, March 19-20, 1984.
37. Adams, R.C., Hartman, M.W., and Wagoner, D.E., "Field Tests of Industrial Boilers and Industrial Processes Disposing of Hazardous Wastes," paper presented at EPA Tenth Annual Research Symposium on Incineration and Treatment of Hazardous Waste, Ft. Mitchell, Kentucky, April 3-5, 1984.
38. Peters, J.A. and Mournighan, J.E., "Effects of Disposal of Hazardous Wastes in Cement Kilns on Conventional Pollutant Emissions," paper presented at EPA Tenth Annual Research Symposium on Incineration and Treatment of Hazardous Waste, Ft. Mitchell, Kentucky, April 3-5, 1984.
39. Seeker, W.R., Kramlich, J.R., Heap, M.P., Nihart, R.K., and Samuelson, G.R., "Flame-Mode Hazardous Waste Destruction Research," paper presented at EPA Tenth Annual Research Symposium on Incineration and Treatment of Hazardous Waste, Ft. Mitchell, Kentucky, April 3-5, 1984.
40. Waterland, L.R., "Pilot-Scale Investigation of Surrogate Means of Determining POHC Destruction," paper presented at the 77th Annual Meeting of the Air Pollution Control Association, June 1984.
41. DeRosier, R.J., Mason, E.S., Spannagel, U., and Wolbach, C.D., "Nonsteady Industrial Boiler Waste Cooling Tests," paper presented at EPA Eleventh Annual Research Symposium on Incineration and Treatment of Hazardous Waste, Cincinnati, Ohio, April 29-May 1, 1985.

42. Wark, K., Thermodynamics, 4th ed., McGraw-Hill, New York, 1983.
43. Obert, E.F., Internal Combustion Engines and Air Pollution, Harper & Row, New York, 1973.
44. Kaplan, G.H., "An Analysis of Interim Storage of Low Level Radiation Waste and Incineration of Liquid Scintillation Counting Waste," Master's Thesis, University of Florida, 1982.
45. Salas, P., "Incineration: An Alternative for Disposal of Liquid Scintillation Counting Waste," Master's Thesis, University of Florida, 1982.