

AD-A181 491

ORDERED POLYMER NONLINEAR OPTICAL MATERIALS(U)
FOSTER-MILLER INC WALTHAM MA P J MARINACCIO ET AL.
APR 87 AFB-0104-FN-8660-79 AFOSR-TR-87-0628

1/1

UNCLASSIFIED

F49620-86-C-0104

F/G 20/6

NL

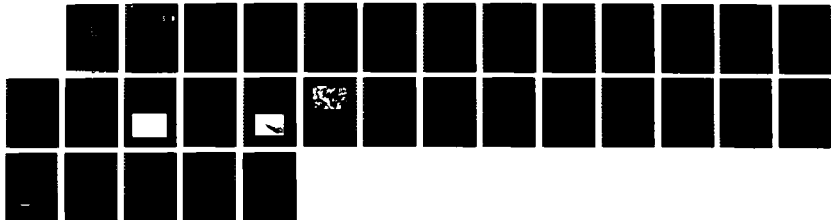

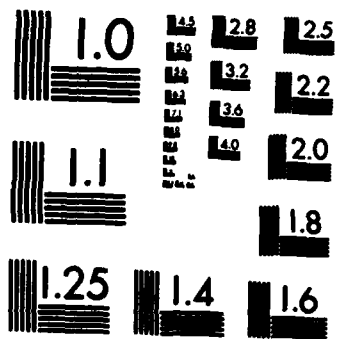

MICROCOPY RESOLUTION TEST CHART
NATIONAL BUREAU OF STANDARDS-1963-A

DTIC FILE COPY

②

Report AFB-0104-FM-8660-79

AD-A181 491

ORDERED POLYMER NONLINEAR OPTICAL MATERIALS

DTIC ELECTE
S D
JUN 12 1987
CSD

AFOSR-TR- 87 - 0 6 2 8

Paul J. Marinaccio
Mark A. Druy
Foster-Miller, Inc.
350 Second Avenue
Waltham, MA 02254

AIR FORCE OFFICE OF SCIENTIFIC RESEARCH (AFSC)
NOTICE OF TRANSMITTAL TO DTIC
This technical report has been reviewed and is
approved for public release IAW AFR 190-12.
Distribution is unlimited.
MATTHEW J. KERPER
Chief, Technical Information Division

April 1987

Final Report
September 1, 1986 to February 28, 1987
Contract No. F49620-86-C-0104

Distribution Statement

Prepared for

Directorate of AFOSR
Building 410
Bolling AFB, Washington DC 20332-6448

Approved for public release,
distribution unlimited

87 5 20 0 0 4

Research sponsored by the Air Force Office of Scientific Research (AFSC), under Contract F49620-86-C-0104. The United States Government is authorized to reproduce and distribute reprints for governmental purposes notwithstanding any copyright notation hereon.

This manuscript is submitted for publication with the understanding that the United States Government is authorized to reproduce and distribute reprints for governmental purposes.

LICENSE RIGHTS LEGEND

Contract No. F49620-86-C-0104

Contractor or subcontractor: Foster-Miller, Inc.

For a period of two (2) years after the delivery and acceptance of the last deliverable item under this contract, this technical data shall not, without the written permission of the above Contractor, be either (A) used, released or disclosed in whole or in part outside the Government, (B) used in whole or in part by the Government for manufacture, or (C) used by a party other than the Government. After the expiration of the two (2) year period, the Government may use, duplicate, or disclose the data, in whole or in part and in any manner, for Government purposes only, and may have or permit others to do so for Government purposes only. All rights to use or duplicate the data in whole or in part for commercial purposes are retained by the Contractor, and others to whom this data may be disclosed agree to abide by this commercial purposes limitation. The Government assumes no liability for use or disclosure of the data by others for commercial purposes. This legend shall be included on any reproduction of this data, in whole or in part.

Para. 35.532.15 DoD 52.227-7025

Unclassified

SECURITY CLASSIFICATION OF THIS PAGE

ADA 181491

REPORT DOCUMENTATION PAGE

1a. REPORT SECURITY CLASSIFICATION Unclassified			1b. RESTRICTIVE MARKINGS			
2a. SECURITY CLASSIFICATION AUTHORITY			3. DISTRIBUTION/AVAILABILITY OF REPORT Approved for public release; Distribution unlimited			
2b. DECLASSIFICATION/DOWNGRADING SCHEDULE						
4. PERFORMING ORGANIZATION REPORT NUMBER(S) AFB-0104-FM-8660-79			5. MONITORING ORGANIZATION REPORT NUMBER(S) AFOSR TR 87-0628			
6a. NAME OF PERFORMING ORGANIZATION Foster-Miller, Inc.		6b. OFFICE SYMBOL (If applicable)	7a. NAME OF MONITORING ORGANIZATION AFOSR/NC			
6c. ADDRESS (City, State and ZIP Code) 350 Second Ave. Waltham, MA 02254			7b. ADDRESS (City, State and ZIP Code) Building 410 Bolling AFB, DC 20332-6448			
8a. NAME OF FUNDING/SPONSORING ORGANIZATION AFOSR		8b. OFFICE SYMBOL (If applicable) NC	9. PROCUREMENT INSTRUMENT IDENTIFICATION NUMBER F49620-86-C-0104			
8c. ADDRESS (City, State and ZIP Code) Building 410 Bolling AFB, DC 20332-6448			10. SOURCE OF FUNDING NOS.			
			PROGRAM ELEMENT NO. 61102F	PROJECT NO. 3005	TASK NO. A1	WORK UNIT NO.
11. TITLE (Include Security Classification) Ordered Polymer Nonlinear Optical Materials						
12. PERSONAL AUTHOR(S) Paul J. Marinaccio, Mark A. Druy						
13a. TYPE OF REPORT Final		13b. TIME COVERED FROM 9/86 TO 2/87		14. DATE OF REPORT (Yr., Mo., Day) 87 April		
15. PAGE COUNT 29						
16. SUPPLEMENTARY NOTATION						
17. COSATI CODES			18. SUBJECT TERMS (Continue on reverse if necessary and identify by block number)			
FIELD	GROUP	SUB. GR.	Third Order Nonlinear Susceptibility Ordered Polymers, $\chi^{(3)}$ PBT			
20	06					
19. ABSTRACT (Continue on reverse if necessary and identify by block number) Polyphenylene benzobisthiazole (PBT) has been shown to have a significant third order nonlinear optical effect. Shear orientation, extrusion and quench conditions, post chemical treatments, and post thermal treatments under a variety of conditions all influence the film's nonlinear optical properties. These variables can alter the nonlinear effects since they affect the degree of molecular alignment, the orientation through the film cross section, the degree of crystallinity and the optical quality. In particular, it was found that heat treating the film after extrusion, while improving the mechanical properties, diminished the value of the third order nonlinear optical susceptibility ($\chi^{(3)}$). These results indicate that heat treating may introduce scattering defects into the films causing a decrease in $\chi^{(3)}$. A Phase II program should address the following issues: continued development of ordered polymer processing so to improve optical quality of films, modification of the PBT backbone might be desirable in order to enhance the value of $\chi^{(3)}$ and to improve processibility.						
20. DISTRIBUTION/AVAILABILITY OF ABSTRACT UNCLASSIFIED/UNLIMITED <input checked="" type="checkbox"/> SAME AS RPT <input type="checkbox"/> DTIC USERS <input type="checkbox"/>			21. ABSTRACT SECURITY CLASSIFICATION Unclassified			
22a. NAME OF RESPONSIBLE INDIVIDUAL Dr. Donald Ulrich			22b. TELEPHONE NUMBER (Include Area Code) (202) 767-4963		22c. OFFICE SYMBOL NC	

TABLE OF CONTENTS

<u>Section</u>		<u>Page</u>
1.	INTRODUCTION.....	1
1.1	Objectives/Results of the Phase I Program....	3
2.	EXPERIMENTAL PROCEDURES.....	5
2.1	Measurement of Nonlinear Optical Properties.....	12
3.	CONCLUSIONS.....	15
3.1	Potential Source of Scattering Defects During Processing.....	15
3.2	Recommendations for Phase II Program.....	15



Accession For	
NTIS CRA&I	<input checked="" type="checkbox"/>
DTIC TAB	<input type="checkbox"/>
Unannounced	<input type="checkbox"/>
Justification	
By	
Distribution /	
Availability Codes	
Dist	Avail and/or Special
A-1	

LIST OF ILLUSTRATIONS

<u>Figure</u>		<u>Page</u>
2-1	Wet Coagulated PBT Microstructure.....	6
2-2	Extruder, Coagulation, and Take-up System.....	7
2-3	PBT Biaxial Film Process.....	7
2-4	PBT Surface Defects via Optical Microscopy.....	9
2-5	Foster-Miller PBT Thin Film Deposition Process.....	10
2-6	Scanning Electron Micrograph of Thin PBT Film Supported on Membrane.....	11
2-7	Optical Microscope Picture of PBT Deposited Film.....	12
2-8	Degenerate Four Wave Mixing.....	13
3-1	Current Status of $\chi^{(3)}$ Organic Materials and Potential for PBT.....	17
3-2	Foster-Miller Recommended Approach for Phase II.....	18
3-3	Planar Waveguide Configuration for Measuring Optical Quality.....	18
3-4	Surface Plasmon Configuration for Measuring Optical Quality.....	19
3-5	Electric Field Orientation and Evaporation of Solvent from PBT.....	21
3-6	Proposed Articulated PBT Synthesis and Polymerization.....	22
3-7	Structure of Articulated Monomer and Polymer....	23
3-8	Synthetic Route to Derivatized Terephthalic Monomers with Electron Releasing Groups.....	24

LIST OF TABLES

<u>Table</u>		<u>Page</u>
1-1	Summary of Phase I Goals/Achievements.....	3
1-2	Effect of Process Conditions on $\chi(3)$	4
2-1	Physical Properties of PBT.....	5
3-1	Origins and Solutions to Defects in Deposited PBT Films.....	15

1. INTRODUCTION

Nonlinear optical effects have emerged at the forefront of research because of their importance in optical signal processing, digital optical switching, and optical logic (1-3). The potential speed (subpicosecond) and large bandwidth capability of optical devices, and their capability for parallel processing of information makes optical signal processing and optical computers very attractive. The requirements of all optical signal processing and optical computing require a combination of properties in materials that favor the development of organic and polymeric materials (4).

The electro-optic properties of conjugated polymeric systems such as the ordered polymers result from electronic (π -electrons) transitions rather than physical orientational motion of the molecules or molecular segments. The electro-optic properties resulting from the interaction of light with the electronic transitions in the polymer manifest as the third-order nonlinear susceptibility, ($\chi^{(3)}$). Material requirements for nonresonant third-order processes are extensive π delocalization, transparency in the spectral region of interest, a high degree of molecular order, and excellent optical quality of the polymeric material such that there is a minimization of scattering by the incident beam.

Ordered polymers potentially offer the unique advantages of:

- Liquid crystalline order with the possibility of matching electric field direction to orientation of polymer
- Fast response (subpicosecond)

- Useful optical window for signal processing
- High laser damage threshold
- Potential to molecularly engineer properties and process into desired architectures.

over existing inorganic materials such as lithium niobate and potassium hydrogen phosphate.

Poly-p phenylene benzobisthiazole (PBT) is the subject of recent studies because of its high laser damage threshold and a value of $\chi^{(3)}$ of 2.7×10^{-11} esu (more than an order of magnitude higher than that of CS_2 (5)).

The environmental stability of PBT along with its excellent mechanical properties make it an excellent candidate for opto-electronic device applications. To be suitable for applications, however, higher values ($\sim 10^{-9}$ esu) and improved optical quality of the films is required. Optical quality will be defined as:

- Optical transparency
- Optical flatness.

Improved optical quality in ordered polymers can be obtained in a processing technology which minimizes stress birefringence and void formation.

1.1 Objectives/Results of the Phase I Program

The objective of the Phase I program was:

- To determine the effect of process conditions on the nonlinear optical properties, specifically the third-order nonlinear susceptibility, $\chi^{(3)}$, of PBT.

The variables in the process conditions were:

- Heat treating versus air drying of extruded films
- Introducing sol-gel interpenetrants into the microfibrillar morphology of PBT during processing.

In addition, a thin film deposition process which used a spreading bar to deposit controlled thickness dopes which could be subsequently coagulated into thin films was developed.

Table 1-1 summarizes the goals/achievements of the Phase I effort.

The parameters affected by processing are (i) beam attenuation due to defect absorption and scattering losses; (ii) packing density variation and (iii) order in the film. A comparative study of the four films was made with the degenerate four wave mixing (DFWM) method using 2 ps pulses. The wavelength used was 602 nm. The results are listed in

Table 1-1. Summary of Phase I Goals/Achievements

Goal	Achievement
Determine effect of heat treating	Heat treating does not improve $\chi^{(3)}$
Determine effect of introducing sol-gel interpenetrants	Introduction of sol-gel interpenetrants reduces $\chi^{(3)}$ by 30 percent

Table 1-2. For three films, which were extrusion processed, successful measurements of $\chi^{(3)}$ were made. In the case of the thin film deposited material, the measurement did not succeed because the films did not have good optical quality when made of comparable thickness ($\gg 1\mu$). All three extrusion processed biaxial films were found to show anisotropic $\chi^{(3)}$ values representative of a fourth rank tensor. The values of $\chi^{(3)}$ in the table are for a maximum value for each film obtained as a function of film rotation. This work for the first time establishes the dependence of $\chi^{(3)}$ on processing conditions. The biaxial film which was extruded and only the air dried film gave the highest value of $\chi^{(3)}$. This film also had the lowest optical loss as determined by optical transmission study.

These results indicate that heat treating may introduce scattering defects into the films and thus lower $\chi^{(3)}$. Also, if the refractive index of the sol-gel material is higher than assumed during the measurement, the actual $\chi^{(3)}$ of the sample would be higher. Therefore, if one can introduce a material into the PBT matrix which minimizes scattering, this would be an important processing aid for ordered polymers as nonlinear optical materials.

Table 1-2. Effect of Process Conditions on $\chi^{(3)}$ of PBT

Sample	Description	$\chi^{(3)}$, esu
216.040.01	Biaxially extruded, air dried at 22°C, thickness: 10m	2.7×10^{-11}
216.040.02	Biaxially extruded, stage dried to > 200°C, thickness: 10m	9.0×10^{-12}
216.040.03	Biaxially extruded, infiltrated with borosilicate sol-gel glass (30 percent), air dried at 22°C, thickness: 20m	$2.2 \text{ by } 10^{-12}$
216.040.05A	Thin film deposition, air dried, thickness: 0.25m	Unable to measure

2. EXPERIMENTAL PROCEDURES

The following paragraphs describe the experimental procedures used to obtain the results in the Phase I effort.

The development of polymer synthesis procedures by SRI International (6) involving the use of P_2O_5 additions during synthesis results in a high molecular weight polymer dope consisting of a complex mixture of PBT in polyphosphoric acid (PPA). This dope has been developed to allow fibers to be spun by modified wet spinning techniques. Foster-Miller has developed, under Air Force contract, a film process for producing high strength, high temperature ($>600^\circ\text{C}$) biaxial film from the lyotropic liquid crystalline polymer. This polymer and the film process was originally developed for the purpose of using it as an aerospace structural material. Table 2-1 details the physical properties of PBT films (as produced by the Foster-Miller process) and fibers.

Table 2-1. Physical Properties of PBT

	Ultimate Tensile Strength	Tensile Modulus
PBT Fiber	500,000 psi	$55(10^6)$ psi
High strength film		
Machine direction	280,000 psi	$20(10^6)$ psi
Transverse direction	10,000 psi	$0.1(10^6)$ psi
Balanced biaxial film		
Machine direction	80,000 psi	$10(10^6)$ psi
Transverse direction	80,000 psi	$10(10^6)$ psi
Density	0.055 lb/in.^3	(1.56 gm/cc)
Dielectric constant	2.8 to 3.2	1 kHz to 1 MHz
Maximum temperature before degradation in air	600°C	

The development at Foster-Miller has involved the design of a counter-rotating blown film die and process to impart biaxial orientation to the polymer during extrusion and blowing of the film. The complete process involves dope homogenization, and the use of an extruder to feed a gear pump which in turn feeds the counter-rotating die. A bubble film is blown and immediately quenched in a water bath. This bath serves to coagulate the film structure, hydrolyze the PPA and exchange the resulting phosphoric acid for water. At this state the film is highly water-swollen, porous, and extremely strong (Figure 2-1).

Drying of this film, followed by heat-treatment in stages, produces the high modulus, high tensile strength film for structural applications. Figures 2-2 and 2-3 show the process details and equipment diagram.

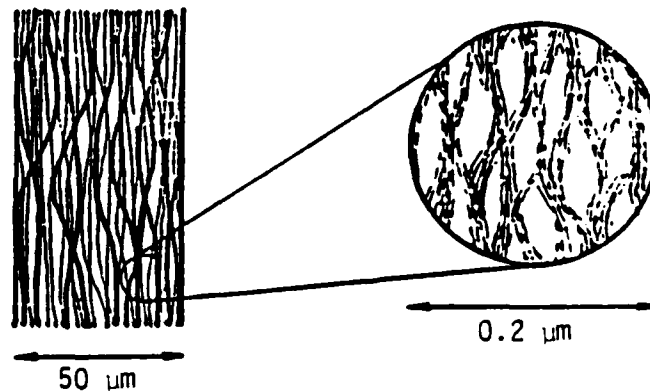

Figure 2-1. Wet Coagulated PBT Microstructure

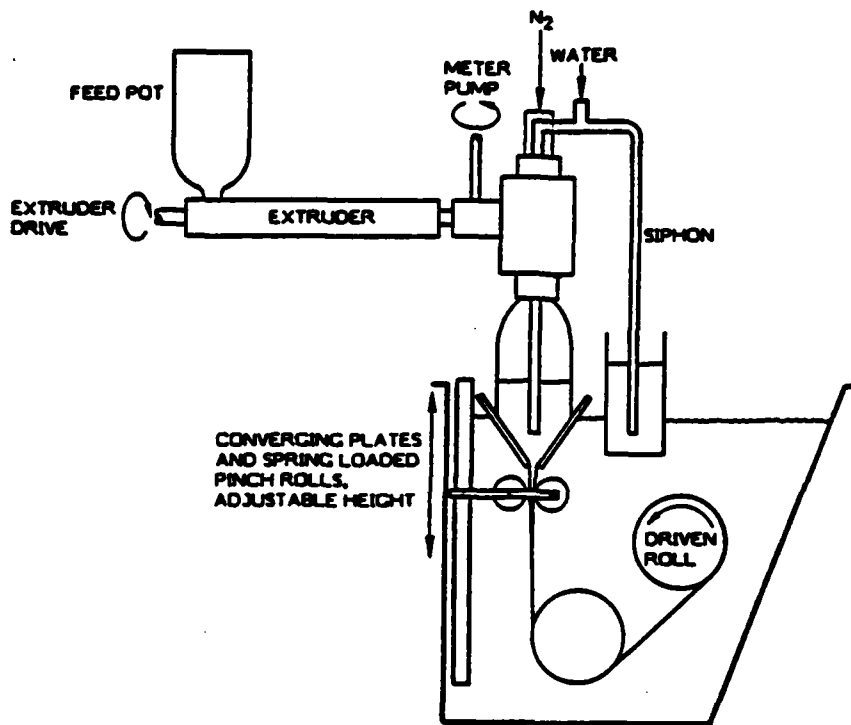

Figure 2-2. Extruder, Coagulation, and Take-up System

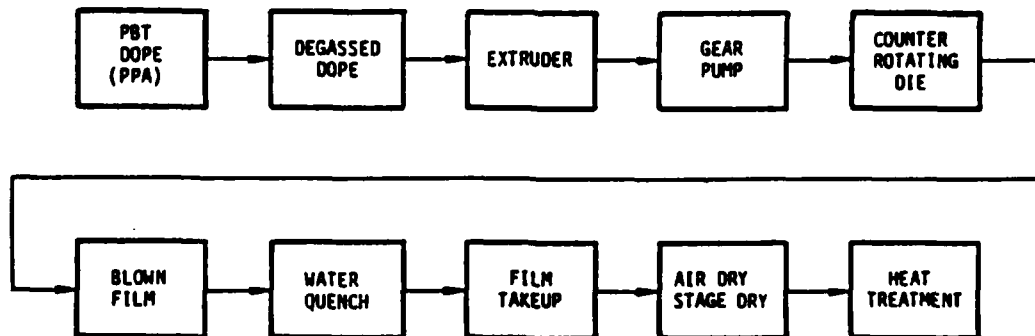

Figure 2-3. PBT Biaxial Film Process

The films studied in the Phase I effort were generally processed as described above and values of $x^{(3)}$ were determined as a function of process conditions.

The extrusion conditions for the films are detailed below:

Dope flow rate: 9 cc/min
Counter-rotational shear: 3.9 rev/sec
Blowout: 1.2
Linear speed: 5.3 ft/min
Linear draw: 45
Film length: 10 ft

Sample 216.040.01 was simply air dried in a ring which provided tension during the drying process.

The stage drying cycle used for sample 216.040.02 was as follows:

1. 0.5 hr room temperature
2. 2.5 hr 174^oF
3. 1.25 hr from 174 to 250^oF
4. 1.25 hr from 250 to 480^oF
5. 1.25 hr at 480^oF

Sample 216.040.03 was soaked in a sodium borosilicate sol-gel prior to air drying. The composition of the sol-gel solution was as follows:

SiO₂ 82 wt. %
B₂O₃ 12 wt. %
Na₂O 6 wt. %

Although the values reported in Table 1-2 are high and are extremely exciting, it is imperative that optical quality of the films be improved such that it would be possible to

propagate light through a waveguide composed of PBT film. The optical microscope picture shown in Figure 2-4 reveals the defects present in the film (caused by stress birefringence and void formation) which would ultimately result in large and unacceptable scattering losses in the film. Concepts for improving the optical quality of ordered polymers will be presented in subsection 3.2.

In order for PBT to be used as a potential waveguide material, it is necessary to develop the ability to produce ultra-thin films of PBT for nonlinear optical applications. Foster-Miller, as part of the Phase I effort, developed a thin film deposition process. A block diagram of this process is shown in Figure 2-5.

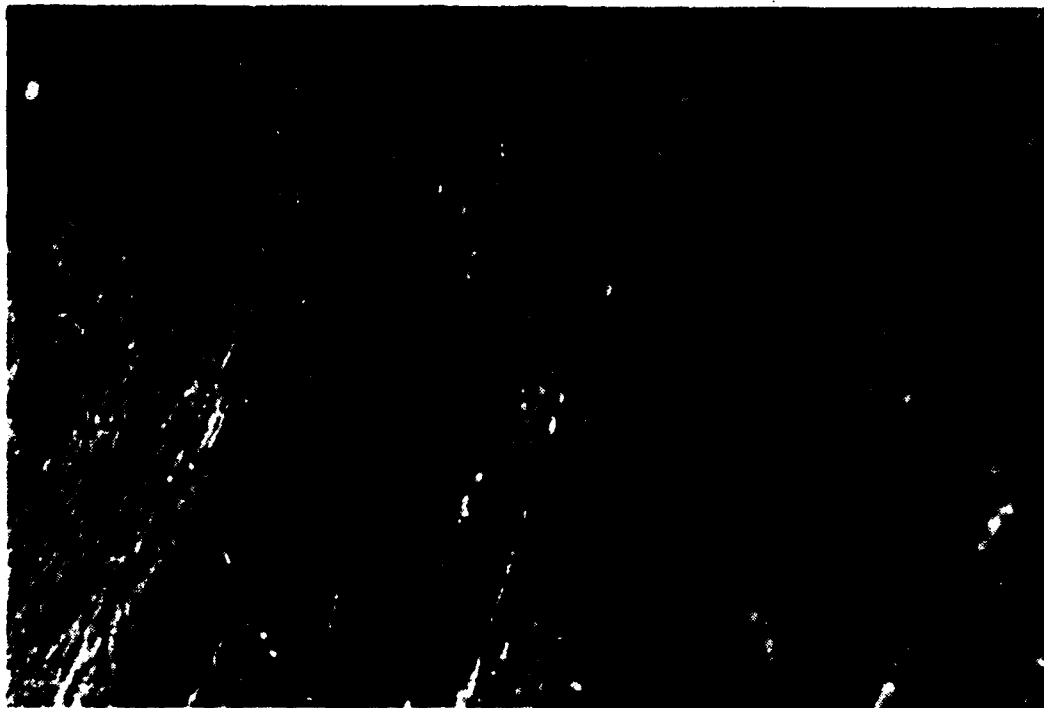

Figure 2-4. PBT Surface Defects via Optical Microscopy

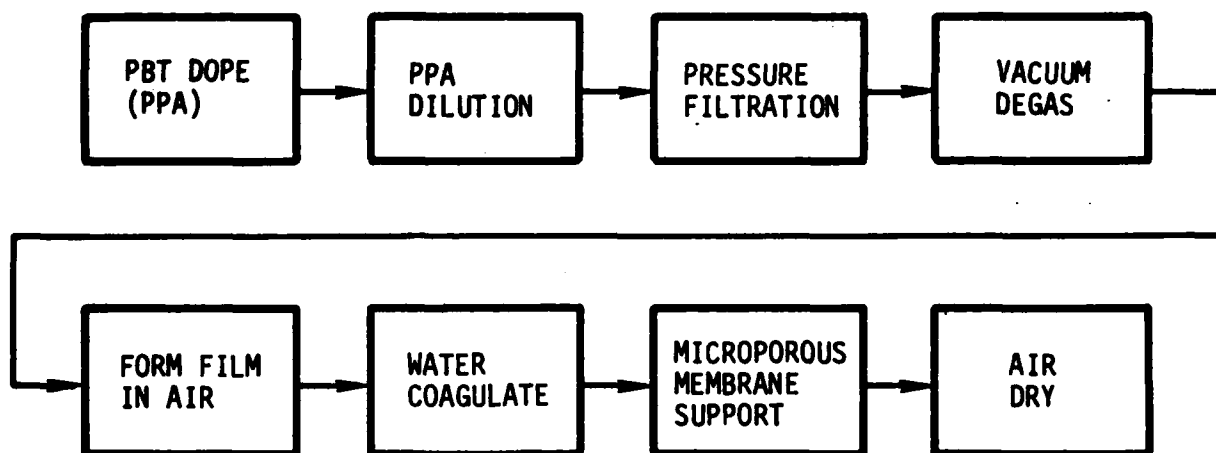

Figure 2-5. Foster-Miller PBT Thin Film Deposition Process

The process involves dilution of the PBT PPA dope with additional PPA. The starting material for this was: PBT #2894-64 from SRI; 5.5 wt. % PBT in PPA; $[\eta]_{\text{MSA}} = 18$ dL/g. A quantity of this dope was blended with additional diluent PPA to a concentration of 0.78 wt. % PBT with a high shear mixer under elevated temperatures. This material was then filtered through a high pressure AMICON 401 S filtration cell and subsequently diluted to 0.45 wt. % PBT with MSA. The thin films were deposited on clean glass plates with a bird-type multiple clearance thin film applicator. Once coated onto glass, they were coagulated in water. After 5 to 10 min. the films spontaneously lift from the glass and float freely in the water. They were then allowed to soak for 24 hr. to allow any MSA or PPA to diffuse out of the water-swollen film. While in water, they are optically transparent and yellow. Samples of the film were then mounted on glass slides or in an o-ring. Films as thin as 0.2μ have been prepared using these

methods. These thin films can be picked up on any suitable substrate such as a glass slide and then dried. Figure 2-6 shows a scanning electron micrograph of the surface of this film on a nylon support membrane. The fibrillar structure in the lower left portion of the figure is the support membrane, and the smoother structure in the upper right portion of the figure is the PBT film. The edge view of the PBT film reveals that the thickness is $\sim 0.25\mu$. Figure 2-7 is an optical microscope picture of the film.

Figure 2-7 reveals what appears to be spherulite-like structures on a smooth background. This film was judged to be largely isotropic judging by the absence of birefringence under crossed polarizers. To the naked eye, these films are transparent yellow although they have a slight haziness to them, most likely as a result of the spherulite-like structures.

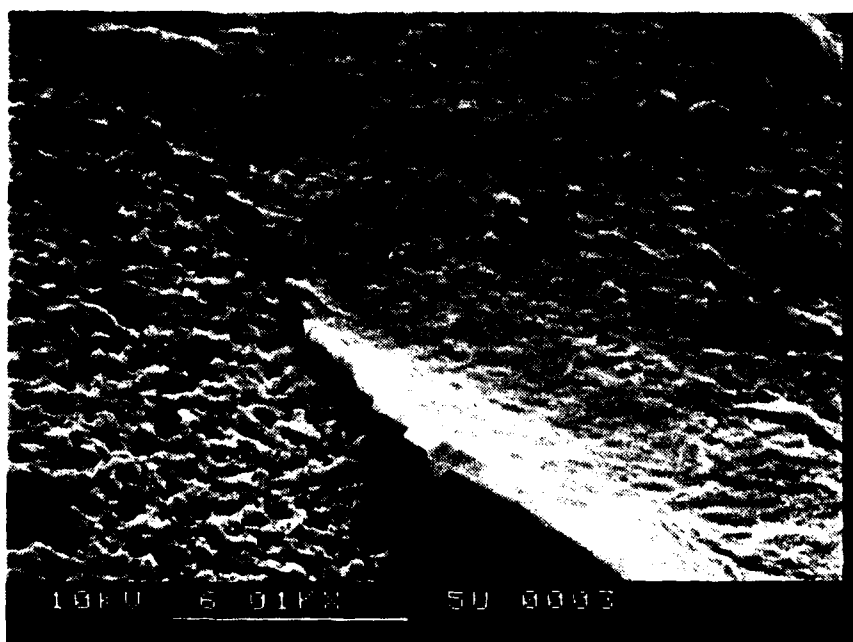

Figure 2-6. Scanning Electron Micrograph of Thin PBT Film Supported on Membrane

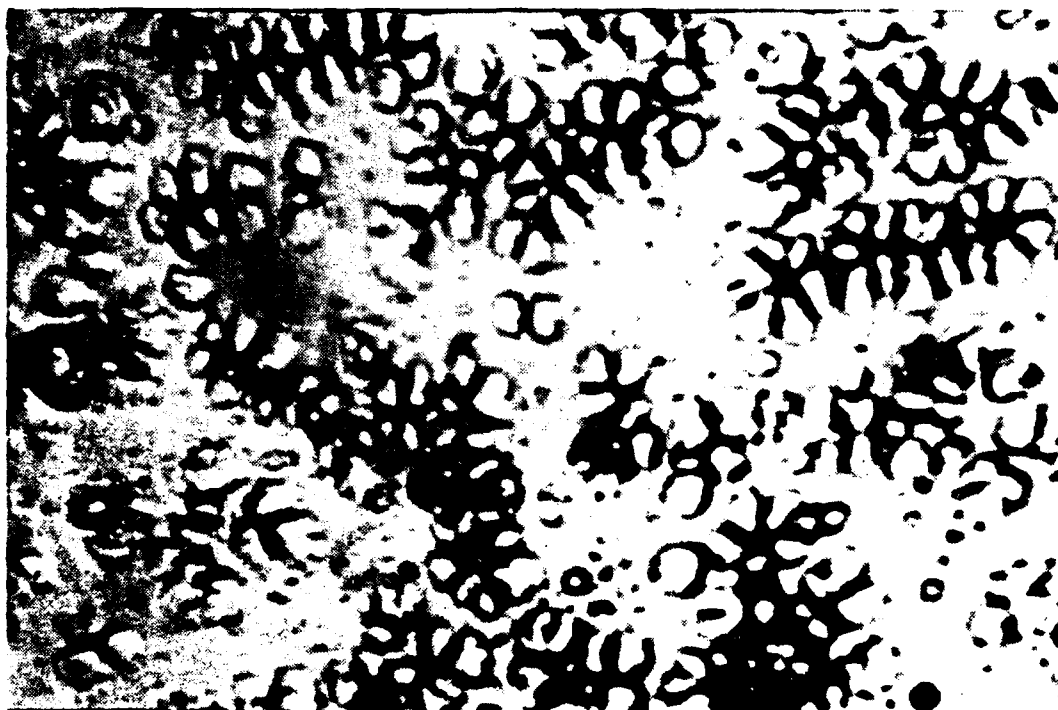
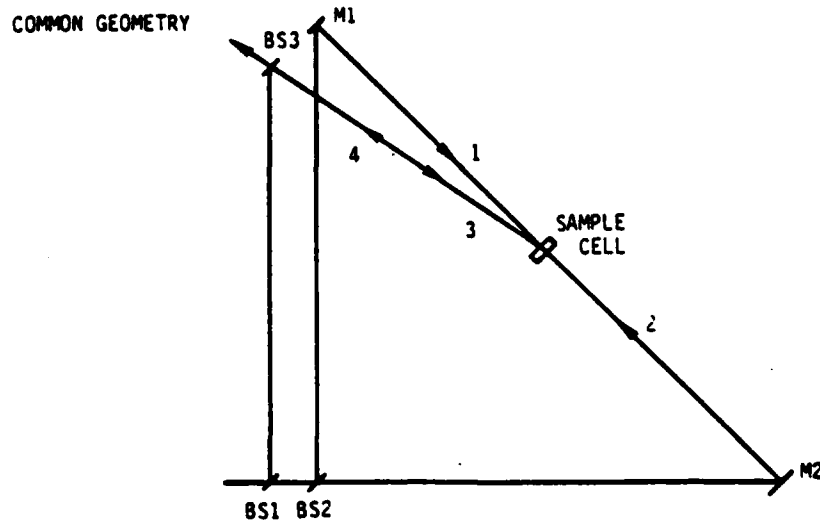

Figure 2-7. Optical Microscope Picture of PBT Deposited Film

2.1 Measurement of Nonlinear Optical Properties

In a third-order nonlinear optical process ($\chi^{(3)}$ process) three laser beam inputs: $I(W_1)$, $I(W_2)$, $I(W_3)$ interact in a nonlinear medium to produce a coherence field at a phase matched angle at a frequency W_4 . Two important $\chi^{(3)}$ processes are: a) third harmonic generation, and b) degenerate four wave mixing (DFWM). In the third harmonic generation $W_1=W_2=W_3=W$ and $W_4=3W$. In the DFWM process $W_1=W_2=W_3=W_4$. This $\chi^{(3)}$ process has received more attention because of its application to optical logic, bistability, and dynamic holography. In the case W_1 and W_2 are counterpropagating, the phase matching condition requires that the DFWM signal ($W_4(-W_1=W_2=W_3)$) be counter-propagating to W_3 as shown in Figure 2-8. In other words, the beam W_3 reverses its path generating a phase conjugate. We plan to use DFWM for measuring $\chi^{(3)}$. The advantage of this method over

THREE WAVES OF EQUAL FREQUENCY INTERACT IN THE MEDIUM BY THIRD ORDER NON-LINEAR OPTICAL INTERACTIONS ($\chi^{(3)}$) TO GENERATE A FOURTH WAVE OF SAME FREQUENCY.



1 AND 2 COUNTER PROPAGATE, THE SIGNAL 4 IS THEN THE PHASE CONJUGATE OF 3

Figure 2-8. Degenerate Four Wave Mixing

the third harmonic generation method is that one can get both values of $\chi^{(3)}$ and its response time. The DFWM signal can arise from many contributions, however, such as (i) electronic third-order nonlinear susceptibility (electronic contribution to $\chi^{(3)}$), (ii) orientational third-order susceptibility, (iii) electrostriction, and (iv) thermal grating. On the basis of time response and effect of relative polarization of the three beams the various contributions to DFWM can be separated. The π electron contribution to the DFWM signal has the fastest response time, being in subpicoseconds. When the frequency of the laser beam is far from any electronic resonance, the DFWM signal derived from electronic contributions is a nonresonant contribution due to the resonant state. In order to separate electronic nonresonant contributions from other contributions, one needs to conduct DFWM experiments with ultrashort laser pulses. The laboratory of Professor Prasad is ideally suited for these experiments.

The laser system used for this investigation at Buffalo consists of CW mode-locked Nd-Yag laser (Spectra-Physics, Model 3000), the output of which after frequency doubling sync pumps a dye laser (Spectra-Physics, Model 375). The output from the sync pumped dye laser is fed into an amplifier (Quanta Ray, Model PDA), which is pumped by a 20 Hz pulsed Nd-Yag laser (Quanta Ray, Model DCR-2A). The output from the amplifier is a pulse width ~ 8 psec and energy ~ 0.5 mJ. For subpicosecond response study, a saturable absorber DQOCI solution is added to the dye in the sync pumped dye laser which shortens its pulses to ~ 350 fsec. However, the pulse broadens about 3 times after the amplification. A backward pump wave geometry will be used for the DFWM experiment. In this geometry, the output from the amplifier after being appropriately attenuated by neutral density filters is split in two. One portion is sent through the optical delay line and forms the backward pump wave. The other portion is again split in two beams of unequal intensity: a weak probe beam and stronger forward pump beam; these two are crossed at an angle of ~ 5 deg in the film.

3. CONCLUSIONS

3.1 Potential Source of Scattering Defects During Processing

Although it was demonstrated that thin films could be deposited from dilute solutions of PBT in PPA, it was not possible to measure $\chi^{(3)}$ for these films because of extensive scattering defects present in the film. The origins of these defects and possible solutions to their formation are summarized in Table 3-1.

3.2 Recommendations for Phase II Program

In order to develop optical switching devices using nonlinear optical processes in an optical waveguide, the intensity-dependent refractive index for a specific guided mode is utilized. The relevant parameters for optimal device performance are the attenuation, α ; homogeneity of the waveguide defined by the refractive index variation, Δn ; and optical flatness so that the waveguide supports the propagation of a specific guided mode. The requirement for α , which

Table 3-1. Origins and Solutions to Defects in Deposited PBT Films

<u>Origin</u>	<u>Solution</u>
Impurities, particles, agglomerates in the deposited film	Deposition in particle free environment
Voids, residual stress birefringence	Use wet coagulated film or replace water with refractive index matching material. Slow coagulation, orient in magnetic field or use electric field deposition

limits throughput, is $\alpha < \text{few cm}^{-1}$. The refractive index homogeneity requirement is $\Delta n < n_2 I$ where n_2 is the intensity dependent refractive index. For PBT $|_2| \sim 10^{-7} \text{ cm}^2/\text{Mw}$, but it is expected that $n_2 I$ may reach a saturation value of 10^{-3} . Therefore, the refractive index variation Δn due to inhomogeneity must be less than 10^{-4} which requires the thin film to be highly uniform. For a waveguide to support a specific guided mode, the film thickness must have a uniformity (optical flatness) of at least $\lambda/10$.

Therefore, a Phase II program will address the following issues:

- Continued development of ordered polymer processing from the standpoint that ordered polymers such as PBT and PBO are potential nonlinear optical materials and, as a result, optical transparency (homogeneity) and optical flatness must be greatly improved
- In order to enhance processibility and perhaps the value of $\chi^{(3)}$, modification of the PBT backbone will be necessary.

The Phase I program showed that ordered polymers, in particular, PBT, have potential as $\chi^{(3)}$ materials, but currently are limited by light scattering and other optical defects. The results of addressing the above issues in the Phase II program will be to provide a simple and reliable method to make defect-free ordered polymer film with improved optical properties and enhanced values of $\chi^{(3)}$. Figure 3-1 summarizes the current status of organic $\chi^{(3)}$ materials and the potential for PBT.

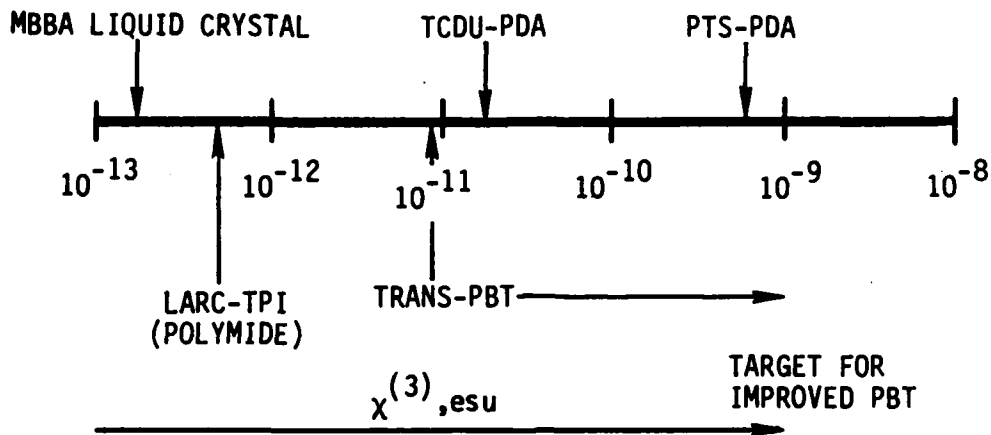

Figure 3-1. Current Status of $\chi^{(3)}$ Organic Materials and Potential for PBT

The Phase II program will be characterized by a parallel approach indicated in Figure 3-2 with the ultimate goal of obtaining enhanced $\chi^{(3)}$ and optical quality in ordered polymers typified by PBT.

In the Phase II program optical quality will be assessed at the State University of New York-Buffalo (in the laboratories of Professor Paras Prasad). Both a planar waveguide and a surface plasmon configuration will be used. In the planar waveguide configuration (Figure 3-3) a thin film of polymer ($\sim 1\mu$ thickness) will be deposited on a glass slide. Prism coupling will be used to guide a HeNe laser line into the film. The requirement is that the refractive index of the prism should be higher than that of the polymer. For this purpose, a prism will be used which has a refractive index of 2.4. A measurement of the propagation distance in the

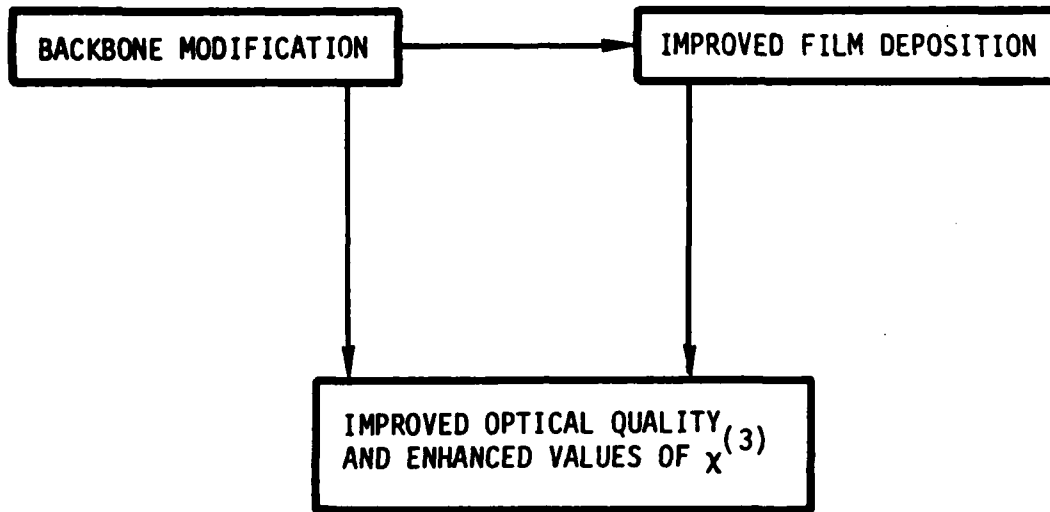

Figure 3-2. Foster-Miller Recommended Approach for Phase II

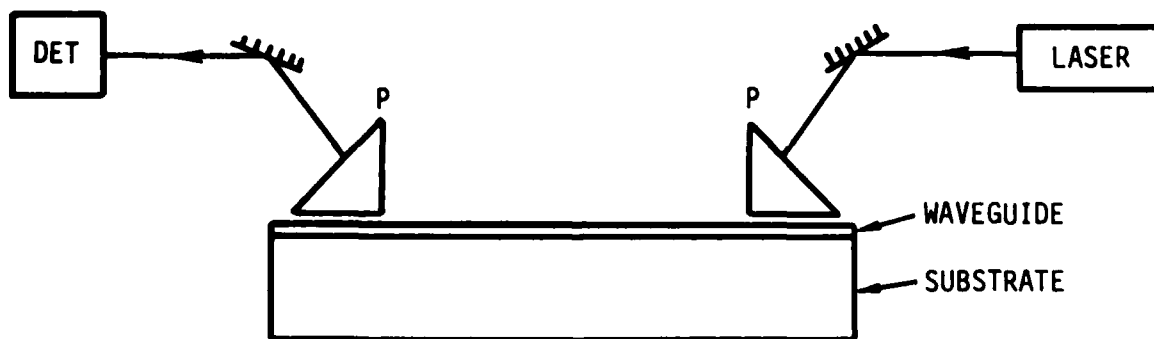

Figure 3-3. Planar Waveguide Configuration for Measuring Optical Quality

waveguide would give us a rough estimate of the attenuation, α in the waveguide to qualitatively assess the optical quality of the films. For a more quantitative estimate on promising films, the coupling efficiency will be determined as a function of propagation distance by measuring both input and output powers. The output power will be measured by using a second prism to decouple the beam from the waveguide as shown in Figure 3-3.

The surface plasmon coupling will assist in evaluating the uniformity of the film. For this study, the polymer film will be coated on a $\sim 400\text{\AA}$ thick silver film deposited on a glass slide. A prism coupling in the Kretschman geometry as illustrated in Figure 3-4 will be used to couple light to a surface plasmon wave. The coupling is defined by an incident angle at which a dip in reflectivity occurs. The surface plasmon propagation distance is about 10μ . From the dip in

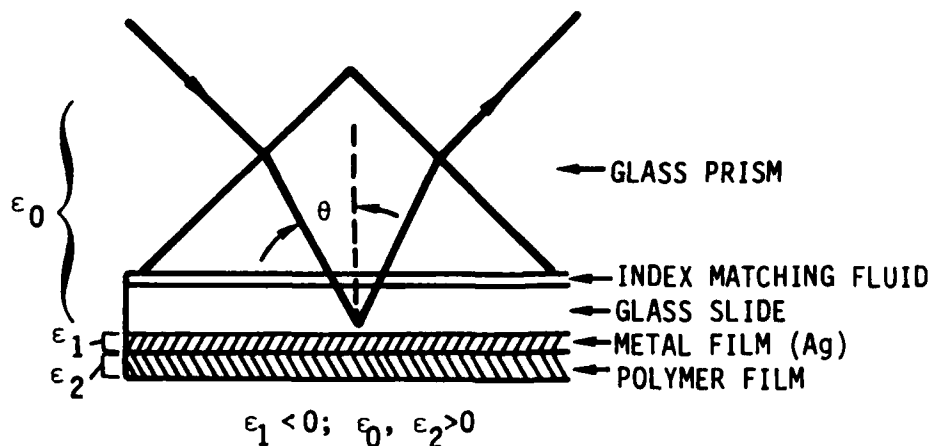

Figure 3-4. Surface Plasmon Configuration for Measuring Optical Quality

reflectivity, one can determine the refractive index as well as the thickness of the film averaged, of course, over a spot of 10 μ size. By translating the film to measure the refractive index and the film thickness at various spots one can map out the spatial homogeneity of the film.

Refinement of the deposition procedure will involve two levels of development. The first level will make the following improvements:

- Improvements in deposition process to minimize particulate impurities
- Slower coagulation times to reduce the tendency to form liquid crystalline defects
- Reducing void formation and stress birefringence.

The second level of development will utilize an electric field (or magnetic field) orientation process concurrent with slow evaporation of solvent from the deposited film. This process will result in orientation of the ordered polymer chains and minimization of voids which are usually formed during coagulation. The presence of voids in the fibril structure is undesirable because they will ultimately contribute to scattering losses.

Molecular modifications to the PBT backbone will focus on two aspects:

- Improved processibility via introduction of articulated linkages
- Enhancements in the value of $\chi^{(3)}$

The introduction of conjugated articulated linkages (flexible swivel groups) between long, ordered polymer chain segments may improve the ability to deposit films of PBT because of increased flexibility in the backbone.

Enhanced $\chi^{(3)}$ might be obtained via the derivation of terephthalic acid monomers with electron releasing groups. This might force more electrons into the conjugated PBT backbone thereby increasing the interaction of the Π electron cloud with the incident light. The result of this increased interaction could be enhanced values of $\chi^{(3)}$.

Modifications of the deposition procedure will involve the development of an electric field orientation process concurrent with slow evaporation of solvent from the deposition film. This apparatus is shown in Figure 3-5.

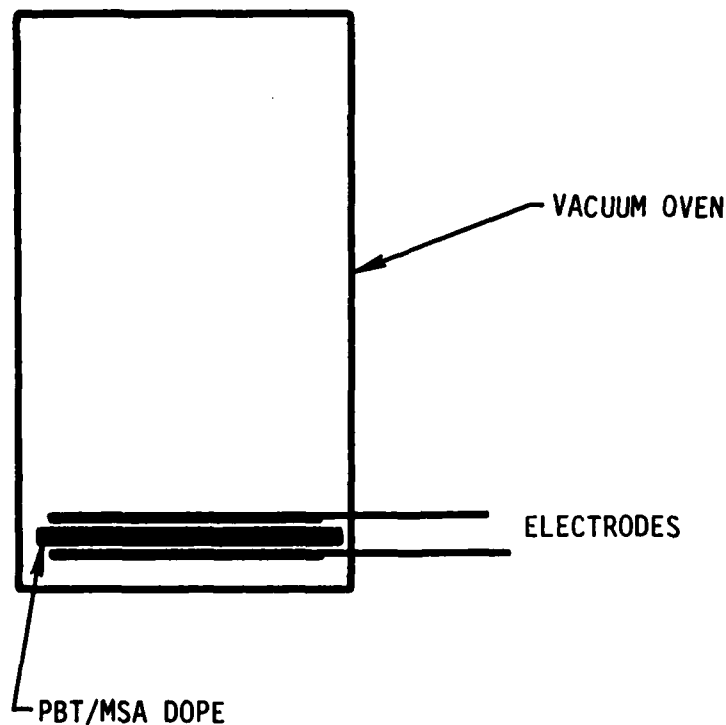

Figure 3-5. Electric Field Orientation and Evaporation of Solvent from PBT

This process will result in orientation of the PBT chains and minimization of voids which are usually formed during coagulation. The presence of voids in the fibril structure is undesirable because they will ultimately contribute to scattering losses.

The introduction of conjugated articulated linkages (flexible swivel groups) between long, ordered polymer chain segments will improve the ability to deposit films of PBT because of increased flexibility in the backbone. Figure 3-6 illustrates the proposed articulated polymer concept using the candidate articulated monomer unit, biphenyl-3,3'-dicarboxylic acid.

Figure 3-7 illustrates the structure of the articulated monomer in the polymer.

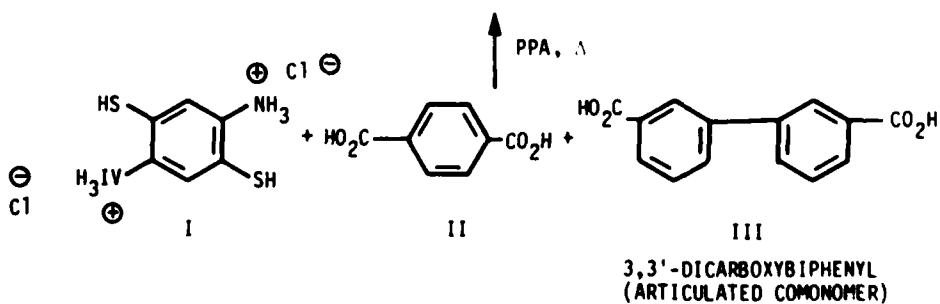
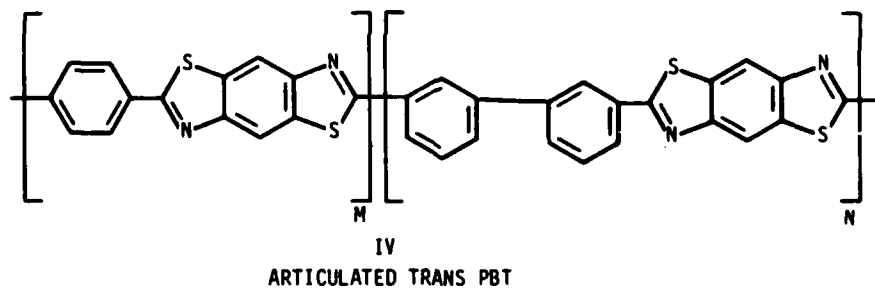

Figure 3-6. Proposed Articulated PBT Synthesis and Polymerization

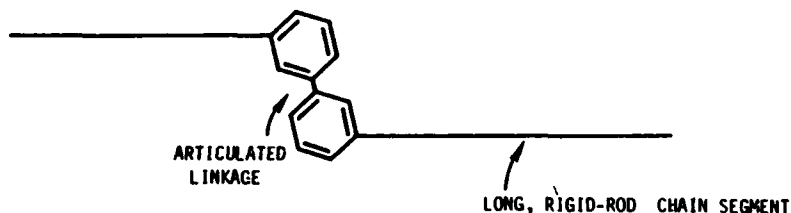
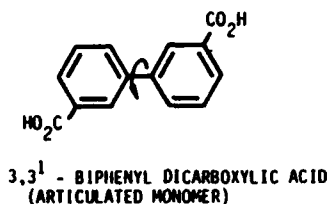
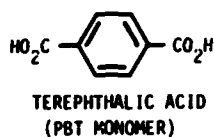

Figure 3-7. Structure of Articulated Monomer and Polymer

Enhanced $\chi^{(3)}$ can be obtained via the derivation of terephthalic acid monomers with electron releasing groups. This would force more electrons into the conjugated PBT backbone thereby increasing the interaction of the π electron cloud with the incident light. The result of this increased interaction will be enhanced values of $\chi^{(3)}$. Figure 3-8 shows the synthetic route to obtain derivatized terephthalic acid monomer units with electron releasing groups.

Successful completion of the Phase II objectives will result in improved ordered polymers with the following characteristics:

- Enhanced values of $\chi^{(3)} > 10^{-12}$ esu
- Greatly increased optical transparency
- Greatly increased optical flatness.

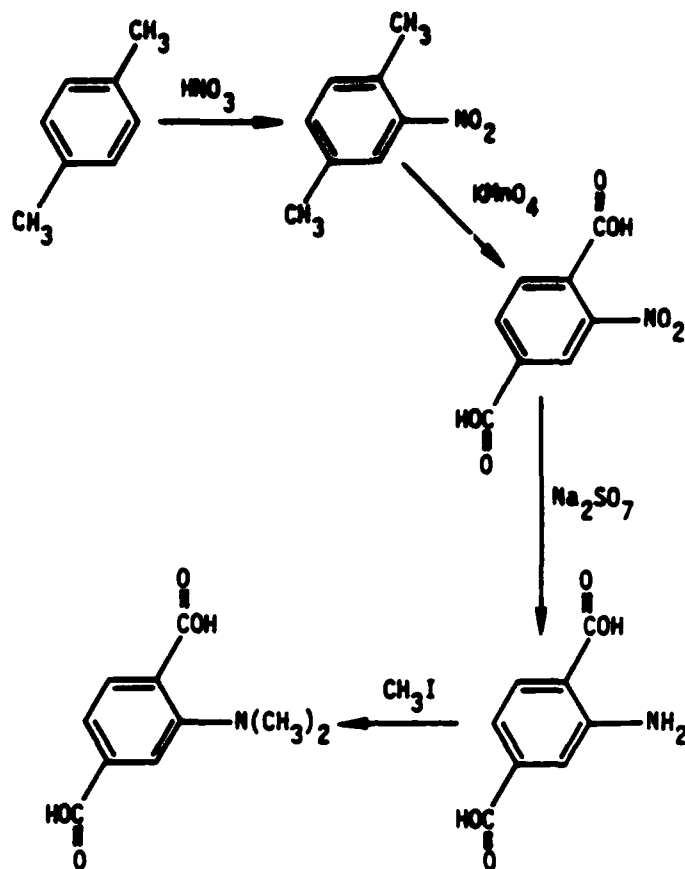

Figure 3-8. Synthetic Route to Derivatized Terephthalic Monomers with Electron Releasing Groups

Utilization of PBT for nonlinear optical applications will only be possible if these characteristics pertain to ordered polymers. Meeting these objectives will expand the technology base for ordered polymer applications.

ENO

7-87

Ditic