

AD-A182 103

DEVELOPMENT OF MULTI-PURPOSE LOW FRAGILITY CONTAINER
SYSTEM FOR SMALL LTG (U) AIR FORCE PACKAGING
EVALUATION AGENCY WRIGHT-PATTERSON AFB OH

1/1

UNCLASSIFIED

L A MOOD
F/G 15/5

NL



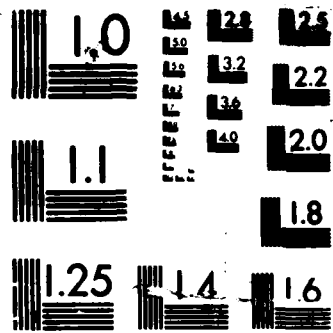

MICROCOPY RESOLUTION TEST CHART

DTIC FILE COPY

12

Approved for Public Release
Distribution Unlimited

DSTZT Report NO: -87-R-02
AFPEA PROJECT NO: 85-P-146

AD-A182 103

LARRY A. WOOD
Mechanical Engineer
AUTOVON 787-4519
Commercial (513) 257-4519

DTIC
ELECTE
JUL 0 2 1987
S **D**

**DEVELOPMENT OF MULTI-PURPOSE LOW FRAGILITY CONTAINER SYSTEM
FOR SMALL, LIGHTWEIGHT ITEMS**

HQ AFLC/DSTZT
Air Force Packaging Evaluation Agency
Wright-Patterson AFB, Ohio 45433

JUNE 1987

NOTICE

When government drawings, specifications, or other data are used for any purpose other than in connection with a definitely related government procurement operation, the United States Government thereby incurs no responsibility whatsoever; and the fact that the government may have formulated, furnished, or in any way supplied the said drawings, specifications, or other data, is not to be regarded by implication or otherwise as in any manner licensing the holder or any other person or corporation, or conveying any rights or permission to manufacture, use, or sell any patented invention that may in any way be related thereto. This report is not to be used in whole or in part for advertising or sales purposes.

AFPEA PROJECT NO: 85-P-146

TITLE: Development of Specialized Protective Pack for Small, Lightweight Items

ABSTRACT

The objective of this project was to develop a multi-purpose pack to provide a protection level of at least 15Gs for small, shock sensitive, lightweight items (such as gyros and electronic components) within the weight range of 1 to 5 pounds. The scope of this effort was later expanded to include items up to 10 pounds using a second pack design.

Two packs were developed that satisfy all requirements. The first pack provided 15G protection for items in the 1 to 4 pound weight range; the second pack provided 15G protection for items in the 4 to 10 pound weight range, thus covering a total weight range of 1 to 10 pounds.



Accession For	
NTIS CRA&I	<input checked="" type="checkbox"/>
DTIC TAB	<input type="checkbox"/>
Unannounced	<input type="checkbox"/>
Justification	
By	
Distribution/	
Availability Codes	
Dist	Avail and/or Special
A-1	

PREPARED BY:

LARRY A. WOOD *L A Wood*
Mechanical Engineer
Materials Engineering Branch

PUBLICATION DATE:

04 JUN 1987

REVIEWED BY:

MATTHEW A. VENETOS *Matthew A. Venetos*
Chief, Materials Engineering Branch
AF Packaging Evaluation Agency

APPROVED BY:

JACK E. THOMPSON *Jack E. Thompson*
Chief, AF Packaging
Evaluation Agency

TABLE OF CONTENTS

ABSTRACT..... i
TABLE OF CONTENTS..... ii
INTRODUCTION..... 1
DESCRIPTION OF TEST PACKS..... 1
INSTRUMENTATION AND EQUIPMENT..... 2
TEST PROCEDURES AND RESULTS..... 2
DISCUSSION..... 3
CONCLUSION..... 4

FIGURES

FIGURE 1: PHOTOGRAPH OF EXTERIOR CONTAINER..... 5
FIGURE 2: PHOTOGRAPH OF CUSHIONING LAYOUT..... 6
FIGURE 3: PHOTOGRAPH OF TEST PACK 1, INNER CONTAINER
AND BALLAST..... 7
FIGURE 4: PHOTOGRAPH OF TEST PACK 2, INNER CONTAINER
AND BALLAST..... 8

APPENDICES

APPENDIX I: TEST DATA, PACK 1..... 9
APPENDIX II: TEST DATA, PACK 2..... 10
APPENDIX III: SPECIAL PACKAGING INSTRUCTION DRAFT,
1 TO 4 POUNDS..... 11
APPENDIX IV: SPECIAL PACKAGING INSTRUCTION DRAFT,
4 TO 10 POUNDS..... 14
DD FORM 1473 REPORT DOCUMENTATION..... 17
DISTRIBUTION LIST..... 18

INTRODUCTION

In January 1986 this agency initiated a project to develop a multi-purpose, low fragility container system for small, lightweight items. Former attempts to develop a system of this type have failed. The success of this effort is believed to be due to two factors. The first was a carefully constructed analytical model, calculated to reduce the number of variables introduced. This was achieved by using a cubical pack, with the resulting symmetry greatly simplifying calculations.

The second reason for success was the innovation of using smooth surfaced cushion covers. The result of this was a reduction in friction, thus allowing the system response to approach theoretical values. → to (1473) p. 17

Analytical models were developed and tested using AFPEA's Package Cushion design computer program. The results of this analysis predicted that with the use of reduced area techniques current technology was suitable, and the use of MIL-P-26514, Type 1, Class 2, Grade A, polyurethane cushioning material would satisfy all requirements.

Most cushioning materials were found to be too stiff to provide adequate dynamic displacement for a lightweight item. The only other alternative, rubberized hair, exhibits both cost and performance drawbacks, making it unsuitable in this application. The material can only be purchased in the required thickness by special order, which is not cost effective, and the performance is degraded over time and repeated use with the material losing its ability to absorb energy as well as developing a compression set.

The computer prediction was confirmed by subsequent testing, the results of which are provided in Appendices I and II.

DESCRIPTION OF THE TEST PACKS

Both containers were fabricated from single wall fiberboard in accordance with PPP-B-636, Style FTC (see figure 1). These containers included a cushioning system consisting of six 8 x 8 x 6 inch polyurethane foam (MIL-P-26514, Type 1, Grade A) cushions. The inner containers are also single wall fiberboard. Size data is listed in Table 1.

TABLE 1 - CONTAINER DATA

Con- tainer	Inner Ctnr OD(In)	Exterior Ctnr ID(In)	Weight Range (Lbs)	Maximum Item Size(In)	Inner Ctnr Net Wt(Lbs)	Total Pack Tare Wt(Lbs)
1	8X8X8	20 1/2X 20 1/2X20 1/2	1-4	7 1/2X 7X6 1/4	5.6	17
2	10X10X10	22 1/2X 22 1/2X22 1/2	4-10	9X 9X9 1/2	3.5	14

In both containers the cushions were covered with MIL-B-131 material with the smooth side out, to reduce friction between the primary container and the cushioning material (see figure 2).

The simulated load was restrained in the inner container by wrapping it in several layers of PPP-C-1752 (1/4 inch thick) polyethylene foam. This material was chosen because it is a common dunnage material, available at the Air Force's Air Logistics Centers (ALCs) and most bases.

INSTRUMENTATION AND EQUIPMENT

The following instrumentation and equipment was employed for this evaluation:

Oscilloscope, Tektronic, 4 channel storage, Model 565B

Accelerometer, tri-axial, Endevco, Model 2233E

Amplifiers (3 ea), Endevco, Model 2424C

Power Supply, Endevco, Model 2622C

Drop Tester, Gaynes, Model 125

TEST PROCEDURES AND RESULTS

The free fall drop tests were conducted in accordance with Federal Test Method Standard 101C, Method 5007, Procedure A, Level B, 27 inch drop height. The test loads consisted of 1 pound, 4 pound, and 10 pound plywood and aluminum models to

simulate actual items. A tri-axial accelerometer was secured at the center of gravity of each test load. The drop test results are summarized in Table II. Complete test data is provided in Appendices I and II.

TABLE II - DROP TEST DATA

Average Peak Acceleration - Gs (Resultants)			
	<u>Sides</u>	<u>Edges</u>	<u>Corners</u>
<u>Container 1</u>			
1 Lb Load	10.2	9.6	9.9
4 Lb Load	13.3	7.6	8.8
<u>Container 2</u>			
4 Lb Load	10.5	12.0	12.7
10 Lb Load	12.3	8.0	6.2

DISCUSSION

During testing, it was noted that when the pack of maximum weight was impacted on corners and edges, the inner container exhibited a tendency to rotate in the cavity. However, as soon as the container was rolled over to an opposite side or edge, the system would return to equilibrium. In no case did the load jam into a corner and impact the exterior container or "bottom out." This is attributed to the smooth surface of the MIL-B-131 cushion covers (see figure 2). When the packs were tested without the cushion covers, the peak G levels were dramatically greater.

In both pack designs it was necessary to add ballast to the inner container to achieve 15G protection over the required weight range. In pack number 1 this was accomplished by the addition of two 7 1/2X7 1/2X3/8 aluminum plates and a fiberboard liner to prevent movement (see figure 3). In pack number 2 the ballast consists of four 9 1/2X9 1/2X1/4 plywood plates adhesively bonded to the inside of the inner container (see figure 4). These methods were selected because of their simplicity and cost effectiveness.

The simulated load was restrained in the inner container by wrapping it with sheets of 1/4 inch thick PPP-C-1752 polyethylene foam. Similar results were achieved using bubble wrap, (PPP-B-795), and polyurethane Foam-In-Place (MIL-P-26514, Type II). Poor results were obtained when prefoamed polyurethane (MIL-P-26514, Type I) was used. This is attributed to a phase shift in the shock pulse that occurs when the cushioning materials in the interior and exterior are of the same type. Since MIL-P-26514, Type I is not commonly used as dunnage, this is not anticipated to be a problem.

CONCLUSION

The two pack designs developed in this study and depicted in appendices III and IV will provide 15G shock protection for a wide variety of items. Both packs are extremely low cost and can be fabricated by any ALC from standard packaging materials. The availability of these containers will provide the logistics system with a cost effective alternative to custom designed shipping containers for each light weight item.

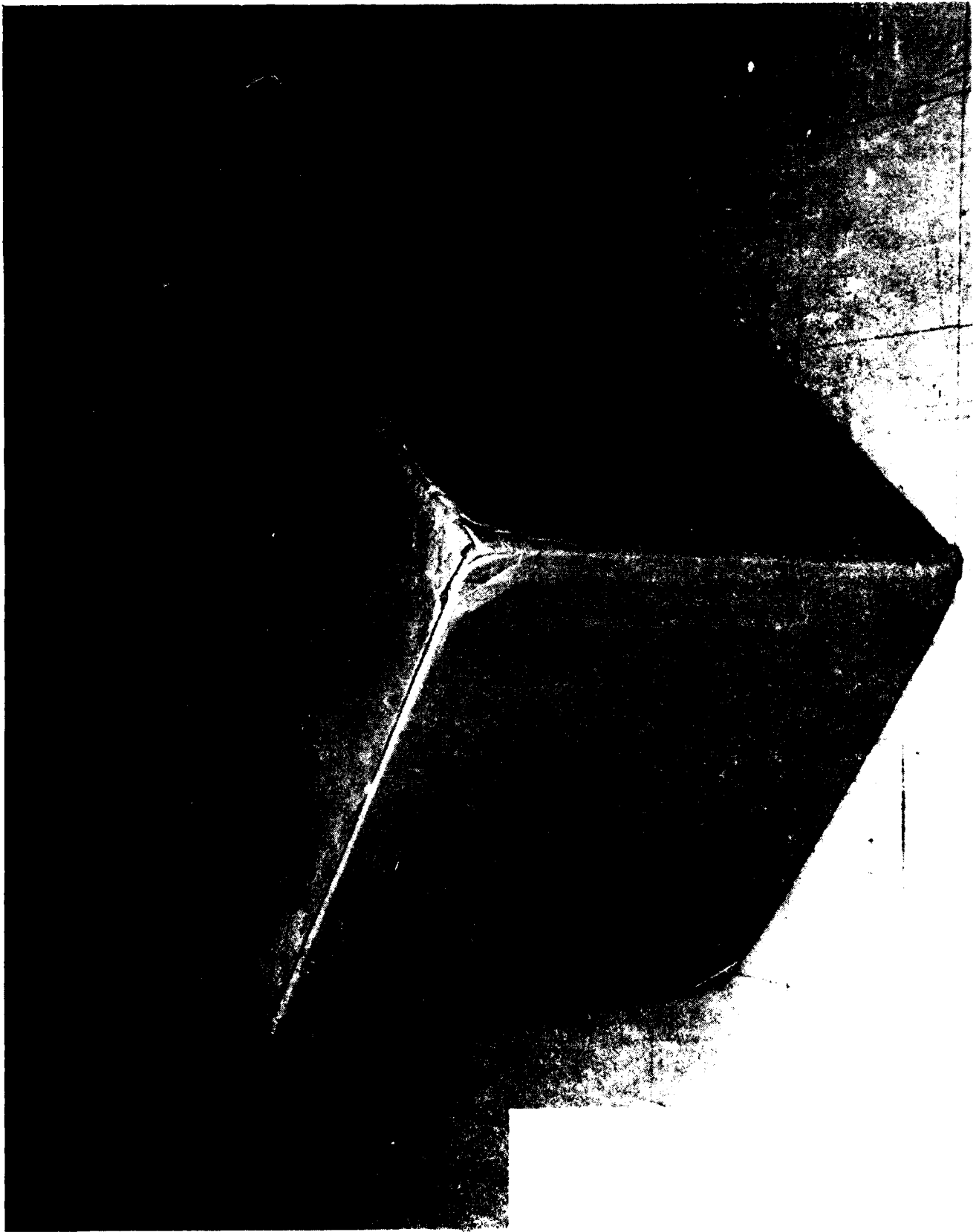

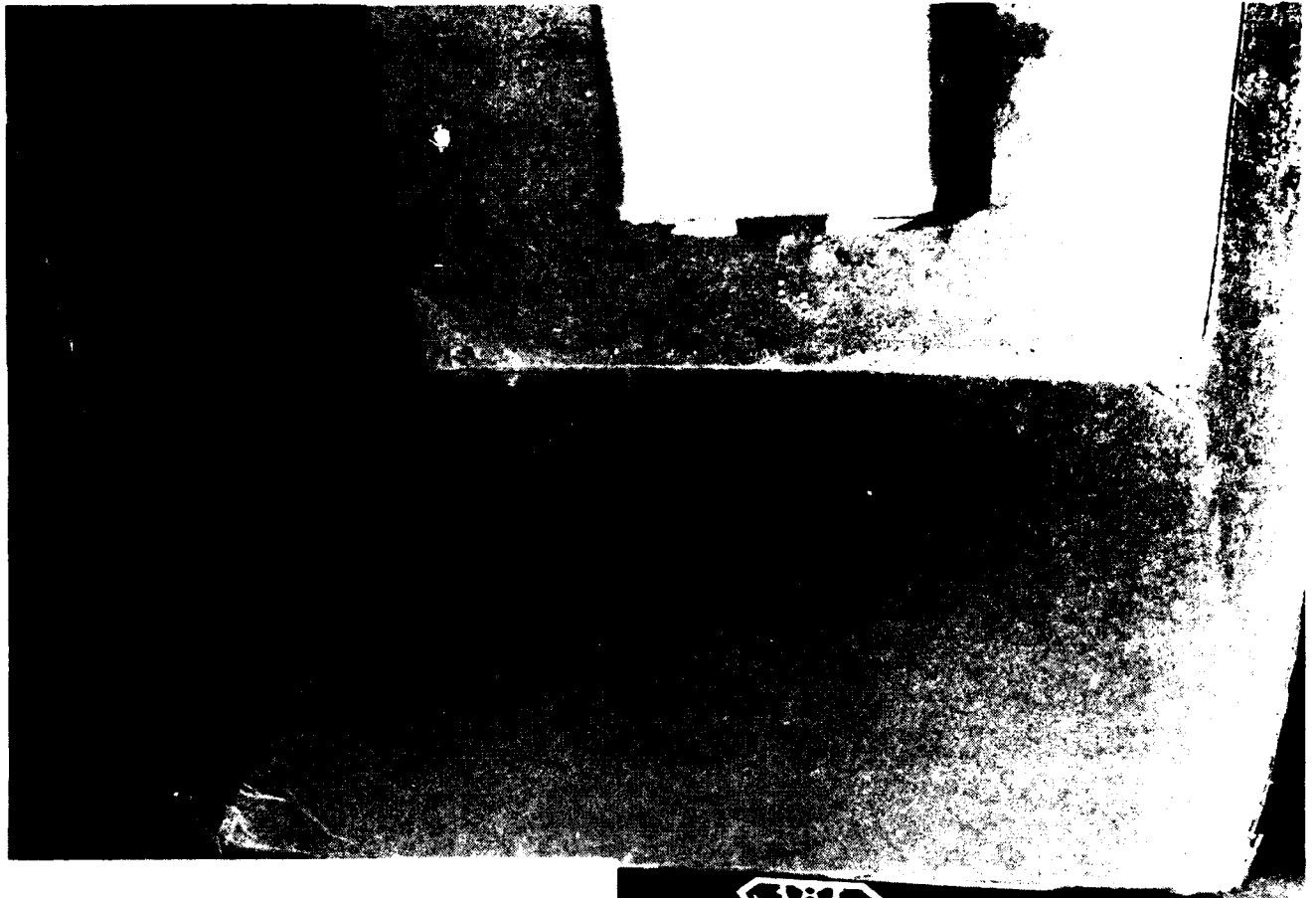
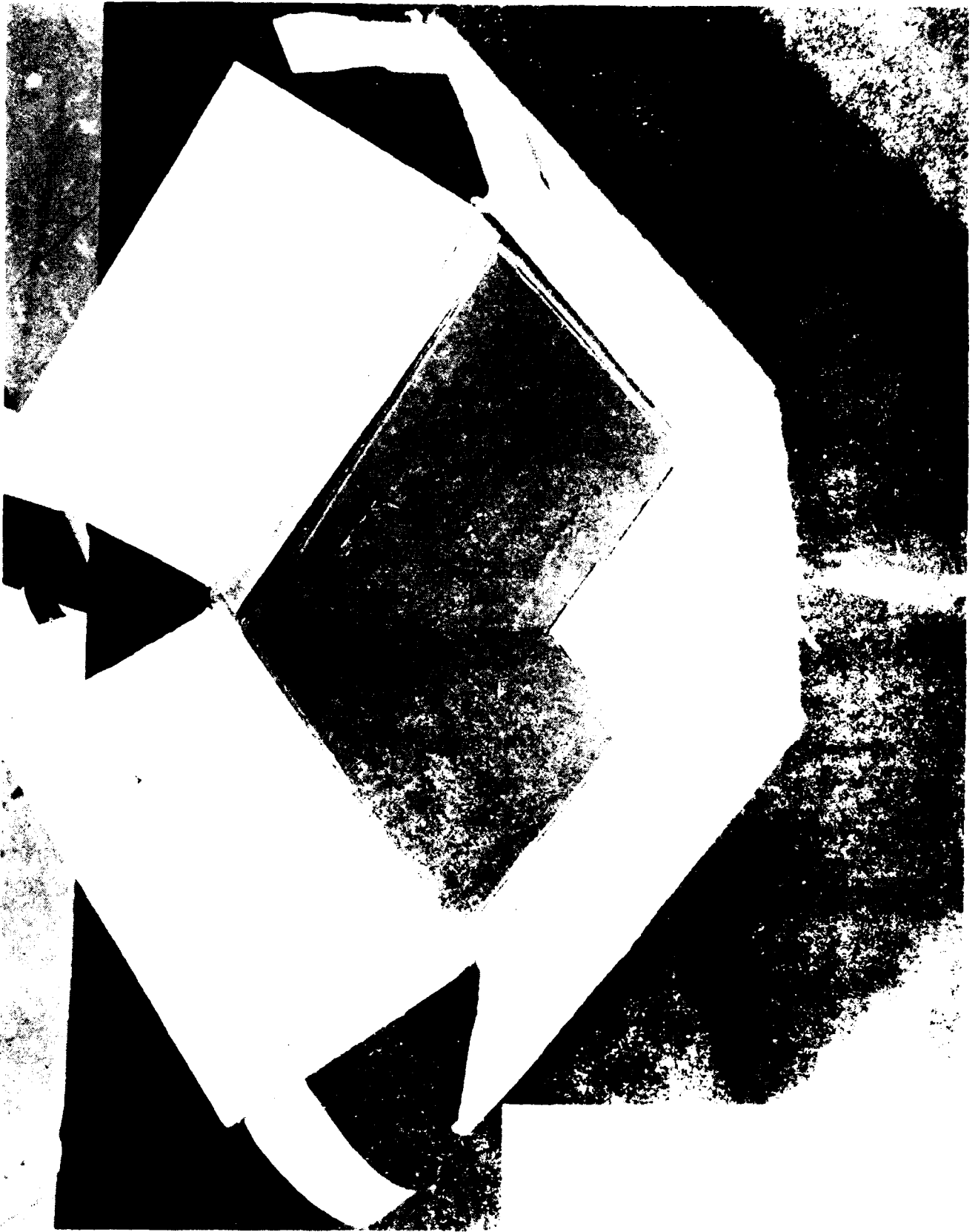

FIGURE 2
REAR VIEW OF COVER







PROCEDURE: A DATE: 10 Nov 86
 DROP HEIGHT: 27"
 PACK PROTOTYPE: 8 x 8 x 8 PRI
 22 x 22 x 22 FTC
 8 x 8 x 6 Grade A Cushions
 DUMMY LOAD: Gyro & PRI Ctnr
 WEIGHT: .98 + 5.82 = 6.8

PROCEDURE: A DATE: 10 Nov 86
 DROP HEIGHT: 27"
 PACK PROTOTYPE: 8 x 8 x 8 PRI
 22 x 22 x 22 FTC
 8 x 8 x 6 Grade A Cushions
 DUMMY LOAD: Gyro & PRI Ctnr
 WEIGHT: 4.1 + 5.6 = 9.7

ORIENTATION {FLAT (a), EDGE (a, b), CORNER (a, b, c)}

TEST 1 SS = .106								TEST 2 SS = .152								
a	b	c	X	Y	Z	R		a	b	c	X	Y	Z	R		
3			11	2	0	11.2	Side Avg 10.2	1	3		4	13	1	13.6	Side Avg 13.3	
1			11	1	6	12.6		2	1		1	15	1	15.1		
2			4	3	10	11.2		3	2		1	1	15	15.1		
4			2	2	8	8.5		4	4		1	1	12	12.1		
5			1	8	2	8.3		5	5		11	1	3	11.4		
6			4	8	2	9.1		6	6		12	2	2	12.3		
1	2		3	2	8	8.8	Edge Avg 9.6	7	1	2	1	4	5	6.5	Edge Avg 7.6	
3	4		5	2	9	10.5		8	3	4	1	6	6	8.5		
1	4		8	1	5	9.5		9	1	4	1	4	6	7.3		
2	3		9	2	7	11.6		10	2	3	1	6	6	8.5		
3	5		6	9	1	10.9		11	3	5	5	6	3	8.4		
1	6		4	5	3	7.1		12	1	6	6	4	1	7.3		
1	5		5	5	1	7.1		13	1	5	8	2	1	8.3		
3	6		8	5	1	9.5		14	3	6	6	5	1	7.9		
2	5		1	9	5	10.3		15	2	5	5	2	5	7.7		
4	6		1	7	7	9.9		16	4	6	6	1	5	7.9		
4	5		2	5	8	9.6		17	4	5	5	1	4	6.5		
2	6		4	4	3	7.8		18	2	6	5	1	4	6.5		
1	4	5	7	3	7	10.3	Corner Avg 9.9	19	1	4	5	8	2	7	10.8	Corner Avg 8.8
2	3	6	9	5	4	11.0		20	2	3	6	8	8	4	12.0	
1	2	6	1	6	7	9.3		21	1	2	6	7	3	6	9.7	
3	4	5	4	5	9	11.0		22	3	4	5	5	6	2	6.5	
1	4	6	6	6	4	9.4		23	1	4	6	5	2	5	7.4	
2	3	5	7	8	4	11.4		24	2	3	5	5	5	3	7.7	
3	4	6	5	6	5	9.3		25	3	4	6	6	5	4	8.8	
1	2	5	2	5	5	7.3		26	1	2	5	4	2	6	7.5	

PROJECT NUMBER: 85-P-146 TESTED BY: LA Wood
 MODEL NUMBER: CW-78
 COMMENTS: Same pack tested for 1 lb and 4.1 lb load
 PRI ctnr contains 4.2 lbs aluminum ballast
 Cushions have MIL-B-131 covers
 NOTE: Actual Wt range = 6.8 # to 9.7 #

BTMS 101C: METHOD 5007

DROP TEST (FREE FALL) WORKSHEET

PROCEDURE: A DATE: 10 Nov 86
 DROP HEIGHT: 27"
 PACK PROTOTYPE: 10 x 10 x 10 PRI
 23 x 23 x 23 FTC
 8 x 8 x 6 Grade A Cushions
 DUMMY LOAD: Gyro + PRI Ctnr
 WEIGHT: 4.1 + 3.5 = 7.6 Lbs

PROCEDURE: A DATE: 10 Nov 86
 DROP HEIGHT: 27"
 PACK PROTOTYPE: 10 x 10 x 10 PRI
 23 x 23 x 23 FTC
 8 x 8 x 6 Grade A Cushions
 DUMMY LOAD: Gyro + PRI Ctnr
 WEIGHT: 10.1 + 3.5 = 13.6 Lbs

ORIENTATION: [FLAT (a), EDGE (a, b), CORNER (a, b, c)]

TEST 1 SS = .119								TEST 2 SS = .21								
a	b	c	X	Y	Z	R		a	b	c	X	Y	Z	R		
3			1	11	3	11.4	Side Avg 10.5	1	3		2	14	2	14.3	Side Avg 12.3	
1			3	12	0	12.4		2	1		1	11	1	11.1		
2			8	5	2	9.6		3	2		12	3	1	12.4		
4			9	1	4	9.9		4	4		11	2	1	11.2		
5			3	2	8	8.8		5	5		4	1	10	10.8		
6			1	4	10	10.8		6	6		1	2	14	14.2		
1	2		10	9	0	13.4	Edge Avg 12.0	7	1	2	7	4	1	8.1	Edge Avg 8.0	
3	4		8	8	3	11.7		8	3	4	5	5	1	7.1		
1	4		6	10	1	11.7		9	1	4	5	5	1	7.1		
2	3		9	8	0	12.0		10	2	3	5	6	2	8.1		
3	5		3	9	8	12.4		11	3	5	2	5	4	6.7		
1	6		5	9	8	13.0		12	1	6	2	6	5	8.1		
1	5		1	11	7	13.1		13	1	5	3	5	6	8.4		
3	6		2	8	9	12.2		14	3	6	2	5	6	8.1		
2	5		9	2	6	11.0		15	2	5	6	3	4	7.8		
4	6		8	2	9	12.2		16	4	6	4	1	5	6.5		
4	5		5	4	8	10.2		17	4	5	7	1	8	10.7		
2	6		7	4	8	11.3		18	2	6	6	4	5	8.8		
1	4	5	8	8	7	13.3	Corner Avg 12.7	19	1	4	5	3	1	5	5.9	Corner Avg 6.2
2	3	6	8	7	9	13.9		20	2	3	6	4	2	5	6.7	
1	2	6	7	9	6	12.9		21	1	2	6	5	2	5	7.3	
3	4	5	5	7	7	11.1		22	3	4	5	5	3	4	7.1	
1	4	6	4	8	8	12.0		23	1	4	6	4	2	4	6.0	
2	3	5	8	6	7	12.2		24	2	3	5	4	3	2	5.4	
3	4	6	5	8	7	11.7		25	3	4	6	4	2	3	5.4	
1	2	5	9	9	7	14.5		26	1	2	5	2	5	1	5.5	

OBJECT: 85-P-146
 IDENT: CW-78

TESTED BY: LA Wood

NOTE: Same pack tested for 4 Lb and 10.1 Lb load
 PRI ctnr contains 2 Lb plywood ballast
 Cushions have MIL-B-131 covers
 NOTE: Actual Wt range = 7.6 # to 13.6 #

SPECIAL PACKAGING INSTRUCTION

CODE ID
97151

SPI NO. (TPO)
TBD2

ITEM NOMENCLATURE
CONTAINER, SHIPPING, 15G, 1-4 LB.NET.

SHEET 2 OF 3

Cushioning Detail

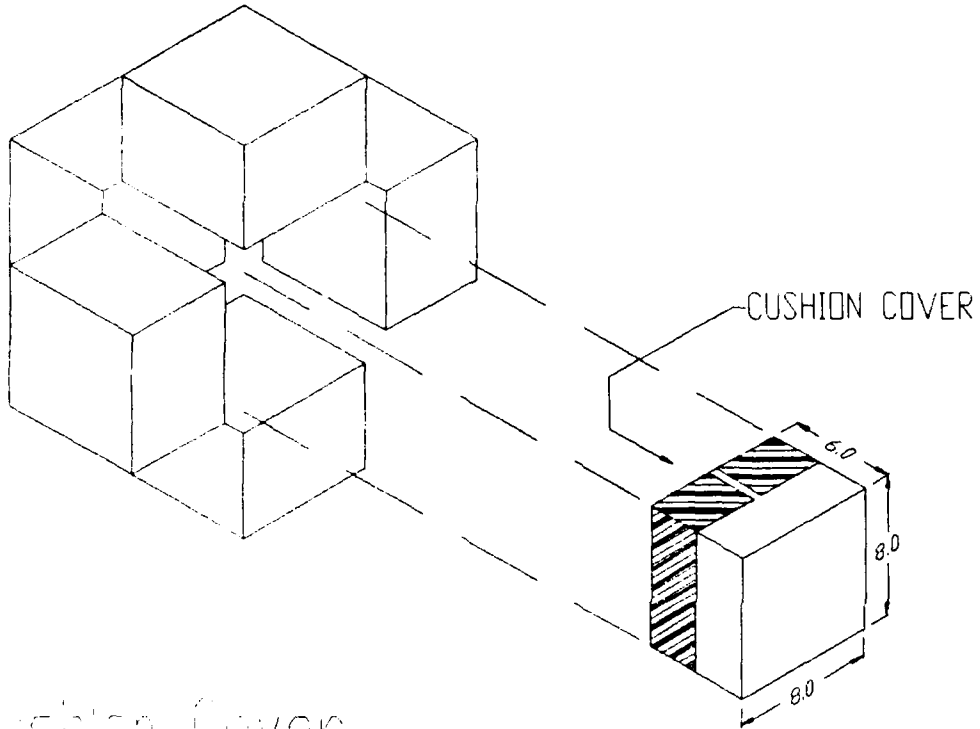

Cushion Cover
Flat Pattern

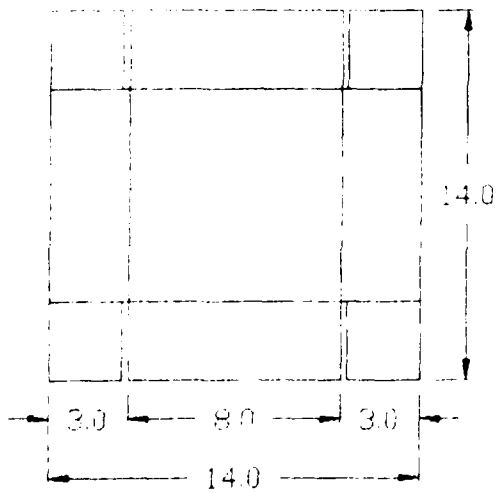

SPECIAL PACKAGING INSTRUCTION	CODE ID 97151	SPI NO. (TPD) TBD2
ITEM NOMENCLATURE CONTAINER, SHIPPING, 15G 1-4 LB.NET.		SHEET 3 OF 3

Primary Container Detail

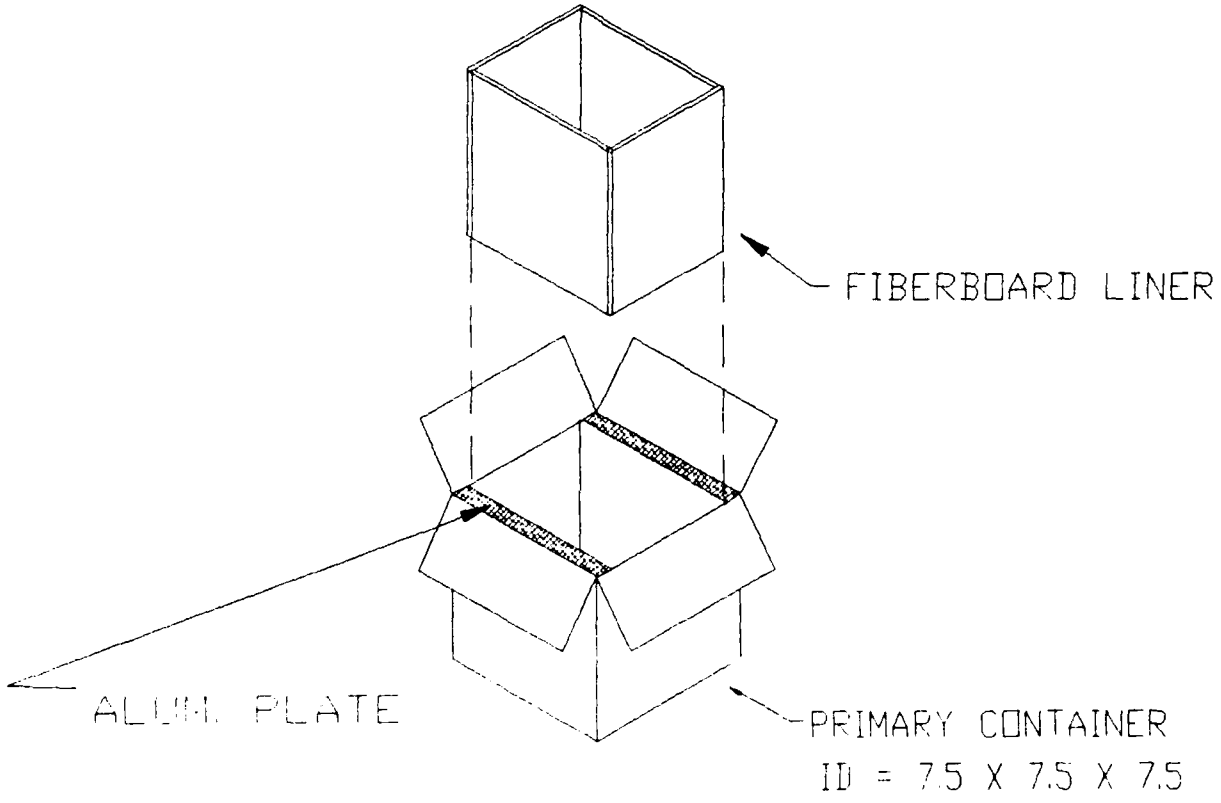

Container Layout

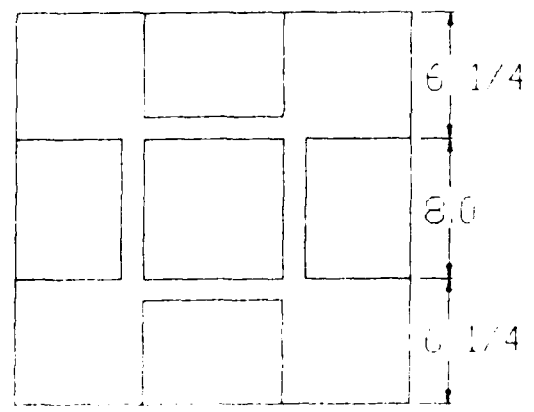

SPECIAL PACKAGING INSTRUCTION

CODE ID
97151

SPI NO. (TPD)
TBD1

ITEM NOMENCLATURE
CONTAINER, SHIPPING, 15G, 4-10 LB NET

SHEET 2 OF 3

Cushioning Detail

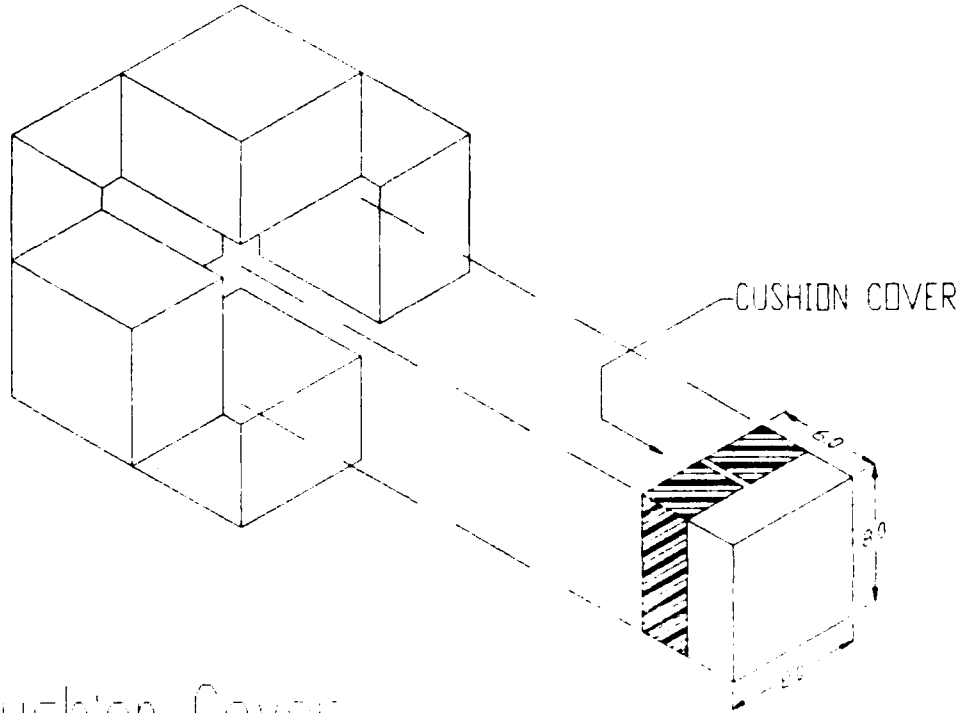

Cushion Cover
Flat Pattern

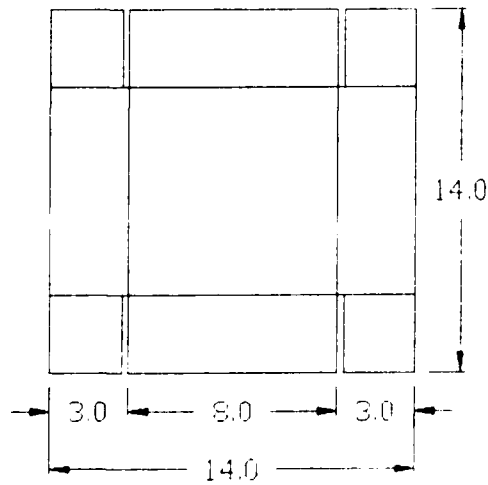

SPECIAL PACKAGING INSTRUCTION

CODE ID
97151

SPI NO. (TPD)
TBD1

ITEM NOMENCLATURE
CONTAINER, SHIPPING, 15G, 4-10 LB.NET

SHEET 3 OF 3

Primary Container Detail

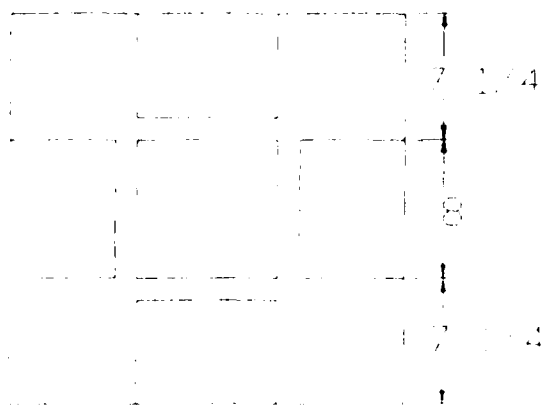
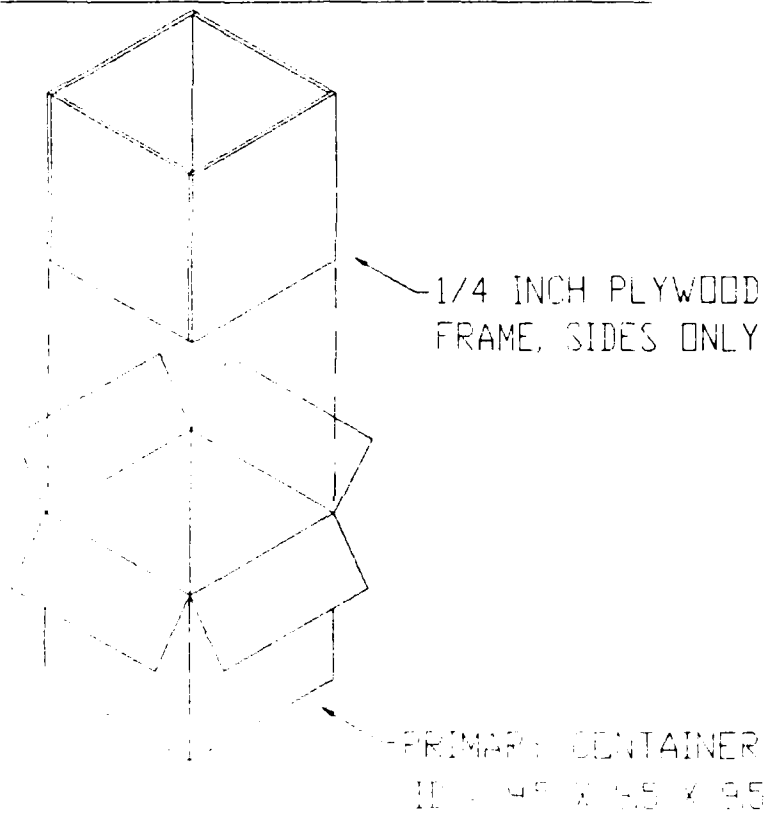

AD-A182103

SECURITY CLASSIFICATION OF THIS PAGE

REPORT DOCUMENTATION PAGE

1a. REPORT SECURITY CLASSIFICATION UNCLASSIFIED		1b. RESTRICTIVE MARKINGS UNLIMITED DISTRIBUTION	
2a. SECURITY CLASSIFICATION AUTHORITY N/A		3. DISTRIBUTION/AVAILABILITY OF REPORT APPROVED FOR PUBLIC RELEASE DISTRIBUTION UNLIMITED	
2b. DECLASSIFICATION/DOWNGRADING SCHEDULE N/A			
4. PERFORMING ORGANIZATION REPORT NUMBER(S) DSTZT Report No. 87-R-02		5. MONITORING ORGANIZATION REPORT NUMBER(S) DSTZT Report No: 87-R-02	
6a. NAME OF PERFORMING ORGANIZATION Air Force Packaging Evaluation Agency	6b. OFFICE SYMBOL <i>(If applicable)</i> HQ AFLC/DSTZT	7a. NAME OF MONITORING ORGANIZATION Air Force Packaging Evaluation Agency	
6c. ADDRESS (City, State and ZIP Code) HQ AFLC/DSTZT Wright-Patterson AFB OH 4533-5999		7b. ADDRESS (City, State and ZIP Code) HQ AFLC/DSTZT Wright-Patterson AFB OH 45433-5999	
8a. NAME OF FUNDING/SPONSORING ORGANIZATION Air Force Packaging Evaluation Agency	8b. OFFICE SYMBOL <i>(If applicable)</i> HQ AFLC/DSTZT	9. PROCUREMENT INSTRUMENT IDENTIFICATION NUMBER N/A	
8c. ADDRESS (City, State and ZIP Code) HQ AFLC/DSTZT Wright-Patterson AFB OH 45433-5999		10. SOURCE OF FUNDING NOS	
		PROGRAM ELEMENT NO.	PROJECT NO.
			85-P-146
			85-P-146
11. TITLE (Include Security Classification) Development of Multi-purpose Low Fragility Container System for Small, Lightweight Items		TASK NO.	WORK UNIT NO.
12. PERSONAL AUTHOR(S) WOOD, LARRY A.			
13a. TYPE OF REPORT FINAL	13b. TIME COVERED FROM Apr 85 TO Dec 86	14. DATE OF REPORT (Yr., Mo., Day) December 1986	15. PAGE COUNT
16. SUPPLEMENTARY NOTATION			
17. COSATI CODES		18. SUBJECT TERMS (Continue on reverse if necessary and identify by block number)	
FIELD	GROUP	SUB GR	
		Packaging, Low Fragility, Multi-purpose	
19. ABSTRACT (Continue on reverse if necessary and identify by block number)			
<p>The objective of this project was to develop a multi-purpose pack to provide a protection level of at least 15Gs for small, shock sensitive, lightweight items (such as gyros and electronic components) within the weight range of 1 to 5 pounds. The scope of this effort was later expanded to include items up to 10 pounds using a second pack design.</p>			
20. DISTRIBUTION/AVAILABILITY OF ABSTRACT UNCLASSIFIED/UNLIMITED <input checked="" type="checkbox"/> SAME AS RPT <input type="checkbox"/> DTIC USERS <input type="checkbox"/>		21. ABSTRACT SECURITY CLASSIFICATION	
22a. NAME OF RESPONSIBLE INDIVIDUAL LARRY A. WOOD		22b. TELEPHONE NUMBER <i>(Include Area Code)</i> (513) 257-4519	22c. OFFICE SYMBOL HQ AFLC/DSTZT

DISTRIBUTION LIST

DTIC/FDAC Cameron Station Alexandria VA 22304-6145	12	Commander Naval Supply Systems Command ATTN: N. Karl (SUP 0611F) Washington DC 20376-5000	1
HQ AFLC/DSTZ Library Wright-Patterson AFB OH 45433-5999	20	Commander Naval Air Systems Command ATTN: E. Panigot (AIR 41212A) Washington DC 20361	1
HQ USAF/LETT Washington DC 20330	1	Commander Space and Naval Warfare Systems ATTN: C. Corbe (Code 8218) Washington DC 20360	1
OO-ALC/DST Hill AFB UT 84406-5999	1	Commander Naval Facilities Engineering Hoffman Bldg. #2, Room 12S21 ATTN: C. Manwarring (FAC 0644) Alexandria VA 22332	1
OC-ALC/DST Tinker AFB OK 73145-5999	1	Commanding Officer Naval Construction Battalion ATTN: K. Pollock (Code 15611K) Port Hueneme CA 93043	1
SM-ALC/DST McClellan AFB CA 95652	1	Commander Naval Sea Systems Command ATTN: G. Mustin (SEA 6G53) Washington DC 20362	1
SA-ALC/DST Kelly AFB TX 78241-5999	1	Commander Naval Sea Systems Command ATTN: F. Basford (SEA 05M3) Washington DC 20362	1
WR-ALC/DST Robins AFB GA 31098-5999	1	Commanding Officer Naval Aviation Supply Office 700 Robbins Avenue ATTN: J. Yannello (Code EPP-A) Philadelphia PA 19111-5098	1
ASD/AWL/ALXP Wright-Patterson AFB OH 45433-6503	3	Commanding Officer Navy Ships Parts Control Center PO Box 2020 ATTN: F. Sechrist (Code 0541) Mechanicsburg PA 17055-0788	1
DLSIE/AMXMC-D USA Logistics Management Center Fort Lee VA 23801-6043	1		
US AMCPSCC/SDSTO-T Tobyhanna PA 18466	1		
US Army Natick Laboratory ATTN: STRNC-ES Natick MA 01760	1		
Commanding Officer Naval Air Engineering Center ATTN: F. Magnifico (SESD Code 9321) Lakehurst NJ 08733-5100	1		

DISTRIBUTION LIST (Con't)

AD/YNP Eglin AFB FL 32542	1	HQ DLA-OWO Cameron Station Alexandria VA 22304-6145	1
ASO/TEP-A 4030 700 Robbins Avenue Philadelphia PA 19111	1	US Army Armament Munitions and Chemical Command ATTN: SMCAR-AED	1
GSA, Office of Engineering Management Packaging Division Washington DC 20406	1	Dover NJ 07801-5001 Commanding Officer Naval Weapon Station, Earle ATTN: NWHC 80A	1
HQ AFLC/LGT Andrews AFB DC 20334		Coltsneck NJ 07722	

END

8-87

DTIC