

Technical Report  
779

# A Dual-Frequency Feed with Electronic Tracking Capability

J.C. Lee

22 May 1987

---

**Lincoln Laboratory**

MASSACHUSETTS INSTITUTE OF TECHNOLOGY

*LEXINGTON, MASSACHUSETTS*



---

Prepared for the Department of the Army  
under Electronic Systems Division Contract F19628-85-C-0002.

Approved for public release; distribution unlimited.

ADA 182213

The work reported in this document was performed at Lincoln Laboratory, a center for research operated by Massachusetts Institute of Technology. This work was sponsored by the Department of the Army, USASATCOMA, under Air Force Contract F19628-85-C-0002.

This report may be reproduced to satisfy needs of U.S. Government agencies.

The views and conclusions contained in this document are those of the contractor and should not be interpreted as necessarily representing the official policies, either expressed or implied, of the United States Government.

The ESD Public Affairs Office has reviewed this report, and it is releasable to the National Technical Information Service, where it will be available to the general public, including foreign nationals.

This technical report has been reviewed and is approved for publication.

FOR THE COMMANDER

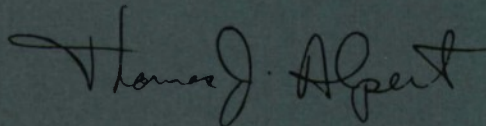
A handwritten signature in black ink that reads "Thomas J. Alpert". The signature is written in a cursive style with a large initial 'T' and 'A'.

Thomas J. Alpert, Major, USAF  
Chief, ESD Lincoln Laboratory Project Office

Non-Lincoln Recipients

**PLEASE DO NOT RETURN**

Permission is given to destroy this document  
when it is no longer needed.

MASSACHUSETTS INSTITUTE OF TECHNOLOGY  
LINCOLN LABORATORY

**A DUAL-FREQUENCY FEED  
WITH ELECTRONIC TRACKING CAPABILITY**

*J.C. LEE*  
*Group 61*

TECHNICAL REPORT 779

22 MAY 1987

Approved for public release; distribution unlimited.

LEXINGTON

MASSACHUSETTS

## **ABSTRACT**

A dual-frequency Q-/K-band circularly polarized feed with electronic tracking capability was developed. Four circumferentially located, externally coupled, diode controlled, resonant cavities were used at the horn throat to produce phase-center lateral movement. When used to feed a 24-in-diam. offset paraboloidal reflector, an average beam squint from boresight of 10 percent of the 3-dB beamwidth was obtained over a 5-percent bandwidth.

## TABLE OF CONTENTS

Abstract	iii
List of Illustrations	vii
I. INTRODUCTION	1
II. PRELIMINARY INVESTIGATION	5
III. MECHANICALLY TUNED CAVITY TRACKING FEED	7
IV. ELECTRONICALLY TUNED CAVITY TRACKING FEED	9
V. DISCUSSION AND CONCLUSIONS	21
Acknowledgments	23
References	23

## LIST OF ILLUSTRATIONS

Figure No.		Page
1	Dual-Frequency Feed Without Electronic Tracking	1
2	Dual-Frequency Feed with Circumferential Error-Signal Probes	2
3	Dual-Frequency Feed with Coaxial Error-Signal Probe	3
4	Dual-Frequency Feed with Externally Coupled Resonant Cavities	3
5	Photograph of Two-Times Scaled Feed with Four Mechanical Switches	8
6	Diode Switch Components in Curved Waveguide Fixture	9
7	Typical Transmission and Reflection Characteristics of Diode Switch: (a) Forward Biased; (b) Reverse Biased	10
8	Typical Reflection Phase Variation as Diode Bias Condition Changes	11
9	Details of Diode Location in the Dual-Band Tracking Feed	12
10	Coupling Characteristics of Coaxial Waveguide to Side Cavity	12
11	The Tracking Feed Horn and the Transition Fixtures	13
12	Tracking Feed with Reflector Antenna on Measuring Pedestal	13
13	Measured Beam-Loping Patterns at 20.4 GHz	14
14	Measured Beam-Loping Patterns at 20.6 GHz	16
15	Measured Beam-Loping Patterns at 20.9 GHz	17
16	Measured Beam-Loping Patterns at 21.2 GHz	18
17	Measured Beam-Loping Patterns at 21.4 GHz	19

# A DUAL-FREQUENCY FEED WITH ELECTRONIC TRACKING CAPABILITY

## I. INTRODUCTION

A compact dual-frequency feed without electronic tracking was recently described.<sup>1</sup> Figure 1 gives a detailed sketch of that feed. The center frequencies of the two bands are 44.5 and 20.7 GHz, respectively, and the bandwidth for each is about 5 percent. An antenna using this feed can autotrack by mechanically stepping the whole antenna assembly or by conically scanning the feed. Mechanical maneuvering of this nature requires relatively high power consumption and also suffers the limitations of slow response time and short reliable life. In addition, the beams in both frequency bands scan, whereas generally it is desired to leave one beam fixed (the transmit beam) and only scan the receiving beam.

Ways to add an electronic tracking capability to the feed, requiring no mechanical motion, were studied and a dual-frequency Q-/K-band circularly polarized feed for an offset reflector with electronic tracking capability in the receive band only (K-band) has been developed. The desired beam squint from boresight is 6 to 12 percent of the 3-dB beamwidth or, using a 24-in-diam. reflector,  $0.1^\circ$  to  $0.2^\circ$ .

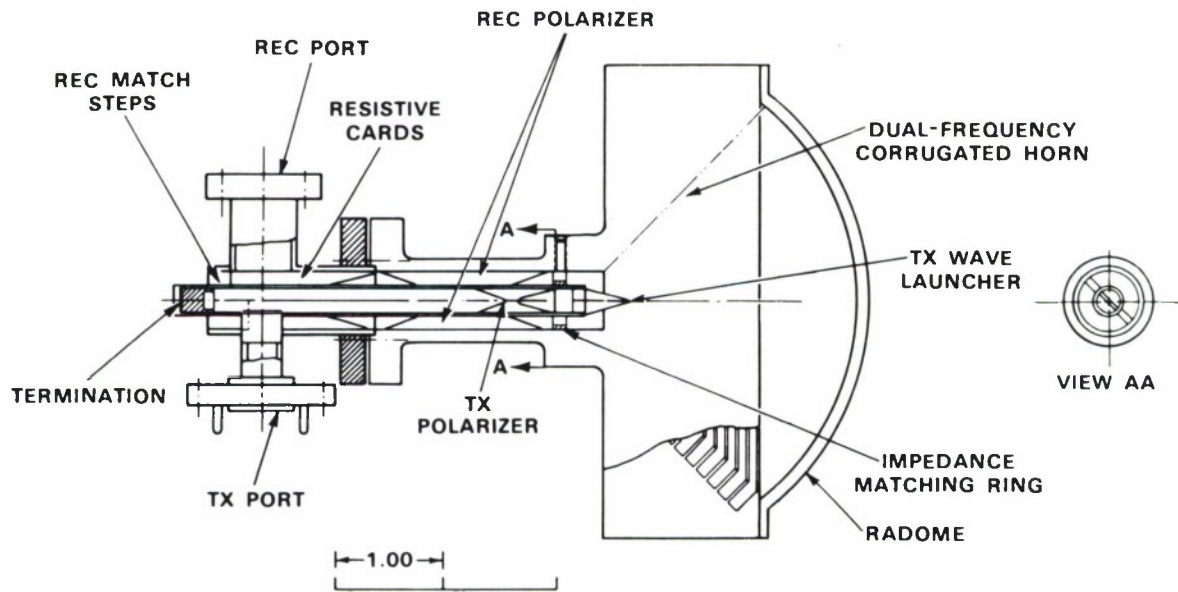

Figure 1. Dual-frequency feed without electronic tracking.

79451-1

Conventional monopulse tracking feeds using 4- or 5-horn clusters combined with hybrids (Reference 2) were excluded early in the study because of this design's inherently complicated structure. Various degrees of simplification in tracking feed design have been devised,<sup>3,4</sup> and we have experimentally investigated three different approaches in order to further simplify the design for the case of single-band tracking in a dual-band feed design. The first approach uses four circumferentially equally spaced perpendicular probes at the throat of a corrugated horn (Figure 2); the second uses a single coaxial probe which protruded from the Q-band circular waveguide

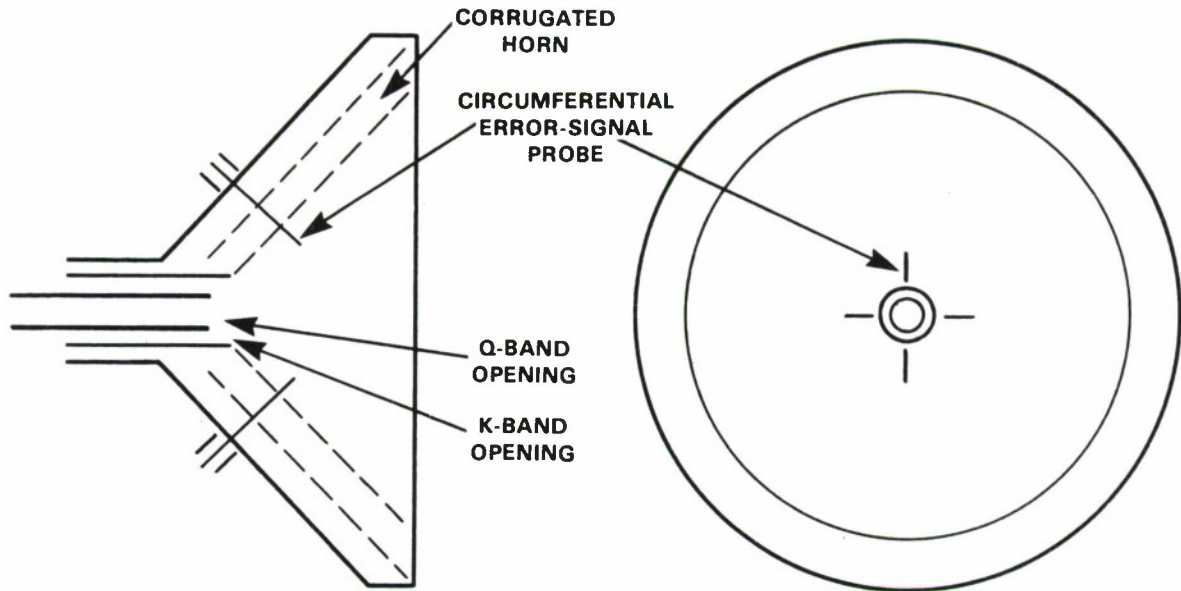

Figure 2. Dual-frequency feed with circumferential error-signal probes.

opening at the throat of the feed horn and coupled to the TM<sub>01</sub> mode (Figure 3); and the third uses four circumferentially located, externally coupled switchable resonant cavities to produce lateral motion of the K-band phase center (Figure 4). For the first and second approaches, additional TEM hybrids, couplers, and switches are needed to form a feeding network.

Results of the general investigation, and particularly the development of the third approach, are presented in this report.

79451-3

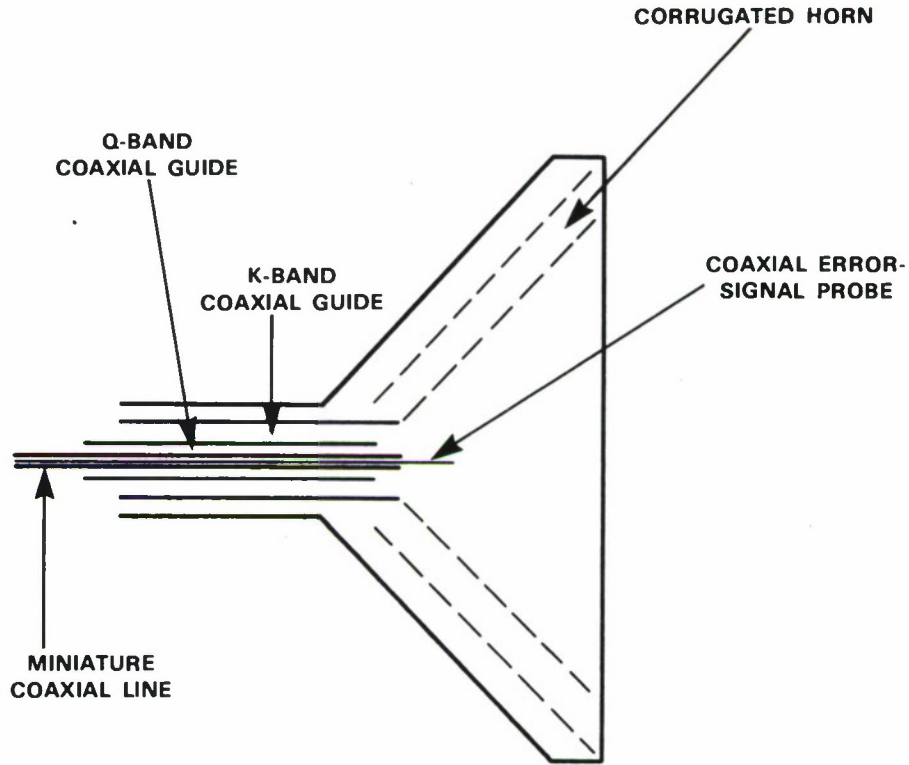

Figure 3. Dual-frequency feed with coaxial error-signal probe.

79451-4

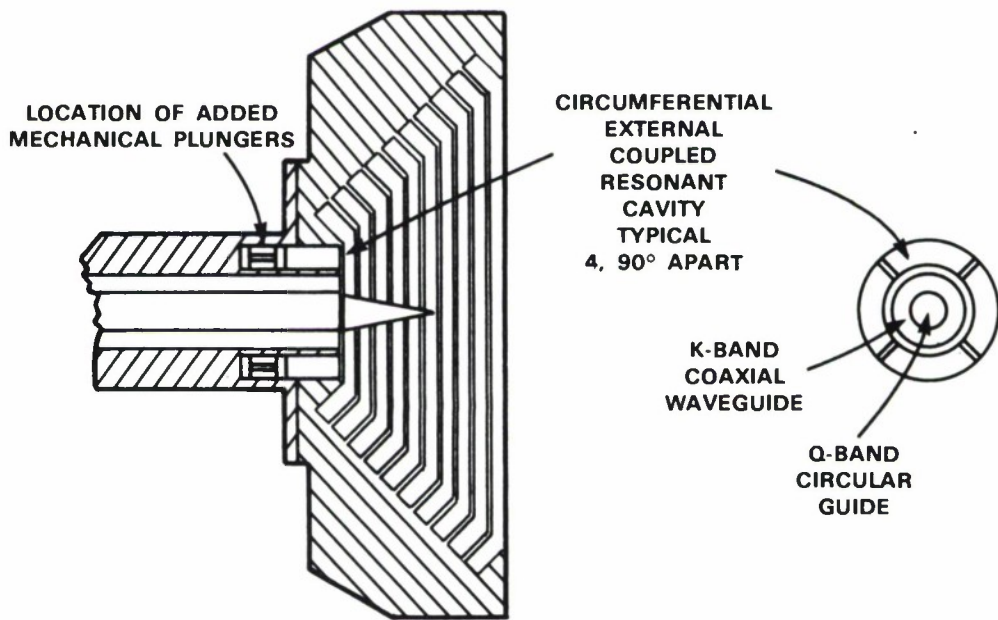

Figure 4. Dual-frequency feed with externally coupled resonant cavities.

## II. PRELIMINARY INVESTIGATION

In the first approach using four circumferentially spaced perpendicular probes, both TE<sub>21</sub> and TM<sub>01</sub> modes were excited, causing the radiation pattern to be frequency sensitive and the beam squint to be asymmetric about the antenna boresight. This approach was quickly abandoned.

In the second approach using a single coaxial probe protruding from the Q-band circular guide opening, only the TM<sub>01</sub> mode was excited at K-band, resulting in very symmetric error-signal patterns as desired. The effects of the probe on overall K-band performance (i.e., gain, beamwidth, etc.) were negligible. The presence of the probe in the open end of the Q-band circular waveguide, however, adversely affected the Q-band primary radiation pattern. Presumably, the length of the axial probe could have been shortened to minimize this adverse effect, but such a change would have made the probe less effective in producing adequate beam squint. Detailed consideration of mechanical tolerances involving an odd-size small coaxial line in the Q-band circular guide also discouraged further consideration of this approach.

The third approach is similar in principle to a single frequency-band tracking feed used on the LES-8/9 crosslink antenna.<sup>5</sup> It involves arranging four fringe-field-coupled cavities around the K-band coaxial waveguide opening inside the corrugated horn. The electrical length of these cavities is varied by switches to create open- and short-circuit conditions at each cavity opening. Since the feed is circularly polarized, the antenna pointing error can be readily obtained from the beam-lobing information.<sup>6</sup> Preliminary tests showed encouraging results.

### III. MECHANICALLY TUNED CAVITY TRACKING FEED

A two-times scaled feed was constructed with four quarter-wave cavities of curved cross section, each one-quarter of a circular coaxial waveguide to fit around the circular coaxial 20-GHz waveguide opening at the throat of the corrugated horn. The length of these cavities was adjustable by means of four mechanical short-circuit plungers (Figures 4 and 5). Preliminary measured results of amplitude and phase patterns were promising. Good primary amplitude and phase patterns were obtained in both the scaled K- and X-bands (corresponding to the original Q- and K-bands, respectively).

For the feed alone, the phase-center transversal displacements when the two pairs of adjacent cavities were alternately short- and open-circuited manually was measurable at X-band but remained negligible at K-band as desired. The measured phase-center movement data together with "calculated" beam squint based on a 24-in-diam. reflector are given in the table below. Beam-squint parameters for the LES-8/9 crosslink antenna also are included for comparison. (The error slope is defined as  $dV/d\theta$ , where  $V$  is error voltage normalized to the peak voltage, and  $\theta$  is the beam-squint angle normalized to the 3-dB beamwidth.)

Frequency (GHz)	Phase-Center Transversal Displacement (in)	Scaled Frequency (GHz)	Scaled Phase-Center Displacement (in)	Beam-width (deg)	Beam Squint (deg)	Cross-over (dB)	Error Slope
9.34	0.12	20.2	0.028	1.67	0.11	0.05	0.25
9.66	0.16	20.7	0.038		0.14	0.08	0.38
9.89	0.20	21.2	0.047		0.18	0.12	0.41
LES-8/9		36.94		1.13	0.085	0.07	0.32

The reflector used with the feed in this development was an offset reflector with a projected circular aperture diameter of 24 in. The reflector diameter for the LES-8/9 crosslink is 18 in. The corresponding 3-dB beamwidths are  $1.67^\circ$  and  $1.13^\circ$ , respectively. From the table, we see that the phase-center transversal displacements are sufficient to cause a beam crossover level about 0.1 dB, comparable to that of the LES-8/9 crosslink antenna. We note that the operating bandwidth of LES-8/9 is 0.16 percent while the present bandwidth is 5 percent — a 30-fold increase.

A full-scale mechanically tuned cavity feed horn also was made. With the reflector described in the preceding paragraph, the actual beam squints were directly measured by comparing the secondary patterns. These results agreed well with the "calculated" beam squints.

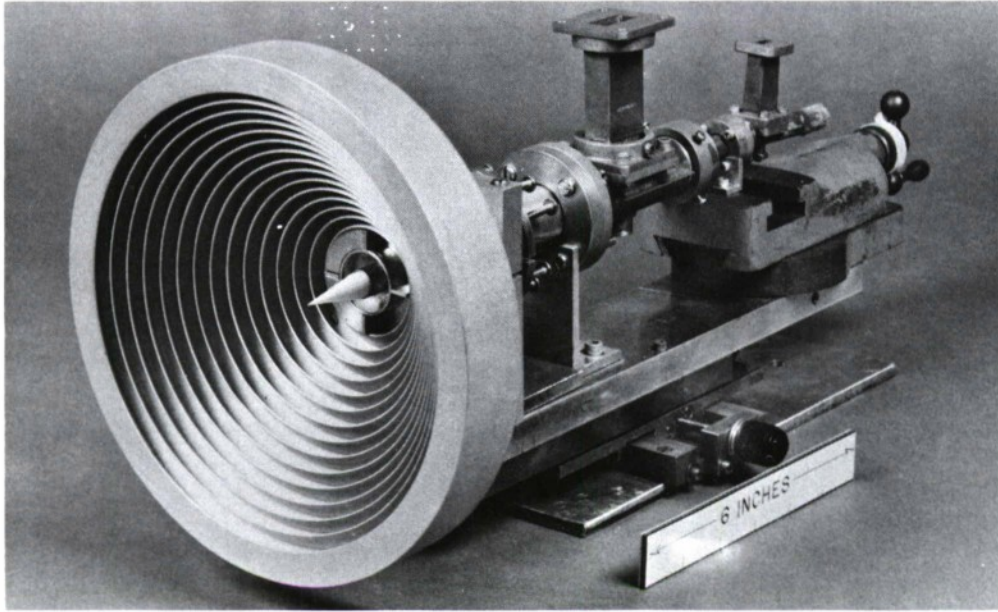

*Figure 5. Photograph of two-times scaled feed with four mechanical switches.*

#### IV. ELECTRONICALLY TUNED CAVITY TRACKING FEED

Before the electronically tuned cavity tracking feed could be built, it was necessary to develop the electronic switches. For compact size and broad-band operation, diodes were chosen instead of ferrites as the switching elements. Although beam-lead PIN diodes are considered more electrically suitable for high-frequency K-band switching applications, more conventional diode packages were used for ease of handling. A few discrete, glass-packaged miniature PIN diodes with low RF loss and low reactance were ordered from diode manufacturers. Switching times of these diodes are on the order of nanoseconds. Each of the diodes was tested in a K-band diode test fixture across the curved waveguide cross section as a switch (Figure 6).

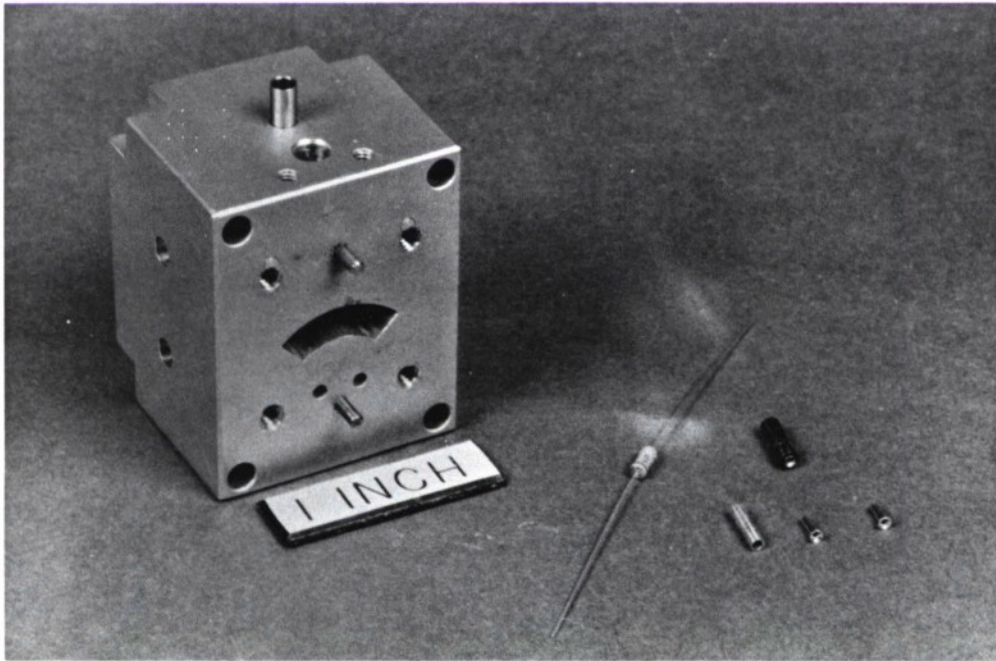

Figure 6. Diode switch components in curved waveguide fixture.

The amplitude and phase characteristics of each diode in both the transmission and reflection state were evaluated. Typical transmission and reflection characteristics of the diodes (MA-4P104-54) selected for use in the feed with forward- and reverse-bias conditions are given in Figure 7(a) and (b). With forward bias, the transmission-mode insertion loss is less than 0.4 dB and the return loss is less than 14 dB. With reverse bias, the reflection-mode insertion loss is more than 11 dB and the return loss is less than 1 dB.

With a shorting plate in place at the appropriate location at the rear of the quarter-wave cavity, typical reflection phase change of a diode-loaded quarter-wave cavity is given in Figure 8.

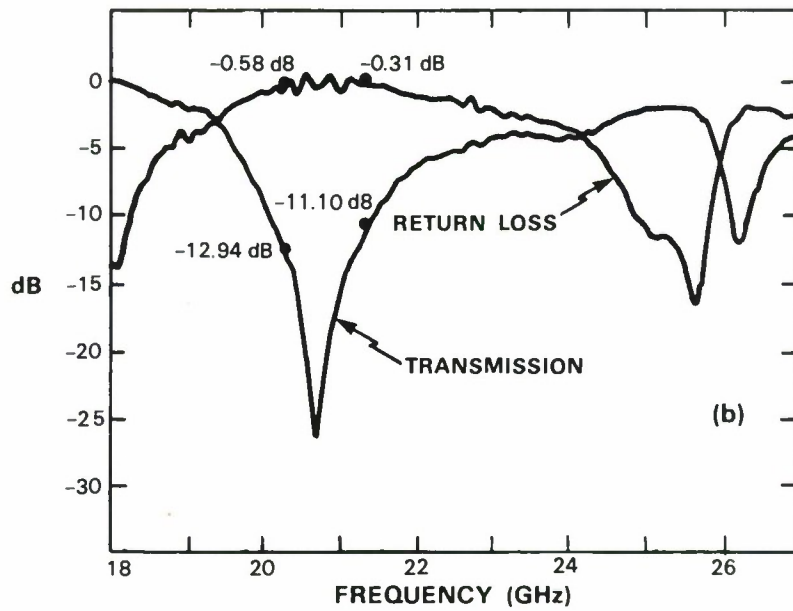
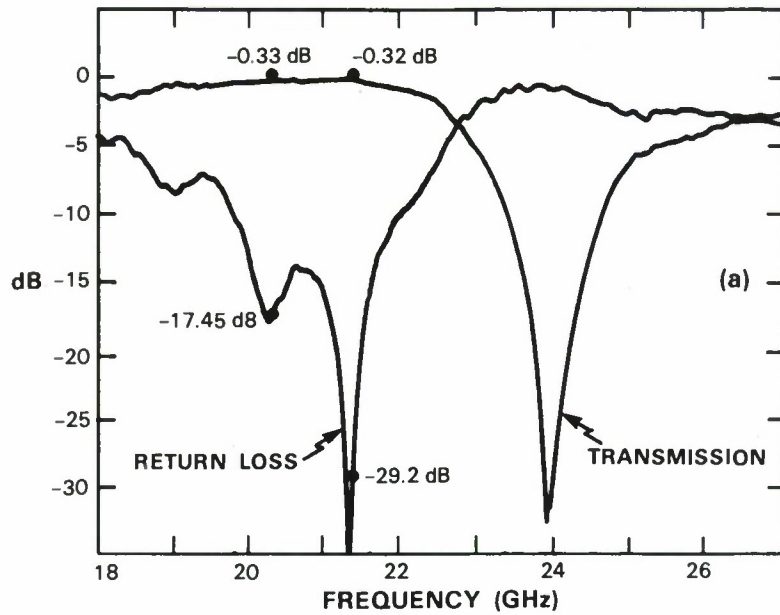

Figure 7. Typical transmission and reflection characteristics of diode switch: (a) forward biased; (b) reverse biased.

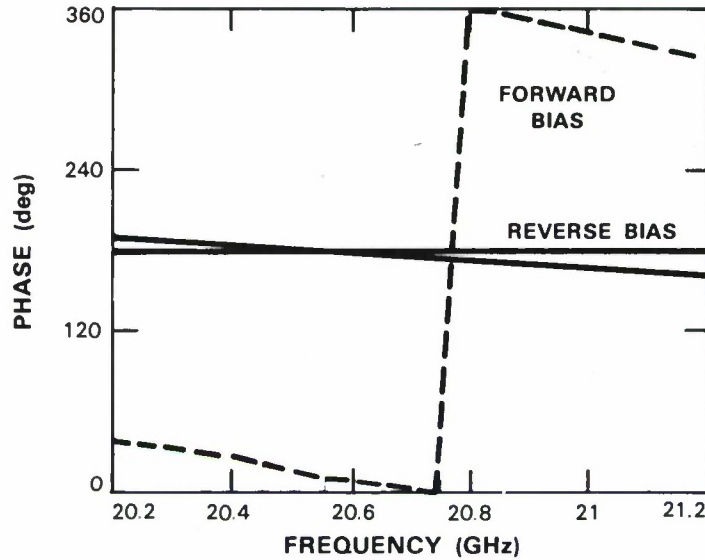

Figure 8. Typical reflection phase variation as diode bias condition changes.

As the diode was switched, a phase reversal of about  $180^\circ$  was obtained. The phase variation over the frequency band was about  $40^\circ$ .

Modifications to the full-scale mechanically tuned cavity feed were made in order to incorporate the diode switches. Figure 9 is a sketch showing a typical diode location in the feed. Coupling characteristics of the K-band circular coaxial waveguide to side cavity are effected by the details of the throat geometry and nearby dielectric Q-band wave-launcher. The measured results are given in Figure 10. Over the frequency band of interest, the measured coupling is flat within 1 dB. The coupling coefficient is about 21 dB.

Four diodes were selected based both on their quality and parity in performance. The selected diodes were integrated into the feed. First, each of the four selected diodes was inserted at the open end of each of four quarter-wave cavities in the throat of the feed horn. Next, each diode was tuned to parallel (forward bias) and series (reverse bias) resonance at 20.7 GHz by adjusting the positions of the diode and the RF blocking capacitors. Specially made waveguide transition fixtures were used to monitor the switching performance during this process. Figure 11 shows the location of the diode in the horn and transition fixtures.

The transition fixtures were removed and the feed was then installed in a reflector, and actual antenna beam-lobing was determined by measuring and comparing the antenna radiation patterns as the four diodes were switched in adjacent pairs. Figure 12 shows the tracking feed with the reflector antenna on a measuring pedestal.

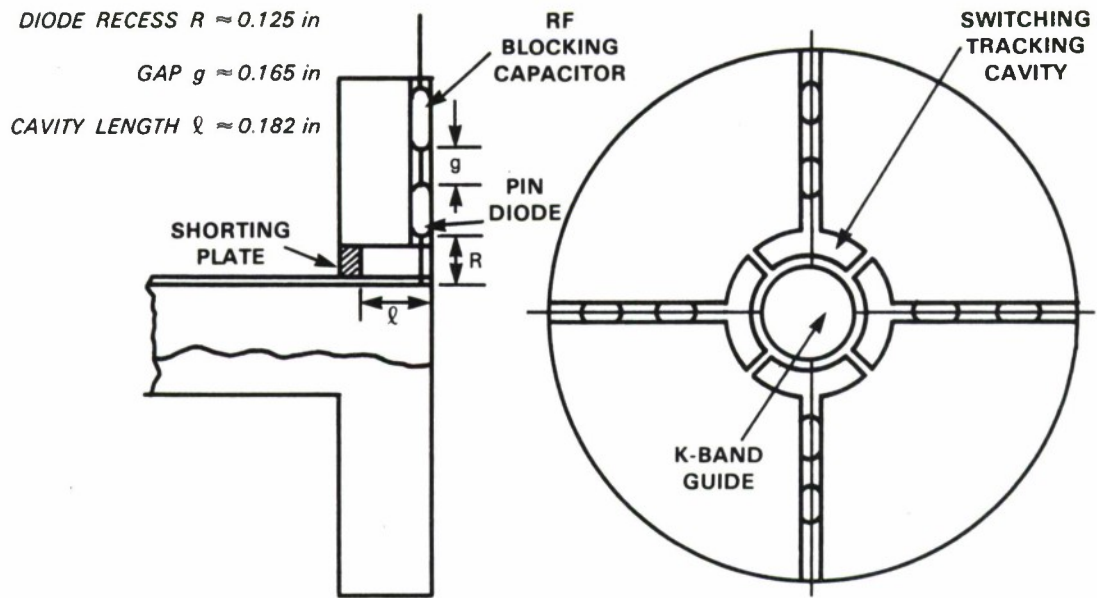

Figure 9. Details of diode location in the dual-band tracking feed.

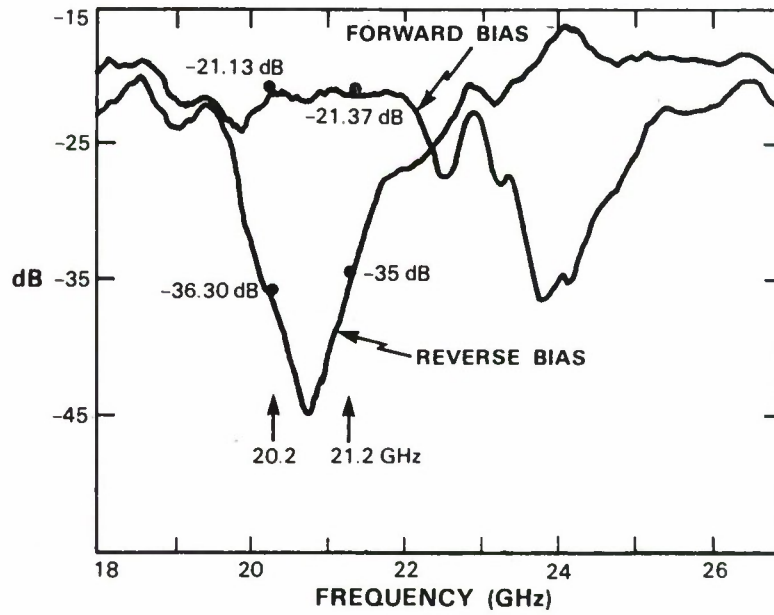

Figure 10. Coupling characteristics of coaxial waveguide to side cavity.

79451-12

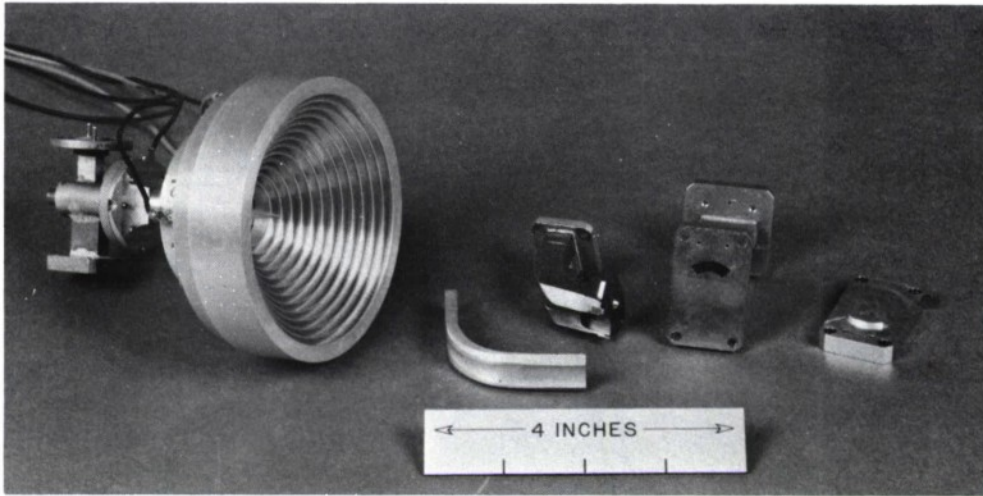

Figure 11. The tracking feed horn and the transition fixtures.

79451-13

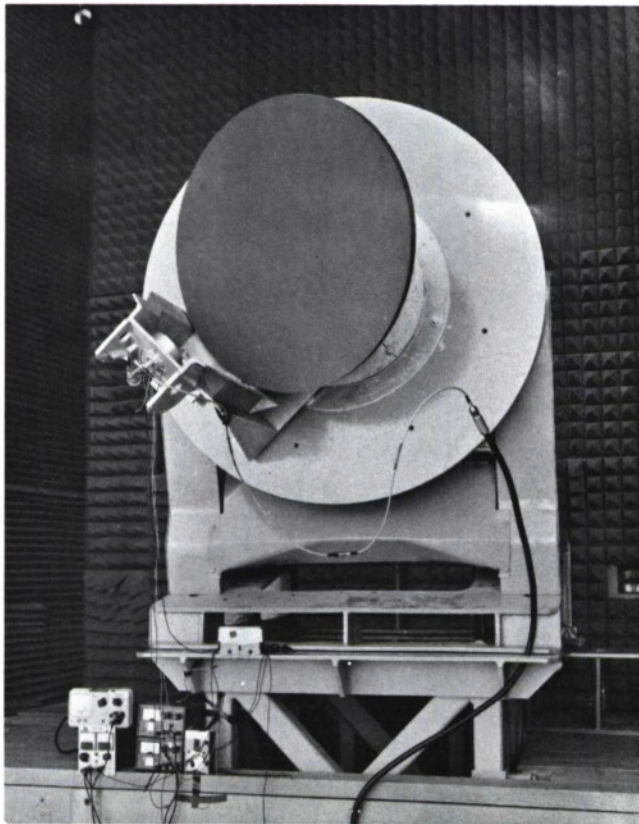

Figure 12. Tracking feed with reflector antenna on measuring pedestal.

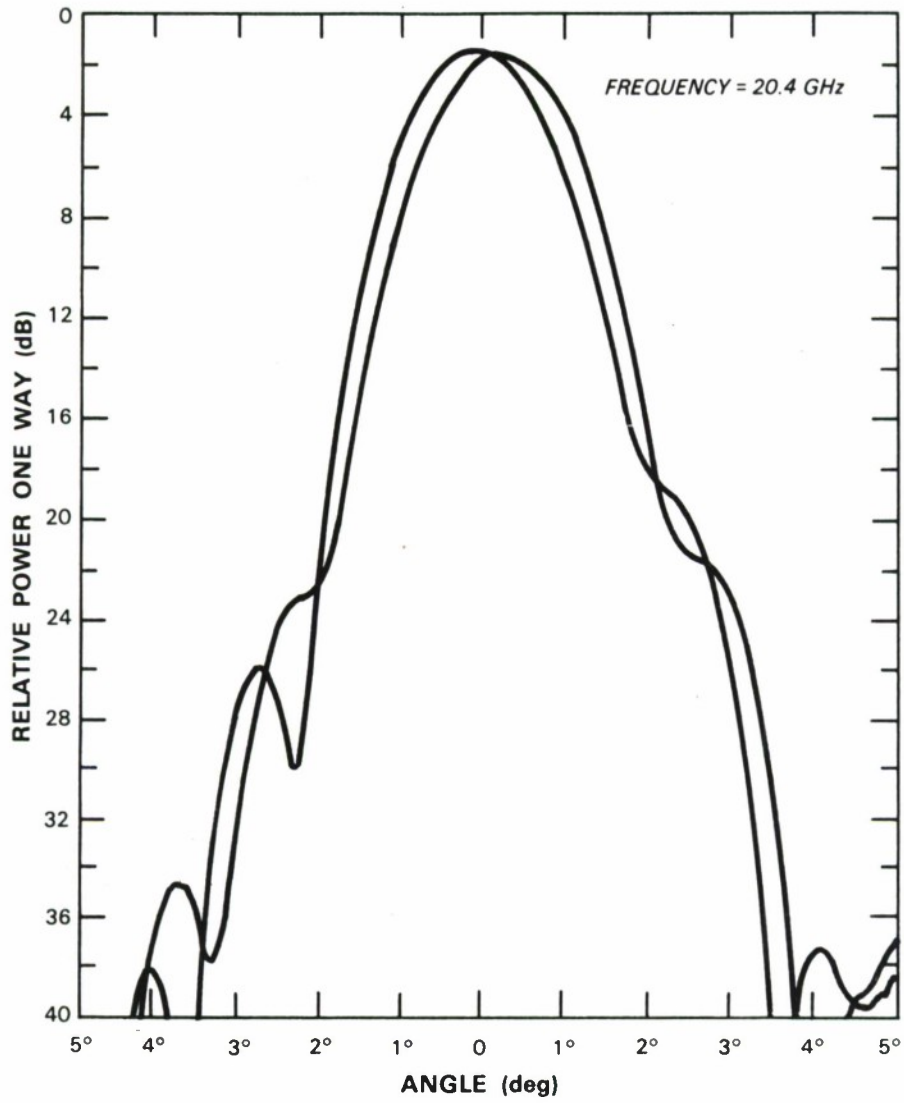

Figure 13. Measured beam-lobing patterns at 20.4 GHz.

Detailed measured results in 0.1-GHz increments showed clear beam squint at K-band but negligible squint at Q-band, as desired. Figures 13 to 17 show measured beam-lobing from 20.4 to 21.4 GHz as the four diodes were switched. Over the bandwidth of interest at K-band, both the beam width and beam squint vary somewhat. The center frequency for a 1-GHz bandwidth for the best K-band beam-squint performance is 20.9 GHz (about 1-percent higher than desired). This small frequency shift could be “tuned out” by pretuning the diode switch to a lower frequency.

Over the required frequency range, the average beam squint between the unbiased states and two pairs of diodes in oppositely biased states is  $0.17^\circ$ , with a standard deviation of  $0.06^\circ$ . This beam squint corresponds to an error slope of 0.4 and a crossover tracking loss of about 0.1 dB. The maximum beam squint is  $0.21^\circ$ ; the minimum is  $0.14^\circ$ . This is effectively within the required range of  $0.1^\circ$  to  $0.2^\circ$ . The average beam width is  $1.60^\circ$ . At certain frequencies, as the beam is switched, a slight change in beam peak level of up to about 0.2 dB was noticed. The suspected main causes are poor contacts at the diode leads and the cavity shorting plates. The maximum beam crossover pointing change due to this effect was about  $0.07^\circ$ .

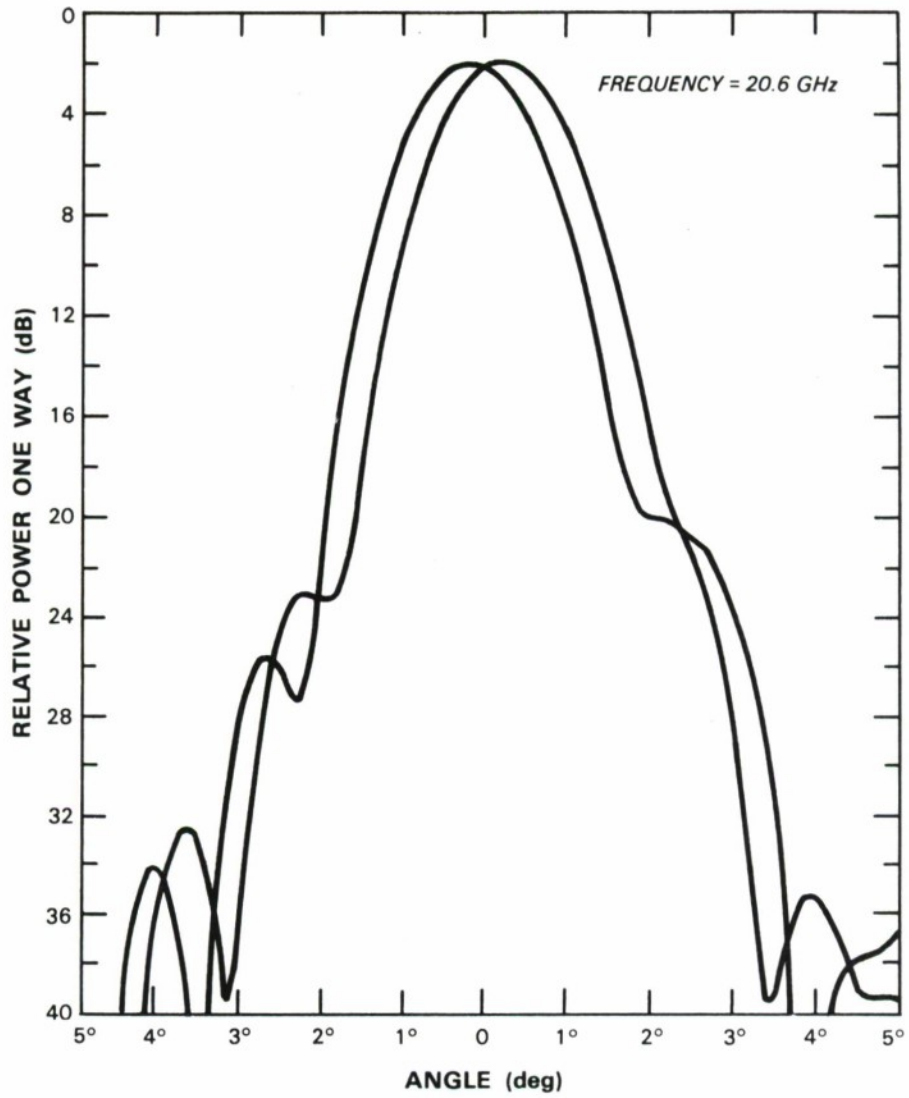

Figure 14. Measured beam-lobing patterns at 20.6 GHz.

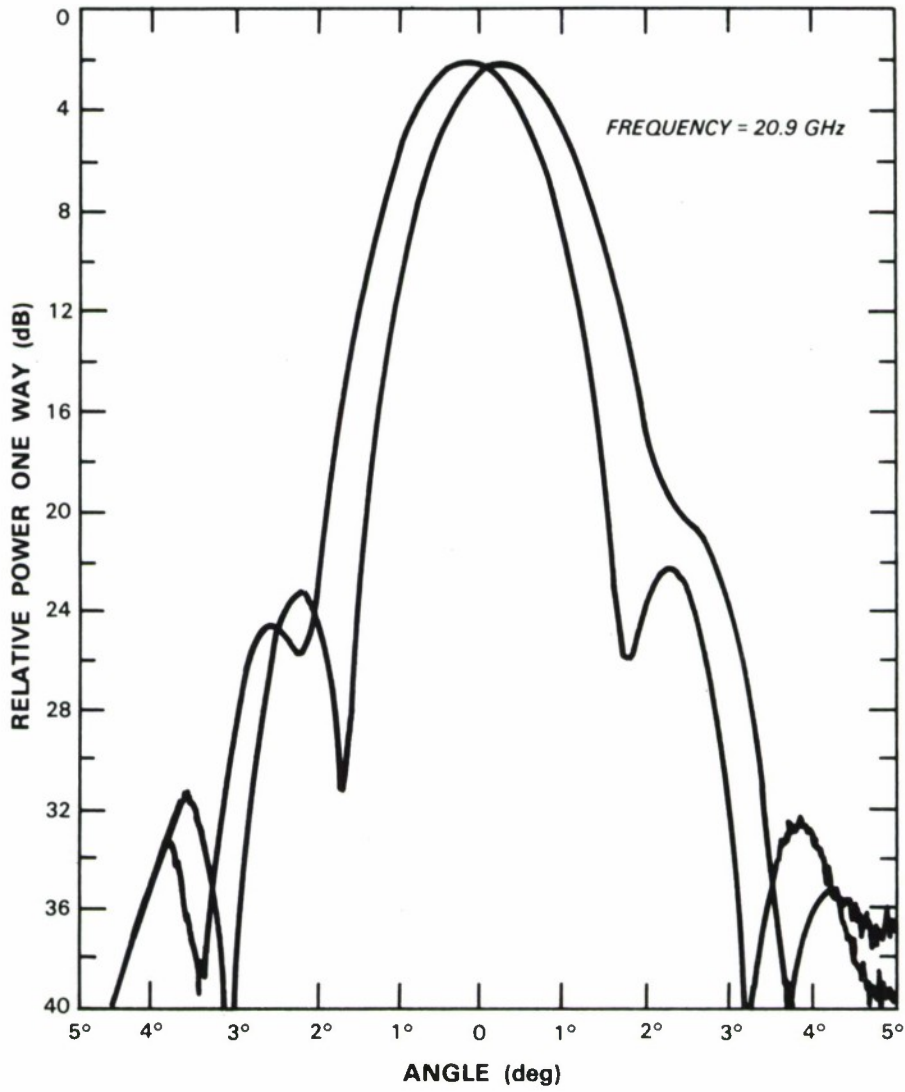

Figure 15. Measured beam-lobing patterns at 20.9 GHz.

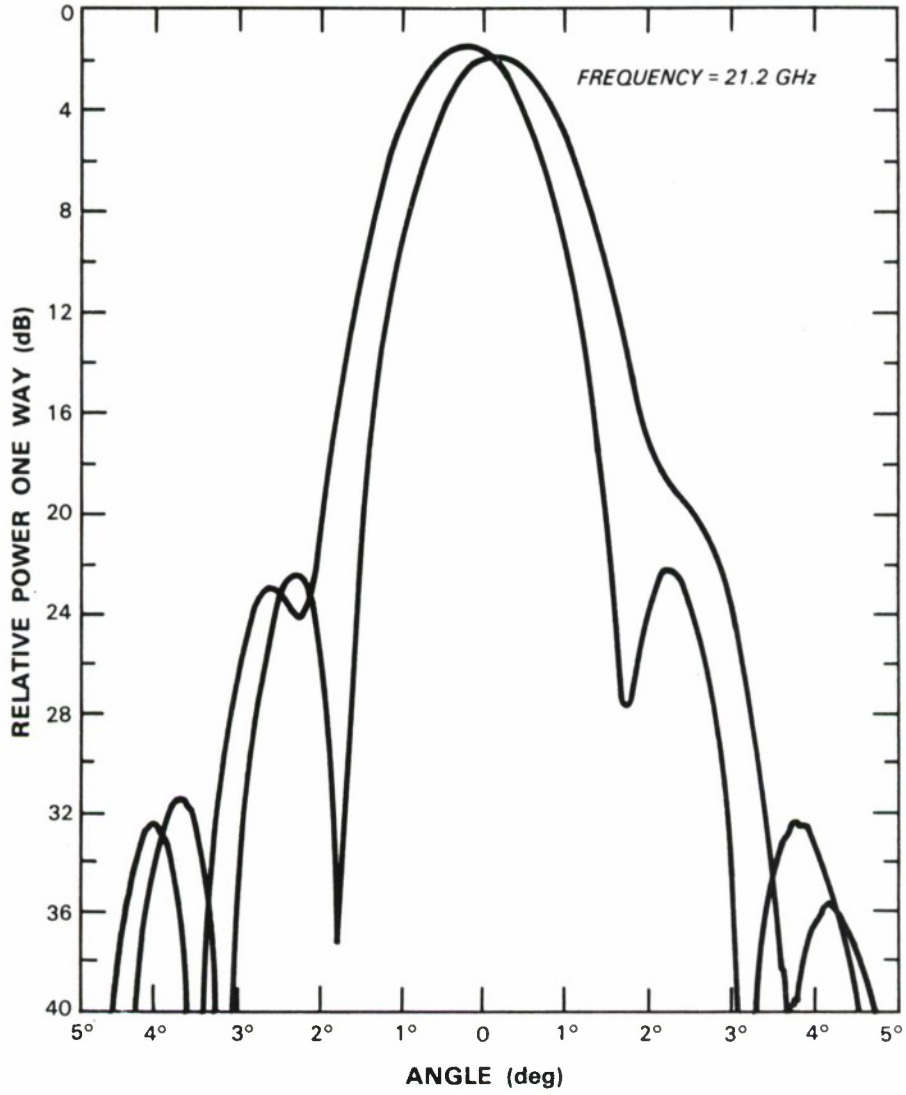

Figure 16. Measured beam-lobing patterns at 21.2 GHz.

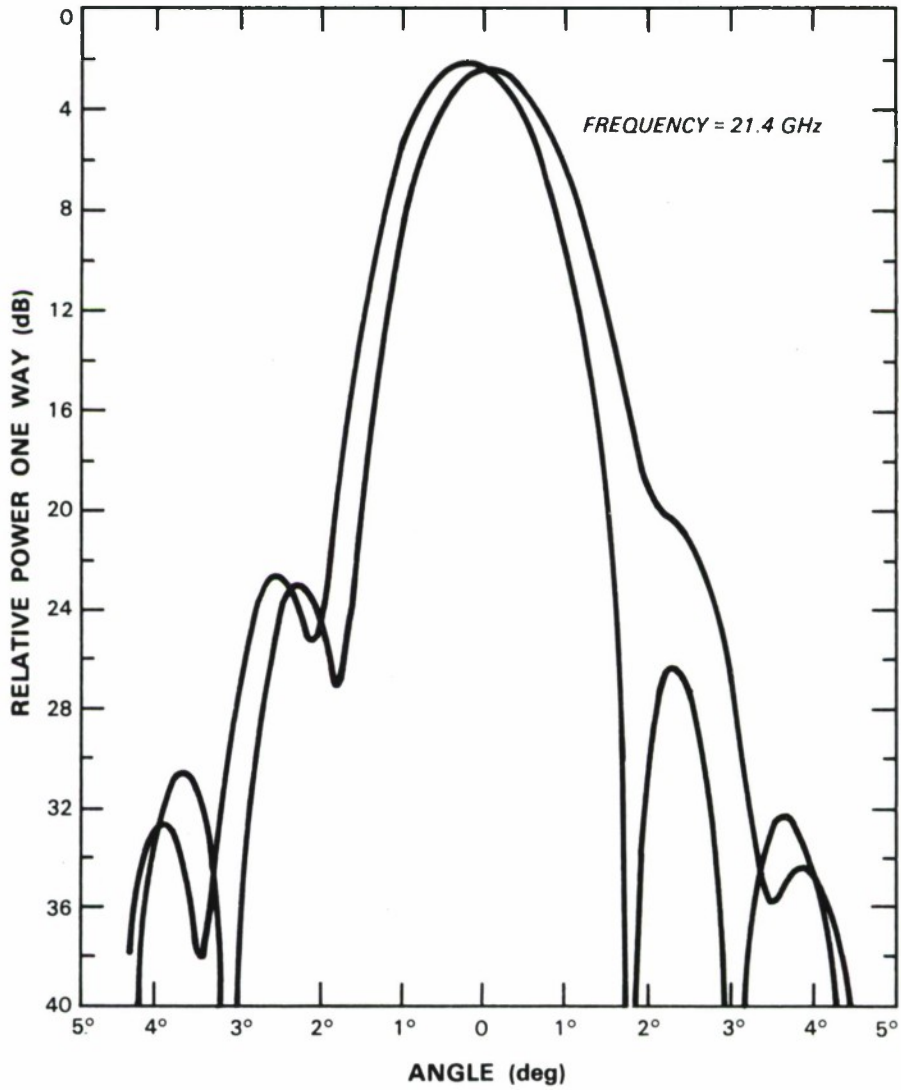

Figure 17. Measured beam-lobing patterns at 21.4 GHz.

## V. DISCUSSION AND CONCLUSIONS

From this development, we have demonstrated a compact dual-frequency feed with an electronic tracking capability achieved by adding four PIN diodes. Frequency sensitivity of the beam peak level change and beam squint should be reduced by more stringent diode selection, better diode lead contact to the feed, and better contact of the cavity shorting plates. In addition, using more than one diode in parallel in each cavity may result in broadbanding the diode reverse-bias switch reflection characteristics.

If more beam squint is desired, a tighter coupling to the cavities is needed. Experimentally, we found that tighter coupling can be obtained by partitioning the K-band coaxial waveguide opening with conducting posts. For mass production, a beam-lead diode-switching module in the form of a printed-circuit board could be mounted at the open ends of the quarter-wave cavities. This could be evolved from the present design. Finally, this tracking technique is, of course, not limited to dual-frequency feeds or reflector antennas; it could also be used, perhaps even more readily, for a single-frequency feed or lens antennas.

## ACKNOWLEDGMENTS

The author is grateful to Dr. Alan J. Simmons and Mr. William C. Cummings for their interest and support. I also express thanks to Messrs. John A. Russo, John P. McCrillis, and David S. Besse for their assistance in various measurements.

## REFERENCES

1. J.C. Lee, "A Compact Q-/K-Band Dual Frequency Feed Horn," IEEE Trans. Antennas Propag. **AP-32**, 1108 (1984), DTIC AD-A154214.
2. A.F. Sciambi, Jr., "Five-Horn Tracking Feeds for Large Antennas," 1966 Design and Construction of Large Steerable Aerials, p. 158.
3. T.B. Vu and N.V. Hien, "A New Type of High-Performance Monopulse Feed," IEEE Trans. Antennas Propag. **AP-21**, 855 (1973).
4. B.K. Watson and M. Hart, "A Primary-Feed for Electronic Tracking with Circularly-Polarized Beacons," Proceedings of Military Microwave Conference, June 1986, p. 261.
5. A.R. Dion, J.C. Lee, C.A. Lindberg, and A.J. Simmons, "LES-8/9 Antenna Systems Volume 3: K-Band," Technical Note 1977-48, Vol. 3, Lincoln Laboratory, MIT (30 December 1977), DDC AD-B026789-L.
6. J.S. Cook and R. Lowell, "The Autotrack System," Bell Syst. Tech. J. **42**, 1283 (1963).

UNCLASSIFIED

SECURITY CLASSIFICATION OF THIS PAGE

## REPORT DOCUMENTATION PAGE

1a. REPORT SECURITY CLASSIFICATION Unclassified			1b. RESTRICTIVE MARKINGS			
2a. SECURITY CLASSIFICATION AUTHORITY			3. DISTRIBUTION/AVAILABILITY OF REPORT Approved for public release; distribution unlimited.			
2b. DECLASSIFICATION/DOWNGRADING SCHEDULE						
4. PERFORMING ORGANIZATION REPORT NUMBER(S) Technical Report 779			5. MONITORING ORGANIZATION REPORT NUMBER(S) ESD-TR-86-198			
6a. NAME OF PERFORMING ORGANIZATION Lincoln Laboratory, MIT		6b. OFFICE SYMBOL (If applicable)	7a. NAME OF MONITORING ORGANIZATION Electronic Systems Division			
6c. ADDRESS (City, State, and Zip Code) P.O. Box 73 Lexington, MA 02173-0073			7b. ADDRESS (City, State, and Zip Code) Hanscom AFB, MA 01731			
8a. NAME OF FUNDING/SPONSORING ORGANIZATION Department of the Army, USASATCOMA		8b. OFFICE SYMBOL (If applicable)	9. PROCUREMENT INSTRUMENT IDENTIFICATION NUMBER F19628-85-C-0002			
8c. ADDRESS (City, State, and Zip Code) Fort Monmouth, NJ 07703			10. SOURCE OF FUNDING NUMBERS			
			PROGRAM ELEMENT NO. 33142A	PROJECT NO. 585	TASK NO.	WORK UNIT ACCESSION NO.
11. TITLE (Include Security Classification) A Dual-Frequency Feed with Electronic Tracking Capability						
12. PERSONAL AUTHOR(S) Lee, Joseph C.						
13a. TYPE OF REPORT Technical Report		13b. TIME COVERED FROM _____ TO _____		14. DATE OF REPORT (Year, Month, Day) 1987, May, 22		15. PAGE COUNT 34
16. SUPPLEMENTARY NOTATION None						
17. COSATI CODES			18. SUBJECT TERMS (Continue on reverse if necessary and identify by block number) dual-frequency feed      beam loping      PIN diodes Q-/K-band      diode switches      compact feed electronic tracking			
FIELD	GROUP	SUB-GROUP				
19. ABSTRACT (Continue on reverse if necessary and identify by block number)  A dual-frequency Q-/K-band circularly polarized feed with electronic tracking capability was developed. Four circumferentially located, externally coupled, diode controlled, resonant cavities were used at the horn throat to produce phase-center lateral movement. When used to feed a 24-in-diam. offset paraboloidal reflector, an average beam squint from boresight of 10 percent of the 3-dB beamwidth was obtained over a 5-percent bandwidth.						
20. DISTRIBUTION/AVAILABILITY OF ABSTRACT <input type="checkbox"/> UNCLASSIFIED/UNLIMITED <input checked="" type="checkbox"/> SAME AS RPT. <input type="checkbox"/> DTIC USERS				21. ABSTRACT SECURITY CLASSIFICATION Unclassified		
22a. NAME OF RESPONSIBLE INDIVIDUAL Maj. Thomas J. Alpert, USAF			22b. TELEPHONE (Include Area Code) (617) 863-5500 x2330		22c. OFFICE SYMBOL ESD/TML	