

AD-A182 359

IMPROVED CONNECTORS AND CABLES FOR RAPID DEPLOYMENT  
BATTLEFIELD POWER SYSTEMS PHASE 1(U) KOFORD ENGINEERING  
ADDISON IL S KOFORD 04 APR 87 DAAK70-86-C-0076

1/1

UNCLASSIFIED

F/G 10/2

NL

END  
DATE  
FORMED  
H

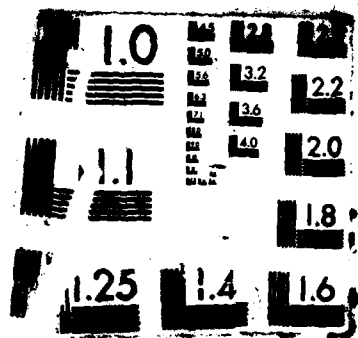

12

**DTIC FILE COPY**

**IMPROVED CONNECTORS AND CABLES FOR RAPID  
DEPLOYMENT BATTLEFIELD POWER SYSTEMS**

PHASE I FINAL REPORT

CONTRACT DAAK70-86-0076

**AD-A182 359**

**Prepared for US Army Belvoir Research &  
Development Center Procurement & Production Division  
Energy & Logistics Contracts Branch  
Fort Belvoir, VA**

by

Stuart Koford

**KOFORD ENGINEERING  
415 BELDEN AVE  
ADDISON, IL 60101**

**DTIC  
ELECTE  
JUL 15 1987**  
S D

April 4, 1987

**APPROVED FOR PUBLIC RELEASE.  
DISTRIBUTION UNLIMITED.**

87 7 2 088

## TABLE OF CONTENTS

1.	Introduction.....	2
2.	Cable design.....	3
3.	Reel design.....	21
4.	Connector design.....	29
5.	Conclusion.....	50

Accession For	
NTIS CRA&I	<input checked="" type="checkbox"/>
DTIC TAB	<input type="checkbox"/>
Unannounced	<input type="checkbox"/>
Justification .....	
By <i>lth on file</i>	
Distribution /	
Availability Codes	
Dist	Avail and/or Special
<i>A-1</i>	



## INTRODUCTION

Increased usage of electrical power in new sophisticated battlefield weapons systems and equipment in conjunction with the desire to reduce the number of generator sets in the field increases the need for improved electrical power distribution systems. These electrical systems should provide reduced weight, more rapid deployment/ redeployment, and improved durability under outdoor field conditions than current connector and cable systems in use for these applications. Improved connectors and cables are the key to achieving a rapidly deployable battlefield power system. Difficulties with the current high power circular connectors include, aluminum housings which dent and corrode, connectors which are heavy and bulky, thread on connection which is slow and awkward to use, silver contact plating exhibits poor environmental resistance over the long term and is limited to a relatively low number of insertions and withdraw cycles before wear thru occurs. The currently used round cable suffers from a lack of resistance to drive over damage, is heavy, and is awkward to store and deploy. The objectives of this project is develop design concepts for a new generation of interconnect system which provide a significant performance improvement over the current generation of equipment. The basis of this concept is a thermoplastic extruded flat cable which provides drive over capability without damage, and which also make coiling the cable easy. Wire reels are designed to be mounted to either the equipment to be powered, or to the distribution center, thus speeding deployment by eliminating the need to load and unload the cable as a separate item. The connectors will be of a rectangular configuration and molded from a high impact strength,

environmentally resistant engineering polymer to prevent dents and corrosion. The connectors are designed to be water tight when mated and dust resistant in the unmated condition. An important feature is the use of spring loaded doors to keep contamination out of unmated connectors rather than screw on caps which are dependent on users to remember to use them. Connectors are also designed to take the forces of being driven over without failure. A major feature of the entire system is light weight with weight savings achieved in both the cable by the use of high performance low density insulation and compact design, and in the connectors with engineering polymer construction.

## CABLE DESIGN

A flat cable design was chosen for this project because of the following advantages: 1) Rectangular profile is ideally suited to reel storage of cable, 2) Flat profile greatly improved the ability to withstand running over of the cable by vehicles, 3) The rectangular profile allows reduced total size and weight. Since flat cables of the size required do not presently exist cables were designed to fit each of the voltage and current combinations established in the EDICTS system. The round cables presently used have multiple small gauge grounds distributed between current carrying wires to try to ensure that under a crushing load a fault will occur to ground before one occurs between power leads. The flat cable configuration however does not have this failure mode since the cables do not cross over each other and therefore a single ground of size equal to the power leads has been used located centered between the power leads. A two layer insulation system has been chosen with 1,000 volt flurocarbon insulation over the stranded conductors and the insulated wires then jacketed with a thermoplastic elastomer via extrusion. This is an economical high speed process and the technology is wide available. Several choices exist for the elastomer including urethane, polyester (Hytrel®), TPR, and nylon block copolymers, all of these materials are harder, and stronger then the SBR or natural rubber typically used in car and truck tires, preventing crushing or cut thru. A previous study directed by the author for TACOM showed that Neoprene which is typically used for cable jacketing has poor long term environmental resistance. The use of flurocarbon wire insulation provides an insulation with excellent cut thru strength

and outstanding resistance to environmental conditions. The elastomeric jacketing holds together the strands and provides additional cut thru resistance. Since the mechanical properties are much higher than those of Neoprene, greatly reduced thickness are required. Several kinds of fluoro-carbon insulation are available including FEP, TFE, and Tefzel®, of these Tefzel® has the best cut thru properties, while TFE has the greatest temperature resistance.

An engineering drawing was prepared of the 20 AMP 1Ø size cable and quotes requested with TFE, FEP, or Tefzel primary insulation and Hytrel, TPR, or urethane jacketing with a quantity of 50,000 feet. The cable was designed with 65 strands of 30 gauge tinned copper to provide flexibility and long flex life. Based on the quotations prices can be expected to run at 45¢ per foot for TPR jacketing over TFE, and up to \$1.12 for Hytrel jacketing over FEP demonstrating the excellent economies of this approach.

To evaluate the cost performance trade off between the TPR and Hytrel or Urethane sample cables should be fabricated and tested for roll over and UV resistance. The following data sheets show that while the Telcar 3707 TPR has a tensile strength of 1700 psi, Estane 58013 polyurethane has a tensile strength of 7,800 psi, and Hytrel 55D has a tensile strength of 3,700 but twice the tear strength and better UV resistance than the Urethane.



	<u>Telcar 3707</u>	<u>ASTM</u>
Specific Gravity ( $\pm 0.02$ )	0.90	D-792
Hardness (Shore 'A' Duro. $\pm 3$ ) 15 Second Reading	84	D-2240
Tensile Strength (lbs./sq.in.)	1700	D-412
Elongation, %	675	D-412
Aged 7 days @ 136°C.		D-1870
% Tensile Retention	160.0	
% Elongation Retention	81.0	
% Weight Loss	--	
Deformation, $T_2/T_1$ , 150°C., 200 gms.	0.62	
Melt Index 230°C., 2160 gms.	1.5	D-1238
Brittle Point, Model 'E', °C.	-60	D-746

**TABLE 1** Typical Mechanical Properties

Property†	Units	ASTM Method	HYTREL® Polyester Elastomer Hardness (Durometer) Grades			
			400	550	63D	72D
Tensile Strength	psi	D-638	3 700	5 500	5 700	5 700
	MPa		25.5	37.9	39.3	39.3
Ultimate Elongation	%	D-638	450	450	350	350
25% Modulus or Yield Point	psi	D-638	1 100 (M25)	2 000 (M25)	2 500 (Yield)	3 800 (Yield)
	MPa		7.6	13.8	17.2	26.2
Stress at 15% Compression	psi	D-575A	1 100	2 500	3 100	4 400
	MPa		7.6	17.2	21.4	30.3
Flexural Modulus	psi	D-790	7 000	30 000	50 000	75 000
	MPa		48.3	207	345	517
Resilience, Bashore	%	—	62	53	43	Not applicable
Compression Set Resistance, 22 hours at 158°F (70°C)						
25% Deflection	%	D-395B	60*	56*	Not applicable	Not applicable
Constant Load, 1350 psi (9.3 MPa)	%	D-395A	27	4	2	2
Tear Strength						
Die B	lb/in	D-624	631	935	1 055	Not applicable
	kN/m		110	164	185	
Die C	lb/in	D-624	700	900	850	Not applicable
	kN/m		122	158	149	
Resistance to Flex Cut Growth						
Ross (Pierced)	cycles to failure	D-1052	>3x10 <sup>5</sup>	>3x10 <sup>5</sup>	2.8x10 <sup>5</sup>	Not applicable
DeMattia (Pierced)	cycles to failure	D-813	>2x10 <sup>5</sup>	>7x10 <sup>4</sup>	Not applicable	Not applicable
Notched Impact, Izod						
at 75°F [24°C]	ft-lb/in	D-256A	>20 (No 10.6 break)	>20 (No 10.6 break)	>20 (No 10.6 break)	3.9
	J/cm					2.1
at -40°F [-40°C]	ft-lb/in	D-256A	>20 (No 10.6 break)	>20 (No 10.6 break)	0.5	0.8
	J/cm				0.3	0.4
Taber Abrasion						
CS-17 Wheel, 1000 g load	mg/1000 cycles	D-1044	3	5	8	13
Softening Point, Vicat						
	°F	D-1525	234	356	363	397
	°C		112	180	184	203
Heat Distortion Temperature						
66 psi [0.5 MPa]	°F	D-648	No data	315	No data	330
	°C			157		166
264 psi [1.8 MPa]	°F	D-648	No data	110	No data	155
	°C			43		69
Brittleness Temperature						
	°F	D-746	<-94	<-94	<-94	<-94
	°C		<-70	<-70	<-70	<-70
Coefficient of Linear Expansion						
	in/in/°C	D-696	20x10 <sup>-5</sup>	18x10 <sup>-5</sup>	17x10 <sup>-5</sup>	21x10 <sup>-5</sup>
	mm/mm/°C		20x10 <sup>-5</sup>	18x10 <sup>-5</sup>	17x10 <sup>-5</sup>	21x10 <sup>-5</sup>
Water Absorption, 24 hours	%	D-570	0.6	0.5	0.3	0.3
Specific Gravity	—	D-720	1.17	1.20	1.22	1.25

† Properties were measured on injection-molded test specimens  
 \* Can be improved by annealing

® Reg. U.S. Pat. & Tm. Off.

# Estane<sup>®</sup>

*Polyurethanes*

## TECHNICAL DATA

ESTANE 58092 COMPOUND

	<u>*Typical Value</u>	<u>ASTM No.</u>
Specific Gravity	1.25	D-792
Hardness, Durometer	A/95/1; D/48/1	D-2240-68
Ultimate Tensile Strength (psi)	5000	D-412-68
Modulus at 300% Elongation (psi)	3100	D-412-68
Ultimate Elongation (%)	450	D-412-68
Graves Tear (lbs/in)	670	D-624
Low Temperature Brittleness Point (°F)	-81	D-746
Gehman Low Temperature Moduli, (°C)		D-1053
T <sub>2</sub>	-4	
T <sub>5</sub>	-11	
T <sub>10</sub>	-16	
Freeze Point	-23	
Compression Set, ASTM Method B		D-395
22 hours at 25°C (%)	18	
22 hours at 70°C (%)	65	
Taber Abrasion (wt. loss, mg. per 1000 cycles)		
(CS17 wheel, 1000 gms. weight, 5000 cycles)	2.6	

Stockable Color: Natural 021

\* Representative data on typical production material.

Description: Sheet and film extrusion and blown film compound. For use where toughness exceeding 58013 is required.

Note: Although Estane 58092 compound is dry when packaged, moisture absorption is characteristic of polyurethane materials. Such moisture absorption may occur during transportation, storage or use of the material. Drying of this material prior to usage is recommended. Suggested drying conditions are two hours at 220°F in a circulating air oven or similar equipment.

6909

B.F. Goodrich Chemical Company / 6100 Oak Tree Blvd., Cleveland, Ohio 44131



These data are based on tests believed to be reliable. They are given only for your information and no warranty, express or implied, is made as we cannot guarantee the results of operations not under our direct control. The information in this publication is not intended as permission or recommendation to practice the stated operation without permission of the patent owner or inventor.

# Estane<sup>®</sup>

*Polyurethanes*

## TECHNICAL DATA

ESTANE 58013 COMPOUND

	<u>*Typical Value</u>	<u>ASTM No.</u>
Specific Gravity	1.21	D-792
Hardness, Durometer	A/86/1	D-2240-68
Ultimate Tensile Strength (psi)	7800	D-412-68
Modulus at 300% Elongation (psi)	1200	"
Ultimate Elongation (%)	360	"
Graves Tear (lbs/in)	440	D-624
Low Temperature Brittleness Point (°F)	-100	D-746
Low Temperature Moduli, (°C)		D-1053
T <sub>2</sub>	-11	
T <sub>5</sub>	-20	
T <sub>10</sub>	-24	
T <sub>50</sub>	-36	
T <sub>100</sub>	-46	
Freeze Point	-29	
Compression Set, ASTM Method B		D-395
22 Hours at 25°C (%)	24	
22 Hours at 70°C (%)	67	
Taber Abrasion (Weight loss, mg. per 1000 cycles)	2.5	
(CS17 wheel, 1000 gms. weight, 5000 cycles)		
Ozone Aging		
50 pphm, 20% stretch, 120°F for 144 hours	No Cracks	D-1149

Stockable Color: Natural 021

\*Representative data on typical production material.

Description: General extrusion compound.

Note: Although Estane 58013 compound is dry when packaged, moisture absorption is characteristic of polyurethane materials. Such moisture absorption may occur during transportation, storage or use of the material. Drying of this material prior to usage is recommended. Suggested drying conditions are two hours at 220 F in a circulating air oven or similar equipment.

B.F. Goodrich Chemical Company / 6100 Oak Tree Blvd., Cleveland, Ohio 44131

**BFGoodrich**

These data are based on tests believed to be reliable. They are given only for your information and no warranty, express or implied, is made as we cannot guarantee the results of operations not under our direct control. The information in this publication is not intended as permission or

6909

# MECHANICAL PROPERTIES

## Typical Room Temperature Data (70°F)

**TABLE I**  
**PHYSICAL PROPERTIES OF CYANAPRENE THERMOPLASTIC POLYURETHANES**

PROPERTY	TEST METHOD	1880	1890	1850	1857
Hardness, Shore A or D	ASTM D-2240	80A	90A	50D	57D
Ultimate Tensile Strength, psi	ASTM D-412	6000	5500	5500	8000
Tensile Modulus, psi	ASTM D-412				
at 100% Elongation		700	1100	1800	2250
at 200% Elongation		900	1600	2300	2850
at 300% Elongation		1400	2200	3000	3850
Ultimate Elongation, %	ASTM D-412	750	700	650	600
Elongation Set at Failure, %	ASTM D-412	15	35	45	37
Compression Modulus, psi	ASTM D-575				
at 5% Deflection		100	200	400	410
at 10% Deflection		250	450	800	990
at 25% Deflection		750	1250	2250	2960
Compression Set, %	ASTM D-395-B				
22 Hours at 158°F, 25% Defl.		28	(27)	30	29
22 Hours at 212°F, 25% Defl.		42	41	40	41
22 Hours at 250°F, 25% Defl.		88	59	69	86
Abrasion Resistance, Taber	ASTM D-1044				
4-18 Wheel, mg per 1000 Cycles		10	35	46	156
Char Strength, Die C, pli	ASTM D-624	550	720	820	800
Melting Point, °F	ASTM D-746	-90	-90	-90	-90
Impact Resilience (percent Rebound)	ASTM D-2632	37	29	31	21
Compression, NBS	ASTM D-1630	413	840	780	340
Coefficient of Linear Thermal Expansion, 10 <sup>-5</sup> /°F	ASTM D-696	11.2	11.2	11.2	6.4 <sup>1</sup> 8.3 <sup>2</sup>
Specific Gravity	ASTM D-792	1.25	1.25	1.27	1.27

15°C  
100°C

Parts properly fabricated with CYANAPRENE thermoplastics will exhibit the typical properties shown in Table I. Typical room temperature (70°F) stress-strain curves are shown in Figure 1.

**STRESS/STRAIN PROPERTIES  
ROOM TEMPERATURE (70° F)**

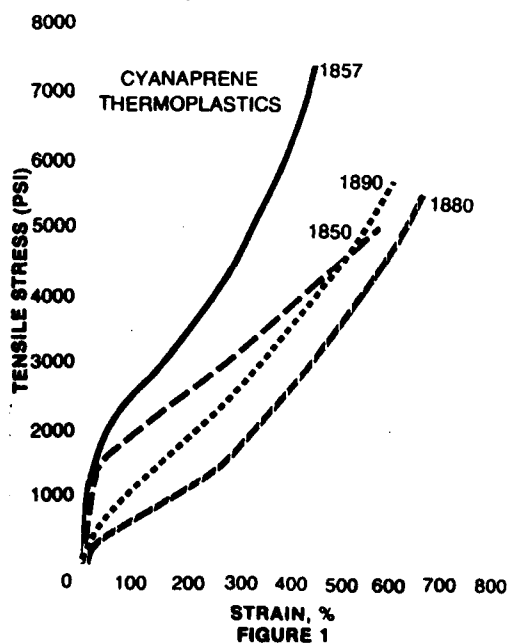

to tension set after a 100% ten- sile elongation is good for all grades of SANTOPRENE rubber. The low compression and ten- sion set of the softer grades of the rubber make them well suited for many applications which at present can only be fulfilled by vulcanized rubbers.

The brittle point for all grades of SANTOPRENE rubber, except 103-50 and 203-50, is well below -40°C (-40°F), and all grades have good low-temperature flex- ibility. Naturally, the softer grades have a greater degree of low temperature flexibility.

The abrasion resistance of SANTOPRENE rubbers has proven to be superior to many vulca- nized rubber compounds in a variety of applications. Actual abrasion resistance for a given application is heavily depen- dent on the nature of the service conditions, and laboratory data can only provide an initial esti- mate of final product perform- ance. The data in Table I clearly indicate the excellent abrasion resistance of these grades com- pared to natural rubber tire tread stocks using the NBS Abrasion Index.

The flex fatigue of SANTOPRENE rubbers is also extremely high compared to many thermoset rubber compounds. Because of the great variety of flex fatigue applications, it is recom- mended that SANTOPRENE rubber be tested for fatigue resistance in accordance with the potential end use perfor- mance requirements.



The Monsanto T-500 Tensometer is used to assure consistent product quality for SANTOPRENE® rubber.

## MECHANICAL PROPERTIES OF SANTOPRENE® THERMOPLASTIC RUBBER

### Typical Properties\*

Properties	ASTM Test Method	Test Temp. (°C)	Units	201-73	201-80	201-87	203-40	203-50
				101-73	101-80	101-87	103-40	103-50
Hardness	D-2240	25	5 sec. Shore	73A	80A	87A	40D	50D
Specific Gravity	D-297	25	—	0.98	0.97	0.96	0.95	0.94
Tensile Strength	D-412	25	PSI MPa	1100 7.6	1400 9.7	2200 15.2	2650 18.2	3900 26.9
Ultimate Elongation	D-412	25	%	375	400	530	600	600
100% Modulus	D-412	25	PSI MPa	470 3.2	650 4.6	1000 6.9	1250 8.6	1450 10.0
Tear Strength	D-624	25	PLI KN/m	150 26	203 36	304 53	422 74	639 112
		100	PLI KN/m	60 11	80 14	150 26	240 42	331 58
Tension Set	D-412	25	%	14	20	33	48	61
Compression Set	D-395	25 100	% %	25 33	27 39	35 52	39 65	— —
Brittle Point	D-746	—	°C	<-60	-60	-60	<-40	-34
Abrasion	D-1630	25	NBS Index %	54	84	201	572	>600

\*Typical properties based on samples tested in our laboratory — injection molded plaques using a 3.20 inch wide by 4.5 inch long by 0.115 inch thick plaque with an edge gate in the upper corner. These data are not guaranteed for all samples. Write to us for our current sales specifications.

**WEATHERABILITY OF SANTOPRENE® RUBBERS  
XENON ARC WEATHEROMETER  
TENSILE PROPERTIES AFTER EXPOSURE**

Time Hrs.	201-73			203-40		
	Tensile Strength (psi)	Elong. (%)	100% Modulus (psi)	Tensile Strength (psi)	Elong. (%)	100% Modulus (psi)
0	1100	375	470	2600	560	1180
500	1130	350	520	2550	540	1260
1000	1190	350	520	2530	550	1240

These data are based upon samples tested in our laboratory and are not guaranteed for all samples. Write us for our current sales specifications.

**HEAT AGING — % RETENTION  
OF MECHANICAL PROPERTIES  
AT 125°C (257°F)**

	1	7	Days 15	30	41.7 (1000 hrs.)
<b>101 &amp; 201-73</b>					
Tensile Strength	100	105	115	120	120
% Elongation	90	90	90	90	90
100% Modulus	105	110	120	120	120
<b>101 &amp; 201-80</b>					
Tensile Strength	100	115	115	115	125
% Elongation	90	90	90	80	80
100% Modulus	105	110	115	115	120
<b>101 &amp; 201-87</b>					
Tensile Strength	100	105	105	110	110
% Elongation	95	90	90	90	90
100% Modulus	110	110	115	115	120
<b>103 &amp; 203-40</b>					
Tensile Strength	105	105	105	110	110
% Elongation	95	90	90	90	90
100% Modulus	110	115	120	120	125

These data are based upon samples tested in our laboratory and are not guaranteed for all samples. Write to us for our current sales specifications.

**ENVIRONMENTAL  
STABILITY**

The environmental stability of the compound is excellent and exceeds many thermoset rubbers. Table III illustrates the retention of physical properties for SANTOPRENE rubber grades 201-73 and 201-40 after exposure in a xenon arc weatherometer. The retention of tensile strength, elongation and 100% modulus after 1000 hours is in excess of 85% in all cases.

Many thermoset rubbers deteriorate on prolonged exposure to air, oxygen or ozone. SANTOPRENE rubbers are designed to be resistant to these gases. Testing according to ASTM D-518 demonstrates that all grades pass the required criteria after 70 hours in 50 ppm ozone.

Extensive heat aging of rubber compounds frequently cause a severe change in mechanical properties. Table IV illustrates the retention of tensile strength, elongation and 100% modulus for SANTOPRENE rubbers after hot air aging for up to 1000 hours (41 days) at 125°C (257°F). SANTOPRENE rubbers show a change in these mechanical properties of less than 25% for all conditions. This excellent hot air aging represents a significant performance advantage compared to most thermoset rubber compounds. Improved heat aging can be achieved by the addition of additives designed for this purpose.

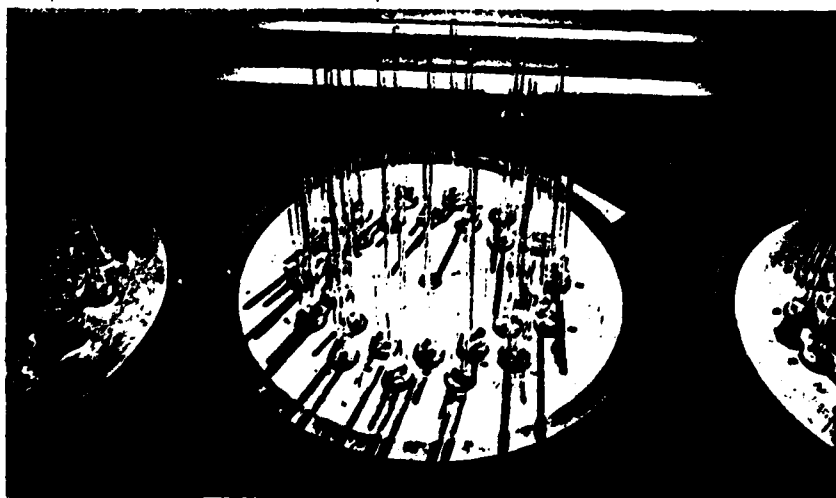

SANTOPRENE® rubber has excellent heat aging characteristics.

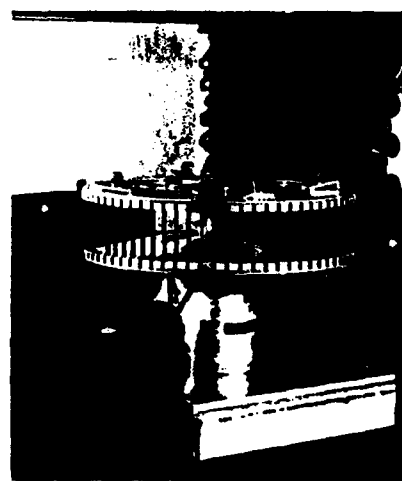

SANTOPRENE® rubber has superior static and dynamic ozone resistance.

## REEL DESIGN

An important feature of this project is the use of wire reels for storing the wire rather than using loose connectorized cables. This not only prevents damage to the connectors, but by permanently attaching the reel to either the unit to be powered or the distribution center the heavy cable does not have to be handled separately. Since only the amount of cable to be used needs to be unreeled, damage to excess cable is prevented. A 50 foot length was selected for the reels. Longer runs if necessary could be accomplished with portable extension reels. In this case the ease of handling a compact reel with carrying handle and wind up crank is much greater than dealing with loose wire. The configuration of the reel would typically involve a molded plastic spool which the wire would be wound on, and which would have a built in extension to function as a winding handle, this would be surrounded by a two piece case in which the spool would rotate. The loose end of the wire would be terminated with a female connector, while the other end would enter the interior of the spool thru a slot and terminate in either a slip ring, a female connector attached to a length of wire, or for extension reels a female connector mounted on the spool of the reel. For permanently affixed connectors the slip ring would provide the greatest convenience because the wire would be simply dereeled to use, however this approach would lead to somewhat greater complexity and cost. The alternative would be to have a female connector attached to a short length of cable, after dereeling the connector would be mated to a male connector, affixed to the powered device. For shipping and the connector would be left in the mated condition to prevent shock and vibration damage

damage to the connector. The case could be made from RIM to minimize tooling costs on large parts, while the spool would be injection molded from the same material used for the connector. Designs for several cable sizes follow and well as concepts on the termination of the reel spool by slip rings.

HYTREL 40 D

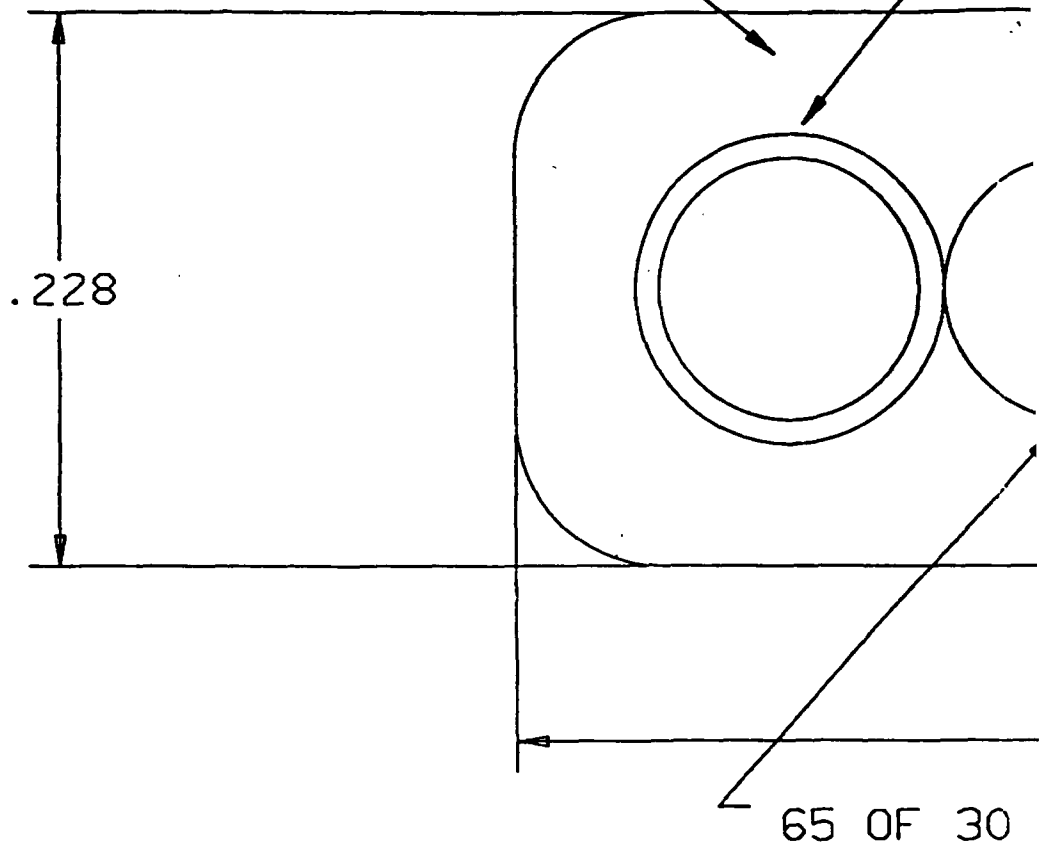

65 OF 30 GAUGE TINNED  
.010 TFE INSULATED

R.060

.464

OF 30 GAUGE TINNED

KOFORD ENGINEERING			
SCALE 4" / 1"	TITLE CABLE 20A 1 PHASE		
REVISIONS	MATERIAL PER NOTES	DRAWING NO.	DESIGNED KOFORD 1/4/87

2

EXTRUDED ELASTOMERIC JACKET

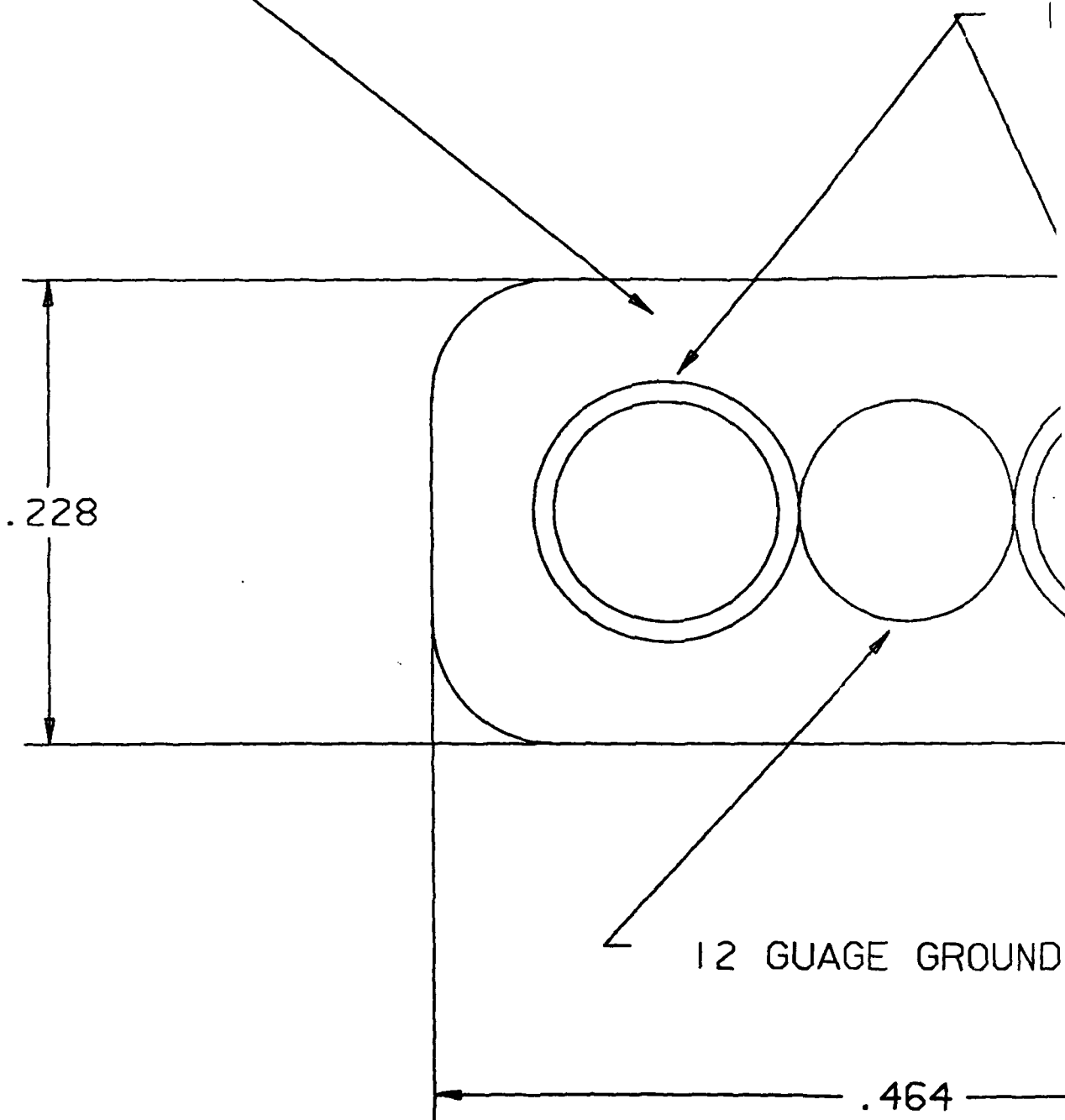

12 GAUGE GROUND

120/240V, 20AMP 1-PH

CKET

12 GAUGE WITH TFE INSULATION 600V

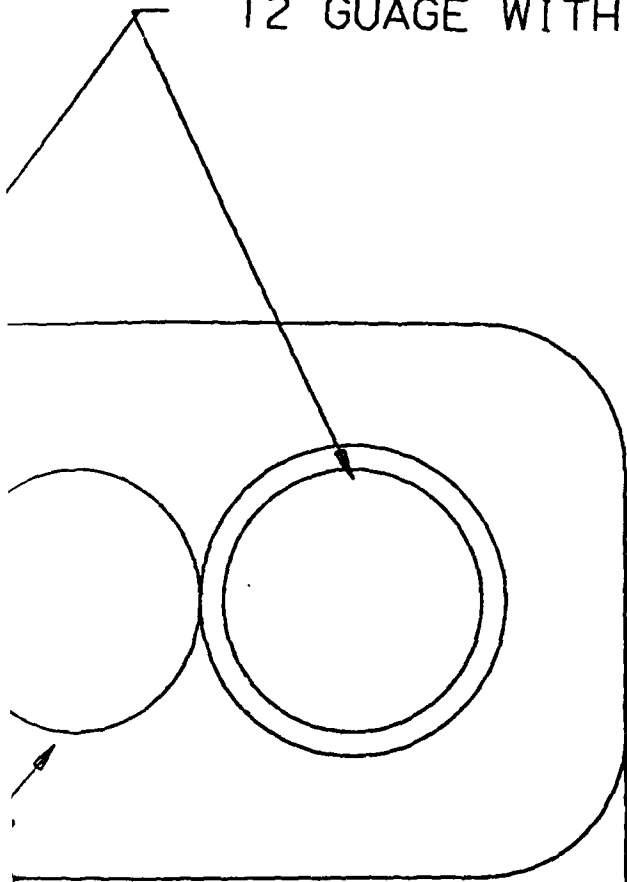

GE GROUND WIRE

464

1-PHASE FLAT CABLE

*Handwritten mark*

EXTRUDED ELASTOMERIC JACKET

4 GL

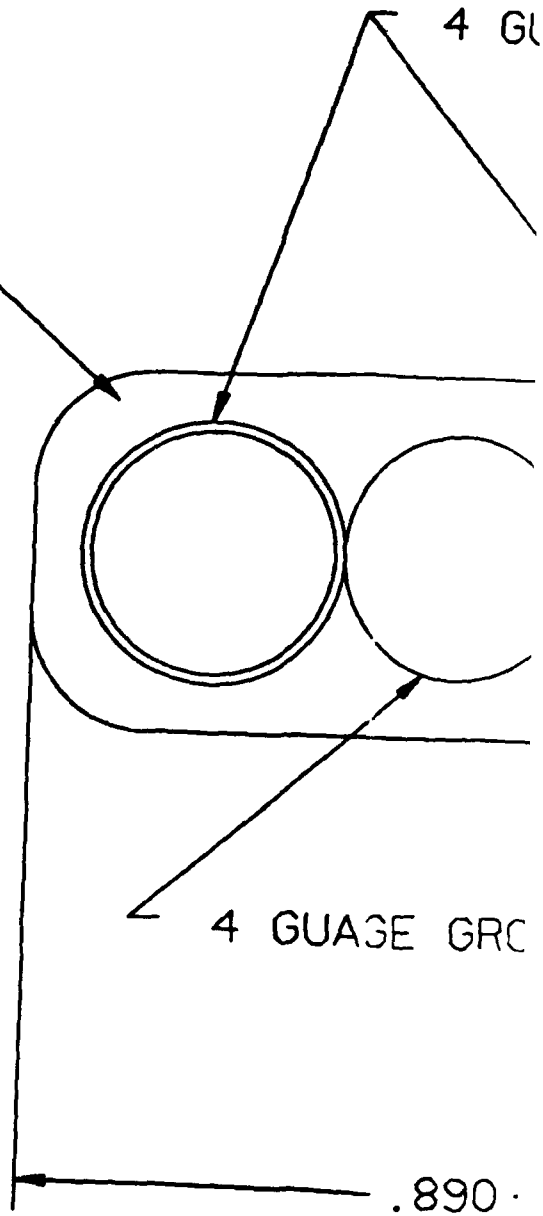

4 GAUGE GRC

.890

120/208V

60AMP

JACKET

4 GAUGE WITH TFE INSULATION 600V

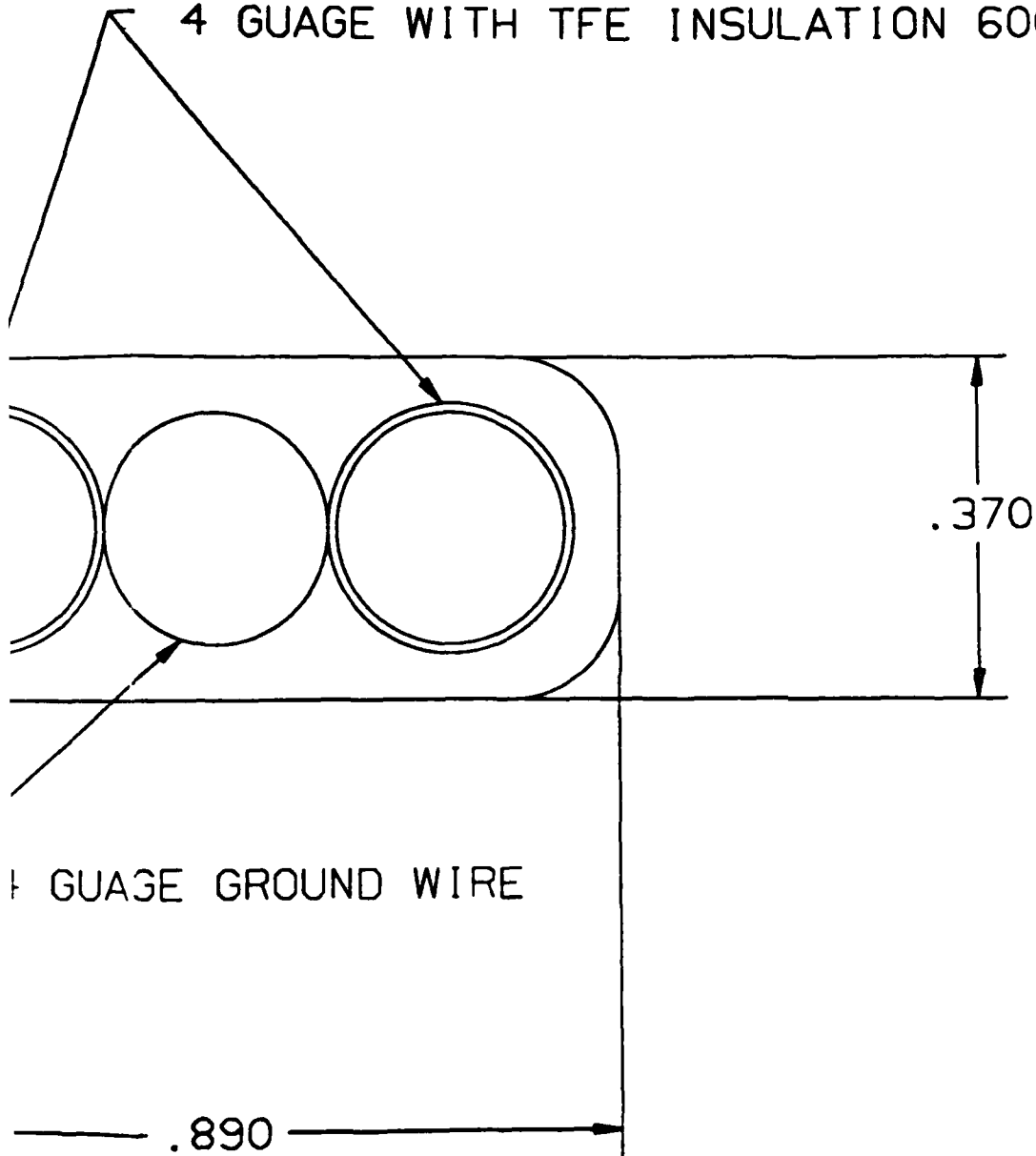

CAMP 1-PHASE FLAT CABLE

1

2

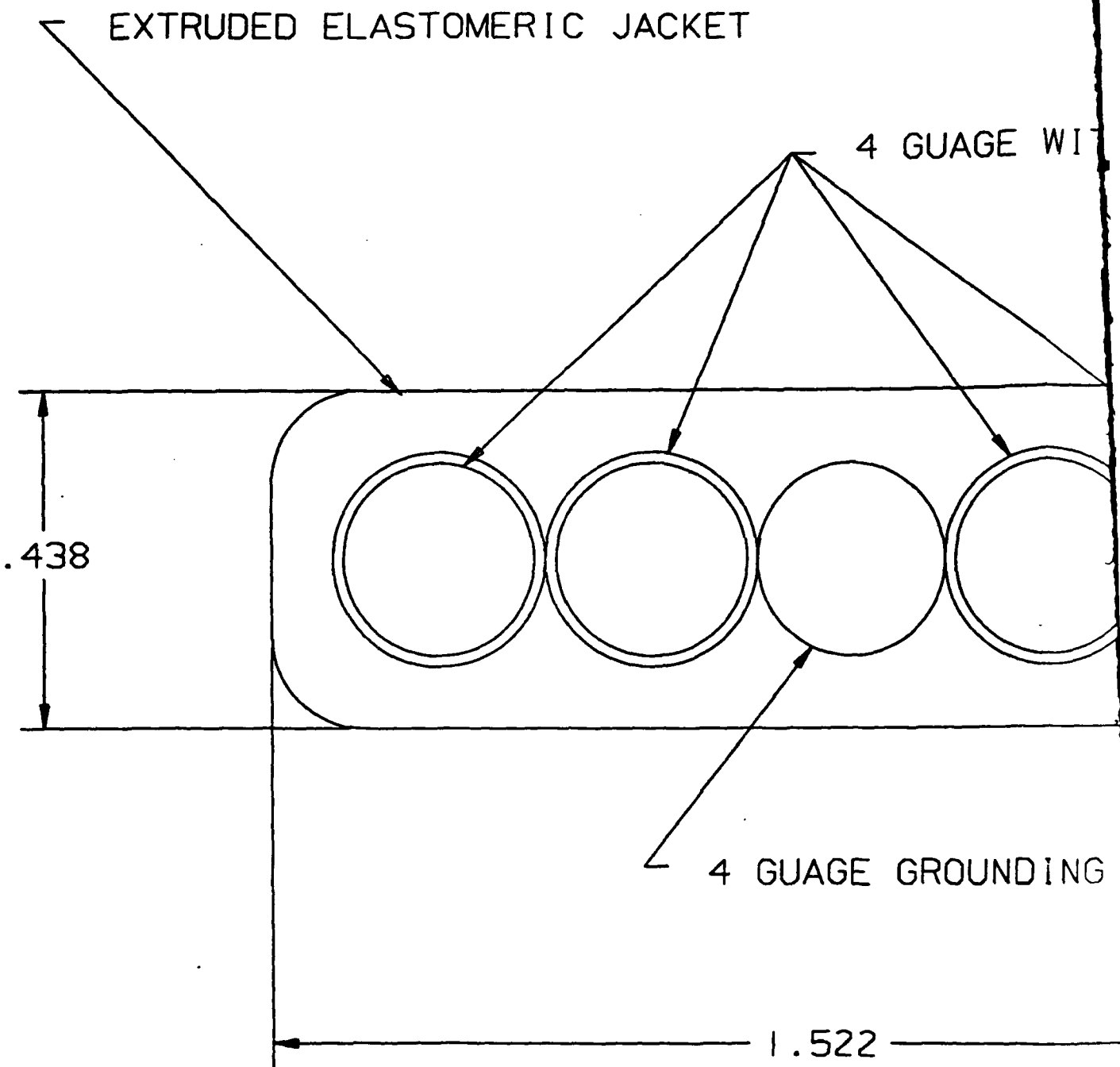

120/240V 60AMP 3-PHASE

GE WITH TFE INSULATION 1000V

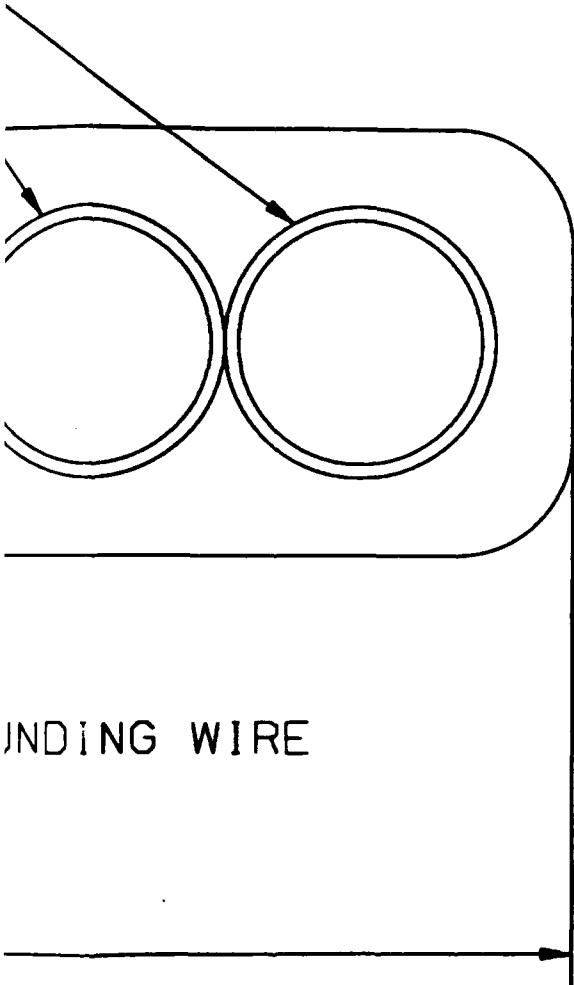

WINDING WIRE

CHASE FLAT CABLE

EXTRUDED ELASTOMERIC JACKET

1 GAUGE WIRE

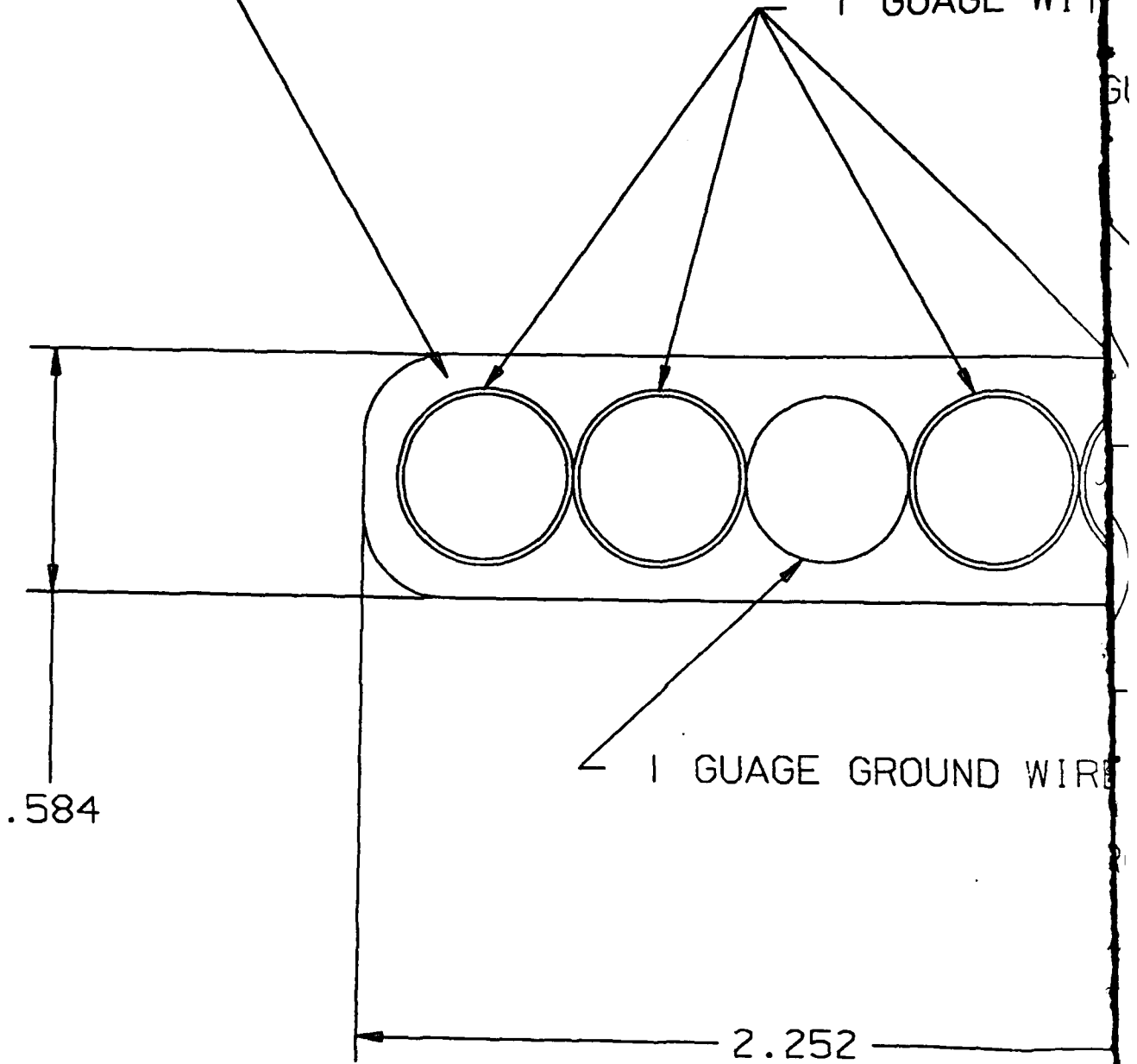

.584

1 GAUGE GROUND WIRE

2.252

120/240V 100AMP 3-PHASE

GE WITH TFE INSULATION 1000V

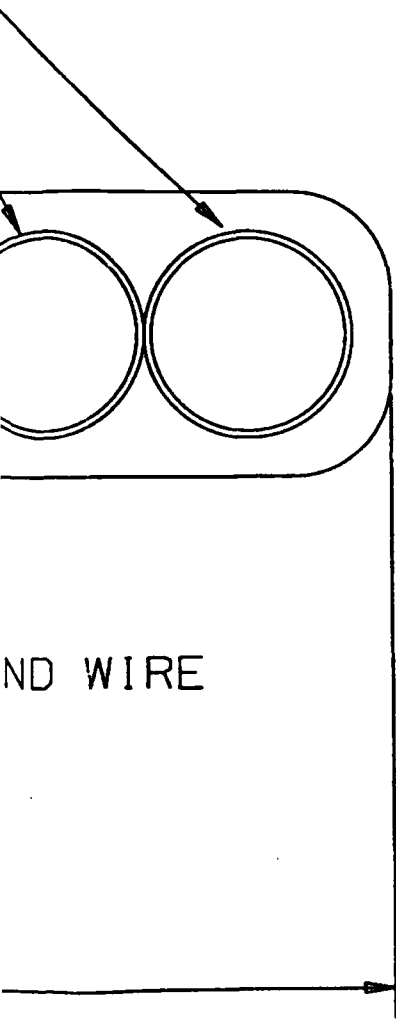

PHASE FLAT CABLE

1

2

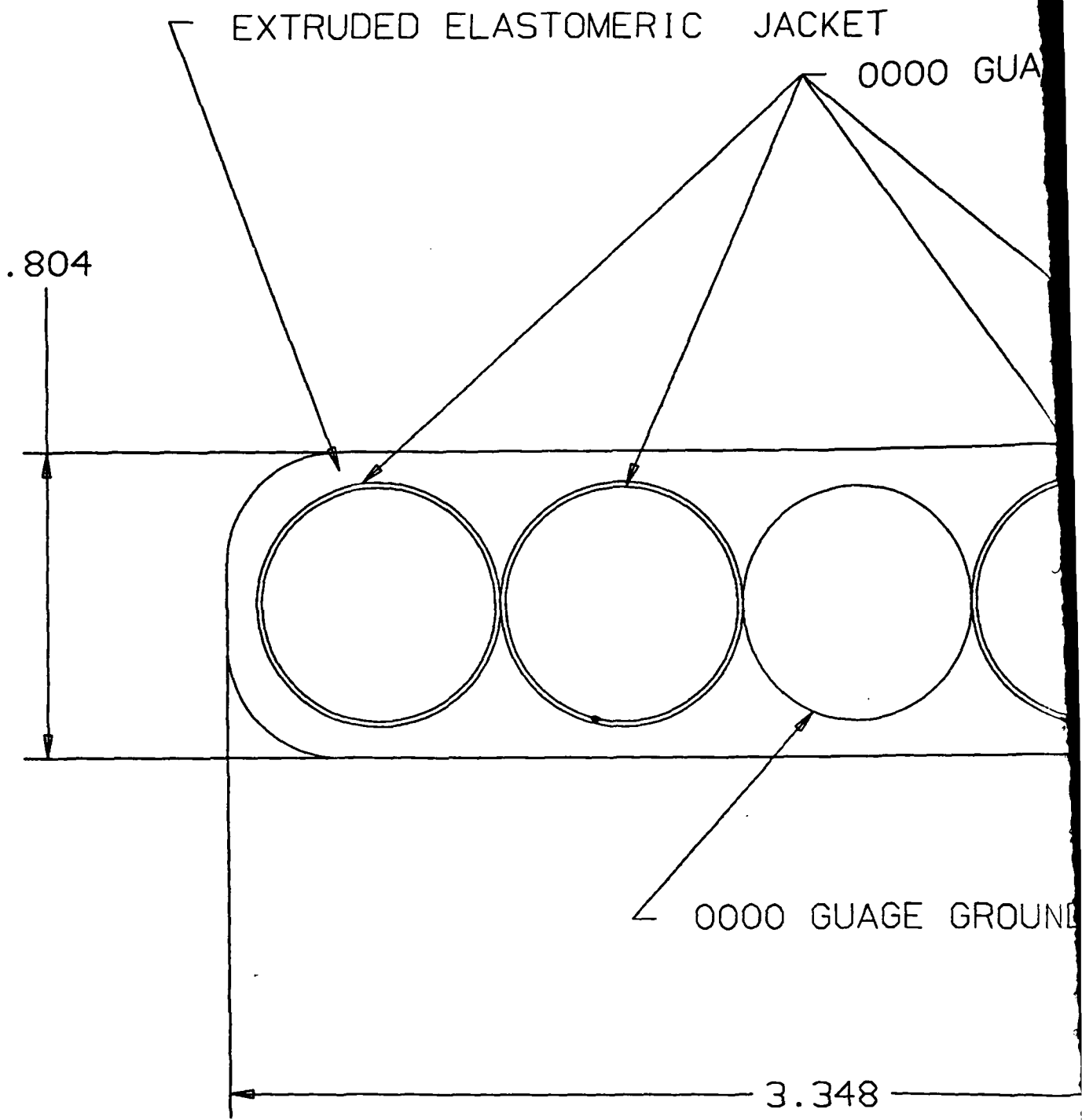

120/240V 200AMP 3-PHASE

000 GAUGE WITH TFE INSULATION 1000V

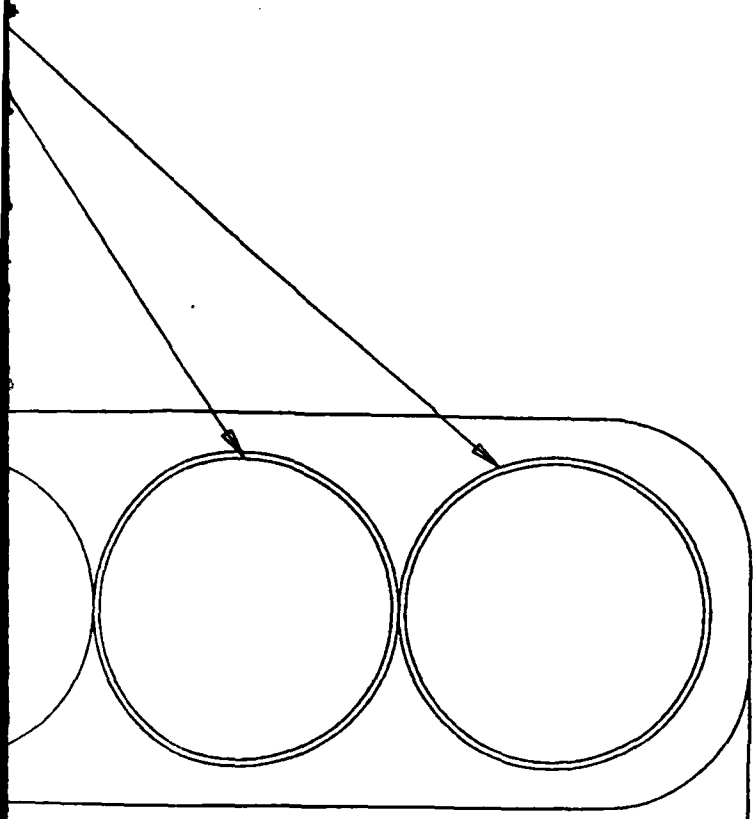

E GROUND WIRE

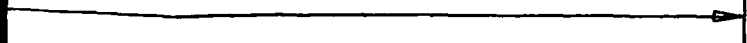

PHASE FLAT CABLE

1

2

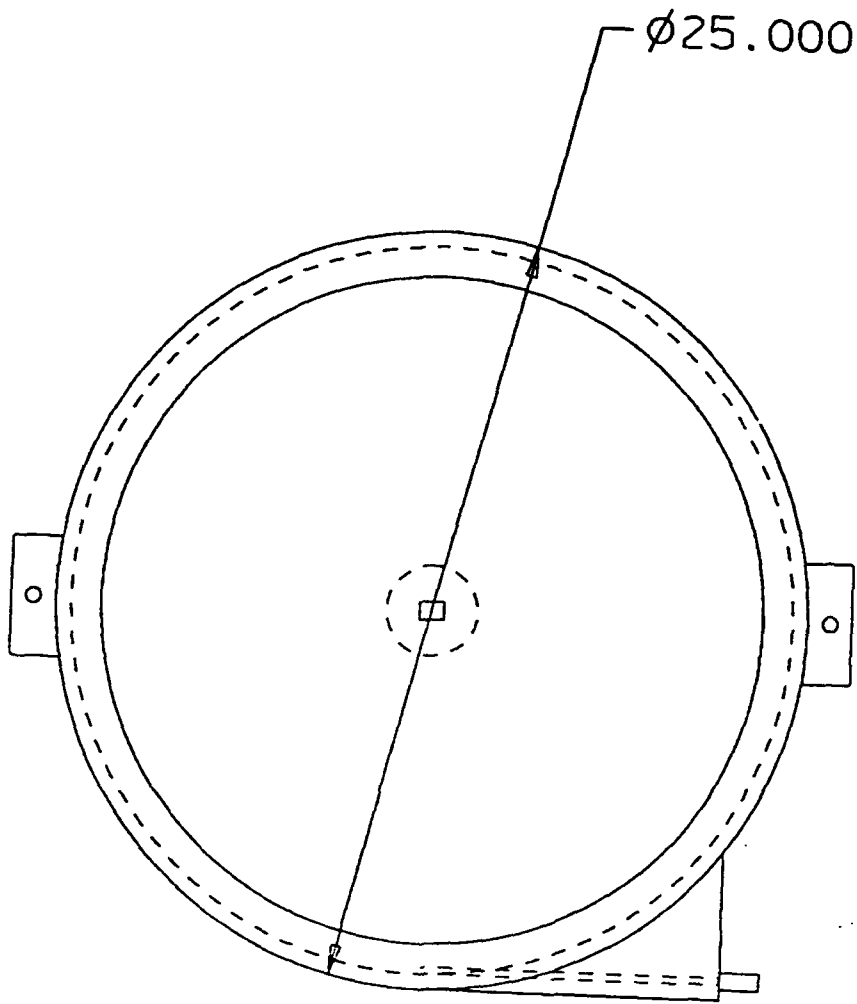

120/240V 20AMP 1-PHASE

1

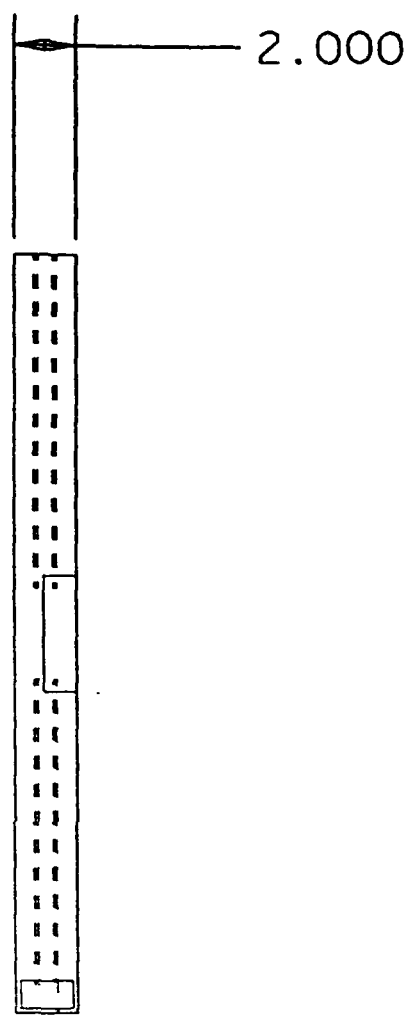

2.000

PHASE REEL SINGLE ROW

1

2

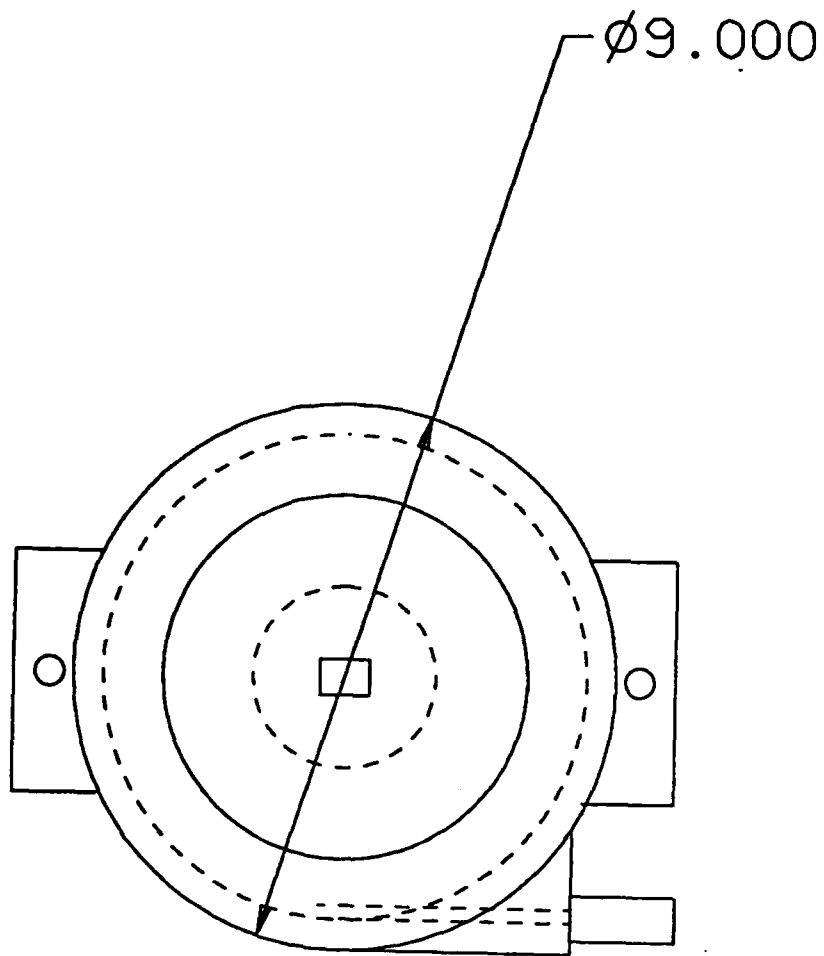

120/240V 20AMP 1-PHASE F

1

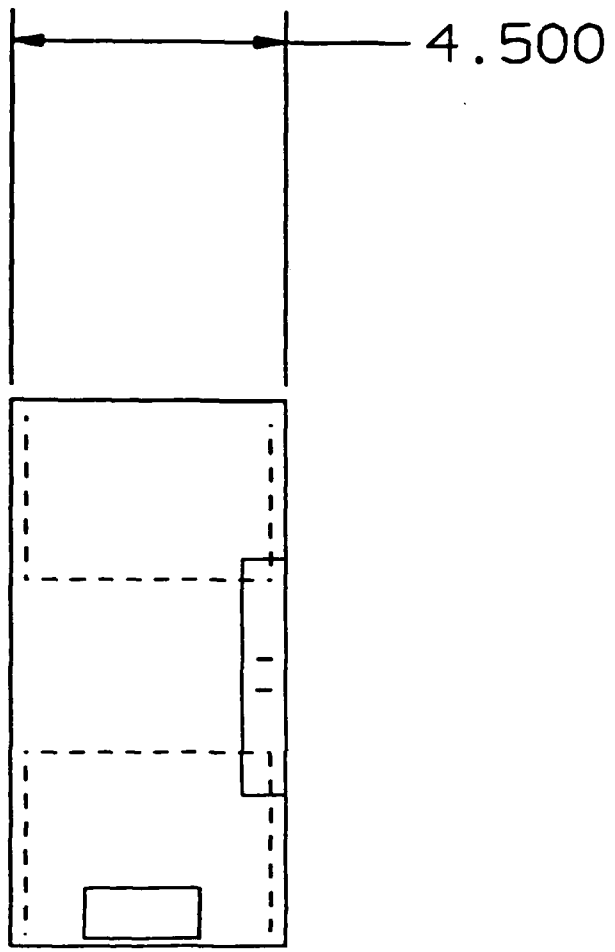

ASE REEL RANDOM WOUND

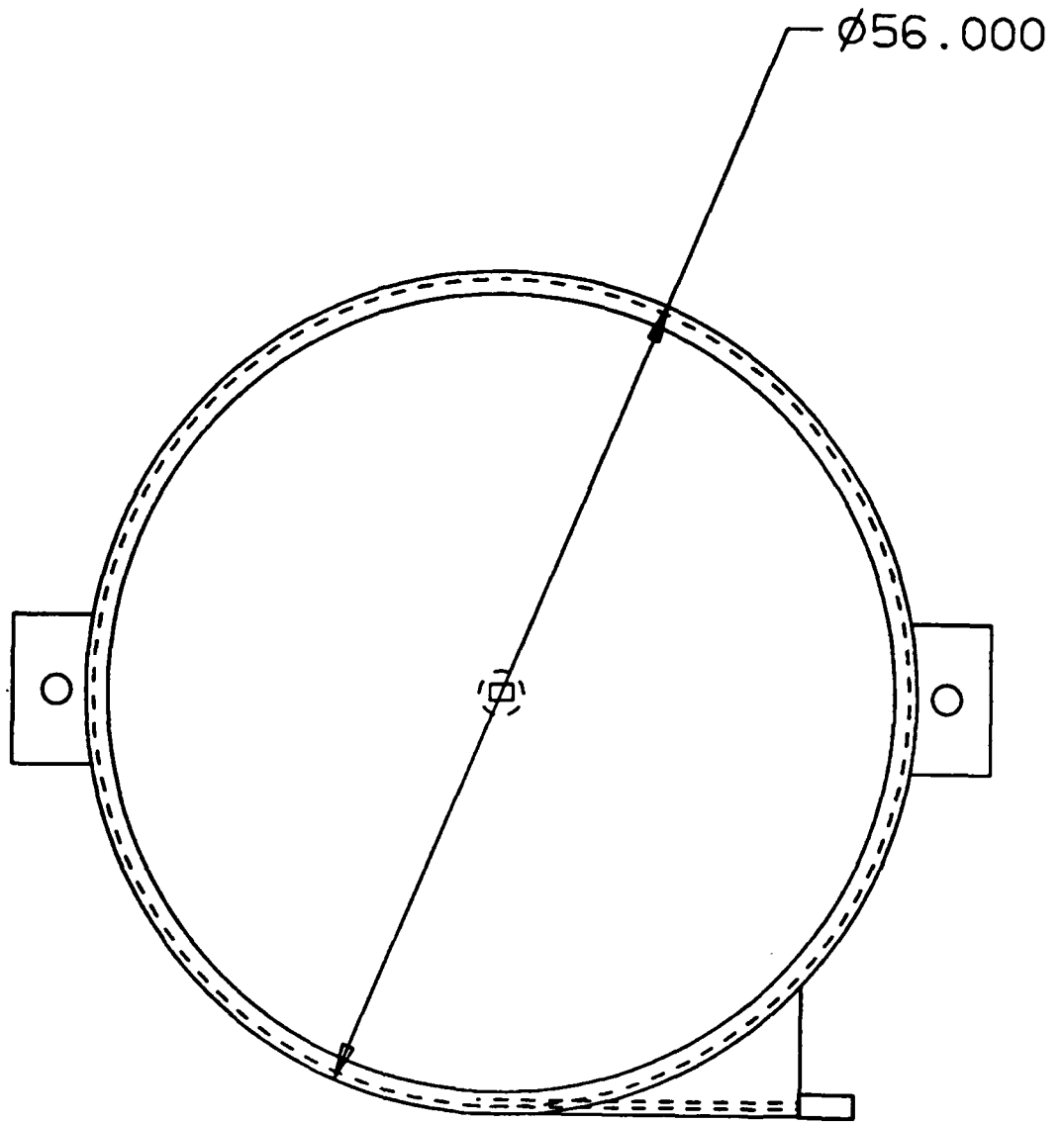

120/240 60AMP 3-PH

1

000

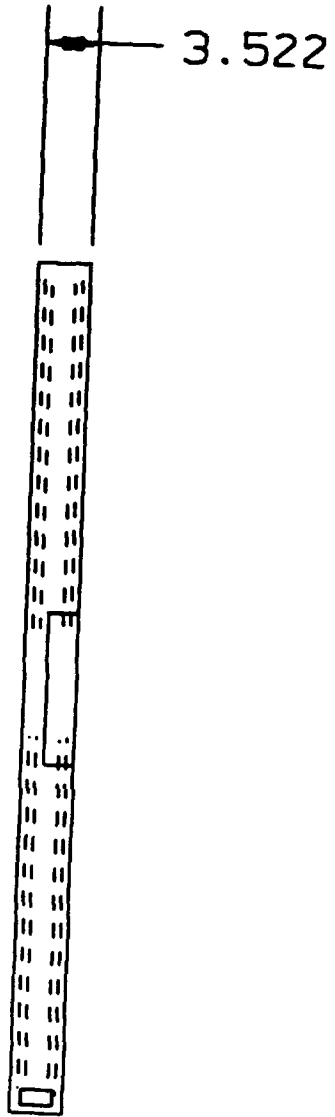

3-PHASE REEL

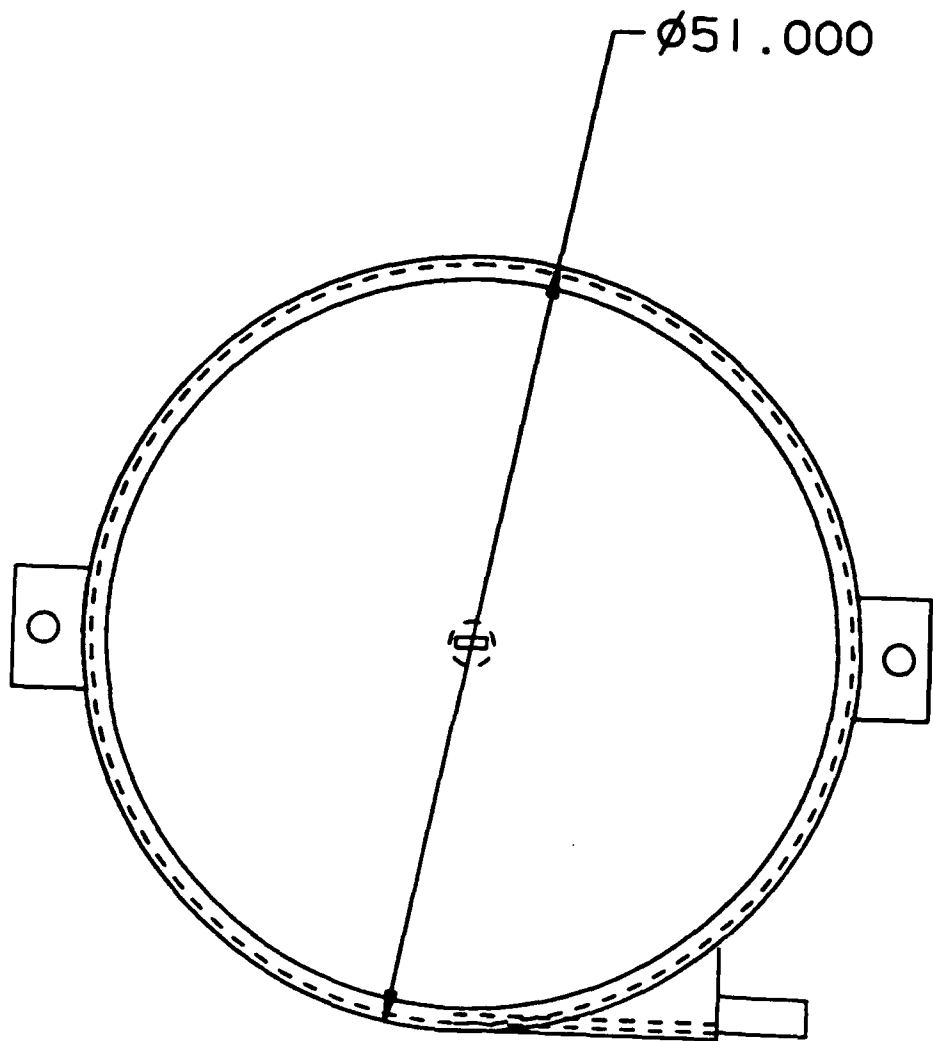

120/240V 100AMF

1

00

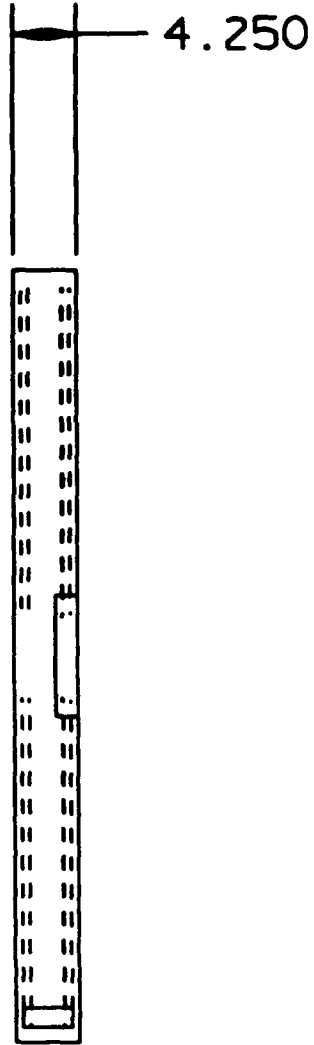
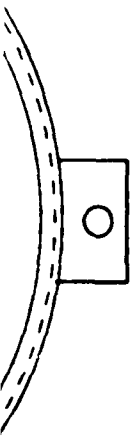

100AMP 3-PHASE REEL

1

A handwritten signature or mark, possibly a stylized 'R' or '2', located at the bottom right of the page.

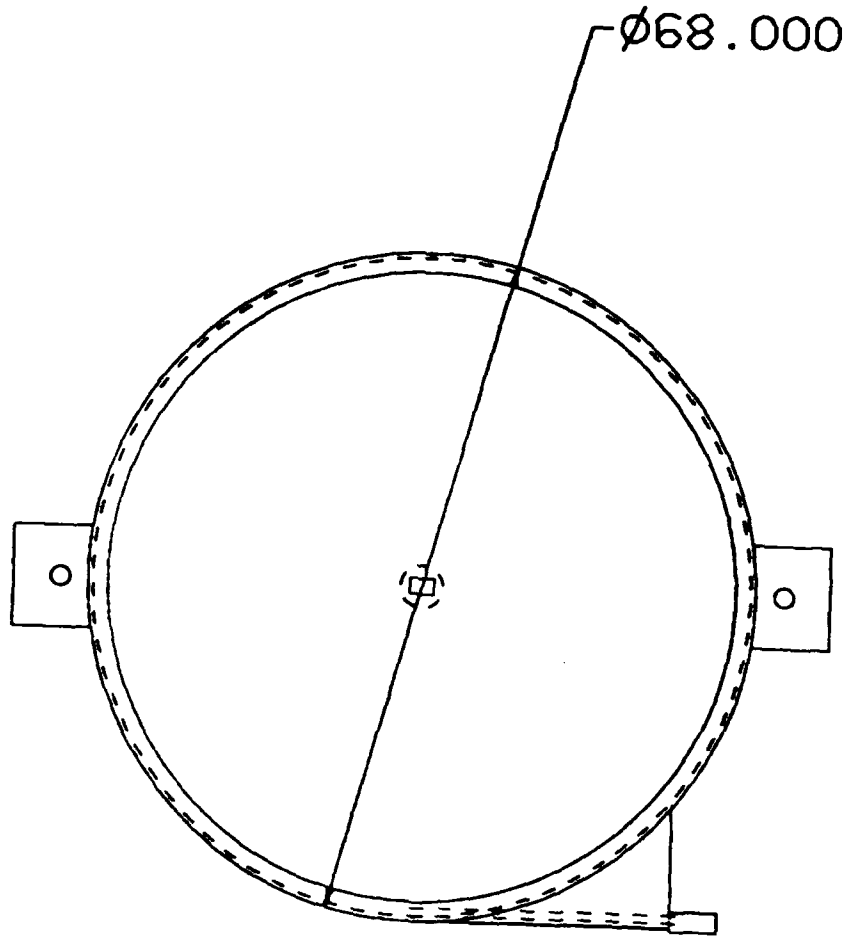

120/240V 20

1

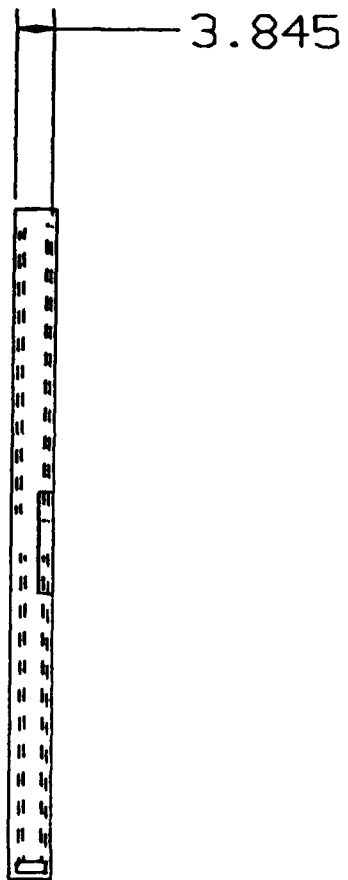

0V 200AMP 3-PHASE REEL

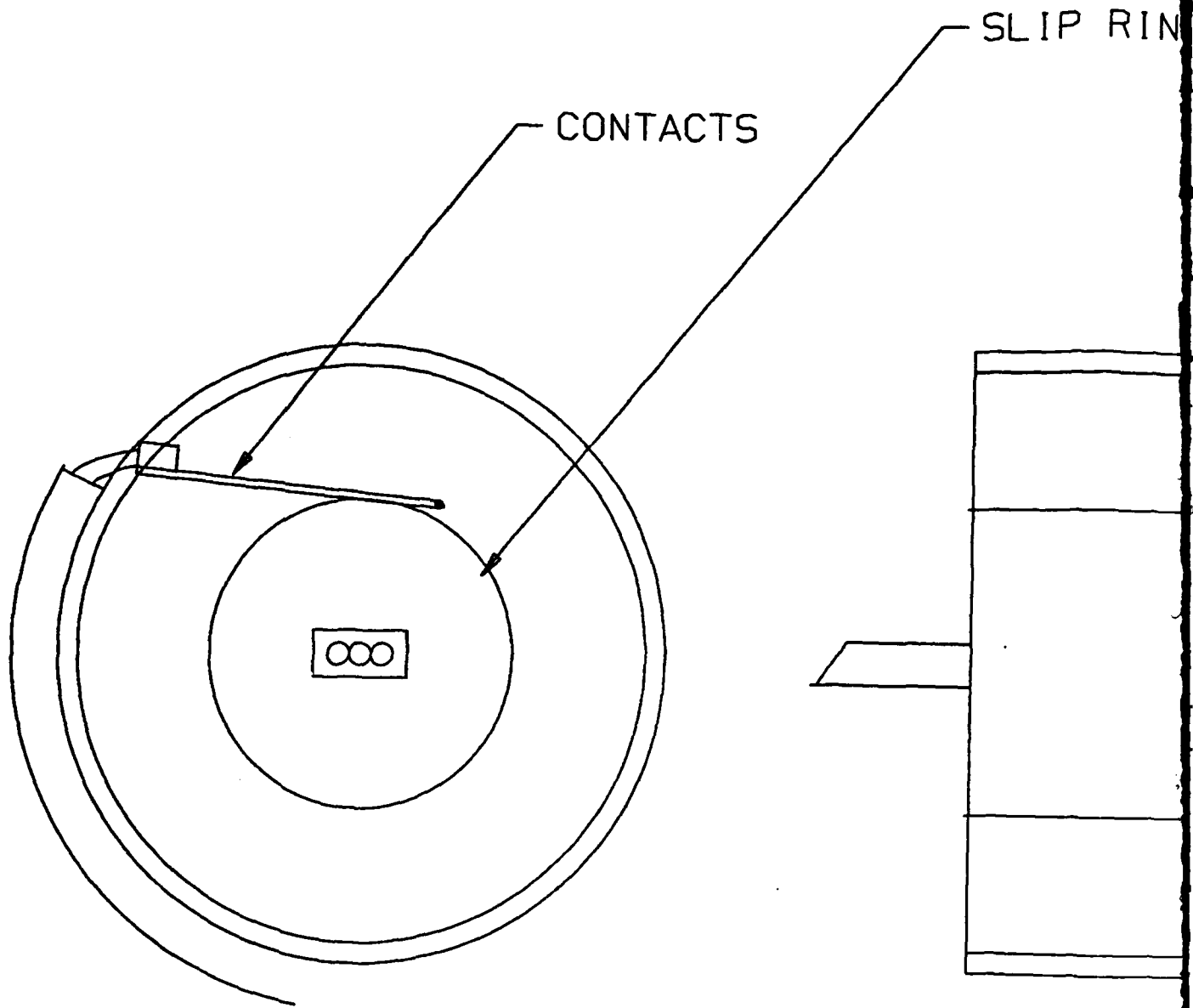

SLIP RING DETAIL ON

1

LIP RINGS

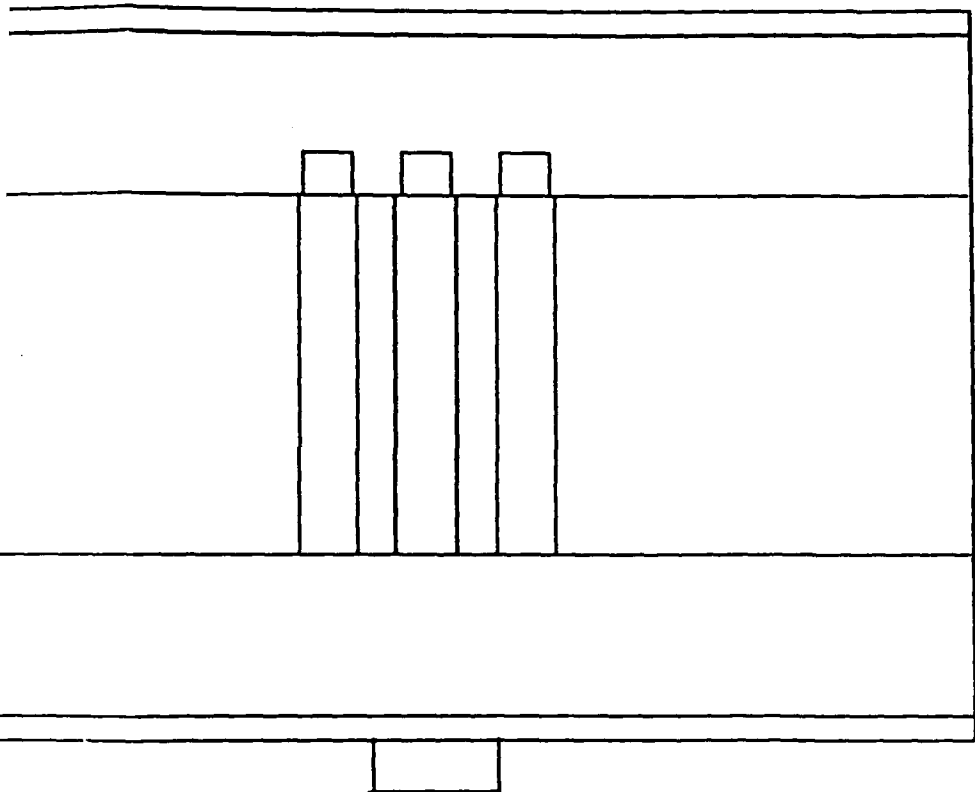

IL ON REELS

1

2

## CONNECTOR DESIGN

The design of the connectors is conceptually similar to the extremely successful modular jack connector used in telecommunications and computer applications. Like the modular jack the connector mass terminates to a flat cable and involves a positive latch to attach the connectors. This is far superior in ease of use and durability to the jackscrews commonly used in rectangular profile connectors, as well as to threaded circular connectors. Unlike the modular jack however these connectors have to be splash and moisture proof and withstand more severe environments. To achieve these ends the connector concepts employs spring loaded doors which are normally closed to prevent moisture or dirt from entering the connector when unmated. These are similar in concept to those used in 3 1/2" floppy disc technology for the male, or to cassette players for the female. These approaches have shown their practicality in actual use as well as their potential for economical manufacture. Current generation cylindricals use dust covers attached by a chain, this slows deployment/redeployment, and if the dust cover is forgotten or ignored damaging material can enter the connector. Waterproof sealing of mated connectors is provided with an elastomeric face seal between the male and female connectors. Sealing between the cable and connector body is accomplished by multiple v edge pressure seals and strain reliefs in the connector. If compatible materials are used a hermetic ultrasonic weld could also be accomplished when the connector is assembled.

The contact contact mating surfaces of the contacts in this system

would be gold or gold alloy in sufficient thickness to withstand 30 years of use. The use of contacts formed from strip leads to the practical application of selective plating or inlay to greatly reduce cost compared to barrel plated cylindrical contacts. Gold surfaces have much higher reliability and environmental stability than the silver contacts used in 229 series connectors which quickly sulfide under field conditions.

The contacts have been designed from alloy C155 00 which offers 86% minimum conductivity, high softening resistance, and a tensile strength of 65,000, and a yield strength of 62,000 psi. This material like many high conductivity alloys is only available in strip, and offers superior conductivity as well as much lower cost than beryllium copper commonly available in screw machine contacts. Contacts were analyzed for the 60 amp 3 phase size and a material thickness of .040" was selected which gives a contact cross sectional area equal to the wire diameter. The contacts design provide a nominal force per contact of 1200 grams, or since the design is trifurcated 400 grams per contact point. The trifurcated design minimizes contact resistance and maximizes reliability.

Several case materials were analyzed for the connector body. Objectives were, capability to hold tight tolerances on large parts, high impact resistance, low shrinkage to minimize molded in stress, low notch sensitivity to maintain good impact strength in areas of section change and or sharp corners, good resistance to gasoline, motor oil, naphtha etc. Among the most common connector material are nylon 6/6, PBT, PET, DAP and PPS, all of these materials however suffer from low notched izod impact strength, and

the thermoplastics while exhibiting good solvent resistance have high and anisotropic shrinkage causing warpage and making dimension difficult to control in large parts. The materials analyzed include Mindel Polysulfone/PET alloys, Ultem Polyether-imide, Noryl GTX Polyphenelene Ether/Nylon alloys. Typical critical properties are listed below.

<u>Material</u>	<u>Mindel 650</u>	<u>Ultem 2200</u>	<u>Noryl GTX 830</u>
tensile strength	7,300	20,100	23,000
notched izod impact	9.5	1.6	2.0
shrinkage flow in/in	.0066	.0040	.0040
shrinkage traverse in/in	.0066	.0030	.0060
solvent resistance	excellent	excellent	excellent
HDT 264 psi °F	302	408	455

Based on its superior notched impact strength, and low isotropic shrink rate the Polysulfone/PET alloy was selected for the connector housing.

The connector housing is designed for assembly thru ultrasonic welding, providing maximum strength as well as watertightness. Termination would be factory performed using mass termination on crimping dies with locating fixtures.

The 60 amp 3 phase size was selected for detailed layouts which follow.

← SPRING LOADED DOOR

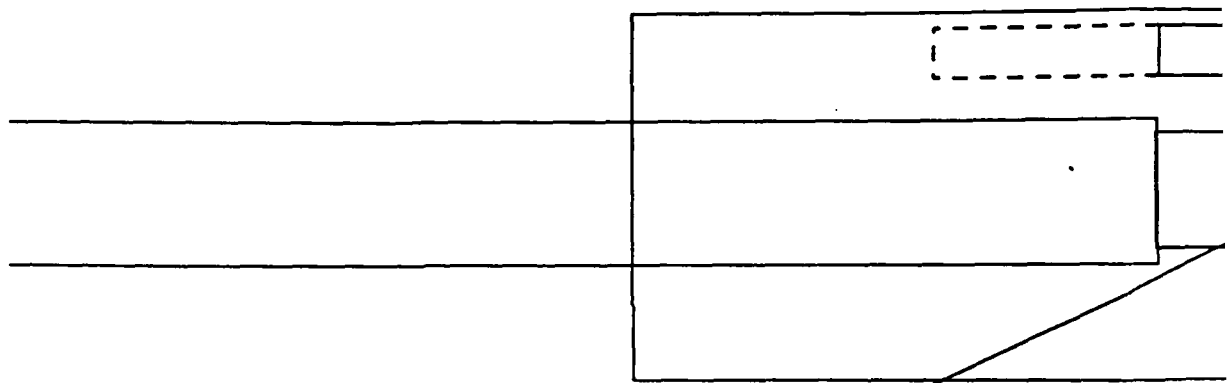

← CRIMP TERMINATED CONTACTS

MALE CONNECT

1

SHUTTERED DOOR

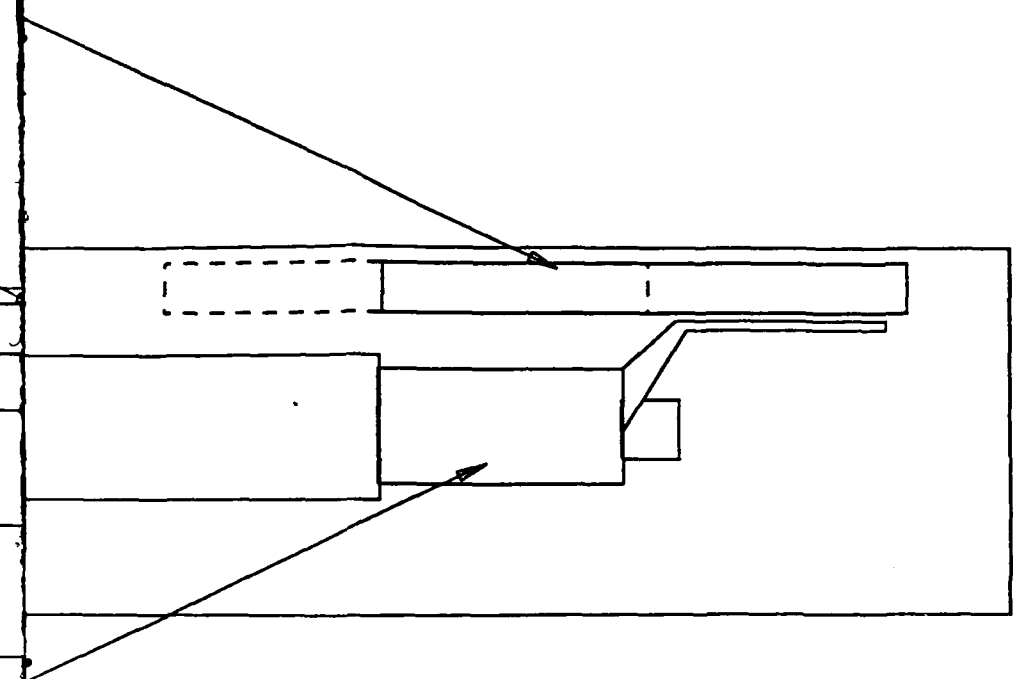

TERMINATED CONTACTS

THE CONNECTOR CONCEPT

1

2

← SPRING LOADED DOOR

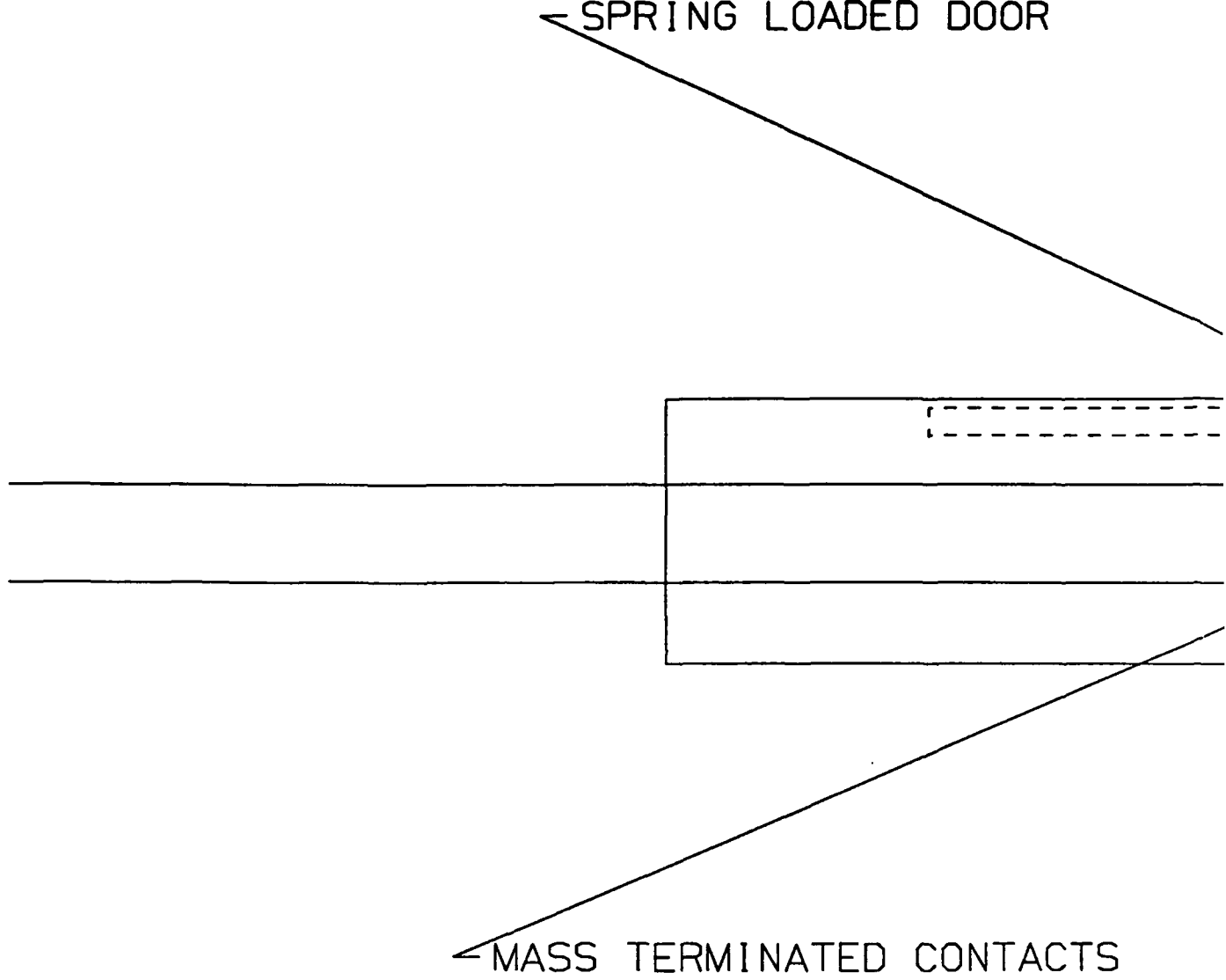

← MASS TERMINATED CONTACTS

MALE CONNECTOR C

1

LOADED DOOR

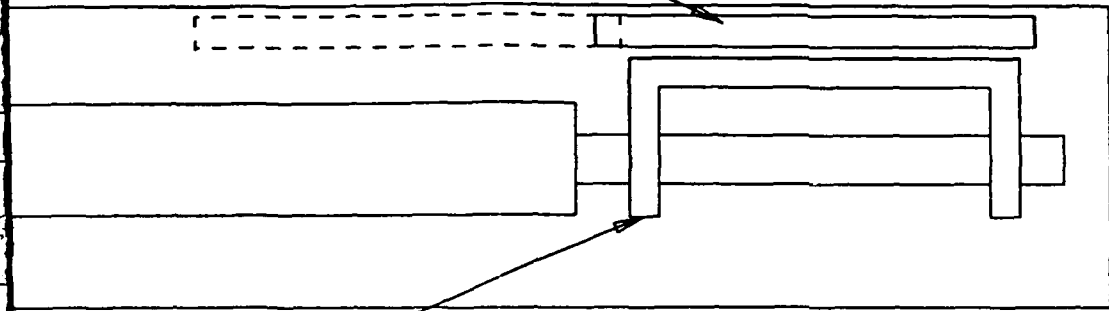

SEPARATED CONTACTS

CONNECTOR CONCEPT

2

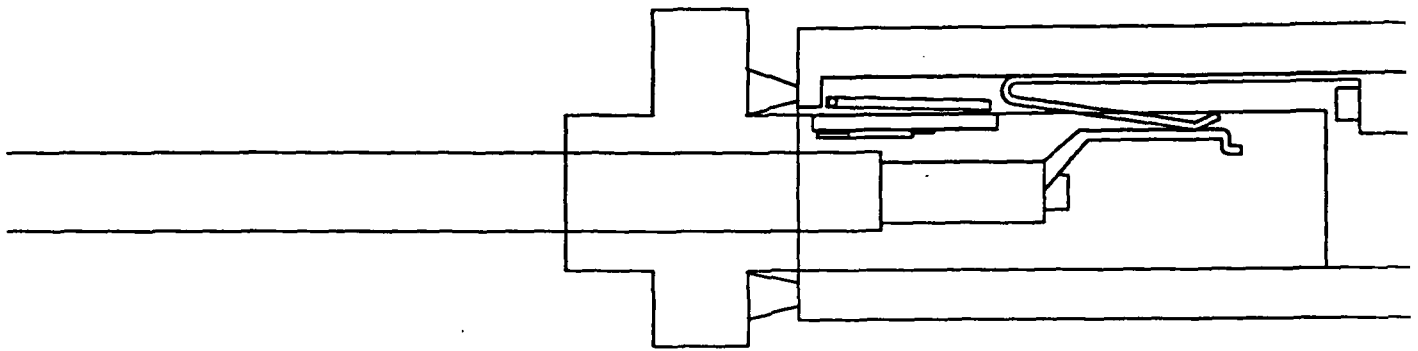

ASSEMBLED CONNECTOR

1

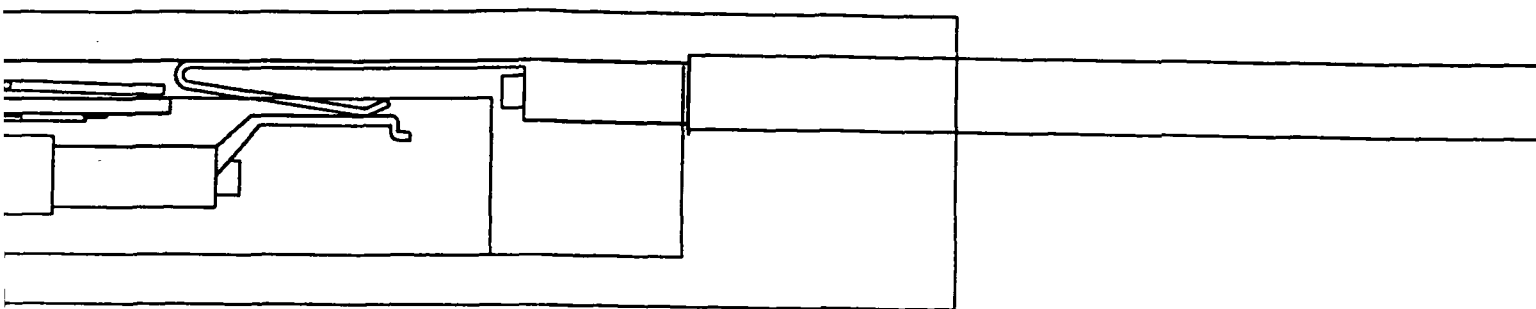

ED CONNECTORS CONCEPT

1

1

2



A technical drawing showing a cross-section of a connector latch and seal assembly. On the left, a vertical component features a circular seal. This seal is positioned against a horizontal surface of a larger assembly on the right. A dashed line indicates a hidden internal feature of this assembly. A diagonal line with an arrowhead points from the text 'FACE SEAL' to the circular seal. The assembly on the right has a hatched section at the point of contact with the seal. Below the main assembly, there are two vertical lines extending downwards.

← FACE SEAL

CONNECTOR LATCH AND SEAL

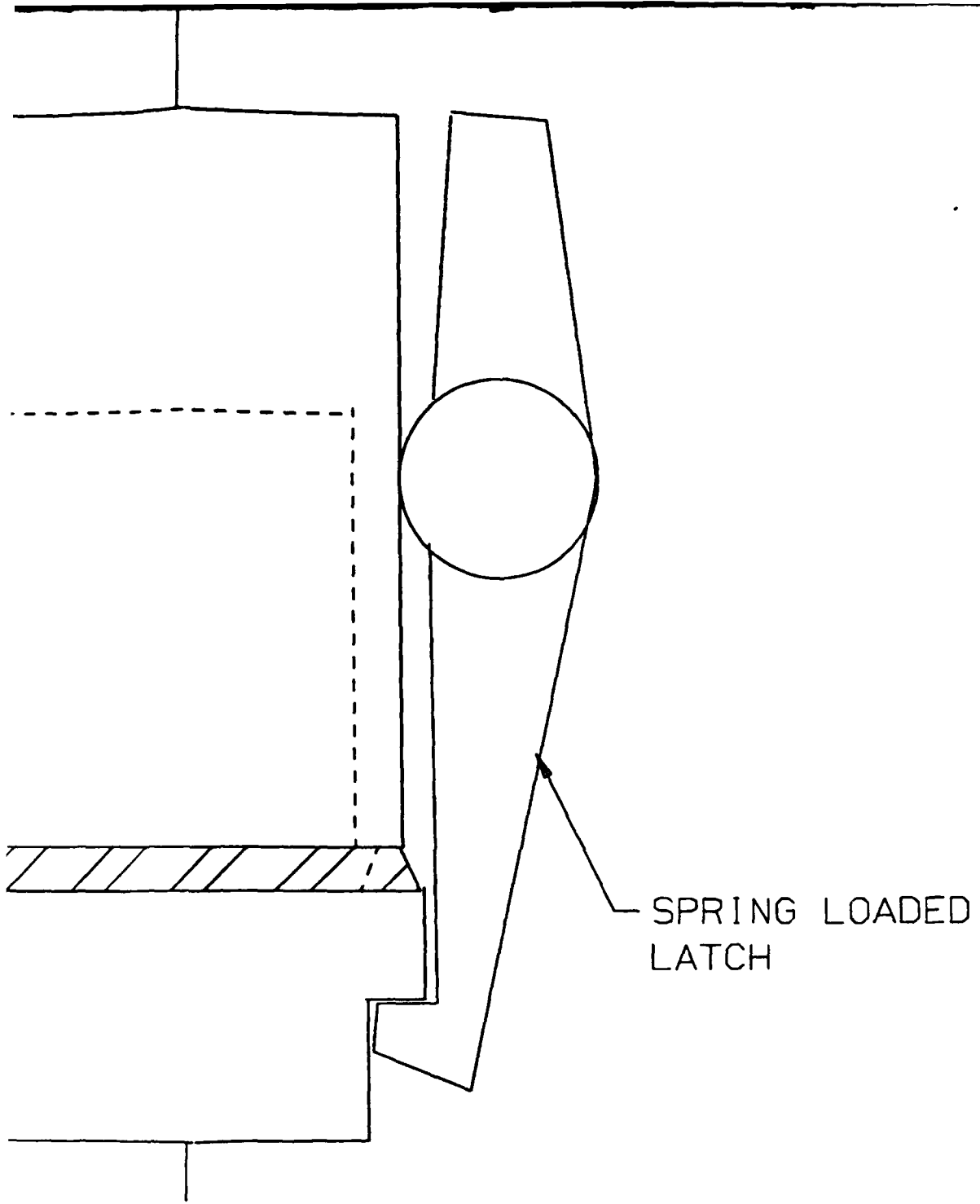

SPRING LOADED  
LATCH

4 AND SEAL CONCEPT

1

2

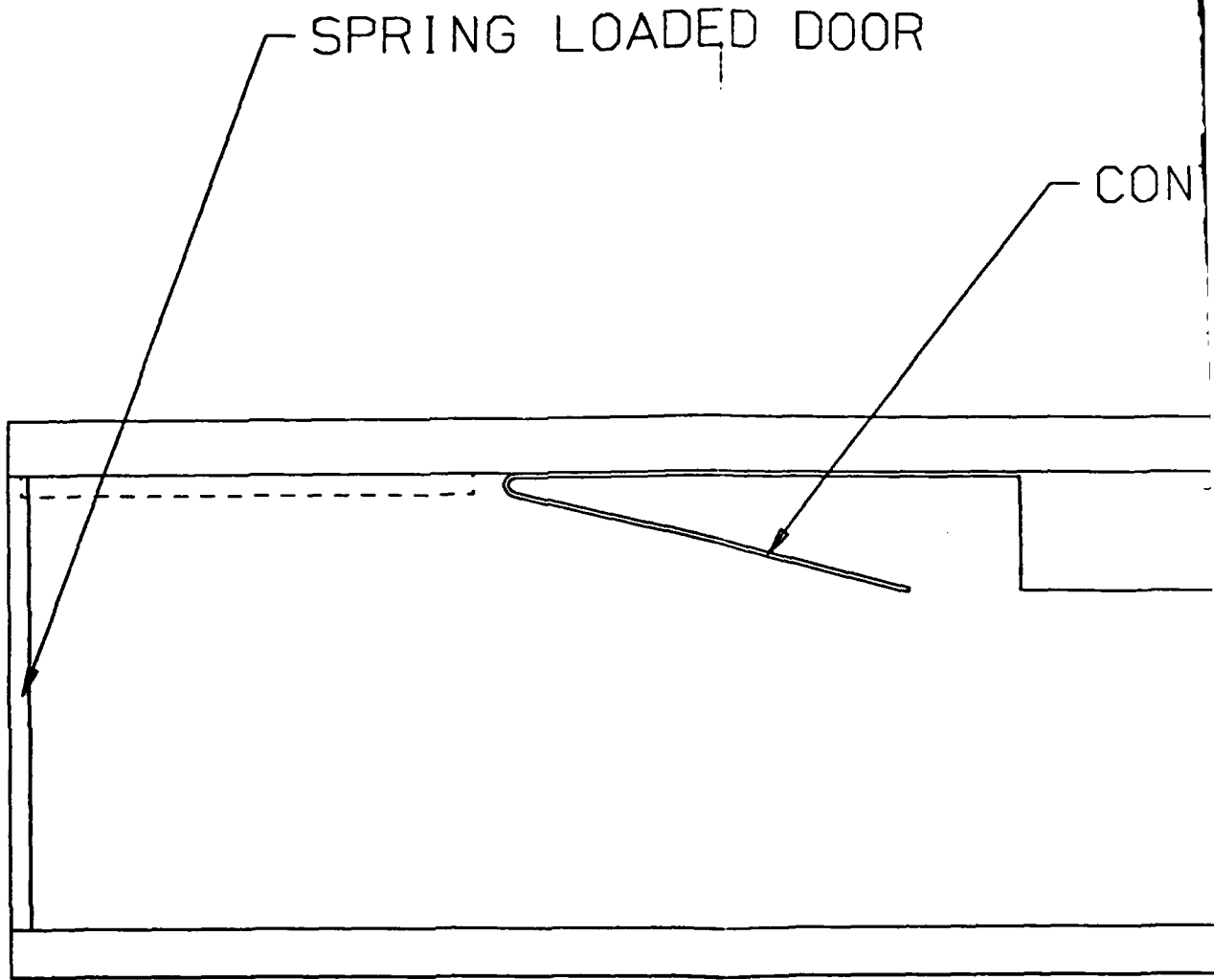

FEMALE CONNECTOR CONC

1

DED DOOR

CONTACTS

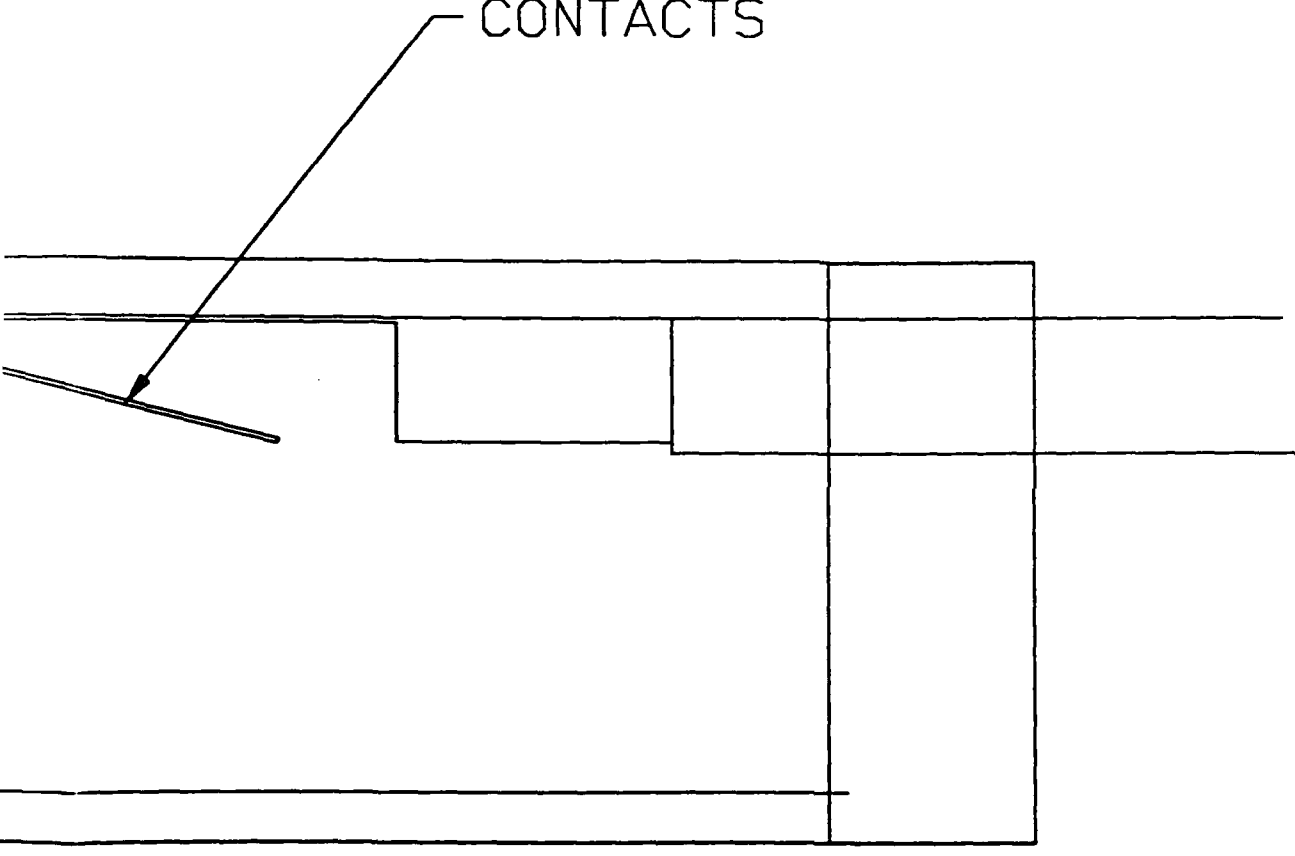

CONNECTOR CONCEPT

1

2

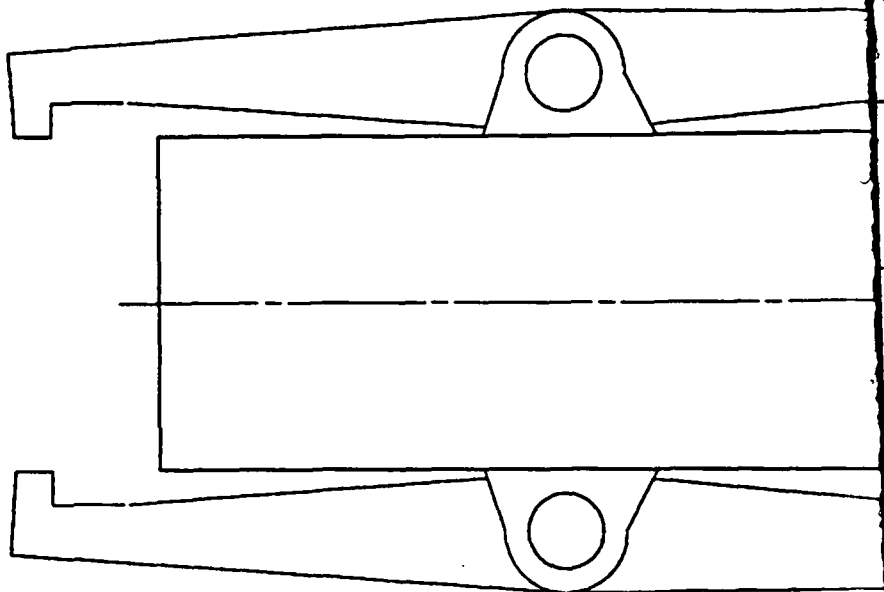

120/240V 60 AMP 3 PHASE FEMALE

TOP

1

174

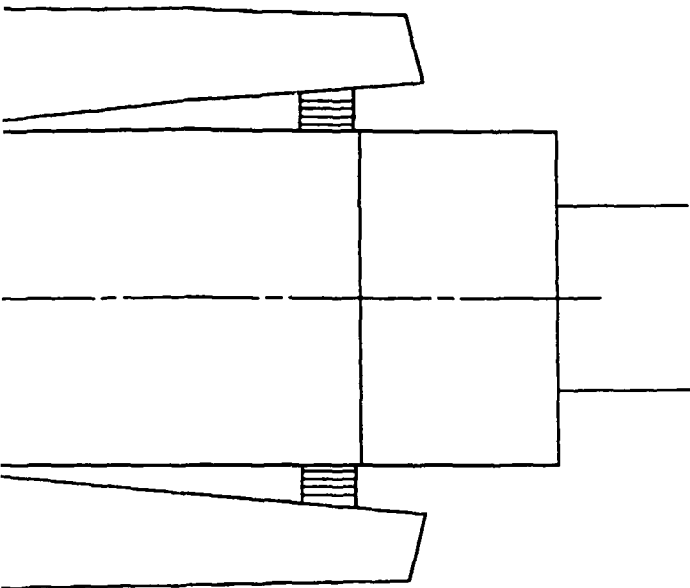

FEMALE CONNECTOR LAYOUT

—

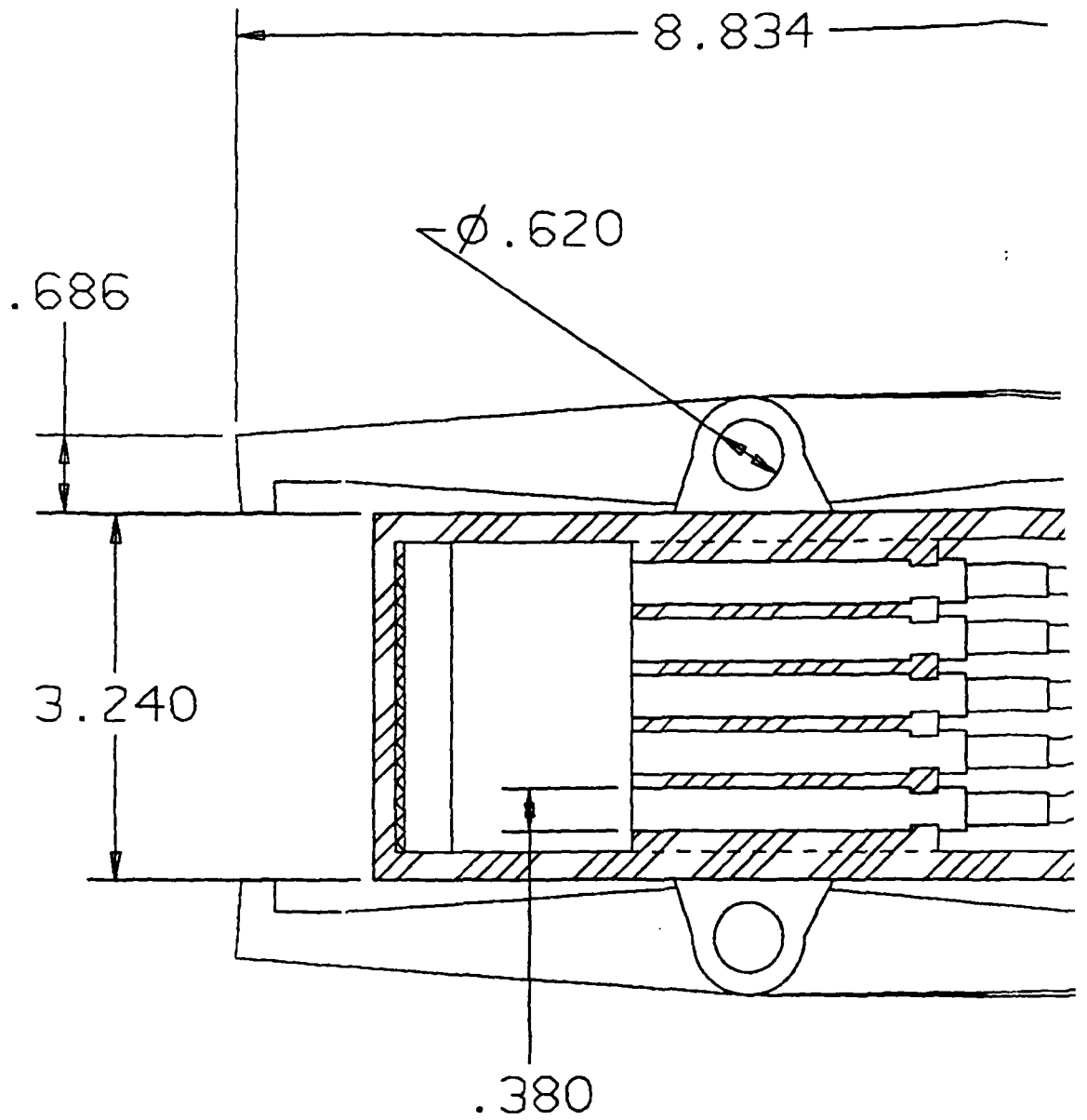

120/240V 60 AMP 3 PHASE FEMALE CONNE

TOP

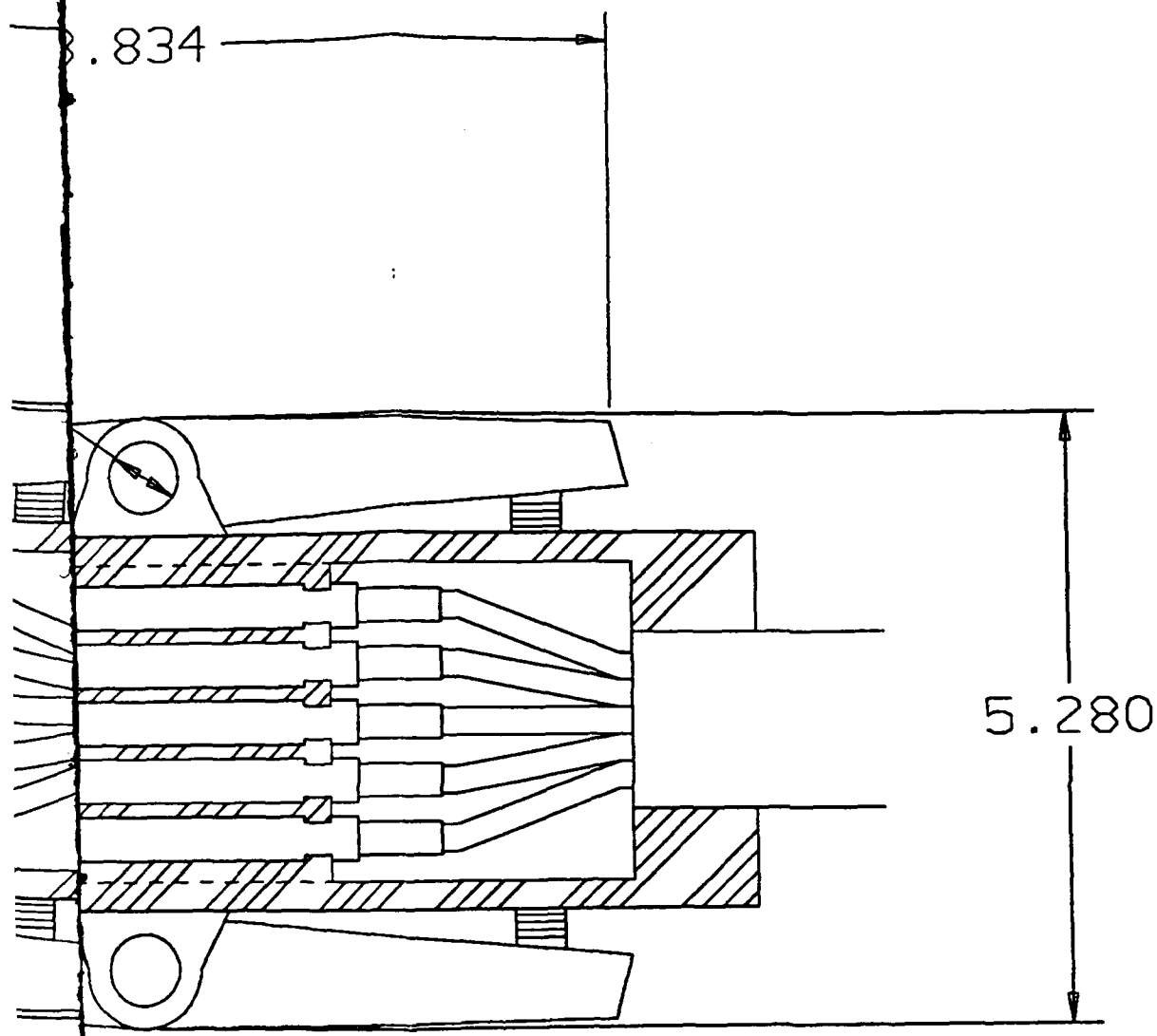

OFFEMALE CONNECTOR LAYOUT DIMENSIONED

1 i a

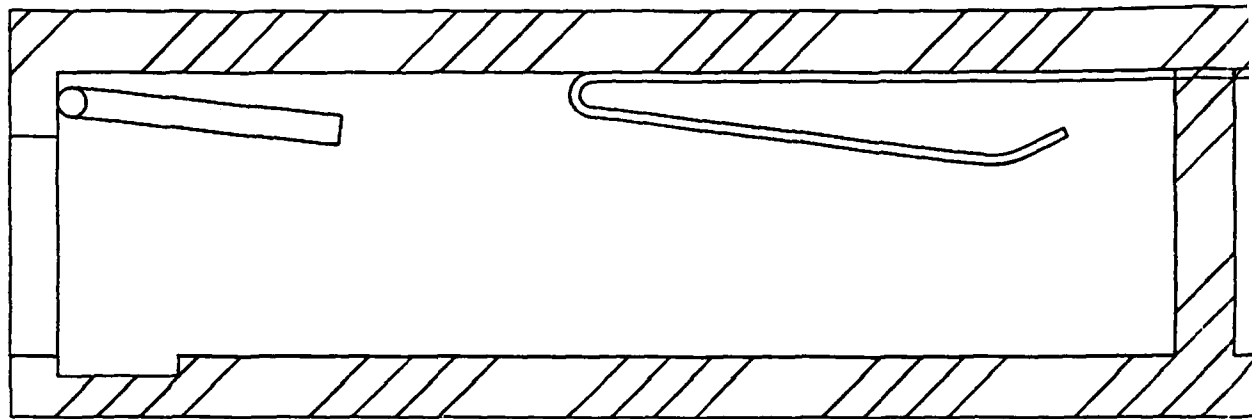

120/240V 60AMP 3PHASE FEMAL  
CONTACTS AND DUST COVER

SIDE

1

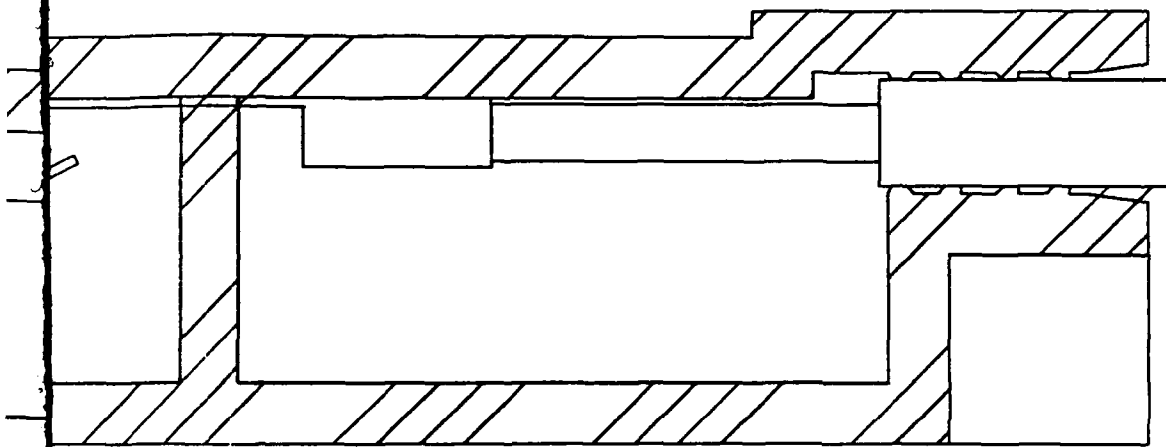

FEMALE CONNECTOR LAYOUT  
SH OVER SHOWN DEFLECTED

1

2

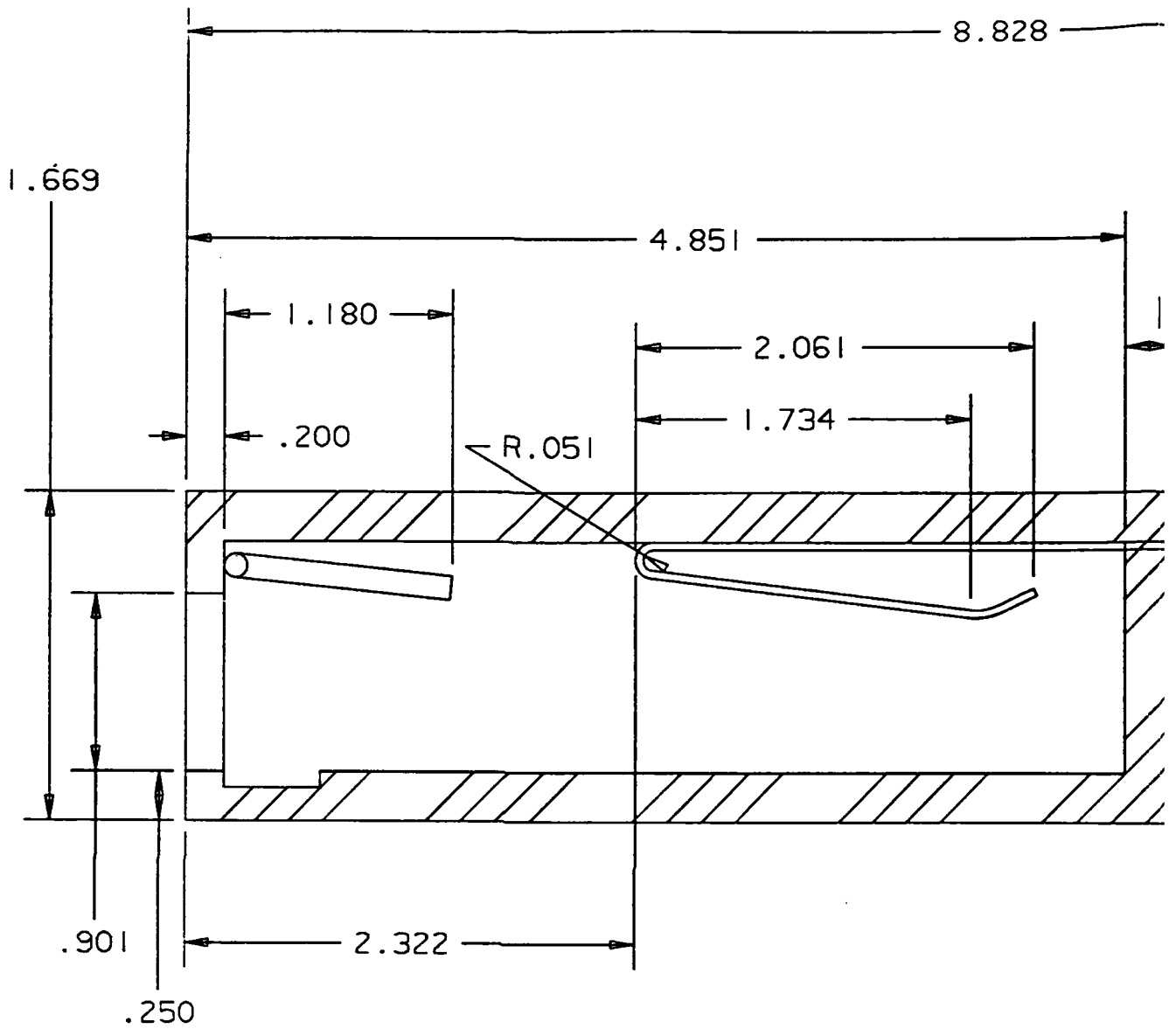

120/240V 60AMP 3PHASE FEMALE CON  
 CONTACTS AND DUST COVER SHC  
 SIDE

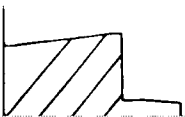

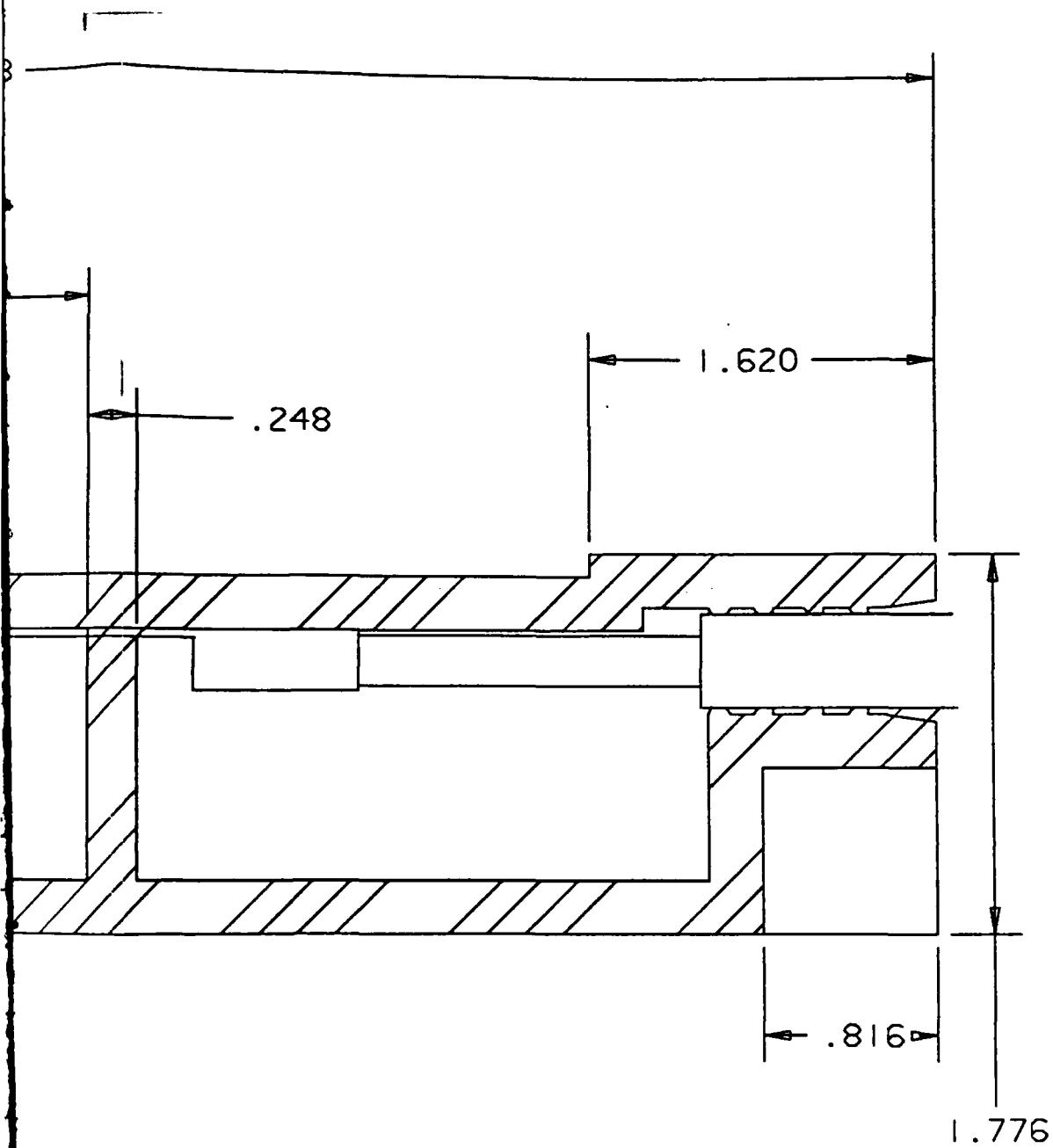

CONNECTOR LAYOUT DIMENSIONED  
SHOWN DEFLECTED

1

2

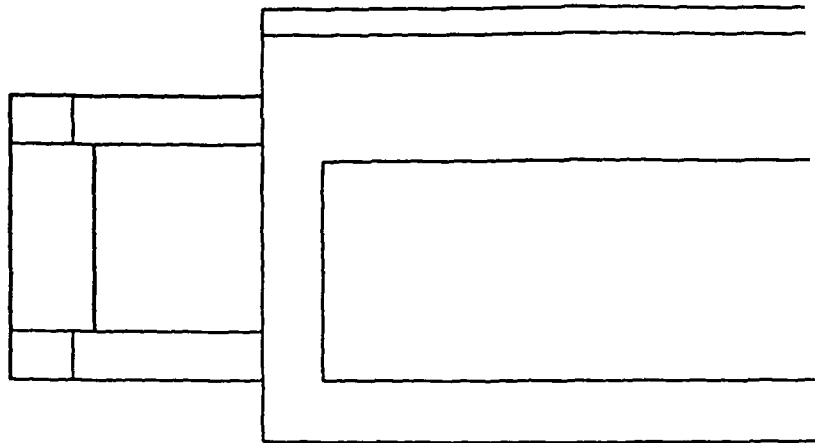

120/240V 60 AMP 3 PHASE FEM

FRONT

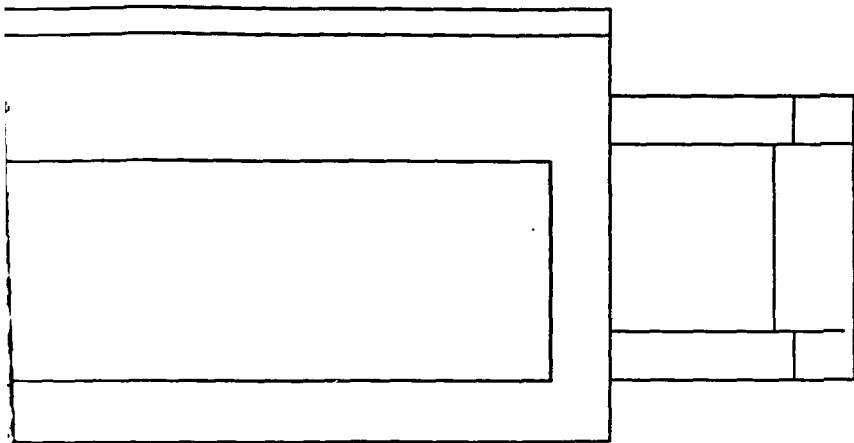

3 PHASE FEMALE CONNECTOR LAYOUT

2

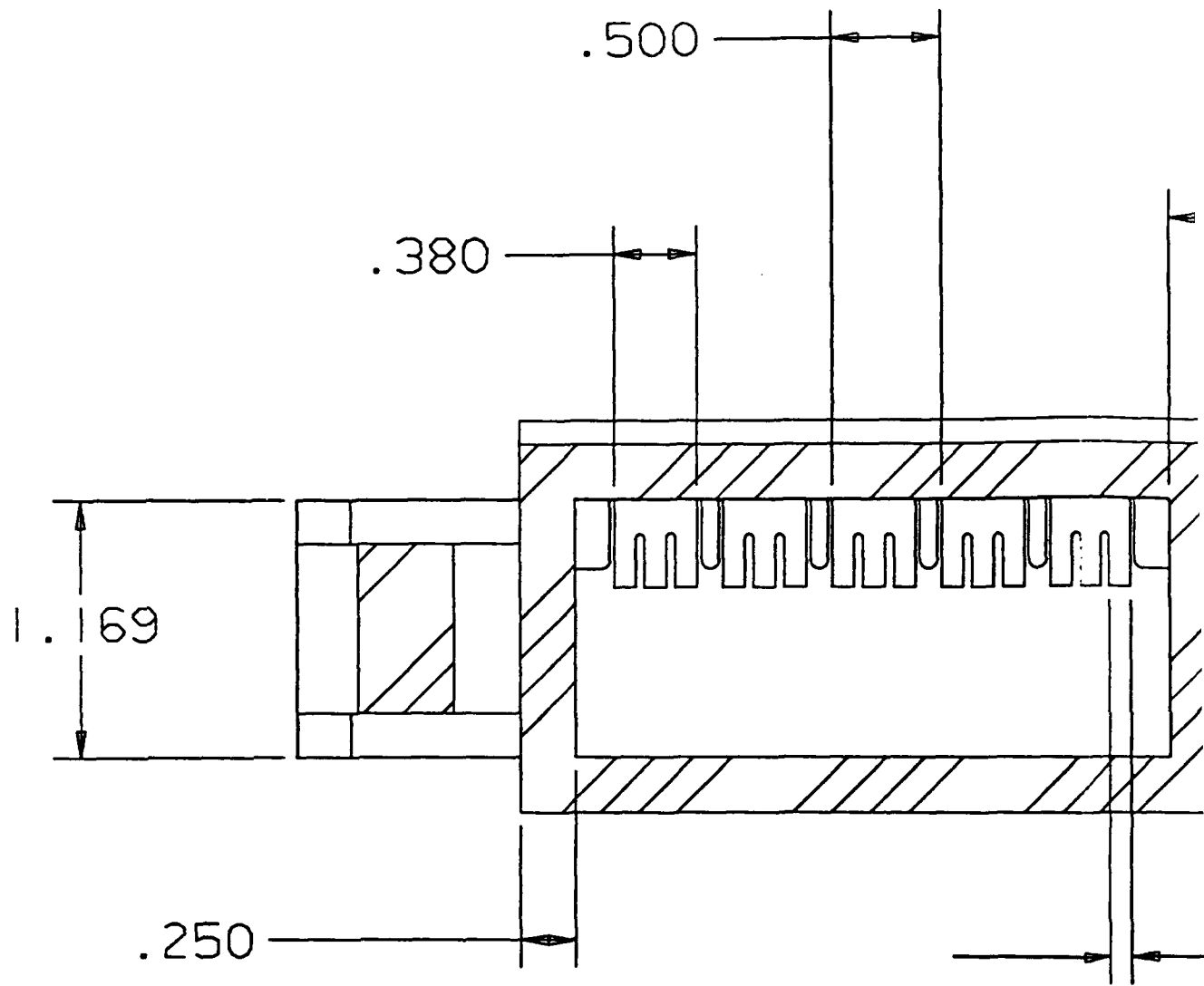

120/240V 60 AMP 3 PHASE FEMALE CONNECT

FRONT

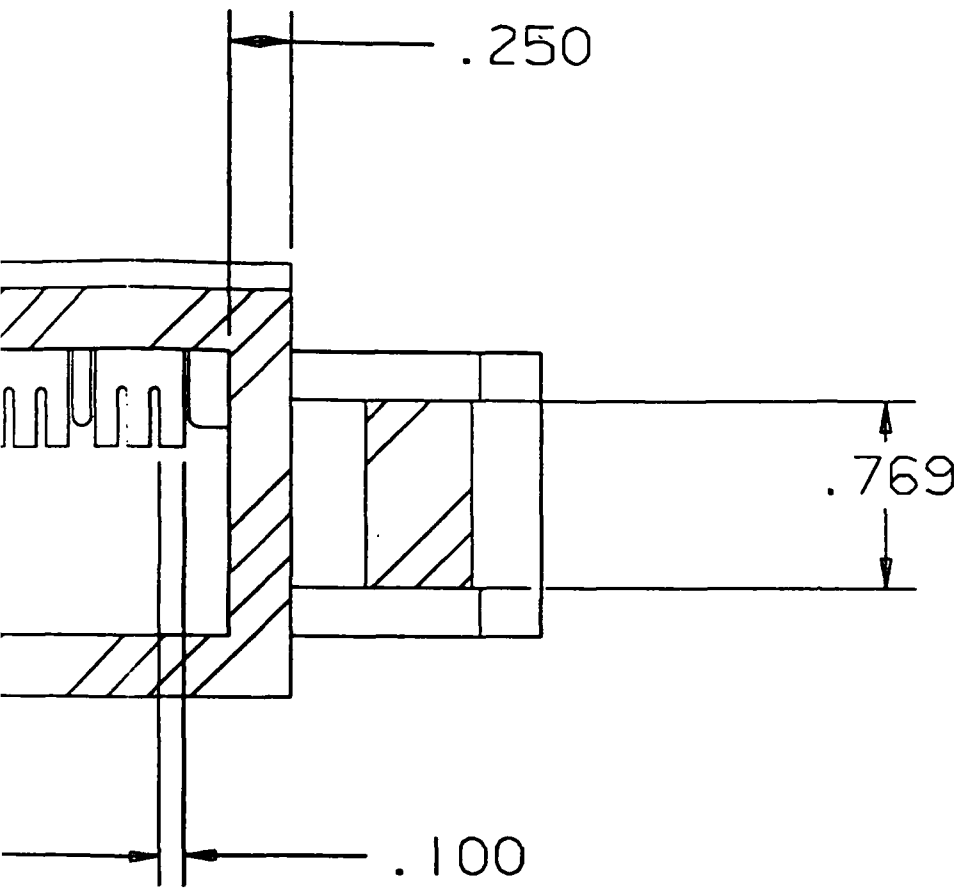

CONNECTOR LAYOUT DIMENSIONED

1

2

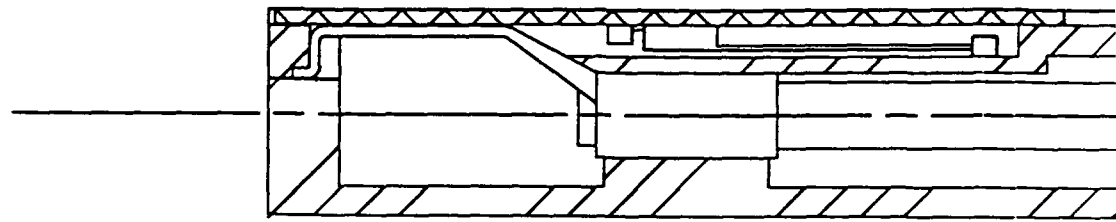

120/240V 60AMP 3PHASE MALE (

SIDE

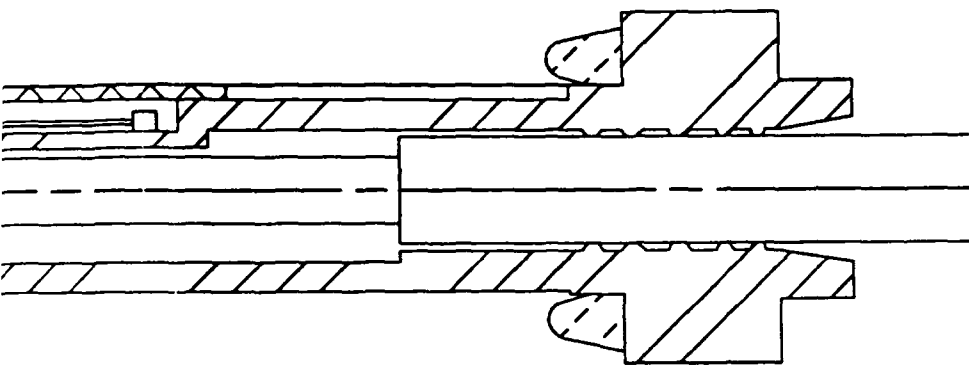

MALE CONNECTOR LAYOUT

1

2

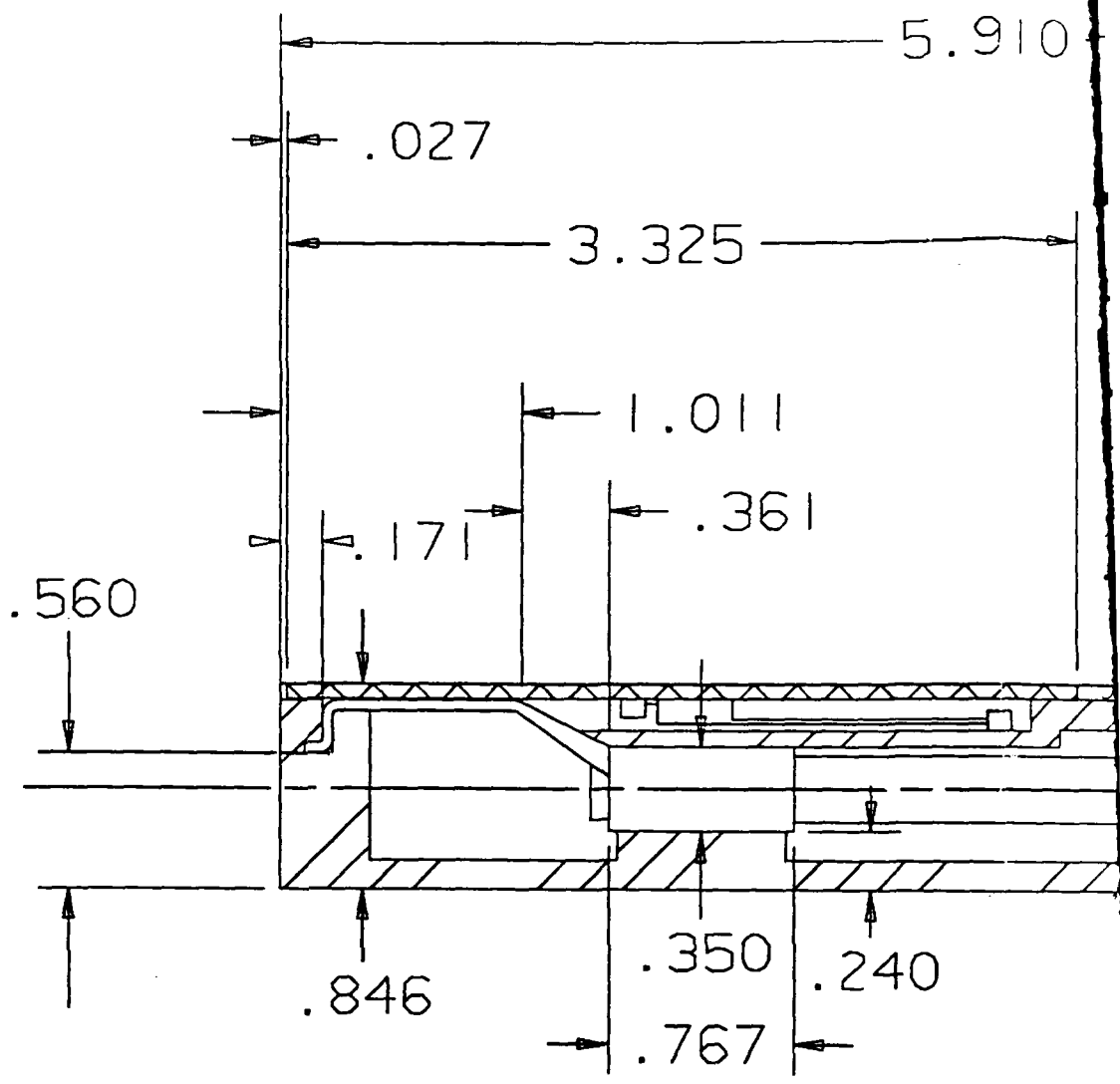

120/240V 60AMP 3PHASE MALE CONNECTOR

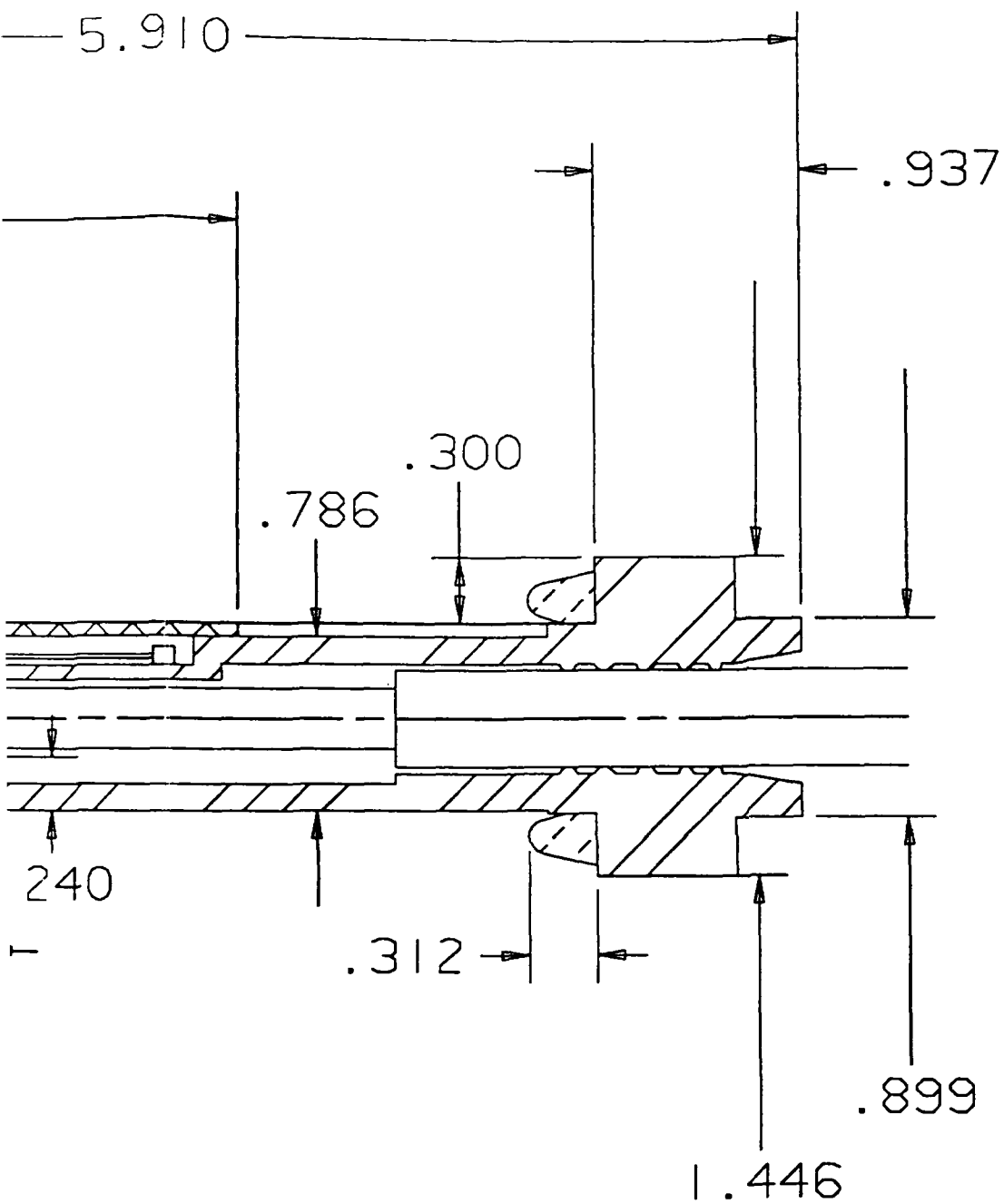

CONNECTOR LAYOUT DIMENSIONED

2

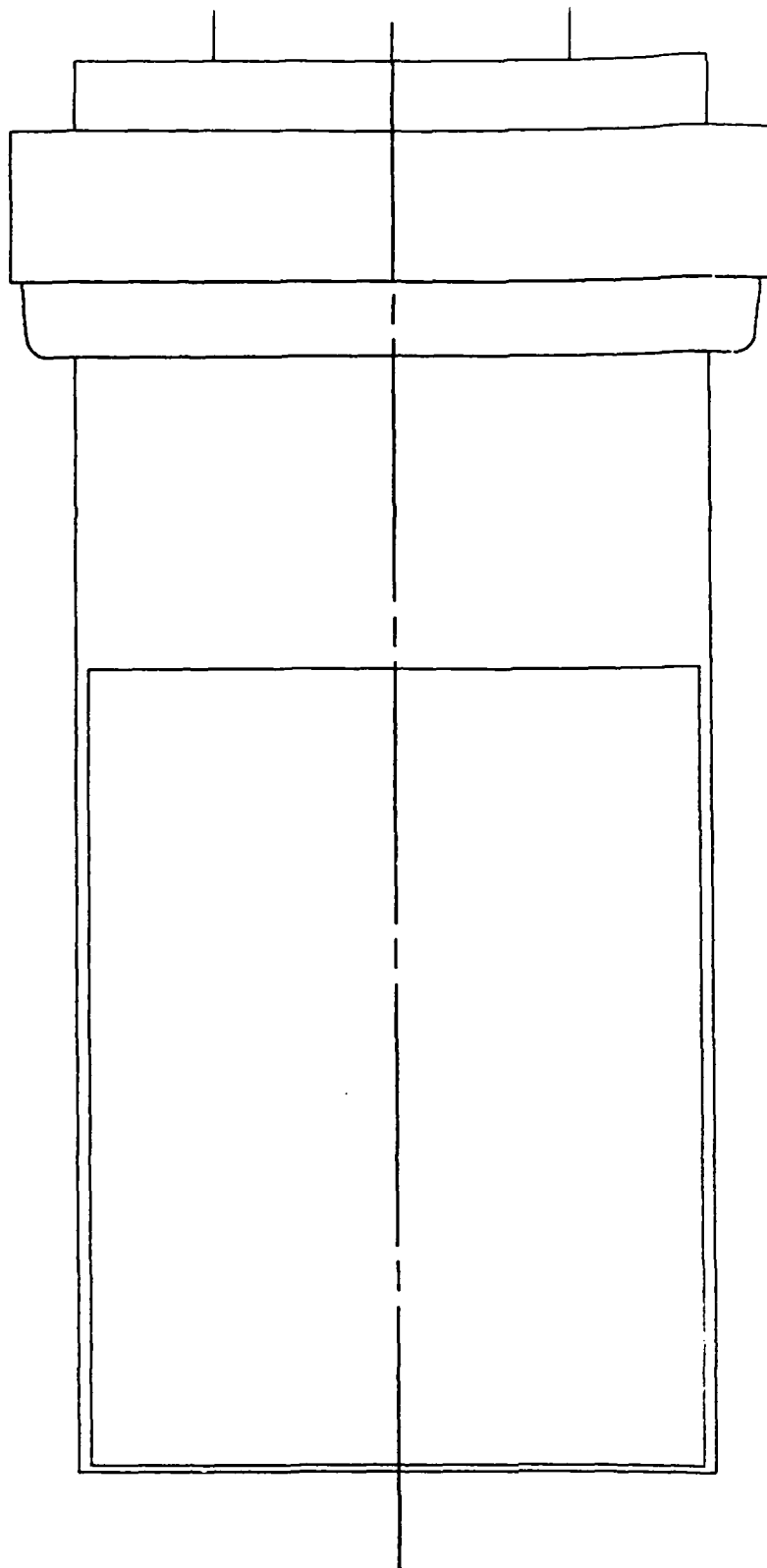

120/240V 60 AMP 3PHASE MALE CONNECTOR

TDP

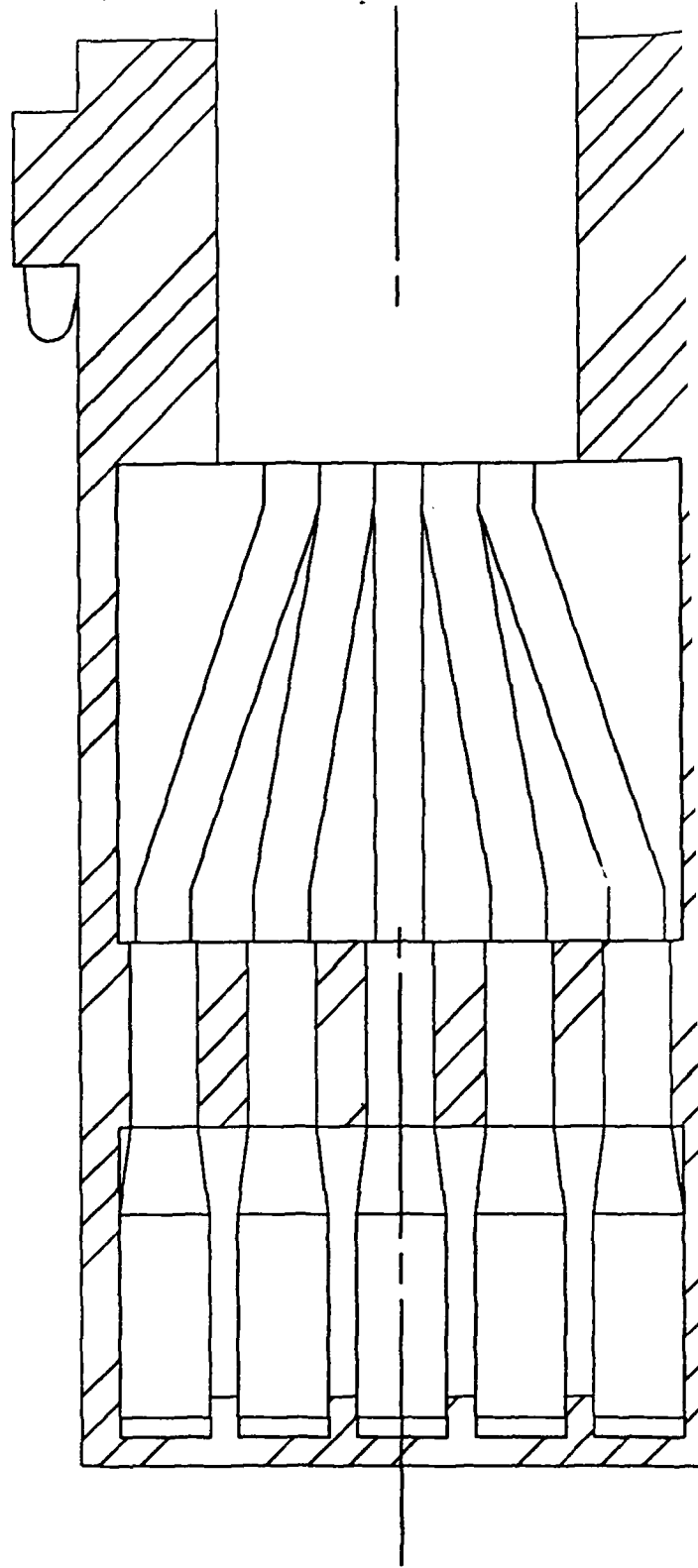

120/240V 60 AMP 3PHASE MALE CON

TOP

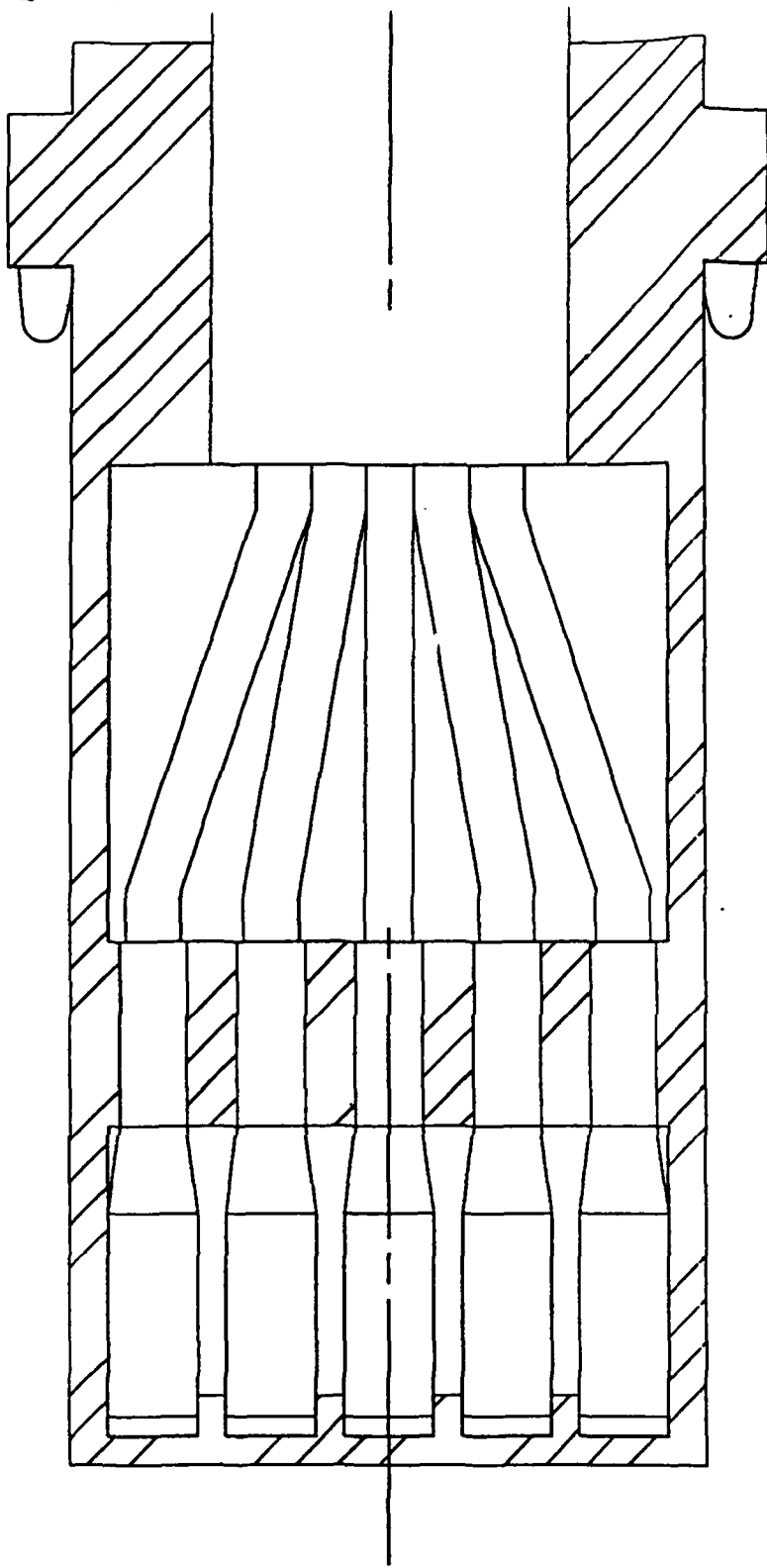

30 AMP 3PHASE MALE CONNECTOR LAYOUT

1

2

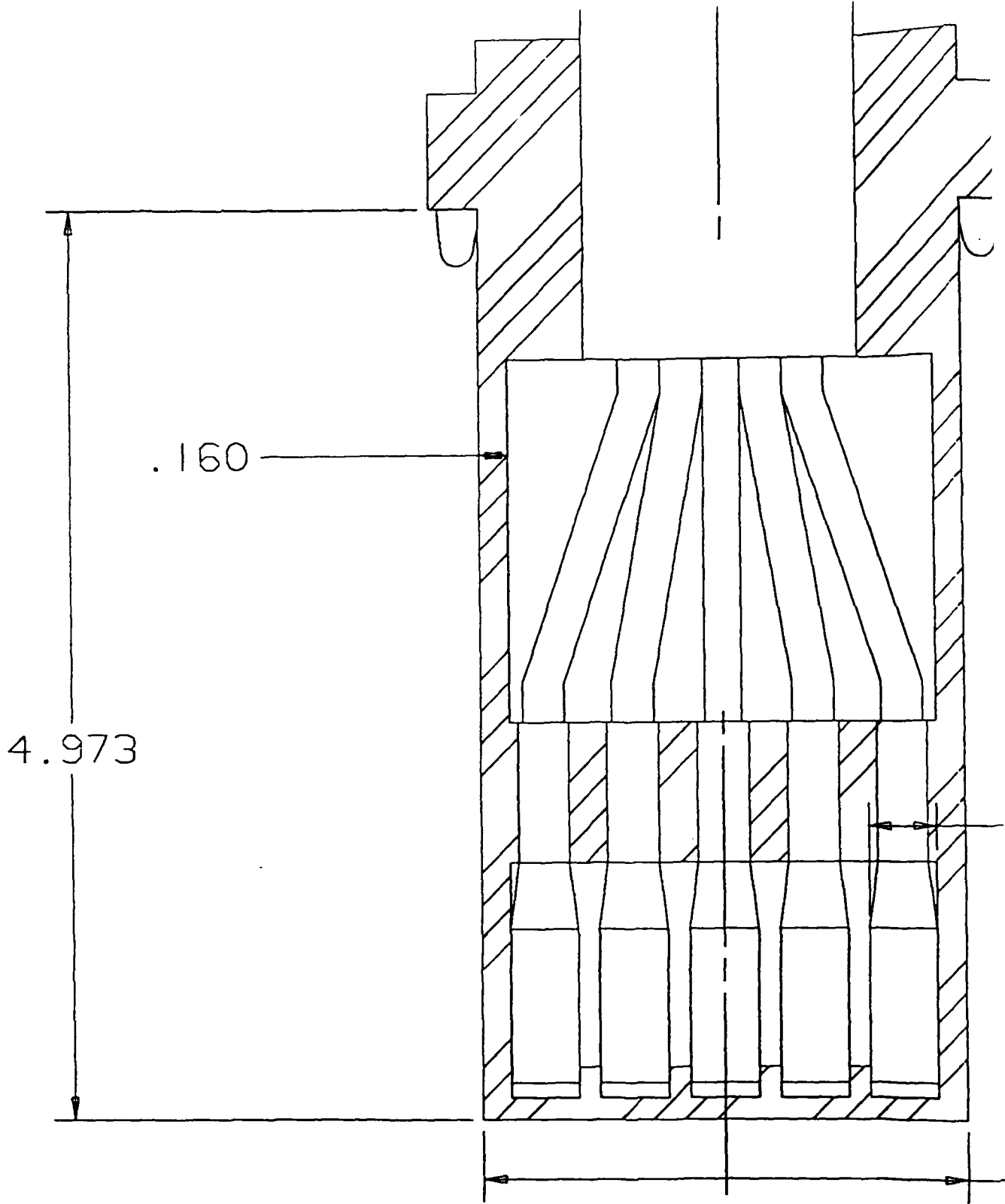

120/240V 60 AMP 3PHASE MALE CONNECTOR

TOP

SIDE

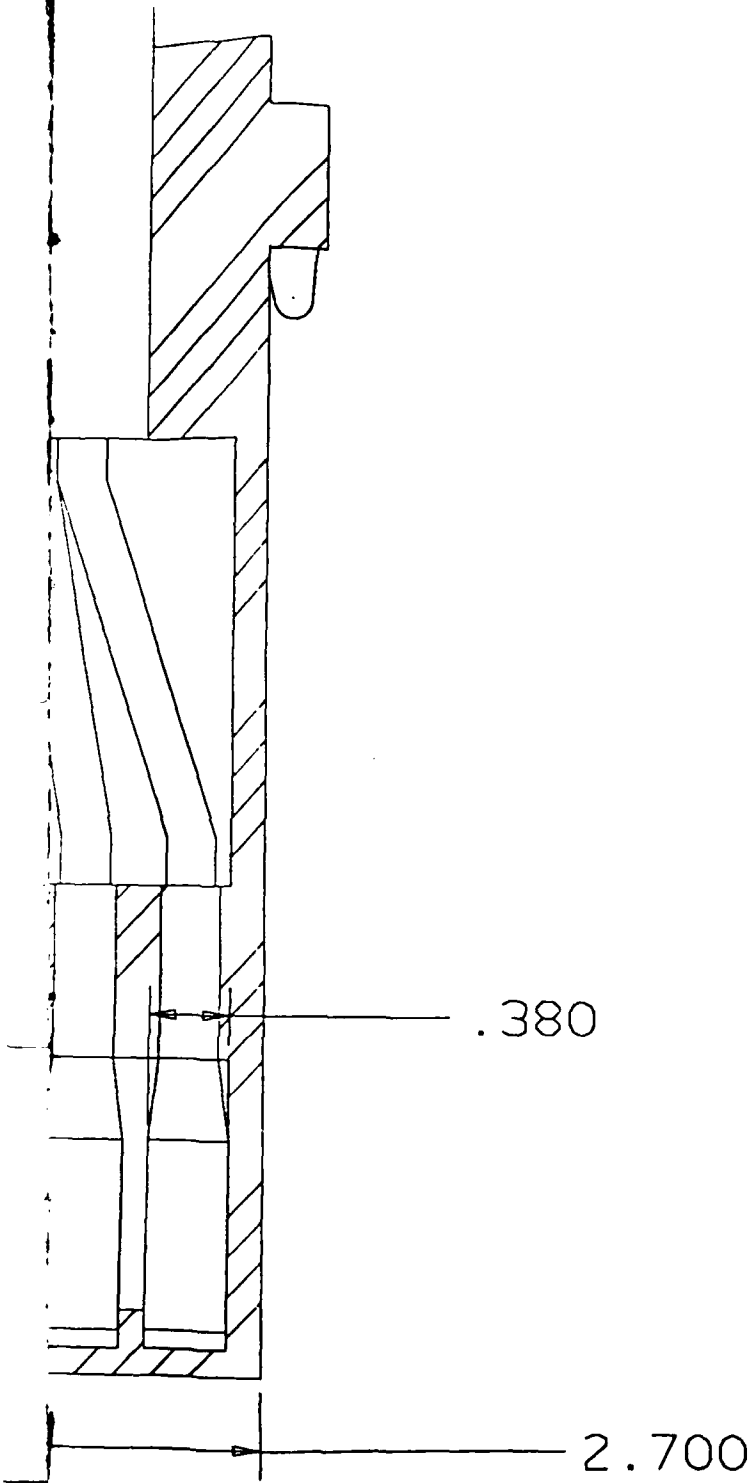

CONNECTOR LAYOUT DIMENSIONED

2

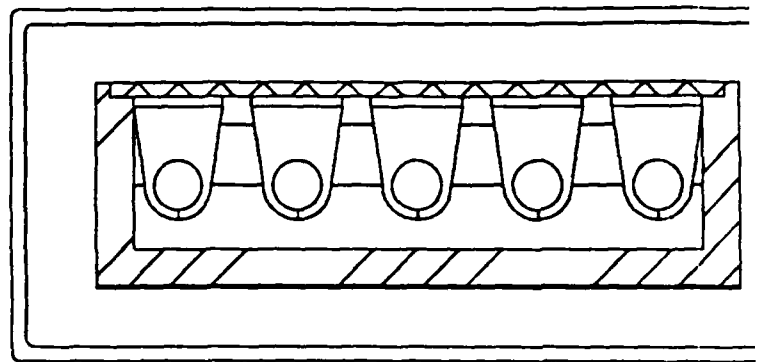

120/240V 60AMP 3PHASE MALE C

FRONT

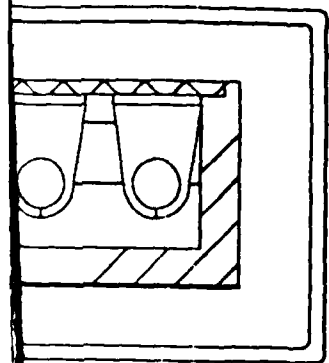

MALE CONNECTOR LAYOUT

1

2

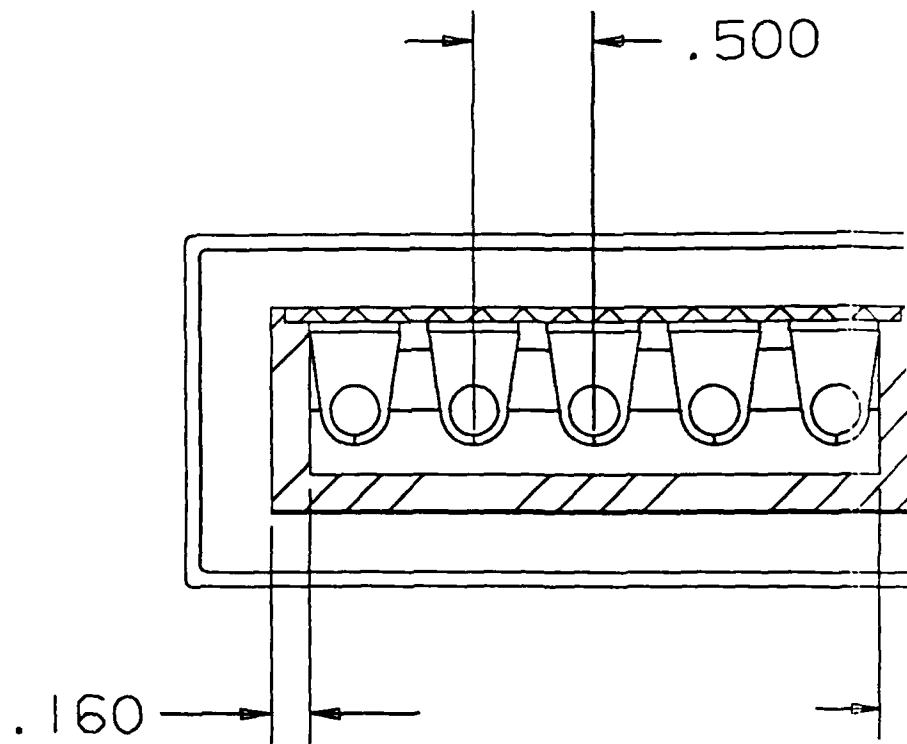

120/240V 60AMP 3PHASE MALE CONNECTOR

FRONT

.500

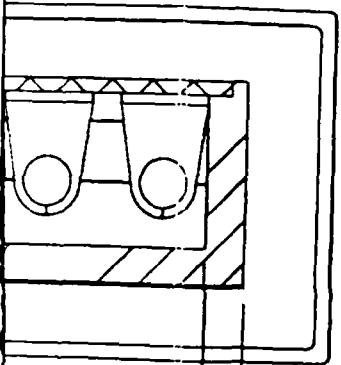

.160

CONNECTOR LAYOUT DIMENSIONED

1

2

## CONCLUSION

A concept for an improved electrical distribution system to meet Army mobility needs has been developed. The concept features improved durability with cable and mated connectors designed to withstand being driven over without damage, greatly reduced weight, faster deployment due to equipment mounted reels, and snap on connectors, and improved environmental resistance/MTBF thru the use of spring loaded protective dust covers, ultrasonic assembly, and corrosion proof high impact advanced polymer housing.

LMED  
-88