

AD-A182 510

AUTOMATIC ROBOT INITIALIZATION USING A PLANAR TARGET
SCANNED BY AN OPTICAL (U) CARNEGIE-MELLON UNIV
PITTSBURGH PA ROBOTICS INST R Q YANG ET AL APR 87
CMU-RI-TR-87-9

1/1

UNCLASSIFIED

FIG 12/9

NL

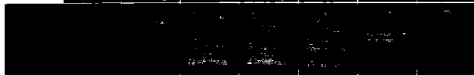

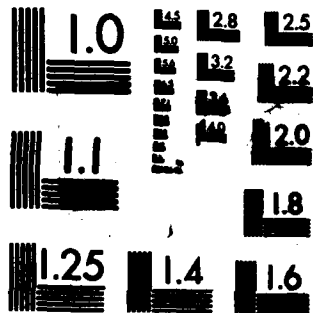

MICROCOPY RESOLUTION TEST CHART
NATIONAL BUREAU OF STANDARDS-1963-A

DTIC FILE COPY.

12

AD-A182 510

**Automatic Robot Initialization
Using a Planar Target Scanned by an
Optical Reflection Sensor**

R. Q. Yang* and M. W. Siegel

CMU-RI-TR-87-9

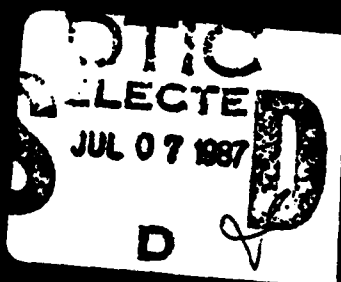

Carnegie-Mellon University

The Robotics Institute

Technical Report

Approved for public release
Distribution Unlimited

87 7 1 063

②

**Automatic Robot Initialization
Using a Planar Target Scanned by an
Optical Reflection Sensor**

R. Q. Yang* and M. W. Stegal

CMU-RI-TR-87-9

The Robotics Institute
Carnegie Mellon University
Pittsburgh, Pennsylvania 15213

April 1987

DTIC
ELECTE
JUL 07 1987
S D
D

Copyright © 1987 Carnegie Mellon University

*Permanent address: Shenyang Institute of Automation, Chinese Academy of Sciences, Shenyang, China

DISTRIBUTION STATEMENT A
Approved for public release
Distribution Unlimited

87 7 1 063

Unclassified

SECURITY CLASSIFICATION OF THIS PAGE (When Data Entered)

REPORT DOCUMENTATION PAGE		READ INSTRUCTIONS BEFORE COMPLETING FORM	
1. REPORT NUMBER CMU-RI-TR-87-9		2. GOVT ACCESSION NO. A182 510	
3. TITLE (and Subtitle) Automatic Robot Initialization Using a Planar Target Scanned by an Optical Reflection Sensor		4. RECIPIENT'S CATALOG NUMBER	
5. AUTHOR(s) R. Q. Yang and M. W. Siegel		6. TYPE OF REPORT & PERIOD COVERED Interim	
7. PERFORMING ORGANIZATION NAME AND ADDRESS Carnegie-Mellon University The Robotics Institute Pittsburgh, PA 15213		8. PERFORMING ORG. REPORT NUMBER	
9. CONTROLLING OFFICE NAME AND ADDRESS		9. CONTRACT OR GRANT NUMBER(s)	
10. MONITORING AGENCY NAME & ADDRESS (if different from Controlling Office)		10. PROGRAM ELEMENT, PROJECT, TASK AREA & WORK UNIT NUMBERS	
11. DISTRIBUTION STATEMENT (of this Report) Approved for public release; distribution unlimited		11. REPORT DATE April 1987	
12. DISTRIBUTION STATEMENT (of the abstract entered in Block 20, if different from Report) Approved for public release; distribution unlimited		12. NUMBER OF PAGES 15	
13. SUPPLEMENTARY NOTES		13. SECURITY CLASS. (of this report) Unclassified	
14. KEY WORDS (Continue on reverse side if necessary and identify by block number)		14. SECURITY CLASSIFICATION/CONTROLLING SCHEDULE	
15. ABSTRACT (Continue on reverse side if necessary and identify by block number) We describe an automatic initialization scheme for finding a point of coincidence between a robot's internal coordinate system and the coordinate system of its work space. Our method uses an optical transmitter-receiver pair mounted on the robot end effector to scan a T-shaped planar target mounted on the work surface. An automated iterative method for moving a point on the end effector into precise coincidence with the point of intersection between a sensed plane parallel to the work surface and a sensed line normal to the work surface is shown to converge rapidly.			

DD FORM 1 JAN 73 1473

EDITION OF 1 NOV 65 IS OBSOLETE
GPO 688-644-6001

Unclassified

SECURITY CLASSIFICATION OF THIS PAGE (When Data Entered)

Table of Contents

1 Abstract	1
2 Introduction	2
3 Configuration	3
3.1 Target	3
3.2 Sensor	4
3.3 Initialization Procedures	4
3.3.1 Waist Joint Initialization	4
3.3.2 Shoulder and Elbow Joint Initialization	5
4 Initialization Accuracy Analysis	7
4.1 Accuracy as a Function of Initialization Cycles	8
4.2 Relationship Between Accuracy of Initialization and Original Elbow Angle	10
4.3 Relationship Between Accuracy of the Initialization and Parameters B, K, and D	10
4.4 Considerations About Elbow Orientation	10
4.5 Considerations About the Wrist Joint	11
5 Design	12
6 Limitation	13
7 Conclusion	13

Accession For	
NTIS CRA&I	<input checked="" type="checkbox"/>
DTIC TAB	<input type="checkbox"/>
Unannounced	<input type="checkbox"/>
Justification	
By <i>lth on file</i>	
Distribution/	
Availability Codes	
Dist	Avail and/or Special
<i>A-1</i>	



List of Figures

Figure 1: T-shaped target	3
Figure 2: Transmitter-receiver pair and detection circuit	4
Figure 3: Steps 1 (shoulder-forward) and 2 (elbow-forward)	5
Figure 4: Step 3 (shoulder and elbow back-rotation)	6
Figure 5: Error caused by inexact placement of the target	8
Figure 6: $Y_{W_1}^{(3)}(B_1)$	9
Figure 7: ERROR(B_1)	10
Figure 8: ERROR(B_2)	11
Figure 9: ERROR(K)	11
Figure 10: ERROR(D)	12
Figure 11: Robot arm with wrist	13
Figure 12: Tolerance on angle B_1	14

1 Abstract

We describe an automatic initialization scheme for finding a point of coincidence between a robot's internal coordinate system and the coordinate system of its work space. Our method uses an optical transmitter-receiver pair mounted on the robot end effector to scan a T-shaped planar target mounted on the work surface. An automated iterative method for moving a point on the end effector into precise coincidence with the point of intersection between a sensed plane parallel to the work surface and a sensed line normal to the work surface is shown to converge rapidly.



2 Introduction

Even simple robots are generally able to execute differential motions with reasonable accuracy, and high quality robots come equipped with absolute encoders that enable them to discern their pose. But even high quality robots are generally oblivious to how their internal coordinate system maps onto the coordinate system of their work space. In short, even the best robots, which run closed loop kinematically, generally run open loop with respect to the coordinate systems of their working environments.

But provided that the distance and angle measuring systems of both the robot and the work space are themselves adequate, finding a single point of coincidence between the two coordinate systems is sufficient to establish the mapping between them.¹ For example, the instruction manual for the MICROBOT TeachMover [2] robot on which we implemented a demonstration of our procedure suggests an operator run initialization procedure in which the robot arm is located on a one-square-per-inch cartesian grid, and the end effector is moved (using the teach pendant) into a specified pose above a point in this space. The method is simple, but it is tedious, inaccurate, and prone to operator errors and inconsistencies.

This paper describes a simple and precise sensor based automatic initialization method using a planar target scanned by an optical reflection sensor. We developed a demonstration of this system specifically for an articulated arm robot with waist, shoulder, and elbow degrees of freedom, but our method is generally applicable to any robot with similarly implemented degrees of freedom, and the principles are easily adapted to robots with other degrees of freedom and correspondingly different internal coordinate systems.

Dealing automatically with degrees of freedom beyond the three consisting of waist, shoulder, and elbow will require additional sensor capabilities, but the limited system described here can still be retained as a subset. Since the robot we used for the demonstration also has wrist angle, wrist rotation, and gripper closure degrees of freedom, we have to specify how we will remove the degeneracy associated with these degrees of freedom. The method may be manual or sensor based and automatic. In our demonstration, we resolve the degeneracy by a manual pre-initialization wherein we adjust the plane of the gripper action to be tangent to a cylinder concentric with the waist rotation axis, we close the gripper fingers to a standard gap, and we use the coordinating features of the robot controller firmware to preserve these conditions throughout waist, shoulder, and elbow motions.

Our system has two hardware components:

1. a planar target painted on or attached to the work surface; and
2. an optical transmitter-receiver pair operated as a proximity sensor.

Our method requires that the sensor be able to:

1. guide the end effector reproducibly to some specified height above the work surface, irrespective of where on the work surface;

¹We refer to the process of finding one such point as "initialization," distinguishing it from the more complex (and less frequently required) process of "calibration," the verification and correction of the adequacy of the two measuring systems.

2. guide the end effector reproducibly to positions directly above transitions between target and work surface;
3. accomplish the latter robustly over at least a small range of heights.

In our implementation the sensor is an optical proximity sensor, the work surface is white, and the target is black. However there is no obstacle to implementing this system with other targets and target detection schemes, not necessarily optical.

3 Configuration

3.1 Target

The target, affixed to the work surface, is a T-shaped pattern with a body that is part of a sector of a circle centered on the waist rotation axis, and with a rectangular head, as shown in Figure 1. In the first part of the initialization procedure, the sensor directs initialization of the waist joint by finding the radial line A in Figure 1. In the second part of the procedure, the sensor directs initialization of the shoulder and elbow joints by iteratively adjusting them while repetitively finding the tangent line B in Figure 1. It is most convenient to perform the shoulder and elbow initialization at a fixed waist joint angular offset from the waist joint initialization position.

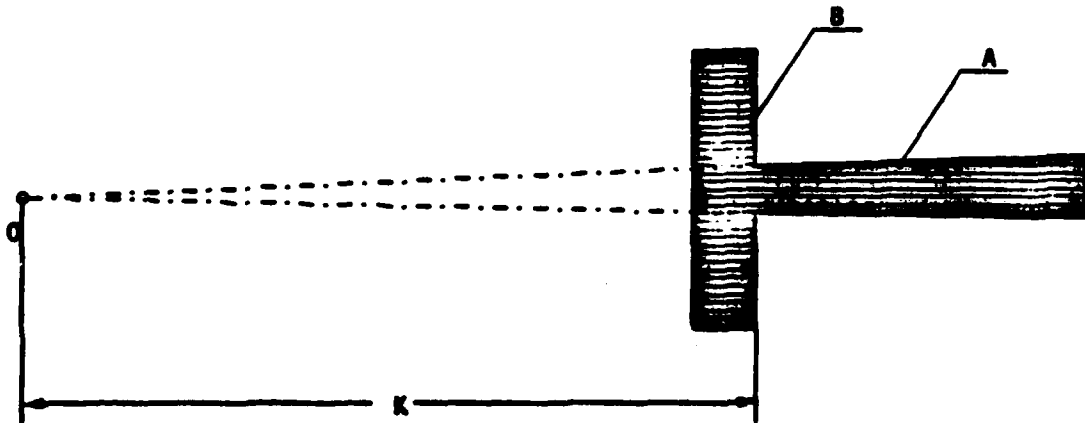

Figure 1: T-shaped target

3.2 Sensor

In our demonstration system the sensor is a commercial optical proximity sensor [1] consisting of an LED integrally packaged with a photodetector, and with simple lenses whose optical axes intersect about a centimeter from the package. When the outgoing infra-red light beam meets a more-or-less white material at about a centimeter, sufficient radiation from the LED is reflected back to the phototransistor to fire the schmidt trigger output circuit (see Figure 2). Since the precise triggering distance from the target is sensitive to the target reflectivity, to obtain high reproducibility it is necessary to standardize the background reflectivity immediately adjacent to the target. This is easily accomplished by integrating a small patch of standard background with the target, e.g. by painting the target on a rectangle of adhesive paper of reproducible reflectivity.

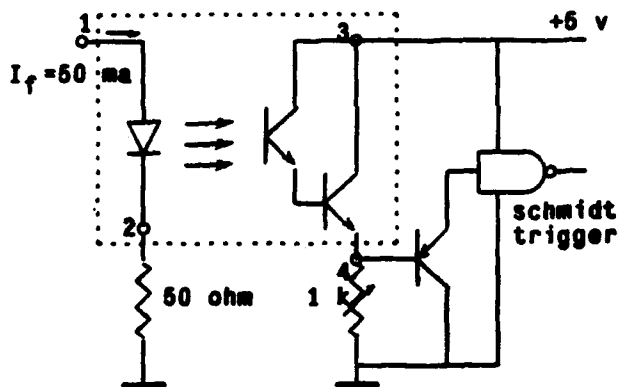

Figure 2: Transmitter-receiver pair and detection circuit

3.3 Initialization Procedure

The robot is powered up, and moved by means of the teach pendant to any position near the intersection of lines A and B in Figure 1, in the one work surface quadrant they define, and between one and five centimeters above the work surface. A suitable starting point could, of course, be found automatically by exhaustive blind search, but there would be little or no practical value in doing so.

Automated procedures for initializing the robot waist, shoulder, and elbow joints are then called. The sequence of events is outlined in the following sections.

3.3.1 Waist Joint Initialization

Simple, narrow search algorithms effect the following motions:

1. The shoulder is rotated toward the work surface until the proximity sensor fires, at approximately one centimeter above the surface;
2. Shoulder rotations are stopped, and the waist joint is rotated until the radial line A is found (Figure 1).

The waist joint is thus initialized. The waist is then offset by a few degrees, putting the sensor back above the work surface in the quadrant determined by lines A and B.

3.3.2 Shoulder and Elbow Joint Initialization

This is the most difficult part: *before* initialization, it is impossible to move the end effector without also changing its height above the work surface. One approach is to oscillate about the desired height by using sensor feedback to control alternate very small shoulder and elbow motions while we search for line B. What we now show is that a sequence of much larger sequential shoulder and elbow motions will accomplish the same end much more efficiently.

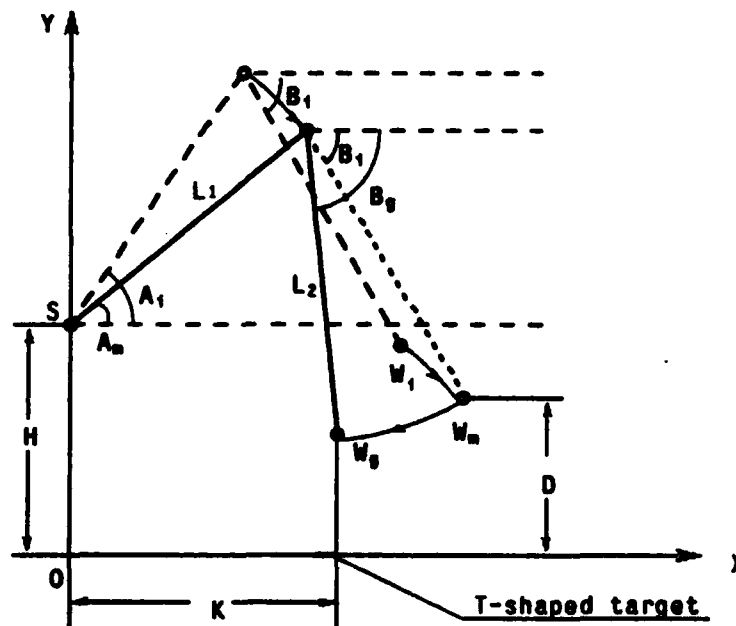

Figure 3: Steps 1 (shoulder-forward) and 2 (elbow-forward)

The sequence is:

1. The shoulder is rotated toward the work surface until the proximity sensor fires, as shown in Figure 3, path W_1 to W_m . This is a "pure shoulder rotation," *i.e.*, the robot is presumed to be equipped with well calibrated firmware to cause elbow rotation equal and opposite to the shoulder rotation, thus preserving the orientation of link L_2 in the workspace.
2. The elbow is rotated to approach line B, which is detected by the proximity sensor seeing the dark target in contrast to the bright work surface, as shown in Figure 3, path W_m to W_g . This is a "pure elbow rotation", *i.e.*, the gripper (not shown in the figure) remains in the vertical orientation it was given in the pre-initialization procedure discussed above.

3. Both the shoulder and elbow are rotated back through arbitrary small angles (A_r and B_r), as shown in Figure 4 path W_g to $W_i^{(1)}$. While the choice of A_r and B_r is arbitrary, initialization accuracy is shown in Figure 8 to depend somewhat on the value chosen for B_r . Furthermore, the algorithm assumes that once the choices are made, they are kept constant throughout the procedure.
4. The cycle (steps 1, 2, 3) is repeated several times, according to the precision required.
5. After a predetermined number of iterations, the procedure is terminated after step 2.

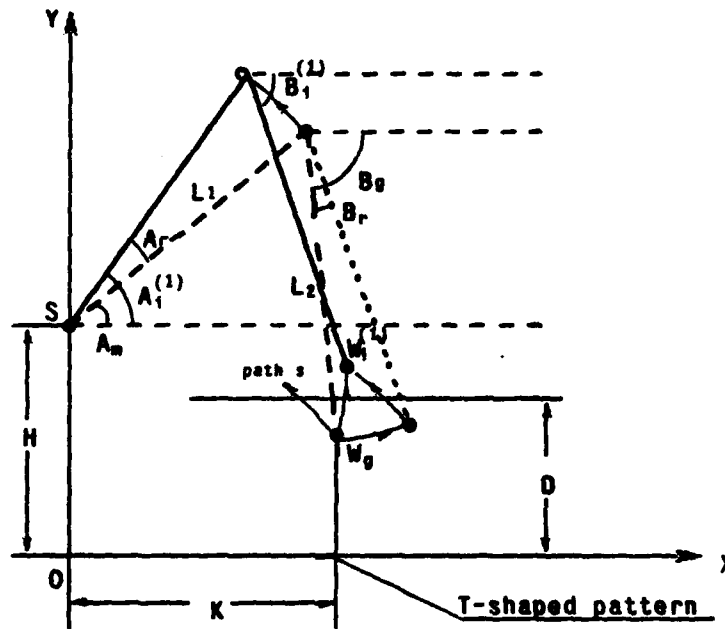

Figure 4: Step 3 (shoulder and elbow back-rotation)

It is important to notice that step 3 must be a compound motion involving back rotation of both the shoulder and elbow joints. Neither a pure shoulder motion nor a pure elbow motion could guarantee convergence of the iteration. The analysis in Section 3 derives the relationships that determine the accuracy of the initialization procedure as a function of the number of iterations and the size of the back rotations taken in step 3. The theoretical analysis, well confirmed by our experiments, shows that two or three iterations are sufficient to achieve initialization accuracy limited by the mechanics of the robot. In table 2-1 we illustrate the rapid convergence from an arbitrary pre-initialization position.

TABLE 2-1

Vertical Initialization Error vs. Procedure Cycles

($B_1=290^\circ$ $B_r=5^\circ$ $K=140$ mm $D=117$ mm)

cycles	0	1	2	3	4	5	6
error (micron)	-10138	178.2	-5.635	0.1766	-5.5×10^{-3}	1.7×10^{-4}	-5.6×10^{-6}

4 Initialization Accuracy Analysis

The accuracy analysis of the waist initialization is very simple. The only source of error² is inexact placement of the target.

Suppose that the distance between the working side of the body of the target and the axis of rotation of the base joint is e , where nominally, $e = 0$ (Figure 5). The range of hand starting positions is from R_1 to R_2 , corresponding to a waist initialization angular error range ΔC , where

$$\Delta C = C_2 - C_1 = \cos^{-1}(e/R_2) - \cos^{-1}(e/R_1)$$

which is zero if $e = 0$. For $e \ll R_1$ and $e \ll R_2$, ΔC is clearly small. For example, taking typical values $R_1 = 140$ mm and $R_2 = 180$ mm and estimating $e < 1$ mm, it follows that $\Delta C < 0.1^\circ$.

If more precise initialization of the waist joint were required, an additional procedure could be added before starting waist joint initialization:

1. the shoulder is rotated toward the work surface until the proximity sensor fires;
2. the elbow is rotated to approach the head of the target until any portion of the target head is encountered;
3. both the shoulder and elbow are rotated back through any specific small angles.

This procedure reduces the difference between R_1 and R_2 , making ΔC correspondingly very small.

The shoulder and elbow joint initialization accuracies are more difficult. They are analyzed below in terms of the number of initialization process iteration cycles.

²Recall that we are assuming the robot is kinesthetically precise, and the work space is precisely measured.

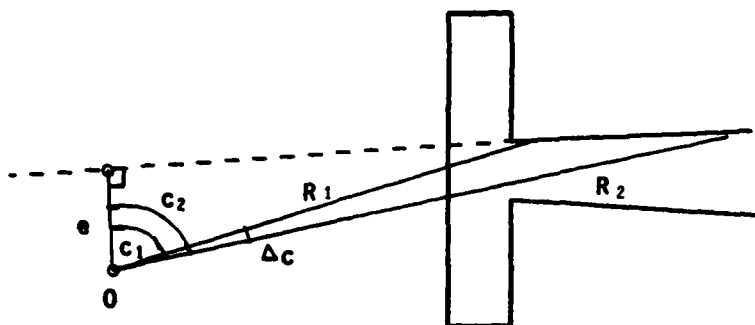

Figure 5: Error caused by inexact placement of the target

4.1 Accuracy as a Function of Initialization Cycles

In this discussion subscript *i* refers to an *initial* position, subscript *g* refers to a *goal* position, and subscript *m* refers to an intermediate position. First we suppose, with reference to Figure 3, that before initialization the shoulder of the robot is at A_i , and the elbow is at a B_i . Then after the first execution of step 1, the hand is at W_m , whose Y-coordinate is

$$Y_{W_m} = L_1 \sin(A_m) + L_2 \sin(B_i) + H = D \quad (3-1)$$

from which we determine that

$$\sin(A_m) = (D - H - L_2 \sin(B_i)) / L_1 \quad \text{and} \quad \cos(A_m) = \sqrt{L_1^2 - (D - H - L_2 \sin(B_i))^2} / L_1$$

After the first execution of step 2, the hand is at W_g , whose X- and Y-coordinates are:

$$X_{W_g} = L_1 \cos(A_m) + L_2 \cos(B_g) = K \quad \text{and} \quad (3-2)$$

$$Y_{W_g} = L_1 \sin(A_m) + L_2 \sin(B_g) \quad (3-3)$$

From Equation (3-2) we get

$$\cos(B_g) = (K - L_1 \cos(A_m)) / L_2 \quad \text{and} \quad \sin(B_g) = -\sqrt{L_2^2 - (K - L_1 \cos(A_m))^2} / L_2 \quad \text{so}$$

$$Y_{W_g} = (D - H - L_2 \sin(B_i) + \sqrt{L_2^2 - [K - \{L_1^2 - (D - H - L_2 \sin(B_i))^2\}^{0.5}]^2} + H \quad (3-4)$$

Equation 3-4 shows that Y_{W_g} depends only on B_i , not on A_i . Steps 3 and 4 iteratively reduce the dependence of Y_{W_g} on B_i . This is illustrated in Figure 6.

In step 3 of the cycle, the shoulder and elbow are rotated back through fixed arbitrary angles A_f and B_f .

The new starting position of the hand, after one cycle, is $W_i^{(1)}$, corresponding to shoulder and elbow angles

$$A_i^{(1)} = A_m + A_r \text{ and } B_i^{(1)} = B_g + B_r$$

After one additional iteration of steps 1 and 2, the new position of the hand is $W_g^{(1)}$:

$$X_{W_g}^{(1)} = L_1 \cos(A_m^{(1)}) + L_2 \cos(B_g^{(1)}) = K = X_{W_g}$$

$$Y_{W_g}^{(1)} = L_1 \sin(A_m^{(1)}) + L_2 \sin(B_g^{(1)}) + H$$

and after the n^{th} iteration, the position of the hand is $W_g^{(n)}$:

$$X_{W_g}^{(n)} = L_1 \cos(A_m^{(n)}) + L_2 \cos(B_g^{(n)}) = K = X_{W_g}$$

$$Y_{W_g}^{(n)} = L_1 \sin(A_m^{(n)}) + L_2 \sin(B_g^{(n)}) + H$$

The explicit solution quickly becomes very cumbersome, but computer simulation (Figure 6) is simple. It is interesting to note that $Y_{W_g}^{(n)}$, while constant for given robot geometry, is not equal to D .

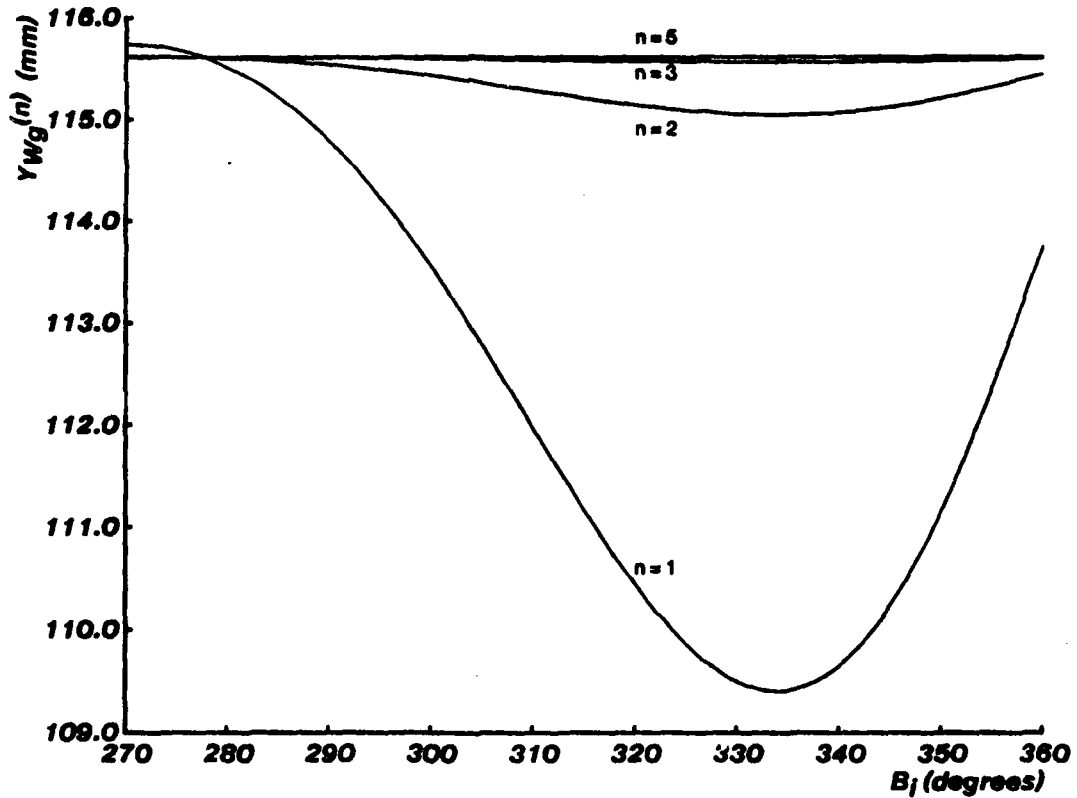

Figure 6: $Y_{W_g}^{(n)}(B_1)$

4.2 Relationship Between Accuracy of Initialization and Original Elbow Angle

Equation 3-4 shows that the accuracy of the initialization depends on the original angle (B_1) of the elbow. Figure 7 illustrates that while this dependence looks strong, the magnitude of the error is always small. This figure is the result of numerical experiments using three cycles, *i.e.*,

$$\delta = Y_{Wg}^{(3)}(B_1) - Y_{Wg}^{inf}$$

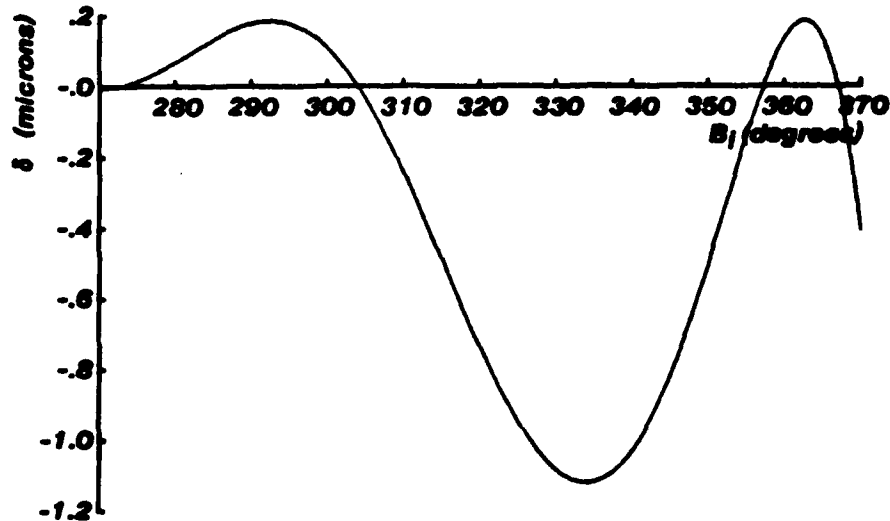

Figure 7: ERROR(B_1)

4.3 Relationship Between Accuracy of the Initialization and Parameters B_1 , K , and D

Equation 3-4 also shows that the accuracy of the initialization will change with the back rotation angle (B_1) of the elbow, or the location (K) of the T-shaped target. Figures 8, 9, and 10 illustrate, also via numerical experiments involving three iteration cycles, the errors as a function of the elbow back rotation angle (B_1), the location of the target (K), and the virtual sensor trigger height (D). These parameters can thus be determined, via numerical experiments for the geometry of any specific robot, so as to minimize the errors inherent in the method.

4.4 Considerations About Elbow Orientation

As we mentioned above, as the shoulder is rotated, the elbow nominally remains unchanged, *i.e.*, B_1 is constant. But because of mechanical or calibration imperfections, this capability is flawed:

$$Y_{Wg}^{(n)} = F(\sin(B_1 + \Delta B_1))$$

Because the value of B_1 is near 270° or -90° and ΔB_1 is very small, $\sin(B_1)$ is near $\sin(B_1 + \Delta B_1)$. For example, suppose $B_1 = 5^\circ$, $B_1 = -75^\circ$, $\Delta B_1 = 0.1^\circ$; then

$$Y_{Wg}^{(2)} \sin(B_1 + \Delta B_1) - Y_{Wg}^{(2)} \sin(B_1) = 0.6 \mu\text{m}$$

Thus the error is negligibly small.

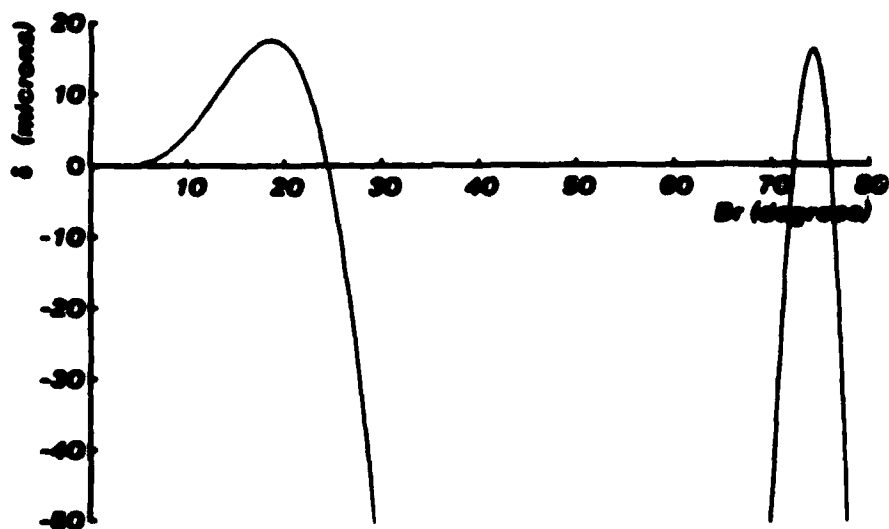

Figure 8: ERROR(B)

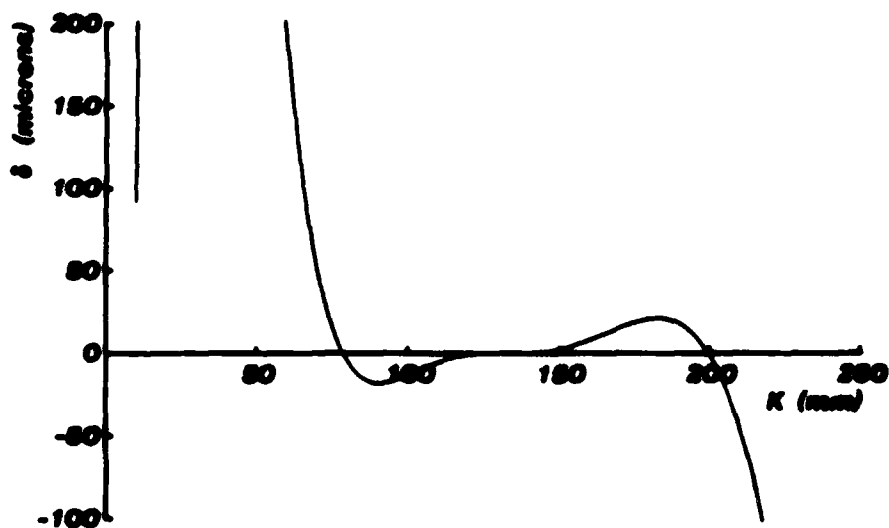

Figure 9: ERROR(K)

4.5 Considerations About the Wrist Joint

Consider that there is a wrist on the robot, as shown in Figure 11. Via the robot control firmware, shoulder or elbow rotation also causes equal and opposite wrist rotation, keeping the wrist orientation constant. As stated above, our pre-initialization sees a vertical orientation. However, as in the case of elbow orientation, the orientation of the wrist cannot be kept perfectly constant. But this only slightly affects the value of D , as shown in Figure 11. For example, if the wrist is 1° away from vertical, denoted angle Q , we obtain

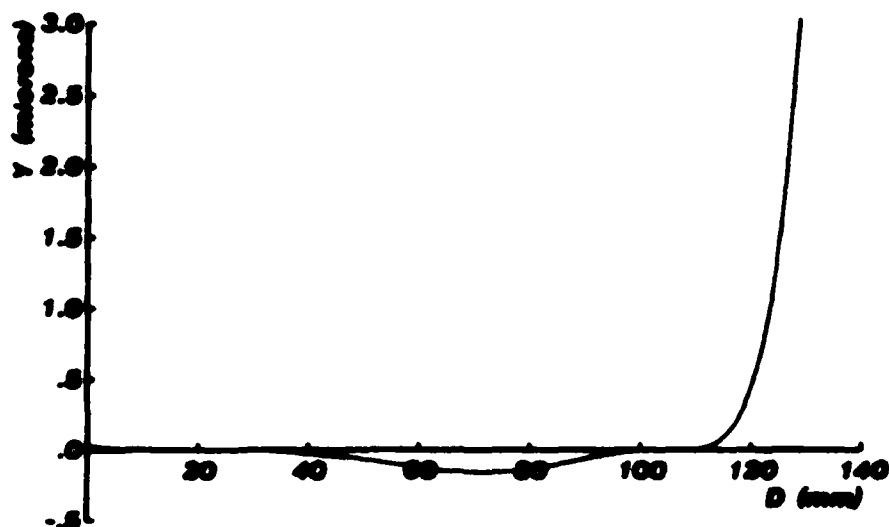

Figure 10: ERROR(D)

$$\Delta D = L_7(\cos(Q) \cdot \cos(Q + \Delta Q)) = 3 \mu\text{m}$$

$$Y_{G8} = Y_{W8} \cdot L_7$$

$$Y_{G8}^{(2)}(D) - Y_{G8}^{(2)}(D - \Delta D) = 4 \mu\text{m}$$

The method is thus insensitive to wrist pre-initialization.

5 Design

We see from the above analysis that high initialization repeatability is obtained after only a few cycles. In fact, after two cycles the accuracy of the initialization depends primarily on the quality of the robot mechanics and the resolution of the robot actuators.

Figure 8 shows that the best choice for B_1 is under 10° . Also, making the back angle B_1 small reduces the initialization time (because the distances are small). Thus we choose $B_1 = 5^\circ$.

Figure 9 shows that if the location of the T-shaped target is too close to the base of the robot or too far from it, the initialization error will increase seriously. Thus we choose $K = 140$ mm.

From Figure 11 we know $D = L_7 + h$, where h is the working distance between the proximity sensor and the work surface. For the specific sensor we used in our demonstration, h is 5 to 10 mm. Because the value of L_7 is fixed ($L_7 = 109$ in the TeachMover), the value of D is between 104 mm and 119 mm. Fortunately this is a good range for initialization with high accuracy, as shown in Figure 9. Via these considerations we choose (by electrically adjusting the trigger point, via the variable resistor in Figure 2-2) $h = 8$ mm, so $D = 117$ mm.

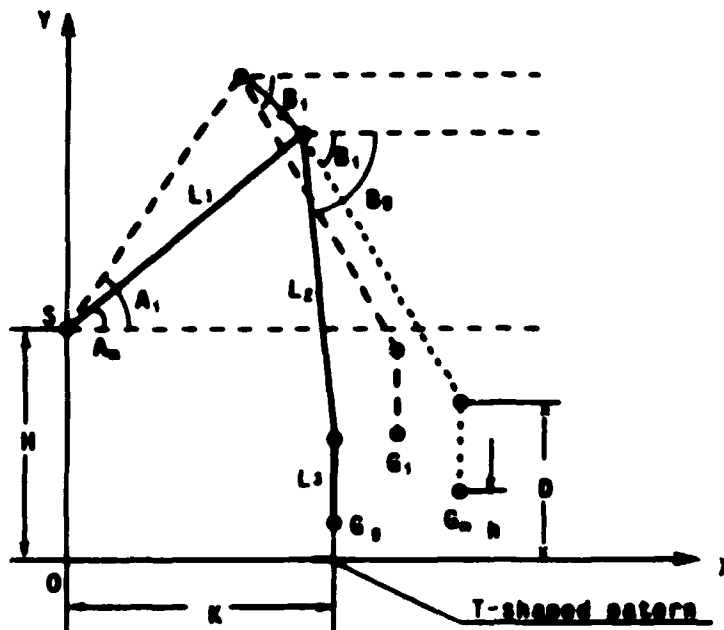

Figure 11: Robot arm with wrist

Figure 7 shows that with the set of parameters $B_1 = 5^\circ$, $K = 140$ mm, and $D = 117$ mm, an initial value of B_1 anywhere between 200° and 360° results in negligible error after three cycles.

6 Limitation

Our analysis suggests that the hand of the robot can be anywhere before the initialization, but in fact there are some practical limitations. For the method to work, the hand must be located above the T-shaped target, and the elbow-wrist link cannot be too far from vertical. The tolerance of the angle B_1 can be obtained from Figure 12:

$$B_0 = \cos^{-1}((L_2 - h)/L_2) = 17^\circ 15'$$

This tolerance is obviously so large that even "eye-ball" pre-initialization is adequate.

7 Conclusion

A simple and accurate method of automatic robot initialization has been demonstrated. The method employs only a proximity sensor and a simple T-shaped target in the work surface.

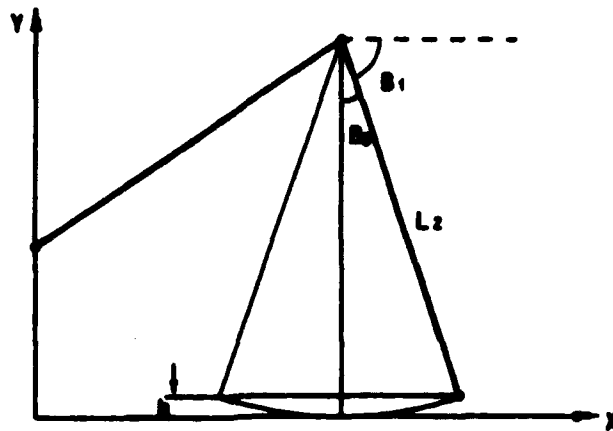

Figure 12: Tolerance on angle B_0

Theoretical analysis and numerical experiments show that the initialization error will become negligibly small after a few cycles. With an appropriate choice of parameters, after only two cycles, the initialization accuracy depends only on the quality of the robot mechanics and the resolution of its actuators.

This simple pre-initialization procedure allows for a wide range of operator inconsistency.

Experiments, not described herein but using the apparatus and parameters that we explicitly modelled, confirm the logic of the algorithm and the utility of the procedure.

References

1. F. M. Mims, III. *LED Circuits & Projects*. Howard W. Sams & Co., Inc., 1979.
2. *TeachMover User Reference Manual*. Microbot, Inc., 1982.