

AD-A103 002

FILBER OPTIC ENGINEERING SENSOR SYSTEM PHASE 1(U) NKF
ENGINEERING INC RESTON VA APR 87 NKF-87103-001/6
N00014-87-C-2032

1/1

UNCLASSIFIED

F/G 20/6

NL



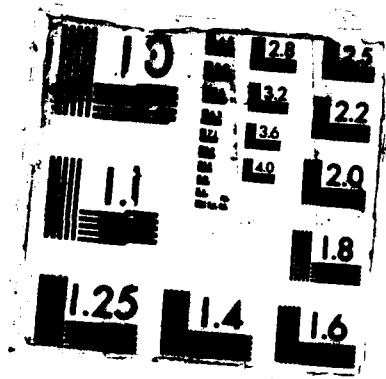

AD-A183 082

12

NKF Report No.
87103-001/6

**FIBER OPTIC
ENGINEERING SENSOR SYSTEM
FINAL TECHNICAL REPORT**

**PREPARED IN RESPONSE TO:
CONTRACT NO. N00014-87-C-2032**

**PRESENTED TO:
FIBER OPTICS TECHNOLOGY PROGRAM OFFICE
NAVAL RESEARCH LABORATORY
WASHINGTON, DC 20375-5000**

**PRESENTED BY:
NKF ENGINEERING, INC.
12200 SUNRISE VALLEY DRIVE
RESTON, VIRGINIA 22091**

**DTIC
ELECTE
JUL 24 1987**
S D
Cg D

APRIL 1987

**DISTRIBUTION STATEMENT A
Approved for public release
Distribution Unlimited**

**FIBER OPTIC
ENGINEERING SENSOR SYSTEM
FINAL TECHNICAL REPORT**

**PREPARED IN RESPONSE TO:
CONTRACT NO. N00014-87-C-2032**

**PRESENTED TO:
FIBER OPTICS TECHNOLOGY PROGRAM OFFICE
NAVAL RESEARCH LABORATORY
WASHINGTON, DC 20375-5000**

**PRESENTED BY:
NKF ENGINEERING, INC.
12200 SUNRISE VALLEY DRIVE
RESTON, VIRGINIA 22091**

APRIL 1987



Accession For	
NTIS CRA&I	<input checked="" type="checkbox"/>
DTIC TAB	<input type="checkbox"/>
Unannounced	<input type="checkbox"/>
Justification	
By <i>per ti</i>	
Distribution /	
Availability Codes	
Dist	Avail and/or Sp. dist
<i>A-1</i>	

**FIBER OPTIC
ENGINEERING SENSOR SYSTEM**

FINAL TECHNICAL REPORT

PREPARED IN RESPONSE TO:

CONTRACT NO. N00014-87-C-2032

PRESENTED TO:

**FIBER OPTICS TECHNOLOGY PROGRAM OFFICE
NAVAL RESEARCH LABORATORY
WASHINGTON, DC 20375-5000**

PRESENTED BY:

**NKF ENGINEERING, INC.
12200 SUNRISE VALLEY DRIVE
RESTON, VIRGINIA 22091**

APRIL 1987

JOHN E. DONOVAN

TABLE OF CONTENTS

<u>Section</u>	<u>Description</u>	<u>Page</u>
1.	Task Objectives.....	2
2.	Approach to the Problem.....	2
3.	Summary of Results.....	3
4.	Summary.....	15

ABSTRACT

1. The objective of this report is to summarize the results and recommendations of the NKF team activity conducted in support of NRL to develop a conceptual Fiber Optic Engineering Sensor System design.

2. A conceptual overall system, which may be derived from a number of component choices, is described. In summary, its main characteristics are:

• A two-piece sensor, comprising a transducer and a conversion module. Four choices of transducer are given, two from each of two families,

• A telemetry design combining dichroic ratiometry with "common-carrier" architecture, and

• A control/display design based on a microcomputer used as a process controller and providing built-in testing facilities.

3. The report recommends:

• That a universal transducer be developed rather than transducers specific to each sensing function,

• The construction of one transducer from each family and the testing of both to eliminate the weakest,

• The construction and testing of at least one conversion module; there would be R & D advantages in fabricating additional types of conversion modules,

• The construction and testing of hitherto untested key telemetry components, and

• The investigation and evaluation of an optimum network architecture to further increase system cost savings.

FINAL TECHNICAL REPORT

Task Title: FIBER OPTIC ENGINEERING SENSOR SYSTEM -- PHASE I

NKF Job No.: 7103-001

NRL Engineer: John E. Donovan

NKF Engineer: John T. Jenkins

1. Task Objectives:

To produce a conceptual design including preliminary specification for a network of purely passive optical sensors and a tradeoff analysis to compare the characteristics of an existing representative subsystem with future optical replacement based on the concept design. The tradeoff serves as the first quantitative step to confirm any potential improvements offered by the concept design and to identify any critical areas that might impede its realization. The Fiber Optic Engineering Sensor System (FOESS), scheduled for trial deployment aboard a naval platform by March 1989, should either eliminate or reduce limitations of present wire systems. These limitations include:

- Shortcomings in Ability, Availability and Survivability.
- Susceptibility to Electro-Magnetic Interference (EMI).
- Penalties due to Weight and Volume.
- High Installation and Supportability Costs.
- Limited Standardization.

In addition FOESS offers the Navy an opportunity to increase the application of fiberoptic technology and foster the greater use of sensor systems.

2. Approach to the Problem:

The NKF/ART Team used an "Application Driven" approach to satisfy the program objectives. A "top down" design was developed to ensure that the finished product meets the Navy end-user needs. This contrasts with a "Widget Driven" approach where program objectives are tailored so that a particular device can be used. Although the application approach requires increased effort to understand the true needs of the functional system, it yields greater confidence in the answer obtained.

Application of this approach has yielded the following conclusions:

- Existing Technology and Off-the-Shelf Components must be used wherever practicable to reduce development time, cost and risk, so that a trial shipboard system can be installed by March 1989.
- Redundant Components and Telemetry are necessary to ensure reliable and survivable operation despite breakdowns or combat damage.
- Components Must be Fully Specified and Ruggedized so that systems can be easily fabricated and readily installed, will survive the harsh at-sea environment, and to promote compatibility with future applications, fiberoptic sensors and other components.
- "Common Carrier" Telemetry with Standard Interfaces and Components will provide operational flexibility and reduce installation and reconfiguration costs.
- Optical Dichroic Ratiometry (ODR) provides a simple way to mitigate telemetry artifacts (e.g., varying link losses). ODR will also provide an "Optical Ground" to permit traditional voltmeter style maintenance and troubleshooting techniques.
- Multiple Test Ports, Built-In Test Equipment and "Self Test" Function will provide enhanced maintenance and troubleshooting capabilities using existing skills, techniques and equipment.
- LED/PIN Opto-electronic Technology will be used because it is simple, safe, reliable and cost effective.
- A Single Universal Transducer Coupled to Specialized Conversion Modules senses a large variety of parameters with less development time/cost, minimizes inventory investment and maximizes standardization.
- Multimode/Intensity Modulating (IM) Transducers are adequate and based on a mature, low cost technology - one easily understood and maintained by personnel with a ninth grade education and who may have little or no knowledge about optics or fiberoptics.

3. Summary of Results:

Results of the work completed comprise a concept design with preliminary specifications for a FOESS and tradeoff analysis conclusions. For further details regarding the results presented in this report please refer to the FOESS Concept Design Review Data Package.

Concept Design:

The overall system concept design is briefly described in the subsections below followed by a discussion of the salient design details.

Overall System Description:

The principal features of the system design include multiple control stations, redundant signal paths, multiple access ports and fiberoptic sensors. The sensors are modular and composed of two parts: a standard transducer coupled to specialized conversion modules.

As Figure 3-1 illustrates, the concept design consists of three major elements:

- **Control/Display:** This subsystem, based on a microcomputer using standard off-the-shelf process control software, is designed to emulate existing control, display and alarm functions, govern the sensor network and interface with future Interior Communication (I.C.) systems. The microcomputer will also be used as Built-In Test Equipment (BITE) to speed troubleshooting and detect problems before they become failures.
- **Telemetry:** The telemetry subsystem design, based on 100 um, multi-mode, graded index fiber, includes PIN receivers, redundant sets of emitters of different wavelengths to implement Optical Dichroic Ratiometry (ODR), cabling hardware (junction boxes, patch panels) and all fiberoptic components used to couple light to and from the sensors. These components include: fiber splices, connectors, star couplers and sensor couplers.
- **Sensors:** The sensor design consists of a standardized reflective Intensity Modulating (IM) multimode displacement fiberoptic transducer coupled to specialized mechanical conversion modules. This approach facilitates many different sensing functions while presenting a standard input to the network and having minimum ILS impact. Two families of candidate universal transducers were conceived. The first family, consisting of the Hydraulically Actuated Moving Lens (HAML) and the Gas Attenuating Constant Volume/Pressure (GACVP) transducers are optimized for high performance and moderate cost. The second family consisting of the Fiber-Lens Connector Switch (FLCOS) and Focused Connector Moving Diaphragm (FOCMD) transducers are optimized for minimum cost/high volume production and adequate performance.

Design Details:

Sensors:

The search for and analysis of existing off-the-shelf continuous fiberoptic sensors failed to identify a candidate that was clearly compatible with our requirements for a universal transducer.

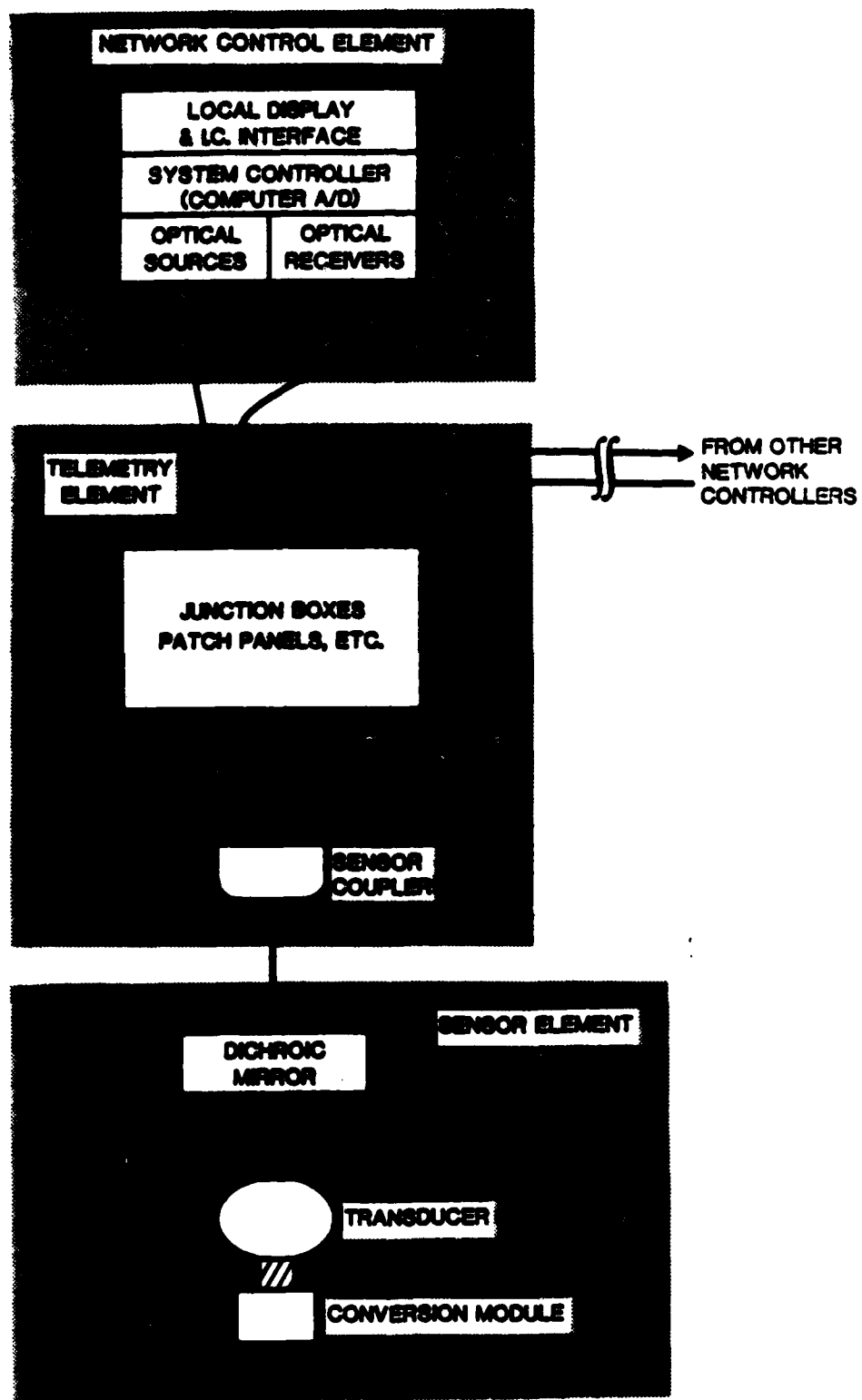

Figure 3-1. Concept Design Basic Block Diagram

The "Application Driven" approach used to produce the concept design is given by evident in the requirements derived for universal transducers. As listed in Table 3-1, "System" requirements are based on end-user needs for a reliable system with adequate resolution free of environmental artifacts. The "Telemetry" requirements are directed towards producing a "transparent" telemetry system that is robust, reliable and survivable. Provision for Optical Dichroic Ratiometry is a "System/Telemetry" requirement because it facilitates "transparent" telemetry operation and simplifies system maintenance.

An example of the factors leading to the preceding transducer requirements is the analysis of misalignment losses inherent in "simple" reflective transducers. As Figure 3-2 illustrates, a simple reflective transducer is highly sensitive to construction and vibration misalignments, requiring that a portion of their range be used to compensate for these factors.

A misalignment and vibration insensitive sensor configuration was developed to reduce these losses. Illustrated in Figure 3-3, the design relies on the symmetry of a lens placed "2f" from both the input fiber and fixed plane mirror to cancel these losses. Figure 3-4 clearly shows the improvement possible with this design. The Hydraulically Actuated Moving Lens (HAML) transducer, illustrated in Figure 3-5, is a possible realization of this approach.

Telemetry:

FOESS's application pointed out the need to provide a robust telemetry design that:

- Is insensitive to environmental, installation and operational link loss variations;
- Utilizes fiber with sufficient throughput to illuminate passive reflective sensors yet with sufficient bandwidth to serve as a medium for communications grade signals;
- Provides multiple and redundant source and signal paths;
- Permits convenient "Pre-Fibered" and reconfiguration of a platform.
- Is easily maintained and repaired.

Answering these requirements is a telemetry design combining dichroic ratiometry with a "Common Carrier" architecture, standard 100 um graded index network fiber, sensor couplers, 200 um step index transducer fiber, modular dichroic source units and low cost photo-receiver processors.

Optical Dichroic Ratiometry (ODR) is a key element in the design. Sensitivity to link losses and absolute optical power level are automatically eliminated by using the amplitude of the reference wavelength to scale the data signal. ODR also greatly simplifies maintenance and troubleshooting by providing an "Optical Ground."

Table 3-1. Universal Transducer Requirements

System Driven

- o 1% Resolution.

- o Protected optical path within the sensor to prevent degradation from misalignment and environmental effects, e.g. dirt, dust, grease, etc.

- o Vibration/misalignment insensitive design.

System/Telemetry Driven

- o Provisions for Optical Dichroic Ratiometry (ODR).

Telemetry Driven

- o Avoid mode modulating or mode sensitive transducers, e.g., micro-benders, fluid immersion and "simple" reflective sensors. Instead, utilize transducers with focusing optics.

- o Reflective transducers to facilitate redundant signal paths and to optimize ODR operation.

- o 200 um compatibility to optimize throughput and permit the use of the low cost Fused Bundle Sensor Coupler Connector (FBSCC), that interfaces the sensor with six 100 um network fibers.

- o Excess Insertion Loss (EIL) < 8 db.

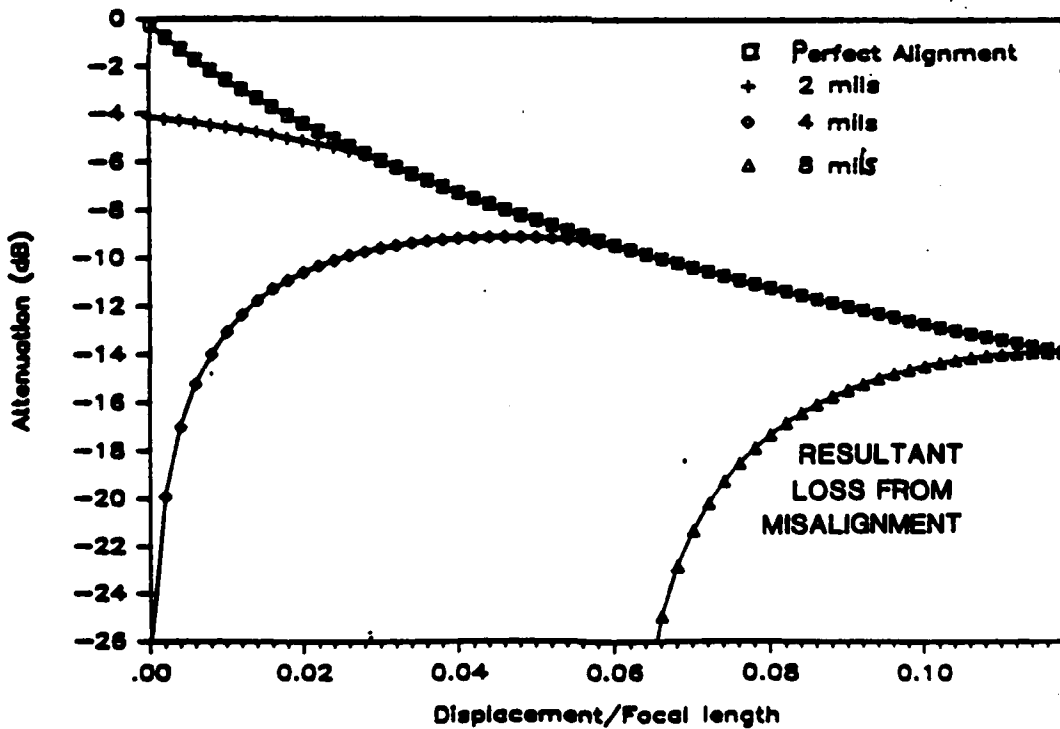
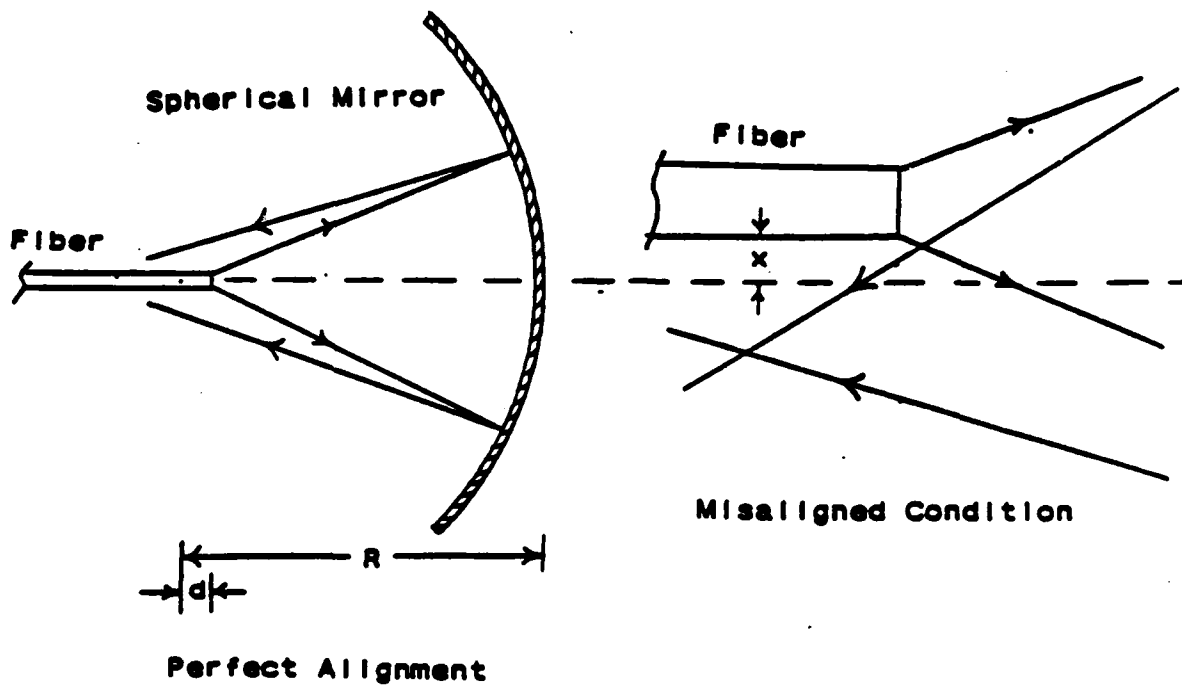

Figure 3-2. Simple Focusing Reflective Sensor

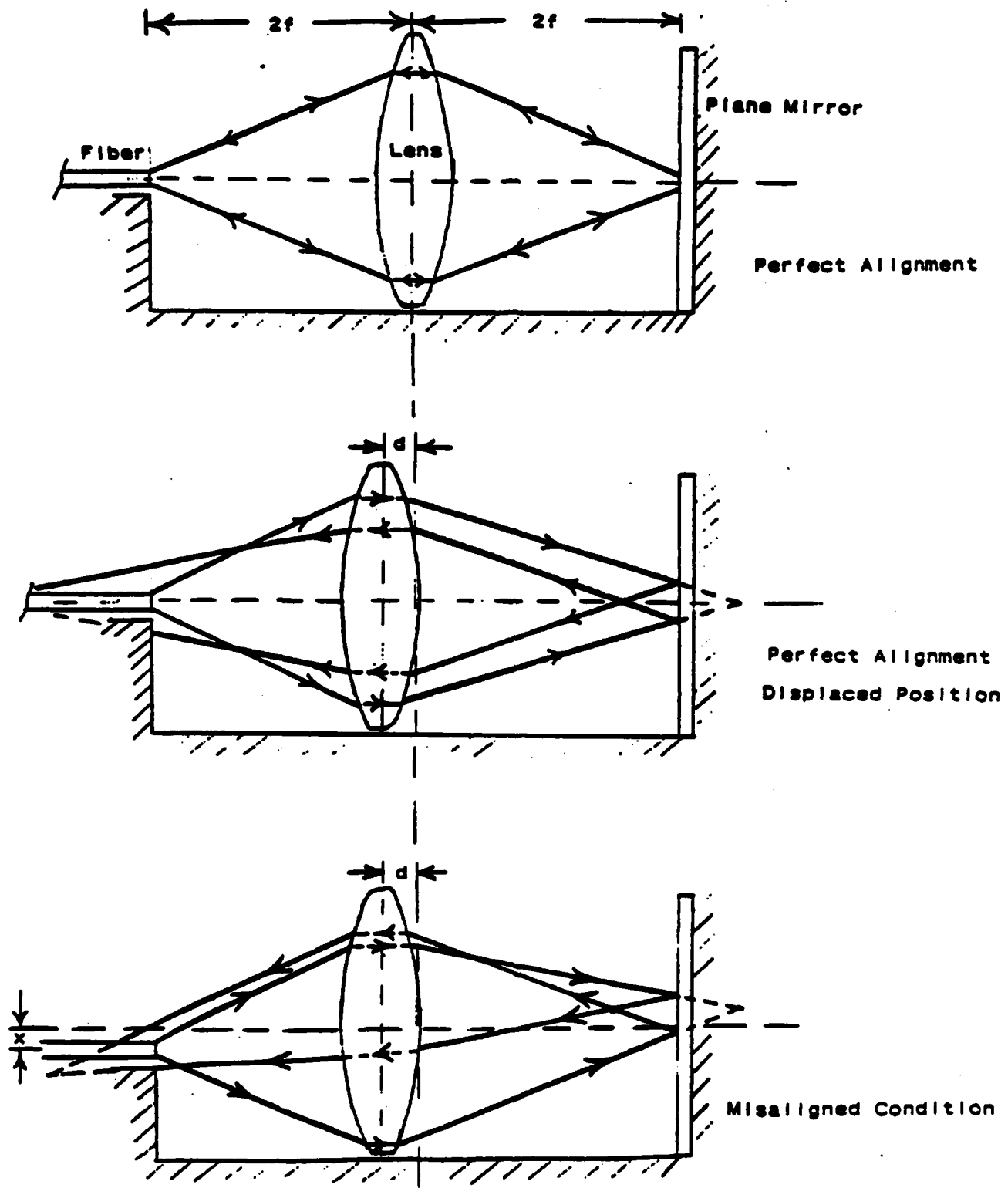

Figure 3-3. Misalignment and Vibration Insensitive Sensor

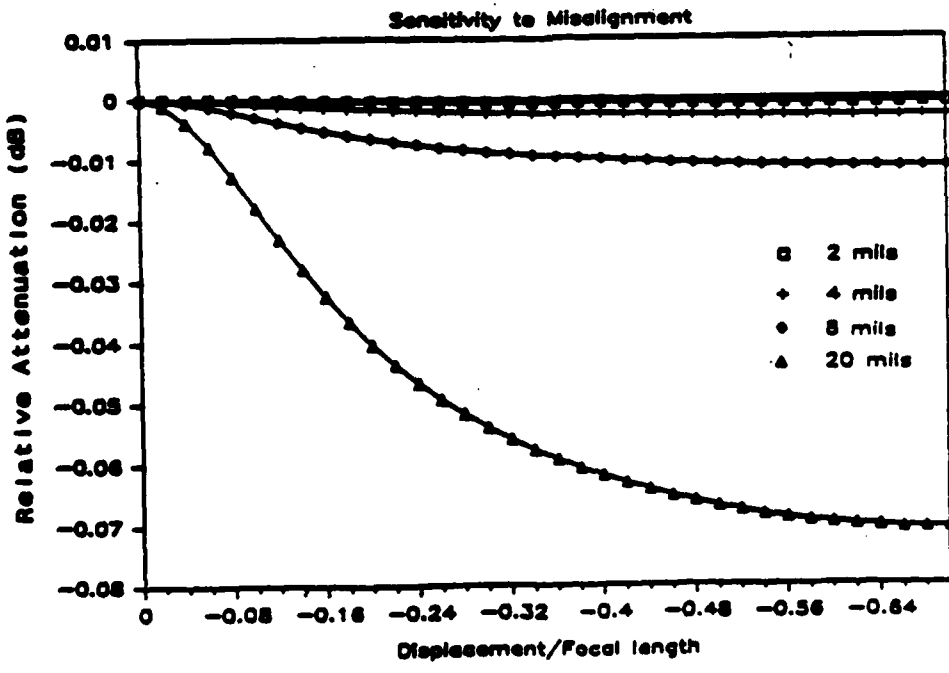
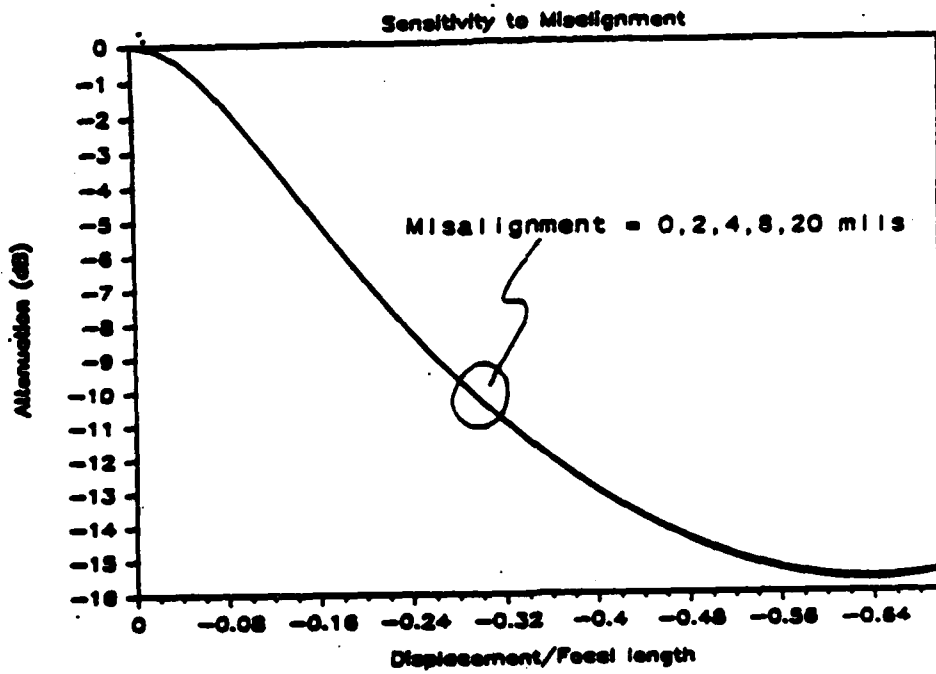
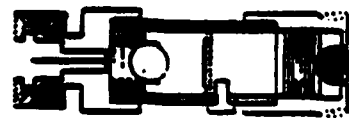
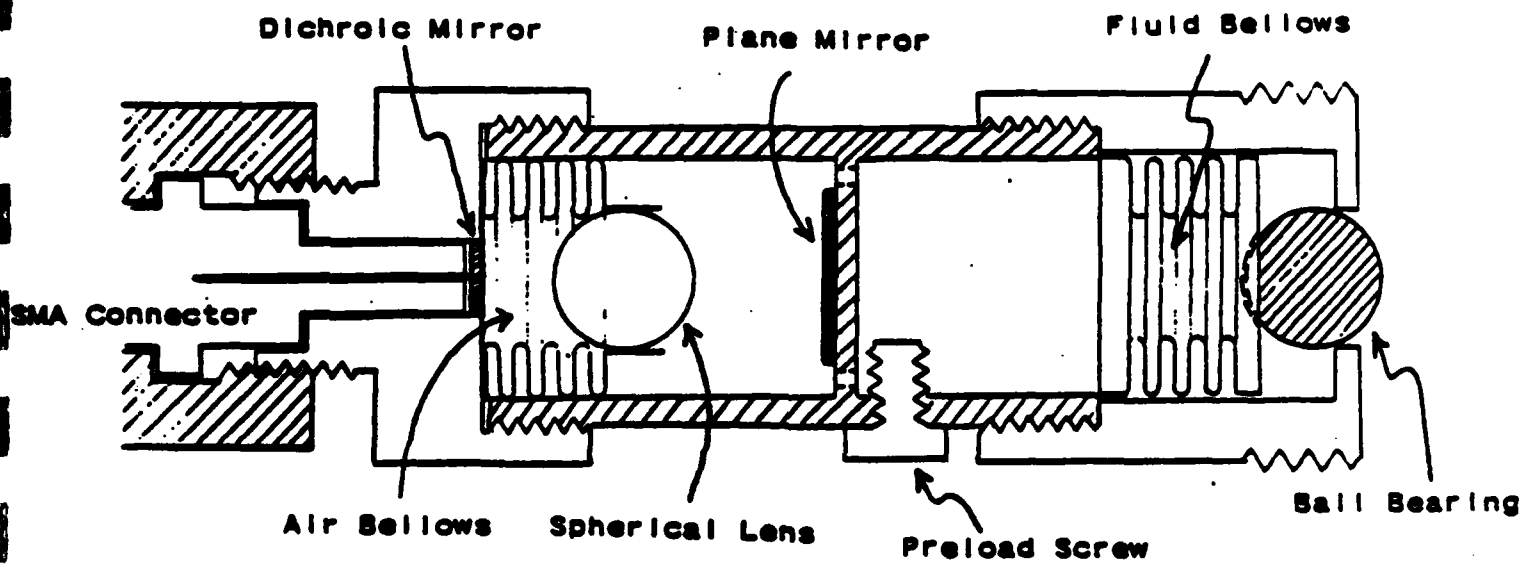

Figure 3-4. HAML Misalignment Losses



Approximate Size

Figure 3-5. Hydraulically Actuated Moving Lens Transducer

Critical to the optimum performance of the telemetry subsystem are two special components: the dichroic source unit and the sensor coupler. The source unit illuminates up to ten remote sensors with dichroic power; reference and signal. The source unit's design includes:

- Closed loop optical power regulation to ensure a constant dichroic ratio in the network;
- Dual redundant emitters to maximize reliability and utilize available throughput to double optical power;
- Test ports to verify optical and electronic performance.

The sensor coupler is critical because it facilitates redundant connection of the sensor with the network. The FBSCC, illustrated in Figure 3-6, implements this function at a third the cost of standard components with increased optical efficiency and added operational flexibility. The FBSCC's design permits up to six 100 um network fibers to be inputs, outputs or any combination of inputs and outputs. A single 200 um step index fiber, fused to the six 100 um fibers, connects to the sensor.

The Emergency Zone Monitor (EZM), shown in Figure 3-7, takes advantage of the FBSCC's redundant input/outputs to provide instant sensor access within a designated zone in the event of fire, maintenance or major network damage. It consists of simple PIN preterminated receivers and a quick-connect electrical multi-pin connector mounted in a bulkhead enclosure. A portable control/display unit connects to the EZM to simultaneously provide receiver electrical power and illumination for the zone's sensors. A single optical fiber bundle ferrule within the electrical connector mates the portable unit's laser to the sensors.

Control/Display:

The Control/Display element design design effort aimed at providing:

- Emulation of existing control and display functions;
- Advanced troubleshooting facilities and features;
- Advanced displays;
- Compatibility with existing and future Interior Communications (IC) systems.

To accomplish these goals the Control/Display design is based on a micro-computer connected as a process controller and using commercially available off-the-shelf software. The computer terminal will display network data in standard scaled units, highlighting failures and discrepancies as the Built-In Test Equipment (BITE) software detects them. A serial interface will permit data to be distributed throughout the platform via IC Systems (e.g. SDMS, Single Mode Fiber Optic Networks, etc.) to other display terminals. Local keyboard entries would be used to control the network. Alternatively commands transmitted through IC could control the network. Opto-isolated relays will be used to energize existing 110V AC indicators and alarms.

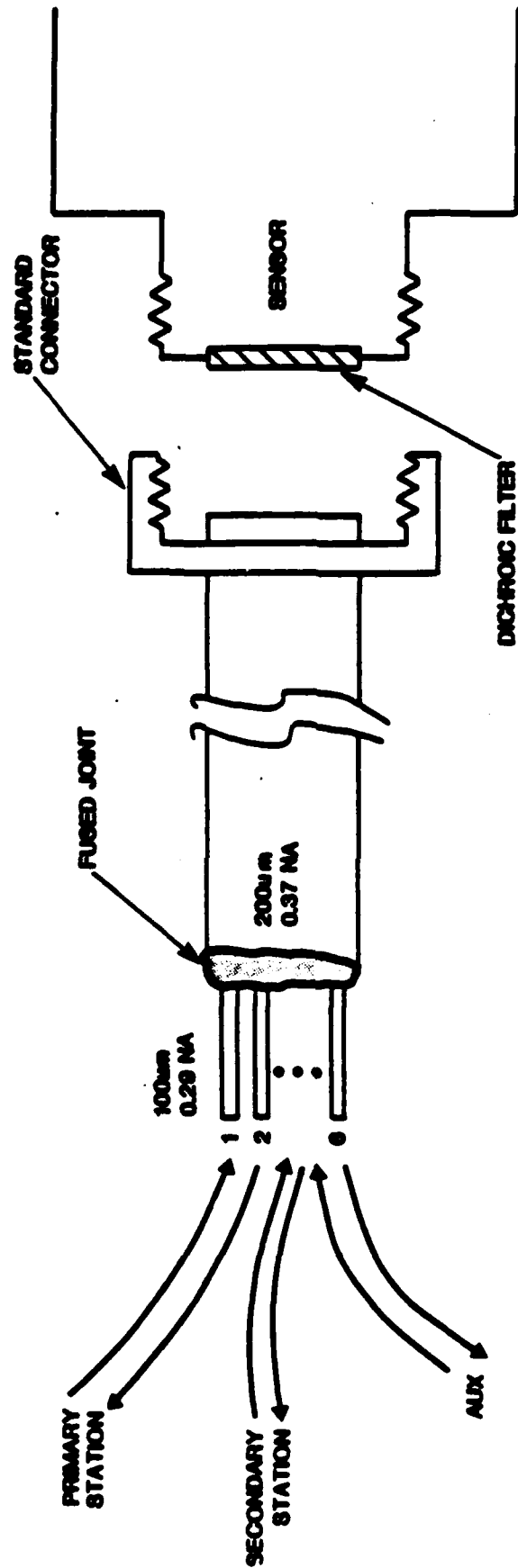

Figure 3-6. Fused Bundles Sensor Coupler/Connector

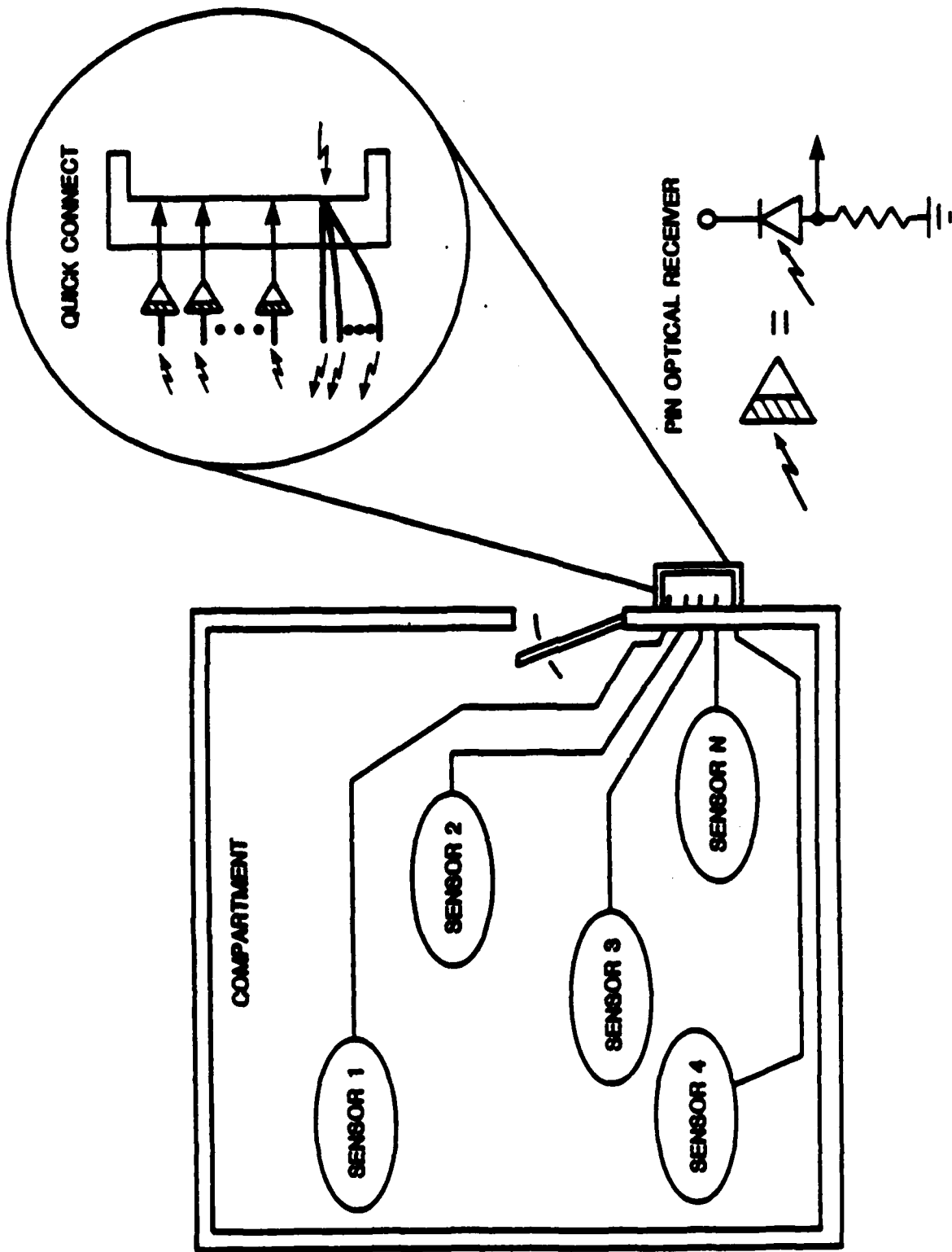

Figure 3-7. Emergency Zone Monitor

4. Summary

Recommendations and Conclusions:

To meet overall FOESS program objectives we have recommendations in two areas:

- Construction and testing of the system components.
- Investigation and evaluation of an optimum network architecture to further increase system cost savings.

Although the ultimate goal of the FOESS program is to place a prototype system aboard ship by March 1989, certain critical components not available off-the-shelf need to be fabricated and tested to characterize them and provide a performance baseline.

Construction & Testing:

Chief among the three elements are sensors compatible with the telemetry design concept and with the rigors of naval application. The concept design calls for the use of two-piece universal-transducer/conversion-module sensors, not presently available off-the-shelf.

Transducers

Two families of universal transducers, comprising four transducers, were designed during Phase I. The first family consists of the Hydraulically Actuated Moving Lens (HAML) and the Gas Attenuating Constant Volume/Pressure (GACVP) transducers. They are designed to minimize vibration and alignment sensitivity. The second family consists of the Focused Connector Moving Diaphragm (FOCMD) and the Fiber Lens Connector Switch (FLCOS) transducers. They are designed for adequate performance, low cost mass production.

Two transducers should be brass boarded, one from each family. Testing and tradeoffs should be conducted to eliminate the weakest design. The surviving design would then be carried forward through the ADM development.

Conversion Modules

One conversion module should be constructed and tested. Although this should be sufficient, fabrication of additional conversion modules would produce meaningful design data, increase the probability of success and illustrate the two-piece sensor's versatility.

Telemetry:

The dichroic source unit and the Fused Bundle Sensor Coupler Connector (FBSCC) are key untested telemetry components that facilitate Optical Dichroic Ratiometry (ODR) and simple, low cost signal path redundancy. While the concepts for these components are straight forward, they should be constructed and characterized to provide a performance baseline and to evaluate any possible production difficulties.

We suggest that one source unit and two FBSCC be built during this Phase.

Controls

The minimum amount of controls (hardware and software) must be developed to ensure proper test and evaluation results.

Investigation and Evaluation:

While evaluating the tradeoff results it became apparent that cable costs could be further reduced by replacing the present centralized sensor architecture with one consisting of distributed intelligent control/processor nodes. This would reduce cable length and improve the utilization of fiber bandwidth by limiting the length of cables carrying low bandwidth signals. The low cost nodes would include simple opto-electronic, signal processing and local control functions. Present IC circuits or high speed data buses would carry the control and data signals over redundant paths between the nodes and network control/display terminals. Evaluation of this concept would establish its worth and help set preliminary standards that will ensure compatibility with other similar distributed shipboard networks.

END

9-87

Dtic