

AD-A183 289

MODIFICATION OF LUBRICANT TRACTION MEASURING DEVICE(U)  
UNIVERSAL ENERGY SYSTEMS INC DAYTON OH S K SHARMA  
16 JAN 87 AFMAL-TR-86-4031 F33615-82-C-50001

1/1

UNCLASSIFIED

F/G 11/8

NL

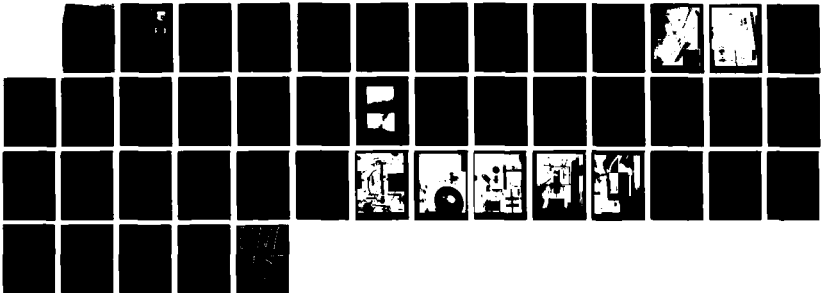

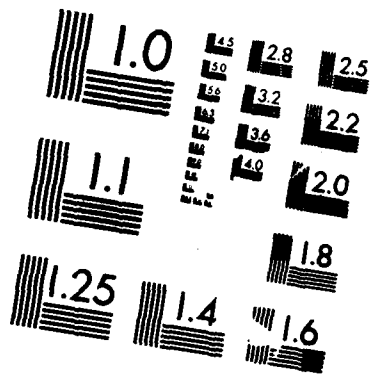

MICROCOPY RESOLUTION TEST CHART  
NATIONAL BUREAU OF STANDARDS-1963-A

2

DTIC FILE COPY

AFWAL-TR-86-4031



MODIFICATION OF LUBRICANT TRACTION  
MEASURING DEVICE

Shashi K. Sharma  
Universal Energy System, Inc.  
4401 Dayton-Xenia Road  
Dayton, OH 45432

DTIC  
ELECTE  
AUG 12 1987  
S D  
CD

AD-A183 289

January 1987

Final Report for Period October 1983 - July 1984

Approved for public release; distribution unlimited

MATERIALS LABORATORY  
AIR FORCE WRIGHT AERONAUTICAL LABORATORIES  
AIR FORCE SYSTEMS COMMAND  
WRIGHT-PATTERSON AIR FORCE BASE, OHIO 45433-6533

87 7 28 196

UNCLASSIFIED

SECURITY CLASSIFICATION OF THIS PAGE

A183289

## REPORT DOCUMENTATION PAGE

1a. REPORT SECURITY CLASSIFICATION UNCLASSIFIED			1b. RESTRICTIVE MARKINGS			
2a. SECURITY CLASSIFICATION AUTHORITY			3. DISTRIBUTION/AVAILABILITY OF REPORT Approved for public release; distribution release.			
2b. DECLASSIFICATION/DOWNGRADING SCHEDULE						
4. PERFORMING ORGANIZATION REPORT NUMBER(S) None			5. MONITORING ORGANIZATION REPORT NUMBER(S) AFWAL-TR-86-4031			
6a. NAME OF PERFORMING ORGANIZATION Universal Energy Systems, Inc.		6b. OFFICE SYMBOL (If applicable)	7a. NAME OF MONITORING ORGANIZATION Materials Laboratory (AFWAL/MLBT)			
6c. ADDRESS (City, State and ZIP Code) 4401 Dayton-Xenia Road Dayton, Ohio 45432			7b. ADDRESS (City, State and ZIP Code) Air Force Wright Aeronautical Laboratories AFSC Wright-Patterson AFB, OH 45433-6533			
8a. NAME OF FUNDING/SPONSORING ORGANIZATION Materials Laboratory		8b. OFFICE SYMBOL (If applicable) AFWAL/MLBT	9. PROCUREMENT INSTRUMENT IDENTIFICATION NUMBER F33615-82-C-5001			
8c. ADDRESS (City, State and ZIP Code)			10. SOURCE OF FUNDING NOS.			
			PROGRAM ELEMENT NO.	PROJECT NO.	TASK NO.	WORK UNIT NO.
11. TITLE (Include Security Classification) Modification of Lubricant Traction Measuring Device			61102F	2307	P1	16
12. PERSONAL AUTHOR(S) Shashi K. Sharma						
13a. TYPE OF REPORT Final		13b. TIME COVERED FROM 10-83 TO 7-84		14. DATE OF REPORT (Yr., Mo., Day) 1987 January 16		15. PAGE COUNT 45
16. SUPPLEMENTARY NOTATION						
17. COSATI CODES			18. SUBJECT TERMS (Continue on reverse if necessary and identify by block number)			
FIELD	GROUP	SUB. GR.				
11	08		Traction Rig			
14	02		Disc Load Calibration			
19. ABSTRACT (Continue on reverse if necessary and identify by block number)						
This report describes the mechanical problems faced in the operation of the traction rig from October 1983 through April 1984, along with the modifications carried out to solve them. The calibration of disc load versus the applied load is also reported.						
20. DISTRIBUTION/AVAILABILITY OF ABSTRACT UNCLASSIFIED/UNLIMITED <input checked="" type="checkbox"/> SAME AS RPT. <input type="checkbox"/> DTIC USERS <input type="checkbox"/>			21. ABSTRACT SECURITY CLASSIFICATION UNCLASSIFIED			
22a. NAME OF RESPONSIBLE INDIVIDUAL B. D. McConnell			22b. TELEPHONE NUMBER (Include Area Code) (513) 255-9033		22c. OFFICE SYMBOL AFWAL/MLBT	

## TABLE OF CONTENTS

	PAGE
1.0 INTRODUCTION	1
2.0 TRACTION RIG DESCRIPTION	2
3.0 PROBLEMS AND MODIFICATIONS	8
3.1 Torque Sensor Male Spline	8
3.2 Test Disc Retaining Nut Failure	8
3.2.1 Failure	8
3.2.2 Failure Analysis	16
3.2.3 Remedies/Modifications	16
3.3 Translating Spindle Support Mechanism	18
4.0 DISC LOAD CALIBRATION, REAR END OF TRANSLATING SPINDLE RESTRAINED	21
4.1 Calibration, Gear Coupling and Face Plate Removed	22
4.1.1 Raw Data	23
4.1.2 Reduced Data	24
4.2 Calibration, Gear Coupling and Face Plate Attached	22
4.2.1 Raw Data	25
4.2.2 Reduced Data	26
5.0 DISC LOAD CALIBRATION, REAR END OF TRANSLATING SPINDLE NOT RESTRAINED	38

Accession For	
NTIS CRA&I	<input checked="" type="checkbox"/>
DTIC TAB	<input type="checkbox"/>
Unannounced	<input type="checkbox"/>
Justification	
By _____	
Date (Month/Day/Year)	
Availability Codes	
List	Avail and/or Special
A-1	



## LIST OF ILLUSTRATIONS

FIGURE		PAGE
2.1	Simple Two Disc Design for the Study of Lubricant Characteristics	3
2.2	Traction Rig, General Assembly	4
2.3a	Photograph of Traction Rig Apparatus	5
2.3b	Photograph of Traction Rig Apparatus	6
2.4	Support Spindle Assembly	7
3.1a	Torque Sensor Bracket Assembly	9
3.1b	Parts List, Torque Sensor Bracket Assembly	10
3.2	Test Disc Mounting Arrangement	11
3.3	Test Disc Retaining Nut, Original	12
3.4	Test Disc Retaining Nut, Modified	13
3.5	High Speed Test Disc Support Shaft	14
3.6	Inboard Solder Ring	15
3.7	Tie Bolt	17
3.8	Translating Spindle Support, Deflection Test	20
4.1	Translating Spindle Support Mechanism Set Up	27
4.2	Disc Load Calibration, Set Up	28
4.3	Disc Load Calibration, Set Up	29
4.4	Disc Load Calibration, Set Up	30
4.5	Disc Load Calibration, Set Up	31
4.6	Digital Voltmeter, Applied Load	32
4.7	Test Block (Fixed Spindle)	33
4.8	Test Block (Translating Spindle)	34
4.9	Disc Load Cell Calibration	35
4.10	Test Enclosure	36
4.11	Calibration Curve, Rear End of Translating Spindle Restrained	37

**LIST OF ILLUSTRATIONS**

<b>FIGURE</b>		<b>PAGE</b>
5.1	<b>Calibration Curve, Rear End of Translating Spindle Not Restrained</b>	39

## 1.0 INTRODUCTION

Lubricant Traction Measuring Device (Traction Rig) in the AFWAL Materials Laboratory (AFWAL/MLBT) was designed and manufactured by Shaker Research Corporation, Ballston Lake, New York under Air Force Contract F33615-79C-5051. The description of the original design can be found in R. L. Smith's "Development of a Lubricant Traction Measuring Device," AFWAL-TR-81-4102, Materials Laboratory, Air Force Wright Aeronautical Laboratories, Wright-Patterson Air Force Base, Ohio, September, 1981.

In the original design, the operation of the traction rig was primarily manual with provisions for automatic data logging but without anticipating and traction rig operation was completely automated and computerized by the University of Dayton Research Institute under the Air Force contract No. F33615-82-C-5019. The detailed description of these systems are listed in UDR-TR-84-19, dated 1 December 1983.

Other modifications made to the original equipment are listed in Bruce Schreiber's "Traction Rig Operation/Modifications/Specification," University of Dayton Research Institute, Dayton, Ohio report #UDR-TR-83-125, October 1983.

Mechanical difficulties were also encountered during operation of the traction rig. Original torque sensor (0-100 in-lb) was replaced with a 150-in-oz capacity torque sensor to improve accuracy of measurements. Gear coupling connecting the translating spindle and the transmission failed due to excessive misalignment and had to be replaced. The above changes took place before October 1983.

The purpose of this document is to record the mechanical problems faced in operation of the traction rig from October 1983 to April 1984 and the modification carried out to solve them. Calibration of disc load versus the applied load is also reported,

## 2.0 TRACTION RIG DESCRIPTION

Traction Rig is designed around the use of two independently driven crowned cylindrical discs to impinging parallel spin axis, as shown schematically in Figure 2.1.

A plan view of traction apparatus is shown in Figure 2.2. Photographs of the traction rig are shown in Figure 2.3a and 2.3b. The basic mechanical apparatus consists of the following:

- a. Two Spindles for Mounting Test Discs      Item #4 in Figure 2.2  
(Figure 2.4)
- b. Two Test Discs      Item #24 in Figure 2.4
- c. One Pneumatic Loading Mechanism      Item #61 in Figure 2.2
- d. One Applied Load Sensor      Item #63 in Figure 2.2
- e. One Torque Sensor      Item #62 in Figure 2.2
- f. Two Drive Transmissions with Motors
- g. Gear Coupling Connecting Spindle      Item #15 in Figure 2.2  
to transmission

Assembly drawing of spindles is shown in Figure 2.4. Spindle G2 is fixed whereas spindle G1 can translate horizontally on linear ball bushings and guide shafts (Items 30 and 31/Figure 2.2) and provides the desired normal load via the pneumatic loading system. The spindle is connected to the drive transmission through a gear coupling. (Item 15, Figure 2.2)

A peristaltic-type variable speed pump is used to circulate the lubricant between the test enclosure bottom and the inlet to test discs. A heating element wrapped around the lubricant inlet tubing maintains the lubricant inlet temperature.

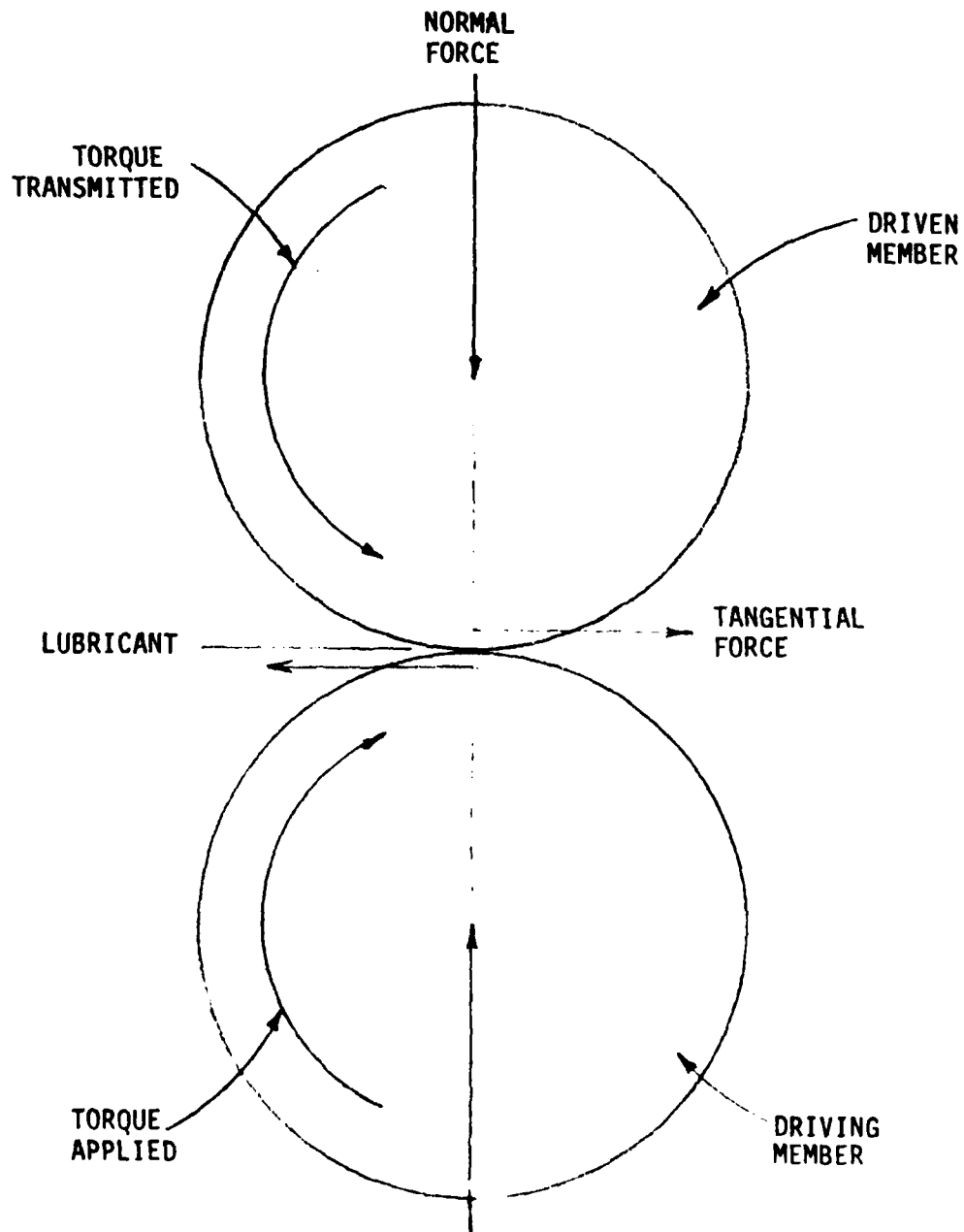

$$\text{TRACTION COEFFICIENT} = \frac{\text{TANGENTIAL FORCE}}{\text{NORMAL FORCE}}$$

Figure 2.1. Simple Two-Disk Design for the Study of Lubricant Characteristics

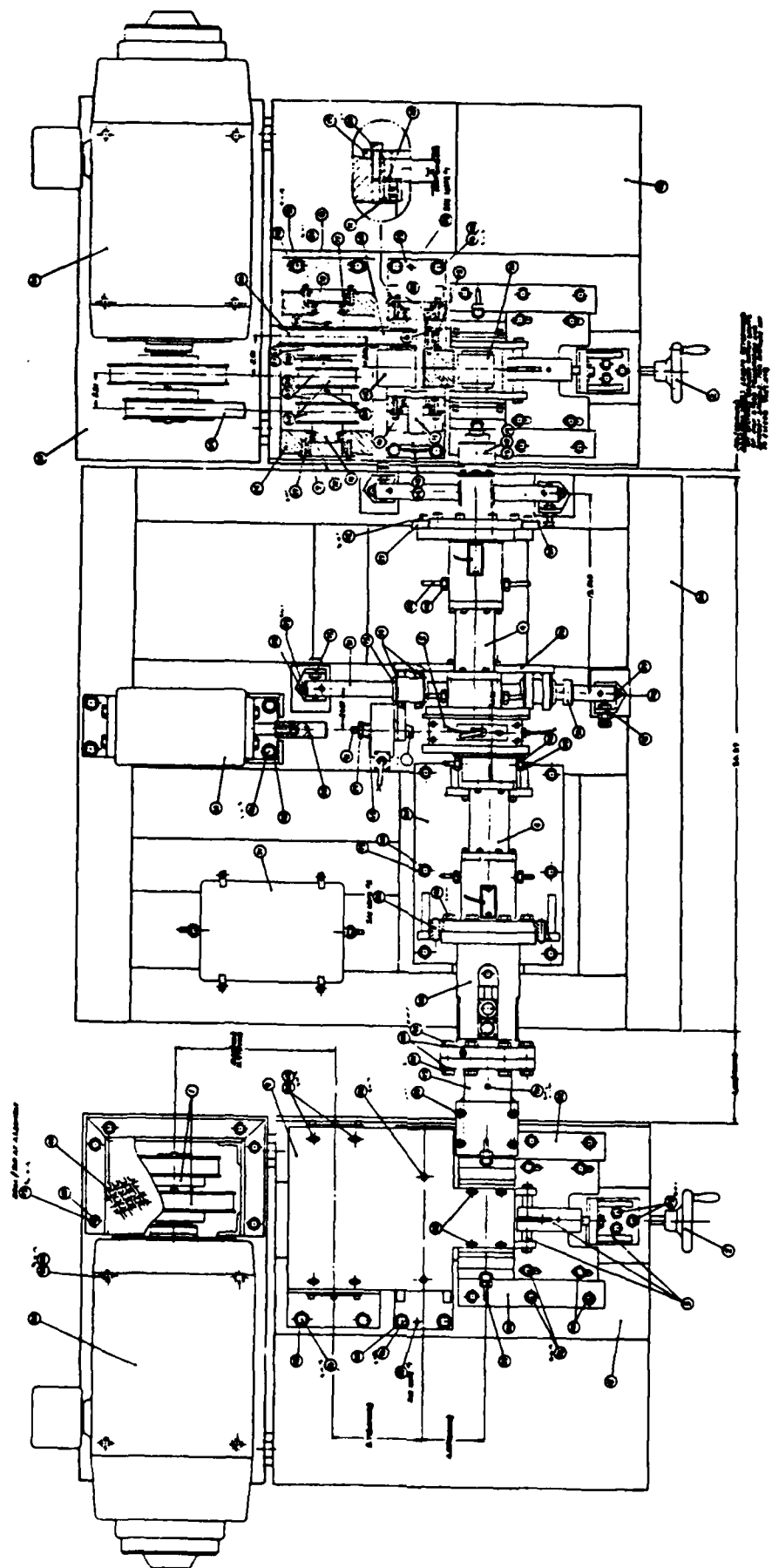
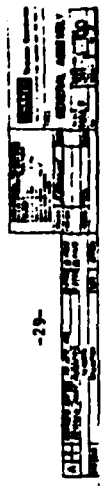
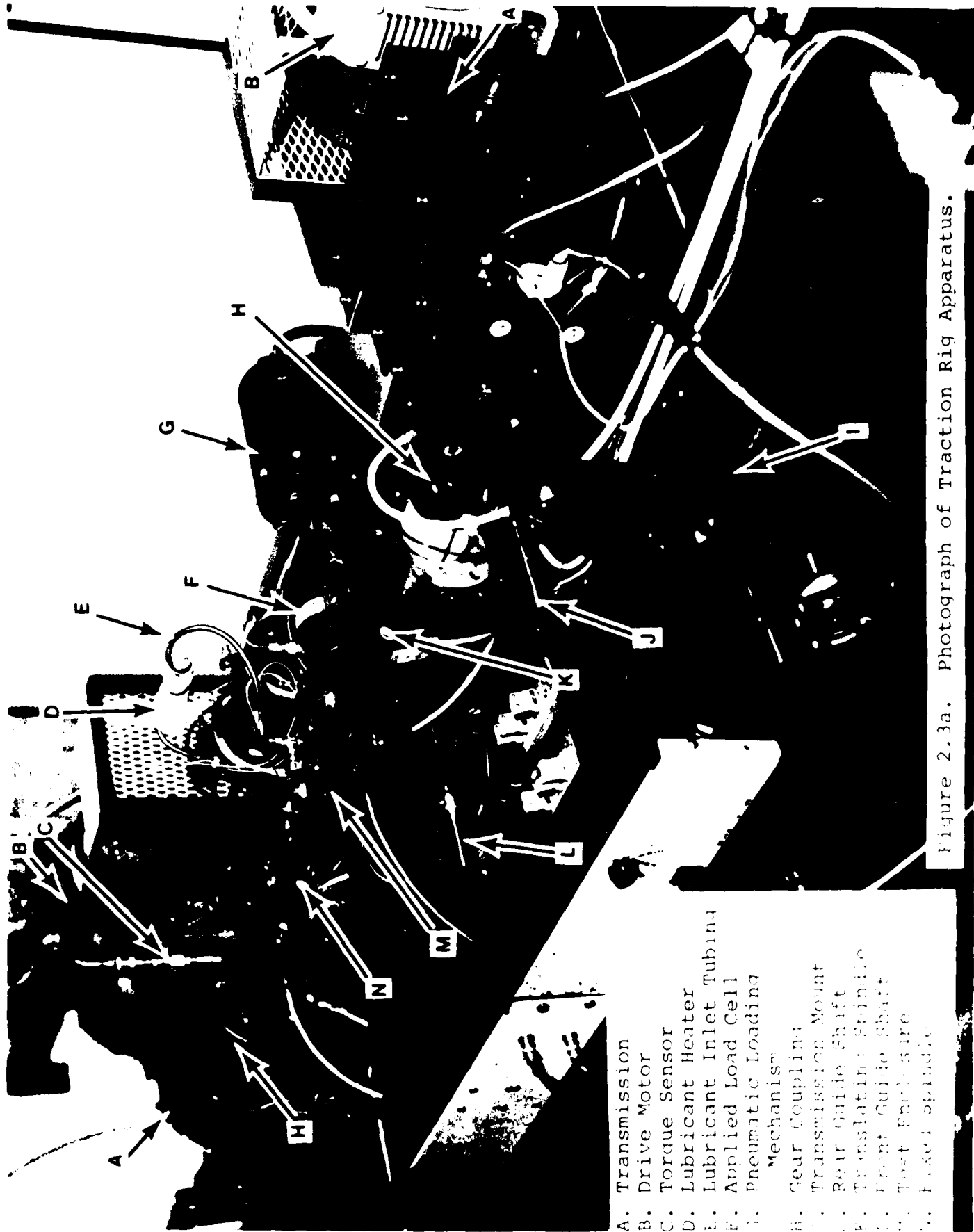

Figure 11  
Plan View of Traction Apparatus

Figure 2.2. Traction Rig, General Assembly.

-29-





- A. Transmission
- B. Drive Motor
- C. Torque Sensor
- D. Lubricant Heater
- E. Lubricant Inlet Tubing
- F. Applied Load Cell
- G. Pneumatic Loading Mechanism
- H. Gear Coupling
- I. Transmission Mount
- J. Rear Guide Shaft
- K. Translating Spindle
- L. Front Guide Shaft
- M. Test Fixture
- N. Fixed Spindle

Figure 2.3a. Photograph of Traction Rig Apparatus.

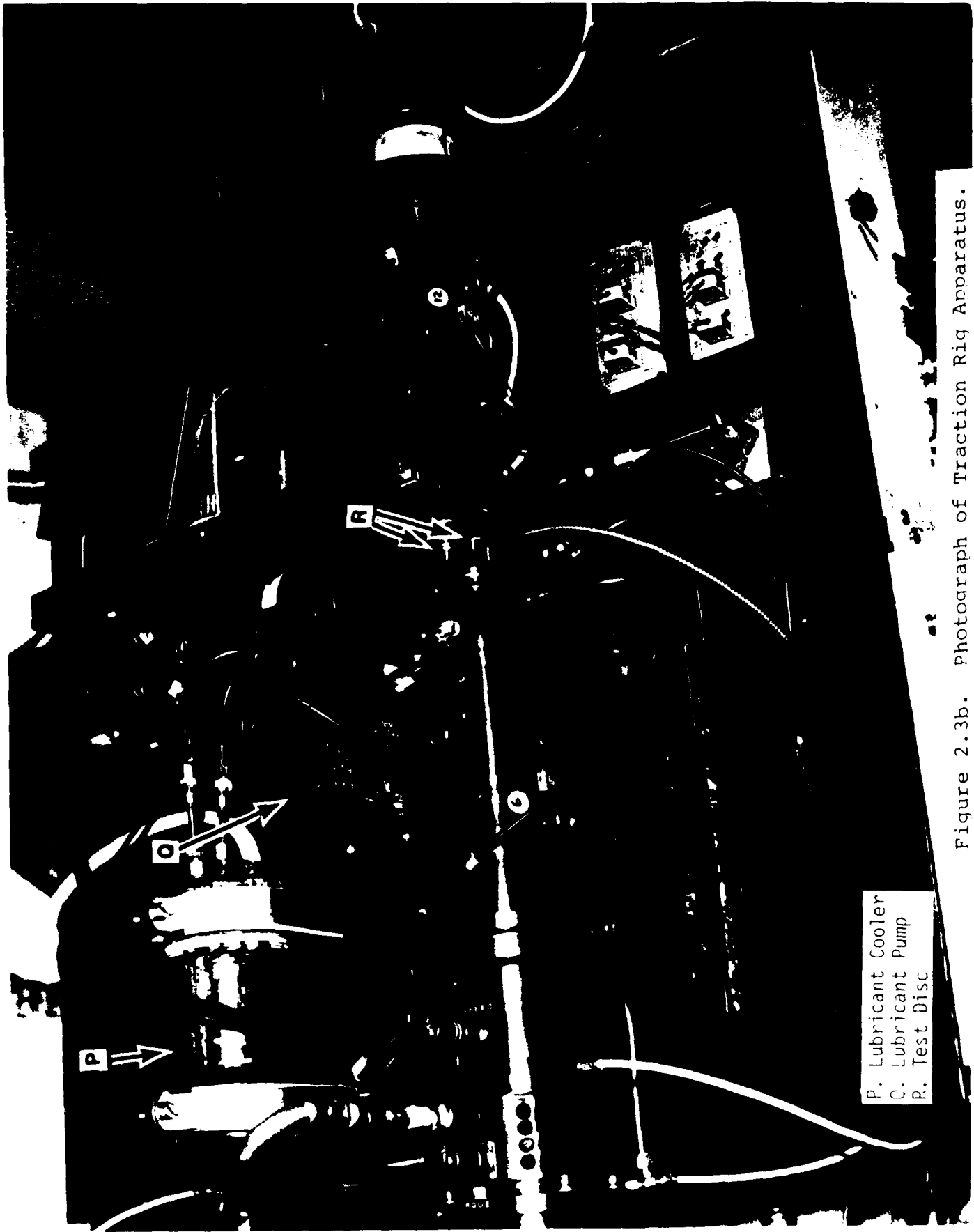

Figure 2.3b. Photograph of Traction Rig Apparatus.

P. Lubricant Cooler  
C. Lubricant Pump  
R. Test Disc

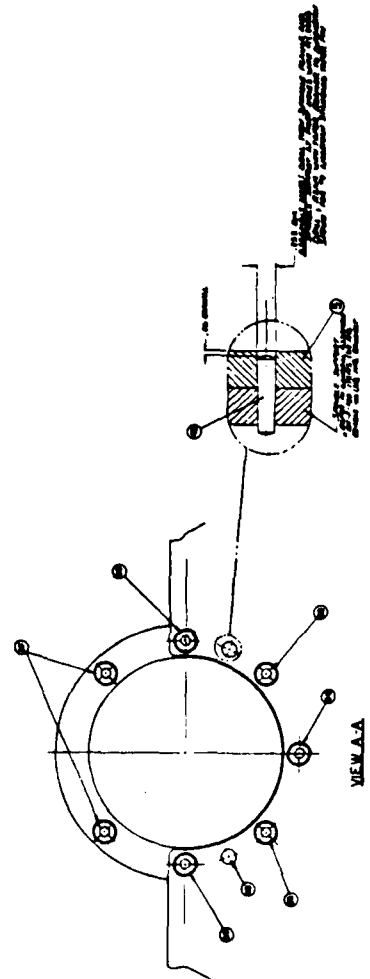
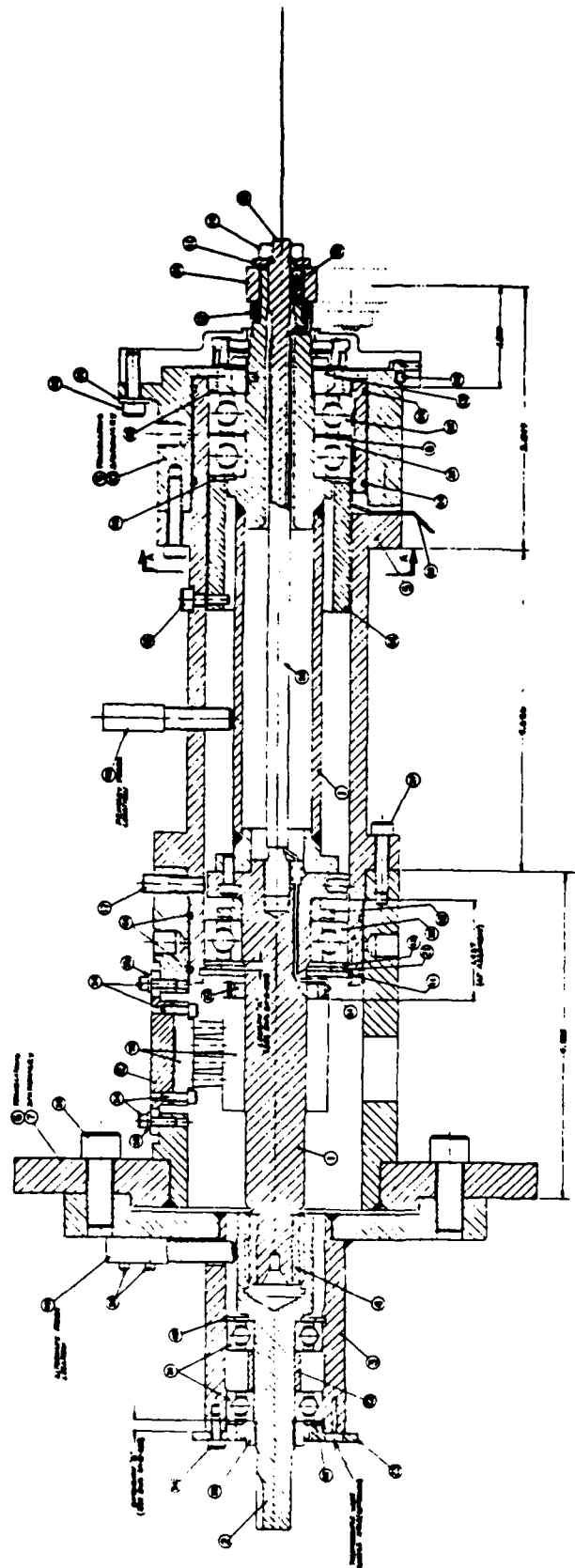

Figure 2.4. Support Spindle Assembly.

### 3.0 PROBLEMS AND MODIFICATIONS

The problems encountered with the traction equipment, their analysis, and modifications made to solve them are listed in detail.

#### 3.1 Torque Sensor Male Spline

Torque sensor bracket assembly is shown in Figure 3.1. A # 6-32, 0.18-inch-long set screw (Item 10) holds the male spline (Item A) onto the torque sensor shaft. The set screw came loose causing excessive play between torque sensor shaft and the male spline.

The set screw was tightened after applying Loctite 290 to its threads.

#### 3.2 Test Disc Retaining Nut Failure

##### 3.2.1 Failure

Figure 3.2 shows the arrangement used for mounting the test disc onto the translating spindle. Similar arrangement is used for the fixed spindle except that the spacer is not used. Note that Figure 2.4 does not show the actual mounting arrangement used. The original Retaining Nut is shown in Figure 3.3 and Figure 3.4 shows the Modified Retaining Nut.

During one of the experiments, the Retaining Nut on the Translating Spindle came loose, causing excessive chattering noise. The test was discontinued and the following damage was noticed.

(1) Helicoil threads in the Retaining Nut (Figure 3.3) on the Translating Spindle and Fixed Spindle damage.

(2) Both test discs (52100 steel, 35" crown radius, 1.125" dia., 0.500" thick) showed tremendous amounts of wear.

(3) Plasma spray on Translating spindle (Figure 3.5) chipped off at some places, along with some scratches due to spinning of the test disc on the spindle.

(4) Glass ceramic on the inboard solder ring was damaged. (Item 1/Figure 3.6)

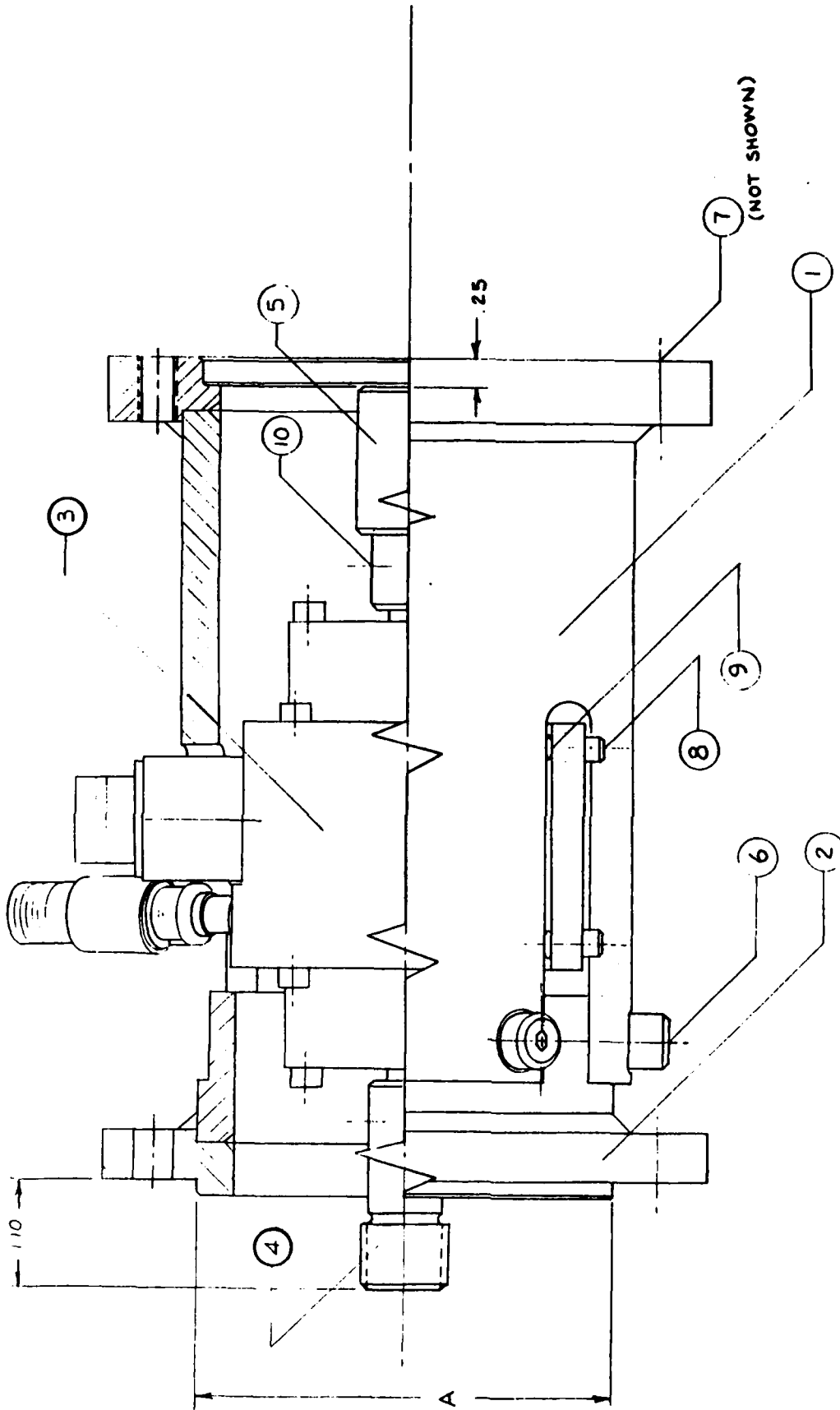

NOTE:  
 DIAMETERS "A" AND "B" TO BE CONCENTRIC  
 WITH TORQUE SENSOR SHAFT  $\phi$   
 WITHIN .0005 T.I.R

Figure 3.1a. Torque Sensor Bracket Assembly.

QUANTITY	ITEM	PART NUMBER	DESCRIPTION	MATERIAL
2	10		6-32 UNF-2A x 3/16 SOCKET HEAD SET SCREW	18-8 STAINLESS
4	9		O-RING 1/4 I.D. x .09 WIDE	BUNA-N
4	8		10-32 UNF-2A x 1/8 LONG SOCKET HEAD SCREW	18-8 STAINLESS
6	7		3/8-24 UNF-2A x 1 1/4 LONG SOCKET HEAD SCREW	18-8 STAINLESS
5	6		3/8-24 UNF-2A x 5/8 LONG SOCKET HEAD SCREW	18-8 STAINLESS
1	5	311-C-078	FEMALE SPLINE	
1	4	311-C-077	MALE SPLINE	
1	3	1602-200	TORQUE SENSOR -LEBOW ASSOC	
1	2	-D-079-2	BRACKET END	
1	1	311-J-079-1	BRACKET BODY	
<p><b>TITLE:</b> TORQUE SENSOR BRACKET ASSY</p> <p><b>SCALE:</b> DRAWING NUMBER: 311-D-080</p> <p><b>DIMENSIONAL TOLERANCES UNLESS OTHERWISE SPECIFIED</b>  DECIMALS: 2 PLACES +.01  3 PLACES +.005  FRACTIONS +1/32  ANGLES +1/2°  SURFACE FINISH 125  REMOVE SHARP CORNERS  REMOVE ALL BURRS</p> <p><b>DRAWN:</b> <i>R. R. R.</i> 20 FEB 83</p>				
			SHEET	OF
			REV	

Figure 3.1b. Parts List, Torque Sensor Bracket Assembly.

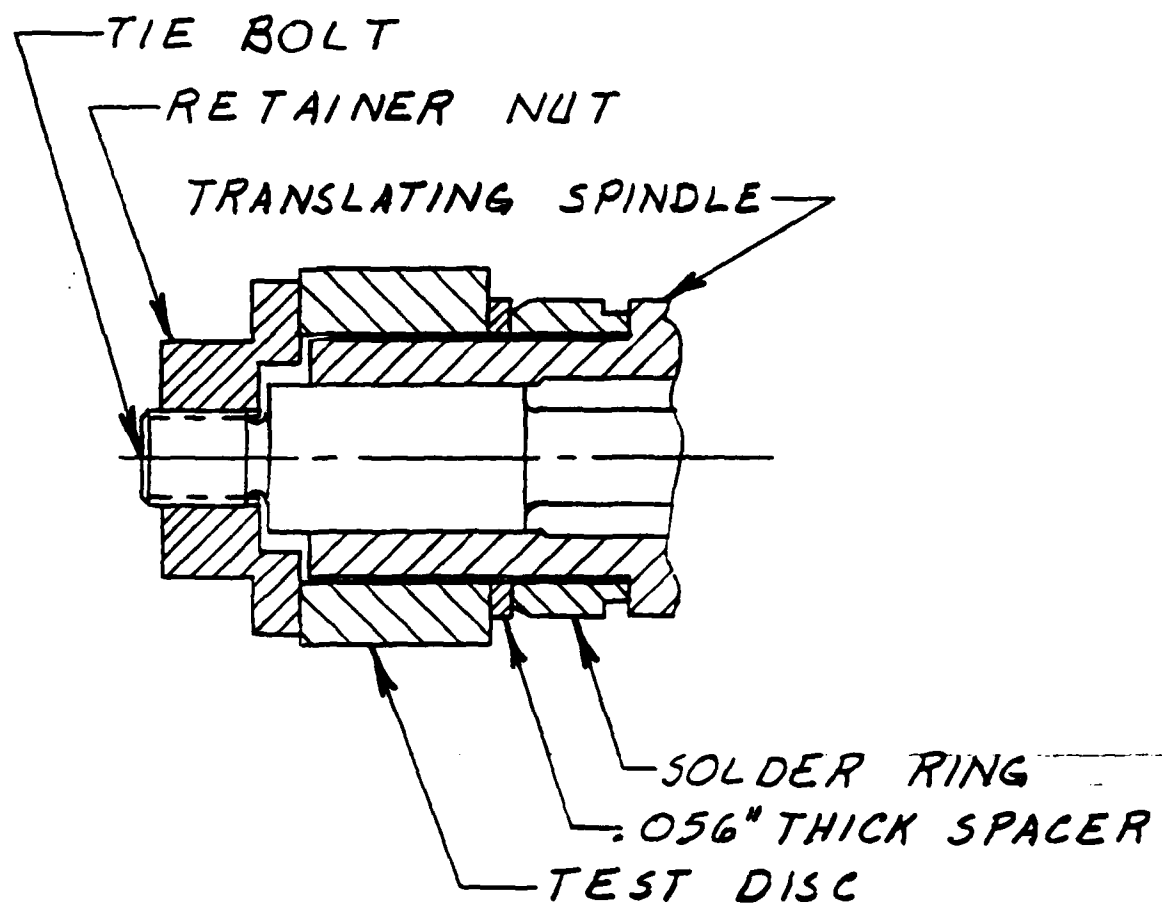
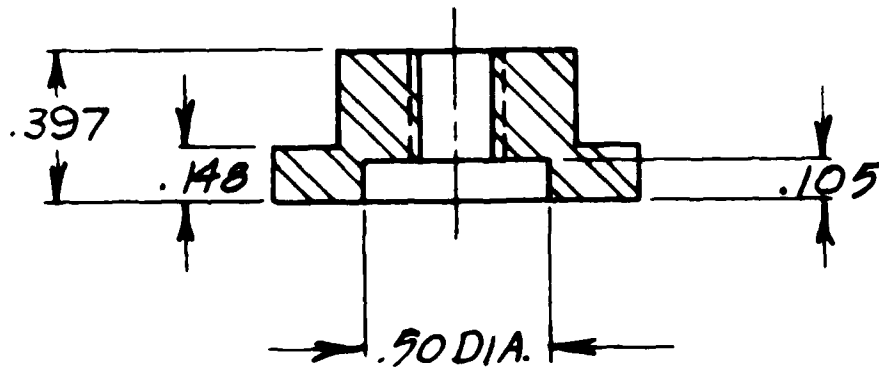
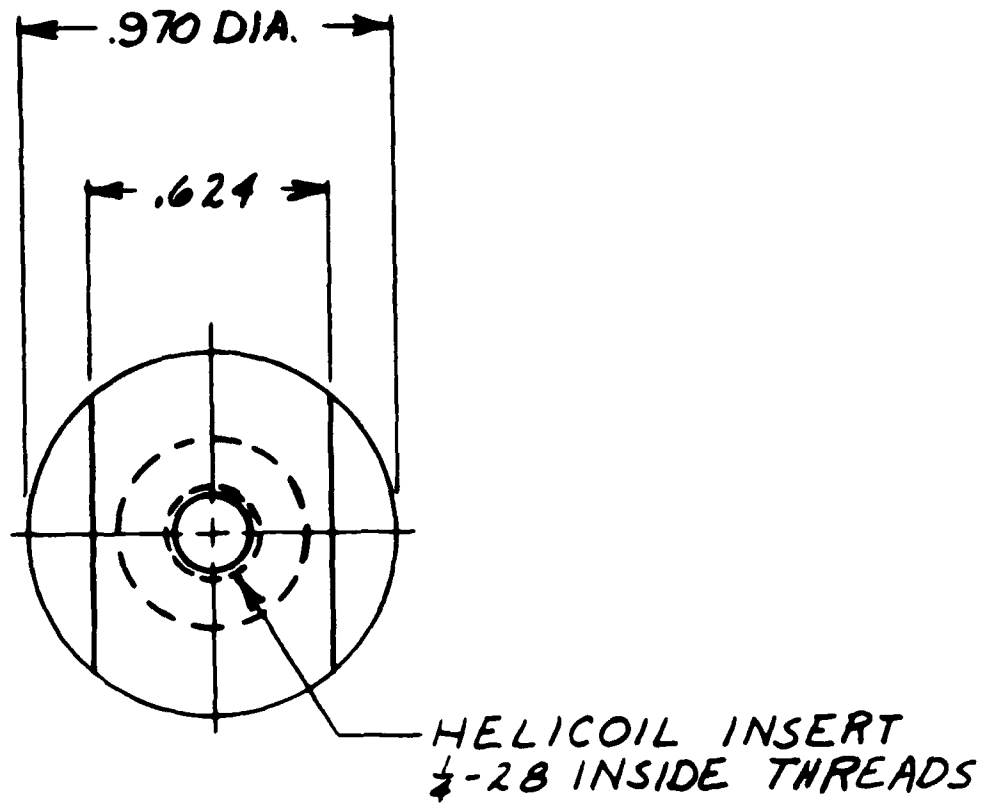
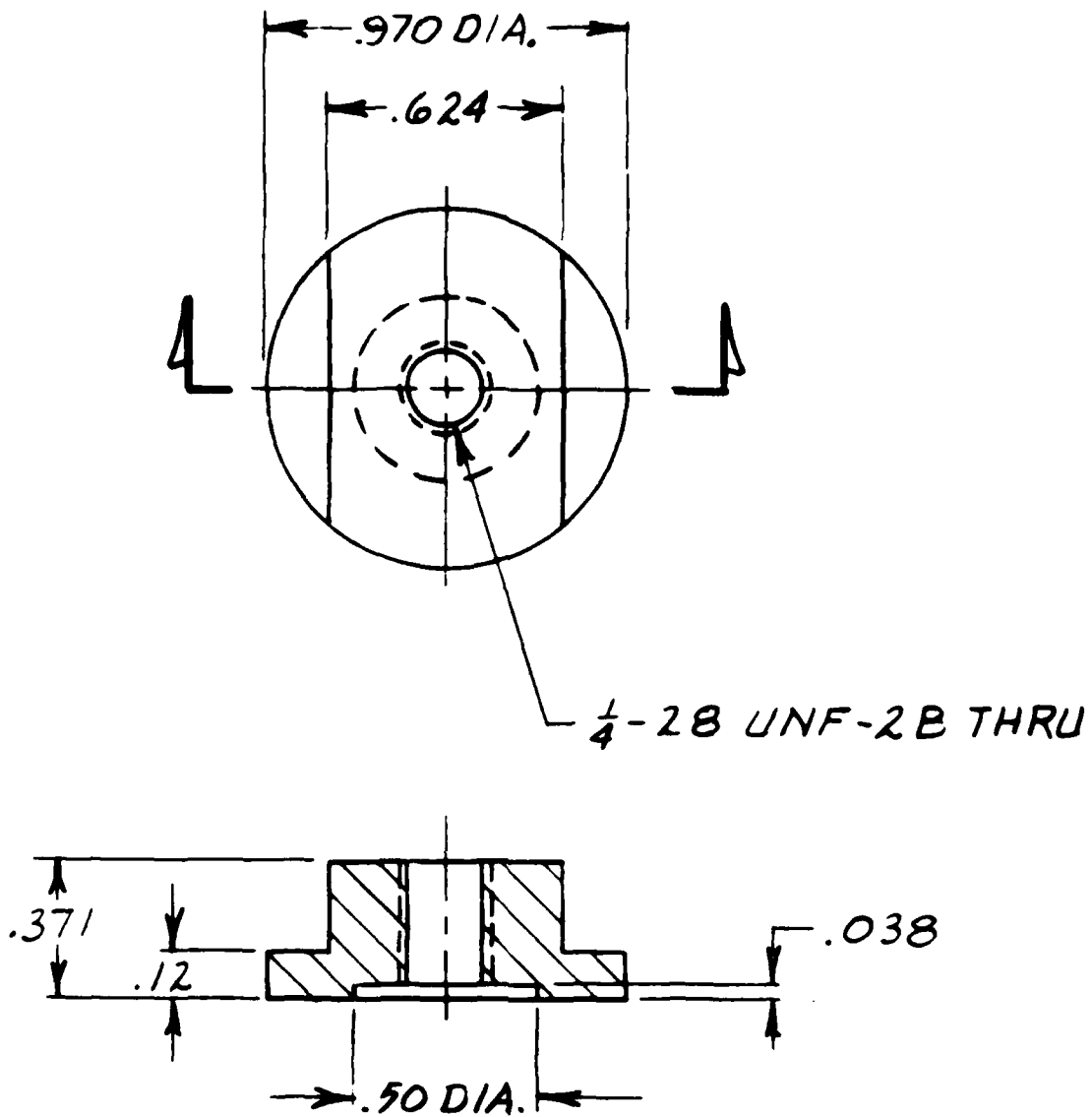

Figure 3.2. Test Disc Mounting Arrangement.



MATERIAL - ALUMINUM

Figure 3.3. Test Disc Retaining Nut, Original.



MATERIAL: - 17-4 PH H-1100  
 STAINLESS STEEL

Figure 3.4. Test Disc Retaining Nut, Modified.

Plasma Sprayed  
Ceramic Coated Shaft



Test  
Disk

Test Disk and Support Shaft

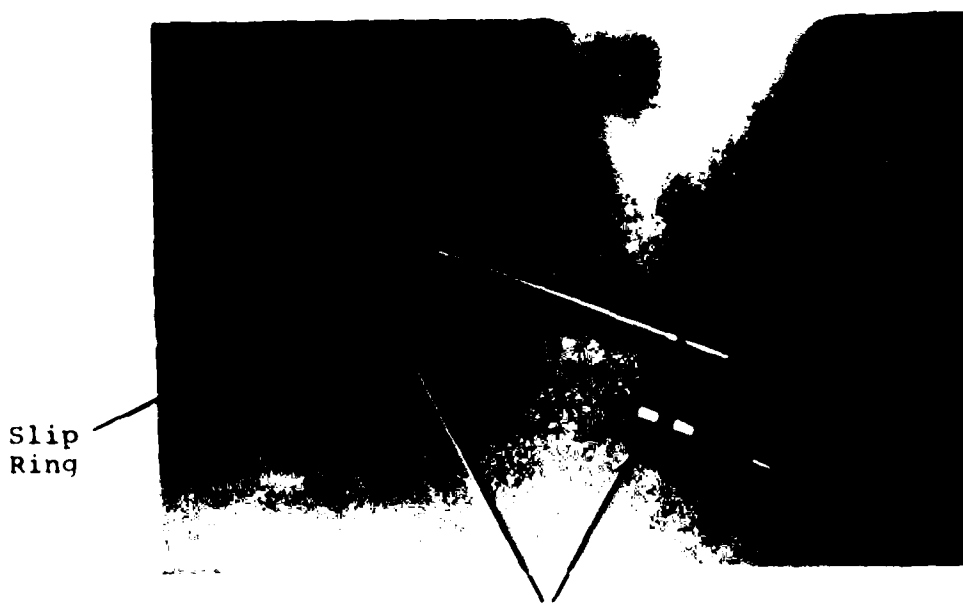

Electrically  
Conducting Wire  
Through Shaft

Slip  
Ring

Support Bearings

Figure 3.5. High Speed Test Disk Support Shaft.

# MATERIAL LIST

NO	QTY	DESCRIPTION
1	1	CORNING "MACOR" MACHINABLE CERAMIC
2	1	BRASS - CDA 260 & HARD

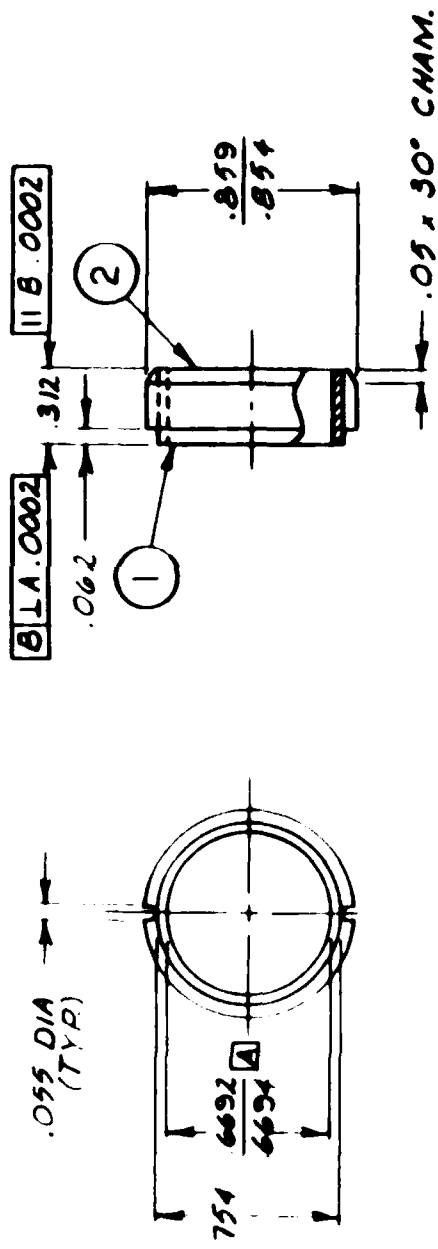

NOTE: BOND ITEM #1 TO  
ITEM #2 WITH EASTMAN 910,  
OR HIGH TEMPERATURE EPOXY.  
- MACHINE TO SIZE.

SHAKER RESEARCH  
CORPORATION

TITLE:	INBOARD SOLDER RING
SCALE:	DRAWING NO 2 / 1 311-B-04C
REV:	

Figure 3.6. Inboard Solder Ring

### 3.2.2 Failure Analysis

The following might have caused the above mentioned failures.

(1) Helicoil threads in the retaining nut on the translating spindle were damaged due to over tightening, reduced thread engagement and absence of any locking mechanism.

Since no torque wrench was used to tighten the retaining nut, these could have been easily overtorqued. Recommended torque for this helicoil insert (per Helicoil bulletin 1000) is only 30 in-lb. The Tie bolt is made out of 4340 Alloy Steel Rc28-32, for which minimum tensile strength is approximately 120,000 psi (Figure 3.2 and 3.7). Catalog recommended torque for 1/4 - 28 threads for such material is 90 in-lb (see Unbrako Catalog page 9). A gross mismatch between the strengths of tie bolts threads and the retaining nut threads is clearly evident.

The length of the helicoil insert in the retaining nut should have been 1.50 x diameter instead of hardly 1 x diameter as designed.

Thread engagement between the tie bolt and the retaining nut, on translating spindle was further reduced due to the use of 0.056 thick spacer (Figure 3.2) between the solder ring and the test disc. This spacer was used to align the two test disks with each other. Moreover, the thickness of the spacer varied from 0.056 to 0.0575 which meant the faces were not parallel, thereby affecting the clamping of the test disc.

(2) Other damage listed in 3.2.1 was a result of retaining nut failure.

### 3.2.3 Remedies/Modifications

(1) New tie bolt (Figure 3.7) was made and installed in the translating spindle. Conducting wire (Item 51) and shrink tubing (Item 53) in Figure 2.4 were not installed.

(2) New retaining nuts were made for both spindles, using 17-4 PH-H1100 stainless steel (Figure 3.4).

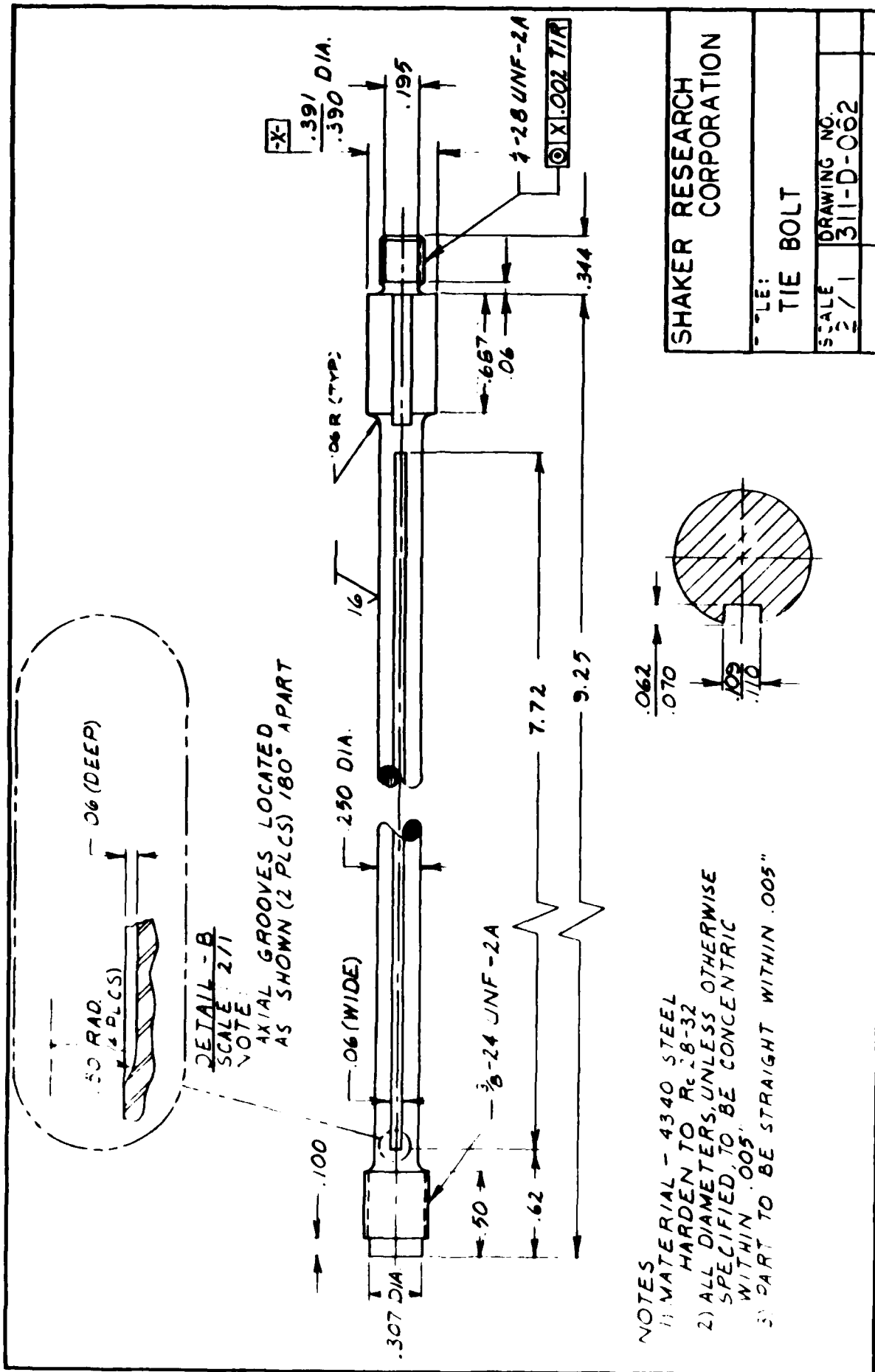

Figure 3.7. Tie Bolt.

(3) We recommend that during mounting of retaining nut onto the spindle, the threads on the tie bolt and retaining nut should be thoroughly cleaned and a drop of Loctite 290 be applied to the tie bolt threads. The retaining nuts should be torqued to 80-90 in-lb.

(4) To increase thread engagement, the 0.056-inch thick spacer was eliminated. To align the test discs, 0.056-inch thick spacers were installed between translating spindle body and support brackets (Figure 3.8 and 4.1).

### 3.3 Translating Spindle Support Mechanism

The normal load is applied to the translating spindle by means of pneumatic loading mechanism as shown in Figure 2.2. The applied load is measured by load cell (Item 63/Figure 2.2). Under ideal conditions, all of the applied load should be transmitted to the test discs. Gear coupling (Item 15/Figure 2.2) should not experience any side load. Due to some misalignment between the line of application of the load and the point of contact on the test discs and other unknown causes (deflection of various components, etc.) a moment is created by the applied load. To counterbalance this moment, a side force and lateral misalignment is caused in the gear coupling. The conditions get worse as the load and speed are increased. The excessive vibrations and side loads may have been the cause of a previous failure of a gear coupling as mentioned in section 1.0. With the gear coupling disconnected, an applied load of 150 lbf created a lateral movement of 0.010 inch at the front guide bushing and 0.070 inch at the rear guide bushing (Figure 3.8).

Apart from affecting the mechanical stability of the equipments, this setup created an error in the collected data. With the gear coupling sharing some of the applied load, the actual normal force between the test discs was NOT equal to the applied load. So any data collected under this setup should be corrected using the actual disc load and not the applied load. Disc load calibration was carried out under this setup and is reported in section 5.0.

To improve the mechanical stability of the system, we decided to restrain the lateral movement of the rear end of the spindle. A "Holo-krome two piece Clamp Tite" locking collar (1.00-in Bore) was used on the rear guide shaft as shown in Figure 4.1. To achieve repeatability for each new test or a new pair of test discs, the following setup procedure was established.

- o Remove the gear coupling (Item 15/Figure 2.2) from the translating spindle.
- o Mount the test discs on each spindle and tighten the retaining nuts to 80-90 in-lb after applying Loctite 290 to its threads.
- o Apply a normal load of 6 lbf to the test discs, through pneumatic loading mechanism.
- o Adjust the length of coil spring on the front guide shaft to 1.25 in. as shown in Figure 4.1.
- o Using a dial indicator against the rear guide bushing, tighten the split locking collar, to restrain the lateral movement of translating spindle at that point.
- o Connect the gear coupling between translating spindle and the transmission.
- o Remove dial indicator.
- o Remove 6-lbf normal load from the discs.

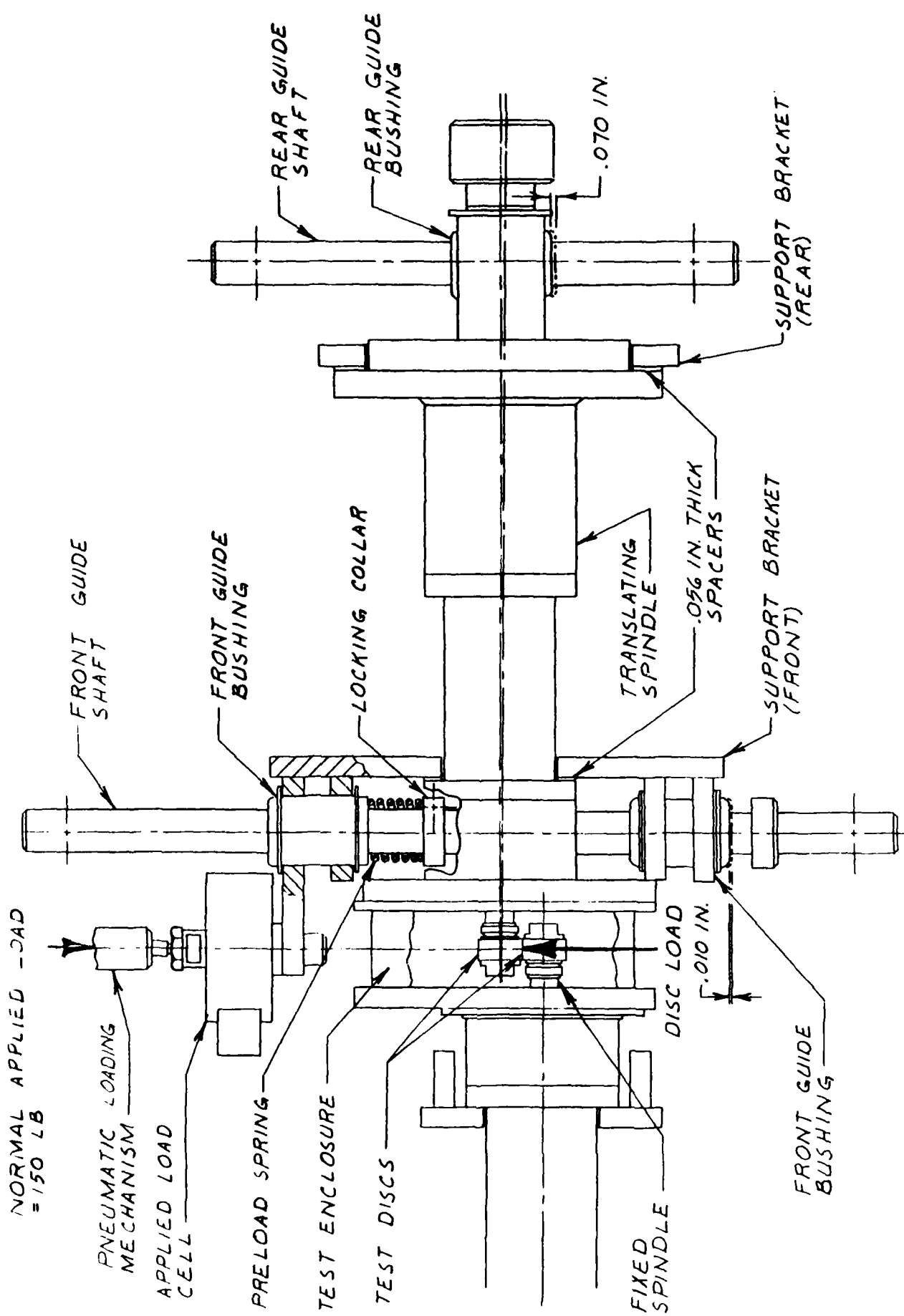

Figure 3.8. Translating Spindle Support, Deflection Test.

#### 4.0 DISC LOAD CALIBRATION, REAR END OF TRANSLATING SPINDLE RESTRAINED

As discussed in section 3.3, the normal load between the test discs is not equal to the applied load. In order to get the actual load experienced by the test discs, this calibration was carried out. A setup procedure similar to that described in 3.3 was used and gave good repeatability. In place of test discs, test blocks SK1 (Figure 4.7) and SK2 (Figure 4.8) were mounted on fixed spindle and translating spindle respectively. To measure disc load, a 'Sensotec' (Model 13/1161-17 S. No. 56703) load cell was placed between the test blocks such that similar sides of the test blocks faced each other. Using a spirit level, top faces of test blocks SK1 and SK2 were made horizontal. For this load cell, 1 MV = 22.31810742 lbf (Figure 4.9). Normal load (applied load) was applied through the pneumatic system shown in Figure 2.2 and measured by load cell (Item 63/Figure 2.2). Applied load values were based upon the calibration of this load cell using 50-lbf and 100-lbf dead weights, 1 lbf = 0.002485 Volts. Applied load was increased by increments of 25 lbf and the disc load readings (from Model 13/1161-17) were noted. Due to almost point loading between the load cell tip and test block SK2, local yielding of material occurred on the test block, which gave lower values. In subsequent loadings when the yielding of material stopped, the disc load were slightly higher with better repeatability. So the values of disc load in first data set for each center distance were not used in calibration, but are reported here for record only. Data was taken with increasing values of load, as is the case in actual testings.

To check the repeatability between different setups, after taking data under one setting, the gear coupling (Item 15/Figure 2.2) and the locking collar on rear guide shaft (Figure 4.1) were disassembled. For the next setting, complete setup procedure was followed.

Photographs of disc load calibration are shown in Figures 4.2 through 4.5. Figure 4.6 shows the digital voltmeter used to read the applied load values. Data were also taken after varying the center distance between the spindles, using different sides of

the test blocks. Nonimal gap between the faces of test blocks was 0.130 in (due to the space occupied by disc load cell). Data were taken with spindles' center distances of 1.250 in, 1.375 in and 1.500 in, which was achieved by using '\*' dimensions (Figure 4.7 and 4.8) .560, .623 and .685 respectively on the test blocks facing each other.

Face plate (Item 3/Figure 4.10) was modified to change the pilot bore dimension from 3.479 to 3.560 to eliminate any changes of its interference with translating spindle.

#### 4.1 Calibration, Gear Coupling and Face Plate Removed

For this calibration, gear coupling (Item 15/Figure 2.2) and face plate (Item 3/Figure 4.10) were removed from the translating spindle.

#### 4.2 Calibration, Gear Coupling and Face Plate Attached

For this calibration, the face plate (Item 3/Figure 4.10) was attached to the translating spindle. Gear coupling (Item 15/Figure 2.2) was also connected between the spindle and the transmission. This setup completely simulates the actual testing conditions.

The data fitted to a straight line that gave

$$\text{Disc Load} = .695 \text{ APPLIED LOAD.}$$

A plot of disc load versus the applied load is shown in Figure 4.11.

4.1.1.1. RAW DATA

DISC LOAD CELL READING (MILLIVOLTS)

1 M1111-volt = 22.31810742 lbf

Applied Load LBF	Center Distance = 1.250 IN			Center Distance = 1.375 IN			Center Distance = 1.500 IN				
	Setting #1	Setting #2	Setting #3	Setting #1	Setting #2	Setting #3	Setting #1	Setting #2	Setting #3	Setting #4	
0	0.03	0.045	0.05	0.06	0.06	0.06	0.05	0.05	0.05	0.05	0.05
25	0.76	0.81	0.83	0.70	0.76	0.76	0.82	0.88	0.88	0.88	0.88
50	1.57	1.62	1.65	1.50	1.56	1.56	1.62	1.69	1.71	1.72	1.72
75	2.36	2.43	2.45	2.29	2.38	2.38	2.39	2.48	2.51	2.52	2.52
100	3.14	3.21	3.23	3.10	3.20	3.20	3.15	3.24	3.28	3.30	3.30
125	3.88	3.96	3.97	3.87	3.99	3.99	3.88	3.97	4.01	4.03	4.04
150	4.61	4.71	4.71	4.66	4.75	4.75	4.61	4.69	4.72	4.75	4.75
175	5.34	5.43	5.42	5.46	5.45	5.48	5.35	5.43	5.43	5.46	5.46

4.1.1.2 REDUCED DATA

Applied Load LBF	DISC LOAD (LBF)												Average Disc Load LBF
	Center Distance = 1.250 IN			Center Distance = 1.375 IN			Center Distance = 1.500 IN						
	Setting #2	Setting #3	Setting #2	Setting #2	Setting #2	Setting #2	Setting #3	Setting #2	Setting #3	Setting #2	Setting #3	Setting #4	
0	0.0000	0.0000	0.0000	0.0000	0.0000	0.0000	0.0000	0.0000	0.0000	0.0000	0.0000	0.0000	0.0000
25	17.0734	17.4081	16.6270	16.9618	18.5240	18.5240	18.5240	18.5240	18.5240	18.5240	18.5240	18.5240	17.7708
50	35.1510	35.7090	35.1510	35.4858	36.6017	37.0481	37.2712	37.0481	37.2712	37.2712	37.2712	37.2712	36.2111
75	53.2287	53.5635	53.0055	53.7866	54.2330	54.9025	55.1257	54.9025	55.1257	55.1257	55.1257	55.1257	54.1214
100	70.6368	70.9716	70.6368	71.6411	71.1948	72.5338	72.5338	72.5338	72.5338	72.5338	72.5338	72.5338	71.5295
125	87.3754	87.4870	87.5986	88.8261	87.4870	88.3797	88.8261	88.3797	88.8261	88.8261	88.8261	89.0492	88.1286
150	104.1140	104.0024	104.5603	105.3415	103.5560	104.2256	104.8951	104.2256	104.8951	104.8951	104.8951	104.8951	104.4488
175	120.1830	119.8482	121.2989	121.6337	120.0714	120.0714	120.7410	120.0714	120.7410	120.7410	120.7410	120.7410	120.5736

4.2.1 RAW DATA

Applied Load LBF	DISC LOAD CELL READING (MILLIVOLTS)											
	Center Distance = 1.250 IN				Center Distance = 1.375 IN				Center Distance = 1.500 IN			
	Setting #1	Setting #2	Setting #1	Setting #2	Setting #1	Setting #2	Setting #1	Setting #2	Setting #1	Setting #2	Setting #1	Setting #2
	0.06	0.06	0.06	0.06	0.06	0.06	0.06	0.06	0.06	0.06	0.06	0.06
25	0.71	0.82	0.75	0.79	0.74	0.74	0.74	0.79	0.72	0.74	0.74	0.82
50	1.55	1.63	1.56	1.60	1.57	1.57	1.60	1.60	1.51	1.56	1.56	1.64
75	2.38	2.46	2.38	2.42	2.39	2.39	2.42	2.42	2.26	2.38	2.38	2.47
100	3.18	3.26	3.20	3.23	3.21	3.21	3.23	3.23	3.00	3.17	3.17	3.27
125	3.95	4.03	3.99	4.03	4.00	4.00	4.03	4.03	3.79	3.93	3.93	4.03
150	4.71	4.78	4.75	4.79	4.76	4.76	4.79	4.79	4.57	4.66	4.66	4.76
175	5.45	5.45	5.47	5.50	5.47	5.47	5.50	5.50	5.35	5.33	5.33	5.42

4.2.2 REDUCED DATA

Applied Load LBF	DYSC LOAD (LBF)							
	Center Distance = 1.250 IN		Center Distance = 1.375 IN		Center Distance = 1.500 IN		Average Disc Load LBF	
	Setting #1	Setting #2	Setting #1	Setting #2	Setting #1	Setting #2	Setting #1	Setting #2
0	0.00	0.00	0.00	0.00	0.00	0.00	0.00	0.00
25	16.52	16.96	15.18	16.29	15.18	16.96	15.18	16.18
50	35.04	35.49	33.70	34.37	33.48	35.26	33.48	34.56
75	53.56	54.23	52.00	52.67	51.78	53.79	51.78	53.01
100	71.42	72.09	70.30	70.75	69.41	71.64	69.41	70.94
125	88.60	88.83	87.93	88.60	86.37	88.60	86.37	88.16
150	105.34	104.67	104.90	105.56	102.66	104.90	102.66	104.67
175	120.29	119.18	120.74	121.41	117.62	119.63	117.62	119.81

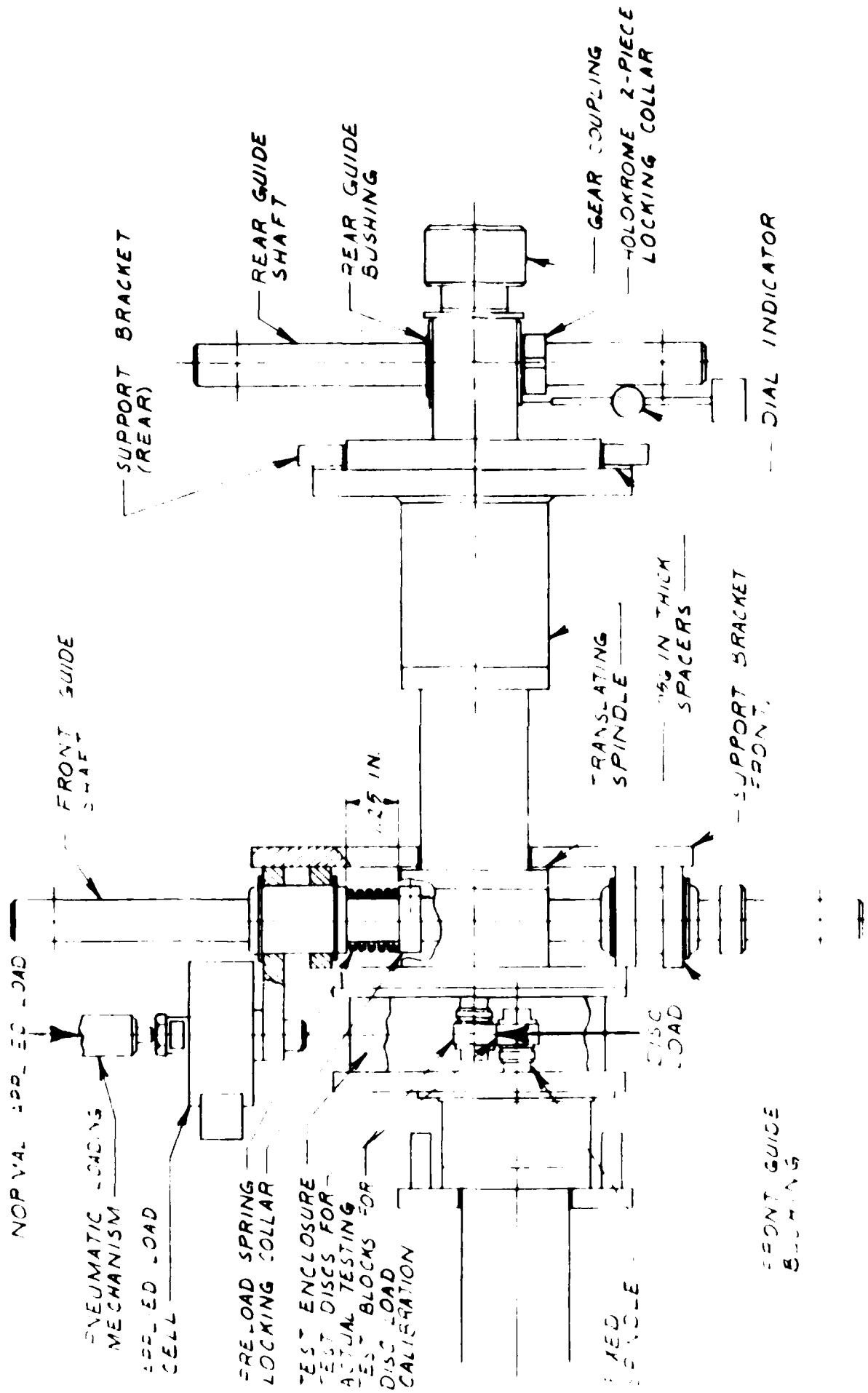

Figure 4.1. Translating Spindle Support Mechanism Set Up.

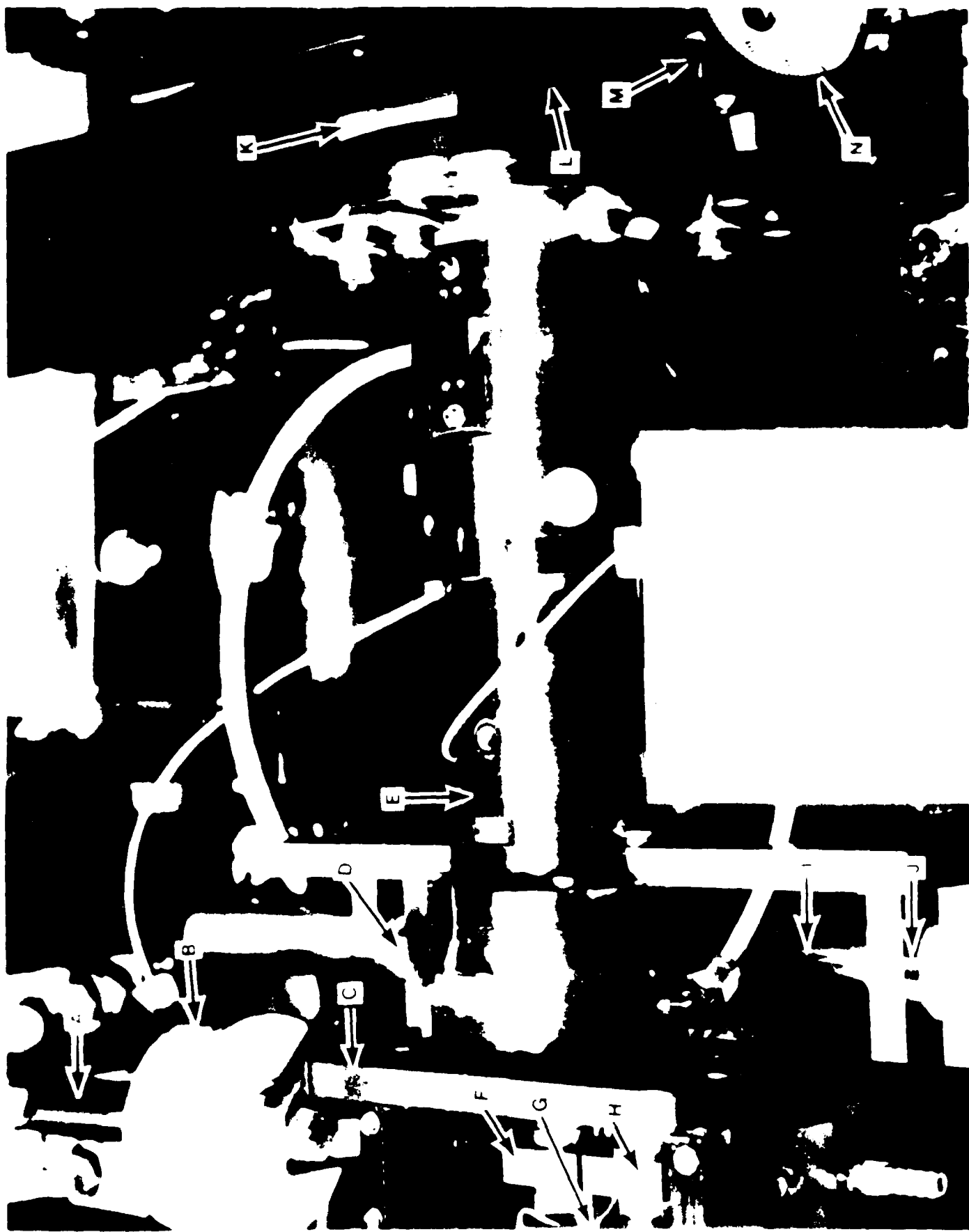
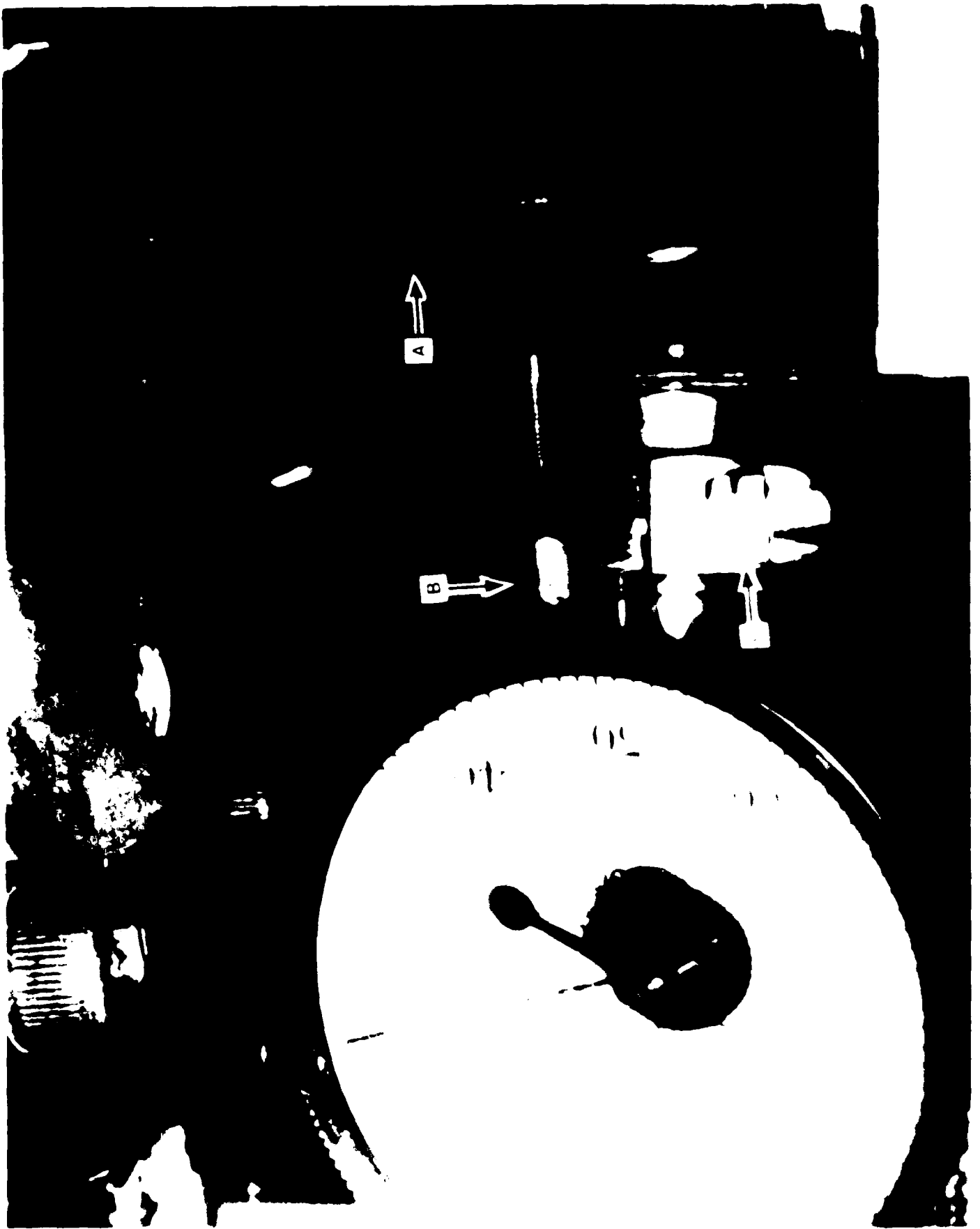
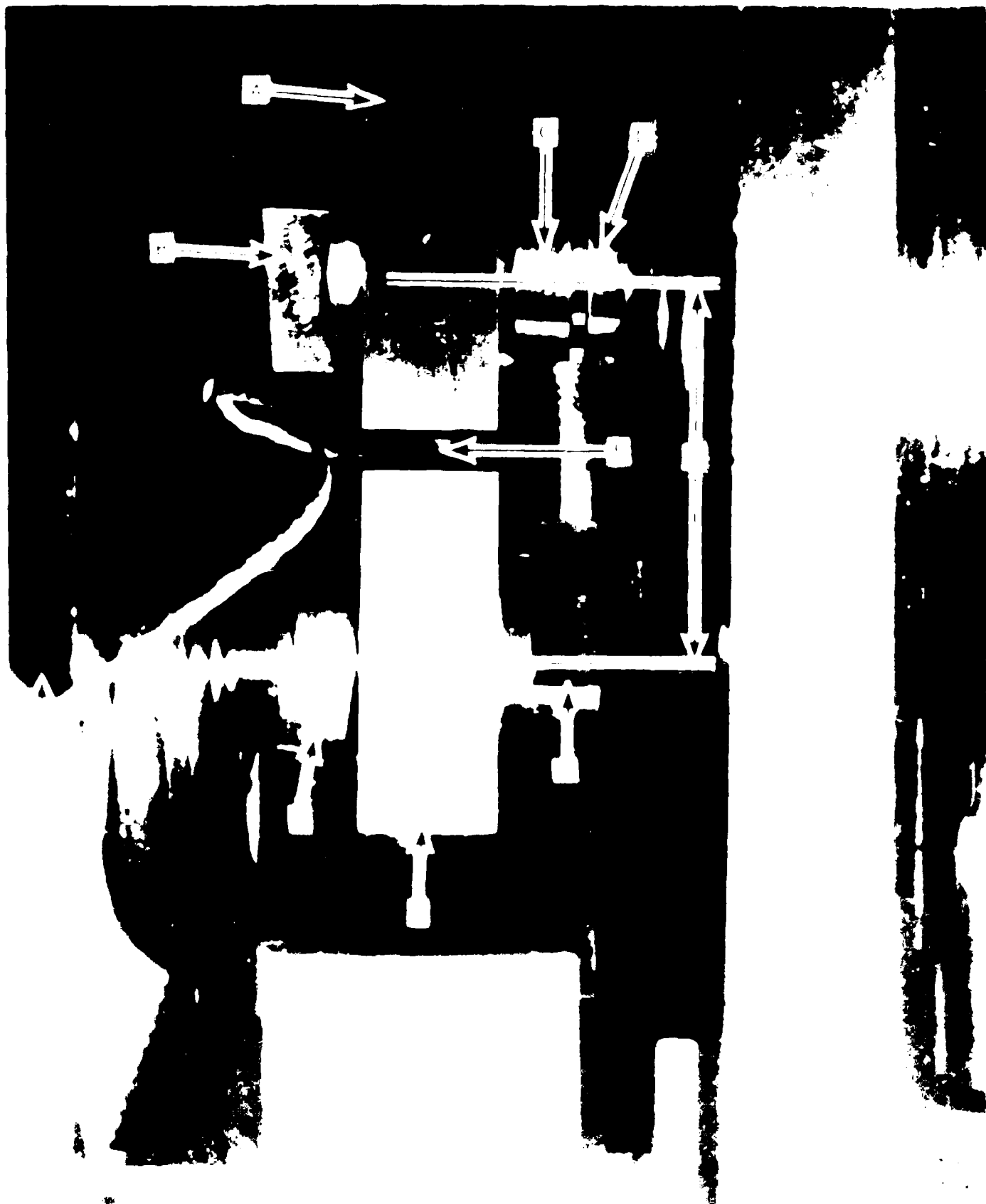

FIG. 1.2. Free load calibration.









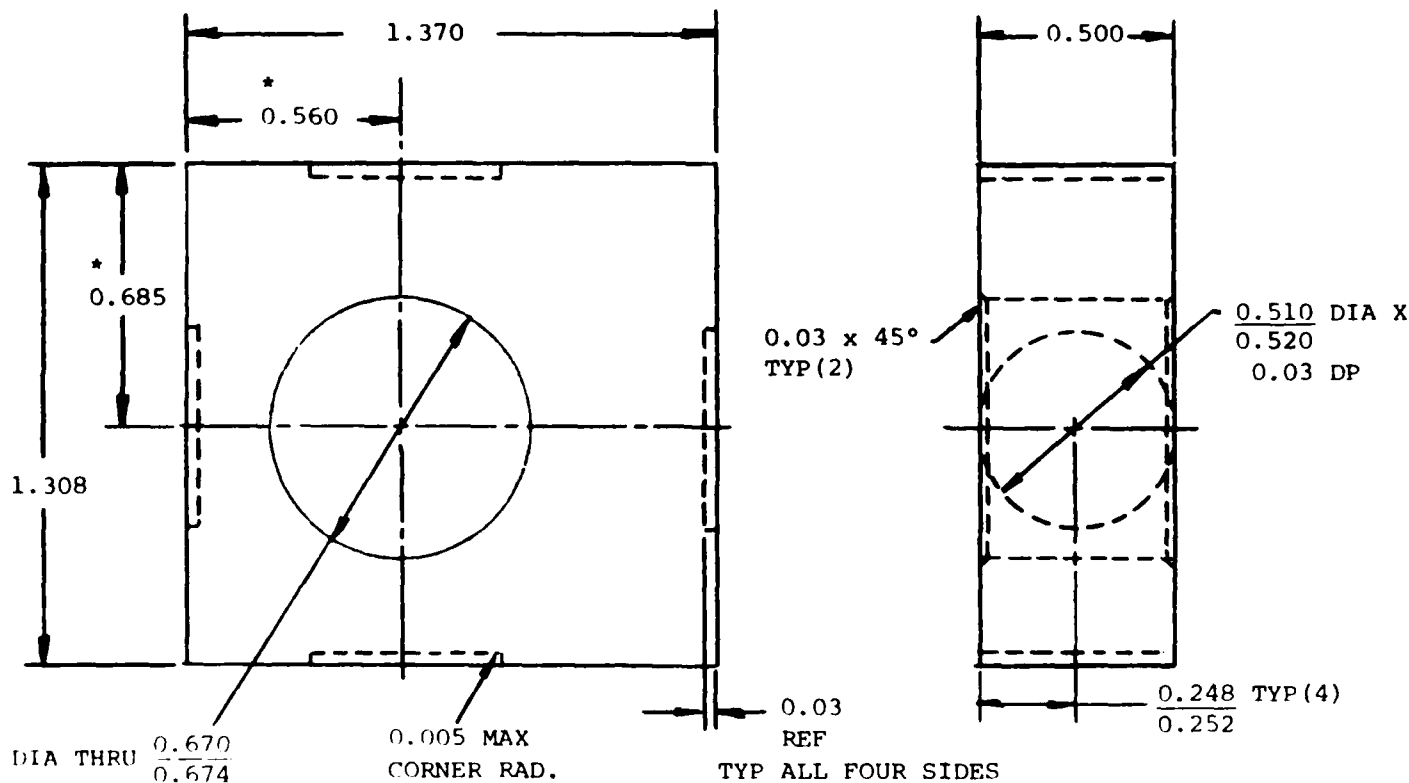

- Notes:
1. Scale 2X
  2. All Dimensions in Inches
  3. Material SST
  4. All sides Parallel to  $\frac{0.670}{0.674}$  Dia Within 0.002.
  5. Surface Finish 63  $\mu$ in all over

Figure 4.7. Test Block (Fixed Spindle).

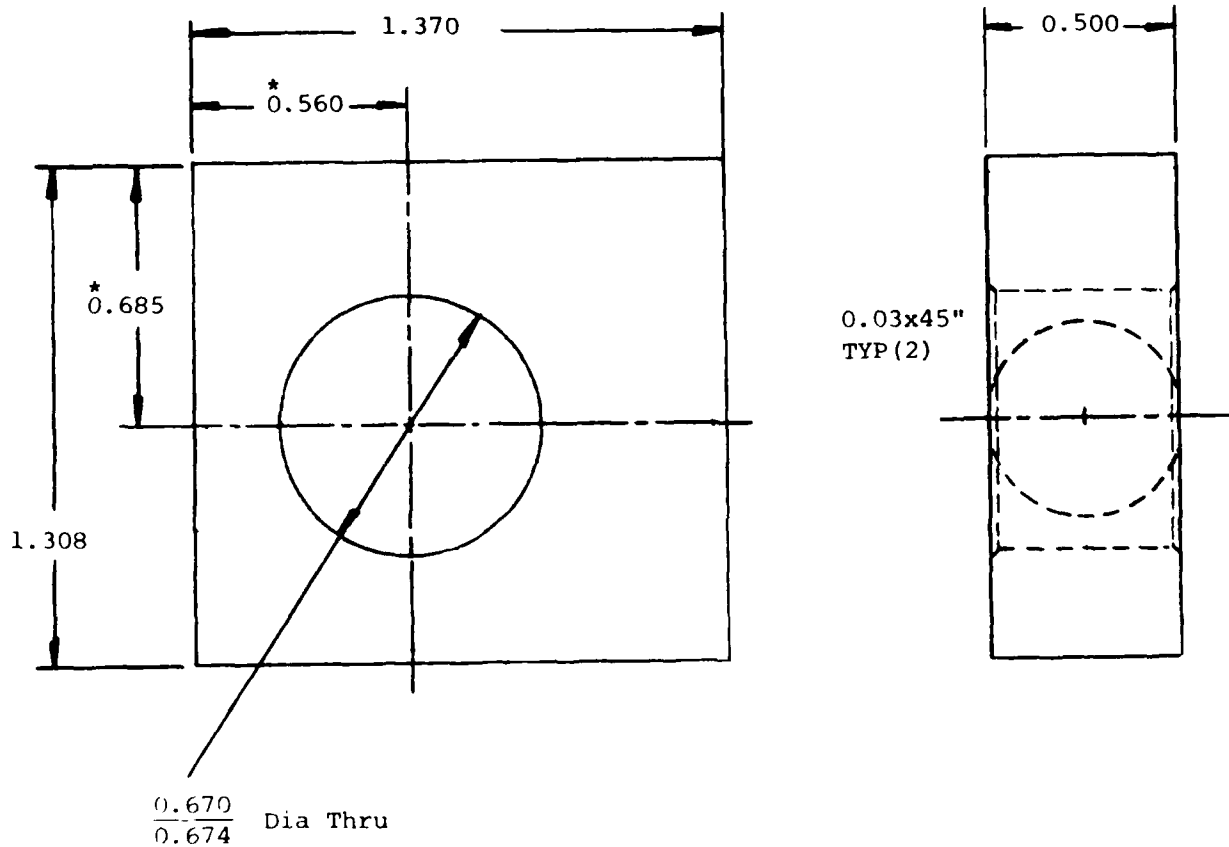

- Notes:
1. Scale 2X
  2. All Dimensions in inches
  3. Material SST
  4. All Sides Parallel to  $\frac{0.670}{0.674}$  Dia Within 0.002
  5. Surface Finish 63  $\mu$ in all over

Figure 4.8. Test Block (Translating Spindle).

# SENSOTEC, INC.

1200 CHESAPEAKE AVENUE, COLUMBUS, OHIO 43212

(614) 486-7723 TWX 810 482 1188

## FORCE TRANSDUCER CALIBRATION RECORD

Type: Compression  Tension \_\_\_\_\_  
Excitation (Input) Volts 5.0 DC  
Model No. 13/1161-17 Compensated Temperature Range:  
Serial No. 56703 60 °F to 160 °F  
Capacity 0-300 LBS  
Date 11-21-80

Capacity:		Output:	
	% of Capacity		Millivolts
Ascending	50%	<u>0</u>	Millivolts
	100%	<u>6.721</u>	Millivolts
Descending	50%	<u>13.460</u>	Millivolts
	0%	<u>6.766</u>	Millivolts
		<u>0</u>	Millivolts

Resistance: Input = 353 Ohms Output = 352 Ohms Leakage = ∞ Ohms  
Connector Type N/A  
Non-Standard \_\_\_\_\_ Standard \_\_\_\_\_  
Input: + A & B  
- C & D  
Output: - E  
+ F

Wiring   
• White = + Output  
• Red = + Input  
• Green = - Output  
• Black = - Input  
Mating Connector N/A  
Shunt Resistor Value of 57K Ohms Across  
Green & Black = 7.453 Millivolts Output  
Signed William A. Lintner

Figure 4.9. Disc Load Cell Calibration.

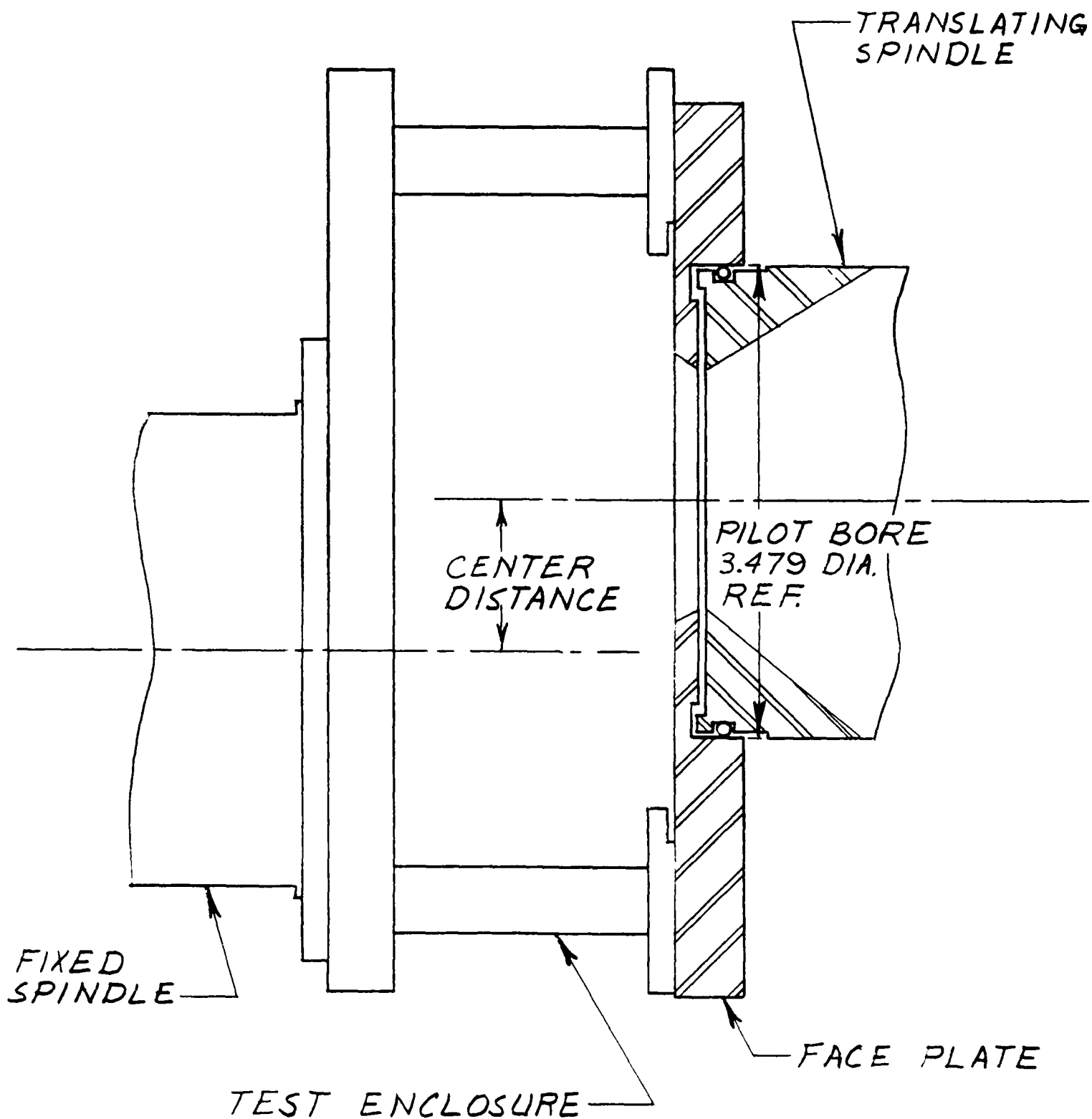
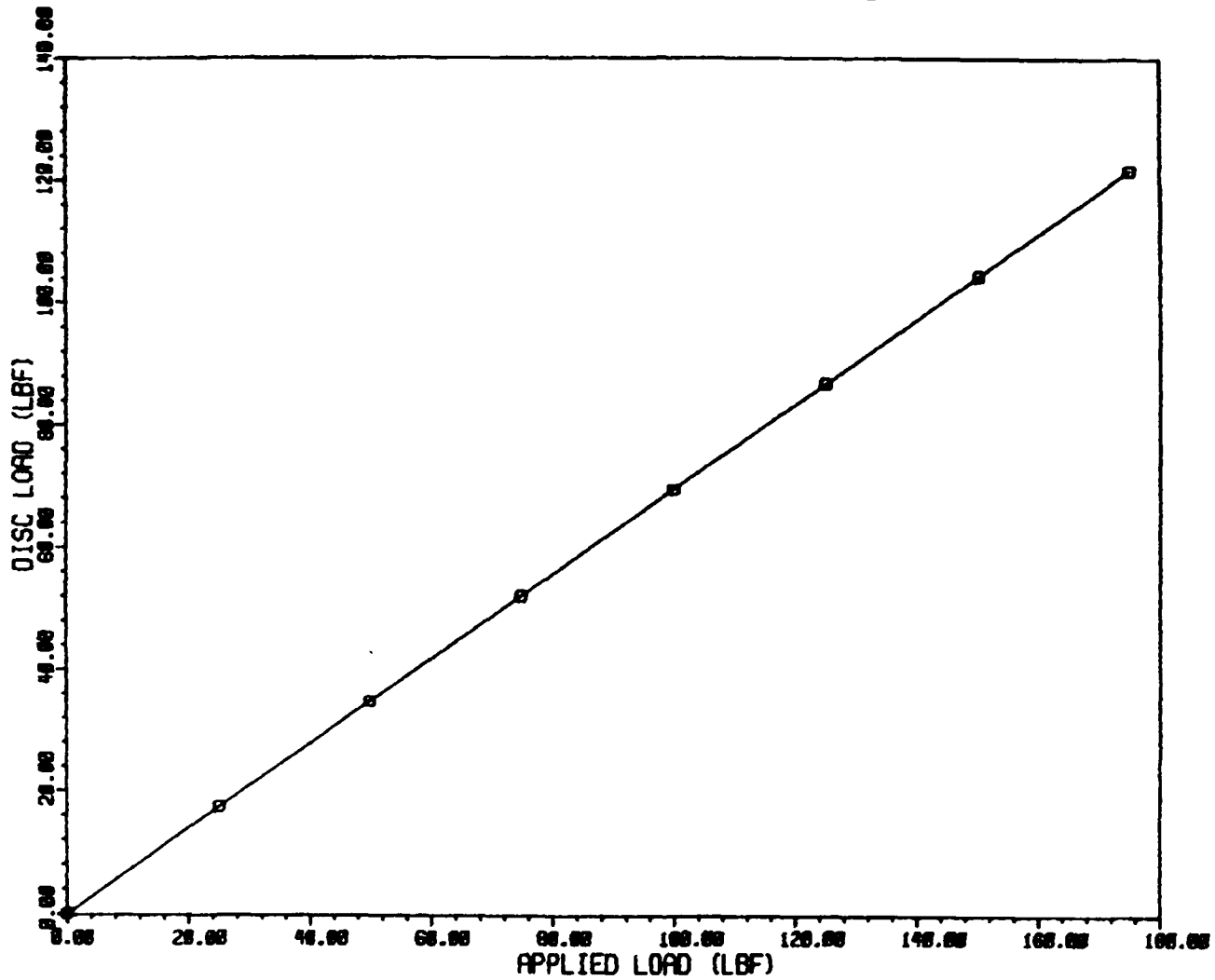

Figure 4.10. Test Enclosure.

# TRACTION RIG DISC LOAD CALIBRATION



- Notes: 1. Gear Coupling and Face Plate Connected.  
2. Rear End of Translating Spindle Restrained With Locking Collar.

Figure 4.11. Calibration Curve, Rear End of Translating Spindle Restrained.

## 5.0 CALIBRATION, REAR END OF TRANSLATING SPINDLE NOT RESTRAINED

This calibration was carried out to provide a correction factor for the disc load for all the tests conducted before April 1984.

We used the procedure described in 4.0 except that rear end of translating spindle was NOT restrained by the use of split locking collar on the rear guide shaft. (Figure 4.1)

A normal load of 6 lbf was applied to the translating spindle through the pneumatic system (Item 61/Figure 2.2). Transmission mount (Item 42/Figure 2.2) was moved to align the gear coupling (Item 15/Figure 2.2) and then locked in place. Another set of data was taken by aligning the gear coupling under 20-lbf normal load.

Lateral movement of translating spindle, at the rear guide bushing, was also recorded to estimate the horizontal misalignment created in the gear coupling because of applied load.

The plots of disc load and the spindle movement are shown in Figure 5.1.

# DISC LOAD CALIBRATION

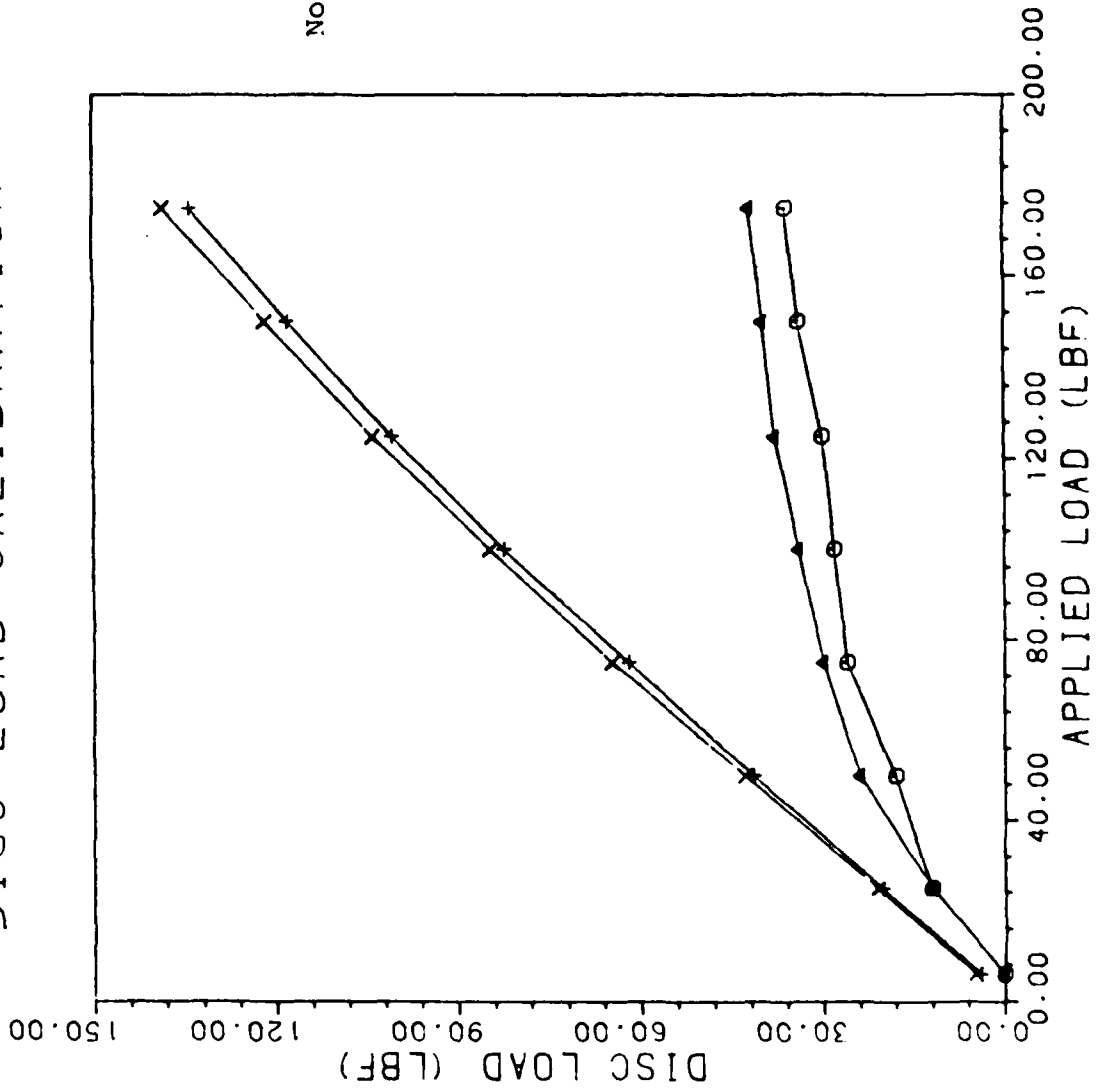

- O DEFL..6 # PRELOAD
- A DEFL..20 # PRELOAD
- + LOAD.20 # PRELOAD
- X LOAD.6 # PRELOAD

Notes: 1. Gear Coupling on Translating Spindle Installed.  
 2. Rear end of Translating Spindle not Restrained With Locking Collar.

Figure 5.1. Calibration Curve, Rear End of Translating Spindle Not Restrained.

END

9-87

Dtic