

AD-A183 789

CONDITION SURVEY OF LOCK NUMBER 8 MONONGAHELA RIVER(U)  
ARMY ENGINEER WATERWAYS EXPERIMENT STATION VICKSBURG MS  
STRUCTURES LAB R L STONE JUN 87 WES/MP/SL-87-4

1/2

UNCLASSIFIED

F/G 13/2

NL

0101



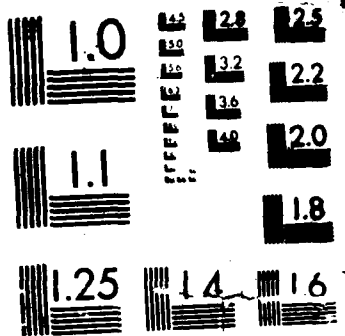

MICROCOPY RESOLUTION TEST CHART

DTIC FILE COPY

2

MISCELLANEOUS PAPER SL-87-4

# CONDITION SURVEY OF LOCK NO. 8, MONONGAHELA RIVER

by

Richard L. Stowe

Structures Laboratory

DEPARTMENT OF THE ARMY  
Waterways Experiment Station, Corps of Engineers  
PO Box 631, Vicksburg, Mississippi 39180-0631

DTIC  
ELECTE  
AUG 21 1987  
S D



June 1987

Final Report

Approved For Public Release Distribution Unlimited

Prepared by US Army Engineer District, Pittsburgh  
Pittsburgh, Pennsylvania 15222-4186

87 8 20 020



US Army Corps  
of Engineers

AD-A183 709

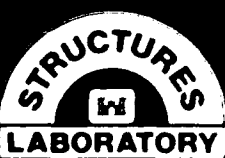

Destroy this report when no longer needed. Do not return  
it to the originator.

The findings in this report are not to be construed as an official  
Department of the Army position unless so designated  
by other authorized documents.

The contents of this report are not to be used for  
advertising, publication, or promotional purposes.  
Citation of trade names does not constitute an  
official endorsement or approval of the use of  
such commercial products.

ADA183709

REPORT DOCUMENTATION PAGE				Form Approved OMB No 0704-0188 Exp Date Jun 30, 1986	
1a REPORT SECURITY CLASSIFICATION Unclassified		1b RESTRICTIVE MARKINGS			
2a SECURITY CLASSIFICATION AUTHORITY		3 DISTRIBUTION/AVAILABILITY OF REPORT Approved for public release; distribution unlimited.			
2b DECLASSIFICATION/DOWNGRADING SCHEDULE					
4 PERFORMING ORGANIZATION REPORT NUMBER(S) Miscellaneous Paper SL-87-4		5 MONITORING ORGANIZATION REPORT NUMBER(S)			
6a NAME OF PERFORMING ORGANIZATION USAEWES Structures Laboratory		6b OFFICE SYMBOL (if applicable) WESSC	7a NAME OF MONITORING ORGANIZATION		
6c. ADDRESS (City, State, and ZIP Code) PO Box 631 Vicksburg, MS 39180-0631		7b ADDRESS (City, State, and ZIP Code)			
8a NAME OF FUNDING/SPONSORING ORGANIZATION USAE District, Pittsburgh		8b OFFICE SYMBOL (if applicable) ORPED	9 PROCUREMENT INSTRUMENT IDENTIFICATION NUMBER		
8c. ADDRESS (City, State, and ZIP Code) Pittsburgh, PA 15222-4186		10 SOURCE OF FUNDING NUMBERS See reverse			
		PROGRAM ELEMENT NO	PROJECT NO	TASK NO	WORK UNIT ACCESSION NO
11 TITLE (Include Security Classification) Condition Survey of Lock No. 8, Monongahela River					
12 PERSONAL AUTHOR(S) Stowe, Richard L.					
13a TYPE OF REPORT Final report		13b TIME COVERED FROM _____ TO _____	14 DATE OF REPORT (Year, Month, Day) June 1987		15 PAGE COUNT 153
16 SUPPLEMENTARY NOTATION Available from National Technical Information Service, 5285 Port Royal Road, Springfield, VA 22161.					
17 COSATI CODES		18 SUBJECT TERMS (Continue on reverse if necessary and identify by block number)			
FIELD	GROUP	SUB-GROUP			
			Concrete condition survey Lock and dam		
			Concrete deterioration Monongahela River		
			Dam inspection		
19 ABSTRACT (Continue on reverse if necessary and identify by block number) A condition survey was performed at Lock and Dam No. 8 on the Monongahela River in Pennsylvania to determine the quality of concrete, extent of possible concrete damage, processes causing distress of the concrete, and selected physical and mechanical properties of the concrete and foundation materials. The field investigation included a visual examination of the lock and drilling operations to recover concrete and foundation core. Results of the field investigation and laboratory tests indicated that the processes causing distress in the concrete are freezing and thawing action and alkali-silica reaction. The concrete is extensively damaged on and near the top of the guide, guard, and lock walls. Overall the lock concrete is in poor condition evidenced by fine to wide cracking, light to severe scaling, and large spalls. Low-quality concrete exists to depths of 3 ft vertically and 3 ft horizontally in the guide, guard, and lock walls. Concrete beneath the damaged zones is considered to be of good quality.					
(Continued)					
20 DISTRIBUTION AVAILABILITY OF ABSTRACT <input checked="" type="checkbox"/> UNCLASSIFIED/UNLIMITED <input type="checkbox"/> SAME AS RPT <input type="checkbox"/> DTIC USERS			21 ABSTRACT SECURITY CLASSIFICATION Unclassified		
22a NAME OF RESPONSIBLE INDIVIDUAL			22b TELEPHONE (include Area Code)		22c OFFICE SYMBOL

Unclassified

SECURITY CLASSIFICATION OF THIS PAGE

10. SOURCE OF FUNDING NUMBERS (CONTINUED).

DA Form 2544, No. ORPED-82-69, dated 12 August 1982.

19. ABSTRACT (CONTINUED).

Cores recovered from the two upstream gate recess monoliths contain rubble and broken (first-size) and cracked concrete. Damaged concrete in the landwall upper gate recess exists at least 3 ft from the sector pin assembly.

Unclassified

SECURITY CLASSIFICATION OF THIS PAGE

PREFACE

The work described in this report was performed for the US Army Engineer District, Pittsburgh, by personnel of the US Army Engineer Waterways Experiment Station (WES). The work was authorized by DA Form 2544, No. ORPED-82-69, dated 12 August 1982.

The testing program was accomplished under the direction of Mr. Bryant Mather, Chief, Structures Laboratory (SL), WES, and Mr. John M. Scanlon, Jr., Chief, Concrete Technology Division (CTD), SL. The majority of the core drilling was conducted by the US Army Engineer District, Mobile, under the direction of Mr. Pat Douglas. Some horizontal drilling was conducted by a private drilling company from Pittsburgh and was under the direction of Mr. Frank Pehr, Geotechnical Branch, Pittsburgh District. Laboratory work in the CTD was done with the assistance of Mr. F. S. Stewart, Mrs. Joyce C. Ahlvin, and Mr. G. Sam Wong. Mr. Richard L. Stowe was Project Leader for the investigation. Mr. Stowe prepared this report.

COL Allen F. Grum, USA, was the previous Director of WES. COL Dwayne G. Lee, CE, is the present Commander and Director. Dr. Robert W. Whalin is Technical Director.



CLASSIFICATION	
IS SECRET	<input checked="" type="checkbox"/>
IS UNCLASSIFIED	<input type="checkbox"/>
EXEMPT FROM AUTOMATIC DOWNGRADING AND DECLASSIFICATION	<input type="checkbox"/>

APPROVED FOR RELEASE BY  
[Signature]

## CONTENTS

	<u>Page</u>
PREFACE . . . . .	1
CONVERSION FACTORS, NON-SI TO SI (METRIC) UNITS OF MEASUREMENT . . . . .	3
PART I: INTRODUCTION . . . . .	4
Project Description . . . . .	4
Background . . . . .	4
Objectives . . . . .	5
Scope . . . . .	5
PART II: PRELIMINARY STUDY . . . . .	6
PART III: DRILLING OPERATION . . . . .	13
PART IV: GEOLOGY . . . . .	18
PART V: TEST SPECIMENS AND TEST PROCEDURES . . . . .	20
Cores Received . . . . .	20
Selection of Test Specimens . . . . .	20
Laboratory Test Program . . . . .	20
Test Procedures . . . . .	22
PART VI: TEST RESULTS AND DISCUSSION . . . . .	25
Petrographic Examination . . . . .	25
Reinforcing Bar Pullout Resistance . . . . .	26
Peak and Residual Shear Strength . . . . .	27
Concrete Quality . . . . .	31
PART VII: CONCLUSIONS, SUMMARY, AND RECOMMENDATIONS . . . . .	38
Conclusions and Summary . . . . .	38
Recommendations . . . . .	40
REFERENCES . . . . .	41
TABLES 1-5	
PLATES 1-82	
APPENDIX A: PHOTOGRAPHS OF LOCK NO. 8, MONONGAHELA RIVER . . .	A1
APPENDIX B: FIELD DRILLING LOGS, LOCK NO. 8, MONONGAHELA RIVER . . . . .	B1
APPENDIX C: CONCRETE PETROGRAPHIC REPORT, LOCK NO. 8, MONONGAHELA RIVER . . . . .	C1
EXHIBIT A: PHOTOGRAPHS OF DRILLED CORE*	
EXHIBIT B: DETAILED DRILLING LOGS*	

---

\* On file in the Pittsburgh District.

CONVERSION FACTORS, NON-SI TO SI (METRIC)  
UNITS OF MEASUREMENT

Non-SI units of measurements used in this report can be converted to SI (metric) units as follows:

Multiply	By	To Obtain
feet	0.3048	metres
inches	25.4	millimetres
microns	1	micrometres
pounds (force)	4.448222	newtons
pounds (force) per foot	14.59390	newtons per metre
pounds (force) per square inch	0.006894757	megapascals
pounds (mass) per cubic foot	16.018463	kilograms per cubic metre
tons (force) per square foot	95.76052	kilopascals

## CONDITION SURVEY OF LOCK NO. 8

### MONONGAHELA RIVER

#### PART I: INTRODUCTION

##### Project Description

1. The following general description is taken from the third periodic inspection report of Lock and Dam No. 8 (U. S. Army Engineer District, Pittsburgh 1979).

Lock and Dam 8 is located on the Monongahela River, 90.8 miles above the mouth of the river at Pittsburgh, Pa. The pool extends 11.2 miles upstream to Morgantown Lock and Dam. The project was constructed in 1923-1926. The lock is located on the left bank and consists of a single, 56 foot by 360 foot chamber with a normal lift of 19.0 feet. The lock walls and gate sills are unreinforced concrete gravity sections founded on bedrock. Top of wall elevation is 803.0.\* The dam piers are reinforced concrete construction and are founded on bedrock. The dam consists of six bays with non-overflow movable trunnion gates, 70 feet long by 8.5 feet high, and a 65 foot long fixed weir with crest elevation 795.7, for a total length of 560 feet. The standard project flood is a flow of 137,000 cfs resulting in an upper pool elevation of 809.5 and lower pool elevation of 807.0. The maximum flow of record was 85,000 cfs with upper pool at 804.4 and lower pool at 802.5 on 7 March 1967.

A general plan view of the project site is presented in Plate 1; this plate is taken from the first periodic inspection report (U. S. Army Engineer District, Pittsburgh 1972).

##### Background

2. In August of 1982, the Waterways Experiment Station (WES) was requested by the U. S. Army Engineer District, Pittsburgh (ORP for Ohio River Division, Pittsburgh), to submit a proposal for a condition survey

---

\*All elevations (el) cited herein are in feet referred to mean sea level

of Locks 7 and 8 on the Monongahela River (Mon River). Engineering information and data were supplied by the District for review (see Table 1). The materials included contract, design, construction, and operational documents, foundation and geological reports, project photographs, and material property test reports. The information and data were used in working up the WES proposal and was used throughout our work. The foundation drilling program and the majority of the testing program were established by the District.

### Objectives

3. The objectives of the condition survey are: (a) identify the processes or materials causing distress or failure of the concrete and the probable extent of such damage, (b) determine the ability of the concrete to perform satisfactorily under anticipated conditions of future service, and (c) determine selected physical and mechanical properties of the foundation rock for verification of previous testing. The Pittsburgh District is scheduled to perform structural stability analyses.

### Scope

4. This report presents the findings of an inspection of the project prior to drilling. The drilling effort involved in recovering samples of concrete and foundation rock is discussed. The physical condition and extent of damage of in-place concrete are described using visual, petrographic, and physical property information and data. Selected physical properties of core samples were determined using standard Corps of Engineers test methods. The ability of the concrete to perform its original intended function is also discussed.

## PART II: PRELIMINARY STUDY

5. The author and Mr. Frank Pehr of the District office made an inspection of Lock No. 8. The main purpose was to ascertain the general condition of the lock, guide, and guard walls, and determine the location of borings for obtaining concrete and foundation cores. Observed concrete deficiencies are discussed in the following paragraphs. These observations agree with those observations made by others as presented in the periodic inspection reports (U. S. Army Engineer District, Pittsburgh 1972 and 1979). The top surface of the lock, guide, and guard walls are believed to be resurfaced in 1942. The condition of the concrete below this resurfaced portion will have to be evaluated with core borings.

### Upper Guide Wall

6. The vertical face at the upstream end of the upper guide wall is lightly eroded; it contains small spalls, a few longitudinal and transverse cracks (both wide\*), and local vertical small joint spalls; the top surface has a few spalls and longitudinal and transverse cracks. In general, the concrete appears to be in fair condition for this segment of the wall.

7. The top surface of the upper guide wall concrete appears to be in good condition. There are a few small areas of light to medium scaling, a few small and large spalls, a few longitudinal cracks (wide) upwards of 50 ft long, and transverse cracks (fine to wide) averaging one every 9 ft for the upper two-thirds of the wall. The transverse cracks are less frequent for the last one-third of the wall averaging one every 12 ft.

8. The vertical face of the wall concrete is in poor condition; it is badly gouged, contains small to large spalls and severe to very

---

\* Crack widths: fine - generally less than 1 mm; medium - between 1 and 2 mm; wide - over 2 mm. See American Concrete Institute 1980 for definitions of terms associated with the durability of concrete.

severe scaled areas. A few longitudinal cracks (wide) are present with efflorescence deposited on and below the cracks. Joint spalls are also present.

9. New concrete and mortar patches on the top of the wall are in generally good condition; however some are drummy. Appendix A presents typical photographs (1 through 5) of the upper guide wall surfaces.

#### Lower Guide Wall

10. The top surface of the lower guide wall concrete appears to be in good condition. There are very few small areas of light to medium scaling and an occasional small spall. A few longitudinal and transverse cracks (fine to wide) were observed.

11. Shotcrete was applied to the lock walls and upper and lower guide walls in 1956. The back side of the wall is mostly covered with shotcrete which for the most part is drummy; the wall contains vertical and horizontal cracks, a few small to medium popouts, and vertical joint spalls. The shelf is original concrete and is in very poor condition with large spalls and drummy areas.

12. About 40 percent of the vertical face of the wall concrete (chamber side) is in very poor condition. The remainder of the face is in fair to poor condition. Shotcrete has failed and come off from over about 40 percent of the wall surface with wire mesh being exposed in places. The concrete is very severely scaled, has large spalls, eroded, and deeply gouged. Vertical construction joints have spalls from at least low pool elevation and upward with the largest spalls occurring just above low pool elevation. Maximum spalls are estimated to be about 12 in. deep. Some joints have diagonal cracking present; these occur near the top of the wall. Appendix A presents typical photographs (6 through 9) of the lower guide wall surfaces.

### Upper Guard Wall

13. The top surface of the upper guard wall concrete appears to be in good condition. There are a few small and large spalls, small areas of light scaling, and an occasional transverse crack (wide).

14. The vertical face of the wall concrete is in poor condition; small areas of medium scaling and spalling and horizontal cracks (wide) are present. Small joint spalls are present on all exposed vertical construction joints.

### Lower Guard Wall

15. The top surface of the wall concrete is in fair to good condition. There are a few large spall areas, a few transverse cracks (wide), and several medium size areas (approximately 40 sq ft) of random cracking. The surface has a number of concrete/mortar patches that are in good condition.

16. About 60 percent of the vertical face of the wall concrete (chamber side) is in very poor condition; the remainder of the face is in poor condition. The shotcrete is missing from about 60 percent of the face; wire mesh is exposed in places. The concrete is very severely scaled, is spalled over about 60 percent of its face, eroded deeply and gouged near the waterline. The in-place shotcrete has numerous horizontal and random cracks (wide) with efflorescence deposited on and below some cracks; much of the shotcrete appears dummy. The vertical construction joints are spalled from at least low pool elevation and upward with larger spalls occurring near low pool elevation. Estimated maximum depth of spalls is 8 to 10 in.

17. Appendix A presents typical photographs (9 through 12) of the lower guard wall surfaces.

### Land Lock Wall

18. The top surface of the land lock wall concrete appears to be in fair to good condition. There are a few local areas of light scaling and small spalling. Several short (<25 ft) longitudinal (wide) and about 15 transverse (medium to wide) cracks were observed on the top surface of the wall. Most of the cracks are filled with a sealer or debris. The armor plate-resurfaced concrete contact is in good condition.

19. The vertical face of the land lock wall concrete is in very poor condition. About 25 percent of the concrete above upper pool elevation is scaled (medium) and has small spalls. Below this mark and down to low pool elevation, the concrete is about 70 percent severely scaled and spalled and is deeply eroded and gouged. An estimated 70 percent of the shotcrete has failed and come off with considerable wire mesh exposed. The shotcrete protrudes from the wall such that boats and barges could easily catch on these overhangs. Serious damage could occur if pieces of shotcrete were dislodged in this manner. All vertical construction joints have spalled from at least beginning at low pool elevation and upward. Estimated maximum depth of the joint spalls is 9 in.

20. Appendix A presents typical photographs (13 through 15) of the land lock wall surface.

### River Lock Wall

21. There is a slight inward bow of the river lock wall; see Photo 17 in Appendix A. This misalignment is documented in the first periodic inspection report (U. S. Army Engineer District, Pittsburgh 1972). Precise alignment and settlement data recorded in 1980 and 1981 show some river wall monoliths moving slightly (maximum 0.1 in.) landward and to a lesser amount riverward. These data are presented in a District drawing entitled "Lock and Dam 8, Monongahela River, River Wall, Precise Alignment and Settlement," dated 20 May 1981; the drawing was furnished to WES by the District (see Table 1).

22. The top surface of the river lock wall concrete appears to be in fair to good condition. There are a few small and large spalls and several small areas of light scaling and several large areas of medium scaling. A few transverse cracks (fine) and local areas of D-cracking are present. Construction joint spalls (small) are present.

23. The vertical face of the river lock wall concrete in the chamber side is in very poor condition. The same concrete deficiencies that are present in the land lock wall are present in the river lock wall; these deficiencies have a greater degree of deterioration in the river wall. For example, the maximum depth of vertical construction joints is about 12 in. instead of 9 in. in the land lock wall.

24. Appendix A presents typical photographs (16 through 21) of the river lock wall surfaces.

#### Miter Gate Recesses

25. Surface concrete in all four miter gate recesses is in very poor condition. This condition exists in the recess vertical faces and on horizontal surfaces beneath the gate operating machinery assemblies, in particular the sectors. The concrete areas just below and adjacent to the sector and sector arm, when the gates are closed, are badly spalled (large) and scaled (very severe); cracking is also present (see Figure 1).

#### Concrete Condition Below Waterline

26. Little information is available in the literature received at the WLS concerning the condition of the concrete below the waterline. Information from a diver's report indicates that the concrete in the upper and lower guide and guard walls is in good condition (U. S. Army Engineer District, Pittsburgh 1979). The upper and lower miter sills are also reported to be in good condition.

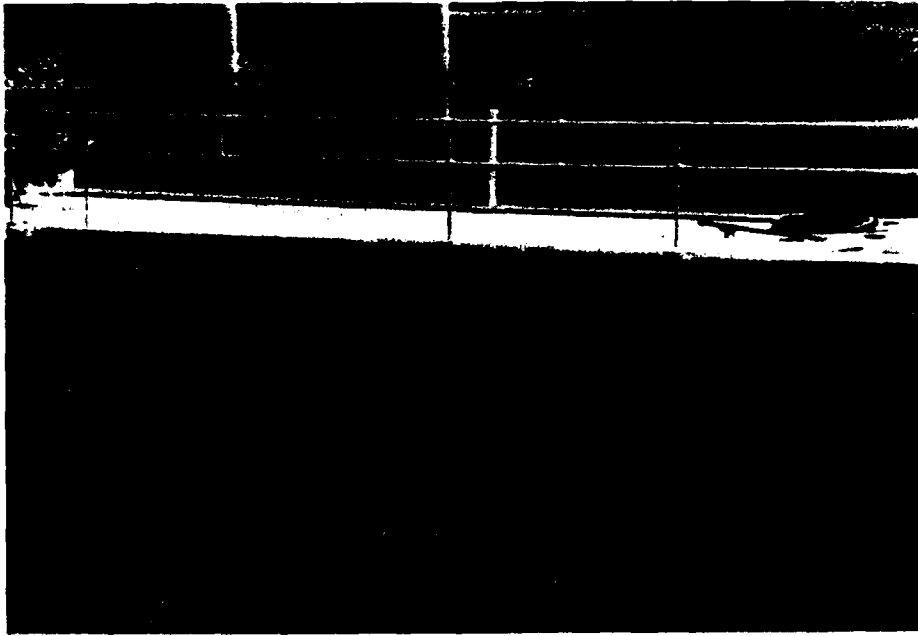

a. Upper miter gate recess river wall showing extensive spalling and scaling; horizontal and vertical cracks (wide) also present



b. Corner top surface of wall above upper miter gate recess river wall showing very severe scaling; transverse cracks (wide) are present

Figure 1. Concrete surface damage in the miter gate recess

(Continued)

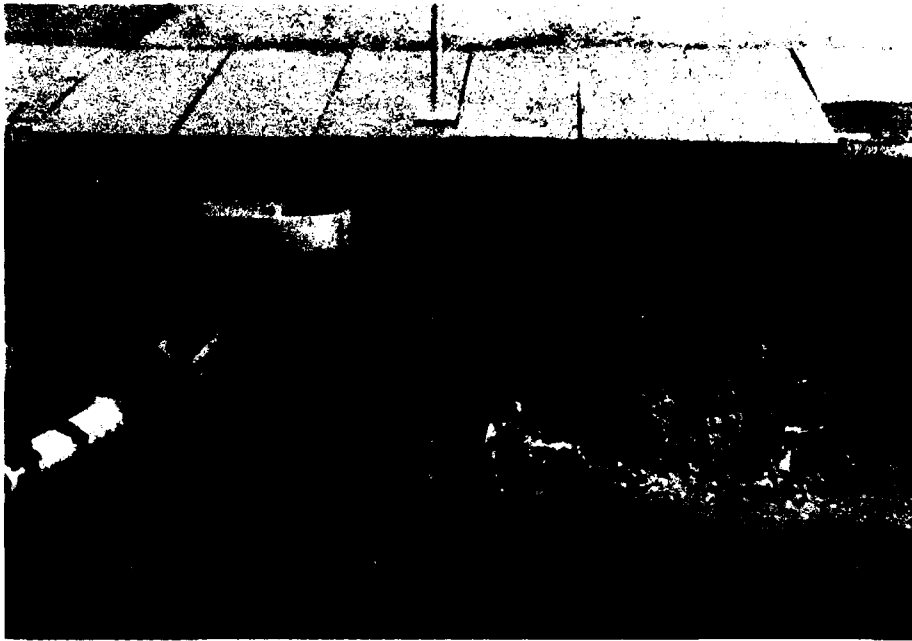

c. Lower miter gate recess land wall showing extensive spalling and very severe scaling



d. Lower miter gate recess river wall showing spalling and horizontal and D-cracking

Figure 1 (Concluded)

### PART III: DRILLING OPERATION

27. At the completion of the inspection of the lock, boring locations were assigned in areas that were representative of the various degrees of deteriorated concrete; see Plate 2 for boring locations. Guidance was given by District personnel on the total number of borings. This guidance was partially based upon the time remaining before the severe winter weather set in. Pertinent boring information concerning the boring number, the monolith number the boring was placed in, depth, core size, boring direction, elevation top of boring, elevation top of rock, and elevation bottom of boring is presented in Table 2.

28. Total footage drilled was 312.7 ft of concrete and 92.3 ft of foundation rock; total number borings drilled was 27. The bedrock core was preserved for possible laboratory testing, the exception being the highly fractured pieces. Procedures for preserving and handling the bedrock are given in Test Standard RTH 103-80 (U. S. Army Engineer Waterways Experiment Station 1980). Color photographs of the core are presented in Exhibit A.

29. Core recovery was good in all borings; the average core recovery was 99 percent. The majority of the core loss occurred in borings PM-WES L-1-82\* near the concrete bedrock contact. The general condition of the concrete and foundation core is illustrated in Figures 2 and 3. Figure 4 shows typical concrete overlay with badly broken concrete beneath.

30. Drilling equipment consisted of a Failing 43-5A skid rig and a portable electric drill for taking horizontal core. A Diamond Core Drill Manufacturers Association standard 6-in. by 7-3/4-in. and 4-in. by 5-1/2-in. double tube swivel tube core barrel was used with diamond bits to obtain the concrete and bedrock core in the vertical borings. A single tube core barrel with a diamond bit was used to take the horizontal core. Access to the drill holes on top of the lock walls was by crane

---

\* PM = Point Marion; WES = drilling agency, Waterways Experiment Station; L = lock; number after L indicates number of boring; and 82 is year boring was made (1982).

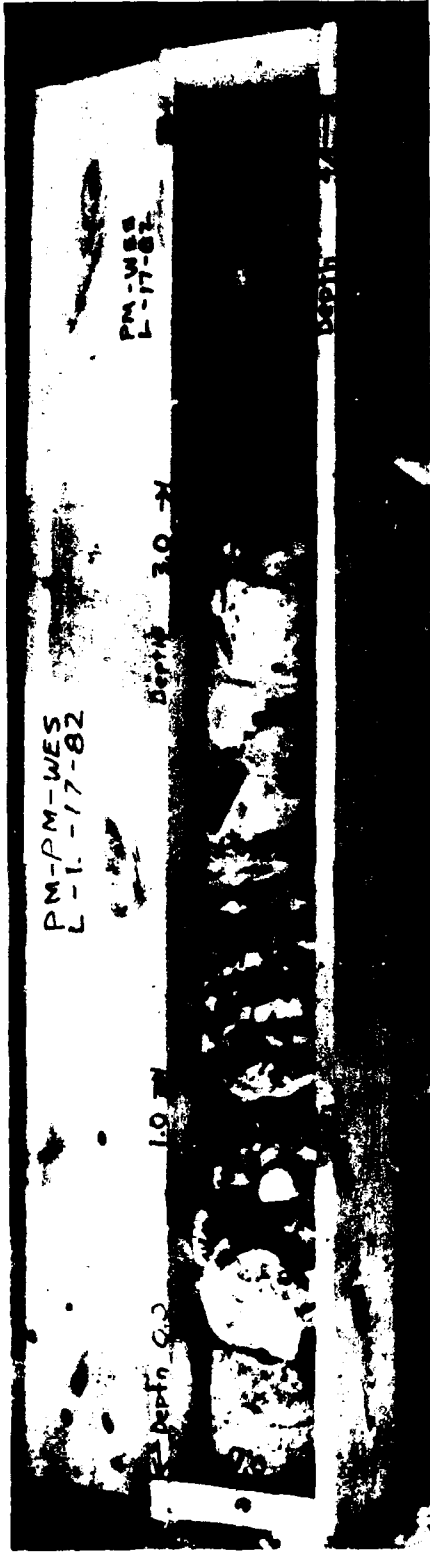

Shotcrete Rubble w/wht subparallel 1.6 ft  
 overlay reaction product cracking

a. Typical vertical concrete core, river lock wall



b. Typical horizontal concrete core, lower guide wall

Figure 2. Typical condition of concrete and foundation core

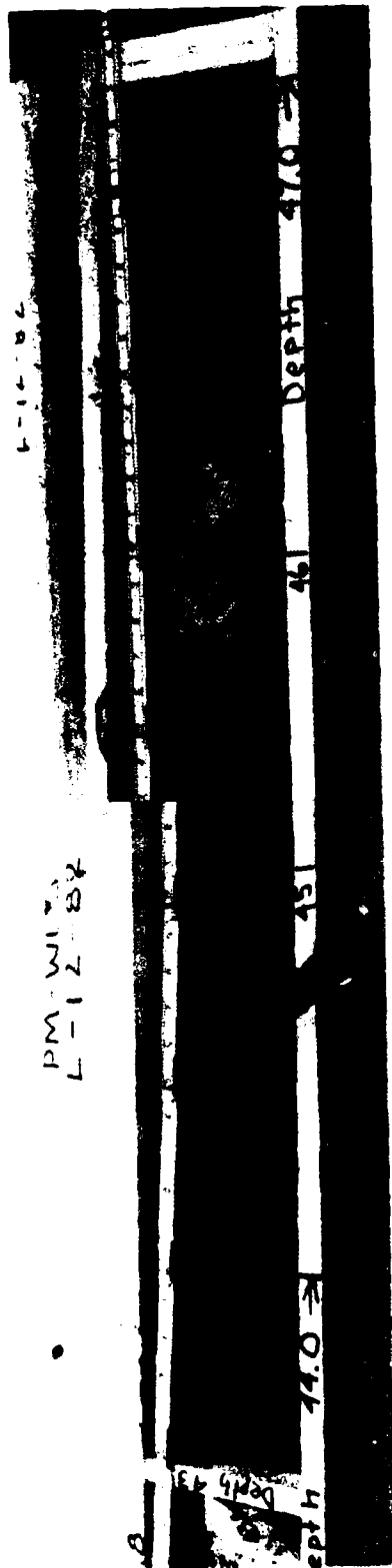

Concrete/rock  
contact

Indurated clay

a. Rock from just below river wall, broken during drilling

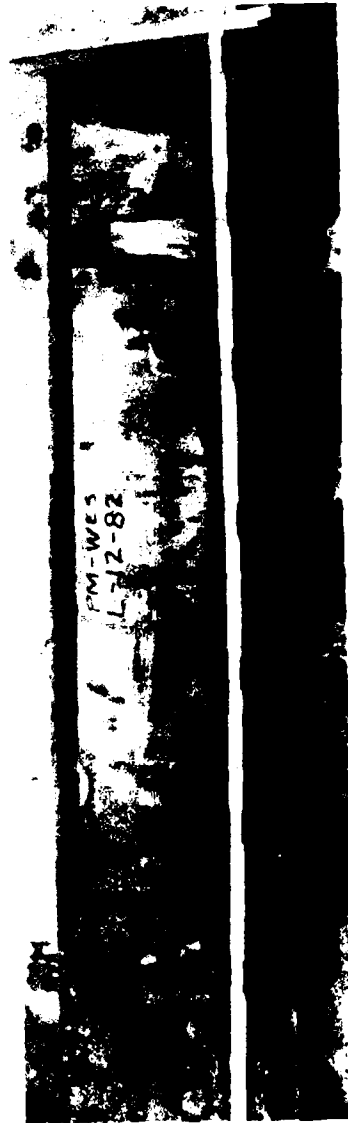

b. Rock about 15 ft below concrete/rock contact

Figure 3. Typical condition of foundation rock



a. New overlay; note broken concrete beneath overlay and crack between the two concretes



b. End view of core recovered from boring in Figure 4a; note white reaction product on aggregates. Depth 0.0 to 0.45 ft

Figure 4. Overlay with badly broken concrete beneath, boring PM-WES-I-7-82 upper guide wall

and by a cable hoist. Access to the horizontal boring locations was by a marine work platform supplied by the lockmaster.

31. Personnel from the U. S. Army Engineer District, Mobile, drilled the vertical borings and about one-third of the horizontal borings. The Pittsburgh District contracted with the Pitt Industrial Diamond Products, Inc. to drill the remaining horizontal borings at Lock 8 and all but one of the horizontal borings at Lock 7. This was done to expedite the drilling operation.

## PART IV: GEOLOGY

32. The description of the site geology is taken from the first periodic inspection report (U.S. Army Engineer District, Pittsburgh 1972).

The Monongahela River in the vicinity of Point Marion, Pennsylvania, and Lock and Dam 8 flows in a series of entrenched meanders through the maturely dissected Kanawha section of the Appalachian Plateaus province in a valley carved in the Allegheny, Conemaugh and Monongahela formations of the Pennsylvanian system. Regional relief varies from a minimum elevation of approximately 764 feet in the bed of the Monongahela River to a maximum elevation of 1477 feet in the uplands. The valley width is approximately 1300 feet with the river comprising 700 feet and flood plain and valley fill deposits at 600 feet.

The rocks of the region consist of flat lying, cyclic sediments, chiefly indurated clays, siltstones, sandstones and coal, all of which are members of the middle Conemaugh formation. The major geologic structure in the general vicinity is the Fayette anticline which runs parallel to the land wall.

The overburden at the site is composed mainly of alluvial soils in the river bottom ranging from 6 to 29 feet in thickness, with alluvial deposits comprising the flood plain deposits on the lock side and coluvial (sic) deposits comprising the abutment side. The alluvial materials consist of silty sandy gravels or clayey sandy gravels ranging from brown to gray in color. The coluvial (sic) material consists of silty clays and clayey silts reddish gray in color with numerous rock fragments.

33. District personnel are scheduled to revise existing foundation exploration profiles using the geologic information contained in the WES detailed drilling logs. Boring logs PM WES L-1-82, L-10-82, and L-12-82 contain such information; see Appendix B. Because of the scheduled revision, no geologic profile sheets were prepared during this condition survey.

34. The lithologic units identified in the WES borings (L-1-82, L-10-82, and L-12-82) and those contained in drilling logs L-1 037-L8-10/1 and D-7 037 L-8-10/1 from the Pittsburgh District's project "Raise Crest of Dam No. 8, Mon River" correlate quite well. No significant lithologic differences exist nor are any structural feature differences

apparent in the two sets of logs. The concrete-rock contact in the core is loose in L-1-82 and L-10-82 and tight in L-12-82.

35. The unit directly beneath the concrete is a soft, gray, indurated clay with thin moderately hard layers and is weathered and breaks easily. Calcareous nodules are scattered throughout the hard, brown unit and average about 1 in. in size. Average thickness beneath the concrete is 7.7 ft. Borings L-1-82, L-10-82, and L-12-82 yielded about 40, 42, and 61 percent broken core, respectively, from this unit. Broken core means that pieces ranged in size from a fraction of an inch to 6 in. (see Figure 3a). The majority of broken core is suspected to have been caused by rough drilling action or by the use of inappropriate drilling equipment.

36. Underlying the soft indurated clay is the first of two moderately hard, gray siltstone units; this unit contains a number of high angle joints in L-12-82 inclined from 40 to 60 degrees. Average thickness is 3.0 ft.

37. Underlying the siltstone is a moderately hard, medium gray to gray indurated clay; there are several layers of soft and soft to moderately hard indurated clay contained in the unit. Hard, brown calcareous nodules from 1/2 to 2 in. in diameter are present throughout the unit. A few low angle high angle joints ( $10^{\circ}$  to near vertical) are scattered throughout the core. Average thickness is 16 ft.

38. The next unit in the section is a hard, black coal seam (the Bakerstown seam); it is somewhat blocky and contains small pyrite nodules. Average thickness is 2.6 ft.

39. Underlying the coal is a soft to moderately hard, gray indurated clay; hard, brown calcareous nodules are scattered throughout. Average thickness is 4 ft. The unit is slightly weathered in boring L-12-82.

40. Beneath the soft to moderately hard indurated clay is a hard, gray siltstone unit that is slightly clayey; hard, brown calcareous nodules are scattered throughout the rock. The rock is hard, dense, and sound. Average depth drilled into the rock is 9 ft.

## PART V: TEST SPECIMENS AND TEST PROCEDURES

41. Field procedures for preparing the foundation rock for testing were as follows. After removal from the core barrel, the core was marked to indicate boring location and depth. Photographs were taken and a quick drilling log prepared. Moistureproofing was accomplished by waxing the core. The core was wrapped in thin polyethylene (Saran Wrap), wrapped with cheese cloth, and then coated with a lukewarm wax mixture to an approximate 1/4-in. thickness. The wax consisted of a 1 to 1 mixture of paraffin and microcrystalline wax. The core was placed in a wooden core box and cushioned with sawdust. RTH 103-80 was used as guidance (U. S. Army Engineer Waterways Experiment Station 1980).

### Cores Received

42. Concrete and foundation rock samples from the 27 borings were shipped by Government motor freight. All samples were received in good condition; no sample breakage was detected. Pertinent core information is presented in Table 3.

### Selection of Test Specimens

43. A detailed visual examination of all core was made in the laboratory to supplement the field boring logs and to assist in the selection of representative test specimens. Concrete specimens were selected for testing based upon physical condition of the concrete and depth in order to obtain representative properties through the structure. In the three vertical borings through the lock walls specimens were taken from the top, middle, and bottom of the core.

44. An attempt was made to select test specimens to be representative of the bedrock in close proximity to the base of the structure. The test assignment locations can be obtained from appropriate tables of test results. Due to the breakage of the indurated clay during drilling, test specimens of the rock were limited. It is believed that an adequate number of specimens of this rock were tested. Test specimens were selected for testing concurrent with the detailed logging of core; the logging began one week after the core arrived at the laboratory. The test specimens were rewrapped and stored in a moist curing room until time for testing; the moist room is maintained at  $73.4 \pm 3$  F ( $23 \pm 1.7$  C).

#### Laboratory Test Program

##### Concrete Cores

45. The testing program of the concrete cores consisted of the following tests and examination.

- a. Petrographic examination.
- b. Unit weight,  $\gamma$ .
- c. Compression wave velocity,  $V_p$ .
- d. Compressive strength.
- e. Elastic modulus,  $E$ .
- f. Poisson's ratio,  $\nu$ .

##### Rock Cores

46. The testing of the bedrock cores consisted of the following tests. The tests are grouped under either characterization tests or engineering design tests.

- a. Characterization tests.
  - (1) Effective (as-received) unit weight,  $\gamma_m$ .
  - (2) Water content,  $w$ .
  - (3) Compressive strength,  $q_u$ .

b. Engineering design tests.

Direct shear strength.

- (a) Concrete on rock, precut (residual).
- (b) Intact (peak and residual).
- (c) Concrete bonded to rock (peak and residual).

Test Procedures

47. The characterization properties tests and the engineering design properties tests were conducted in accordance with the appropriate test method tabulated below:

Property	Test Method	
	Rock	Concrete
<u>Characterization</u>		
Effective Unit Weight (As-Received), $\gamma_m$	RTM 109-80	CRD-C23-84
Water Content, $w$	RTM 106-80	RTM-106-80
Compressional Wave Velocity, $V_p$	RTM 110-80	CRD-C51-70
Compressive Strength, $q_u$	RTM 111-80	CRD-C14-85
<u>Engineering Design</u>		
Elastic Modulus, $E$	RTM 201-80	CRD-C19-83
Poisson's Ratio, $\nu$	RTM 201-80	CRD-C19-83
Direct Shear Strength	RTM 203-80	--
<u>Petrographic Examination</u>	RTH 109-80*	CRD-C57-78

\* The test procedures used in conducting the petrographic examination are described in Appendix C.

48. For the compression test, the specimens were cut with a diamond-blade saw and the cut surfaces were ground flat to 0.001 in.; specimens were checked for planeness, parallel ends, and the perpendicularity of ends to the axis of the specimen. Electrical resistance strain-gages and Linear variable differential transducers were used for strain measurements. The modulus of elasticity and Poisson's ratio were computed from the strain measurements. Axial specimen load was applied using a 450,000-Psf capacity mineral oil test machine.

### Pullout Resistance

49. Moderately hard siltstone cores with nominal diameters of 6 in. were placed upright in 30-in.-diameter cardboard molds. A concrete mixture having the approximate compressive strength of the siltstone was placed into the mold embedding the core to its full height. The concrete served two purposes. First, it acted as a resistance block allowing the rebar to be pulled, and second, it served as a host material in case the core instead of the rebar was pulled out.

50. After the concrete had cured and attained the 28-day strength (2710 psi), a 1-in.-diameter hole was drilled in the center of the siltstone core. A diamond thin-wall bit was used resulting in a smooth-walled borehole. A No. 4 rebar was grouted the full depth of the core using a commercially available premixed grout for anchoring bolts and dowels. Grout strength at test time was 5230 psi. After the grout attained a 15-day strength, the bars were pulled using the setup illustrated in Figure 5. Total weight of the suspended specimen was taken into account in calculating the bond stress.

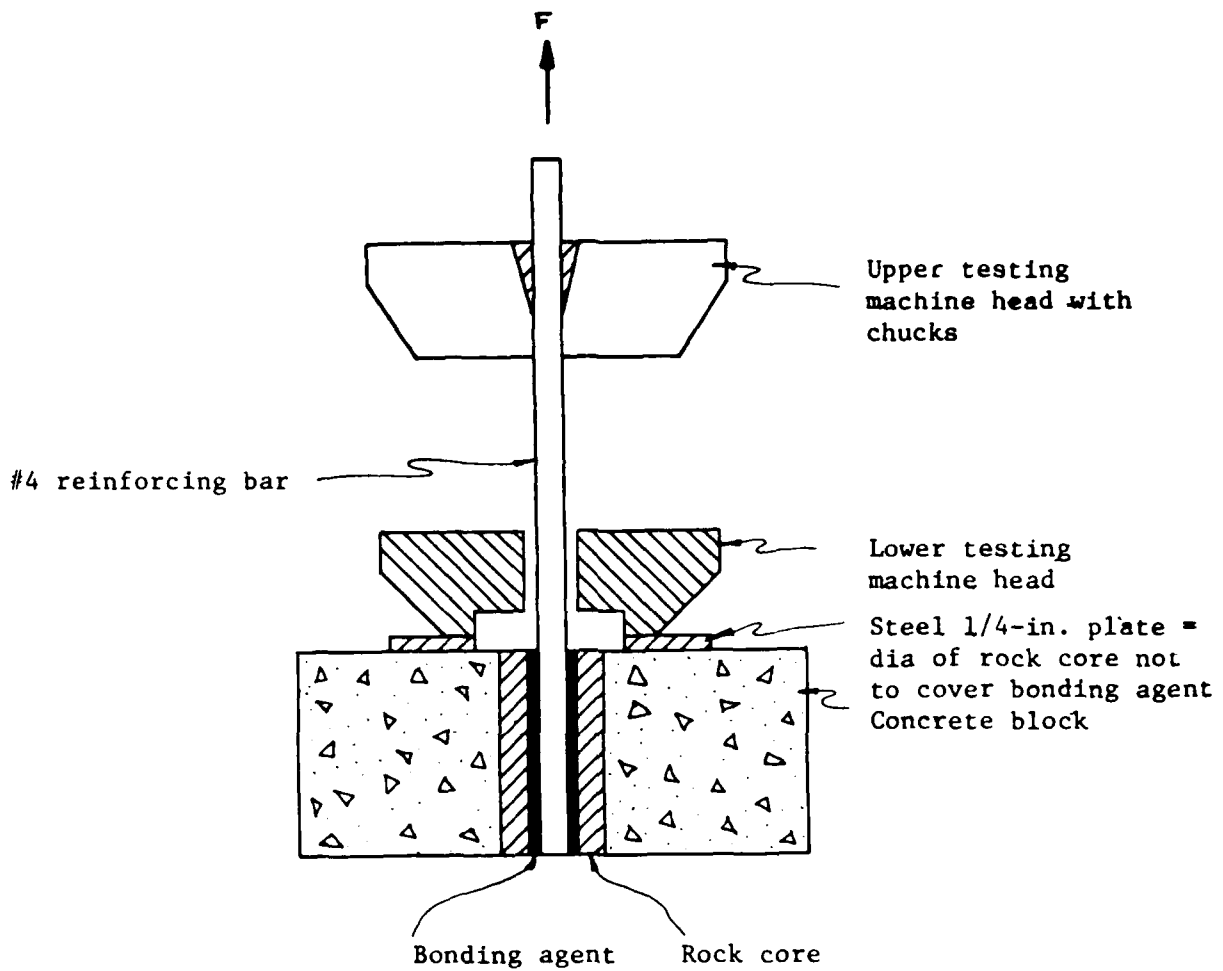

Figure 5. Section showing test configuration for the reinforcing bar pullout tests.

## PART VI: TEST RESULTS AND DISCUSSION

### Petrographic Examination

51. The petrographic examination accomplished the following: (a) identified the aggregates in the concrete overlays and in the original concrete, (b) identified the processes causing distress and failure in the concrete, and (c) determined the extent of damage in all cores. Pieces of core from 63 percent of the 27 borings were examined in detail; see Appendix C for detailed results of the examination.

### Concrete Aggregates

52. The concrete overlay (assumed to have been applied in 1942) on the land and river wall contains 1/4- to 1/2-in. maximum size aggregate, is air entrained, and generally darker in color than the older concrete. Average overlay thicknesses observed in the land and river wall cores are 0.6 ft and 0.5 ft, respectively.

53. The original concrete is not air entrained. It is composed of 2-1/2-in. nominal maximum size natural gravel and natural sand. The gravel consists predominantly of sandstone and chert with minor amounts of limestone and coal. This composition is common for gravels and sands from the region. The concrete is well consolidated and quite similar throughout the lock structure.

### Cause of Concrete Damage

54. The overlay concrete is in generally good condition; some air voids are lined with varying amounts of alkali-silica reaction products.

55. The major processes causing concrete in the lock structure to crack and break up are cycles of freezing and thawing and alkali-silica reaction. It was not within the scope of this investigation to determine which one of these processes occurred first, or which process has caused the most damage to the concrete.

56. Evidence of freezing and thawing is manifested in the cores by closely spaced parallel cracks; such cracking occurred in all but a few of the cores. Scaling of the mortar and spalling of the concrete were also observed on the exposed ends of the cores. Evidence of alkali-silica reaction was observed in the form of efflorescence, pattern and random cracking, expansion, chalky crack surfaces, and rings around aggregates. Some white reaction material occurred on most cracked core surfaces, especially in areas where broken and rubble concrete was found.

#### Extent of Damage

57. The extent of the concrete damage observed in the cores during the petrographic examination is included under the subheading Concrete Quality. By doing so, the extent of concrete damage seen in all the cores will be discussed at one time.

#### Reinforcing Bar Pullout Resistance

58. Per instructions, the pullout resistance tests were conducted on cores recovered from the second siltstone bed encountered in the borings. Cores from between elevations 725.0 and 721.9 were selected. A siltstone specimen from El 724.9 was tested for compressive strength; the strength is 3180 psi.

59. The tabulations below present the failure mode and the pullout loads of the test specimens.

#### Failure Mode of Pullout Specimens

<u>Specimen No.</u>	<u>Failure Mode</u>
L-12-82, 78.0 ft - 78.9 ft	Reinforcing bar failed, 1/4-in. rock
L-10-82, 78.7 ft - 79.5 ft	Reinforcing bar failed, 1/4-in. rock
L-12-82, 80.1 ft - 81.1 ft	Reinforcing bar failed, 1/4-in. rock

Pullout Loads of Test Specimens

Specimen No.	Core		Hole		Pullout Strength	
	Diameter, in.	Diameter, in.	Length, in.	Surface Area, in. <sup>2</sup>	Total Load, lbf	Pounds per foot
L-12-82, 78.0 ft - 78.9 ft	5.95	1.0	10.44	32.80	17,600	20,000
L-10-82, 78.7 ft - 79.5 ft	5.95	1.0	9.36	29.41	17,900	23,000
L-12-82, 80.1 ft - 81.1 ft	5.95	1.0	12.24	38.45	18,200	18,000

60. Using a minimum pullout resistance of 18,000 lb/ft and a safety factor of 2, an allowable of 9000 lb/ft is obtained for the specimens tested. The minimum pullout resistance of the grout plug was governed by the rebar failure. The pullout resistance of the moderately hard siltstone beneath the coal is:

$$\frac{9000 \text{ lb/ft}}{A} = \frac{9000 \text{ lb/ft}}{37.7 \text{ sq in.}} = 240 \text{ psi}$$

where A is the area between the grout and rock in a 1-in.-diameter hole 1 ft long.

Peak and Residual Shear Strength

61. Direct shear tests on intact indurated clay were conducted to confirm previous Missouri River Division (MRD) Laboratory direct shear test results on the same type of rock. MRD's direct shear test results are presented in their report entitled (U. S. Army Engineer Missouri River Division 1976).

62. A summary of the direct shear test results of foundation core is presented in Table 4. Six intact, three precut concrete on rock, and nine concrete bonded to rock specimens specimens were run in the WES direct shear device. Individual test results, wet density, and moisture contents are presented in Plates 3-6. The shear stress versus shear deformation and the normal versus shear deformation curves are presented in Plates 7-42. The shear stress/normal stress values and failure

envelopes obtained on intact indurated clay are presented in Figure 6. Figure 6 contains similar data and failure envelopes from the above-cited MRD report for comparative purposes. Both the WES and MRD data were obtained on indurated clay ranging in hardness from soft to medium hard.

63. Figure 6 illustrates that the WES peak shear stress values fall reasonably well within the scatter exhibited by the MRD's peak shear stress data. We, therefore, think that the average peak shear strength,  $\phi$  angle (32 degrees), and cohesion (4 tsf) presented by the MRD are reasonable for soft to moderately hard indurated clay.

64. The residual shear stress values plot just above the spread of the MRD data for a given normal stress. Additional testing would be required to determine the reason for the higher residual values obtained at the WES. The average residual shear angle of 15 degrees obtained by the MRD is a reasonable value for this type of indurated clay.

65. Moderately hard indurated clay specimens were used for the direct shear tests on concrete bonded to natural rock surfaces. Specimens were split along natural bedding planes and concrete placed on the bedding surface.

66. Six specimens of concrete bonded to indurated clay were tested at 1.8-, 3.6-, and 7.2-tsf normal stress. The test results produced reasonable peak failure envelopes with slopes of 53 and 55 degrees and cohesion intercepts of 16.9 and 8.3 tsf, respectively (see Figure 7). Three specimens did not produce a reasonable failure envelope. The residual shear strengths from all nine tests were used to determine an average residual shear strength envelope; the angle of sliding friction is 26 degrees and the cohesion is 0.9 tsf.

67. Three precut concrete on indurated clay specimens were tested to determine lower bound shear strength parameters; see Figure 7. The results yield a reasonable failure envelope with an angle of sliding friction of 18 degrees and a cohesion of zero. The 18-degree friction angle correlates well with the residual  $\phi$  angle of 15 degrees obtained during the MRD testing in 1976 on intact indurated clay.

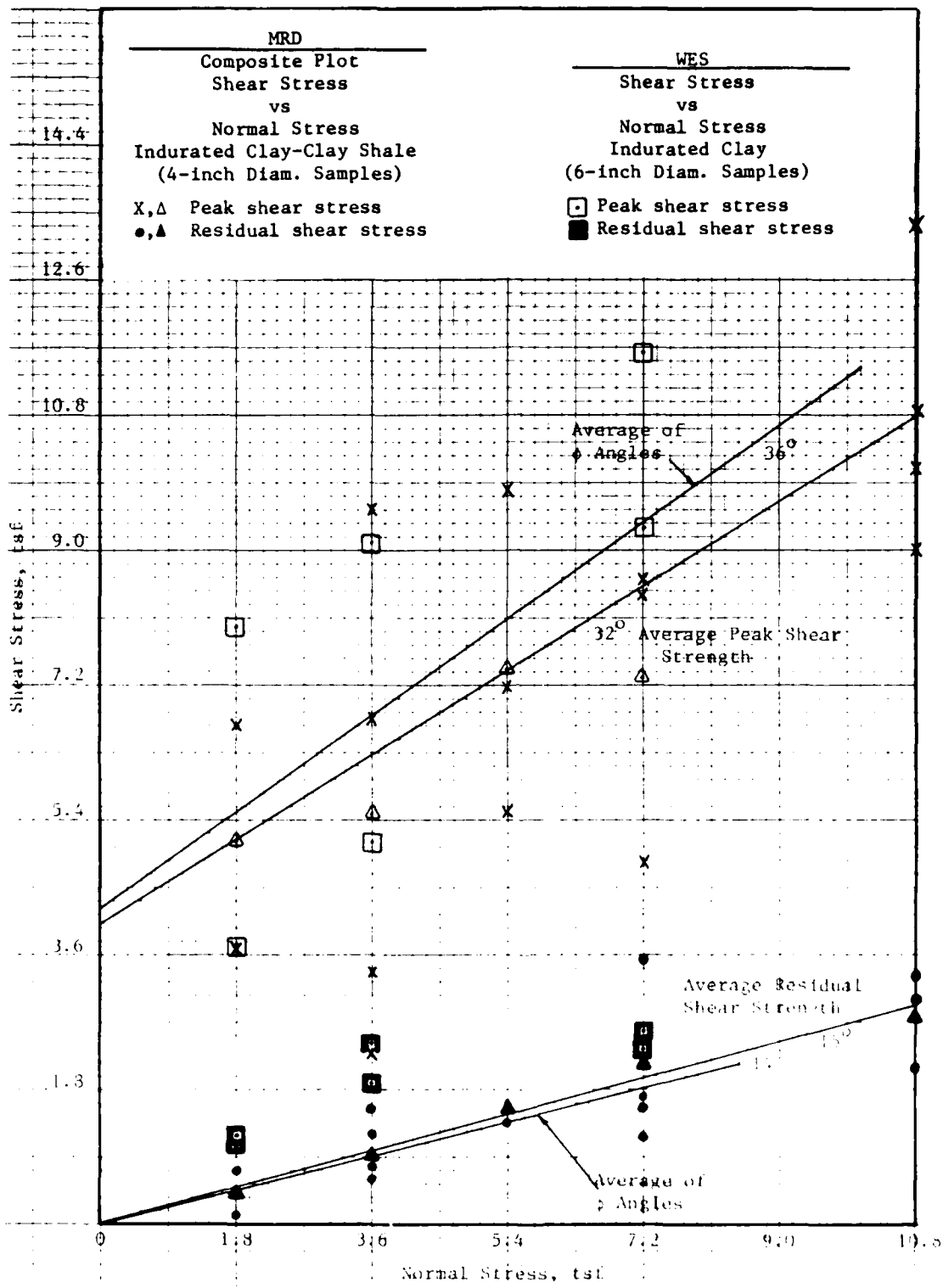

Figure 6. Direct shear test results - failure envelopes, indurated clay

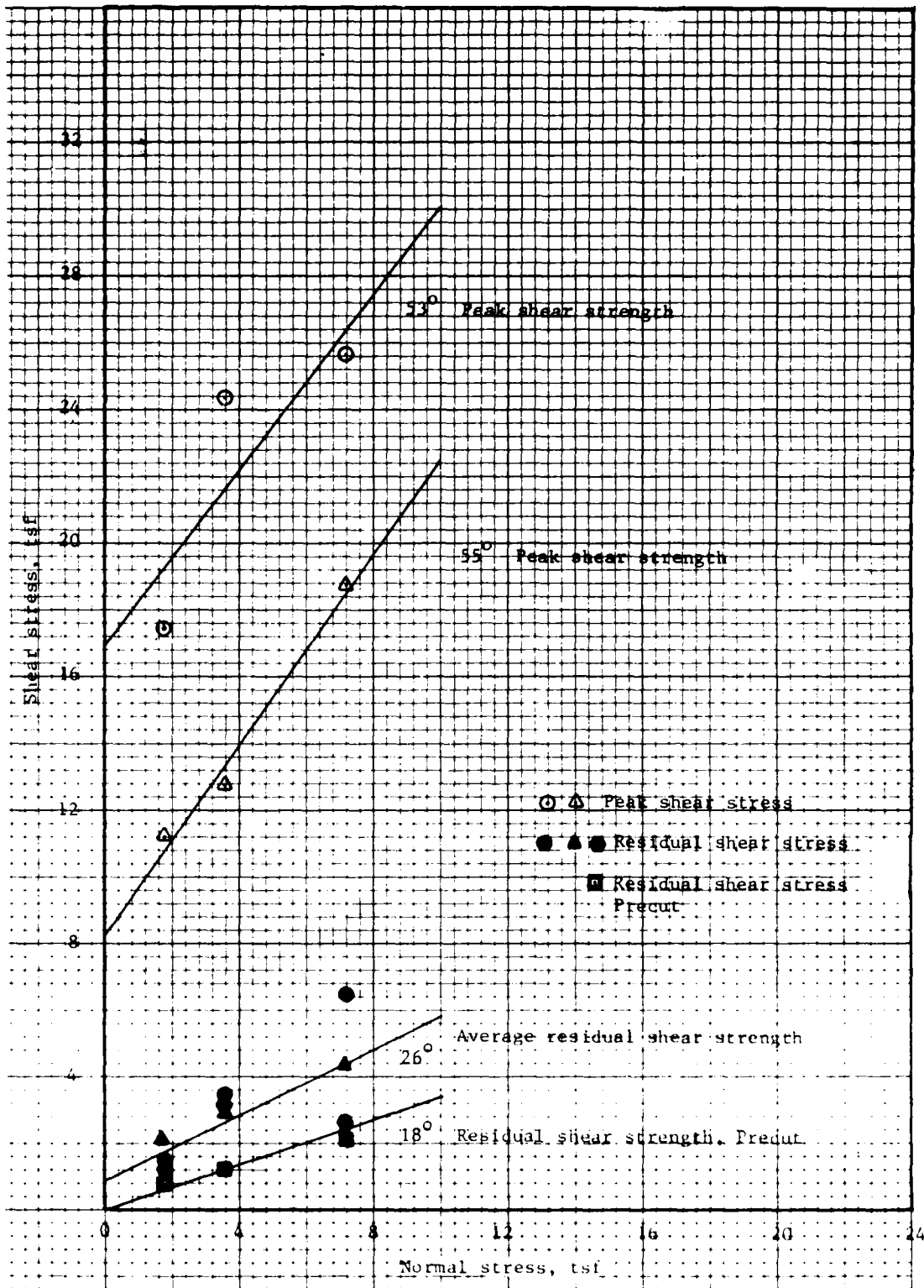

Figure 7. Direct shear test results - failure envelopes, concrete bonded to indurated clay and precut concrete on indurated clay

## Concrete Quality

68. The quality of the concrete in the lock was evaluated using information obtained during the inspection of the lock, field and detailed core logs, petrographic examination results, and characterization and engineering design test results. The quality of the near-surface and internal concrete will be discussed by structural elements, i.e., guide walls, guard walls, land lock wall, and river lock wall. Table 5 presents the characterization and engineering design test results obtained on the concrete core. Plots of the stress-strain relation for selected concrete cores are presented in Plates 43 through 52.

### Guide Walls

69. The top surface of the upper and lower guide walls appears to be good quality concrete.

70. One vertical boring, L-7-82, was drilled in the upper guide wall. The core in L-7-82 reveals a 0.5-ft overlay (see Figure 4); beneath the overlay to a depth of 2.5 ft, the concrete is in very poor condition. The core shows in-place rubble beneath the overlay to 1.5 ft and cracked concrete to 2.5 ft. Most broken surfaces contain deposits of alkali-silica gel proving that the concrete damage occurred in-place. The concrete beneath the damaged zone and to the bottom of the boring (8.4 ft) is good quality concrete with plus 5000-psi compressive strengths. Presented in Plate 53 is a summary log of boring and selected concrete properties of core from boring L-7-82. Plate 54 shows the typical top surface of the guide walls. Plate 55 is a photograph of near-surface core for L-7-82 showing the interval of rubble (missing in the photo) and cracked concrete.

71. Four horizontal borings were drilled in the guide walls, one in the upper and three in the lower guide wall. Boring Gi-3-82 in the upper guide wall reveals 0.4 ft of concrete cracking due to frost damage; the remainder of the core is good quality concrete. Plate 56 shows the

summary log of boring and selected concrete properties of core from boring Gi-3-82; Plate 57 presents core photographs from this boring.

72. The horizontal borings in the lower guide wall have frost damage to a maximum depth of 1.2 ft; one core shows no damage. The concrete beyond the damaged zones is good quality concrete and has strengths greater than 3800 psi. Plates 58 and 59 illustrate the summary log of borings and physical property data of core from the borings in the lower guide wall.

73. The tabulation below summarizes the depth of damaged concrete for the five borings in the guide walls.

Structural Element	Boring No. PM-WES	Boring Direction		Damaged Concrete Depth ft
		Horiz	Vert	
Guide Wall, lower	Gi-1-82	X		0.0-1.2
Guide Wall, upper	Gi-3-82	X		0.0-0.4
Guide Wall, lower	Gi-4-82	X		0.0-0.9
Guide Wall, lower	Gi-5-82	X		None
Guide Wall, upper	L-7-82		X	0.5-2.5

#### Guard Walls

74. The top surface of the guard walls appears to be fair to good quality concrete.

75. Three vertical borings, L-11-82, L-17-82, and L-18-82 were drilled in the guard walls. The three borings show a concrete overlay from 0.4 to 0.6 ft in thickness. Beneath the overlay and to a depth of 1.1, 1.6, and 3.0 ft in L-11-82, L-17-82, and L-18-82, respectively, the concrete is in very poor condition; within these depth intervals the concrete is broken into rubble and highly cracked. Most all broken and cracked surfaces contain deposits of alkali-silica gel, showing that the concrete was damaged in-place. The concrete beneath the damage zones

is good quality material with plus 6200-psi compressive strength. Presented in Plates 60 and 61 are summary logs of borings; Plate 61 contains selected concrete properties of core. Plates 62 and 63 show photographs of the poor quality near-surface concrete in borings L-11-82 and L-17-82.

76. Two horizontal borings were drilled in the guard walls, one each in the upper and lower wall (chamber side). No damage was observed in either core except a small amount of surface spalling. Plate 64 is a summary log of borings with selected physical properties for borings Ga-1-82 and Ga-3-82. The absence of damage in these two core borings does not mean that near-surface concrete damage is absent in the guard walls; Photographs 11 and 12 in Appendix A illustrate extensive surface damage. Additional borings in the guard walls are suggested to check for near-surface concrete damage; i.e., horizontal borings several feet in depth would suffice.

77. The tabulation below summarizes the depth of damaged concrete for the five borings in the guard walls.

<u>Structural Element</u>	<u>Boring No. PM-WES</u>	<u>Boring Direction</u>		<u>Damaged Concrete Depth ft</u>
		<u>Horiz</u>	<u>Vert</u>	
Guard Walls	Ga-1-82	X		None
	GA-3-82	X		None
	L-11-82		X	0.6-3.0
	L-17-82		X	0.5-1.6
	L-18-82		X	0.4-1.1

#### Land Lock Wall

78. The top surfaces of the lock wall appear to be in fair to good condition. The three vertical borings in this wall show very poor quality concrete (broken and cracked) to a maximum depth of 2.7 ft. One boring shows sound concrete to a depth of 12.3 ft. Most broken and cracked surfaces have partial coatings of alkali-silica gel. Concrete beneath the damaged zone is considered good quality concrete.

79. Vertical boring L-1-82 is located in the upper miter gate monolith block, L-3-82 at about mid-length of the wall, and L-5-82 near the operations building. Concrete overlay between 0.3 and 0.6 ft was recovered in two borings; local overlay depths can be expected to vary by several tenths of a foot.

80. Boring L-1-82 is located about 25 ft downstream from the location of the horizontal boring Gi-2-82 which has rubble to a 3-ft depth. The concrete in L-1-82 is broken from beneath a 0.3-ft overlay to a depth of 1.5 ft.

81. Boring L-3-82 reveals no overlay but has broken and cracked concrete to a depth of 2.3 ft. Some of the broken core can be attributed to pieces of rebar that tumbled in the core barrel during drilling. Boring L-5-82 reveals a 0.6-ft-thick concrete overlay and broken core to a depth of 2.7 ft; the concrete physical property test results indicate good quality concrete beneath the damage zones. Minimum and maximum strengths are 2690 and 6270 psi, respectively; the lower strength concrete is near the bottom of the wall. Plates 65 and 66 illustrate the summary log of boring and selected concrete properties from borings L-1-82 and L-5-82. Plates 67 and 68 show photographs of the near-surface core from the three vertical borings in the land lock wall.

82. Six horizontal borings were drilled in the land lock wall, chamber side; three high (near upper pool elevation, termed high borings) and two low (near lower pool elevation, termed low borings). The core from the high borings showed deeper concrete damage than the low borings. Maximum depth of damage was 1.3 ft and 0.4 ft for the high and low borings, respectively. The majority of the damage was cracking from freezing and thawing cycles. Crack surfaces were partially or fully coated with alkali-silica gel. The concrete beyond the damage zones is of good quality concrete. Plates 69, 70, and 71 illustrate summary log of borings for the five horizontal borings located in the land lock wall. Plates 72 and 73 present photographs of concrete core from these same five borings.

83. Boring Gi-2-82 was drilled in the upper miter gate recess about 3 ft upstream from the sector pin and at about the top elevation of the anchorage for the sector pin assembly; see Plates 74 and 75 for details.

The full 3-ft core is in very poor condition being broken into 2- to 3-in. pieces; several pieces are hand size. Most all pieces contained partial to complete coatings of alkali-silica gel.

84. To get an idea of the extent of the in-place concrete damage adjacent to the Gi-2-82 boring, a vertical boring was drilled about 7 ft upstream of this location. Sound concrete was recovered. Additional drilling is recommended to zone and verify the damaged concrete revealed in Gi-2-82. Considering the surface concrete damage seen in Figures 1a-d, it is possible that very poor quality concrete exists in one or more of the miter gate recesses. Operational problems with the gates could occur if damaged concrete is extensive adjacent to the gate machinery.

85. The tabulation below summarizes the depth of damaged concrete for the eight borings in the land lock wall:

<u>Structural Element</u>	<u>Boring No.</u> PM-WES	<u>Boring Direction</u>		<u>Damaged Concrete Depth, ft</u>
		<u>Horiz</u>	<u>Vert</u>	
Land Lock Wall	L-2-82	X		0.0-0.4
Land Lock Wall	L-4-82	X		0.0-0.4
Land Lock Wall	L-6-82	X		None
Land Lock Wall	L-13-82	X		0.2-0.5
Land Lock Wall	L-14-82	X		0.5-1.3
Land Lock Wall (gate recess)	Gi-2-82	X		0.0-3.0
Land Lock Wall	L-1-82		X	0.3-1.5
Land Lock Wall	L-3-82		X	0.0-2.3
Land Lock Wall	L-5-82		X	0.6-2.7
Land Lock Wall	L-19-82		X	None

#### River Lock Wall

86. The top surface of the river lock wall appears to be in fair to good condition. One of the two vertical cores (L-12-82) recovered from the wall reveals very poor quality concrete (broken and cracked) to 2.5 ft; one core (L-10-82) has no detectable damage. Some of the broken surface has partial coatings of alkali-silica gel. Concrete beneath the damage concrete is considered good quality concrete.

87. Vertical boring L-10-82 is in the upper miter gate monolith while L-12-82 is at about mid-length of the lock wall. The two borings contain no overlay; both core have 2-1/2- to 3.0-in. maximum size aggregates. The internal concrete has a minimum and maximum strength of 2950 and 5200 psi, respectively. These strength values represent the full depth of concrete in the wall.

88. Plates 65 and 76 present the summary log of borings and selected concrete physical properties for the two vertical borings. Plate 77 presents photographs of the near-surface concrete core from L-10-82 and L-12-82.

89. Five horizontal borings were drilled in the river lock wall, chamber side; three high and two low borings. As was the case in land lock wall, the core from the high borings showed deeper concrete damage than core from the low borings. Maximum depth of damage was 1.9 ft and 1.0 ft for the high and low borings, respectively. Except in the high boring Ga-2-82, the damage observed in the core is due to subparallel cracking caused by freezing and thawing action.

90. Boring Ga-2-82 is located in the upper miter gate monolith. The core from this boring is broken and cracked to a depth of 1.9 ft. Most of the broken pieces are partially coated with alkali-silica gel indicating that breakage of the concrete occurred in-place. Boring Ga-2-82 is the second horizontal boring in a miter gate monolith that shows very poor quality concrete. The upper miter gate recess in the land lock wall contains similar poor quality concrete.

91. Horizontal borings in the river wall, river side, were not made. It is assumed that the depth of concrete damage on the river side of the river lock wall would be similar to the depth of damage observed in the core taken from the chamber side. The internal concrete in the river lock wall is considered to be of good quality. Compressive strengths of core from the horizontal borings range from 4820 to 5800 psi.

92. Plates 78, 79, and 80 illustrate the summary log of borings and selected physical properties of core from the five horizontal borings in the river lock wall. Plates 81 and 82 present the photographs of the core from the horizontal borings in the river lock wall.

93. The tabulation below summarizes the depth of damaged concrete for the seven borings made in the river lock wall:

<u>Structural Element</u>	<u>Boring No. PM-WES</u>	<u>Boring Direction</u>		<u>Damaged Concrete Depth, ft</u>
		<u>Horiz</u>	<u>Vert</u>	
River Lock Wall	GA-2-82	X		0.0-1.9
River Lock Wall	L-8-82	X		0.0-1.0
River Lock Wall	L-9-82	X		0.5-0.8
River Lock Wall	L-15-82	X		0.0-0.9
River Lock Wall	L-16-82	X		0.0-0.6
River Lock Wall	L-10-82		X	None
River Lock Wall	L-12-82		X	0.0-2.5

## PART VII: CONCLUSIONS, SUMMARY, AND RECOMMENDATIONS

### Conclusions and Summary

94. The processes causing the greatest amount of distressed and failed concrete are freezing and thawing action and alkali-silica reaction. Both of these processes will continue at accelerated rates if adequate repairs or replacement of the damaged concrete are not carried out.

95. Concrete damage is considered extensive in the guide, guard, and lock walls. The top concrete surfaces of the guide, guard, and lock walls are in fair to good condition. Concrete deficiencies are present on all of these top surfaces; e.g., a few small and large spalls, a few areas of light to very severe scaling, transverse and longitudinal cracks, and small areas of random and pattern cracking. These defects exist in the concrete overlays and in the original concrete.

96. Low quality concrete to a minimum depth of 1.1 ft and to a maximum depth of 3.0 ft was observed in 80 percent of the vertical borings placed in the guide, guard, and lock walls. As observed in the vertical borings, the average depth of low quality concrete is 2.2 ft. The low quality concrete is present as either rubble, broken pieces less than 3 in. in size, or cracked pieces 3 to 10 in. thick.

97. The vertical surfaces of the guide, guard, and lock walls above upper and lower pool elevations are in poor to very poor condition. About 70 percent of the land and river chamber walls is spalled to depths up to 8 in., average depth about 4 in.. All vertical monolith joints are spalled from lower pool elevation to the corner armor; 12-in.-deep spalls are common in these joints. The remaining 30 percent of the chamber walls contain scaled and spalled areas and horizontal and random cracks.

98. Low quality concrete to a minimum depth of 0.4 ft and to a maximum depth of 3.0 ft was observed in 76 percent of the horizontal borings placed in the guide, guard, and lock walls. As observed in the horizontal borings, the average depth of low quality concrete is 1.0 ft. The physical condition of the low quality concrete in the horizontal borings is the same as observed in the vertical borings.

99. For those low quality concrete zones where rubble and pieces <3 in. in size occur, this material occupies about 60 percent of the zone. The remainder of the zone contains cracked concrete resulting in pieces of core ranging from 3 to 10 in. thick. The majority of the cores reveal damage due to subparallel cracking due to freezing and thawing action.

100. The two upper miter gate recess monoliths contain rubble, broken, and cracked concrete. The most severe concrete condition exists in the land wall upper miter gate recess. The damaged concrete is at least 3 ft from the sector pin assembly and extends to a detectable depth of 3 ft from the recess face. The cracked and broken near-surface concrete is subject to further deterioration by continued freezing and thawing and possible alkali-silica reaction. This very poor quality concrete presents a very serious safety problem. Additional deterioration might cause the concrete adjacent to or in the sector pin anchorage area to lose its load-carrying capability. If not repaired, continued deterioration might jeopardize the structural integrity of the gate recess.

101. About one-half of the broken and cracked surfaces of concrete core were partially or fully coated with alkali-silica gel, thus showing damaged occurred in-place. This white reaction product was observed throughout all cores. It was not within the scope of this investigation to determine if the alkali-silica reactivity is continuing or has terminated. If it is ongoing, then it is assumed to be occurring slowly.

102. Infiltrating water into the scaled and spalled areas and cracked concrete at the lock will continue to cause critical saturation levels in the concrete. As this level is reached, and freezing and thawing action occurs, the concrete will be further deteriorated.

103. The ability of the surface and near-surface concrete to perform satisfactorily under anticipated conditions of future service is in serious question. It is not now performing its originally intended purpose.

104. Concrete beneath the damaged zone is of good quality. The lowest compressive strength obtained on concrete core from internal sections of the guide, guard, and lock walls is 2690 psi. The average

compressive strength of 30 cores is 4870 psi with a standard deviation of 1182 psi. Indications are that the internal concrete should remain in serviceable condition for a period extending on the order of 50 years.

105. A hazard exists in the lock chamber. Some of the remaining shotcrete overlay protrudes from the walls. Boats and barges could catch on these protrusions causing them to break off and could result in property damage or personal injury.

106. The direct shear tests on intact indurated clay conducted at the WES confirm previous MRD Laboratory direct shear test results. Peak and residual shear strengths presented by the MRD appear reasonable for the indurated clay samples recovered from the lock and dam site.

107. The lithologic units identified in the WES borings and those identified in previous borings drilled by the Pittsburgh District correlate quite well. No significant lithologic differences exist nor are any structural feature differences apparent in the borings made by the two drilling agencies. The three vertical borings through the lock walls show the walls to be founded on the soft gray indurated clay. A high percentage of this rock unit was broken during drilling.

#### Recommendations

108. It is recommended that ultrasonic testing be conducted in the four miter gate recesses to determine if in-place broken and cracked concrete exists adjacent to the gate machinery anchorage. A limited amount of drilling would be anticipated to verify some of the ultrasonic test results. The gate recesses are the only concrete areas at the lock that should be examined further.

109. If the lock is to be rehabilitated, it is recommended that all damaged concrete be removed to its full depth and replaced by high quality frost-resistant concrete.

#### REFERENCES

U. S. Army Engineer District, Pittsburgh. 1979 (Sep). "Lock and Dam 8, Monongahela River, Pennsylvania, Third Periodic Inspection Report," Pittsburgh, Pa.

U. S. Army Engineer District, Pittsburgh. 1972 (Jun). "Lock and Dam 8, Monongahela River, Pennsylvania, First Periodic Inspection Report," Pittsburgh, Pa.

American Concrete Institute. 1980. "Guide for Making a Condition Survey of Concrete in Service," ACI Manual of Concrete Practice, ACI 201.1R-68, Detroit, Mich.

U. S. Army Engineer Waterways Experiment Station, CE, 1980 "Rock Testing Handbook," Test Standards, Vicksburg, MS.

U. S. Army Engineer Missouri River Division. 1976 (Aug). "Direct Shear and Unconfined Compressive Strength Tests and Index Properties of Foundation Rock," Point Marion (Lock 8), Monongahela River, Omaha, Nebr.

Table 1  
Engineering Information and Data  
Lock No. 8, Mon River

---

Holes OL-1 to OL-3; OL-4 to OL-5  
M-48-22a Survey of Site  
M-82-1 Plans, Elevations & Sections  
M-82-1 Sections, Lock Walls  
M-82-2 Core, Guide & Guard Walls, Plans, Elevations & Sections  
037-L8-10/2 Core Borings Plans  
037-L8-10/3.1 Profile on Line A-A  
037-L8-10/4.1 Profile on Line A-A  
037-L8-10/5 Profile on line B-B, C-C, & D-D; Sections E-E and F-F  
037-L8-10/8 Borings Plan  
037-L8-20/1.1 Anchorage of Miter Sills  
037-L8-20/2.1 River Wall Anchorage & Refacing  
037-L8-20/3.1 River Wall Anchorage & Refacing  
037-L8-40/1.1 General Plan & Elevation  
037-L8-40/2.1 Treatment of Sill & Fixed Weir  
037-L8-40/4.1 Elevation & Sections  
037-L8-40/6 Piers No. 1 to 7 incl., Reinforcing Details  
Final Report, Movable Crest, Dam #8, Mon. River  
Foundation Report #1 - River Lock Wall, Miter Sills, Sta 0+00 to 2+60.0  
Foundation Report #2 - Dam, Sta 2+60 to Sta 5+60 and Abutment  
Change Order, Contract DA-36-058-CIVENG-58-64, Modifications #2 thru #17  
Direct Shear & Unconfined Compressive Strength Tests and Index of Properties of Fda. Rock  
DF - Abutment Slide  
Chart #14  
Piezometer Readings  
Periodic Reports L/D 8, Report 1, 2, and 3  
Drilling Logs L-1 thru L-4, D-1, D-2A, thru D-7; A-1 thru A-10  
Drillers Log Book pages on OL-1 thru OL-5  
L/D 8 Precise Alignment & Settlement - Dam, Land Wall and River Wall  
Color Photos L/D 7 and L/D 8

---

Table 2  
Pertinent Boring Information

Boring No. PM-WES	Monolith No.	Boring Depth ft	Core Size in.	Direction of Boring	Elev Top of Boring ft	Elev Top of Rock ft	Elev Bottom of Boring ft
L-1-82	L-12	51.4	6	V	803.1	759.7	751.6
L-2-82	L-13	3.0	6	H	783.0		
L-3-82	L-17	8.4	6	V	803.1		794.7
L-4-82	L-18	2.0	6	H	784.0		
L-5-82	L-20	5.1	6	V	803.1		798.0
L-6-82	L-13	2.0	6	H	793.0		
L-7-82	L-5	9.0	6	V	803.1		794.1
L-8-82	R-10	3.4	6	H	784.0		
L-9-82	R-4	3.0	6	H	784.0		
L-10-82	R-4	87.5	6	V	803.1	761.7	715.6
L-11-82	R-2	7.8	4	V	803.1		795.3
L-12-82	R-10	81.5	6	V	803.1	759.5	721.6
L-13-82	L-17	2.0	6	H	798.1		
L-14-82	L-20	1.6	6	H	792.1		
L-15-82	R-9	3.2	6	H	798.0		
L-16-82	R-13	3.2	6	H	792.0		
L-17-82	R-14	8.4	4	V	803.1		794.7
L-18-82	R-16	7.0	4	V	803.1		796.1
L-19-82	L-12	12.3	6	V	801.0		788.7
Ga-1-82	R-2	3.0	6	H	799.0		
Ga-2-82	R-4	3.1	6	H	799.2		
Ga-3-82	R-15	3.0	6	H	783.5		
Gi-1-82	L-22	2.9	6	H	784.0		
Gi-2-82	L-12	3.1	6	H	799.8		
Gi-3-82	L-5	3.2	6	H	783.5		
Gi-4-82	L-27	1.9	6	H	783.5		
Gi-5-82	L-31	3.0	6	H	782.5		

Table 3

## Pertinent Core Information

Boring No.	Box No.	Depth, ft	Elev		Elev Bottom of Boring	Structures Laboratory Identification No.
			Top of Boring	Top of Rock		
PM-WES-L-1-82	1 of 14	0.0- 4.0	803.1	759.7	751.6	PITT-10 CON-1 a-e
	2 of 14	4.0- 8.1				PITT-10 CON-2 a-c
	3 of 14	8.1-10.2				PITT-10 CON-3
	4 of 14	10.2-13.7				PITT-10 CON-4
	5 of 14	13.7-18.1				PITT-10 CON-5 a,b
	6 of 14	18.1-20.9				PITT-10 CON-6
	7 of 14	20.9-25.0				PITT-10 CON-7 a,b
	8 of 14	25.0-28.4				PITT-10 CON-8 a,b
	9 of 14	28.4-32.7				PITT-10 CON-9 a-d
	10 of 14	32.7-37.1				PITT-10 CON-10 a-d
	11 of 14	37.1-41.2				PITT-10 CON-11 a,b
	12 of 14	41.2-46.3				PITT-10 DC-1
	13 of 14	46.3-50.4				PITT-10 DC-2 a-d
	14 of 14	50.4-51.4				PITT-10 DC-3
PM-WES-L-2-82	1 of 1	0.0- 3.0	783.0			PITT-10 CON-12 a-e
PM-WES-L-3-82	1 of 3	0.0- 2.3	803.1		794.7	PITT-10 CON-13
	2 of 3	2.3- 5.8				PITT-10 CON-14 a-c
	3 of 3	5.8- 8.4				PITT-10 CON-15 a-c
PM-WES-L-4-82	1 of 1	0.0- 2.05	784.0			PITT-10 CON-16 a,b
PM-WES-L-5-82	1 of 2	0.0- 4.1	803.1		798.0	PITT-10 CON-17 a,b
	2 of 2	4.1- 5.1				PITT-10 CON-18 a,b
PM-WES-L-6-82	1 of 1	0.0- 2.0	793.0			PITT-10 CON-19
PM-WES-L-7-82	1 of 3	0.0- 3.5	803.1		794.1	PITT-10 CON-20 a-d
	2 of 3	3.6- 7.3				PITT-10 CON-21 a,b
	3 of 3	7.3- 9.0				PITT-10 CON-22
PM-WES-L-8-82	1 of 1	0.0- 4.0	784.0			PITT-10 CON-23 a-d
PM-WES-L-9-82	1 of 1	0.0- 3.0	784.0			PITT-10 CON-24 a,b

(Continued)

Table 3 (Continued)

Boring No.	Box No.	Depth, ft.	Elev		Elev Bottom of Boring	Structures Laboratory Identification No.
			Top of Boring	Top of Rock		
PM-WES-1-10-82	1 of 22	0.0- 4.6	803.1	761.7	715.6	PITT-10 CON-25 a-d
	2 of 22	4.6- 8.2				PITT-10 CON-26 a-d
	3 of 22	8.2-11.6				PITT-10 CON-27 a,b
	4 of 22	11.6-15.3				PITT-10 CON-28 a-c
	5 of 22	15.3-18.5				PITT-10 CON-29 a-c
	6 of 22	18.5-22.9				PITT-10 CON-30 a-c
	7 of 22	23.0-27.0				PITT-10 CON-31 a-d
	8 of 22	27.0-31.8				PITT-10 CON-32 a-e
	9 of 22	32.0-35.8				PITT-10 CON-33 a-f
	10 of 22	35.7-40.0				PITT-10 CON-34 a-c
	11 of 22	40.0-44.0				PITT-10 CON-35, DC-4 a-d
	12 of 22	44.0-49.3				PITT-10 DC-5 a-d
	13 of 22	49.3-53.8				PITT-10 DC-6 a-f
	14 of 22	53.8-58.2				PITT-10 DC-7 a-f
	15 of 22	58.2-62.5				PITT-10 DC-8 a-c
	16 of 22	62.5-64.9				PITT-10 DC-9 a-c
	17 of 22	64.9-69.2				PITT-10 DC-10 a-e
	18 of 22	69.2-73.8				PITT-10 DC-11 a-g
	19 of 22	73.8-77.6				PITT-10 DC-12 a-c
	20 of 22	77.6-82.1				PITT-10 DC-13 a,b
	21 of 22	82.1-86.5				PITT-10 DC-14 a-d
	22 of 22	86.5-87.5				PITT-10 DC-15
PM-WES-L-11-82	1 of 1	0.0- 7.8	803.1		795.3	PITT-10 DC-16
PM-WES-L-12-82	1 of 19	0.0- 4.6	803.1	759.5	721.6	PITT-10 CON-36 a-f
	2 of 19	4.6- 8.9				PITT-10 CON-37 a-c
	3 of 19	8.9-13.1				PITT-10 CON-38 a-c
	4 of 19	13.1-17.4				PITT-10 CON-39 a,b
	5 of 19	17.4-21.5				PITT-10 CON-40 a,b
	6 of 19	21.5-25.7				PITT-10 CON-41 a-c
	7 of 19	25.7-29.9				PITT-10 CON-42 a-c
	8 of 19	29.9-34.2				PITT-10 CON-43 a,b
	9 of 19	34.2-38.9				PITT-10 CON-44 a,b
	10 of 19	38.9-42.8				PITT-10 CON-45

(Continued)

Table 3 (Concluded)

Boring No.	Box No.	Depth, ft	Elev		Structures Laboratory Identification No.
			Top of Boring	Top of Rock	
	11 of 19	42.8-47.0			PITT-10 CON-46, DC-16 a,b
	12 of 19	47.0-51.2			PITT-10 DC-17 a-f
	13 of 19	51.2-55.8			PITT-10 DC-18 a-d
	14 of 19	55.8-60.6			PITT-10 DC-19 a-c
	15 of 19	60.6-64.7			PITT-10 DC-20 a-d
	16 of 19	64.7-69.0			PITT-10 DC-21 a-d
	17 of 19	69.0-73.4			PITT-10 DC-22 a-g
	18 of 19	73.4-77.2			PITT-10 DC-23 a-e
	19 of 19	77.2-81.5			PITT-10 DC-24 a-d
PM-WES-L-13-82	1 of 1	0.0- 2.0	798.1		PITT-10 CON-47 a,b
PM-WES-L-14-82	1 of 1	0.0- 1.6	792.1		PITT-10 CON-48 a-e
PM-WES-L-15-82	1 of 1	0.0- 3.2	798.0		PITT-10 CON-49 a,b
PM-WES-L-16-82	1 of 1	0.0- 3.2	792.0		PITT-10 CON-50 a,b
PM-WES-L-17-82	1 of 2 2 of 2	0.0- 4.4 4.4- 8.4	803.1	794.7	PITT-10 CON-51 a-e PITT-10 CON-52 a-c
PM-WES-L-18-82	1 of 1	0.0- 7.0	803.1	796.1	PITT-10 CON-53 a-e
PM-WES-Ga-1-82	1 of 1	0.0- 3.0	799.0		PITT-10 CON-54 a,b
PM-WES-Ga-2-82	1 of 1	0.0- 3.1	799.2		PITT-10 CON-55 a-c
PM-WES-Ga-3-82	1 of 1	0.0- 3.0	783.5		PITT-10 CON-56 a-d
PM-WES-Gi-1-82	1 of 1	0.0- 3.0	784.0		PITT-10 CON-57 a,b
PM-WES-Gi-2-82	1 of 1	0.0- 3.0	799.8		PITT-10 CON-58 a,b
PM-WES-Gi-3-82	1 of 1	0.0- 3.0	783.5		PITT-10 CON-59 a-d
PM-WES-Gi-4-82	1 of 1	0.0- 2.9	783.5		PITT-10 CON-60 a-d
PM-WES-Gi-5-82	1 of 1	0.0- 3.1	782.5		PITT-10 CON-61 a,b
PM-WES-L-19-82	1 of 3 2 of 3 3 of 3	0.0- 3.45 3.45-7.80 7.80-12.3	801.0	788.8	PITT-10 CON-62

Table 4

## Lock and Dam No. 8

## Summary Direct Shear Test Results

Rock Type and Test Type	Boring No. PM WES	Depth, ft	Normal Stress, tsf	Peak Shear Stress, tsf	Peak Shear Strength	Residual Shear Stress, tsf	Residual Shear Strength
Indurated clay, soft to mod. hard, gray/INTACT	L-10-82	67.50-67.90	1.8	8.0	$\phi = 35^\circ$	1.1	$\phi = 12^\circ$
	L-12-82	54.57-55.00	3.6	9.1	$c = 6.7$ tsf	2.4	$c = 1.1$ tsf
	L-10-82	72.22-72.50	7.2	11.7		2.4	
Indurated clay, hard gray/PRECUIT, concrete on rock	L-12-82	47.95-48.45	1.8	3.7	$\phi = 46^\circ$	1.2	$\phi = 14^\circ$
	L-10-82	56.10-56.52	3.6	5.1	$c = 1.6$	1.9	$c = 0.9$ tsf
	L-10-82	60.38-60.80	7.2	9.3		2.6	
Indurated clay, soft to mod. hard, gray/CONCRETE BONDED TO ROCK	L-10-82	46.23-46.45	1.8	0.8	$\phi = 18^\circ$	0.7	-
	L-10-82	59.07-59.30	3.6	1.2	$c = 0$	0.8	-
	L-10-82	61.15-61.32	7.2	2.5		1.9	
Indurated clay, soft to mod. hard, gray/CONCRETE BONDED TO ROCK	L-1-82	49.28-49.50	1.8	17.5	$\phi = 53^\circ$	1.4	$\phi = 21^\circ$
	L-1-82	49.50-49.70	3.6	24.4	$c = 16.9$ tsf	3.4	$c = 1.5$ tsf
	L-1-82	48.85-49.04	7.2	25.7		6.4	
Indurated clay, soft to mod. hard, gray/CONCRETE BONDED TO ROCK	L-1-82	46.40-46.63	1.8	11.2	$\phi = 55^\circ$	2.2	$\phi = 21^\circ$
	L-10-82	45.95-46.15	3.6	12.8	$c = 8.2$ tsf	2.9	$c = 1.5$ tsf
	L-1-82	46.70-46.90	7.2	18.8		4.3	
Indurated clay, soft to mod. hard, gray/CONCRETE BONDED TO ROCK	L-1-82	49.04-49.27	1.8	23.8	-	1.2	-
	L-10-82	49.53-49.76	3.6	5.4	-	3.0	-
	L-10-82	49.76-50.00	7.2	10.7	-	2.4	-

Table 5

## Concrete Core Test Results, Lock No. 8, Mon River

Boring No. PM-WES	Elev Top of Boring	Depth of Core ft	Characterization Properties			Engineering Design Property		
			Unit Weight pcf	Comp Wave Velocity fps	Comp Strength psi	Elastic Modulus psi X 10 <sup>6</sup>	Poisson's Ratio	
L-1-82	800.9	1.7- 2.7	146.6	13,972	6270	3.60	0.17	
L-1-82	781.6	21.0-22.0	139.1	12,884	4450	2.55	0.16	
L-1-82	762.6	40.0-41.0	139.0	12,437	2690	2.09	0.15	
L-3-82	800.2	2.4- 3.4	138.4	12,478	5450			
L-3-82	795.2	7.4- 8.4	139.0	12,187	4850			
L-4-82	784.0	0.5- 1.5	140.1	12,109	5300	2.50	0.22	
L-7-82	798.7	3.9- 4.9	144.7		6400			
L-7-82	794.7	7.9- 8.9	141.3	12,521	5350			
L-8-82	784.0	1.2- 1.6	138.2	11,351	--			
L-8-82	784.0	2.5- 3.4	139.0	12,487	4200	2.95	0.16	
L-9-82	784.0	0.8- 1.8	139.2	11,785	5580	2.15	0.15	
L-9-82	784.0	1.8- 2.8	142.0	12,850	5800	2.65	0.17	
L-10-82	801.6	1.0- 2.0	146.1	10,042	3860	1.75	0.10	
L-10-82	782.9	19.7-20.7	143.9	13,175	3480	2.53	0.10	
L-10-82	765.2	37.4-38.4	140.3	13,064	4030	2.85	0.14	
L-12-82	799.5	3.1- 4.1	140.3	12,525	5200	2.37	0.10	
L-12-82	782.6	20.0-21.0	134.1	12,108	2950	1.70	0.11	
L-12-82	763.6	39.0-40.0	143.0	12,734	3610	2.33	0.12	
L-13-82	798.1	1.0- 2.0	141.2	12,057	3350	1.75	0.13	
L-15-82	798.0	1.0- 2.0	144.2	11,240	4840	2.40	0.11	
L-15-82	798.0	2.0- 3.0	144.2	13,459	4820	2.80	0.14	
L-16-82	792.0	0.7- 1.7	143.1	12,617	5400	1.96	0.12	
L-17-82	800.7	2.0- 2.8	145.7	12,487	7000	2.65	0.12	
L-17-82	795.3	7.3- 8.3	142.1	12,982	6200	2.15	0.16	
Ga-1-82	799.0	0.1- 1.1	145.0	--	7770			
Ga-3-82	783.5	0.4- 1.4	140.4	--	5610			
Gi-1-82	784.0	0.8- 1.8	139.5	12,202	3820			
Gi-2-82	784.0	1.8- 2.8	140.3	--	4410	2.10	0.07	
Gi-3-82	783.5	0.4- 1.0	143.2	--	4240			
Gi-4-82	783.5	1.1- 1.8	138.3	--	4540			
Gi-5-82	782.5	1.6- 2.6	142.6	--	4730			

1002

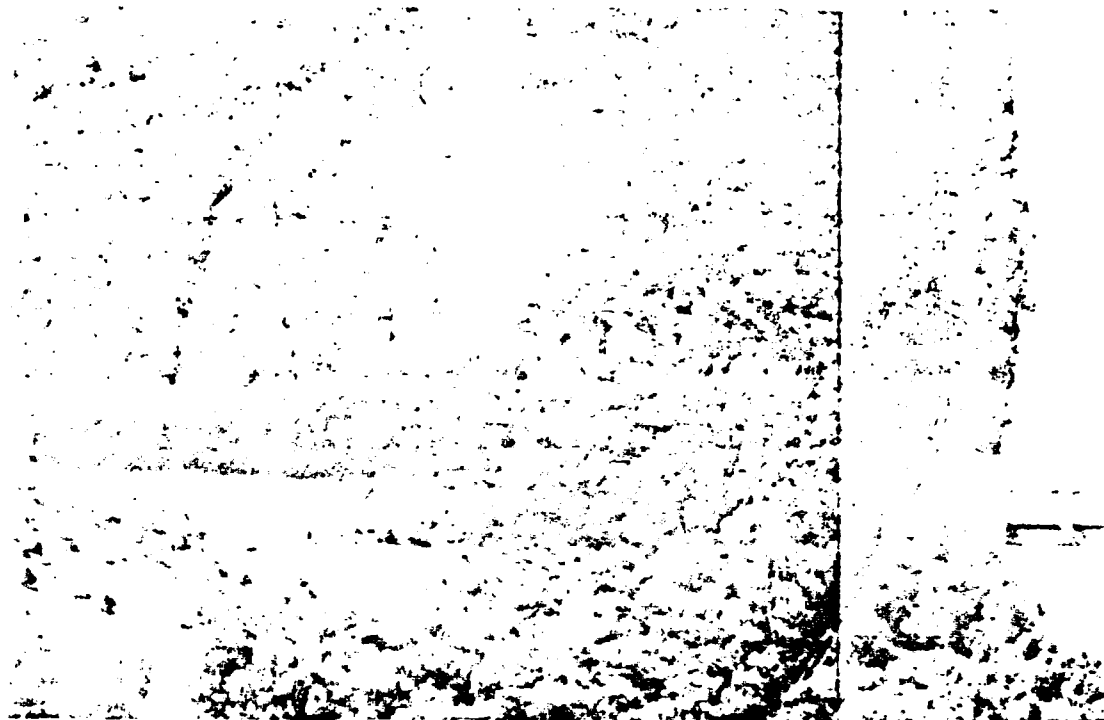

27 AUG. 1963

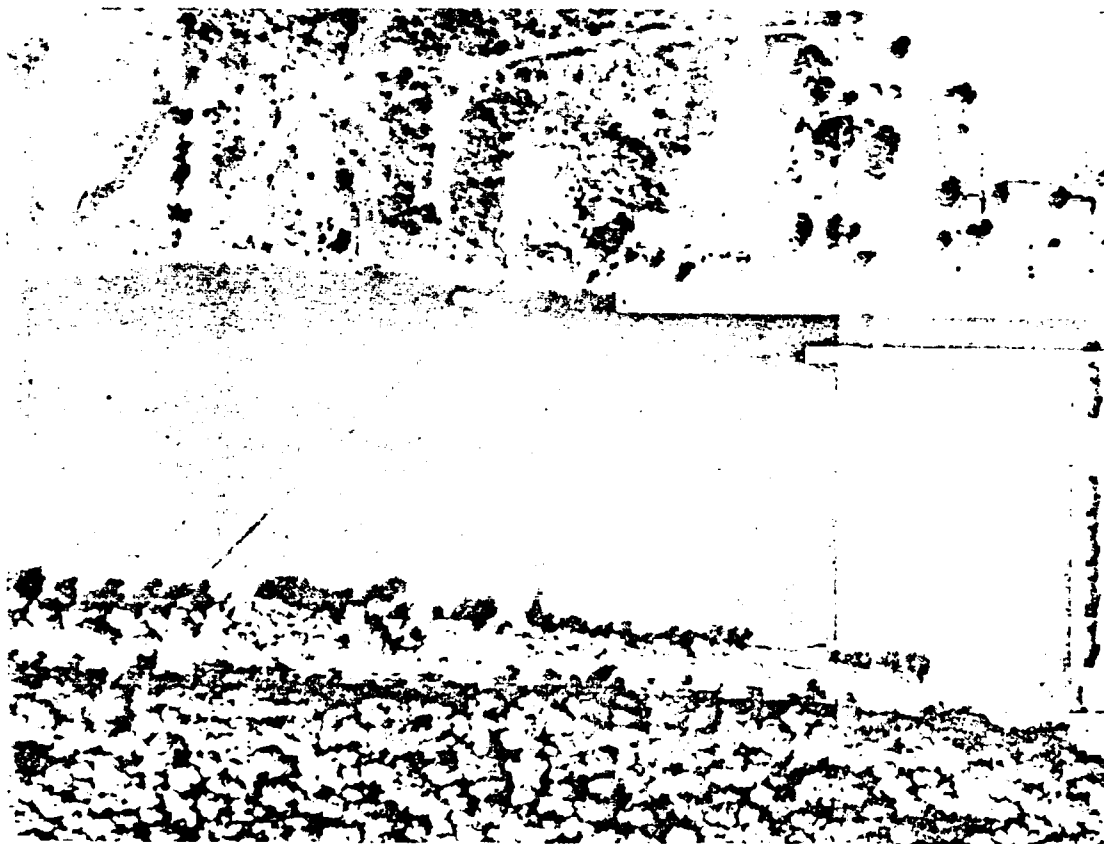

26 AUG. 1963

R/H 20  
LOCK & DAM 8  
MONONGAHELA RIVER

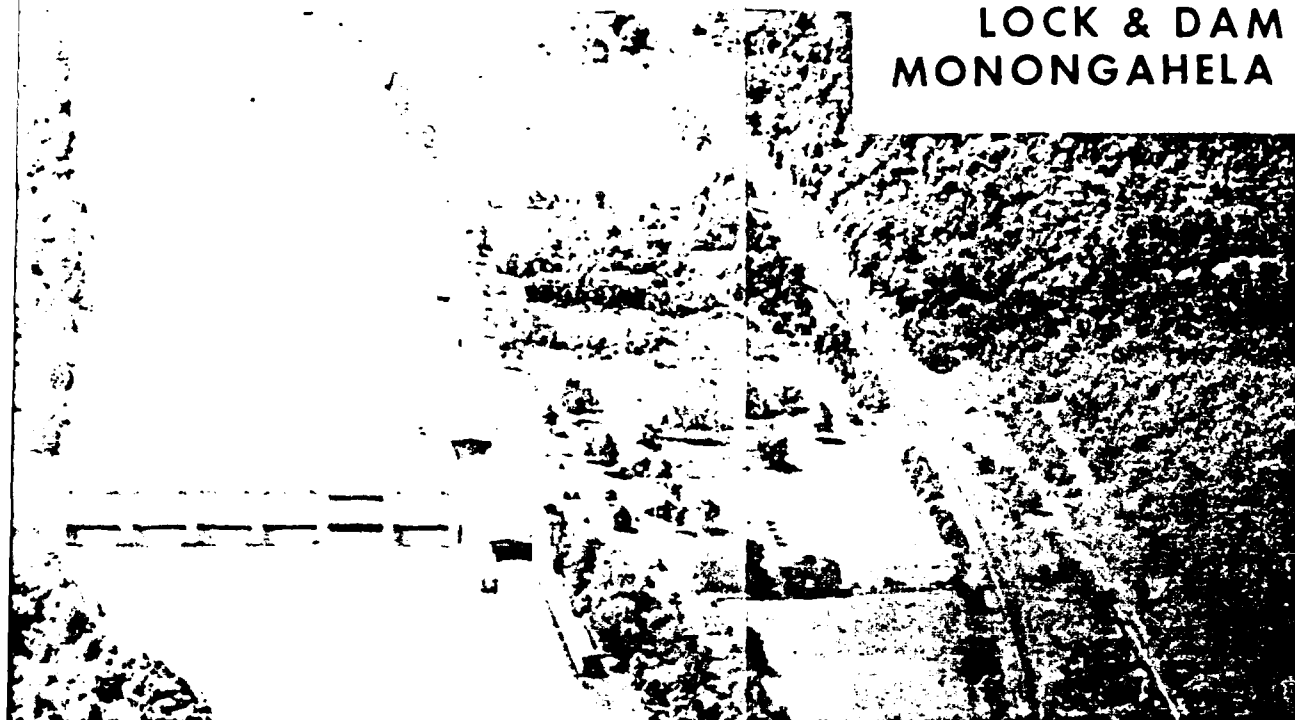

27

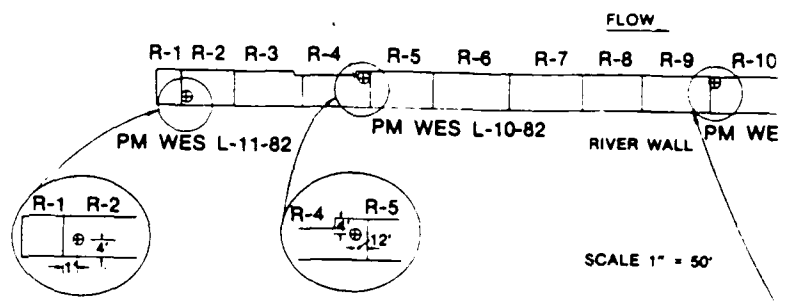
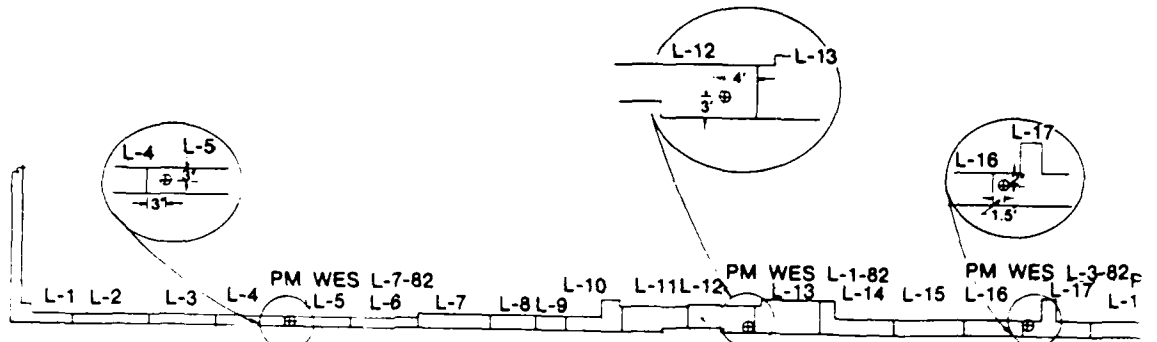

SCALE 1" = 50'

PLAN

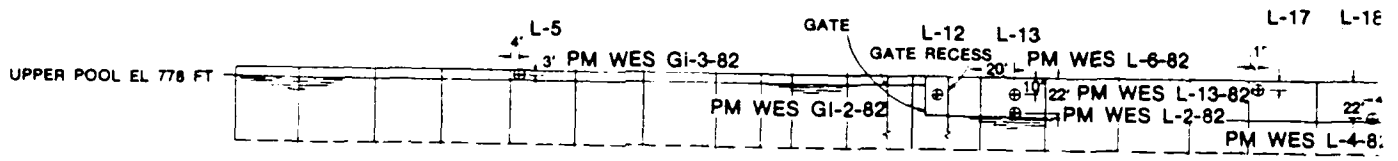

ELEVATION LAND WAL

SCALE 1" = 50'

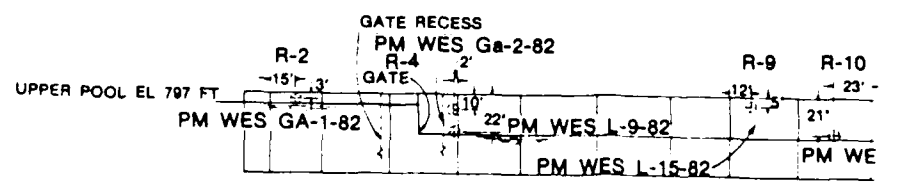

ELEVATION RIVER WAL

SCALE 1" = 50'

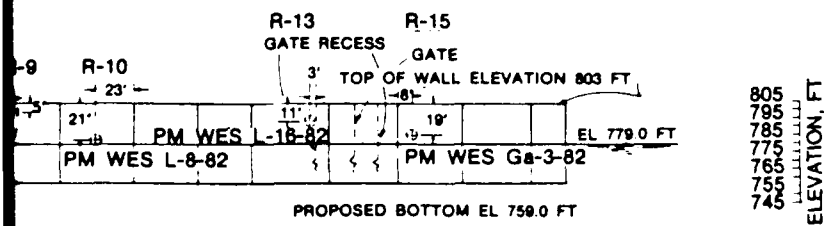
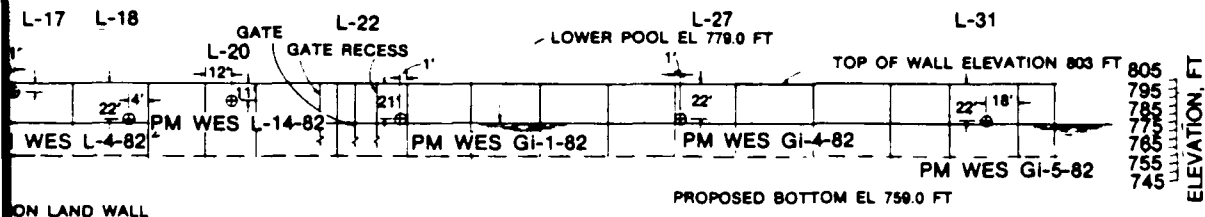
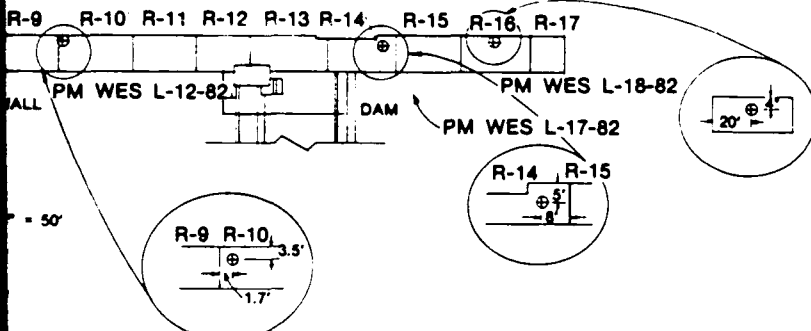
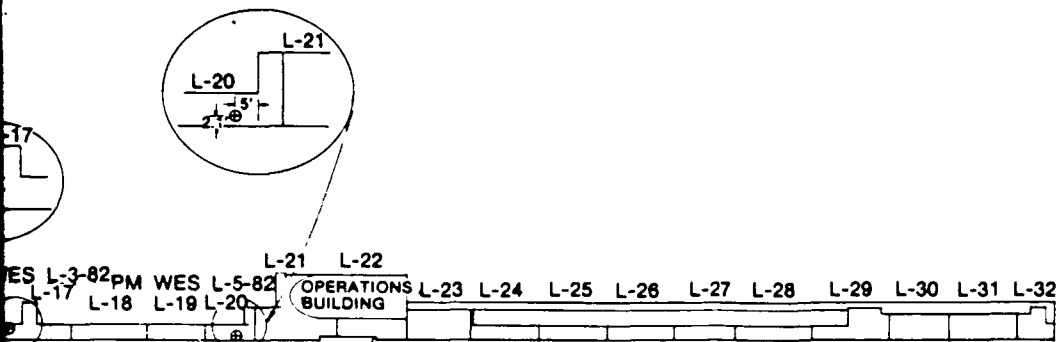

CONDITION SURVEY  
 AUGUST 1982  
 LOCK AND DAM 8  
 MONONGAHELA RIVER  
 BORING LOCATION PLAN

DRAWN BY R. L. STOWE  
 DATE 8/28/82  
 REVISED 1/14/83

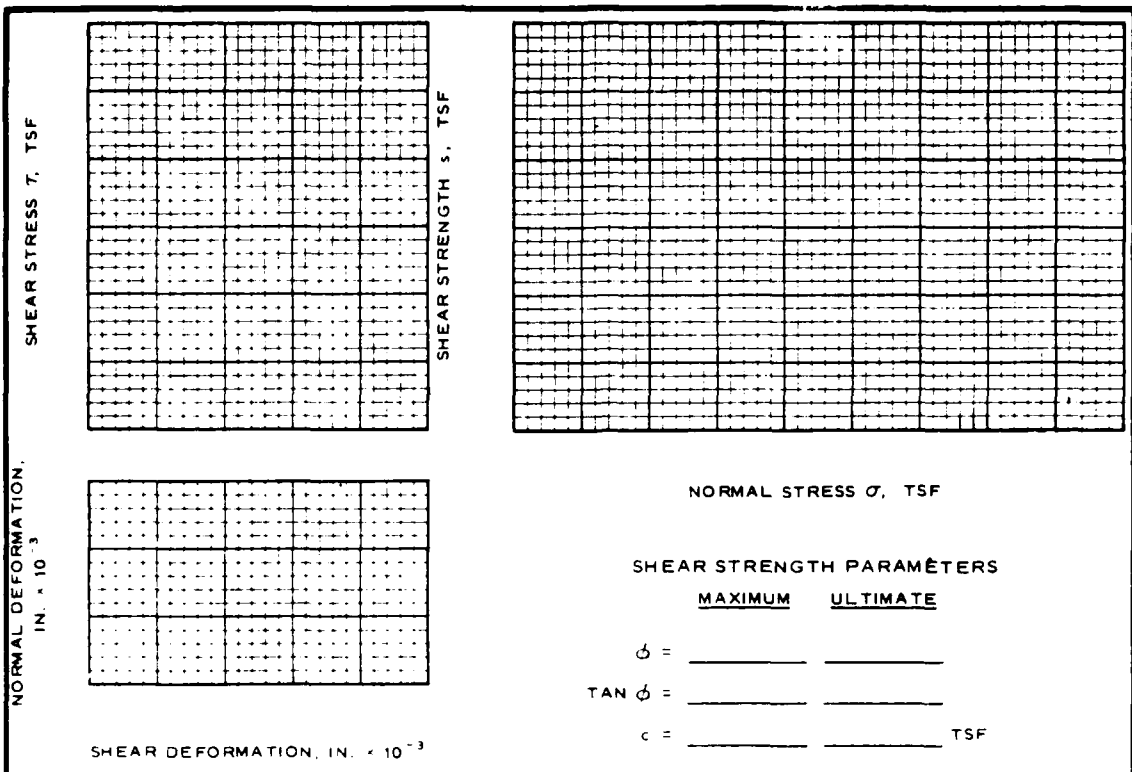

TEST NO.	Boring No. Depth, ft	L-12-82 47.95	L-12-82 54.57	L-10-82 72.22	L-10-82 67.50	L-10-82 56.10	L-10-82 60.38
WET DENSITY, PCF	$\gamma_s$	--	163.7	155.7	160.1	156.2	165.4
WATER CONTENT	w	5.2 %	3.0 %	5.27 %	3.5 %	6.8 %	3.3 %
NORMAL STRESS, TSF	$\sigma$	1.8	3.6	7.2	1.8	3.6	7.2
MAXIMUM SHEAR STRESS, TSF	$\tau_f$	3.7	9.1	11.7	8.0	5.1	9.3
TIME TO FAILURE, MINUTES	$t_f$	9	19	7	15	13	22
ULTIMATE SHEAR STRESS, TSF	$\tau_u$	1.2	2.4	2.4	1.1	1.9	2.6
NOMINAL DIAMETER, IN	$D_s$	5.9	5.9	5.8	5.9	5.9	6.0
NOMINAL HEIGHT, IN	$H_s$	6.0	5.3	3.4	4.7	5.1	5.1

TYPE OF MATERIAL: Indurated clay, soft, gray

REMARKS	PROJECT <u>Lock &amp; Dam 8, Mon River</u>
	INTACT
	AREA
	BORING NO. <u>See Test No.</u> SAMPLE NO.
	DEPTH <u>See Test No.</u> DATE <u>12-2, 1954</u>
DIRECT SHEAR TEST REPORT (ROCK)	

SHEAR STRESS  $\tau$ , TSF

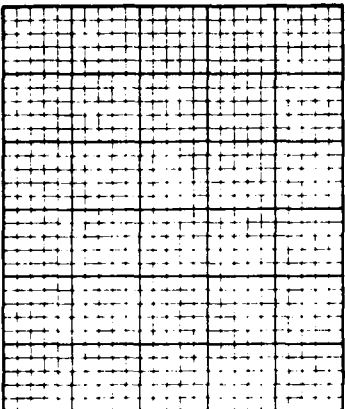

SHEAR STRENGTH  $s$ , TSF

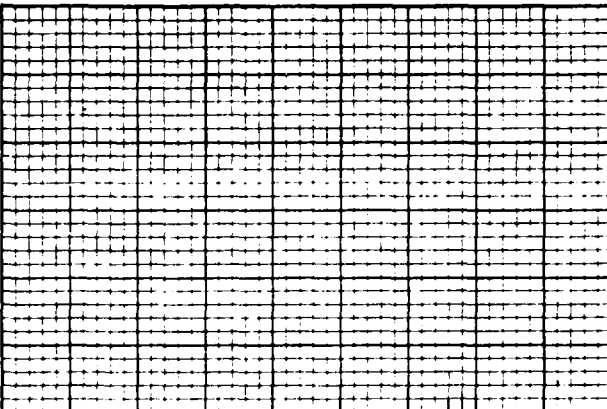

NORMAL DEFORMATION, IN.  $\times 10^{-3}$

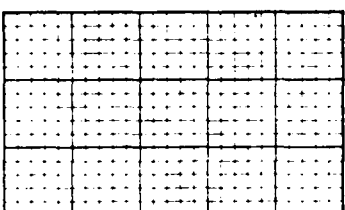

NORMAL STRESS  $\sigma$ , TSF

SHEAR STRENGTH PARAMETERS

MAXIMUM      ULTIMATE

$\phi$  = \_\_\_\_\_

TAN  $\phi$  = \_\_\_\_\_

$c$  = \_\_\_\_\_ TSF

SHEAR DEFORMATION, IN.  $\times 10^{-3}$

Boring No.		L-10-82	L-10-82	L-10-82			
TEST NO.	Depth, ft	46.2	59.1	61.2			
WET DENSITY, PCF	$\gamma_d$	168.3	164.9	159.2			
WATER CONTENT	$w$	1.8%	3.8%	3.4%			
NORMAL STRESS, TSF	$\sigma$	1.8	3.6	7.2			
MAXIMUM SHEAR STRESS, TSF	$\tau_f$	0.8	1.2	2.5			
TIME TO FAILURE, MINUTES	$t_f$	9	10	10			
ULTIMATE SHEAR STRESS, TSF	$\tau_u$	0.7	0.8	1.9			
INITIAL DIAMETER, IN.	$D_0$	5.9	5.9	5.9			
INITIAL HEIGHT, IN.	$H_0$	3.0/2.6	2.2/2.8	2.4/2.1			

DESCRIPTION OF MATERIAL Indurated clay, soft, gray

REMARKS			PROJECT Lock & Dam 8, Mon River			
			PRECUT, Concrete on Rock			
Concrete	L-1-82	39.4	AREA			
Rock	L-10-82	59.1	BORING NO.	L-10-82	SAMPLE NO.	
Rock	L-10-82	46.2	DEPTH	See Test No. DATE 12/20/82		
Rock	L-10-82	61.2	DIRECT SHEAR TEST REPORT (ROCK)			

SHEAR STRESS  $\tau$ , TSF

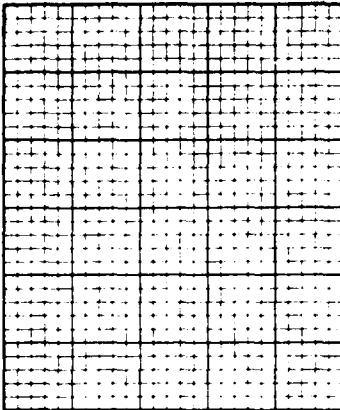

SHEAR STRENGTH  $s$ , TSF

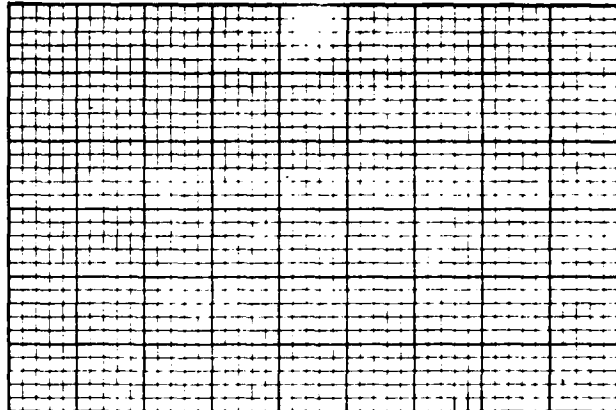

NORMAL DEFORMATION, IN.  $\times 10^{-3}$

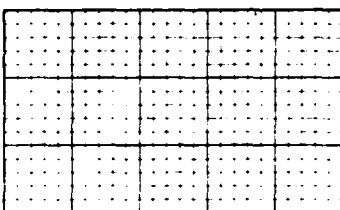

NORMAL STRESS  $\sigma$ , TSF

SHEAR STRENGTH PARAMETERS

MAXIMUM    ULTIMATE

$\phi$  = \_\_\_\_\_

TAN  $\phi$  = \_\_\_\_\_

$c$  = \_\_\_\_\_ TSF

SHEAR DEFORMATION, IN.  $\times 10^{-3}$

Boring No.		L-1-82	L-1-82	L-1-82	L-1-82	L-10-82	L-1-82
TEST NO.	Depth, ft	49.28	49.50	48.85	46.40	45.95	46.7
WET DENSITY, PCF	$\gamma_d$	165.1	169.3	168.3	170.4	165.5	166.7
WATER CONTENT	w	1.9	1.9	1.6	1.7	2.3	1.6
NORMAL STRESS, TSF	$\sigma$	1.8	3.6	7.2	1.8	3.6	7.2
MAXIMUM SHEAR STRESS, TSF	$\tau$	17.5	24.4	25.7	11.2	12.8	18.8
TIME TO FAILURE, MINUTES	$t_f$	31	27	32	5	5	25
ULTIMATE SHEAR STRESS, TSF	$\tau_u$	1.4	3.4	6.4	2.2	2.9	4.3
DIAL PARAMETER, IN.	$D_s$	5.9	5.9	5.9	5.9	5.9	5.9
DIAL HEIGHT, IN.	$H_s$	5.3	4.8	4.7	5.5	4.5	4.0

TYPE OF MATERIAL: Indurated clay, moderately hard

REMARKS	PROJECT: <u>Lock &amp; Dam 3, Moh River</u>
	CONCRETE BONDED TO ROCK
	AREA
	BORING NO. <u>See Test No.</u> SAMPLE NO.
	DEPTH <u>See Test No.</u> DATE <u>1-11-55</u>
	DIRECT SHEAR TEST REPORT (ROCK)

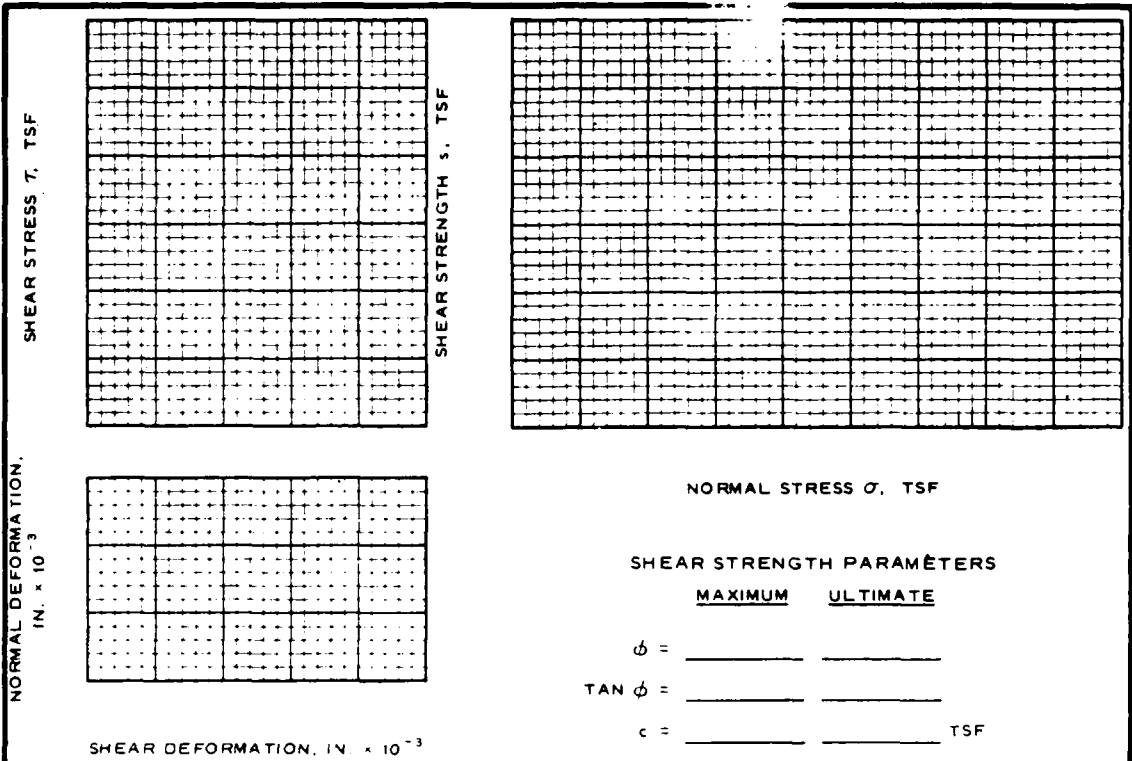

TEST NO.	Boring No. Depth, ft	L-1-82 49.04	L-10-82 49.53	L-10-82 49.76			
WET DENSITY, PCF	$\gamma_d$	167.3	167.3	166.1			
WATER CONTENT	$w$	1.6 %	1.6 %	2.1 %			
NORMAL STRESS, TSF	$\sigma$	1.8	3.6	7.2			
MAXIMUM SHEAR STRESS, TSF	$\tau_f$	23.8	5.4	10.7			
TIME TO FAILURE, MINUTES	$t_f$	27	--	--			
ULTIMATE SHEAR STRESS, TSF	$\tau_u$	1.2	3.0	2.4			
INITIAL DIAMETER, IN.	$D_0$	5.9	5.9	5.9			
INITIAL HEIGHT, IN.	$H_0$	5.3	5.3	6.1			

DESCRIPTION OF MATERIAL Indurated clay, soft to moderately hard

REMARKS	PROJECT <u>Lock &amp; Dam 8, Mon River</u>	
	CONCRETE BONDED TO ROCK	
	AREA	
	BORING NO. <u>See Test No.</u>	SAMPLE NO.
	DEPTH <u>See Test No.</u>	DATE <u>1-7-83</u>
DIRECT SHEAR TEST REPORT (ROCK)		

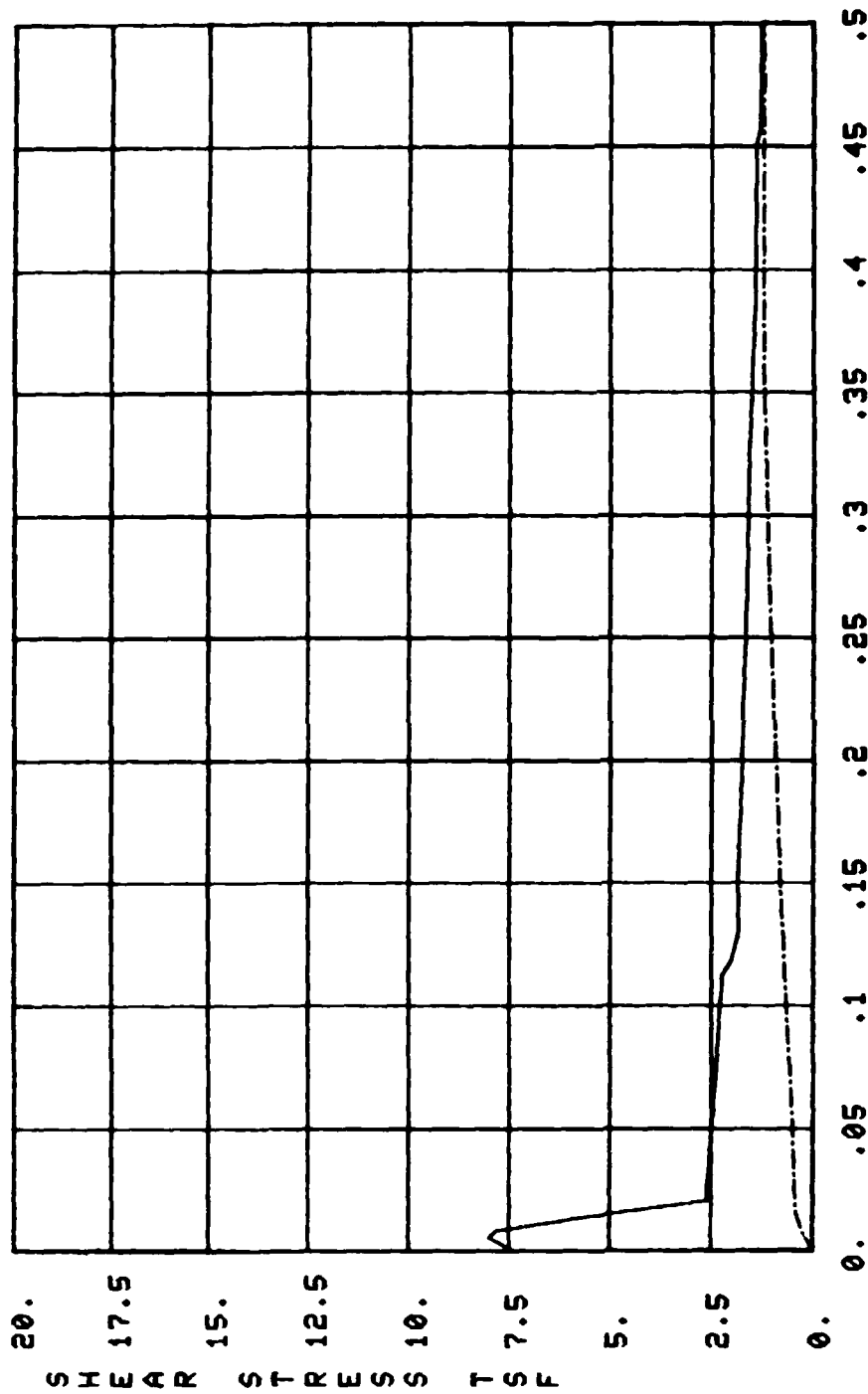

SHEAR DEFORMATION, IN

— MAXIMUM  
- - - ULTIMATE

DIRECT SHEAR-INTACT, INDURATED CLAY  
L-10-82, 67.50-67.90 FT, NL 1.8 TSF  
LOCK AND DAM #8 MON RIVER

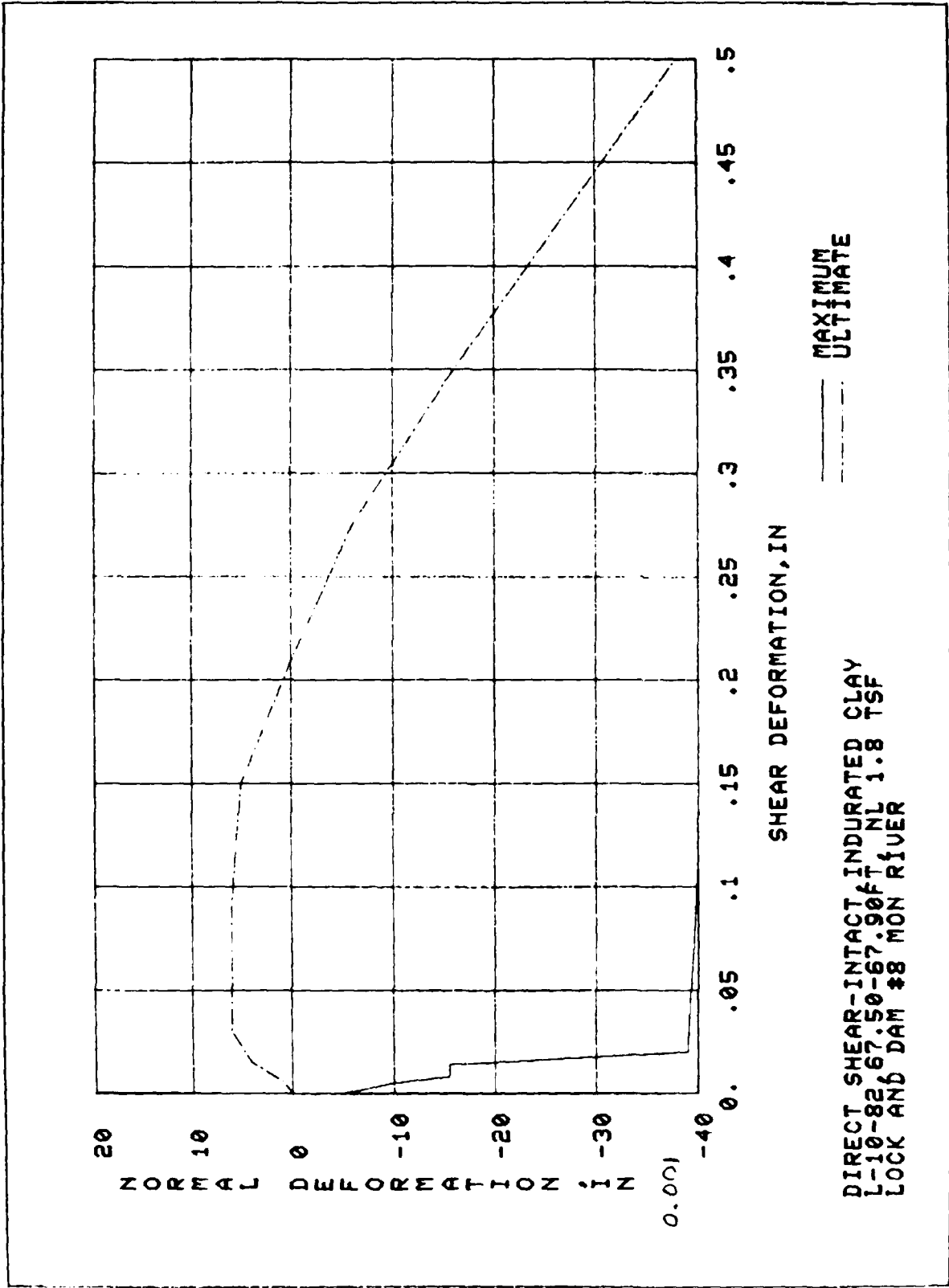
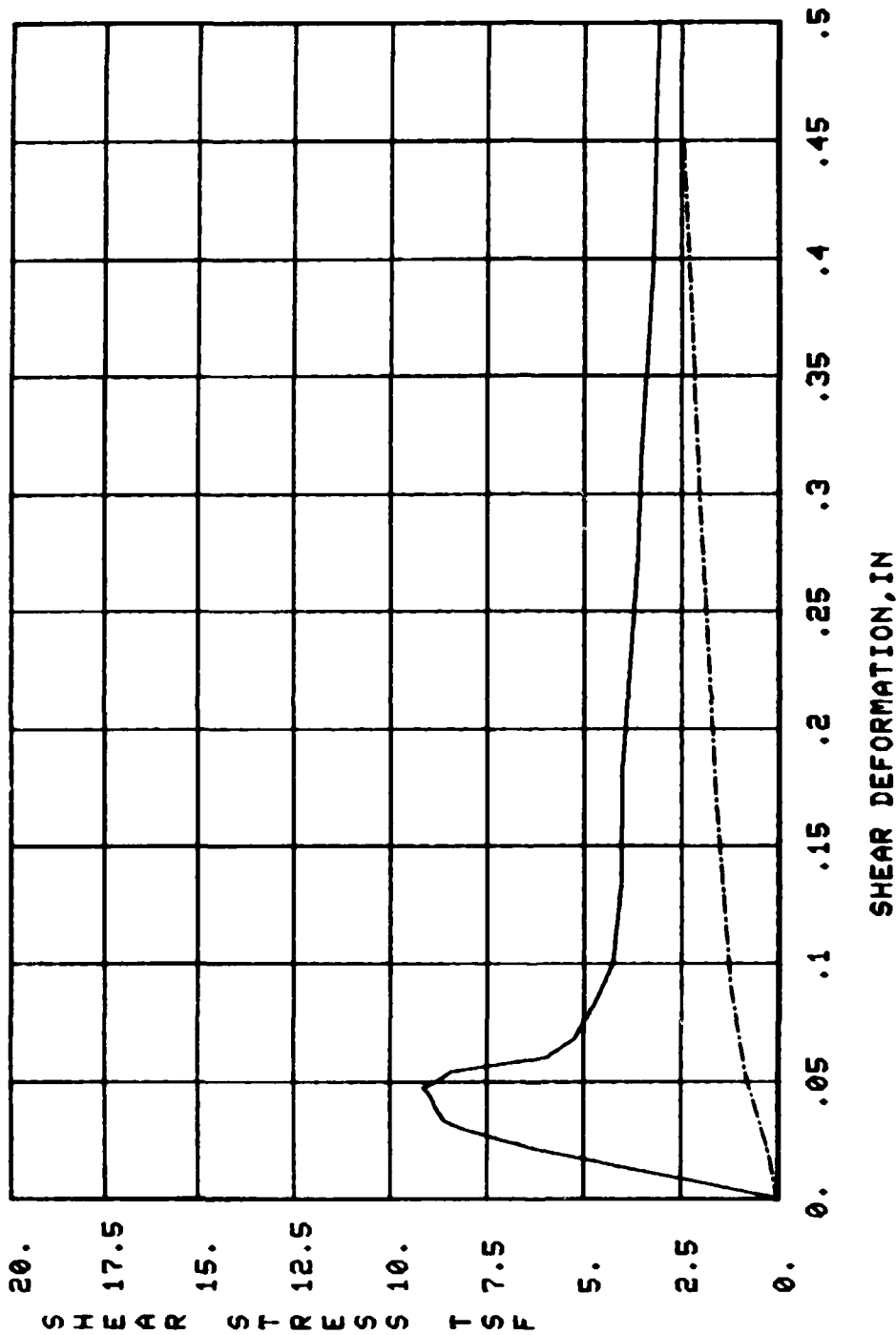
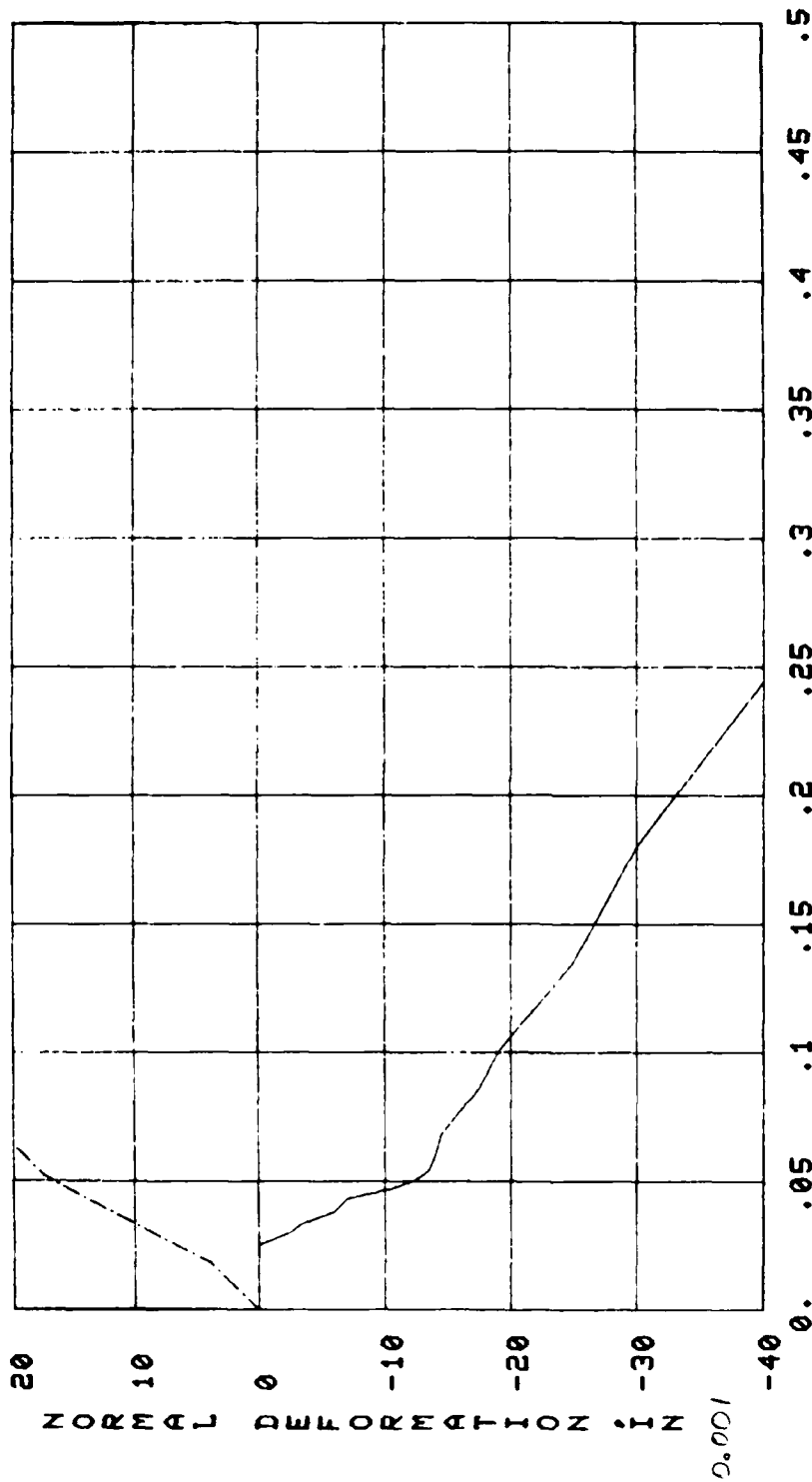

PLATE 8



DIRECT SHEAR-INTACT, INDURATED CLAY  
 L-12-82, 54.67-55.00 FT, NL3.6 TSF  
 LOCK AND DAM #8 MON RIVER



SHEAR DEFORMATION, IN

MAXIMUM  
ULTIMATE

DIRECT SHEAR-INTACT, INDURATED CLAY  
L-12-82, 54.57-55.00 FT, NL3.6 TSF  
LOCK AND DAM #8 MON RIVER

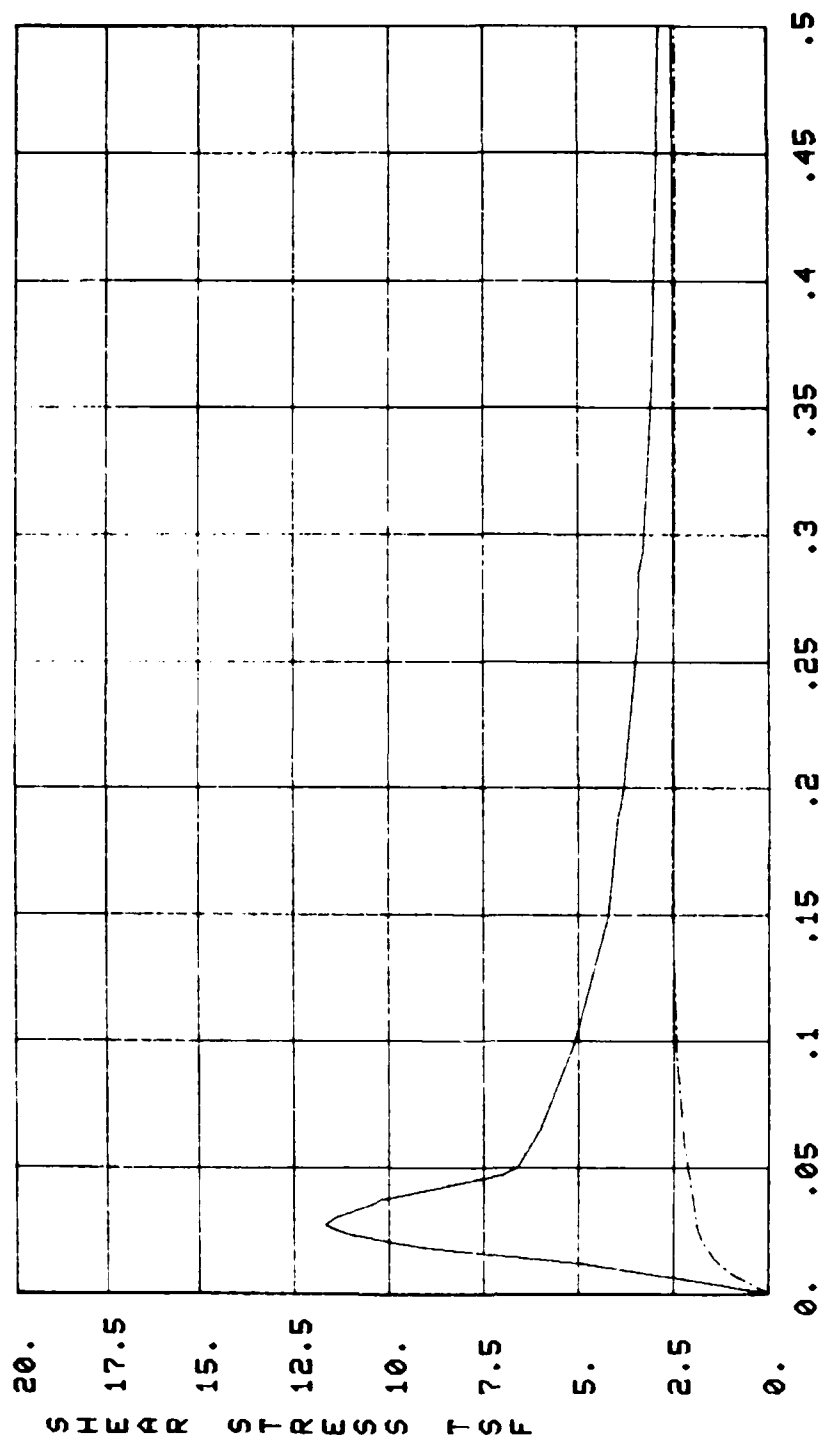

SHEAR DEFORMATION, IN

MAXIMUM  
ULTIMATE

DIRECT SHEAR-INTACT INDURATED CLAY  
L-10-82, 72.22-72.50 FT, NL7.2 TSF  
LOCK AND DAM #8 MON RIVER

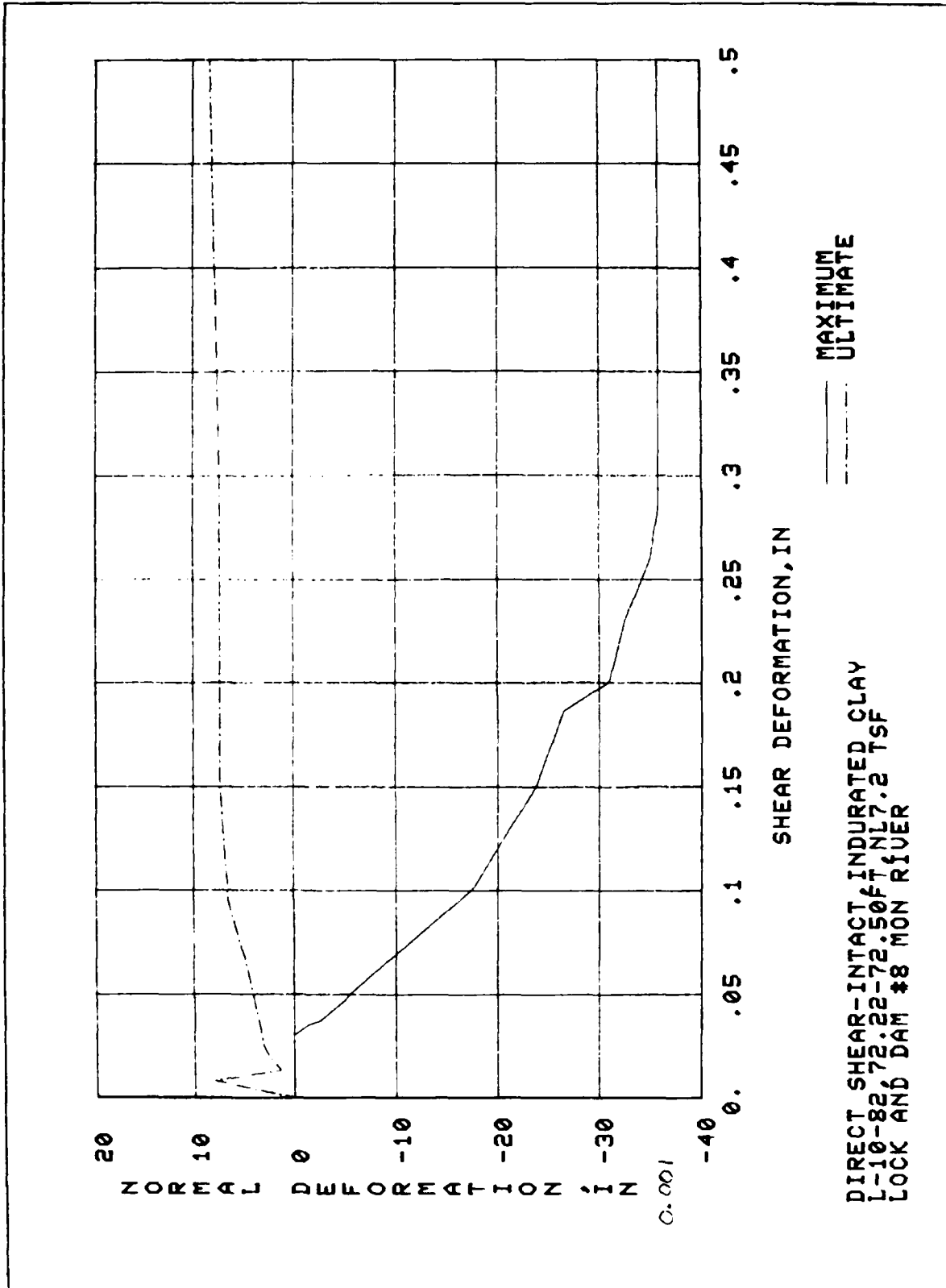
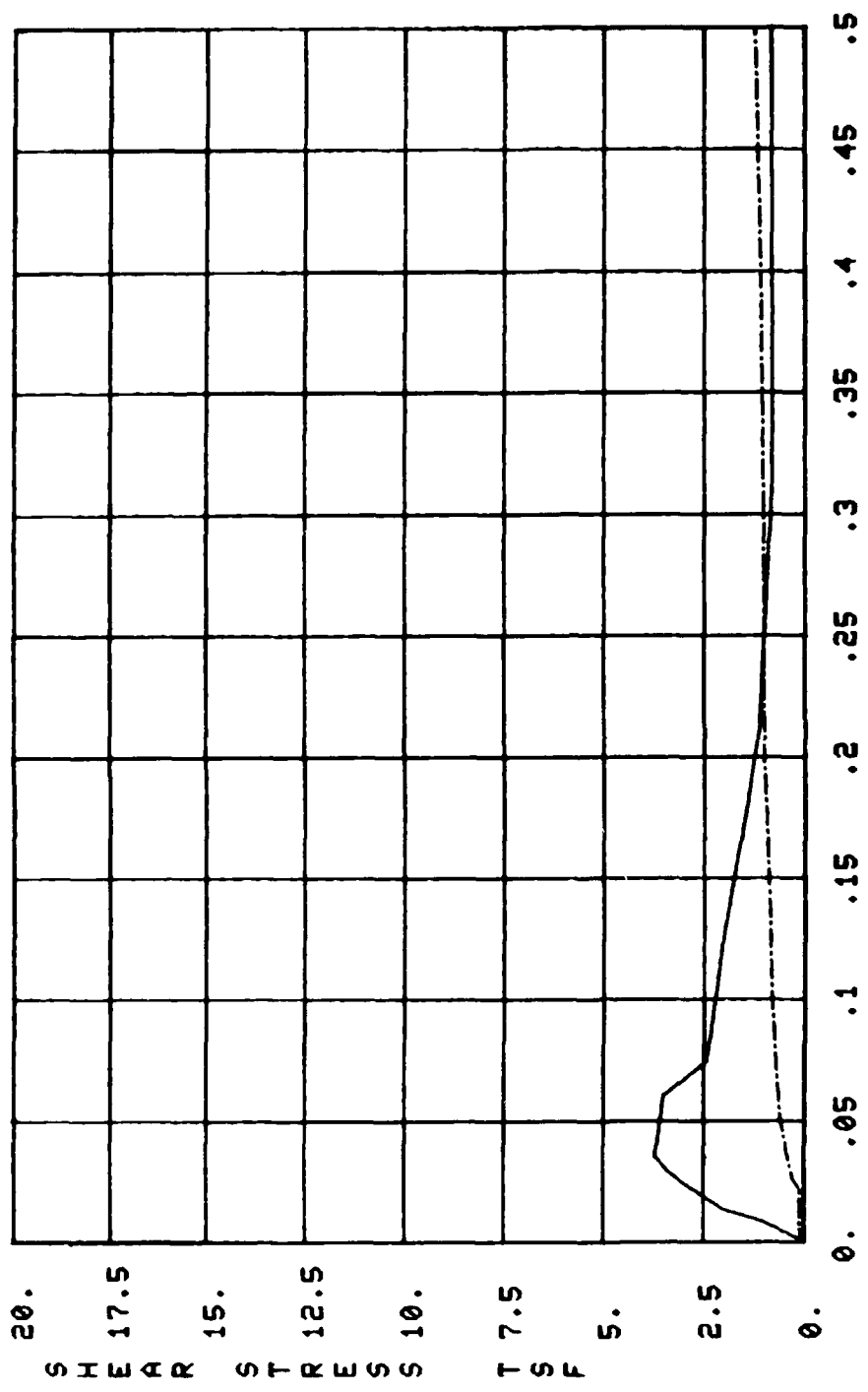

PLATE 12



SHEAR DEFORMATION, IN

MAXIMUM  
ULTIMATE

DIRECT SHEAR-INTACT, INDURATED CLAY  
L-12-82, 47.95-48.45 FT, NL1.8TSF  
LOCK AND DAM #8 MON RIVER

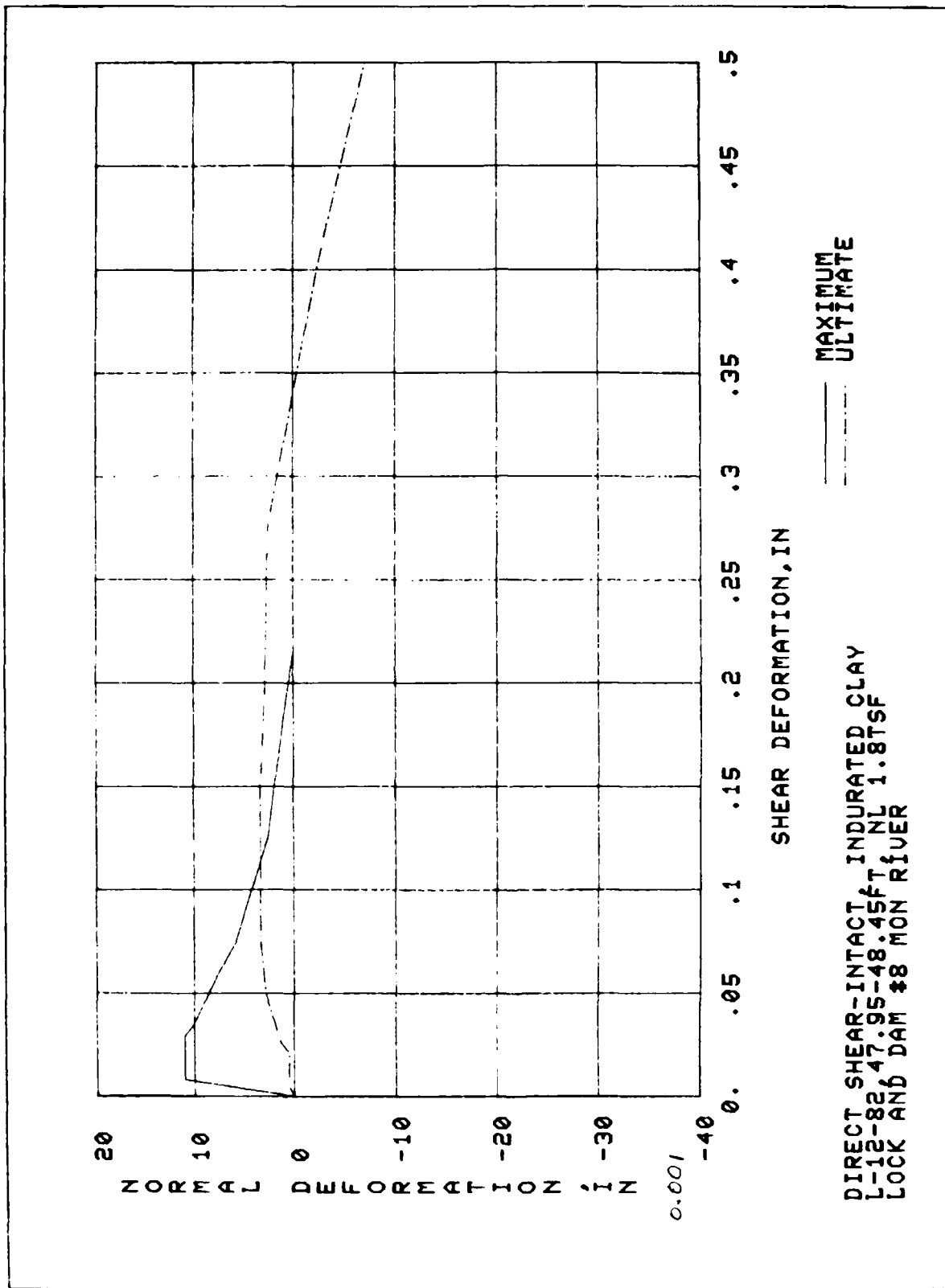
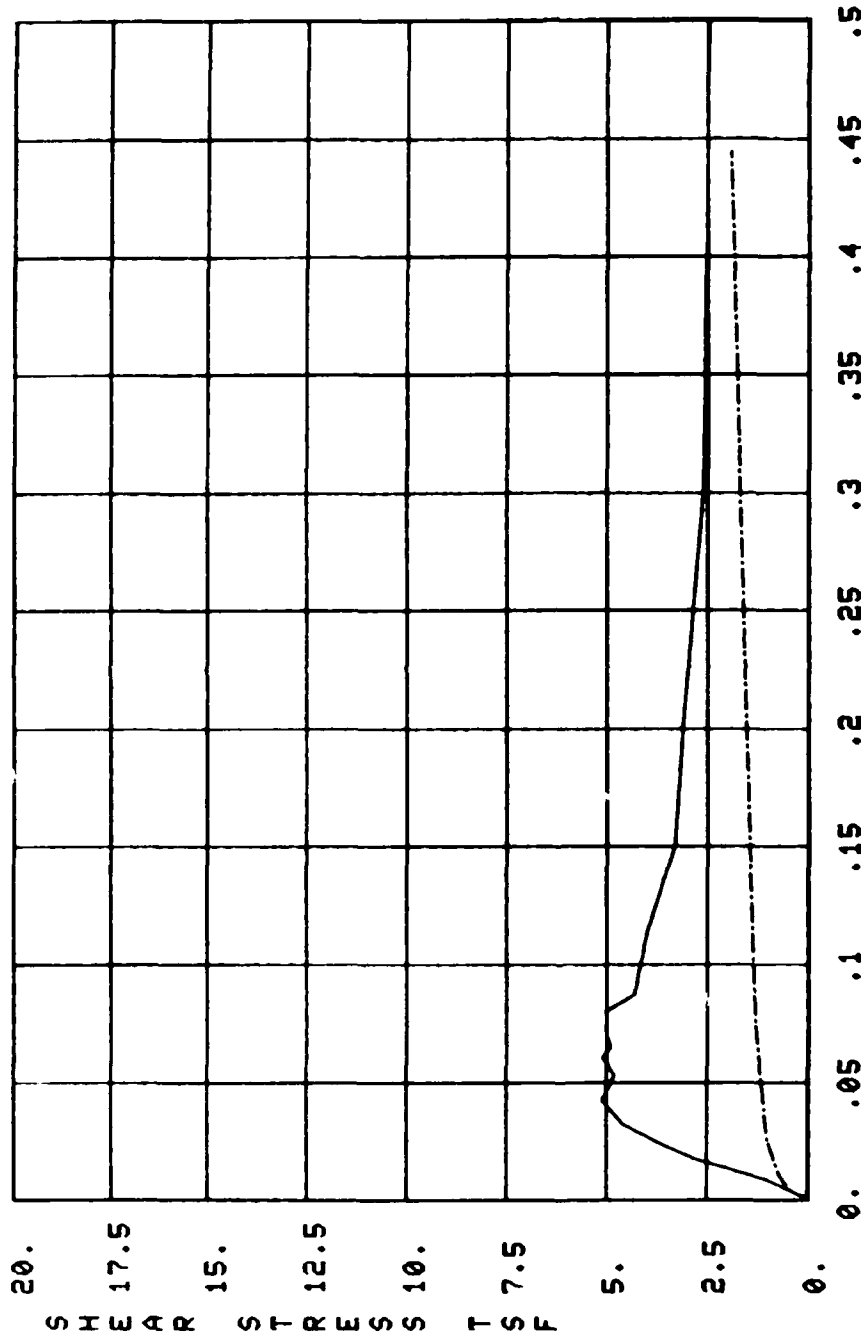

PLATE 14



SHEAR DEFORMATION, IN

— MAXIMUM  
- - - ULTIMATE

DIRECT SHEAR-INTACT, INDURATED CLAY  
L-10-82, 56.10-56.52 FT, NL 3.6 TSF  
LOCK AND DAM #8 MON RIVER

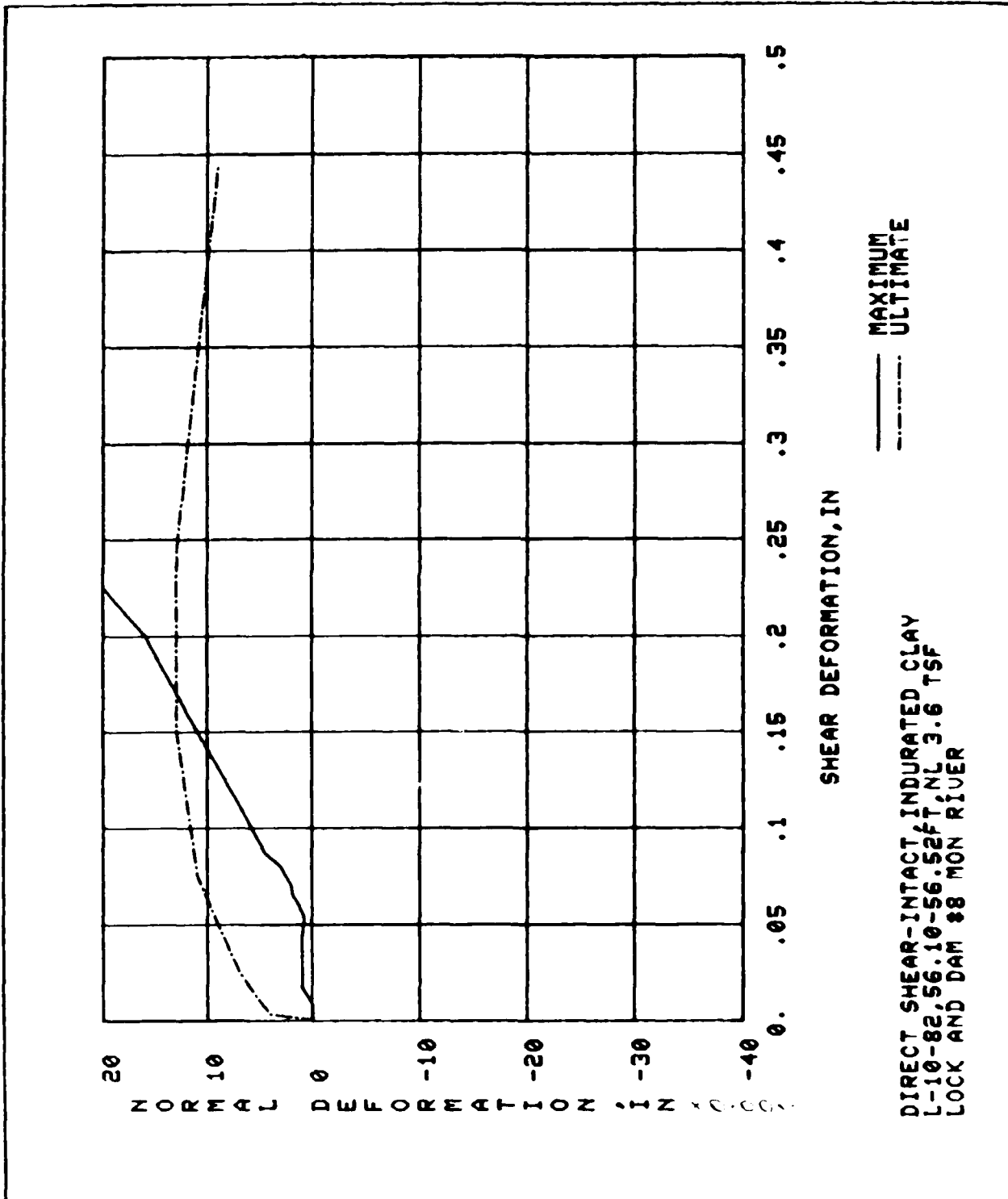
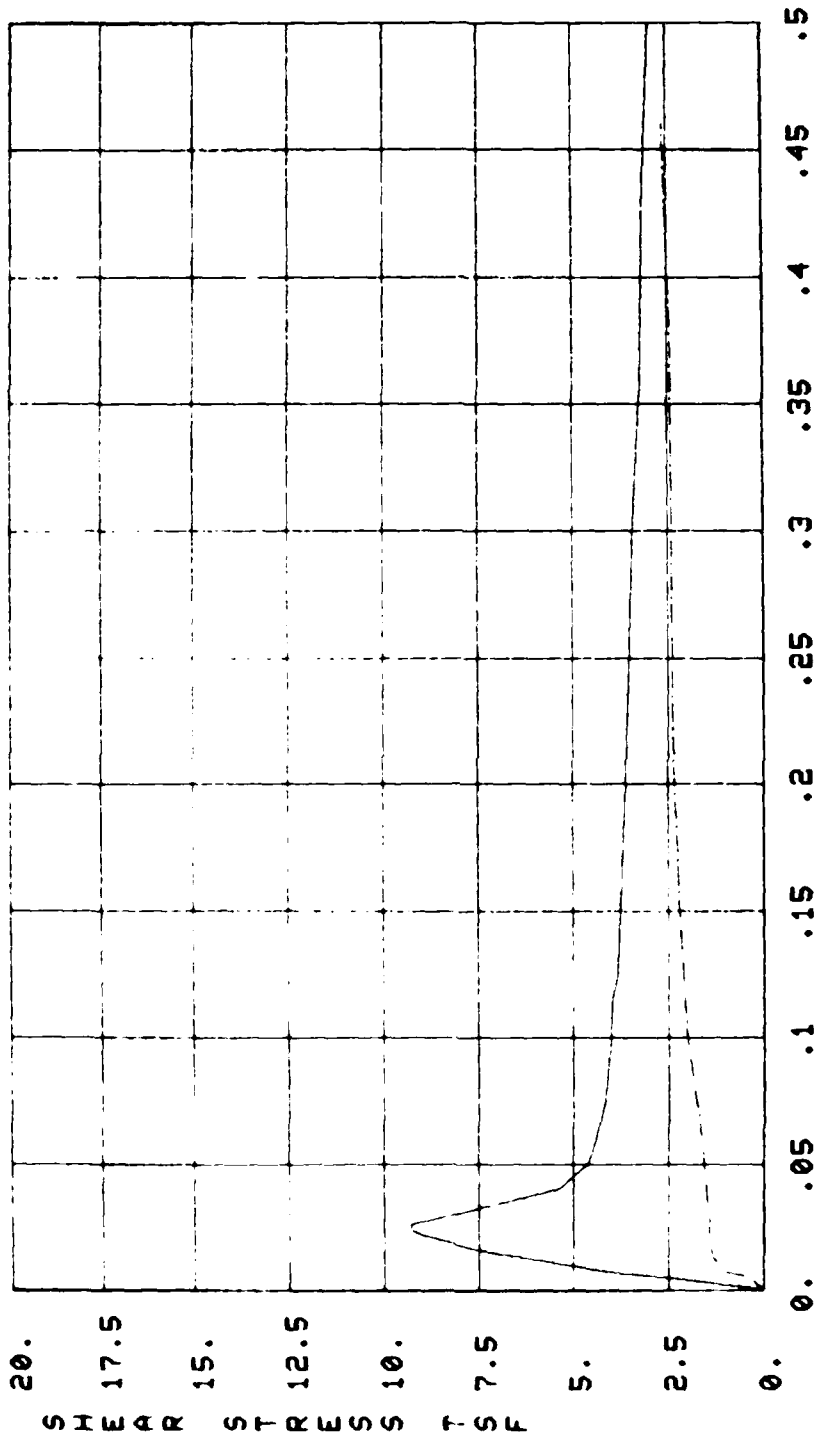

PLATE 16



SHEAR DEFORMATION, IN

MAXIMUM  
ULTIMATE

DIRECT SHEAR-INTACT, INDURATED CLAY  
L-10-82, 60:38-60:80, NL7.2 TSF  
LOCK AND DAM #8 MON RIVER

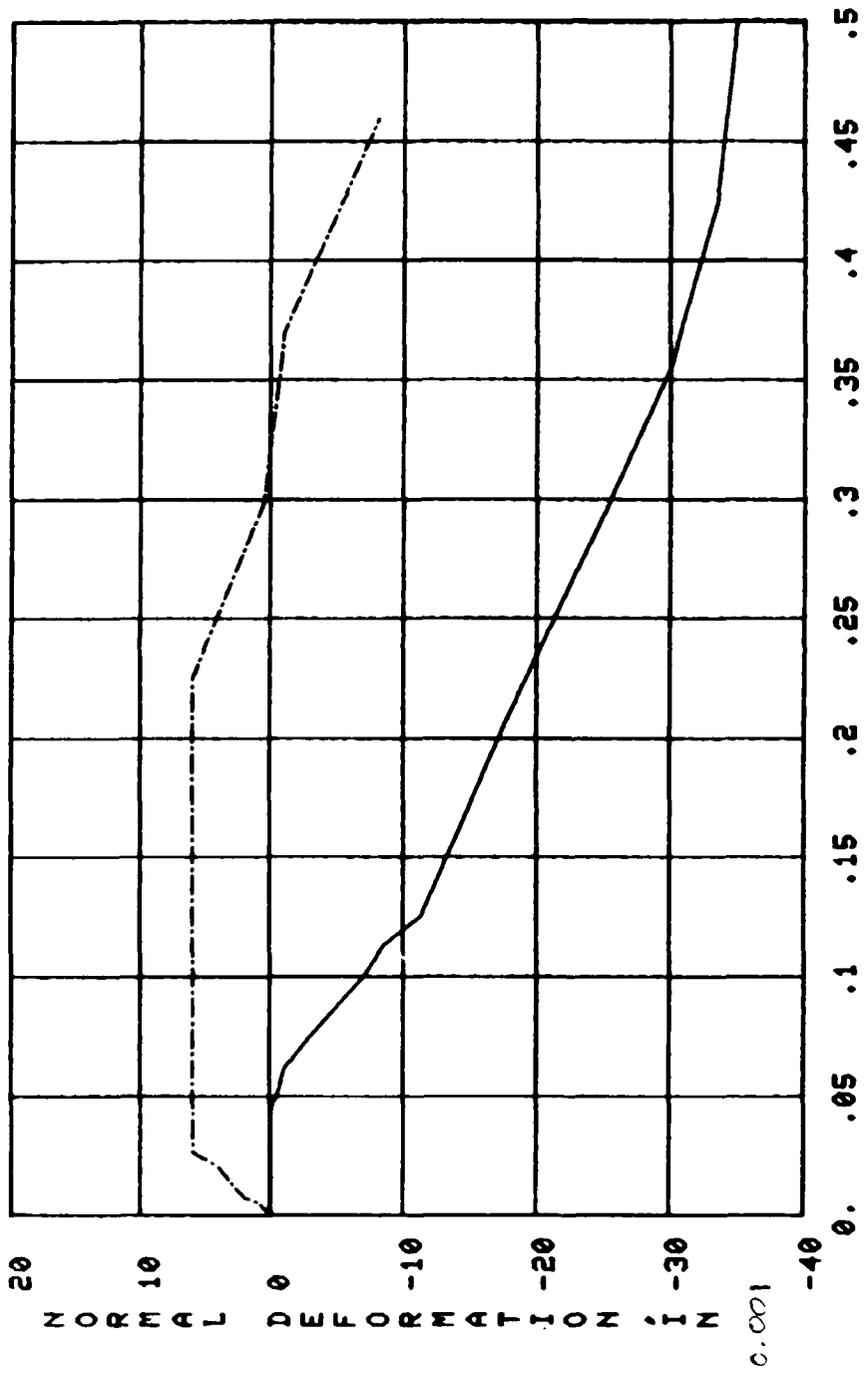

SHEAR DEFORMATION, IN

MAXIMUM  
 ULTIMATE

DIRECT SHEAR-INTACT, INDURATED CLAY  
 L-10-82, 60.38-60.80, NL7.2 TSF  
 LOCK AND DAM #8 MON RIVER

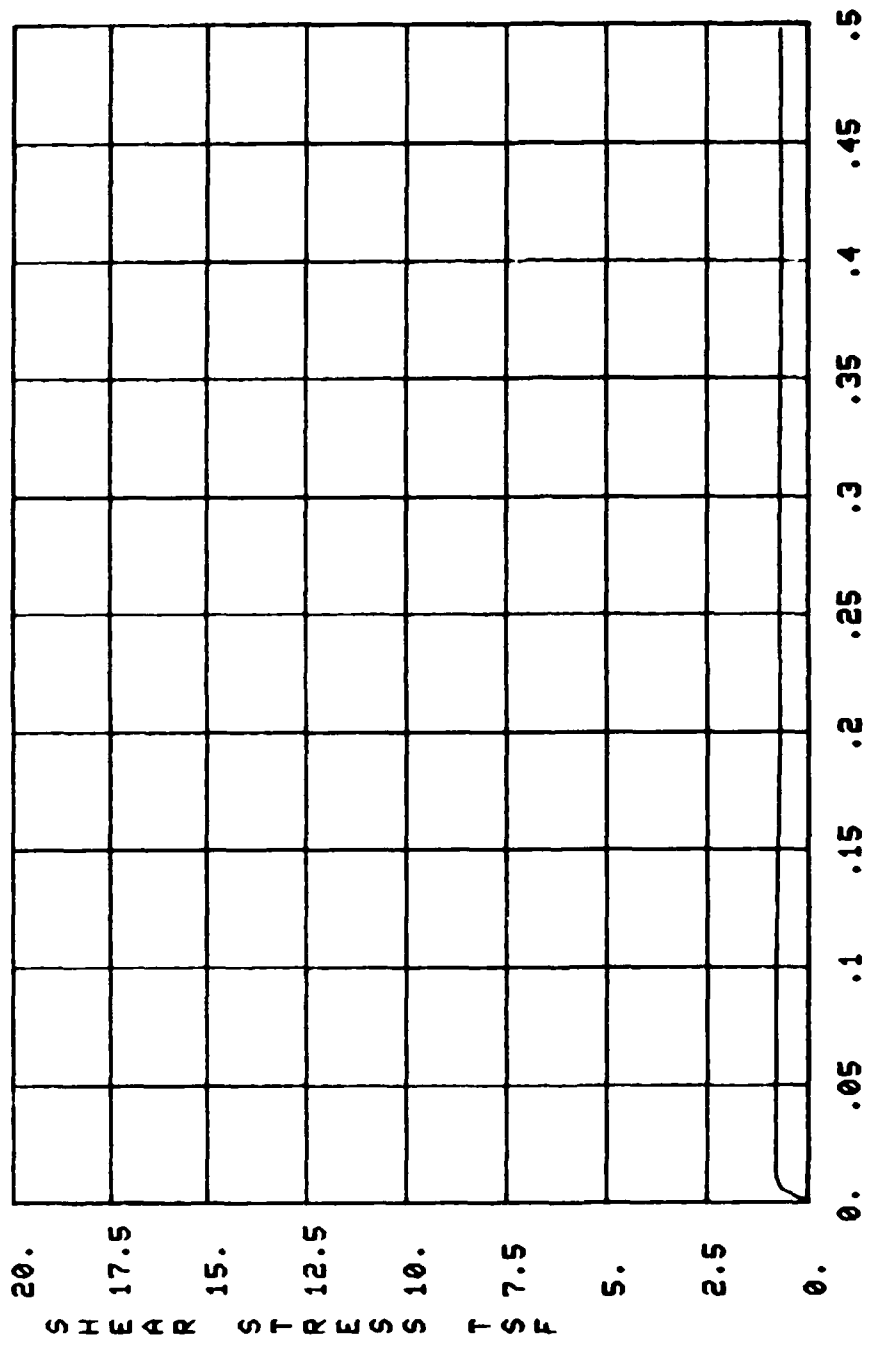

SHEAR DEFORMATION, IN

—— MAXIMUM

DIRECT SHEAR-PRECUIT, INDURATED CLAY ON CON  
 L-10-82, 46.23-46.45, NLI.8 TSF  
 LOCK AND DAM #8 MON RIVER

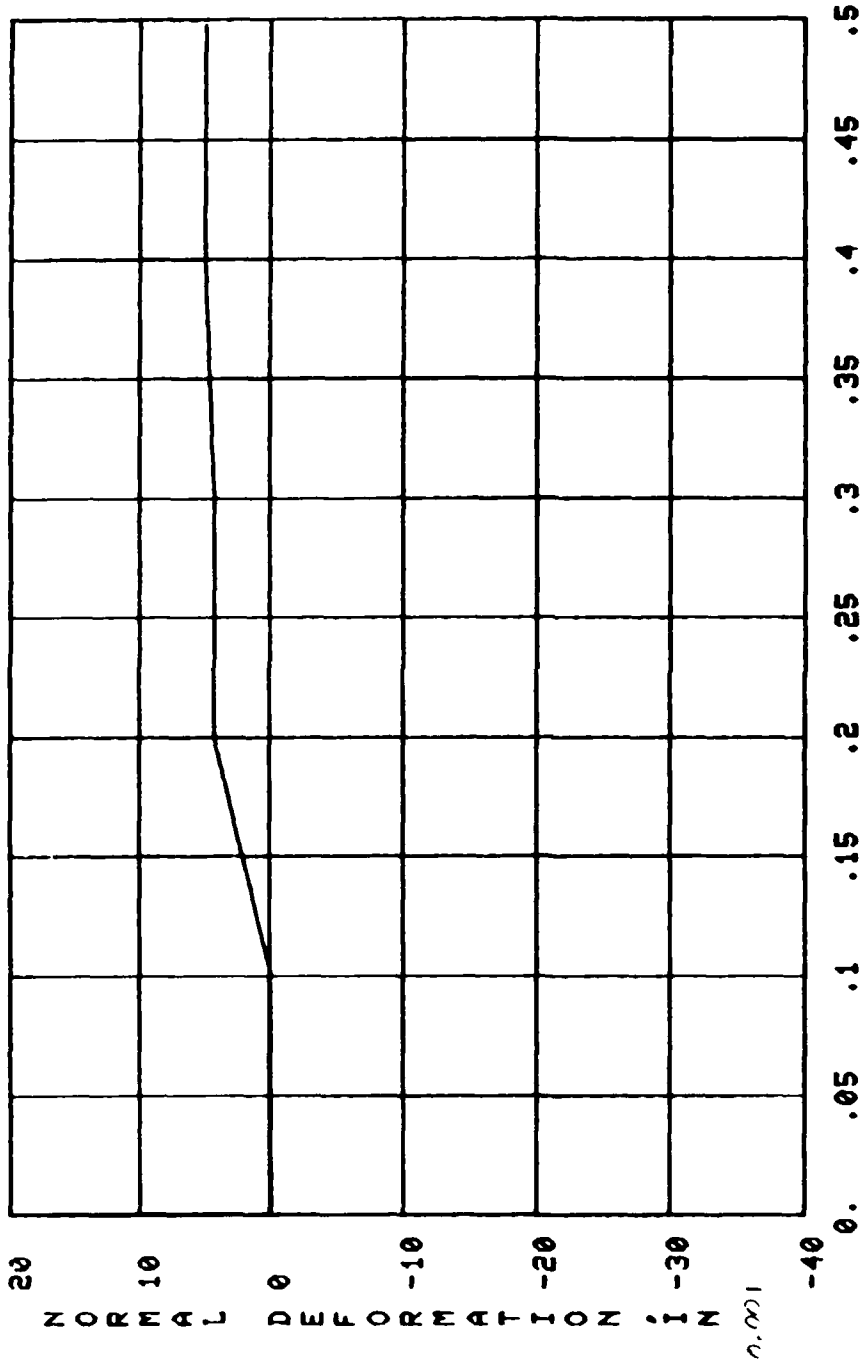

SHEAR DEFORMATION, IN

——— MAXIMUM

DIRECT SHEAR-PRECUIT, INDURATED CLAY ON CON  
 L-10-82, 46.23-46.45, NL1.8 TSF  
 LOCK AND DAM #8 MON RIVER

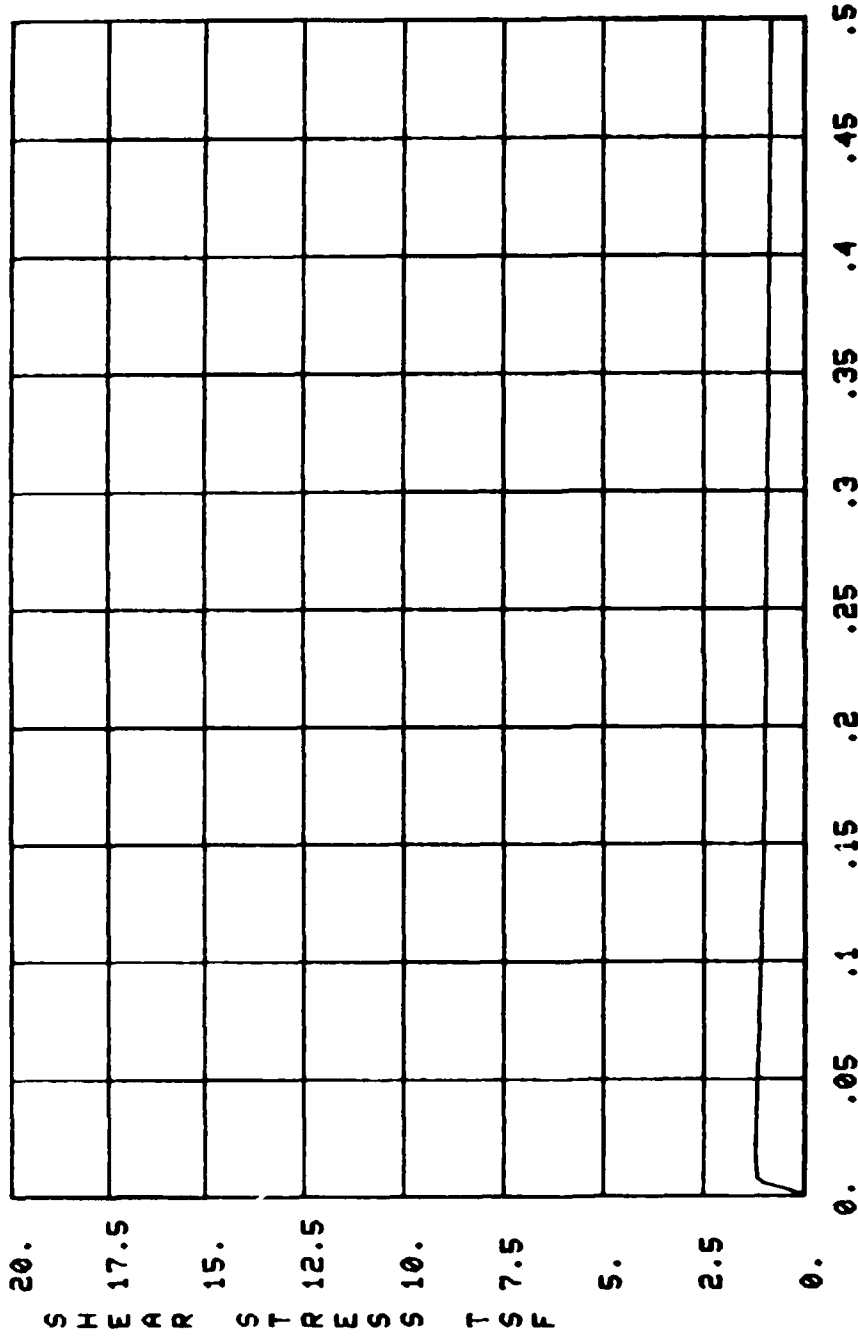

SHEAR DEFORMATION, IN

————— MAXIMUM

DIRECT SHEAR-PRECUIT, INDURATED CLAY ON CON  
L-10-82, 59.07-59.30 FT, NL3.6 TSF  
LOCK AND DAM #8 MON RIVER

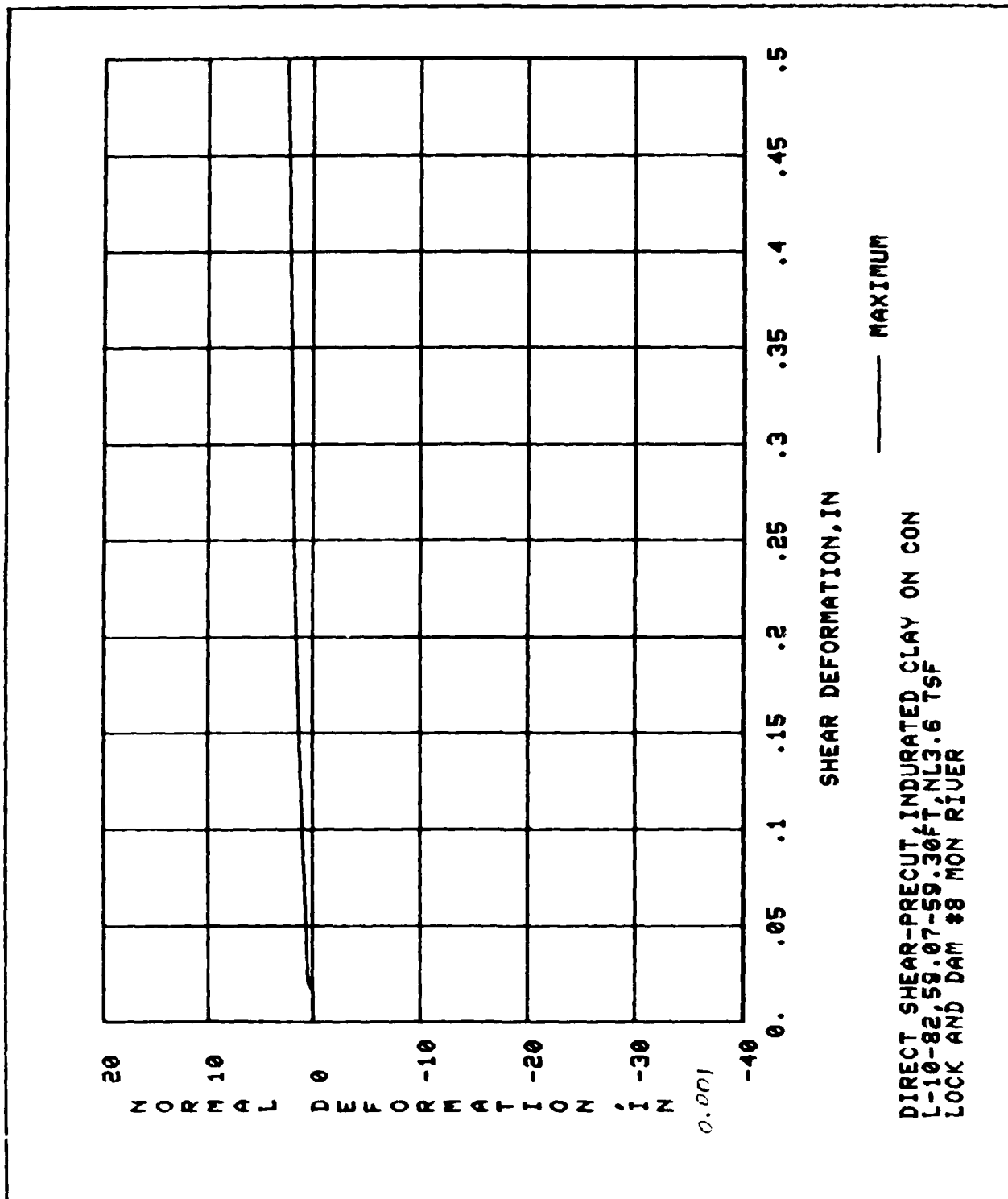
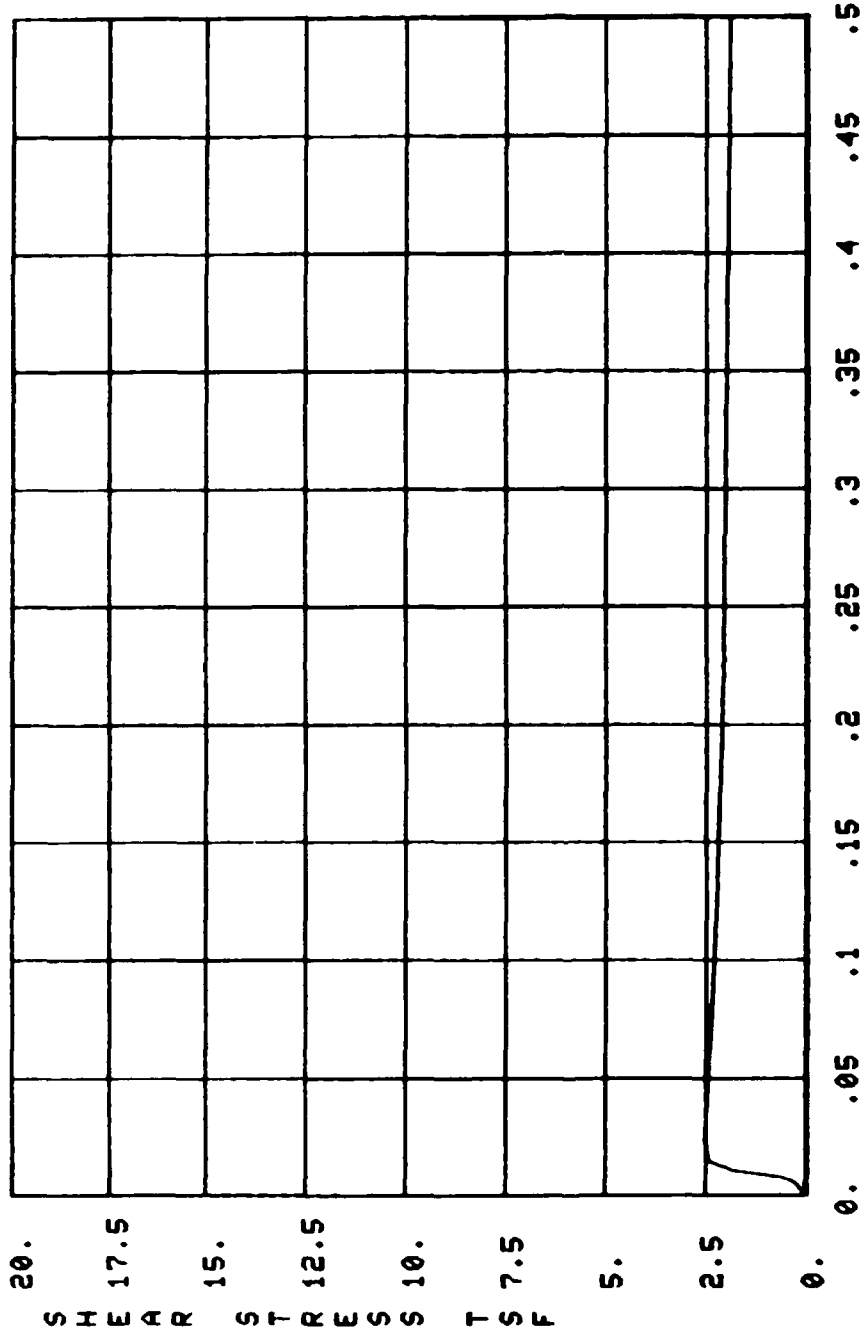

PLATE 22

DIRECT SHEAR-PRECUIT, INDURATED CLAY ON CON  
 L-10-82, 59.07-59.30 FT, NL3.6 TSF  
 LOCK AND DAM #8 MON RIVER



SHEAR DEFORMATION, IN

—— MAXIMUM

DIRECT SHEAR-PRECUIT, INDURATED CLAY ON CON  
 L-10-82, 61.15-61.32 FT, NL7.2 TSF  
 LOCK AND DAM #8 MON RIVER

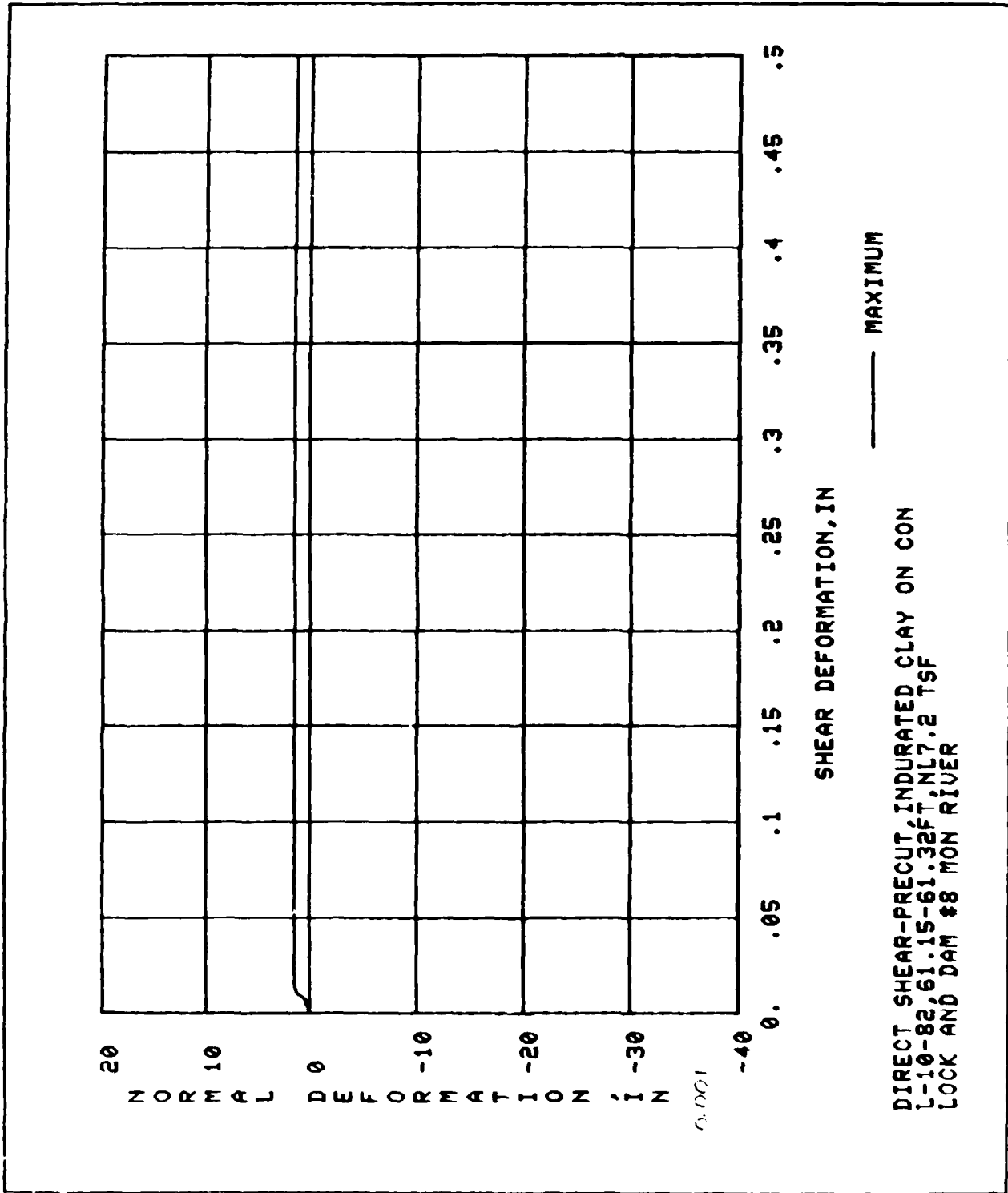
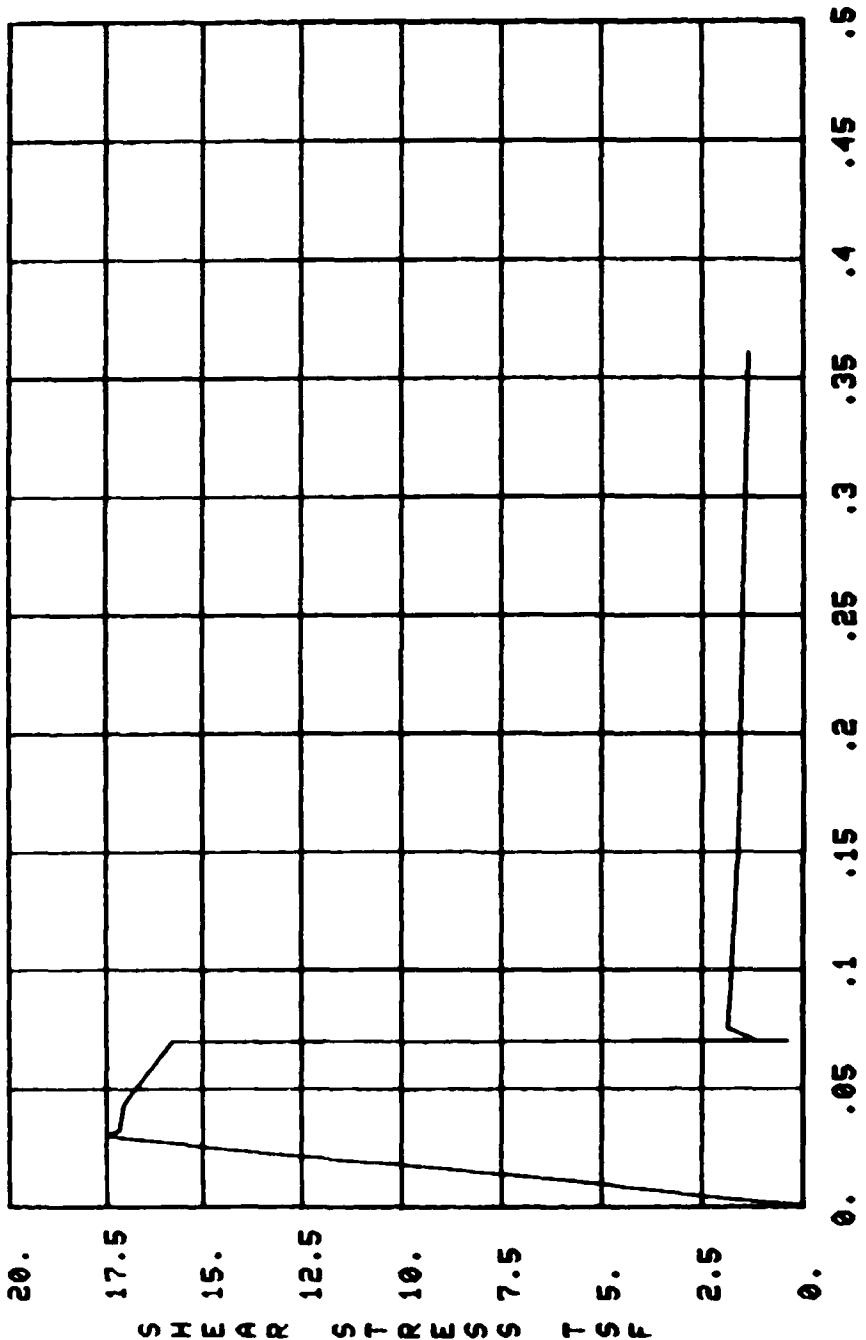

PLATE 24



SHEAR DEFORMATION, IN

—— MAXIMUM

**DIRECT SHEAR-  
L-1-82, 49.28-49.50', INDURATED CLAY  
LOCK & DAM 8, MON RIVER**  
CONCRETE BONDED TO ROCK

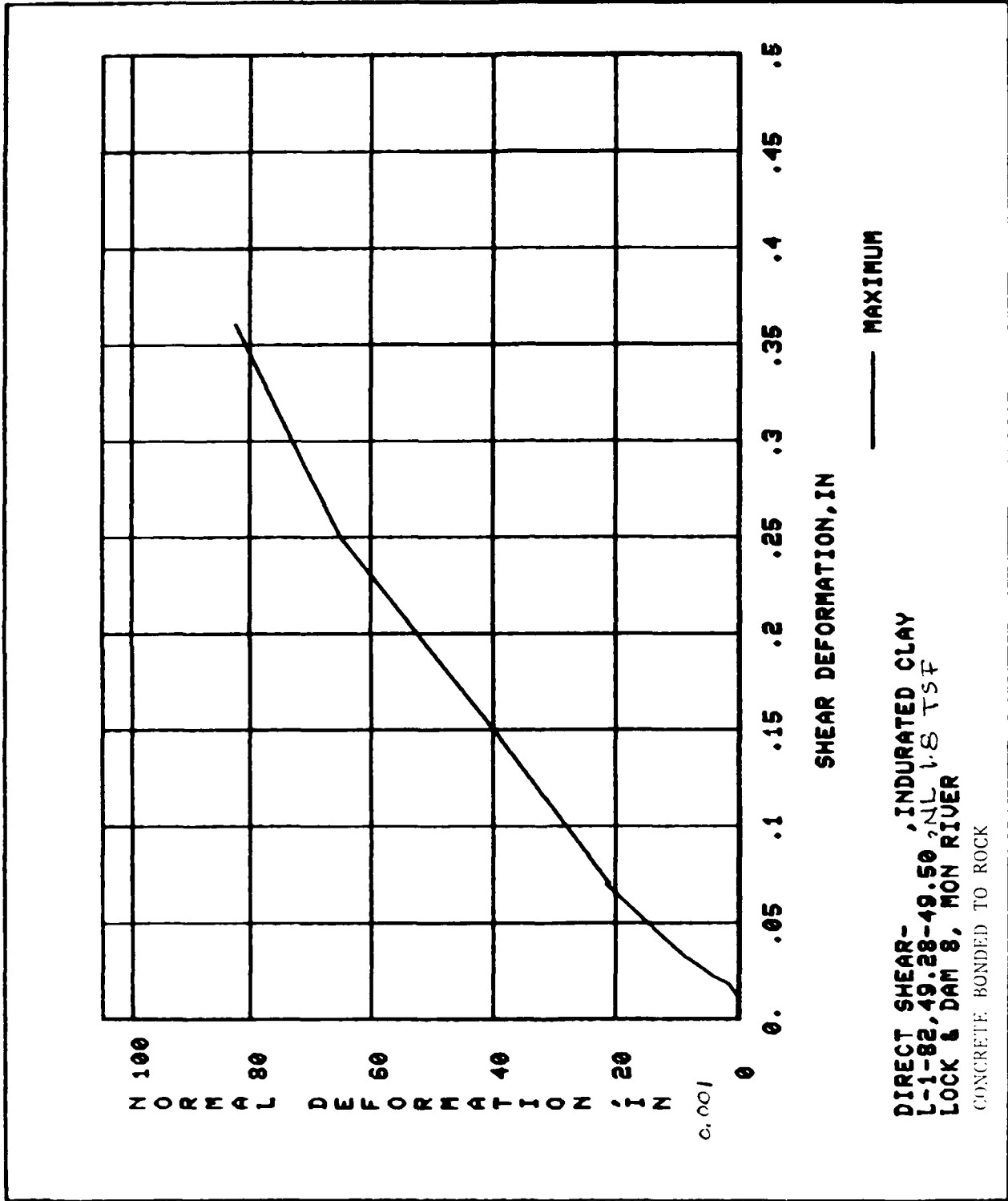

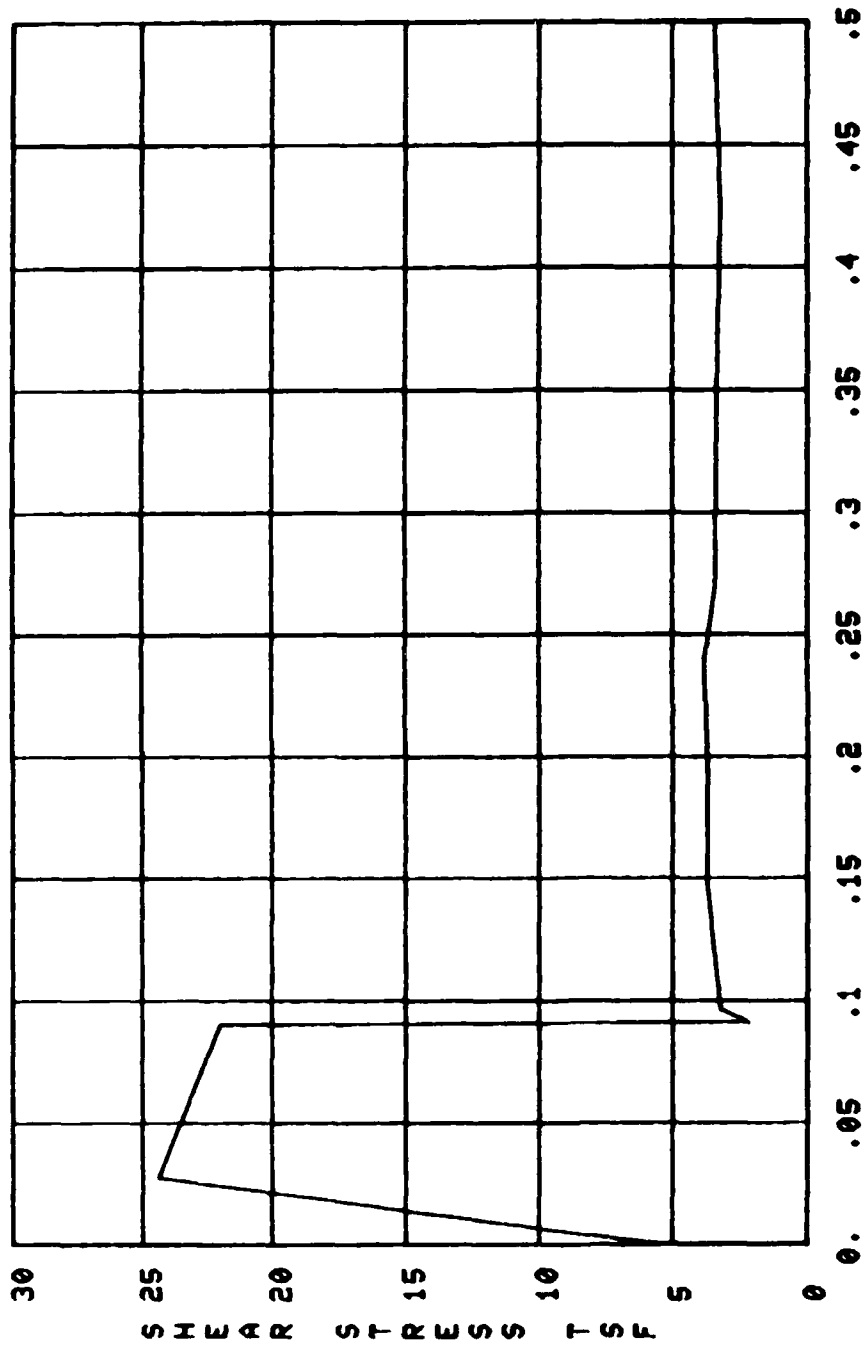

SHEAR DEFORMATION, IN

—— MAXIMUM

DIRECT SHEAR-  
 L-1-82, 49.50-49.70, INDURATED CLAY  
 LOCK & DAM 8, MON RIVER  
 CONCRETE BONDED TO ROCK

Normal deformation  
gauge inoperative;  
no curve for the  
normal versus shear  
deformation.

Boring L-1-82  
Depth 49.5-49.7 ft.

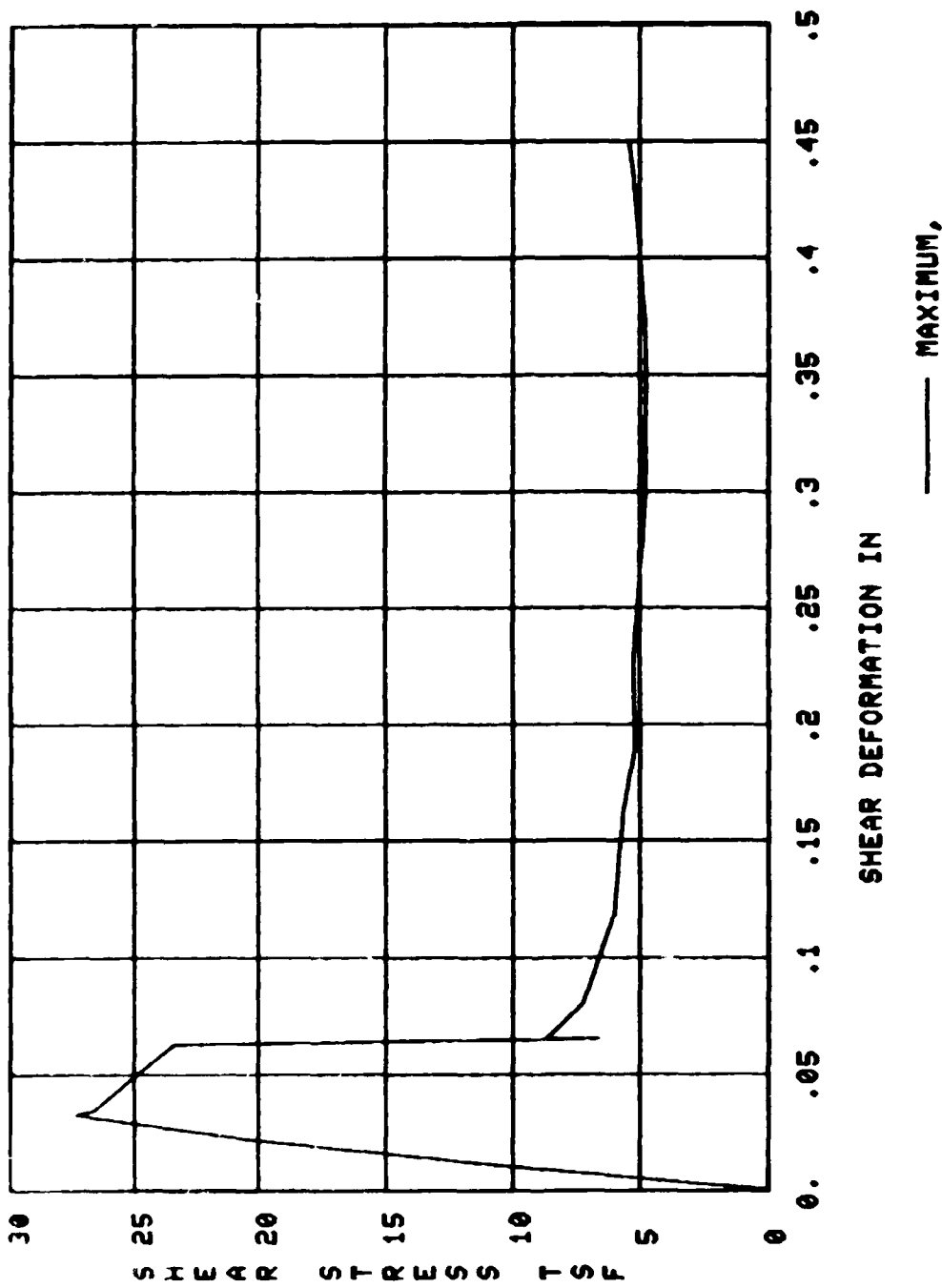

DIRECT SHEAR-  
 L-1-82, 48.85-49.04', INDURATED CLAY  
 LOCK & DAM 8, MON RIVER  
 CONCRETE BONDED TO ROCK

SHEAR DEFORMATION IN

—— MAXIMUM,

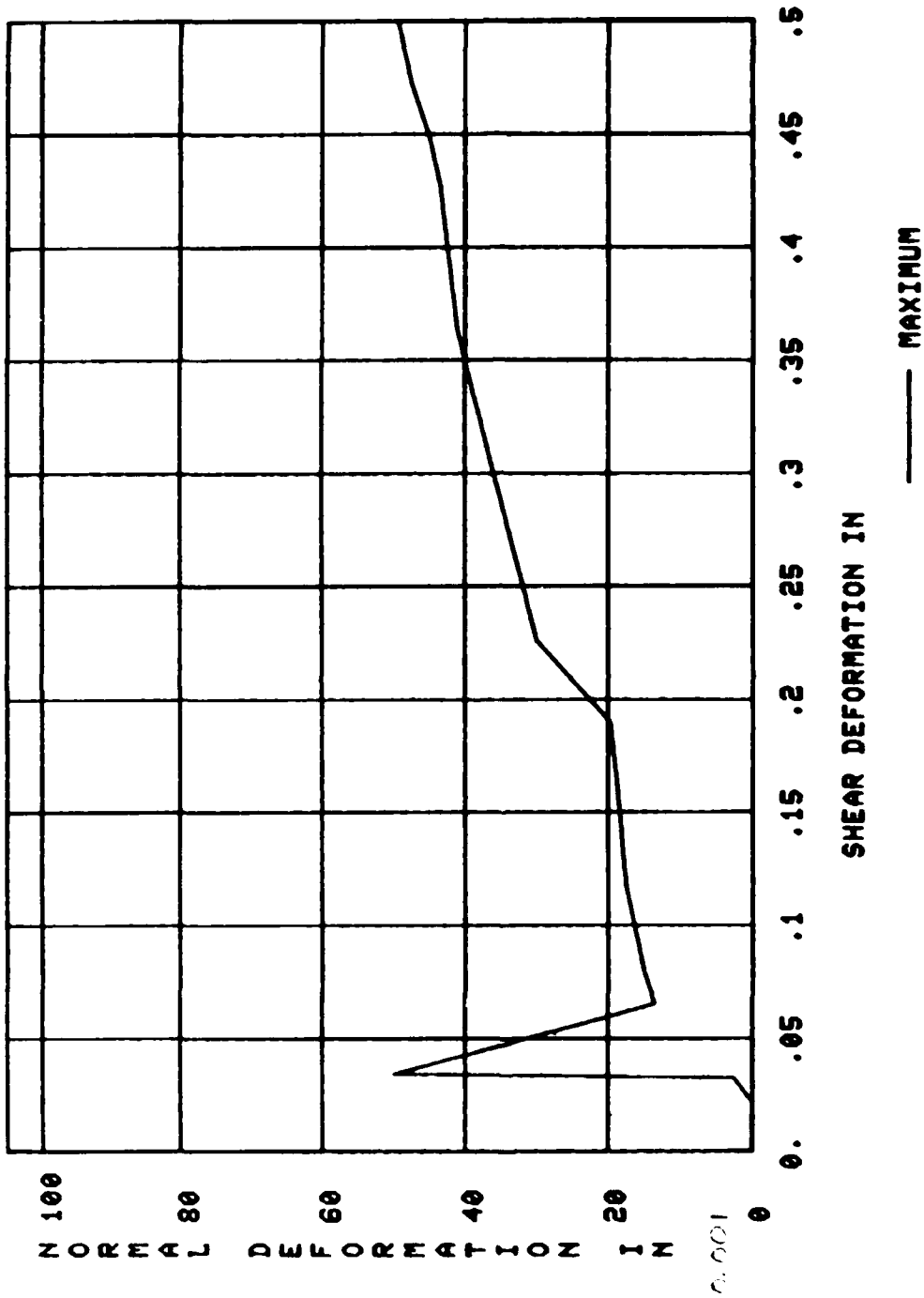

DIRECT SHEAR-  
 L-1-82, 48.85-49.04', INDURATED CLAY  
 LOCK & DAM 8, MON RIVER  
 CONCRETE BONDED TO ROCK

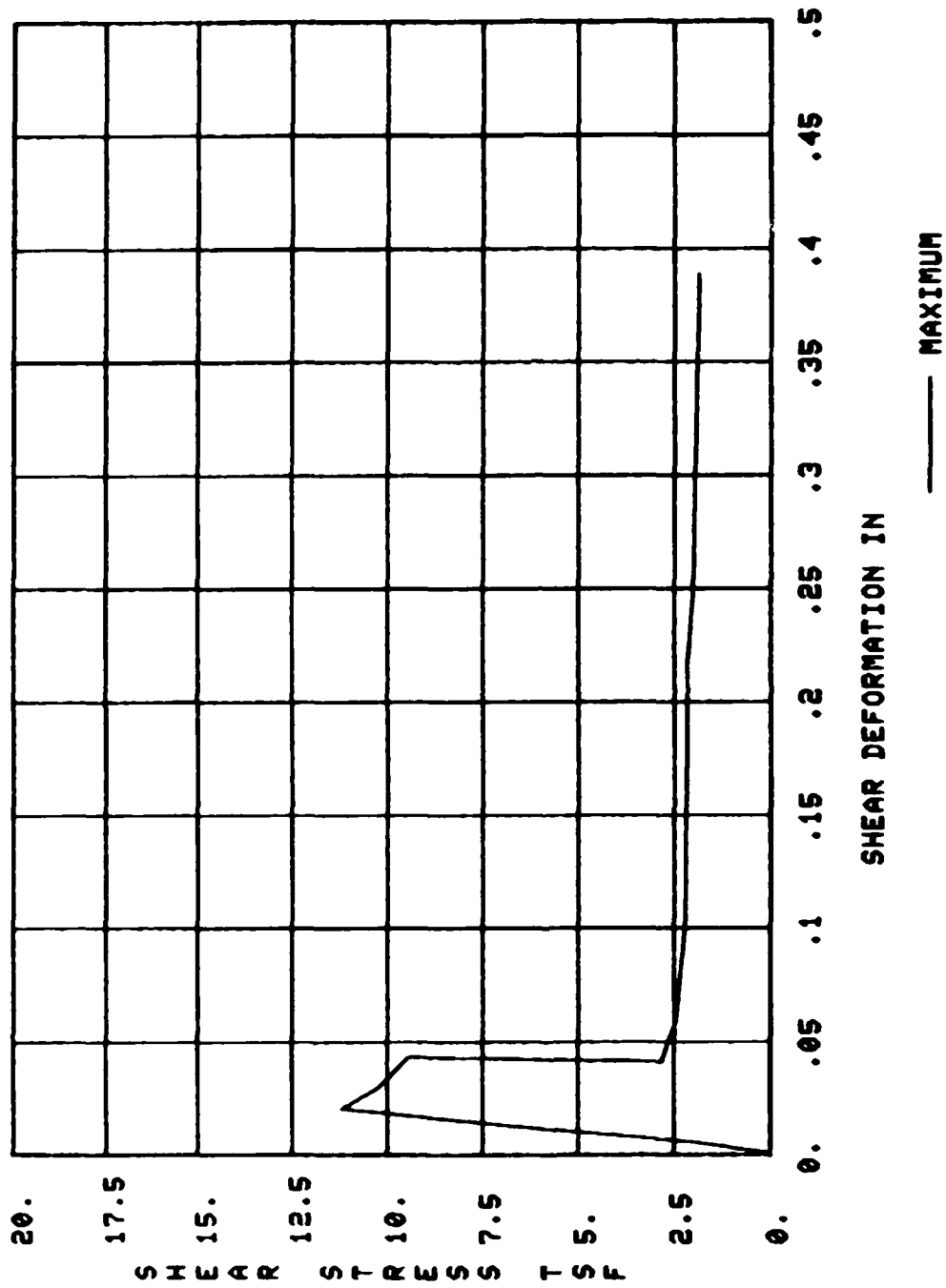

DIRECT SHEAR-  
 L-1-82, 46.40-46.63 IN. I.B.TSF  
 LOCK & DAM 8, MON RIVER  
 CONCRETE BONDED TO ROCK

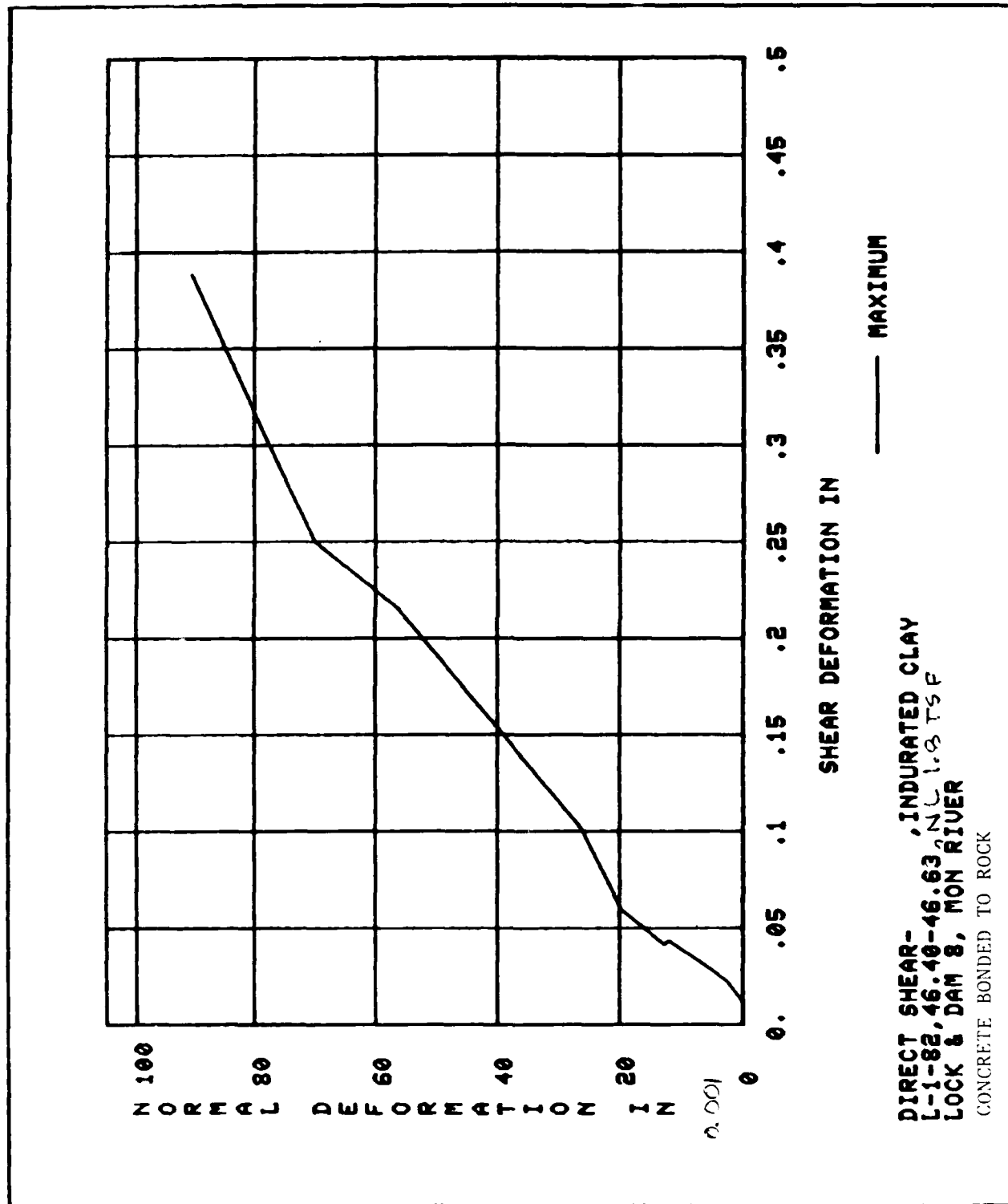
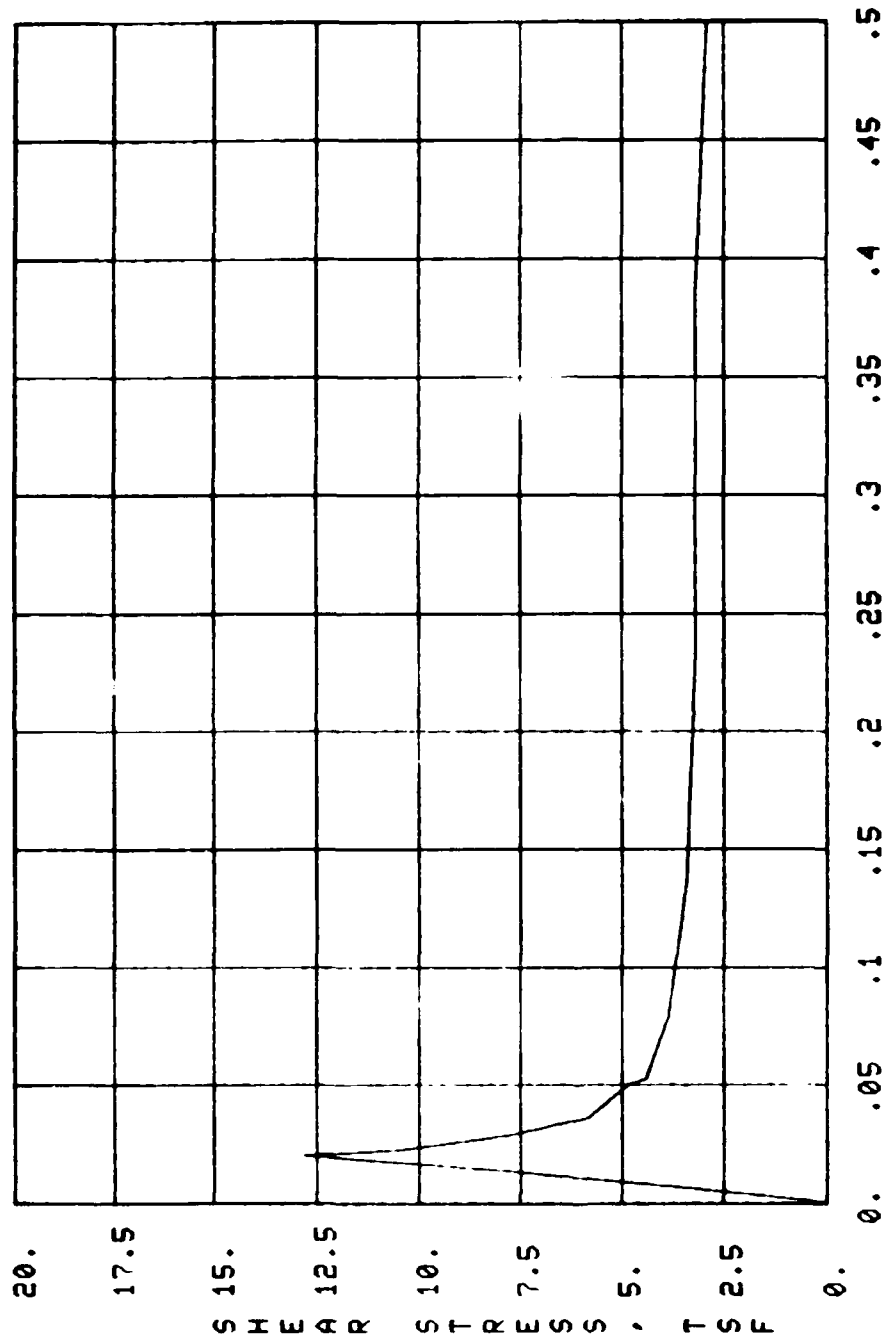

PLATE 32



SHEAR DEFORMATION, IN.

—— MAXIMUM

DIRECT SHEAR, CON BONDED TO ROCK, INDURATED CLAY  
 L-1-82, 45.95-64.15  
 LOCK ABND DAM #8, MON RIVER

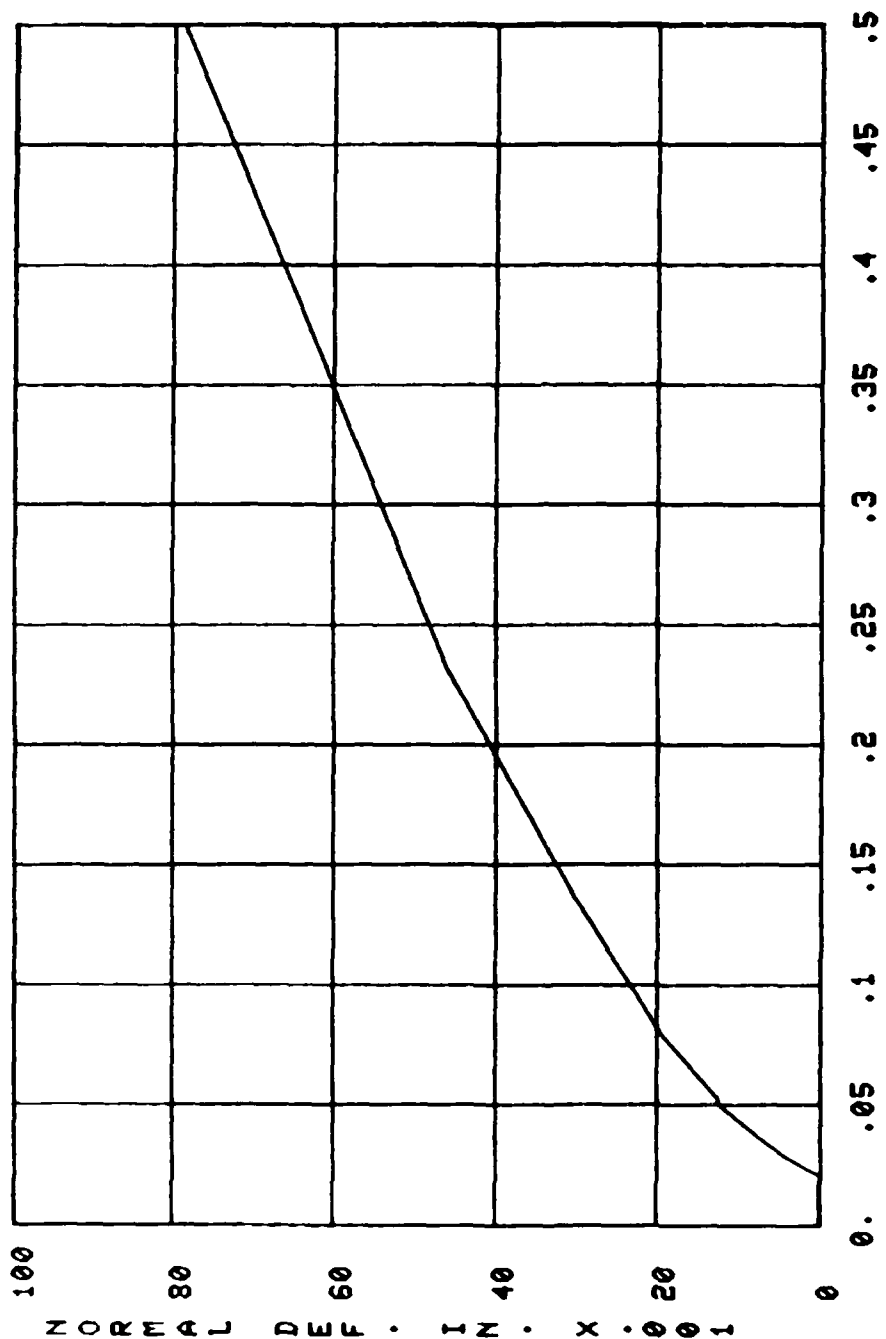

SHEAR DEFORMATION, IN.

—— MAXIMUM

DIRECT SHEAR, CON BOUNDED TO ROCK, INDURATED CLAY  
 L-1-82, 45.95-64.15  
 LOCK AND DAMN #8, MON RIVER

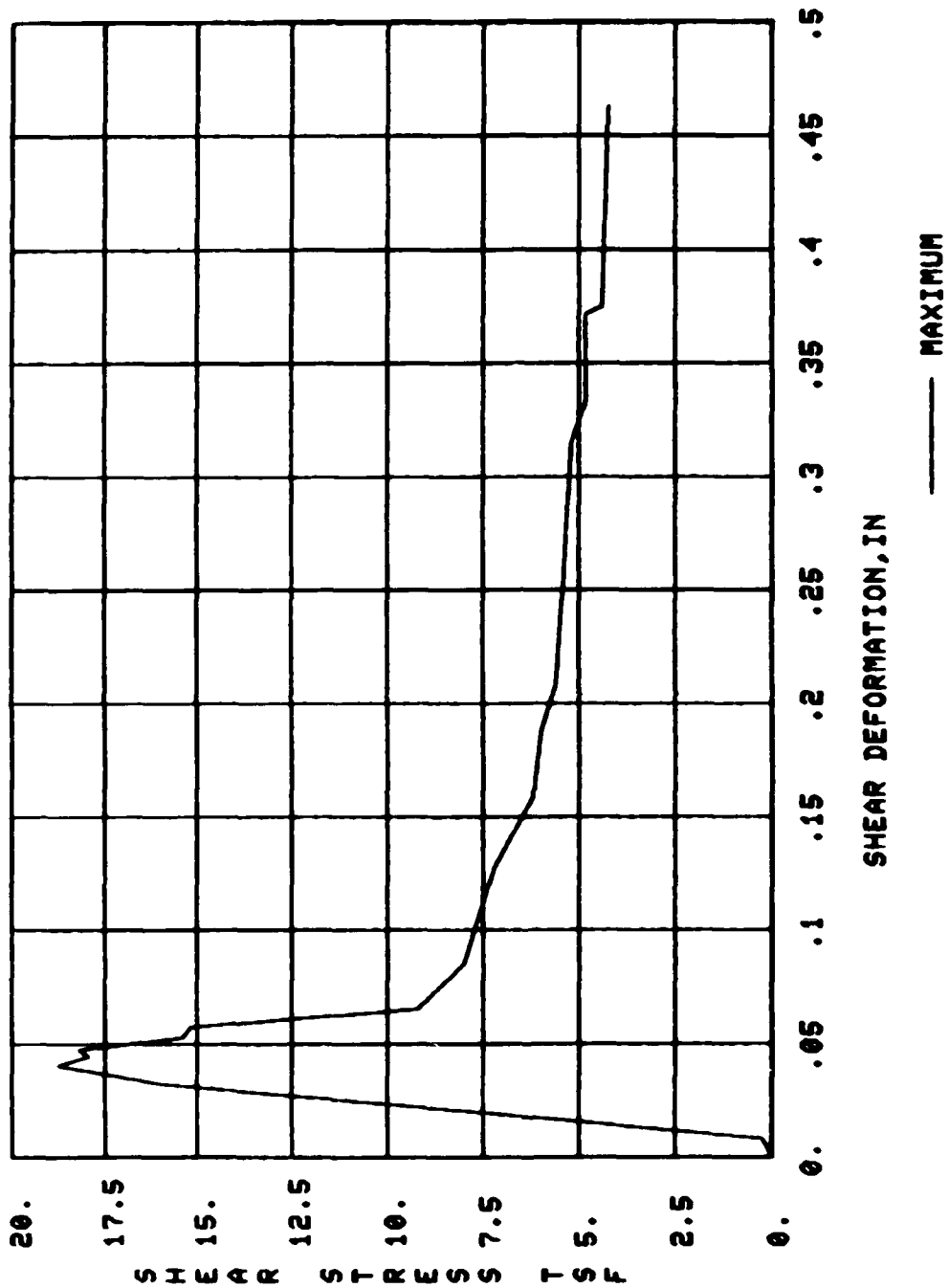

DIRECT SHEAR-  
 L-1-82, 46.70-46.90', INDURATED CLAY  
 NL T.2 T5F  
 LOCK & DAM 8, MON RIVER  
 CONCRETE BONDED TO ROCK

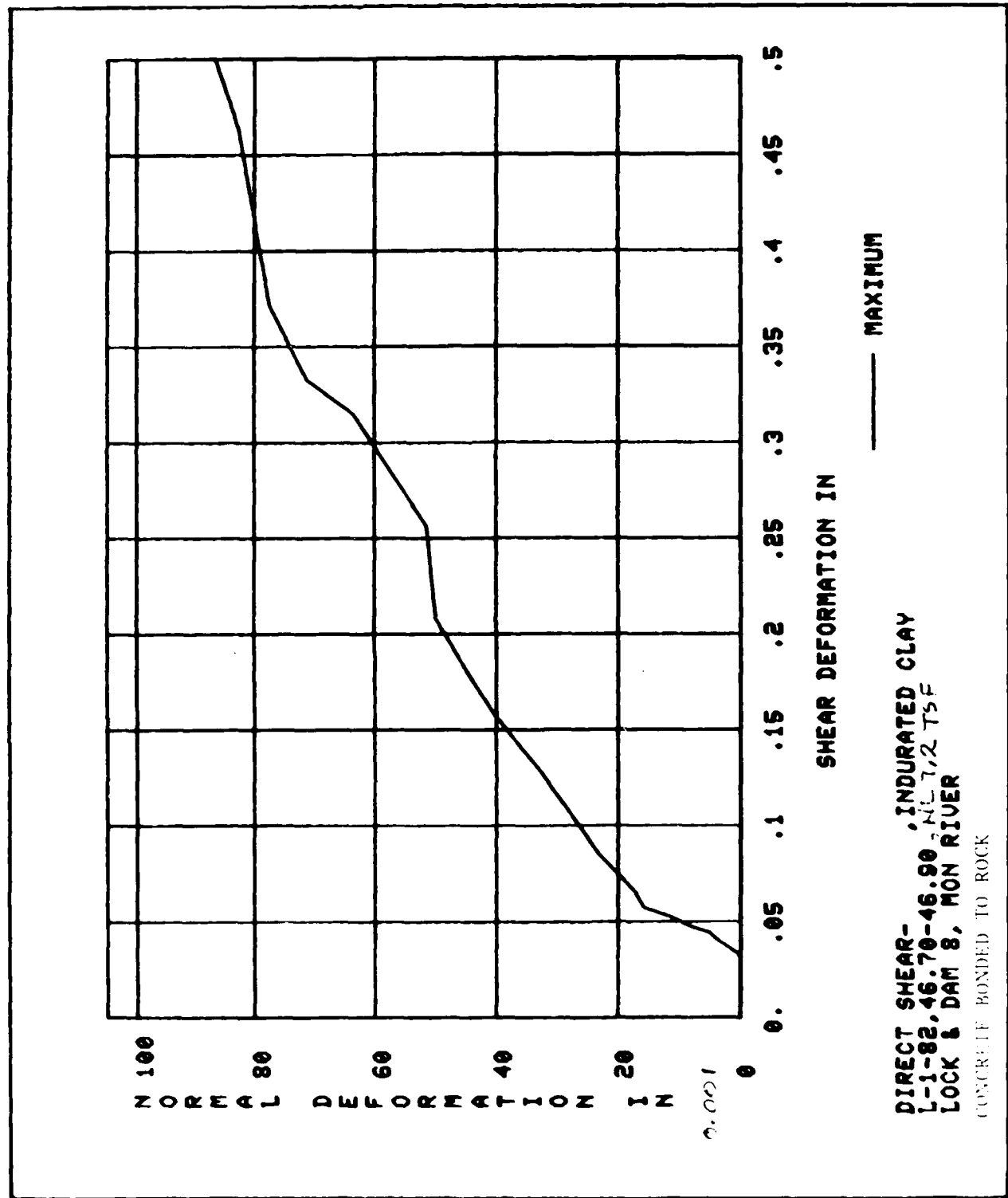

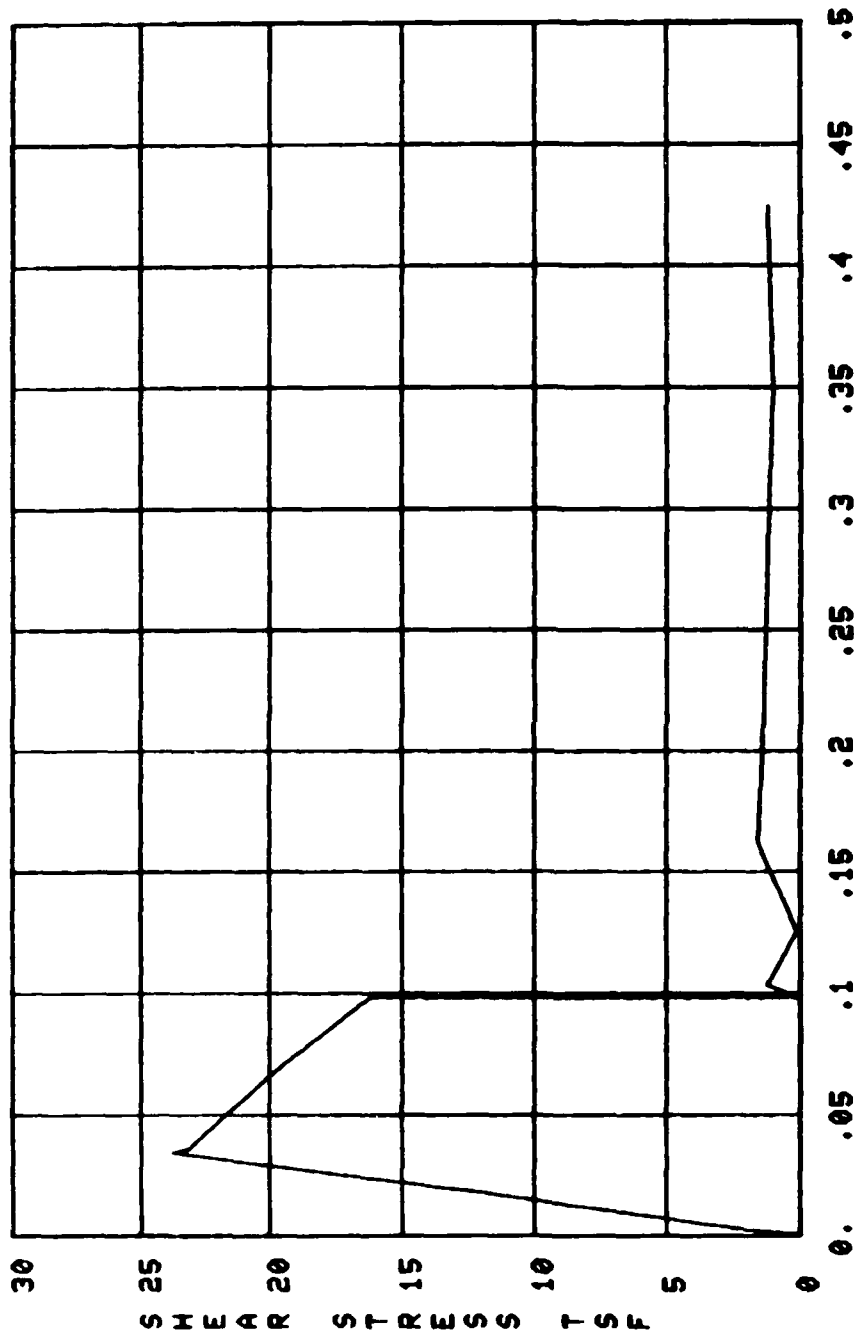

SHEAR DEFORMATION, IN

MAXIMUM

DIRECT SHEAR-  
 L-1-82, 49.04-49.27, INDURATED CLAY  
 LOCK & DAM 8, MON RIVER  
 CONCRETE BONDED TO ROCK

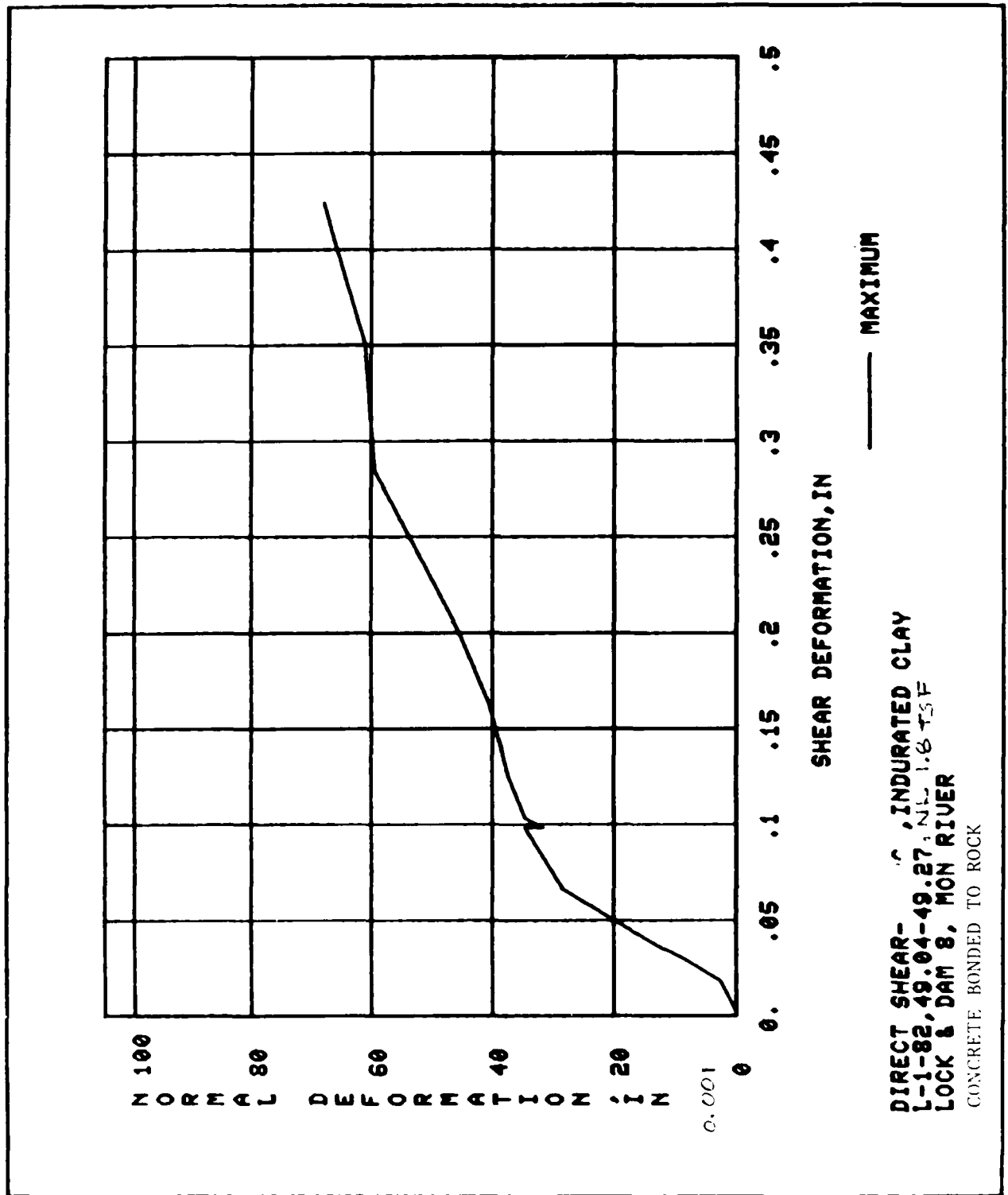
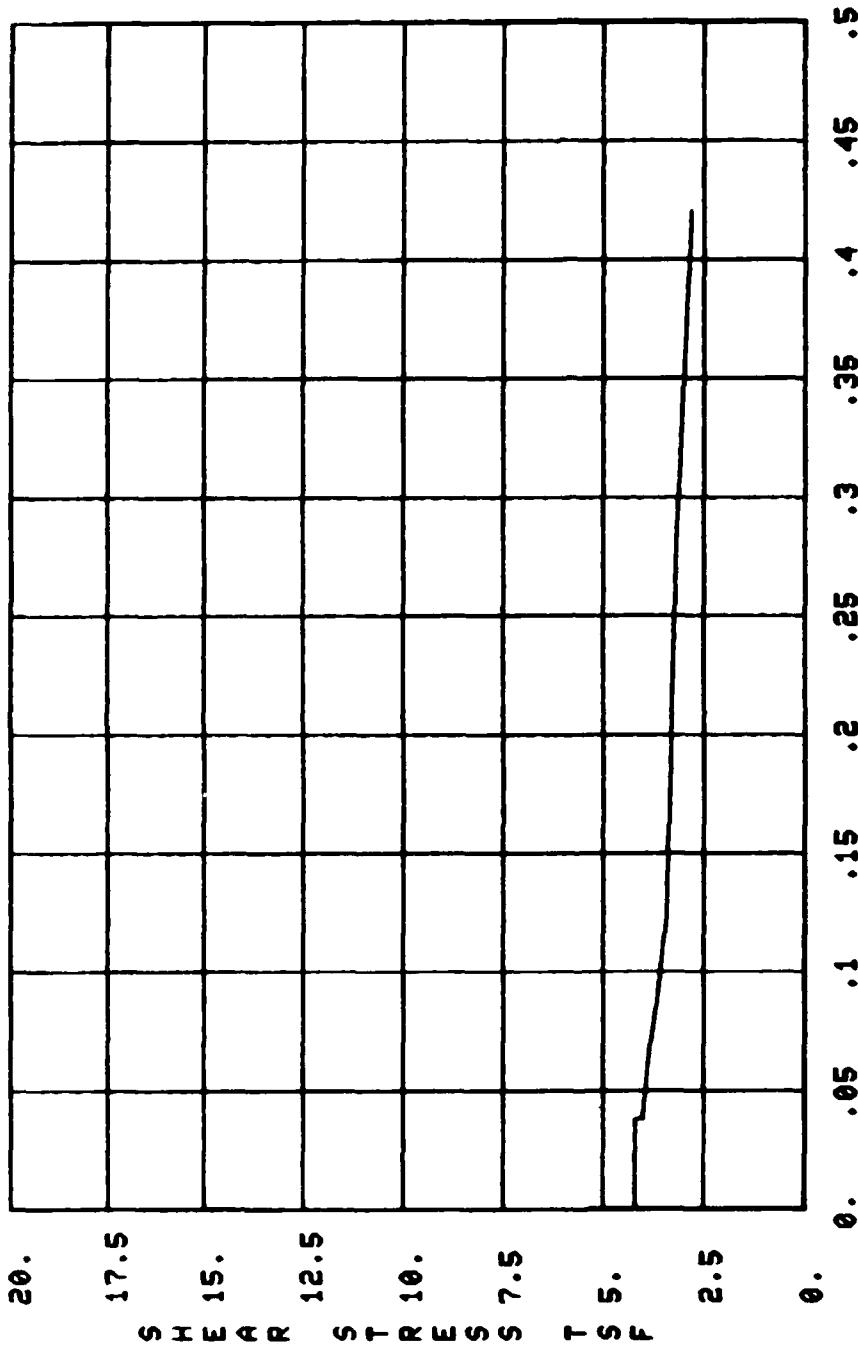

PLATE 38



SHEAR DEFORMATION, IN ——— MAXIMUM

DIRECT SHEAR-  
 L-10-82, 49.53-49.76' INDURATED CLAY  
 LOCK & DAM 8, MON RIVER  
 CONCRETE BONDED TO ROCK

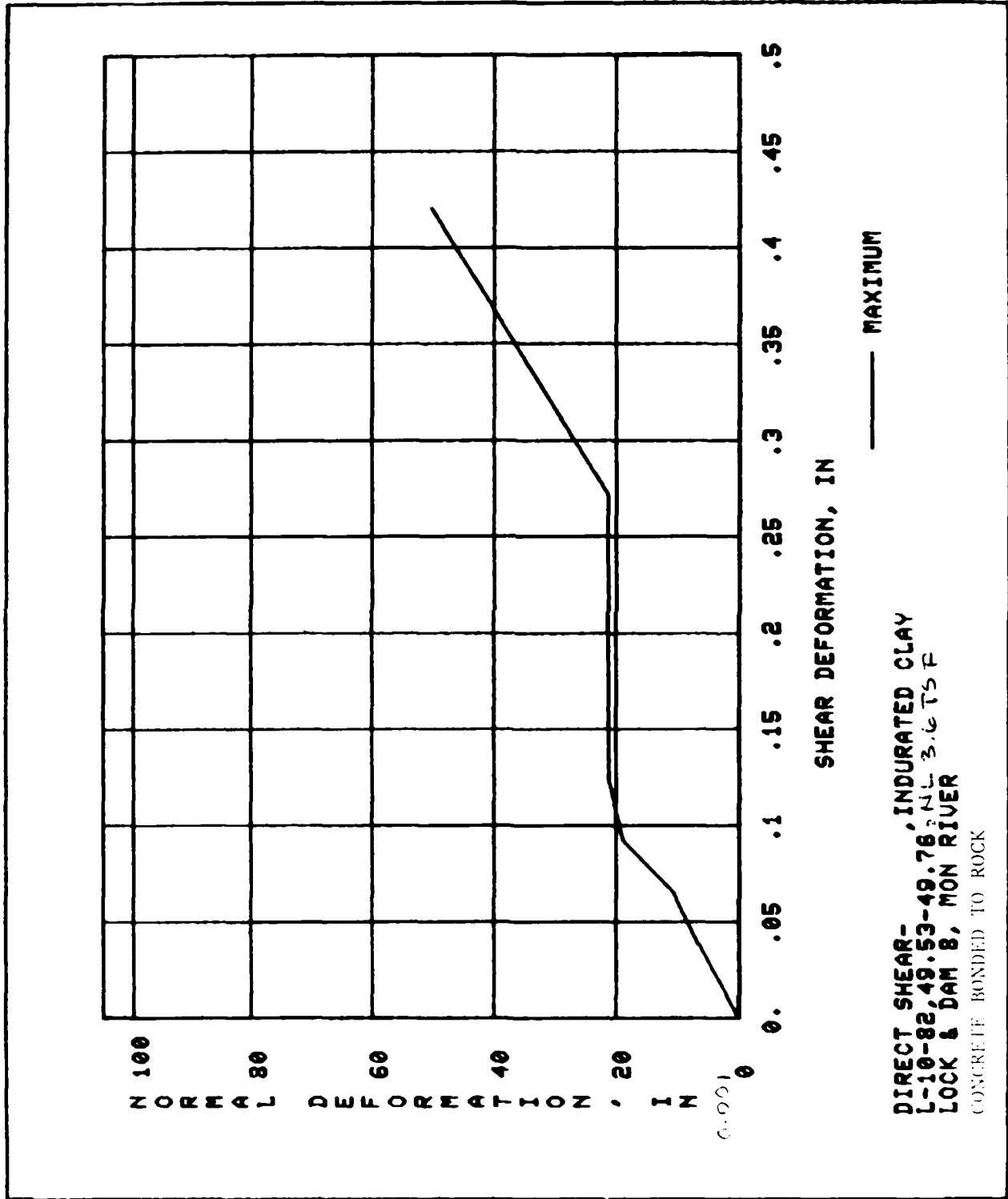
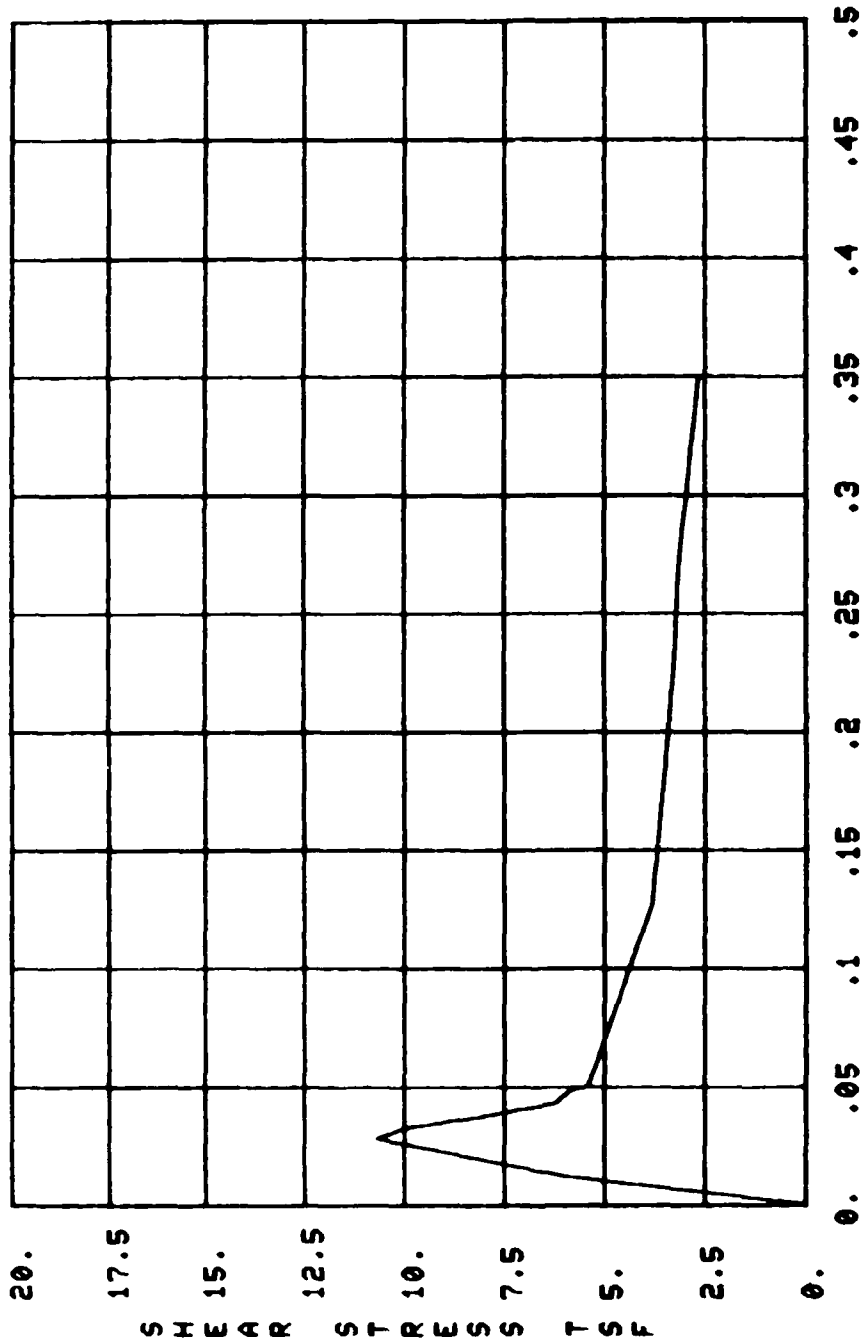

PLATE 40



SHEAR DEFORMATION, IN

—— MAXIMUM

DIRECT SHEAR-  
 L-10-82, 49.76-50.00', INDURATED CLAY  
 NL T-2 T5F  
 LOCK & DAM 8, MON RIVER  
 CONCRETE BONDED TO ROCK

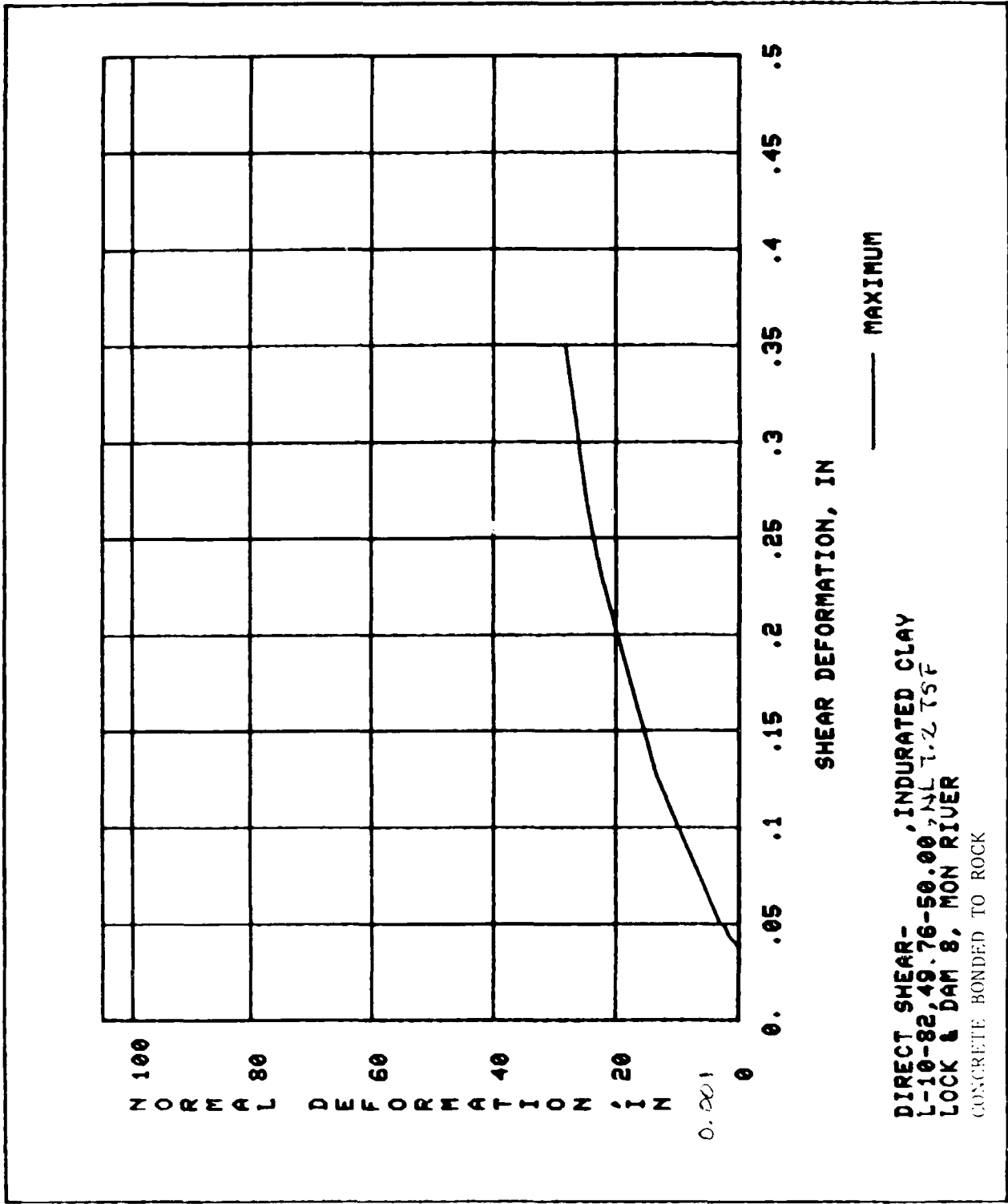

PLATE 42

AD-A183 789

CONDITION SURVEY OF LOCK NUMBER 8 MONONGAHELA RIVER(U)  
ARMY ENGINEER WATERWAYS EXPERIMENT STATION VICKSBURG MS  
STRUCTURES LAB R L STONE JUN 87 WES/MP/SL-87-4

2/2

UNCLASSIFIED

F/G 13/2

NL

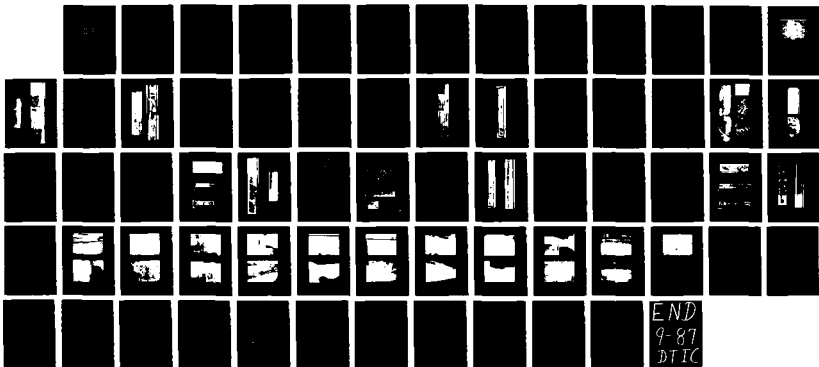

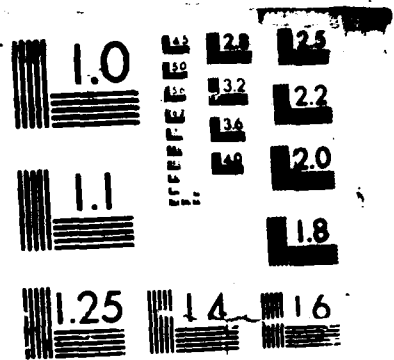

MICROCOPY RESOLUTION TEST CHART

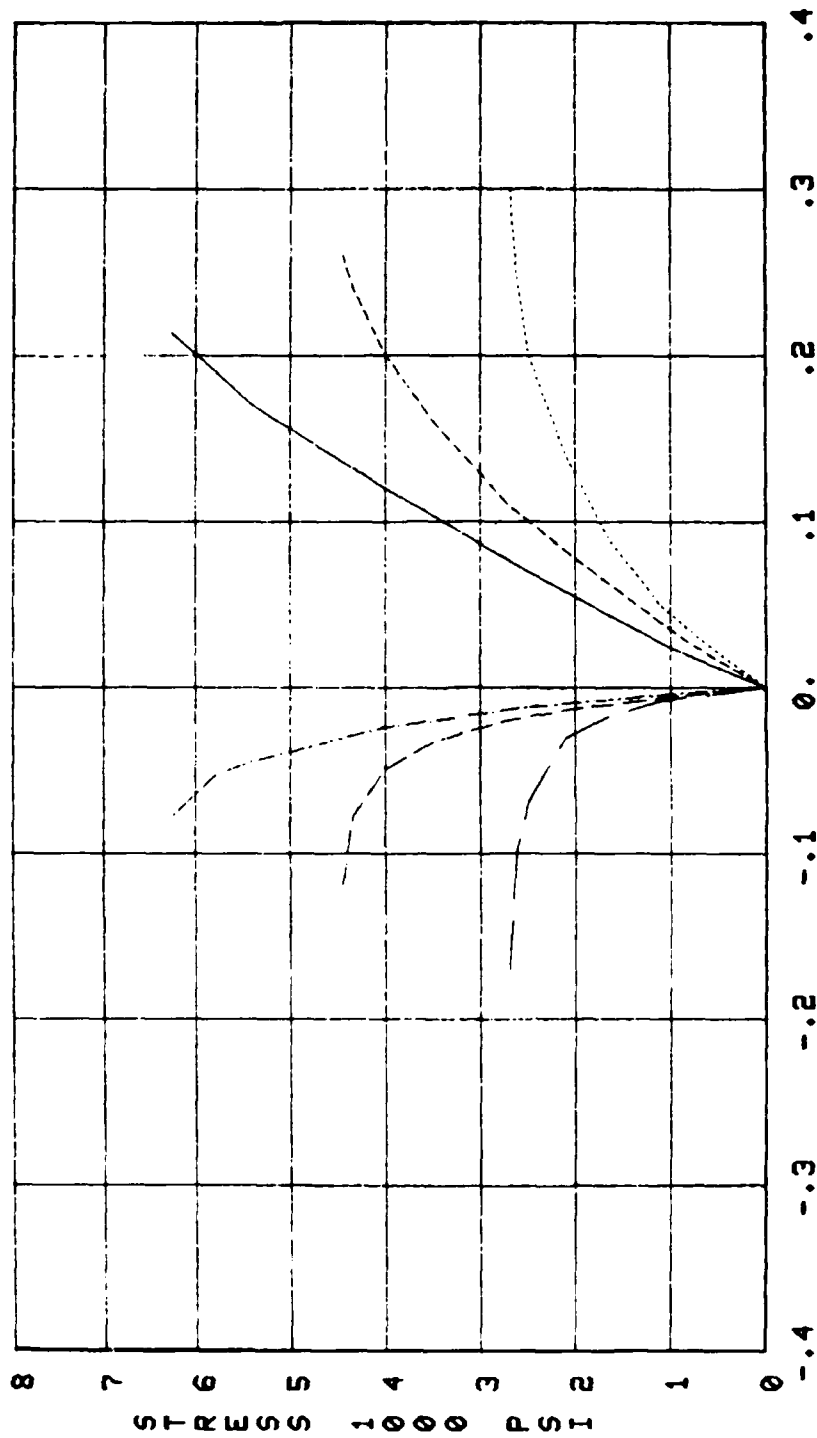

CONCRETE COMPRESSIVE STRESS-STRAIN  
 LOCK & DAM 8, MON RIVER  
 L-1-82, 1.7-2.7, 21.0-22.0, 40.0, -41.0  
 AXIAL L-1 1.7-2.7  
 DIAM L-1 1.7-2.7  
 AXIAL L-1 21.0-22.0  
 DIAM L-1 21.0-22.0  
 AXIAL L-1 40.0-41.0  
 DIAM L-1 40.0-41.0

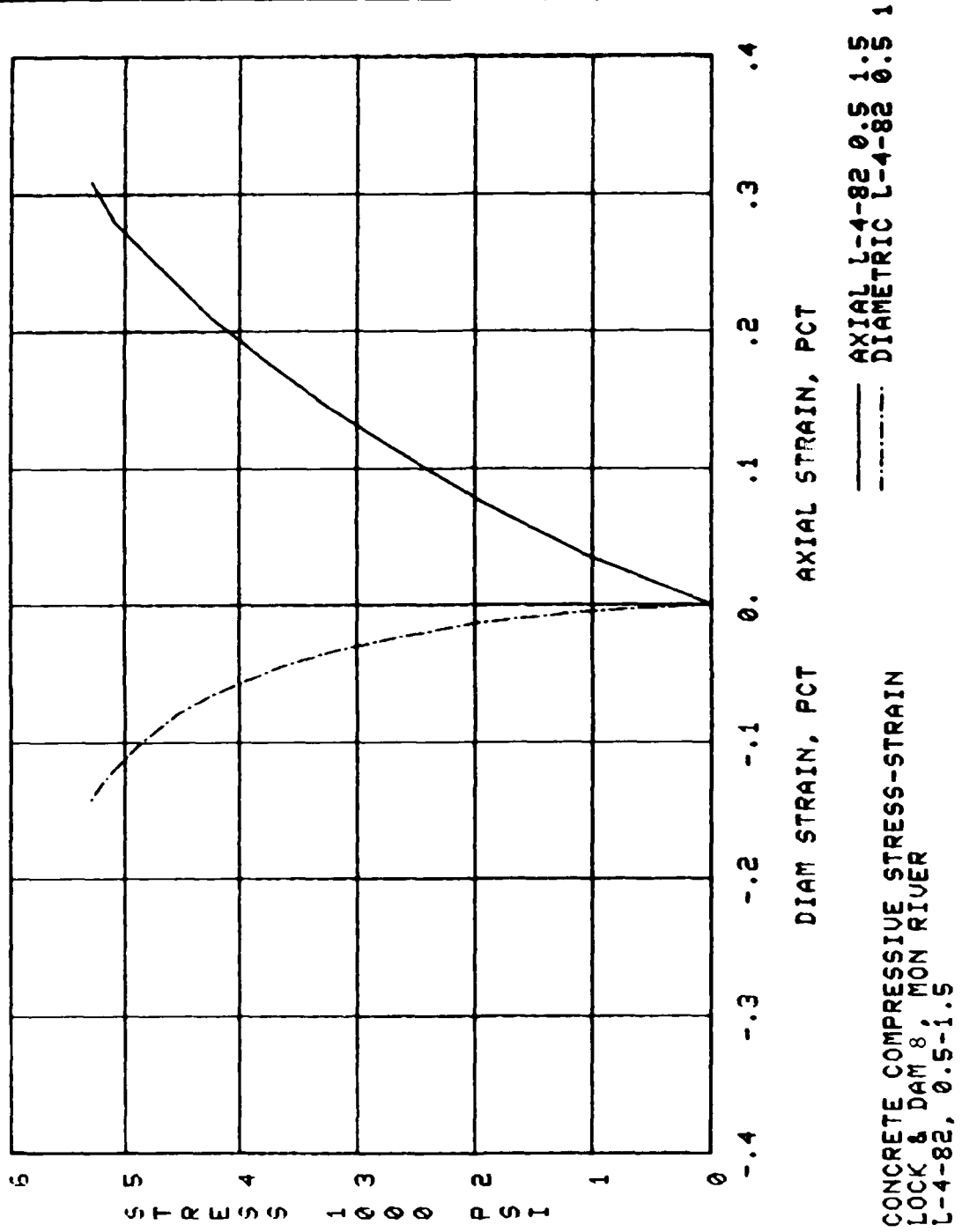

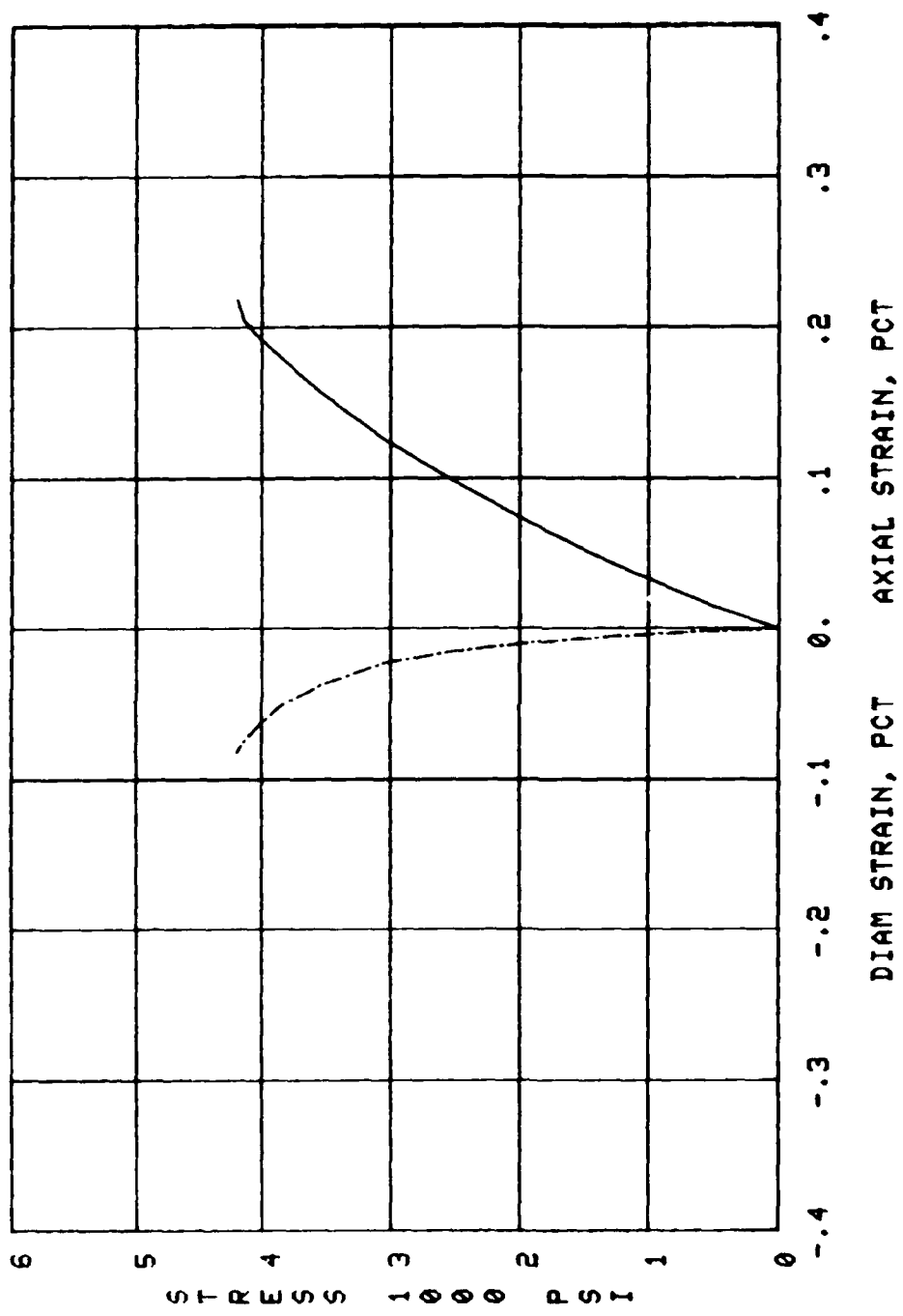

CONCRETE COMPRESSIVE STRESS-STRAIN  
 LOCK & DAM 8, MON RIVER  
 L-8-82, 2.5-3.4

AXIAL L-8-82 2.5-3.4  
 DIAM L-8-82 2.5-3.4

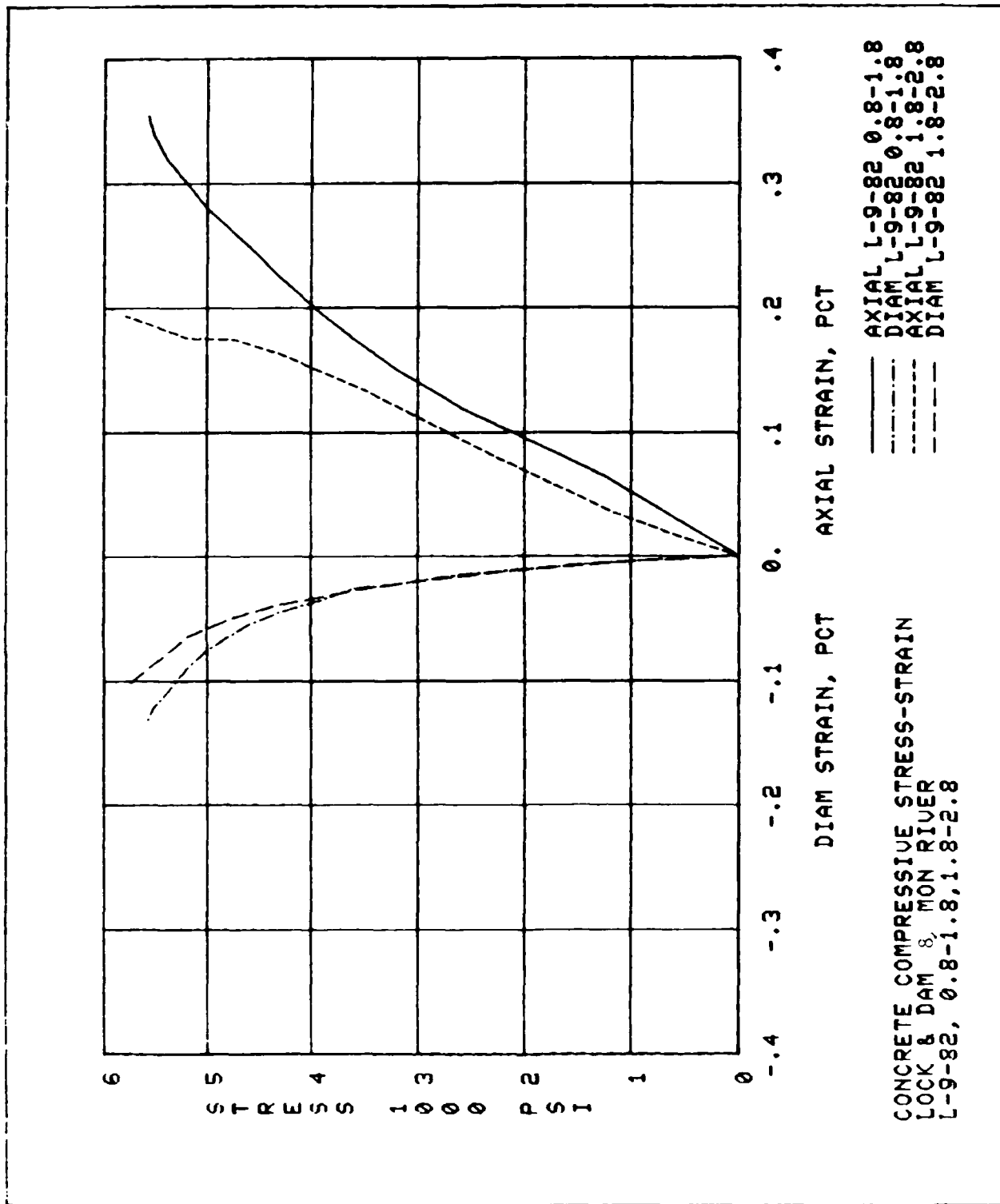
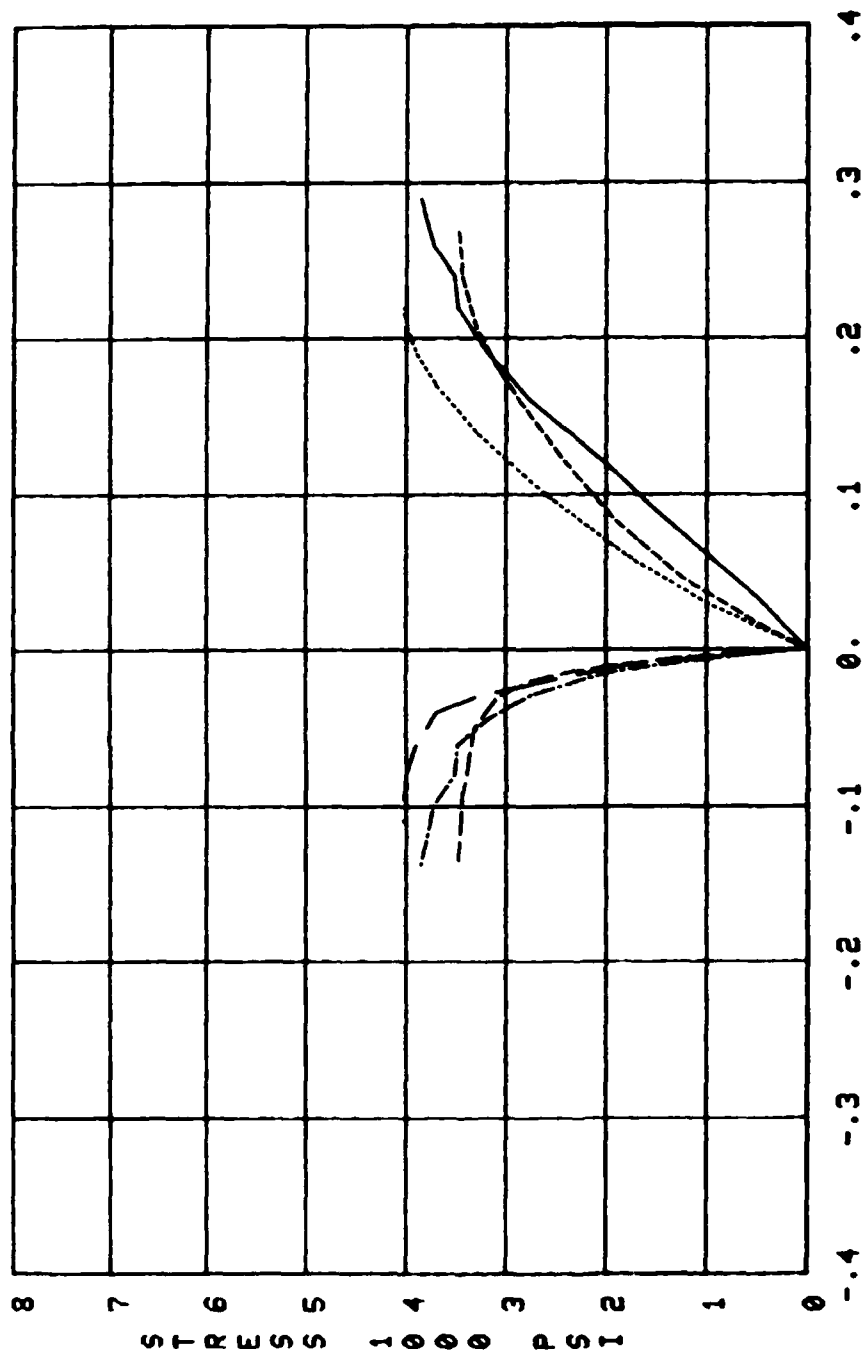

PLATE 46



DIAM STRAIN, PCT      AXIAL STRAIN, PCT

AXIAL L-10 1.0-2.0  
 DIAM L-10 1.0-2.0  
 AXIAL L-10 19.7-20.7  
 DIAM L-10 19.7-20.7  
 AXIAL L-10 37.5-38.5  
 DIAM L-10 37.5-38.5

CONCRETE COMPRESSIVE STRESS-STRAIN  
 LOCK & DAM 8, MON RIVER  
 L-10-82, 1.0-2.0, 19.7-20.7, 37.5-38.5

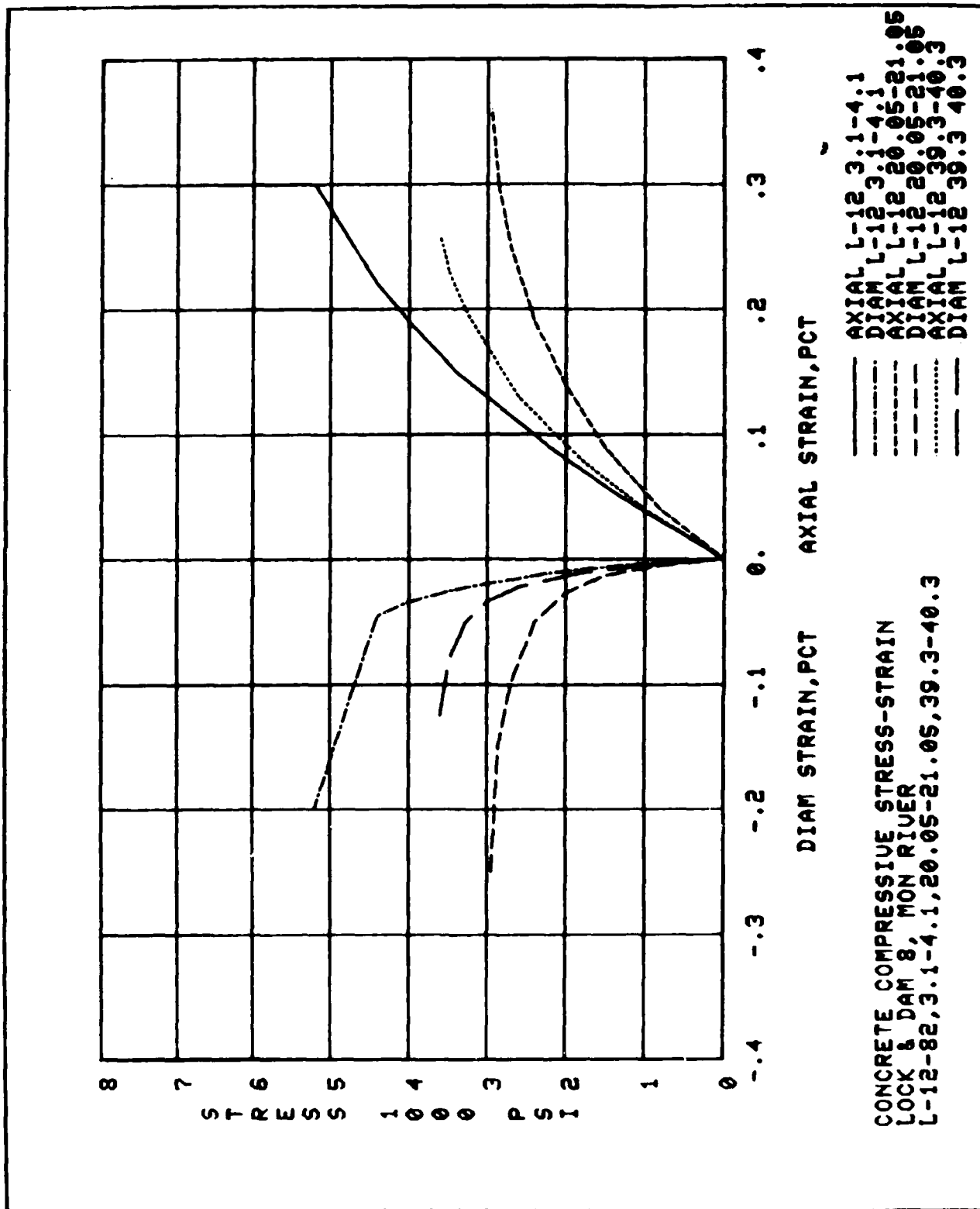

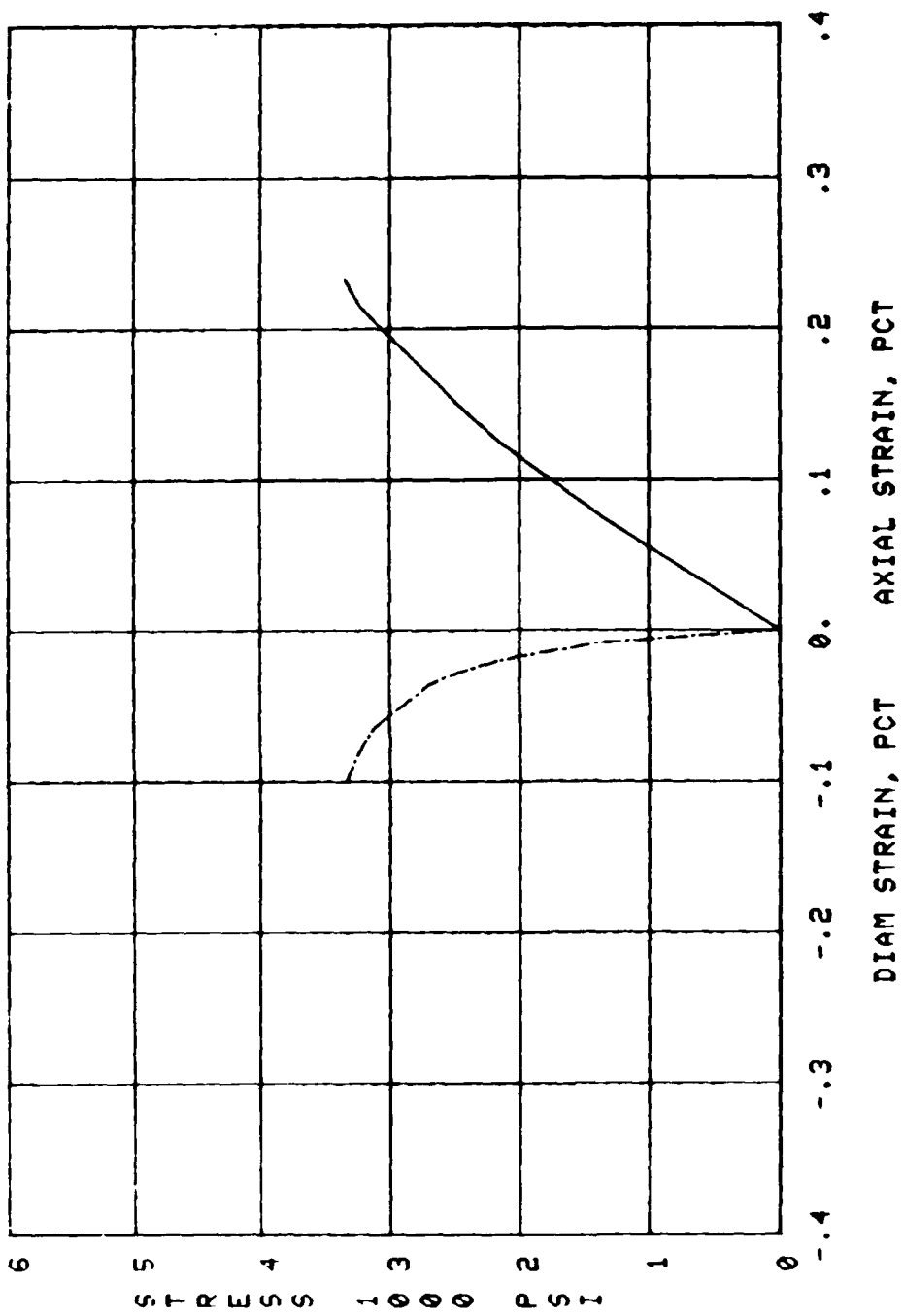

CONCRETE COMPRESSIVE STRESS-STRAIN  
 LOCK & DAM #8, MON RIVER  
 L-13-82, 1.0-2.0  
 AXIAL L-13-82 1.0-2.0  
 DIAM L-13-82 1.0-2.0

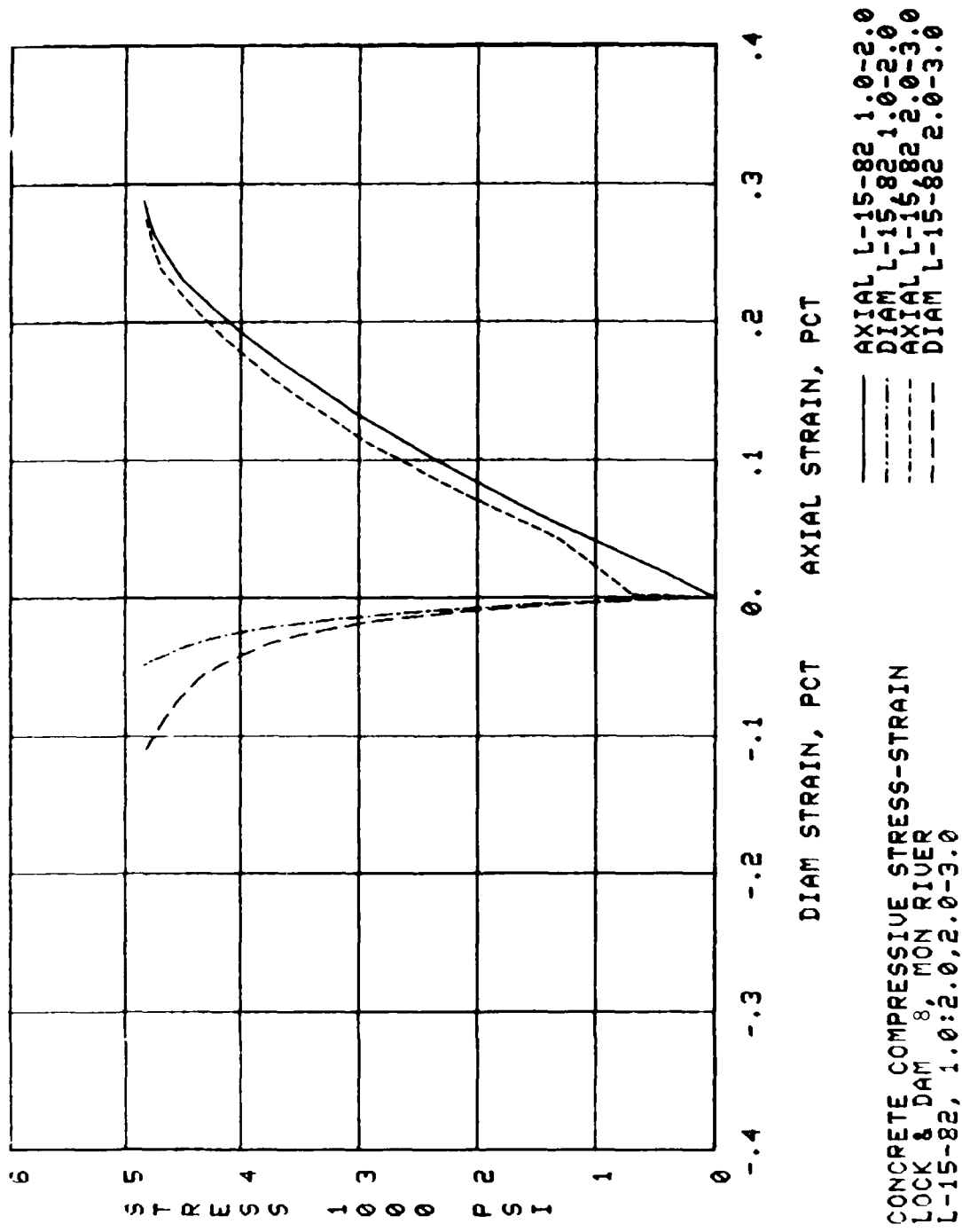

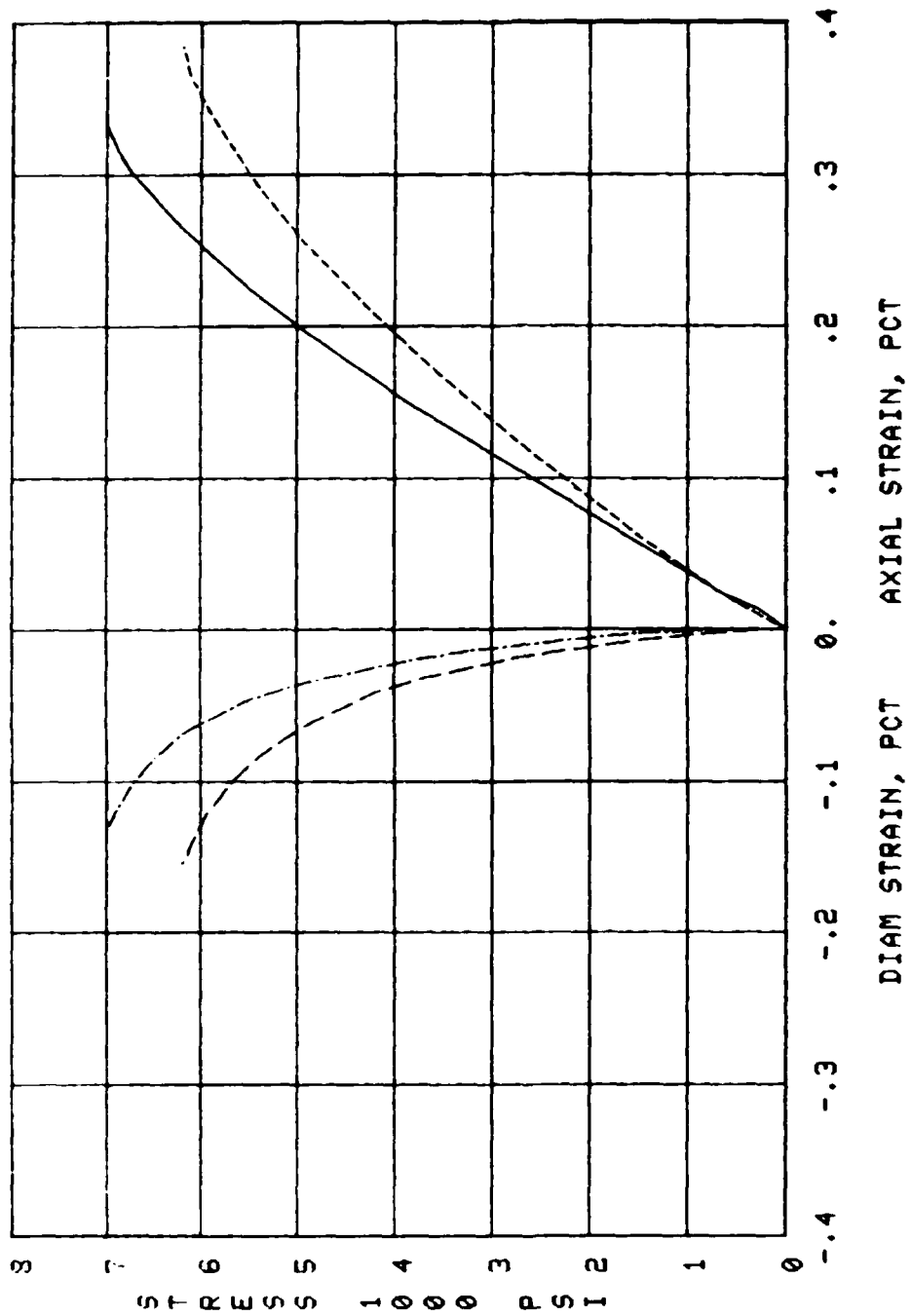

AXIAL L-17-82 2.0-2.8  
 DIAM L-17-82 2.0-2.8  
 AXIAL L-17-82 7.3-8.3  
 DIAM L-17-82 7.3-8.3

CONCRETE COMPRESSIVE STRESS-STRAIN  
 LOCK & DAM  
 MON RIVER  
 L-17-82, 2.0-2.8, 7.3-8.3

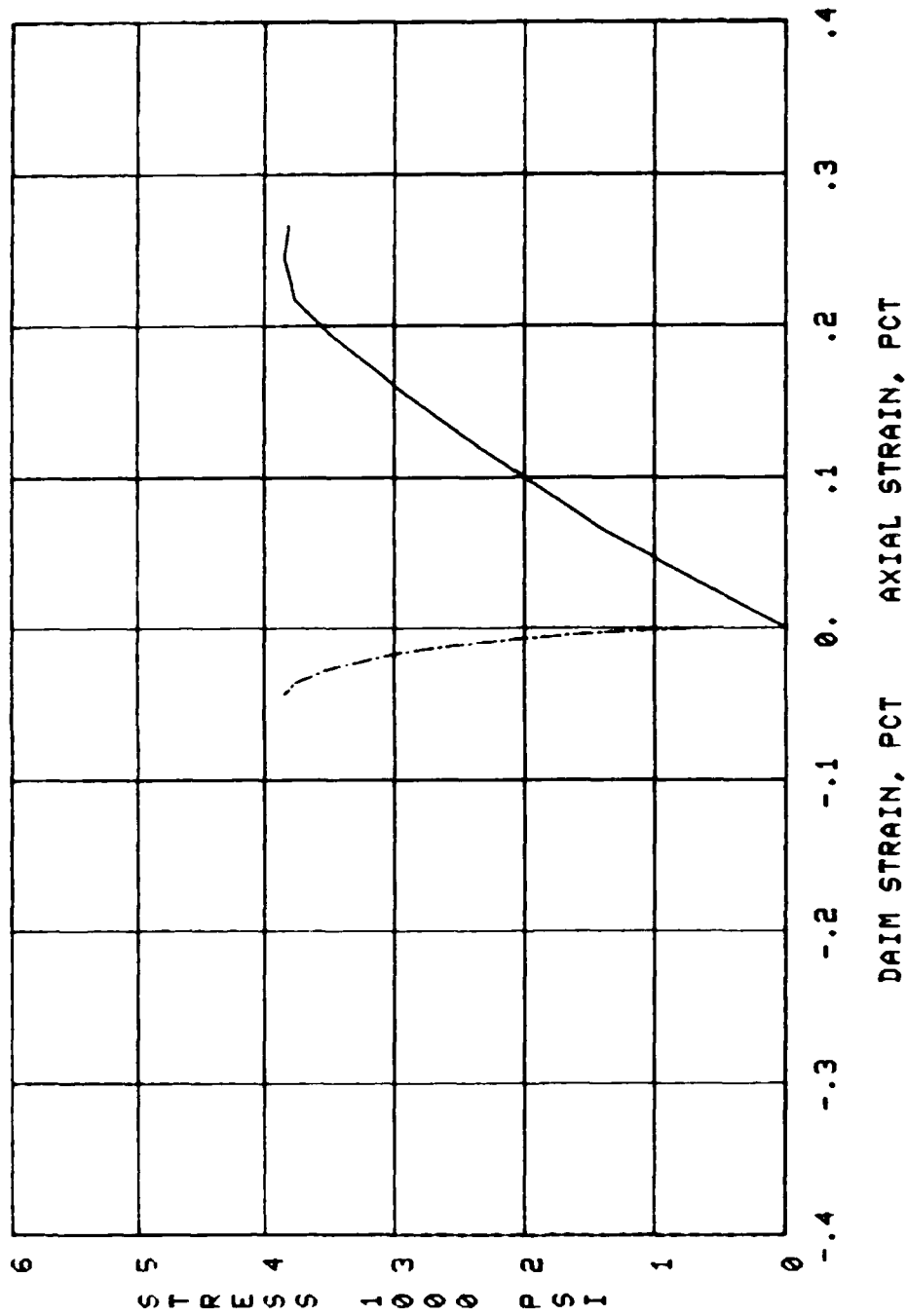

CONCRETE COMPRESSIVE STRESS-STRAIN  
 LOCK & DAM 8, MON RIVER  
 GI-1-82, 0.8-1.8  
 ————— AXIAL GI-1-82 0.8-1.8  
 - - - - - DIAM GI-1-82 0.8-1.8

CONCRETE PROPERTIES  
Lock #8 Mon River

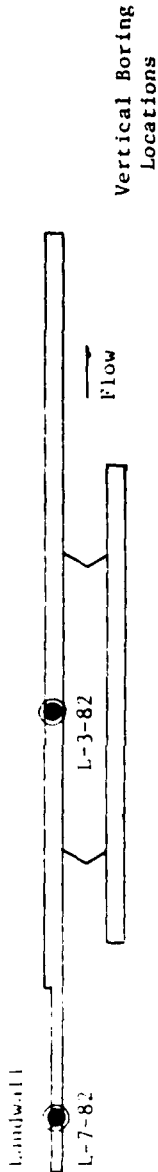

No Scale

Boring No. PM-WES-L-7-82				Boring No. PM-WES-L-3-82				
Elev ft	Depth ft	Leg- end	Material	Unit Wt pcf	Vp fps	Comp Strg psi	E <sup>6</sup> x 10 <sup>6</sup> psi	v
803.1								
798.7			Frost damage 0.5 to 2.5' Paste brown, broken to 3.5'	138.4	12478	5450		
795.2	10.0		Band of dk paste 0.25- 0.4', air- entrained Alkali-silica gel on break surfaces throughout core End boring at 9.0'	139.0	12187	4850		
			Rubble, 0.0' to 2.0' Wht reaction on break sur- faces 0.0 to 1.8' End Boring Frost damage 0.0 to 2.3'					

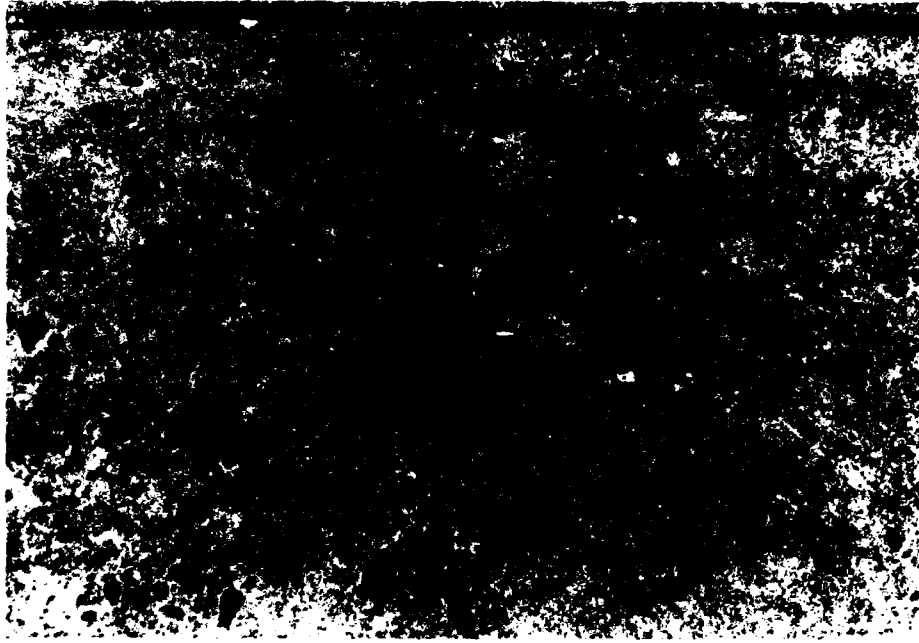

Typical top surface, guide walls



Concrete core, boring L-7-82, 3.6 to 5.3 ft, showing good quality concrete with plus 5000-psi compressive strength



Concrete core, boring L-7-82, overlay concrete, 0.0 to 0.45 ft, missing rubble and cracked concrete to 2.5 ft

CONCRETE PROPERTIES  
Lock #8 Main River

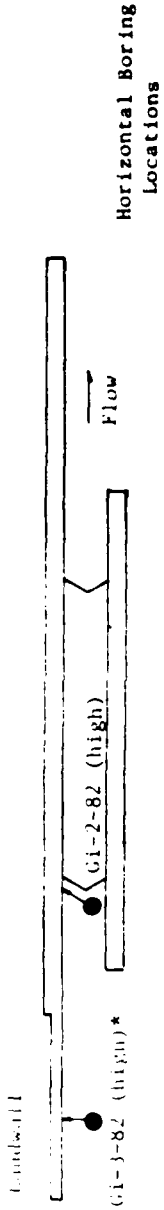

Horizontal Boring Locations

60 Scale

Boring No. PM-WES-GI-3-82				Boring No. PM-WES-GI-2-82														
Elev	Depth ft	Log- end	Material	Unit Wt pcf	Vp fps	Comp Strg psi	F x 10 <sup>6</sup> psi	v	Elev	Depth	Log- end	Material	Unit Wt pcf	Vp fps	Comp Strg psi	F x 10 <sup>6</sup> psi	v	
783.5	1.0		Frost damage 0.0 to 0.35" Surface spalling	143.2	--	4240	--	--	799.8	1.0		Frost damage 0.35 to 3.0" New concrete 0.0-0.3 air-entraine						
	2.0		Alkali-silica gel through- out core							2.0		Alkali-silica gel through- out core						
	3.0		End Boring							3.0		End Boring						

\* 783.5 indicates boring 30 ft. near (above or below) upper pool elevation.  
\* 799.8 indicates boring 30 ft. near (above or below) upper pool elevation.



Horizontal boring Gi-3-82, upper portion upper guide wall



Horizontal boring Gi-2-82, upper miter gate recess, land wall,  
showing broken core to full 3.0-ft depth

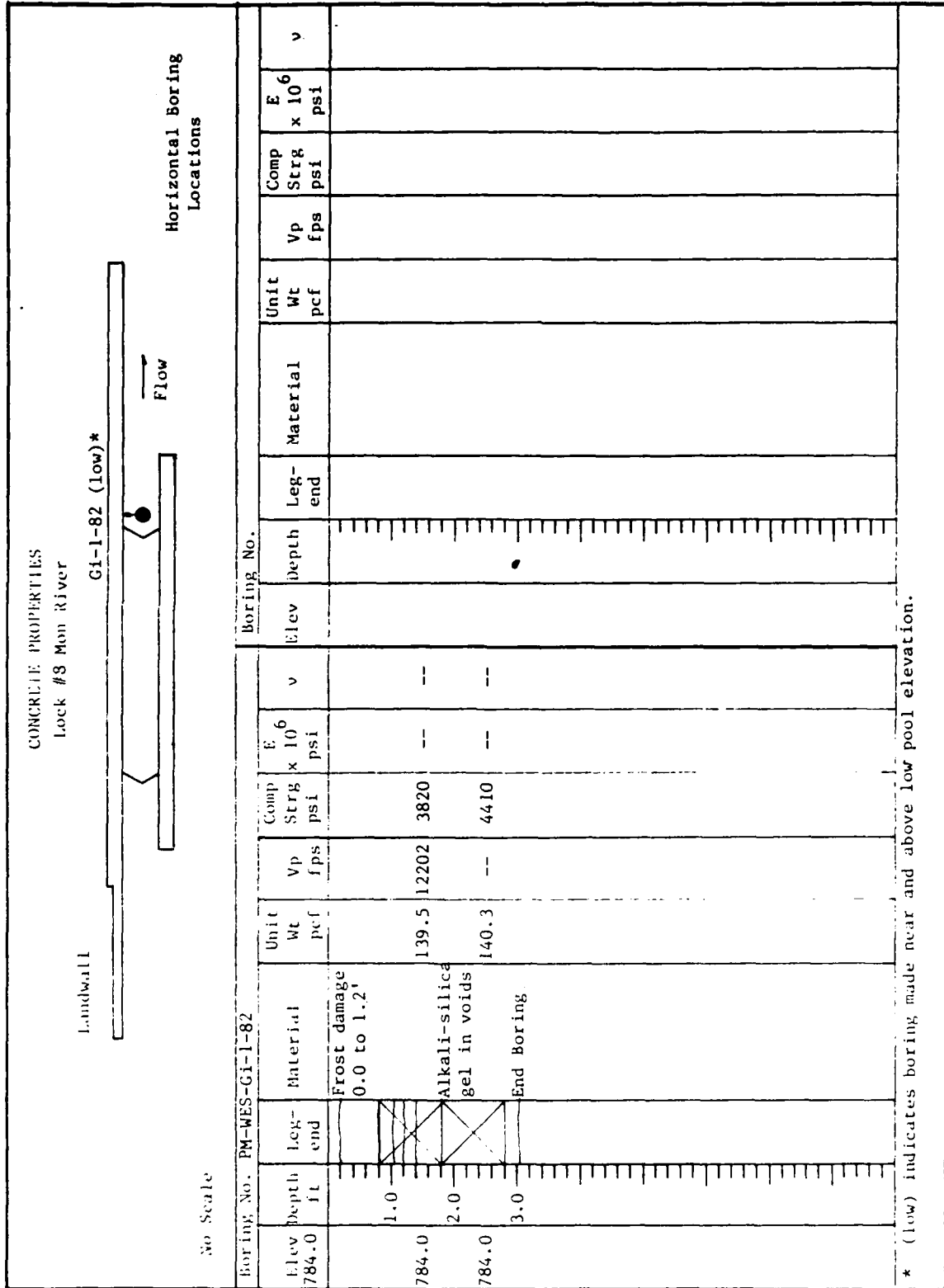

CONCRETE PROPERTIES  
Lock #8 Mon River

Landwall

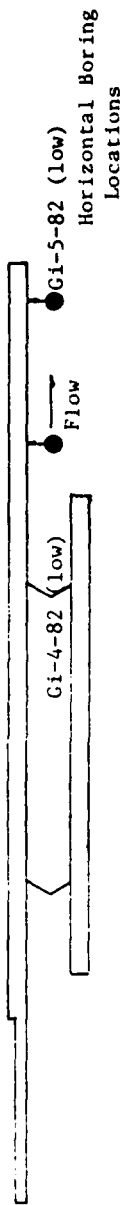

No Scale

Boring No. PM-WES-GI-4-82				Boring No. PW-WES-GI-5-82				
Elev	Depth	Leg- end	Material	Unit Wt pcf	Vp fps	Comp Strg psi	E 6 x 10 <sup>6</sup> psi	v
783.5	1.0		Frost damage 0.0 to 0.9' Surface spalling broken to 0.5'	138.3	--	4540	--	--
783.5	2.0		Alkali-silica gel					
	3.0		End Boring					
782.5	1.0		Const Jt					
782.5	2.0		Const Jt					
			Alkali-silica gel below 2.6'	142.6				
	3.0		End Boring					
						4730		

Note: No core tested.







Concrete core L-11-82, vertical boring, upper guard wall; overlay concrete 0.0 to 0.6 ft;  
broken core interval 0.6 to 3.0 ft



Concrete core L-17-82, vertical boring, lower guard wall; overlay concrete 0.0 to 0.5 ft;  
broken and cracked concrete to 1.6 ft

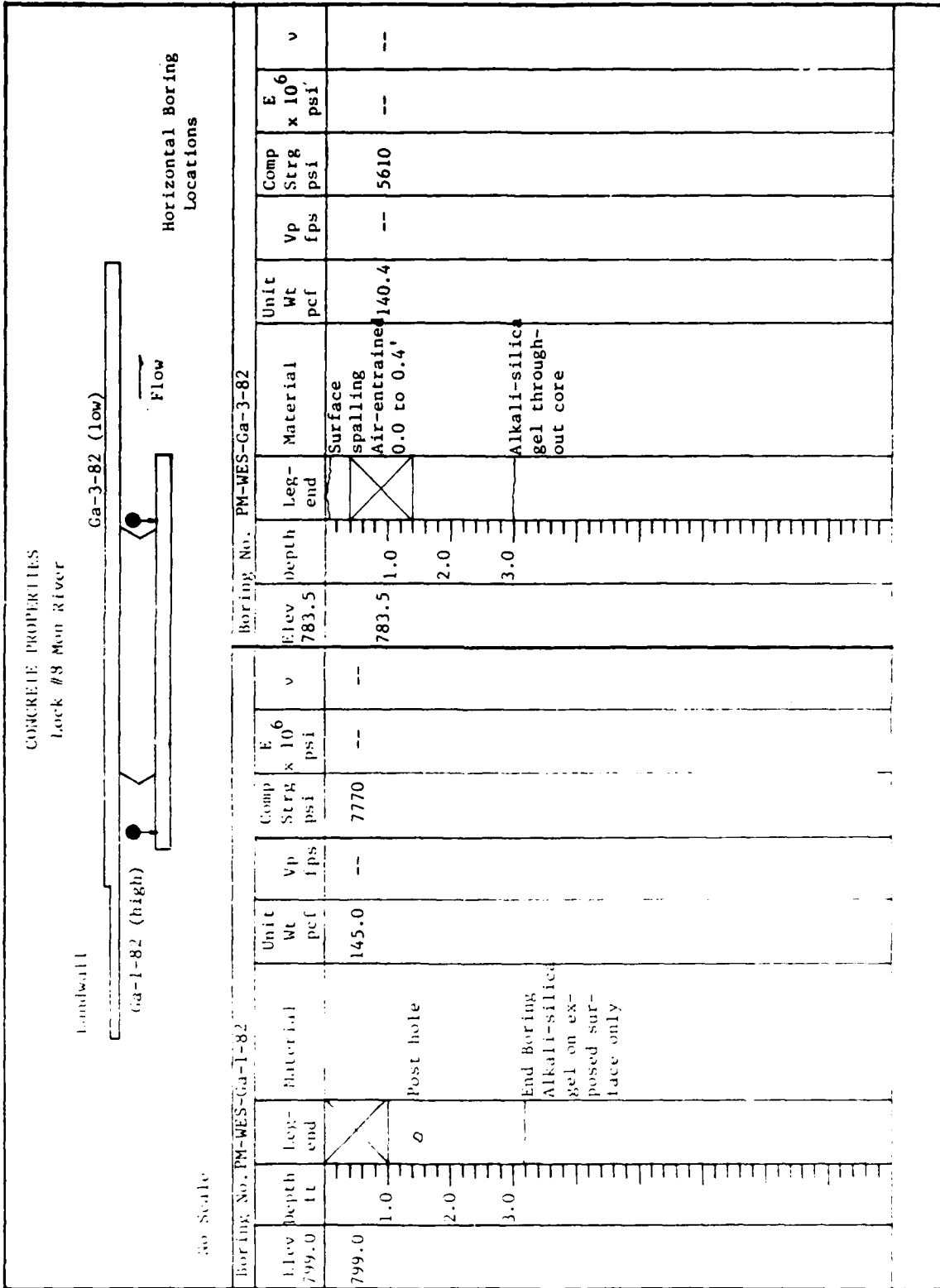



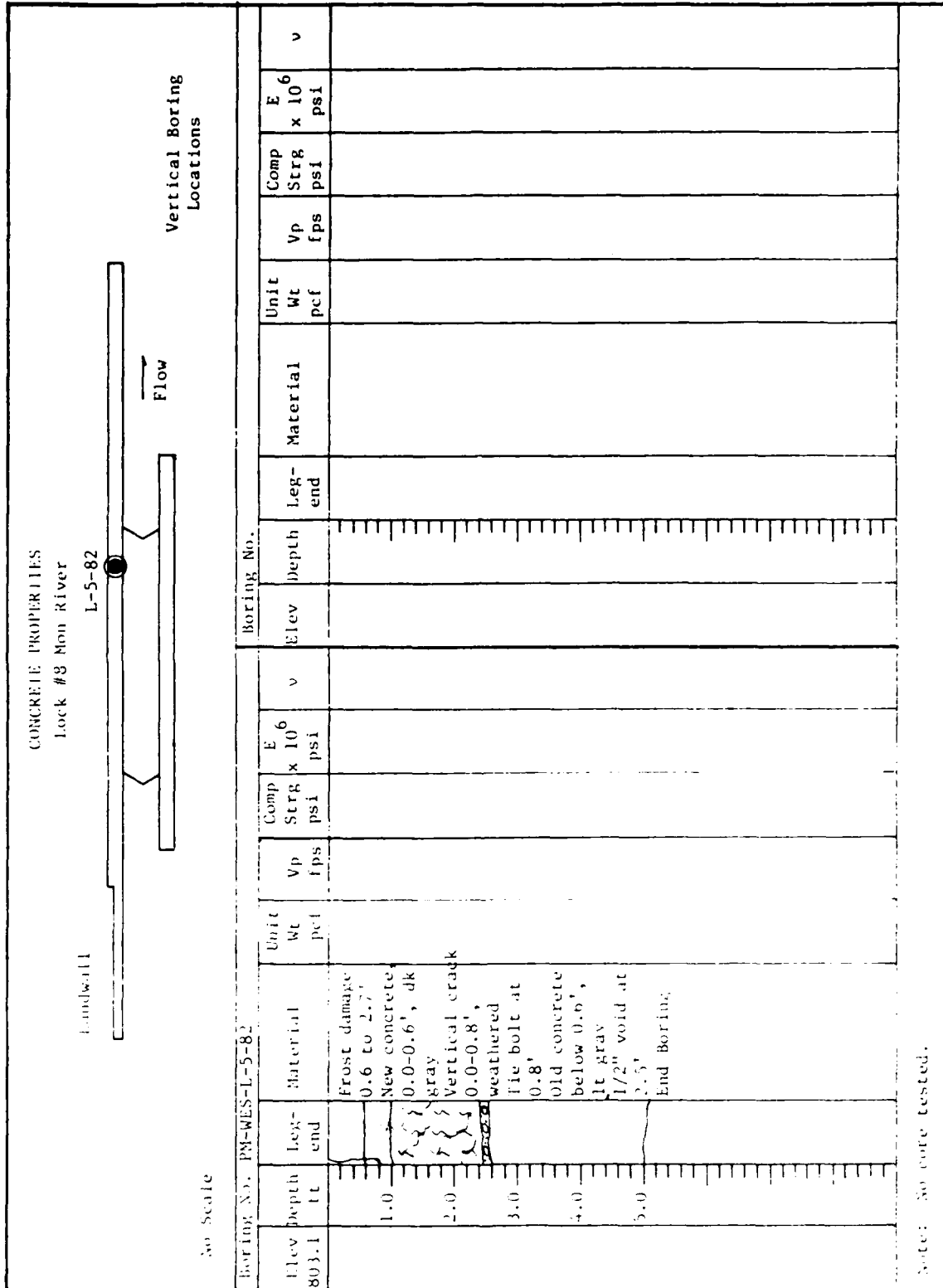



Concrete core, boring L-1-82, vertical boring in land lock wall showing broken concrete to 1.5 ft

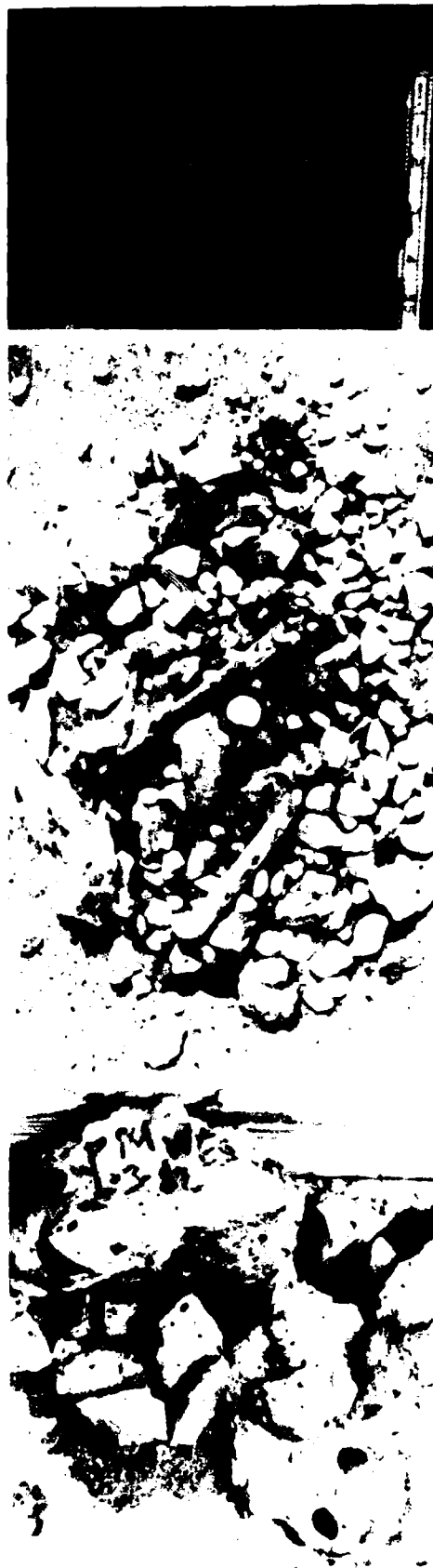

Concrete core, boring L-3-82, vertical boring land lock wall showing rubble and broken core to 2.3 ft. Top of core at left

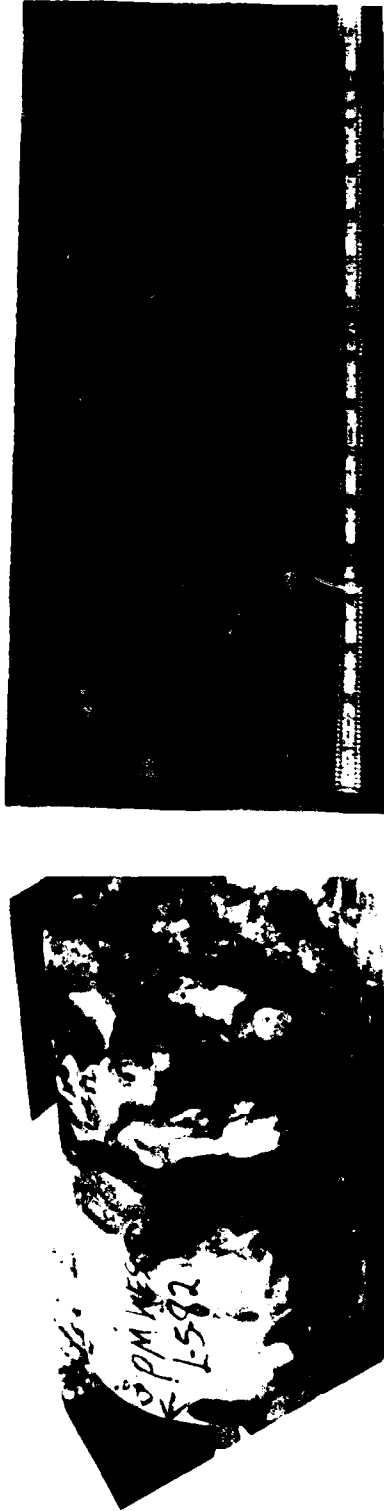

Concrete core, boring L-5-82, vertical boring land lock wall showing overlay and missing core interval from 1.0 to 2.5 ft

CONCRETE PROPERTIES  
Lock #8 Mon River

Landwall

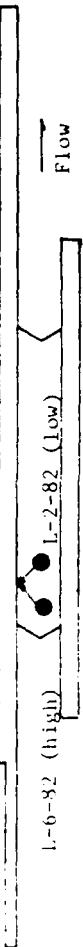

Horizontal Boring  
Locations

30 Scale

Boring No. PM-WES-L-6-82				Boring No. PM-WES-L-2-82				
Elev	Depth	Leg- end	Material	Unit Wt pcf	Vp fps	Comp Strg psi	E $\times 10^6$ psi	v
793.0	1.0	0	Surface smooth 3/4" rebar No alkali- silica gel -End Boring					
	2.0							
783.0	1.0		Frost damage 0.0-0.4'					
	2.0		Wht rxn mtl Alkali- silica gel throughout core -End Boring					
	3.0		Const Jt Surface Spalling					

Note: No test specimens could be obtained.

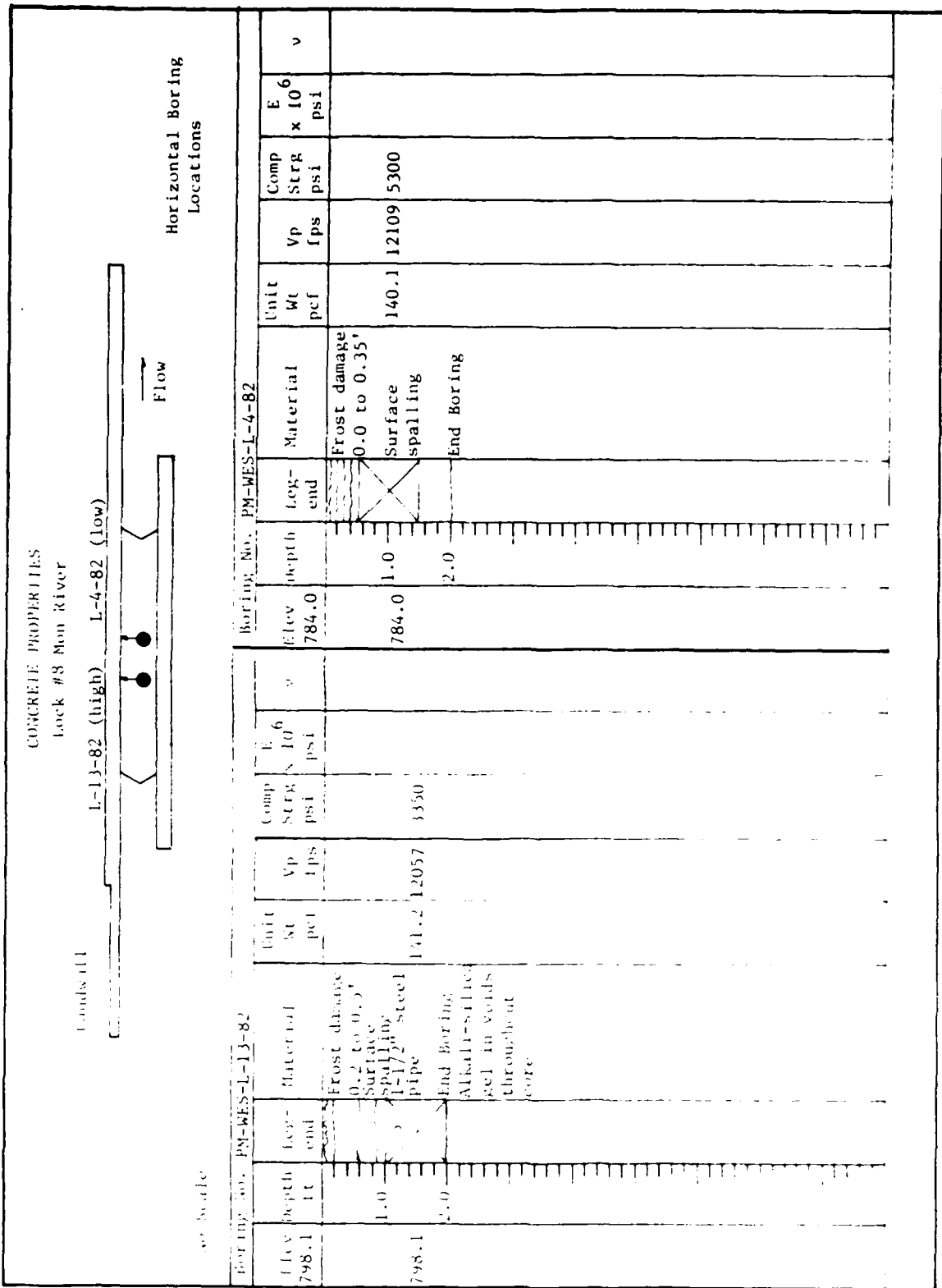
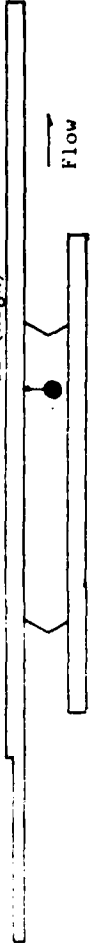

PLATE 70

CONCRETE PROPERTIES  
 Lock #3 Mon River

Landwall

L-14-82 (high)



Horizontal Boring  
 Locations

No scale

Boring No. PM-WES-L-14-82		Boring No.		Boring No.		Boring No.		Boring No.		Boring No.							
Elev	Depth	leg- end	Material	Unit Wt pcf	Vp fps	Comp Strg psi	E x 10 <sup>6</sup> psi	v	Elev	Depth	leg- end	Material	Unit Wt pcf	Vp fps	Comp Strg psi	E x 10 <sup>6</sup> psi	v
792.1																	
	1.0		Frost damage 0.45' to 1.3' New concrete 0.0' to 0.45'														
	2.0		poorly com- pacted End Boring Alkali-silica gel through- out core														

Note: No core tested.

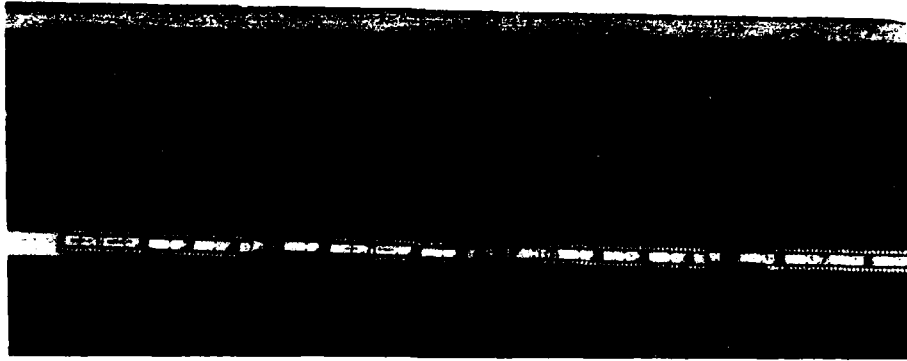

Concrete core, boring L-6-82, high horizontal boring, land lock wall.  
No damage observed



Concrete core boring, L-29-82, high horizontal boring, land lock wall

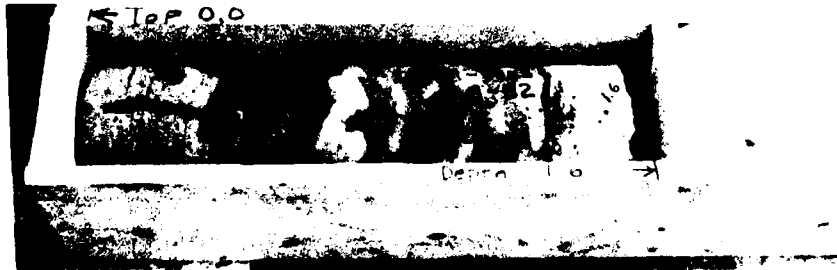

Concrete core, boring L-14-82, high horizontal boring, land lock wall,  
shotcrete overlay 0.0 to 0.5 ft, broken and cracked concrete to 1.3 ft

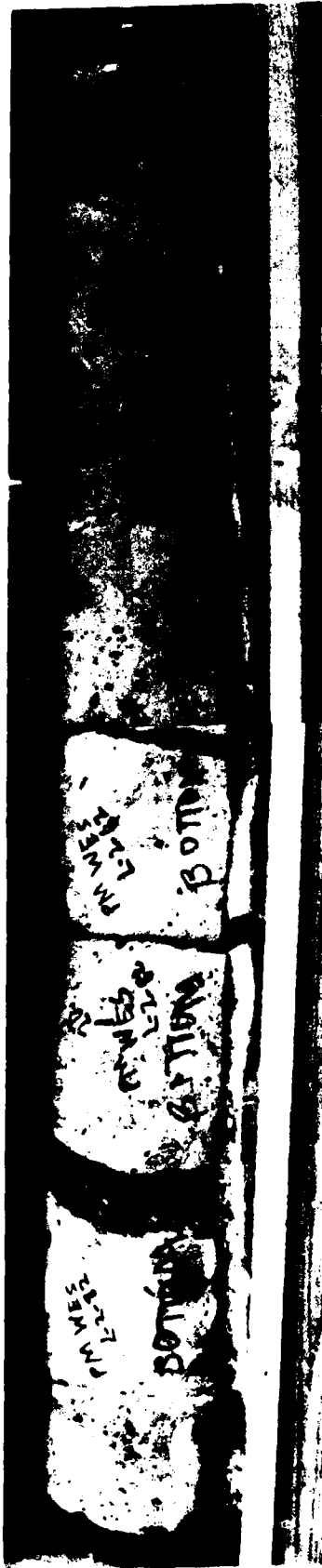

Concrete core, boring L-2-82, low horizontal boring showing frost damage from 0.0 to 0.5 ft. Vertical construction joint. Note white alkali-silica gel on joint and cracks



Concrete core, boring L-4-82, low horizontal boring, damage due to cracking 0.0 to 0.4 ft



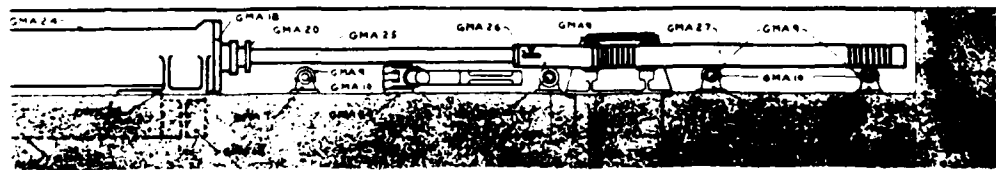
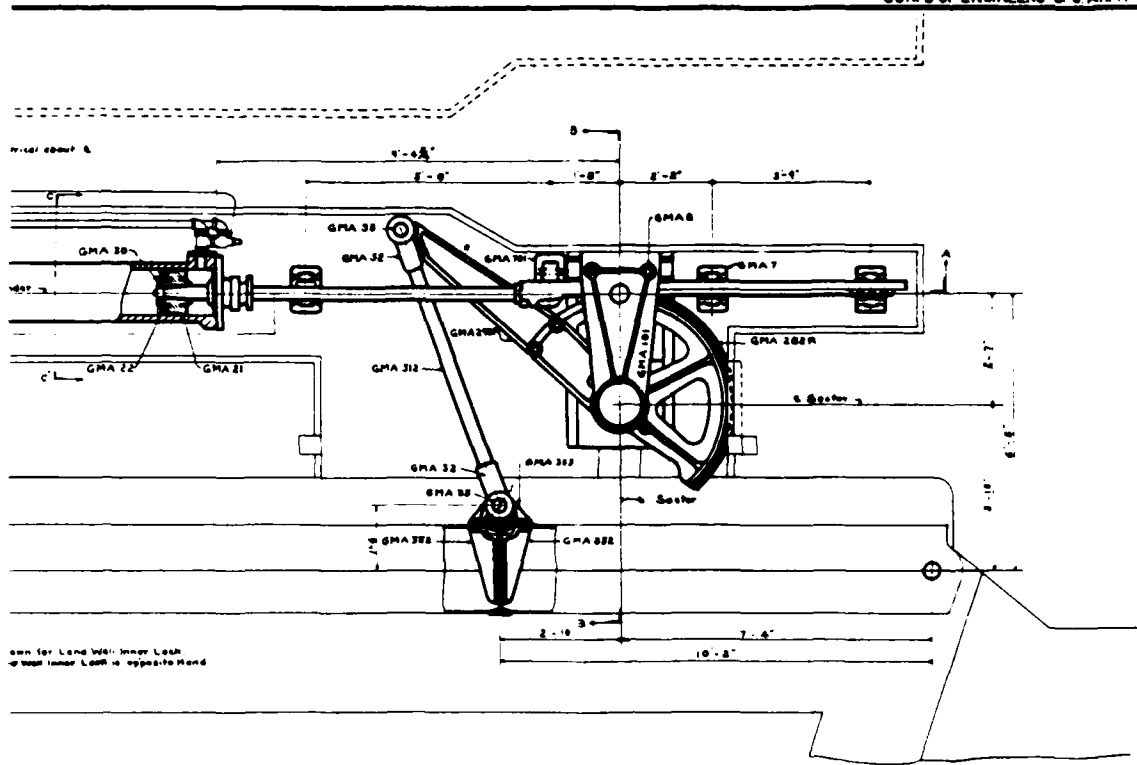

SECTION A-A  
Scale 1/2"=1'-0"

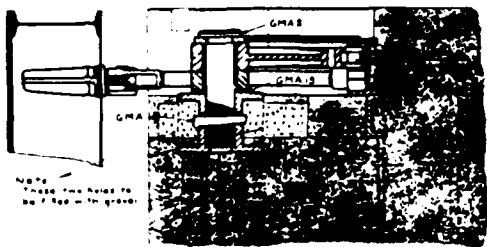

SECTION B-B  
Scale 1/2"=1'-0"

MONONGAHELA RIVER.  
LOCK NO 7 & 8  
GATE OPERATING MACHINERY  
ASSEMBLY

11 OF 11 SHEETS  
SCALE AS SHOWN  
U.S. ENGINEER OFFICE, PITTSBURGH, PA. AUG 6, 1924  
Submitted by \_\_\_\_\_ Approved \_\_\_\_\_  
Checked by \_\_\_\_\_  
Drawn by R.E.Y.  
Traced by S.P.O.C.  
Checked by \_\_\_\_\_  
FILE NO M-73-2

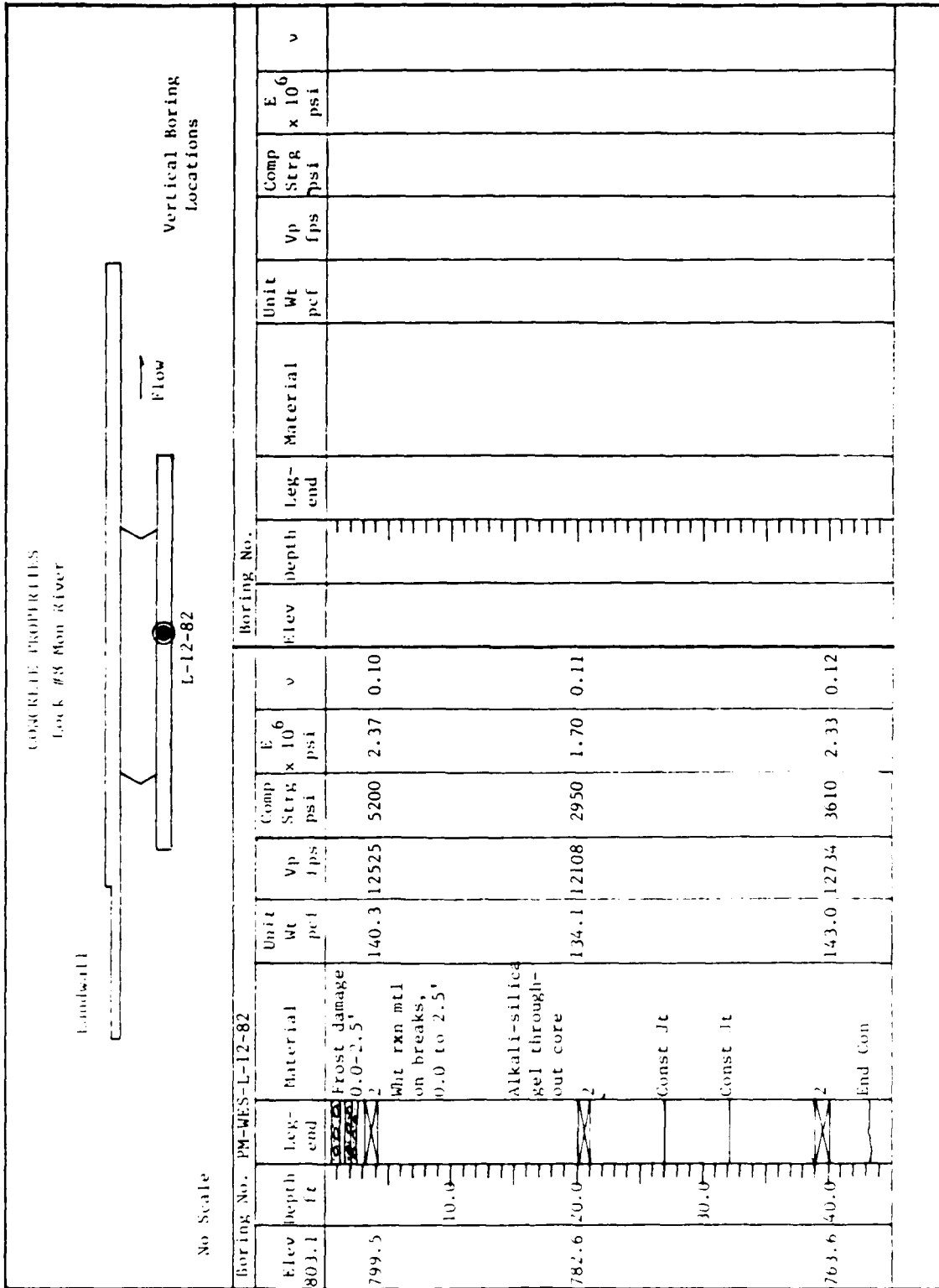



Concrete core, boring L-12-82, vertical boring in river wall.  
Damage concrete to 2.5 ft



Concrete core, boring L-10-82, vertical boring in upper miter gate monolith  
in river wall. No detectable concrete damage

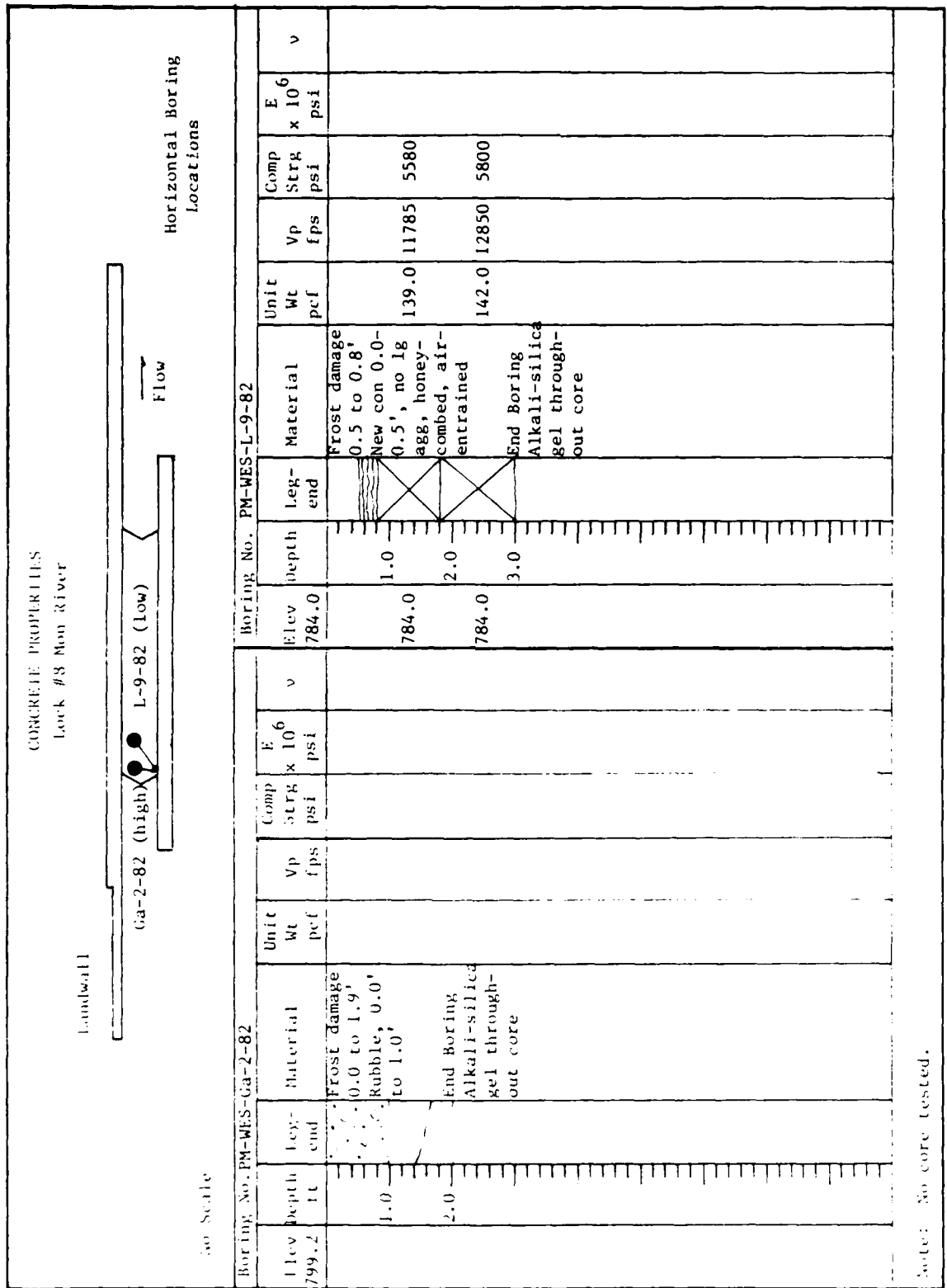



CONCRETE PROPERTIES Lock #8 Main River										
Landwall										
L-16-82 (high)										
Flow										
Horizontal Boring Locations										
So Scale					Boring No.					
Boring No.	Depth ft	Loc-end	Material	Unit Wt pcf	Vp fps	Comp Strg psi	E <sup>6</sup> x 10 <sup>6</sup> psi	Elev	Depth	Loc-end
792.0			Frost damage 0.0 to 0.6'							
792.0	1.0		Surface spalling	143.2	12617	5400				
	2.0		Alkali-silica gel through-out core							
	3.0		End Boring							



Concrete core, boring Ga-2-82, high horizontal boring, river lock wall.  
Note broken and cracked pieces

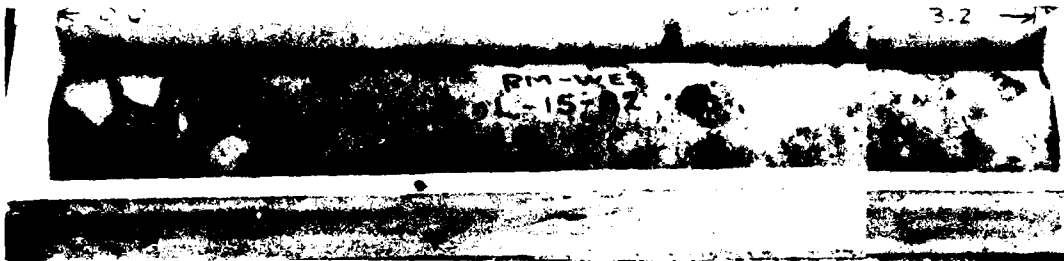

Concrete core, boring L-15-82, high horizontal boring, river lock wall.  
Note cracking to 0.9 ft

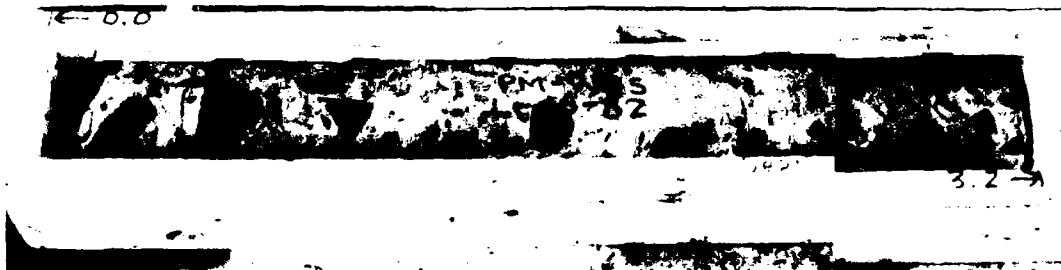

Concrete core, boring L-16-82, high horizontal boring, river lock wall.  
Note cracking to 0.6 ft

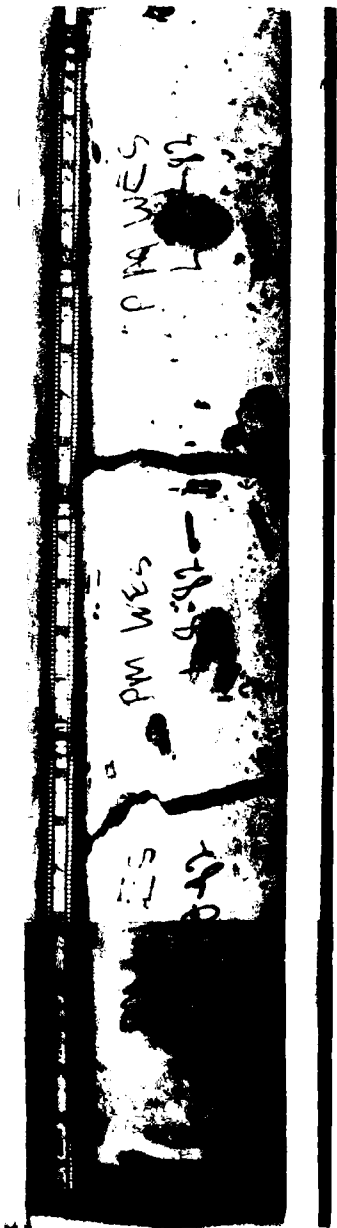

Concrete core, boring L-8-82, low horizontal boring, river lock wall

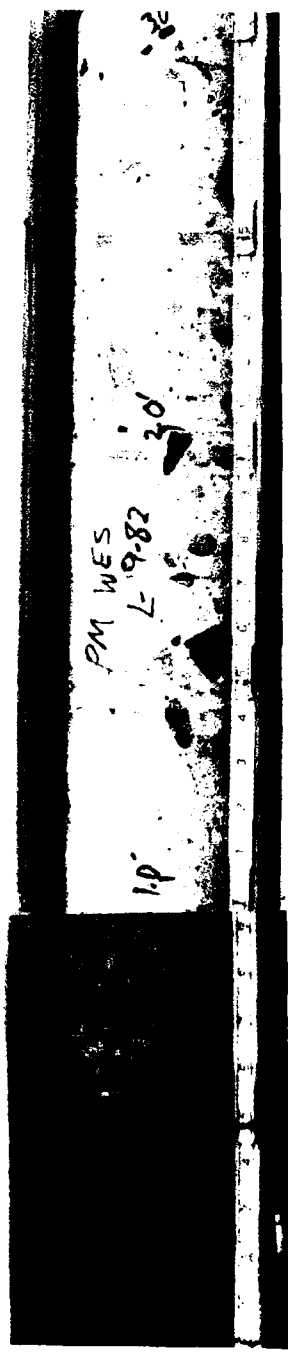

Shotcrete Cracked

Concrete core, boring L-9-82, low horizontal boring, river lock wall

APPENDIX A  
PHOTOGRAPHS OF LOCK NO. 8  
MONONGAHELA RIVER

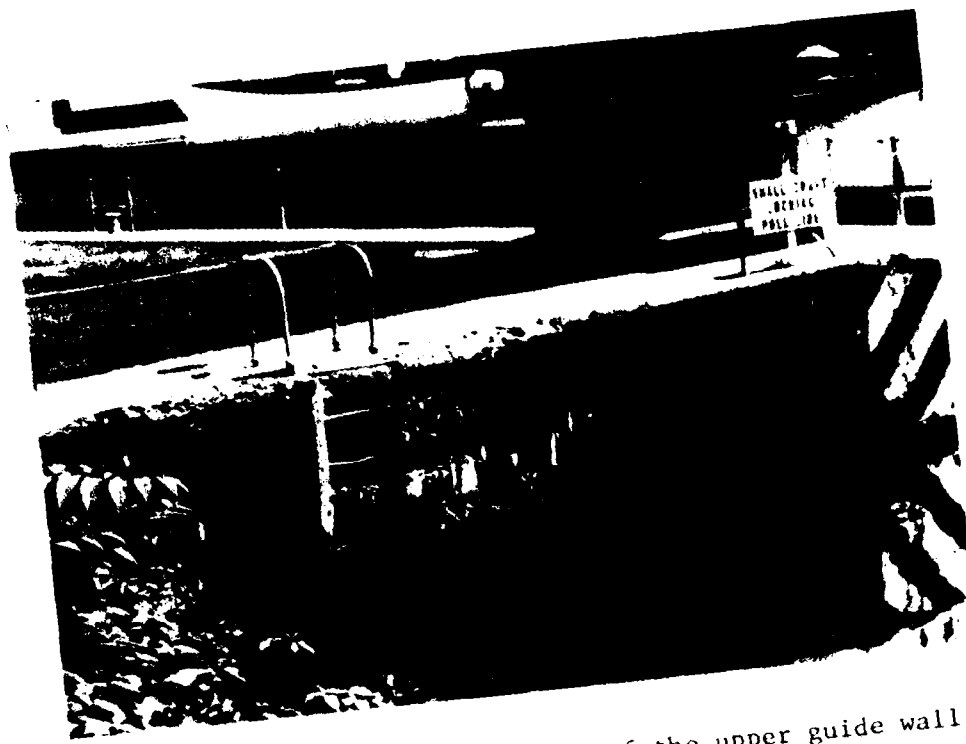

Photo 1. Vertical face of upstream end of the upper guide wall, looking downstream

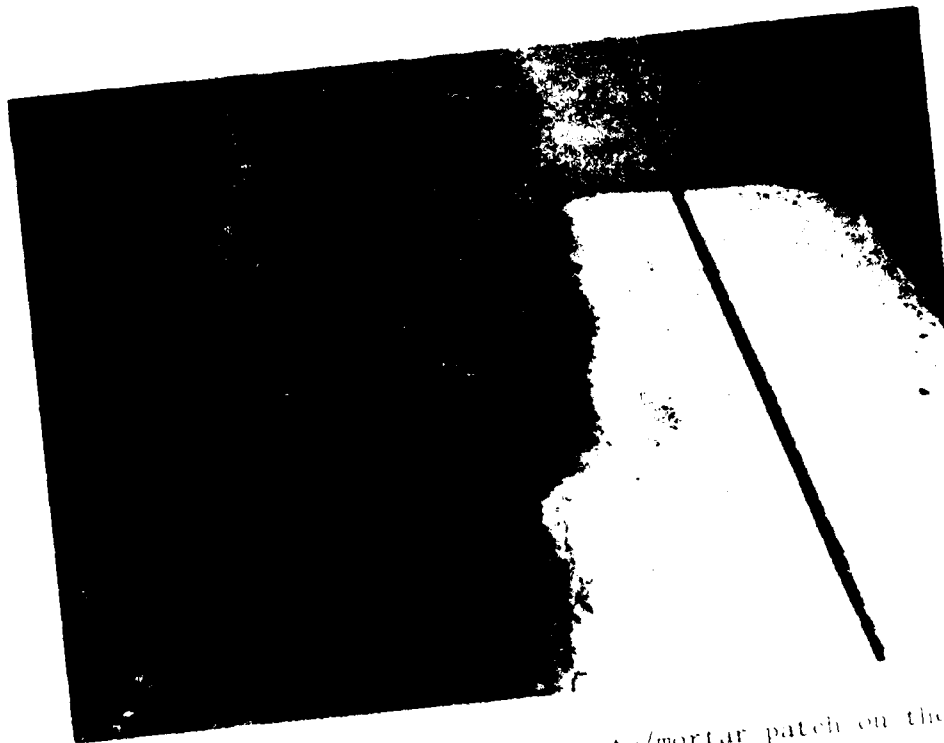

Photo 2. Typical scaling and new concrete/mortar patch on the top surface of the upper guide wall, looking downstream

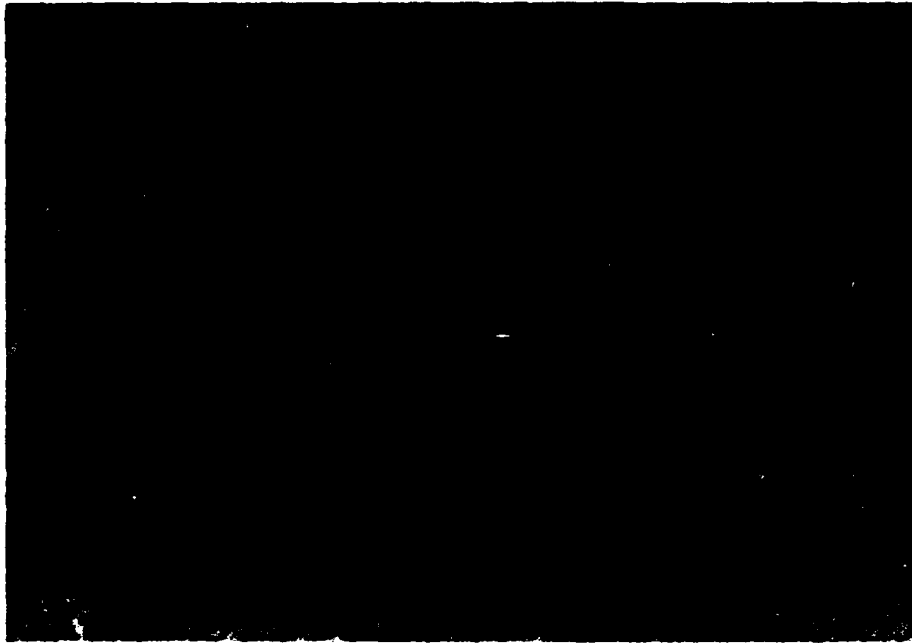

Photo 3. Typical wide transverse crack in top surface of upper guide wall

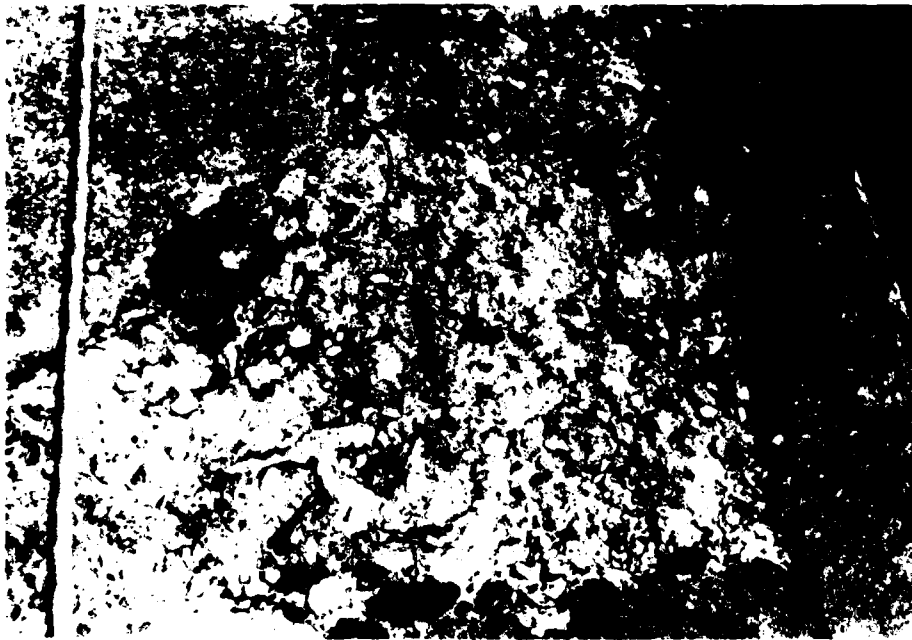

Photo 4. Typical large spall in top of upper guide wall, looking downstream



Photo 5. Typical concrete/mortar patch and small spall at downstream end of upper guide wall, looking downstream



Photo 6. Top surface, lower guide wall, looking downstream



Photo 7. Back side of lower guide wall, shelf in very poor condition, looking downstream

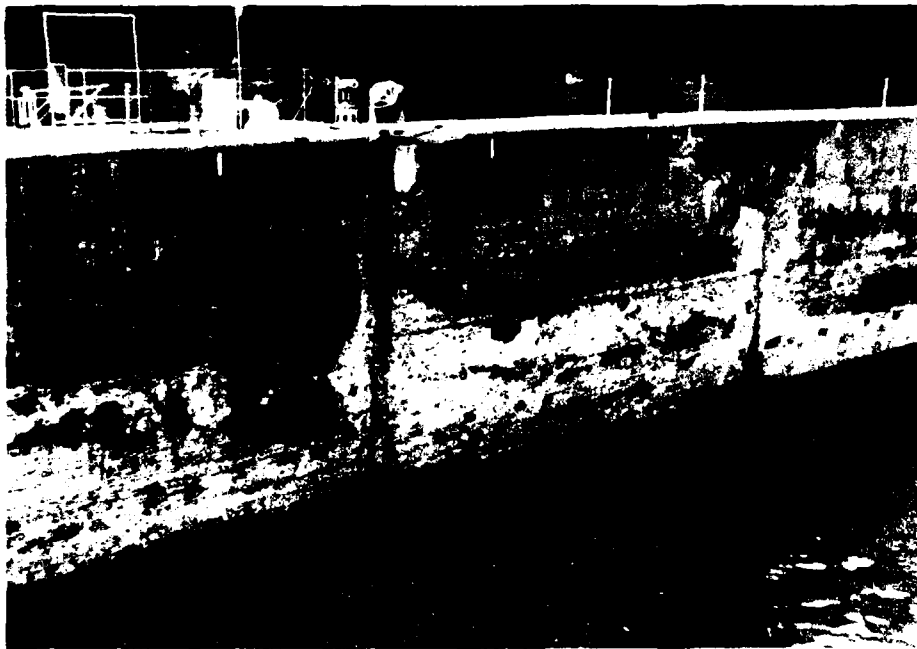

Photo 8. Lower guide wall showing shotcrete removal, construction joint spalls, and scaling, looking downstream from lower guard wall

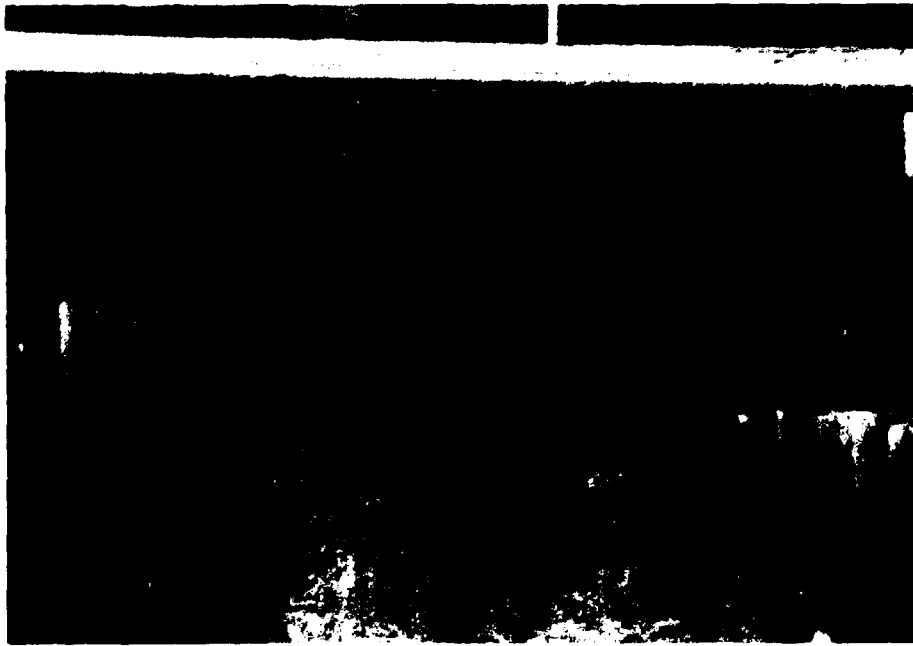

Photo 9. Lower guide wall, close-up spalled area of vertical construction joint, horizontal and diagonal cracking with efflorescence coming from cracks; photo taken from lower guard wall looking landward



Photo 10. Top surface of the lower guard wall, light concrete areas are patches, looking downstream

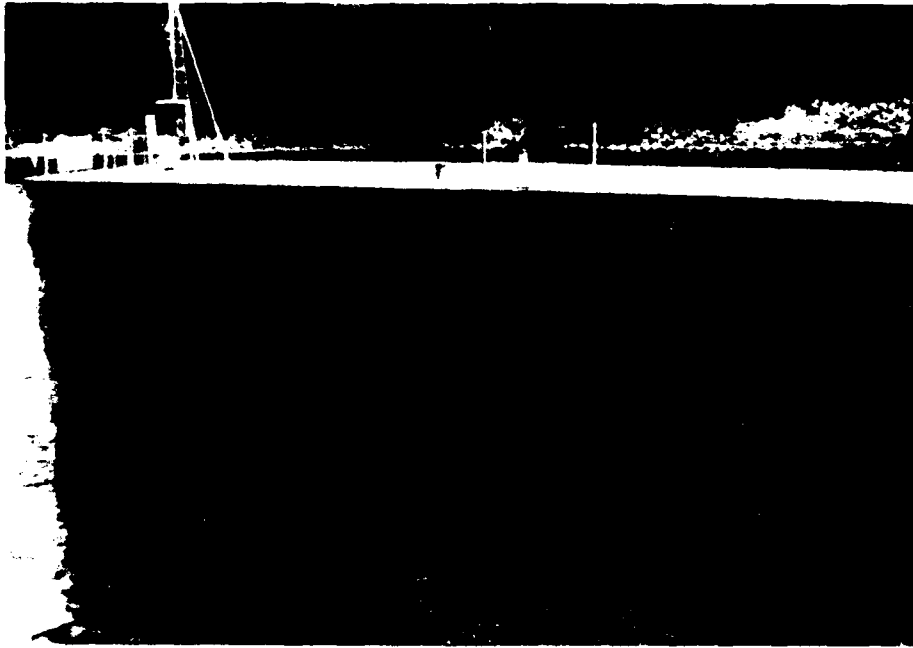

Photo 11. Chamber side face of lower guard wall showing concrete damage, spalling, scaling, cracks, looking downstream and riverward



Photo 12. Chamber side face of lower guard wall, close-up of damage seen in Photo 11

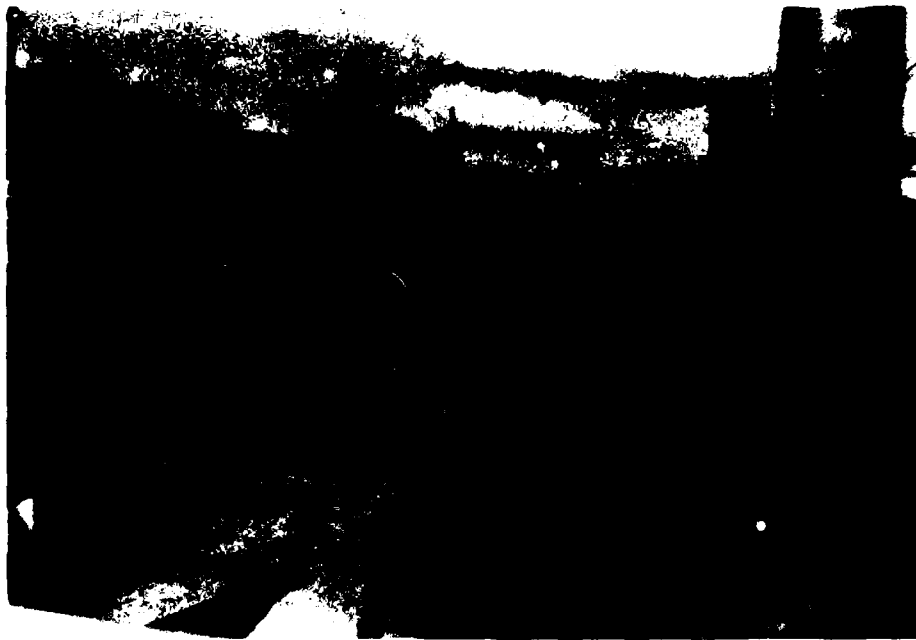

Photo 13. Top surface of land lock wall, looking downstream

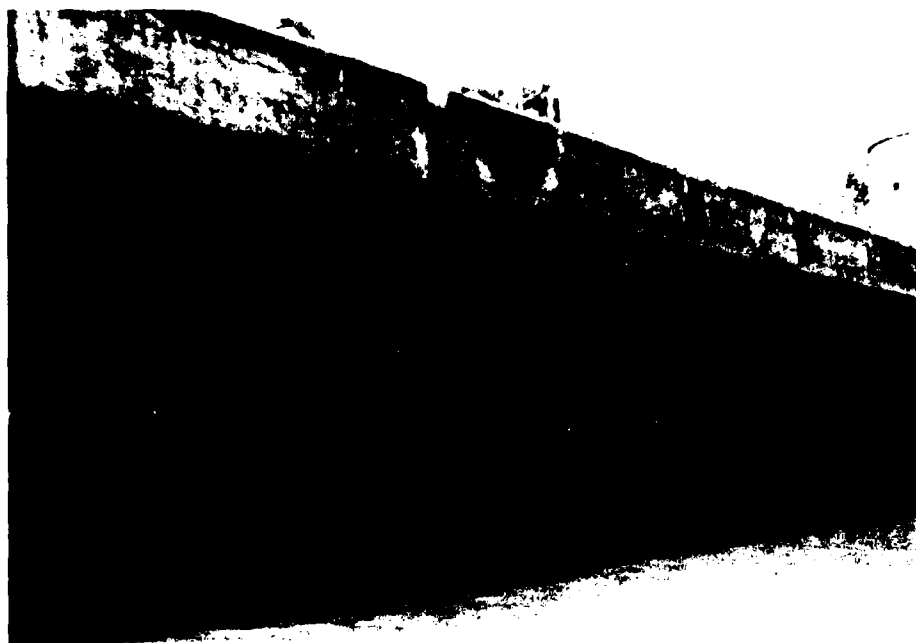

Photo 14. Land lock wall showing scaling, spalling, and areas of missing shotcrete, looking downstream

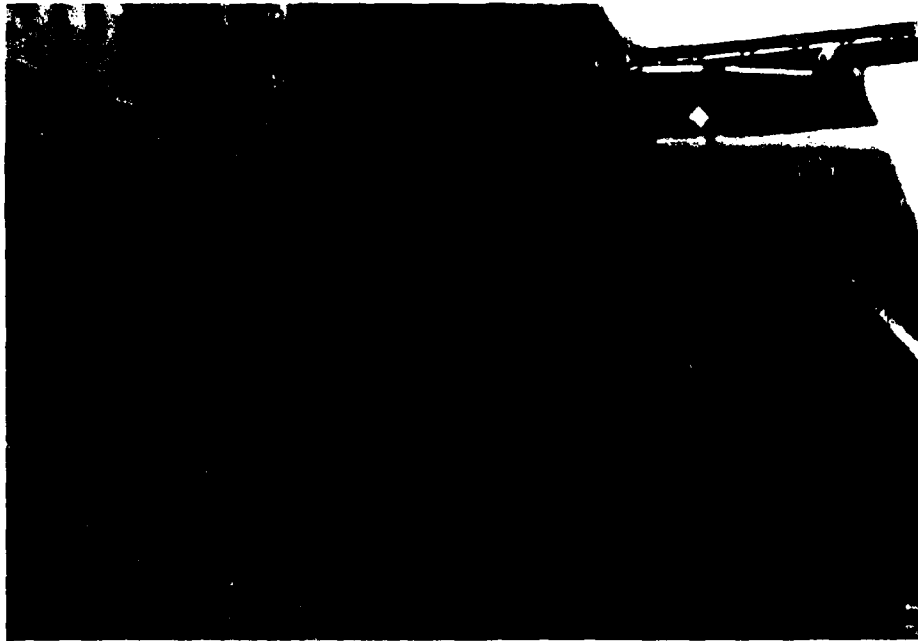

Photo 15. Land lock wall showing exposed wire mesh, areas of missing shotcrete, and exposed large aggregates, looking downstream



Photo 16. River lock wall showing light color concrete/mortar patches and scaling, looking upstream

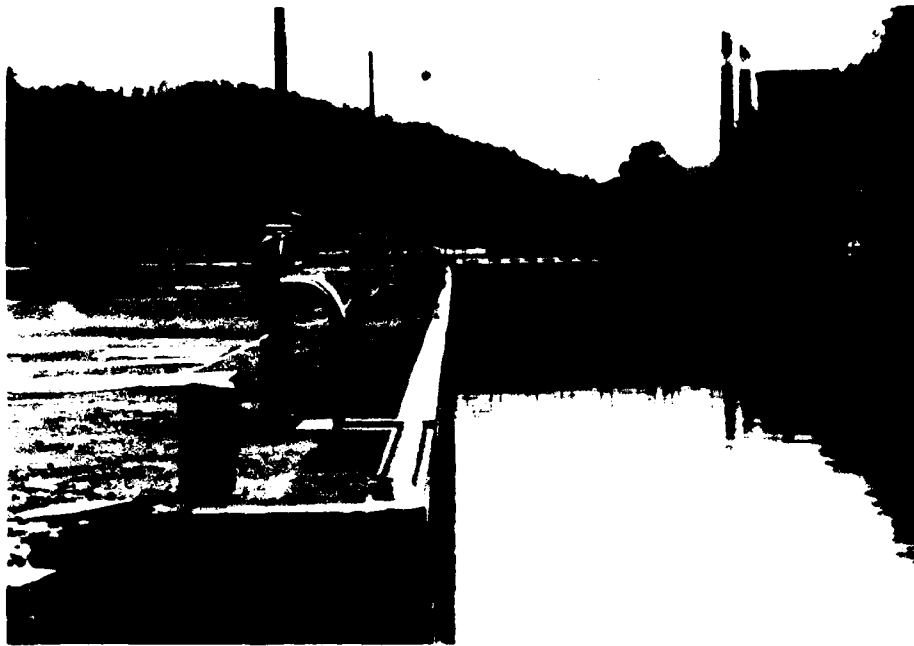

Photo 17. River lock wall showing slight inward bow of the chamber face, looking upstream

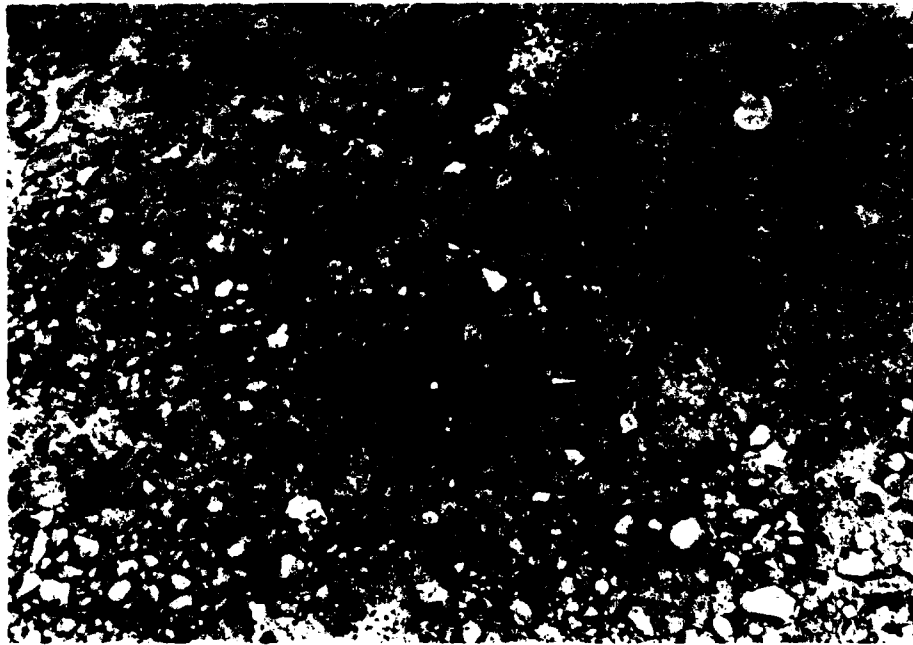

Photo 18. Typical medium scaling on top surface of the river lock wall



Photo 19. River lock wall chamber side showing very severe scaling and spalling; construction joint is spalled to about 12-in. depth, looking riverward



Photo 20. Close-up of left-side portion of Photo 19

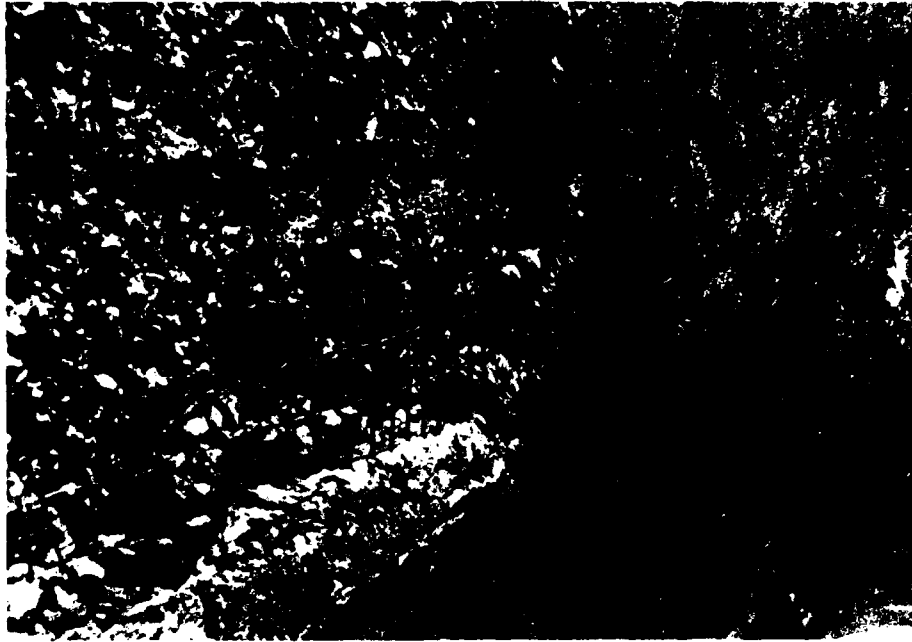

Photo 21. River lock wall showing exposed wire mesh and exposed concrete beneath the shotcrete

APPENDIX B  
FIELD DRILLING LOGS, LOCK NO. 8  
MONONGAHELA RIVER

Field logs for  
Borings PM-WES-L-1-82, L-10-82, and L-12-82

DRILLING LOG		DIVISION		INSTALLATION		SHEET	
Point Marion, PA Lock & Dam #8		Pittsburgh District		L & D #8 Monongahela River		1 OF 2 SHEETS	
1. PROJECT		2. LOCATION (Coordinates or Station)		10. SIZE AND TYPE OF BIT		11. DATUM FOR ELEVATION SHOWN (FIM or MSL)	
3.0' in & 4.0 U.S. of D.S. Monolith joint of upper gate mono-				6" X 7 3/4"		MSL	
4. DRILLING AGENCY		5. HOLE NO. (As shown on drawing title and file number)		12. MANUFACTURER'S DESIGNATION OF DRILL			
CE WES lith land lock wall.		PM WES L-1-82		Falling 43-5A			
6. NAME OF DRILLER		7. THICKNESS OF OVERBURDEN		13. TOTAL NO. OF OVERBURDEN SAMPLES TAKEN		14. TOTAL NUMBER CORE BOXES	
James Knox		concrete 43.1'		N/A		14	
8. DIRECTION OF HOLE		9. DEPTH DRILLED INTO ROCK		15. ELEVATION GROUND WATER		16. DATE HOLE	
<input checked="" type="checkbox"/> VERTICAL <input type="checkbox"/> INCLINED _____ DEG. FROM VERT.		8.3'		778' Lower Pool		STARTED 25 Aug 82 COMPLETED 1 Sept 82	
17. ELEVATION TOP OF HOLE		18. TOTAL CORE RECOVERY FOR BORING		19. SIGNATURE OF INSPECTOR			
803'		96 %		J. Ahlvin			
20. TOTAL DEPTH OF HOLE		51.4'					
ELEVATION	DEPTH	LEGEND	CLASSIFICATION OF MATERIALS (Description)	% CORE RECOVERY	BOX OR SAMPLE NO.	REMARKS (Drilling time, water loss, depth of weathering, etc., if significant)	
803.1	0		CONCRETE	100		Top of well	
	5				1		
	10				2		
	15				3		
	20				4		
	25				5		
	30				6		
	35				7		
	40				8		
	45				9		
	50						

<b>DRILLING LOG</b>	<b>DIVISION</b> Pittsburgh District	<b>INSTALLATION</b> L & D #8 Monongahela River	<b>SHEETS</b> of 2 SHEETS
<b>1. PROJECT</b> Point Marion, PA Lock & Dam #8		<b>10. SIZE AND TYPE OF BIT</b> 6" X 7 3/4" Diamond	
<b>2. LOCATION (Coordinates or Station)</b> Mon R-4, 4' from lock wall, 12' from R-5		<b>11. DATUM FOR ELEVATION BROWN (True or Mean)</b> MSL	
<b>3. DRILLING AGENCY</b> Mobile District - Corps of Engineers		<b>12. MANUFACTURER'S DESIGNATION OF DRILL</b> Falling 43-5A	
<b>4. HOLE NO. (As shown on drawing title and file number)</b> PM WES L-10-82		<b>13. TOTAL NO. OF OVER-BURDEN SAMPLES TAKEN</b>	<b>14. TOTAL NUMBER CORE BORES</b> 22
<b>5. NAME OF DRILLER</b> James Knox & David Bowden		<b>15. ELEVATION GROUND WATER</b> 778' Lower Pool	<b>16. DATE HOLE</b> STARTED 10 Sept 82 COMPLETED 23 Sept 82
<b>6. DIRECTION OF HOLE</b> <input checked="" type="checkbox"/> VERTICAL <input type="checkbox"/> INCLINED _____ DEG. FROM VERT.		<b>17. ELEVATION TOP OF HOLE</b> 803'	<b>18. TOTAL CORE RECOVERY FOR BORING</b> 96.7
<b>7. THICKNESS OF OVERBURDEN</b> concrete 41.4	<b>8. DEPTH DRILLED INTO ROCK</b> 46.1	<b>19. SIGNATURE OF INSPECTOR</b> John Lusher	
<b>9. TOTAL DEPTH OF HOLE</b> 87.5			

ELEVATION a	DEPTH b	LEGEND c	CLASSIFICATION OF MATERIALS (Description) d	% CORE RECOVERY e	BOX OR SAMPLE NO. f	REMARKS (Drilling data, water level, depth of penetration, etc., if significant) g
803.1	0.0		CONCRETE	100		Top of Wall
	2.1			100	1	
	4.6			100	2	
	6.2			100	3	
	10			100	4	
	11.6			100	5	
	13.9			100	6	
	15			100	7	775.2-774.4 Drill water loss
	17.3			100	8	
	20			100	9	
	21.3			100	10	
	25.7			100	11	
	26			100	12	
	32.2			100	13	
	35			100	14	
	40.7		Constant loose	100	15	Bottom of Concrete
798.6	87.5					

ENG FORM 18 36 PREVIOUS EDITIONS ARE OBSOLETE  
MAR 71 (TRANSLUCENT)

PROJECT

HOLE NO.

<b>DRILLING LOG</b>	<b>DIVISION</b> Pittsburgh District	<b>INSTALLATION</b> L & D #8 Monongahela River	<b>SHEET</b> 2
<b>1. PROJECT</b> Point Marion, PA Lock & Dam #8		<b>10. SIZE AND TYPE OF BIT</b> 6" X 7 3/4" Diamond	<b>OF 2 SHEETS</b>
<b>2. LOCATION (Coordinates or Section)</b> Mon R-4, 4' from lock wall, 12' from R-5		<b>11. DAY OF YEAR ELEVATION SHOWN (TODAY OR MSL)</b> MSL	
<b>3. DRILLING AGENCY</b> Mobile District - Corps of Engineers		<b>12. MANUFACTURER'S DESIGNATION OF DRILL</b> Failing 43-5A	
<b>4. HOLE NO. (As shown on drawing note and file number)</b> PM WES L-10-82		<b>13. TOTAL NO. OF OVER-BURDEN SAMPLES TAKEN</b>	<b>UNDISTURBED</b> N/A
<b>5. NAME OF DRILLER</b> James Knox & David Bowden		<b>14. TOTAL NUMBER CORE BOXES</b> 22	<b>UNDISTURBED</b> N/A
<b>6. DIRECTION OF HOLE</b> <input checked="" type="checkbox"/> VERTICAL <input type="checkbox"/> INCLINED _____ DEG. FROM VERT.		<b>15. ELEVATION GROUND WATER</b> 778' Lower Pool	
<b>7. THICKNESS OF CONCRETE</b> concrete 41.4		<b>16. DATE HOLE</b>	<b>STARTED</b> 10 Sept 82
<b>8. DEPTH DRILLED INTO ROCK</b> 46.1		<b>COMPLETED</b> 23 Sept 82	
<b>9. TOTAL DEPTH OF HOLE</b> 87.5		<b>17. ELEVATION TOP OF HOLE</b> 803'	
		<b>18. TOTAL CORE RECOVERY FOR BORING</b> 96.7	
		<b>19. SIGNATURE OF INSPECTOR</b> John Lusher	

ELEVATION	DEPTH	LEGEND	CLASSIFICATION OF MATERIALS (Description)	% CORE RECOVERY	BOX OR SAMPLE NO.	REMARKS (Drilling time, water loss, depth of weathering, etc., if significant)
741.6	41.4	XXXX	Soft, gray INDURATED CLAY	100	11	- Bottom of Concrete
	44	XXXX	Mod hard	75	12	
751.1	50.2	XXXX	Mod hard, gray SILTSTONE	100		
754.6	53.7	XXXX	Mod hard, gray SILTSTONE	100	13	
758.2	57.3	XXXX	Mod hard, gray INDURATED CLAY	100	14	
	60.7	XXXX	Soft			742.3 Weak. S. int.
	63.4	XXXX	Soft to mod hard	76	15	
	66.7	XXXX		100	16	
722.2	64.8	XXXX	COAL		17	734.5-724.2 - Broken
731.2	73.8	XXXX	Soft to mod hard, gray INDURATED CLAY	93	18	
	77.6	XXXX	Mod hard, gray SILTSTONE, silty	100	19	
	80.7	XXXX		100	20	
	83.7	XXXX		100	21	
	87.5	XXXX		100	22	- P. Bottom of Hole

<b>DRILLING LOG</b>		<b>DIVISION</b> Pittsburgh District	<b>INSTALLATION</b> L & D #8 Monogahela River	<b>SHEET</b> OF 2 SHEETS
1. PROJECT Point Marion, PA Lock & Dam #8		10. SIZE AND TYPE OF BIT 6" X 7 3/4" Diamond		
2. LOCATION (Coordinates or Station) Monolith R-10.3.5' from lock wall & 1.7'		11. DAYON FOR ELEVATION SHOWN (Type or MSL) MSL		
3. DRILLING AGENCY Mobile District - Corps of Engineers		12. MANUFACTURER'S DESIGNATION OF DRILL Falling 43-5A		
4. HOLE NO. (As shown on drawing title and file number) PM WES L-12-82		13. TOTAL NO. OF OVER-BURDEN SAMPLES TAKEN N/A	DISTURBED N/A	UNDISTURBED N/A
5. NAME OF DRILLER David Bowden and James Knox		14. TOTAL NUMBER CORE BOXES 19		
6. DIRECTION OF HOLE <input checked="" type="checkbox"/> VERTICAL <input type="checkbox"/> INCLINED _____ DEG. FROM VERT.		15. ELEVATION GROUND WATER 778.0' Lower Pool		
7. THICKNESS OF OVERBURDEN concrete 43.6'		16. DATE HOLE STARTED 27 Sept 82 COMPLETED 30 Sept 82		
8. DEPTH DRILLED INTO ROCK 37.9'		17. ELEVATION TOP OF HOLE 803'		
9. TOTAL DEPTH OF HOLE 81.5'		18. TOTAL CORE RECOVERY FOR BORING 99 %		
		19. SIGNATURE OF INSPECTOR John Lusher		

ELEVATION a	DEPTH b	LEGEND c	CLASSIFICATION OF MATERIALS (Description) d	% CORE RECOVERY e	BOX OR SAMPLE NO. f	REMARKS (Drilling time, water level, depth of weathering, etc., if significant) g
803.0	0.0					Top of Wall
	2.5		CONCRETE	100		
	4.9			100	1	
	9.7			100	2	
	14.4			100	3	
	19.1			100	4	
	24.2			100	5	
	29.1			100	6	
	34.2			96	7	
	37.9			100	8	no loss 37.9-47.0
	81.5				19	Bottom of Section

<b>DRILLING LOG</b>		<b>DIVISION</b> Pittsburgh District	<b>INSTALLATION</b> L & D #8 Monongahela River		<b>SHEET 2</b> OF 2 SHEETS
<b>1. PROJECT</b> Point Marion, PA Lock & Dam #8			<b>10. SIZE AND TYPE OF BIT</b> 6" X 7 3/4" Diamond		
<b>2. LOCATION (Coordinates or Station)</b> Monolith R-10, 3.5' from lock wall & 1.7'			<b>11. DATUM FOR ELEVATION SHOWN (TBM or BSL)</b> MSL		
<b>3. DRILLING AGENCY</b> Mobile District - Corps of Engineers			<b>12. MANUFACTURER'S DESIGNATION OF DRILL</b> Falling 43-5A		
<b>4. HOLE NO. (As shown on drawing title and file number)</b> PM WES L-12-82			<b>13. TOTAL NO. OF OVER-BURDEN SAMPLES TAKEN</b>		<b>14. TOTAL NUMBER CORE BOXES</b> 19
<b>5. NAME OF DRILLER</b> David Bowden and James Knox			<b>15. ELEVATION GROUND WATER</b> 778.0' Lower Pool		<b>16. DATE HOLE</b> STARTED 27 Sept 82 COMPLETED 30 Sept 82
<b>6. DIRECTION OF HOLE</b> <input checked="" type="checkbox"/> VERTICAL <input type="checkbox"/> INCLINED _____ DEG. FROM VERT.			<b>17. ELEVATION TOP OF HOLE</b> 803'		
<b>7. THICKNESS OF OVERBURDEN</b> concrete 43.6'			<b>18. TOTAL CORE RECOVERY FOR BORING</b> 99 %		
<b>8. DEPTH DRILLED INTO ROCK</b> 37.9'			<b>19. SIGNATURE OF INSPECTOR</b> John Lusher		
<b>9. TOTAL DEPTH OF HOLE</b> 81.5'					

ELEVATION	DEPTH	LEGEND	CLASSIFICATION OF MATERIALS (Description)	% CORE RECOVERY	BOX OR SAMPLE NO.	REMARKS (Drilling time, cost or loss, depth of weathering, etc., if significant)
763						
752.8	43.6		Soft, gray, silty sand	100		- Bottom of Concrete
	44.0		INDURATED CLAY			
	42.6		Med hard	100		755.8 - 755.7 Silty sandstone gray
752.8	52.7		Med hard to hard, gray SILTSTONE, clayey	100		
747.1	53.7		Med hard, medium gray INDURATED CLAY	100		
	58.5		Soft	100		
	61.4			100		
	64.7			100		
736.6	66.4					
736.5	66.5		Med. gray, very fine grain SANDSTONE			
734.6	68.4					
	68.5		COAL	100		
721.5	70.5		Soft to med hard, gray slightly weathered INDURATED CLAY	100		
725.7	75.3		Silty			
747.3	75.7		Hard, gray SILTSTONE, clayey	100		
	76.0			100		
721.5	81.5			100		Bottom of Hole

APPENDIX C  
CONCRETE PETROGRAPHIC REPORT, LOCK NO. 8  
MONONGAHELA RIVER

## Samples

1. Portions of concrete core from six vertical cores and twelve horizontal cores from Lock and Dam No. 8 were selected for detailed petrographic examination. The cores were 6 in. in diameter, with the exception of L-18-82, which was a 4-in.-diameter core. The cores identified below are samples examined in detail. Other cores that were logged are described elsewhere.

<u>Structures Laboratory (SL) Serial No.</u>	<u>Field Identi- fication No.</u>	<u>Description</u>
PITT-10 CON-1a-11b	L-1-82	Vertical core on land lock wall in upper gate monolith. Samples taken from 0.0-0.3 ft, 2.7-4.0 ft, 22.0-23.1 ft, and 37.1-39.0 ft.
PITT-10 CON-17a-18b	L-5-82	Vertical core on land lock wall near lower gate monolith. Samples taken from 0.0-0.6 ft, 2.7-3.1 ft, and 4.6-5.1 ft.
PITT-10 CON-20a-22	L-7-82	Vertical core on upper guide wall. Samples taken from 0.0-0.25 ft, 5.0-5.3 ft, 7.3-7.9 ft, and 8.0-9.0 ft.
PITT-10 CON-24	L-9-82	Horizontal core on river lock wall 19 ft from top of wall, near upper gate monolith. Sample taken from 0.0-0.8 ft.
PITT-10 CON-25-35	L-10-82	Vertical core on river lock wall in upper gate monolith. Samples taken from 2.0-2.1 ft, 7.2-7.6 ft, 13.9-16.6 ft, 18.5-19.7 ft, and 36.2-37.4 ft.
PITT-10 CON-36-46	L-12-82	Vertical core on river lock wall between upper and lower gate monoliths. Samples taken from 1.2-1.8 ft, 2.4-3.0 ft, 4.5-5.7 ft, 19.1-20.0 ft, and 41.7-42.8 ft.
PITT-10 CON-47	L-13-82	Horizontal core on land lock wall between upper and lower gate recesses, 5 ft down. Sample taken from 0.0-1.0 ft.

<u>Structures Laboratory (SL) Serial No.</u>	<u>Field Identification No.</u>	<u>Description</u>
PITT-10 CON-48	L-14-82	Horizontal core on land lock wall, 11 ft down, near lower gate recess. Sample taken from 0.5-1.6 ft.
PITT-10 CON-49	L-15-82	Horizontal core on river lock wall, 5 ft down, between upper and lower gate recesses. Sample taken from 0.6-1.0 ft.
PITT-10 CON-50	L-16-82	Horizontal core on river lock wall, 11 ft down, near lower gate recess. Sample taken from 0.5-0.7 ft.
PITT-10 CON-53	L-18-82	Vertical core on lower guard wall, downstream of lower gate monolith. Samples taken from 0.0-0.3 ft, 3.2-3.8 ft, and 6.2-7.0 ft.
PITT-10 CON-57	Gi-1-82	Horizontal core on lower guide wall, 19 ft down. Sample taken from 0.7-0.8 ft.
PITT-10 CON-58	Gi-2-82	Horizontal core below upstream gate gear on upper guide wall. Sample taken from 0.0-0.9 ft.
PITT-10 CON-59	Gi-3-82	Horizontal core on upper guide wall. Sample taken from 0.0-0.1 ft and 1.0-1.1 ft.
PITT-10 CON-61	Gi-5-82	Horizontal core, on lower guide wall, 20.5 ft down. Samples taken from 1.3-1.6 ft and 2.6-3.1 ft.
PITT-10 CON-54	Ga-1-82	Horizontal core on upper guard wall, 3.5 ft down. Samples taken from 0.0-0.1 ft and 1.1-2.2 ft.
PITT-10 CON-55	Ga-2-82	Horizontal core located 3.8 ft below upstream gate gear on upper guard wall. Sample taken from 1.3-1.9 ft.
PITT-10 CON-56	Ga-3-82	Horizontal core on lower guard wall, 19.5 ft down. Samples taken from 0.0-0.4 ft and 2.4-3.0 ft.

## Test Procedure

2. All of the material shipped, 213 ft of concrete and 92.3 ft of rock for a total of 13 vertical and 13 horizontal cores, from Lock and Dam No. 8 was examined and logged in the laboratory. Specimens for petrographic examination were taken from the upper, middle, and lower portions of 18 cores. Representative pieces of the cores that contained visual evidence of poorer quality concrete or significant reaction products, as well as pieces of typical concrete, were selected for more detailed examination.
3. Freshly broken surfaces, as well as pre-existing break surfaces, were examined megascopically and with a stereomicroscope.
4. Several pieces of core were sawed longitudinally or horizontally. One of each pair of sawed surfaces was ground smooth and examined with a stereomicroscope.
5. Cement paste concentrates from typical concrete samples were prepared and examined by X-ray diffraction (XRD). The paste was concentrated by gentle crushing of the concrete and sieving the material over a 45- $\mu$ m (No. 325) sieve. The material that passed this sieve was backpacked to minimize orientation and examined by X-ray diffraction. All X-ray patterns were made with an X-ray diffractometer using nickel-filtered copper radiation.
6. Samples of the white reaction products found in some voids and coating some break surfaces in the concrete were examined using a stereomicroscope and as immersion mounts using a polarizing microscope.

## Results

7. The majority of the concrete was nonair entrained. Only the more recent concrete overlays contained any entrained air.
8. The concrete was composed of 2-1/2-in. maximum size natural gravel and sand aggregates. The bulk of the gravel was composed of sandstone and chert with some miscellaneous aggregate particles, largely limestone and coal. This composition is common for gravels and sands from this region.
9. The general condition of the concrete from each core is described in the following paragraphs and illustrated in Figures 1 through 15.
10. Land wall (vertical borings). Cores L-1-82, L-5-82, and L-7-82 (Figures 1, 2, 3) are vertical cores taken from the land lock wall and the lower guide walls. The interior concrete was generally well consolidated, with only a few large entrapped air voids. Some evidence of poor consolidation was found in core L-5-82 at 1.0 ft. The concrete around a tie bolt was honeycombed.
11. Approximately 0.6 ft of new concrete overlaid the original concrete. The overlay was easily distinguished from the original concrete due to its medium gray (N4)<sup>(1)</sup> color and the fact that it was air entrained. This concrete overlay has remained intact and is in good condition. The bond

between the old and new concrete was good in core L-1-82 but was poor between the new concrete and the old concrete in cores L-5-82 and L-7-82. No segregation was observed in the original concrete of the three cores; the paste was a light olive gray (5 Y 6/1)<sup>(1)</sup> to a yellowish gray (5 Y 8/1)<sup>(1)</sup> and was hard and intact.

12. The concrete from cores L-5-82 and L-7-82 was deteriorated from below the overlay to a depth of approximately 2.5 ft. The cracks causing the deterioration were subparallel to the formed surface.

13. Alkali-silica gel was present as a coating on fracture surfaces and as a filling in voids. This reaction product was sound throughout the concrete in all three cores.

14. River wall (vertical borings). Cores L-10-82, L-12-82 and L-18-82 (Figures 1, 4, 5) were taken from the river lock wall and lower guard wall. The concrete in the three cores was similar and consisted of well consolidated, nonair entrained concrete. There was a 0.3-ft-thick overlay of new, air entrained concrete on the surface of core L-18-82. This overlay was composed of 1/4-in. maximum size natural gravel and sand aggregate with a composition similar to that of the other concretes in this set of three. Alkali-silica gel was present as a lining in most air voids. The concrete in core L-10-82 was intact except for some mechanical breaks, while cores L-12-82 and L-18-82 both had subparallel cracking to depths of 2.5 ft and 1.1 ft, respectively. Fracture surfaces in all three cores showed alkali-silica gel in voids with the amount of this reaction product decreasing with depth. At a depth of 19.7 ft in core L-10-82, there was an area of distinctly darker paste (medium light gray, N6)<sup>(1)</sup> occurring on one side of the core.

15. Land lock wall and guide walls (horizontal borings). Cores Gi-1-82, Gi-2-82, Gi-3-82, Gi-5-82, L-13-82, and L-14-82 (Figures 6, 7, 8, 10, 11) were taken from the land lock wall and upper and lower guide walls at different elevations. Each of the cores was similar in composition. All cores but Gi-5-82 exhibited some deterioration. None of the cores were air entrained.

16. The outer concrete surface of all of the cores with the exception of L-14-82, located just upstream of the lower gate recess, and Gi-5-82, located on the extreme lower guide wall, had been spalled off. Core L-14-82 had a 0.5-ft-thick overlay of dark gray concrete that remained intact. This overlay contained no coarse aggregate and was poorly consolidated around wire mesh located at the 0.24-ft depth.

17. Core Gi-5-82 did not contain any subparallel cracking. All other cores were cracked to some extent. Core Gi-2-82, located below the upper land wall gate gear, was completely deteriorated to rubble, with alkali-silica gel coating all fractured surfaces for its total depth. The remaining cores had subparallel cracks to a depth between 0.5 and 1.0 ft with alkali-silica gel on all broken surfaces and lining and filling voids.

18. Core Gi-5-82 intersected two construction joints. Below the joint at the 1.2- to 1.5-ft depth, there was alkali-silica gel present in voids in the concrete.

19. River lock wall and guard walls (horizontal borings). Cores Ga-1-82, Ga-2-82, Ga-3-82, L-9-82, L-15-82, and L-16-82 (Figures 12, 13, 14, 15) represented concrete at different elevations. Only the cores on the extreme upper and lower guard walls did not exhibit the subparallel cracking pattern common to much of the concrete examined.

20. All of these cores except Ga-1-82 and L-9-82 had some surface spalling. Core L-9-82 had a 0.5-ft-thick overlay of medium dark gray (N4)<sup>(1)</sup> air-entrained concrete that was poorly consolidated at the contact with the older concrete. The contact between the old and new concrete was loose.

21. Cores Ga-2-82, L-9-82, L-15-82, and L-16-82 all had subparallel cracking roughly parallel to the surface to depths between 0.6 ft to 1.0 ft. Core Ga-2-82 from below the upstream gate gear was completely broken to a depth of 1.0 ft and contained periodic pre-existing fractures for the rest of the core. All of the cores examined contained alkali-silica gel on broken surfaces and in voids for their total depth.

22. The XRD patterns of the cement paste concentrates revealed normal crystalline compounds for this age concrete. These included ettringite, hydrogarnet, calcium hydroxide, calcium silicate hydrate, tetracalcium aluminate carbonate-11-hydrate (monocarboaluminate), and possible aluminoferrite and gypsum. Contamination from the aggregate showed quartz, clay, possible amphibole, and feldspar and calcite. The calcite may be from the aggregate, from carbonation of the cement paste, or a combination of both. The other mineral constituents are expected as usual components of these aggregate rock types.

23. XRD patterns of two samples of white reaction material from broken surfaces indicated the presence of alkali-silica gel and ettringite. The gel had an index of refraction less than 1.498 and was the salt and pepper variety. This gel occurred as fillings of voids and coatings on broken surfaces indicating that alkali-silica reaction had occurred. Specific reactive aggregates were not identified.

#### Conclusions

24. All of the concrete examined showed frost damage to depths ranging from 1 to 2.5 ft for original concrete. This was seen as multiple cracks subparallel to concrete surfaces, as near surface fragmentation, and as lack of air entrainment. Since the original concrete predates the advent of air entrainment, it is normal to find such frost damage.

25. There was also abundant evidence of alkali-silica reaction in all concrete at all depths. This was seen as white alkali-silica gel coating old broken surfaces and filling or lining air voids.

26. While it was not feasible in the course of this examination to determine whether frost damage or the alkali-silica reaction occurred first, it is reasonable to say that both contributed to the deterioration of the concrete that is evident.

END

9-87

DTIC