

MICROCOPY RESOLUTION TEST CHART
NATIONAL BUREAU OF STANDARDS-1963-A

AD-A185 036

NAVAL POSTGRADUATE SCHOOL
Monterey, California

2

DTIC FILE COPY



THESIS

AN EFFECTIVE INFORMATION SYSTEMS
STRUCTURE
FOR THE KOREAN AIR FORCE LOGISTICS
ORGANIZATION:
A PRELIMINARY INVESTIGATION

by

Byung Kil, Park

June 1987

Thesis Advisor

Tarek K. Abdel-Hamid

Approved for public release; distribution is unlimited.

OCT 02 1987

87 9 25 146

UNCLASSIFIED

SECURITY CLASSIFICATION OF THIS PAGE

REPORT DOCUMENTATION PAGE

1a REPORT SECURITY CLASSIFICATION UNCLASSIFIED			1b RESTRICTIVE MARKINGS			
2a SECURITY CLASSIFICATION AUTHORITY			3 DISTRIBUTION/AVAILABILITY OF REPORT Approved for public release; distribution is unlimited.			
2b DECLASSIFICATION/DOWNGRADING SCHEDULE						
4 PERFORMING ORGANIZATION REPORT NUMBER(S)			5 MONITORING ORGANIZATION REPORT NUMBER(S)			
6a NAME OF PERFORMING ORGANIZATION Naval Postgraduate School		6b OFFICE SYMBOL (if applicable) Code 54Ah	7a NAME OF MONITORING ORGANIZATION Naval Postgraduate School			
6c ADDRESS (City, State, and ZIP Code) Monterey, California 93943-5000			7b ADDRESS (City, State, and ZIP Code) Monterey, California 93943-5000			
8a NAME OF FUNDING, SPONSORING ORGANIZATION		8b OFFICE SYMBOL (if applicable)	9 PROCUREMENT INSTRUMENT IDENTIFICATION NUMBER			
8c ADDRESS (City, State, and ZIP Code)			10 SOURCE OF FUNDING NUMBERS			
			PROGRAM ELEMENT NO	PROJECT NO	TASK NO	WORK UNIT ACCESSION NO
11 TITLE (include Security Classification) AN EFFECTIVE INFORMATION SYSTEMS STRUCTURE FOR THE KOREAN AIR FORCE LOGISTICS ORGANIZATION: A PRELIMINARY INVESTIGATION						
12 PERSONAL AUTHOR(S) Park, Byung Kil						
13a TYPE OF REPORT Master's Thesis		13b TIME COVERED FROM _____ TO _____		14 DATE OF REPORT (Year Month Day) 1987 June	15 PAGE COUNT 56	
16 SUPPLEMENTARY NOTATION						
17 COSAT CODES			18 SUBJECT TERMS (Continue on reverse if necessary and identify by block number) Korean Air Force Logistics MIS, Management Information System, Centralization Information System, Decentralization			
FIELD	GROUP	SUB GROUP				
19 ABSTRACT (Continue on reverse if necessary and identify by block number) Aviation logistics is a complex and multi-faceted activity, and is one in which management information systems (MIS) play a crucial role. This thesis examines the Korean Air Force Logistics MIS and proposes an alternative structure for the MIS function that should improve both efficiency and effectiveness. Specifically, we will focus on the centralization and decentralization of the MIS structure. The thesis reviews the current information system structure for the Korean Air Force Logistics organization, and indentifies some problem areas. An analysis of the advantages and disadvantages of centralization and decentralization is then provided based on literature findings. Following this analysis, a structured						
20 DISTRIBUTION AVAILABILITY OF ABSTRACT <input checked="" type="checkbox"/> UNCLASSIFIED UNLIMITED <input type="checkbox"/> SAME AS RPT <input type="checkbox"/> DTIC USERS			21 ABSTRACT SECURITY CLASSIFICATION Unclassified			
22a NAME OF RESPONSIBLE INDIVIDUAL Professor Tarek Abdel-Hamid			22b TELEPHONE (include Area Code) 408-646-2686	22c OFFICE SYMBOL CODE 54Ah		

DD FORM 1473, 84 MAR

83 APR edition may be used until exhausted

All other editions are obsolete

SECURITY CLASSIFICATION OF THIS PAGE

UNCLASSIFIED

19. ABSTRACT (CONTINUED)

methodology is employed to investigate the appropriate centralization and decentralization structure for the Korean Air Force Logistics organization. The benefits of the proposed structure are discussed. Finally, suggestions for future research in this area are provided.

Approved for public release; distribution is unlimited.

An Effective Information Systems Structure
for the Korean Air Force Logistics Organization:
a Preliminary Investigation

by

Byung Kil, Park
Major, Korean Air Force
B.S., Korean Air Force Academy, 1978



Submitted in partial fulfillment of the
requirements for the degree of

MASTER OF SCIENCE IN MANAGEMENT

from the

NAVAL POSTGRADUATE SCHOOL
June 1987

Accession For	
NTIS	<input checked="" type="checkbox"/>
DDIC	<input type="checkbox"/>
DAIC	<input type="checkbox"/>
DAIC	<input type="checkbox"/>
By	
Distribution/	
Availability Codes	
Dist	Avail and/or Special
A1	

Author:

Byung Kil, Park
Byung Kil, Park

Approved by:

Tarek K. Abdel-Hamid
Tarek K. Abdel-Hamid, Thesis Advisor

R. A. McGonigal
R. A. McGonigal, Second Reader

Willis R. Greer, Jr.
Willis R. Greer, Jr., Chairman
Department of Administrative Sciences

Kneale T. Marshall
Kneale T. Marshall
Dean of Information and Policy Sciences

ABSTRACT

Aviation logistics is a complex and multi-faceted activity, and is one in which management information systems (MIS) play a crucial role. This thesis examines the Korean Air Force Logistics MIS and proposes an alternative structure for the MIS function that should improve both efficiency and effectiveness. Specifically, we will focus on the centralization and decentralization of the MIS structure.

The thesis reviews the current information system structure for the Korean Air Force Logistics organization, and identifies some problem areas. An analysis of the advantages and disadvantages of centralization and decentralization is then provided based on literature findings. Following this analysis, a structured methodology is employed to investigate the appropriate centralization and decentralization structure for the Korean Air Force Logistics organization. The benefits of the proposed structure are discussed. Finally, suggestions for future research in this area are provided.



TABLE OF CONTENTS

I.	INTRODUCTION	10
	A. INTRODUCTION	10
	B. OBJECTIVE OF THESIS	11
	C. OUTLINE	11
II.	CENTRALIZATION AND DECENTRALIZATION ISSUES IN INFORMATION SYSTEMS: A LITERATURE SURVEY	12
	A. INTRODUCTION	12
	B. WHAT IS A CENTRALIZED INFORMATION SYSTEM	12
	C. WHAT IS A DECENTRALIZED INFORMATION SYSTEM	14
	D. WHAT IS A DISTRIBUTED INFORMATION SYSTEM	15
	E. ADVANTAGES AND DISADVANTAGES OF CENTRALIZATION AND DECENTRALIZATION IN THE LITERATURE	16
	1. Centralization	16
	2. Decentralization	18
	F. SUMMARY	20
III.	THE KOREAN AIR FORCE LOGISTICS MANAGEMENT INFORMATION SYSTEM	21
	A. THE AIR FORCE LOGISTICS SYSTEM	21
	1. Mission, Functions, and Organization	21
	2. Air Force Logistics Command Organization	23
	B. THE ELECTRONIC DATA PROCESSING CENTER	24
	1. Mission	24
	2. Organization	26
	3. Management Philosophy	27
	4. Application Development	28
	C. CURRENT MIS PROBLEMS	28

IV.	OVERVIEW OF CENTRALIZED AND DECENTRALIZED INFORMATION SYSTEMS IN THE LOGISTICS AREA	32
A.	INTRODUCTION	32
B.	EXAMPLES OF CENTRALIZED LOGISTICS SYSTEMS	32
1.	F-16 Technical Order Distribution Control at the 56th Tactical Fighter Wing	32
2.	Centralized Data Management at the U.S. Air Force Logistics Command	34
C.	AN EXAMPLE OF A DECENTRALIZED SYSTEM	35
D.	EXAMPLES OF DISTRIBUTED SYSTEMS	36
E.	SUMMARY	37
V.	RECOMMENDED MIS STRUCTURE FOR THE KOREAN AIR FORCE LOGISTICS ORGANIZATION	38
A.	INTRODUCTION	38
B.	A FRAMEWORK FOR THE CENTRALIZATION/DECENTRALIZATION DECISION	38
C.	RECOMMENDED STRUCTURE FOR THE KOREAN AIR FORCE LOGISTICS ORGANIZATION	43
1.	System Development	45
2.	Operations	46
3.	Management Control	48
D.	CONCLUSION	49
1.	Benefits of Centralizing System Development	50
2.	Benefits of Decentralizing Operations	50
3.	Benefits of Centralizing Management Control	50
VI.	SUMMARY AND DIRECTIONS FOR FUTURE RESEARCH	51
A.	THESIS SUMMARY	51
B.	SUGGESTIONS FOR FUTURE RESEARCH	52
	LIST OF REFERENCES	53
	INITIAL DISTRIBUTION LIST	55

LIST OF TABLES

1. HISTORY OF COMPUTERIZATION IN THE AFLC	25
2. FACTOR TABLE	44

LIST OF FIGURES

2.1	Centralized Information System ¹	13
2.2	Decentralized Information System	14
2.3	Loop Configuration ²	15
2.4	Star Configuration ³	16
3.1	The Organization of Air Force Logistics Command	23
3.2	Terminals Architecture	26
3.3	The Organization of EDPC	27
3.4	Software Development Procedure	29
4.1	Automated Wing Level TO Distribution Control System	33
5.1	The Degree of Centralization and Decentralization	39
5.2	Breakdown of the Information Systems Function	41
5.3	Basic Decision of Information Systems Function	42
5.4	Proposed MIS Structure for the Korean Air Force Logistics Organization	49

ACKNOWLEDGEMENTS

I would like to express my appreciation to many individuals in the Korean Air Force, who have assisted me in my studies at the Naval Postgraduate School. I am especially indebted to Dr. Tarek K. Abdel-Hamid, my thesis adviser, and Dr. R. A. McGonigal, the second reader, whose guidance and advice facilitated the successful accomplishment of this research. Finally, I am truly grateful as a Catholic to God, and thankful to my family, Miju, Hyunkyu, and YoungKyu, who gave me the encouragement needed during this period of study.

I. INTRODUCTION

A. INTRODUCTION

Information is a significant resource that is vital to an organization's operations and management. In modern organizations, the information resource is typically managed by the organization's computer-based management information system (MIS). While there are many definitions in the literature for what an MIS is, the one provided by Davis and Olson is the most comprehensive: "A management information system is an integrated, user-machine system for providing information to support operations, management, analysis and decision-making functions in an organization. The system utilizes computer hardware and software; manual procedures; models for analysis, planning, control and decision making; and a database." [Ref. 1: p. 6]

From the early 1970's, the Korean military organization has required an effective and efficient system of defense resource management. This requirement was finally answered in 1986, when the Korean military implemented the Defense Resource Management System based on Self Defense. This, in turn, has created the need for an MIS capability in order to operate the Defense Resource Management System effectively, for example, to provide timely and accurate information for the proper allocation of our defense resources.

Aviation logistics, our focus in this thesis, is a complex and multi-faceted activity which relies on computer technology to determine the allocations of aviation spare parts at the right time and at the right place. Aviation logistics is a vitally significant part of the Air Force readiness, and it is an area in which MIS plays a particularly critical role.

In order to establish an effective MIS, one needs suitable hardware and software, trained operators, programming standards, etc. In addition, one needs to structure the above resources in a manner that is most suitable to the organization's environment and its information requirements. A critical aspect of MIS structure is whether to centralize or decentralize. This decision is, however, a difficult one to make, for there are arguments in favor of both extremes and all the possibilities in between.

B. OBJECTIVE OF THESIS

This thesis will focus on the definition and selection of an effective MIS structure for the Korean Air Force Logistics organization. In particular, we will focus on the centralization and decentralization aspects of MIS structure.

The current MIS structure is centralized with respect to information systems functions and the application of computer-based management tools to the logistics system. Our objective is, therefore, to investigate whether the current centralized MIS structure is best suited to logistics support, or if a better structure can be developed. To investigate this issue, we will first research the literature for general guidance on centralization and decentralization. In addition, we will study existing MIS systems in the logistics area. Finally, a methodology will be selected to support a structured analysis of the advantages and disadvantages of centralization and decentralization for the particular environment of the Korean Air Force Logistics organization.

One limitation of this thesis which we would like to highlight at the outset is the fact that the analysis of the Korean Air Force Logistics system is based solely on the author's experience. There is a lack of published studies in this area. And because of time and distance limitations, it was infeasible to conduct any data gathering efforts.

C. OUTLINE

Chapter II provides an overview of the evolution of information systems, and introduces the advantages and disadvantages of centralization and decentralization. Chapter III reviews the mission of the Air Force Logistics Command, the current Korean Air Force Logistics MIS structure, and the overall organizational environment. Chapter IV illustrates actual computer system structures in the logistics area. Chapter V introduces a methodology to study the centralization decentralization decision, and uses it to select an effective MIS structure for the Korean Air Force Logistics organization. Chapter VI summarizes the conclusions of the this study and suggests areas for future research.

II. CENTRALIZATION AND DECENTRALIZATION ISSUES IN INFORMATION SYSTEMS: A LITERATURE SURVEY

A. INTRODUCTION

When computers came into major use during the early 1960s, they were perceived as powerful tools for improving organizational efficiency and reducing costs. For example, many organizations used data processing (DP) systems to reduce manpower costs in areas such as payroll, accounting, and finance. As a result of this focus, the data processing function was typically controlled by the accounting department. Moreover, in most cases computing was carried out by systems employing large centralized computers. [Ref. 2: p. 7] This made economic sense, since Grosch's Law indicated that the cost per machine instruction executed was inversely proportional to the square of the size of the machine. Economies of scale thus led many organizations to adopt a centralized architecture. [Ref. 3: p. 5]

As the demand for computerization grew, new user requests for computer applications began to overwhelm the centralized DP departments. As the backlog of user requests started rising, users' dissatisfaction with the DP service also increased. [Ref. 3: p. 18]

The 1970's brought the era of the relatively inexpensive minicomputers, and later the even less expensive microcomputers. This allowed management to manage DP facilities with less concern for hardware costs. Furthermore, the availability of both powerful software tools such as database management systems on the minis and micros as well as the development of fast and reliable computer networks are allowing many organizations to decentralize their DP operations. [Ref. 4: p. 144]

This chapter will provide an overview of the evolution of information systems and present a summary of literature findings on the advantages and disadvantages of centralization and decentralization.

B. WHAT IS A CENTRALIZED INFORMATION SYSTEM

Figure 2.1 depicts a centralized system architecture in which a number of terminals are supported by a single central computer. In addition to centralizing hardware intelligence, a centralized DP organization retains the decision making authority in managing the DP function at the top of the organizational pyramid. This

responsibility and authority includes determination of the most appropriate equipment and personnel, their selection and assignment, establishment of operating policies and procedures, and the evaluation of performance. [Ref. 5: p. 80]

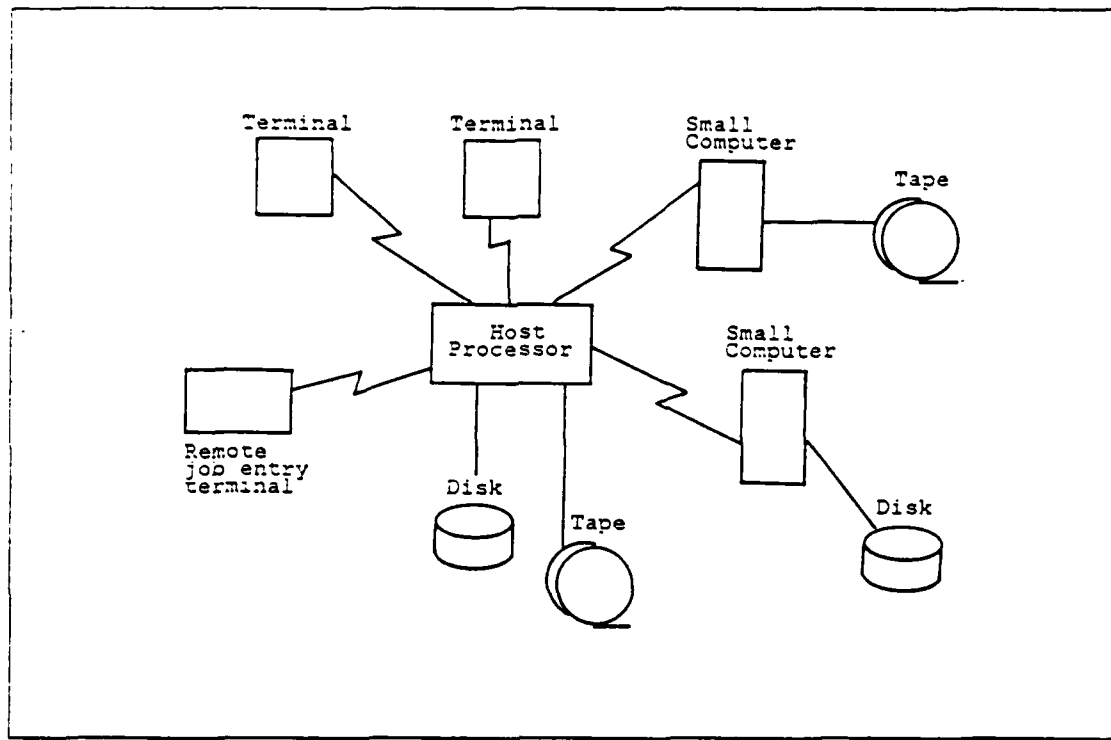

Figure 2.1 Centralized Information System¹.

Under such an organization, a centralized information system handles all processing at a single computer site, maintains a single central database, has centralized development of applications, has central provision of technical services, sets development priorities centrally, and allocates computer resources, such as hardware, software and personnel. [Ref. 6: p. 337]

The driving forces of centralization are the cost savings believed to be attainable in terms of computer power per dollar spent, the potential of fewer operating personnel, the opportunities to standardize routines, the increased use of single applications, and the high level of coordination, cooperation, and compatibility achieved in the development and maintenance of centralized data bases. The

¹Riley, M. J., *Management Information Systems, 2nd ed.*, p. 47, Holden-Day, Inc., San Francisco, 1981.

proponents of centralization in information systems, thus, focus on the efficiency that results from economies of scale. [Ref. 5: p. 79]

C. WHAT IS A DECENTRALIZED INFORMATION SYSTEM

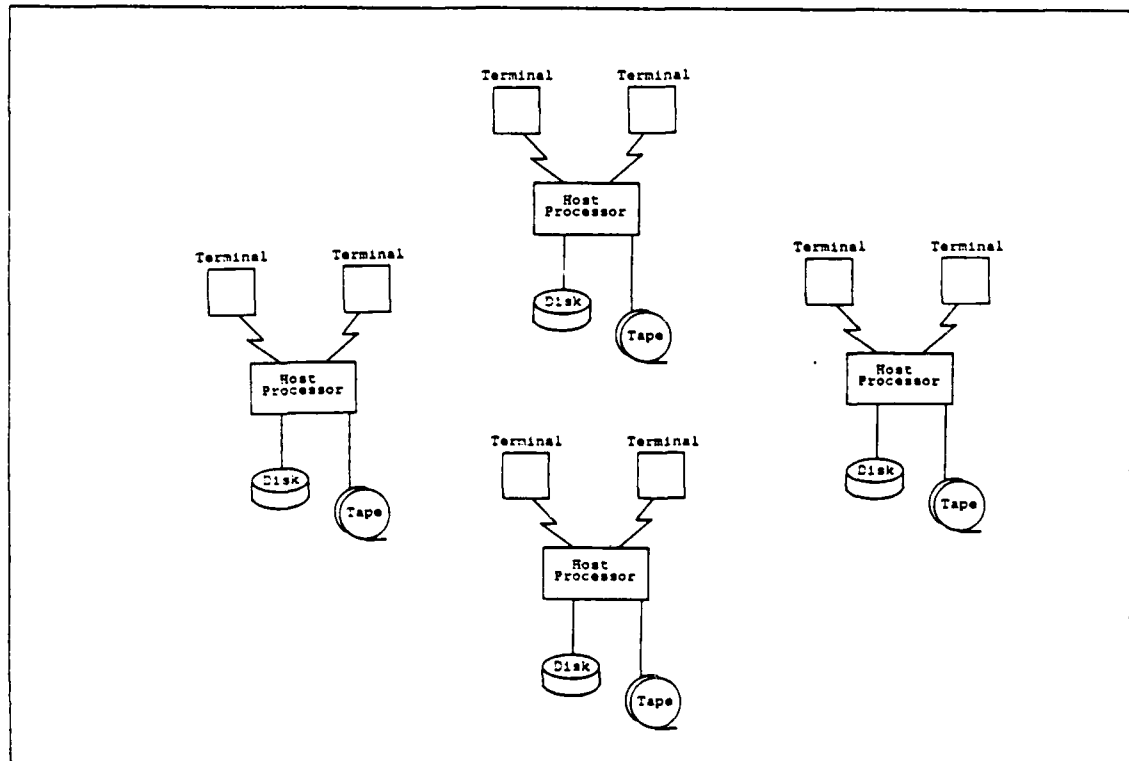

Figure 2.2 Decentralized Information System.

Figure 2.2 shows a decentralized architecture, in which separate and independent computer systems support and are operated by different organizational units. Decentralization is motivated by the desire to make data processing more responsive to the users of the system. In a decentralized organization, computing resources are allocated and managed by the users' organizations, and are therefore more sensitive to their needs. Local data processing staff can move quickly to satisfy changing requirements. This would be attractive in cases when computer personnel need to be particularly knowledgeable about certain areas of the user's operations. In such cases, it is advantageous to locate systems analysts and software developers in the users' organization. Furthermore, when user managers are directly responsible for DP development and processing costs, they typically pay more attention to the operational efficiency and cost effectiveness of computer applications. [Ref. 7: p. 15]

Decentralization, thus, is pushes decision making responsibility and authority down the hierarchy to subordinate and branch managers. A completely decentralized system is separated into autonomous sites, each one fully controlling its resources, without any interaction between the units and without any central control. Advocates of a decentralized system favor the effectiveness achieved by having autonomous units customized to local user needs. [Ref. 6: p. 338]

D. WHAT IS A DISTRIBUTED INFORMATION SYSTEM

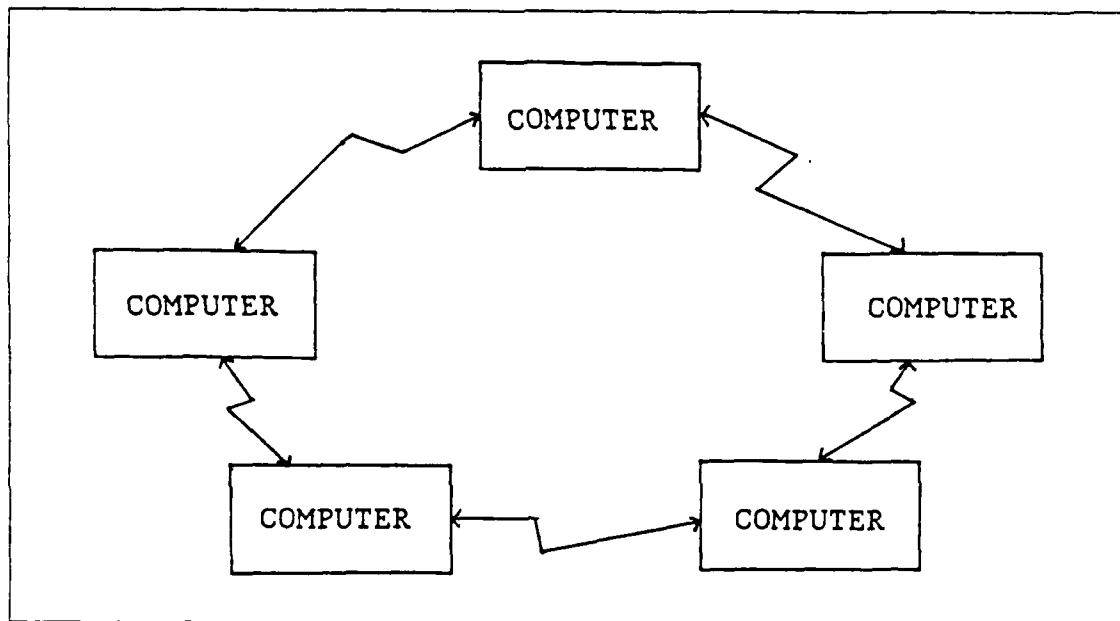

Figure 2.3 Loop Configuration².

Distributed computer systems distribute computer power (e.g. microcomputers, minicomputers, large-size computers) to end user sites, while maintaining interconnectivity through shared communication links. Figures 2.3 and 2.4 show two possible distribution configurations, a loop and a star respectively. Distributed processing has been facilitated by the availability of both mini and micro computers on the one-hand, and reliable communication networks on the other. Depending on how the distributed processing system is organized, varying degrees of centralized and decentralized organizational structure may be supported.

²Riley, M. J., *Management Information Systems, 2nd, ed.*, p. 110, Holden-Day, Inc., San Francisco, 1981.

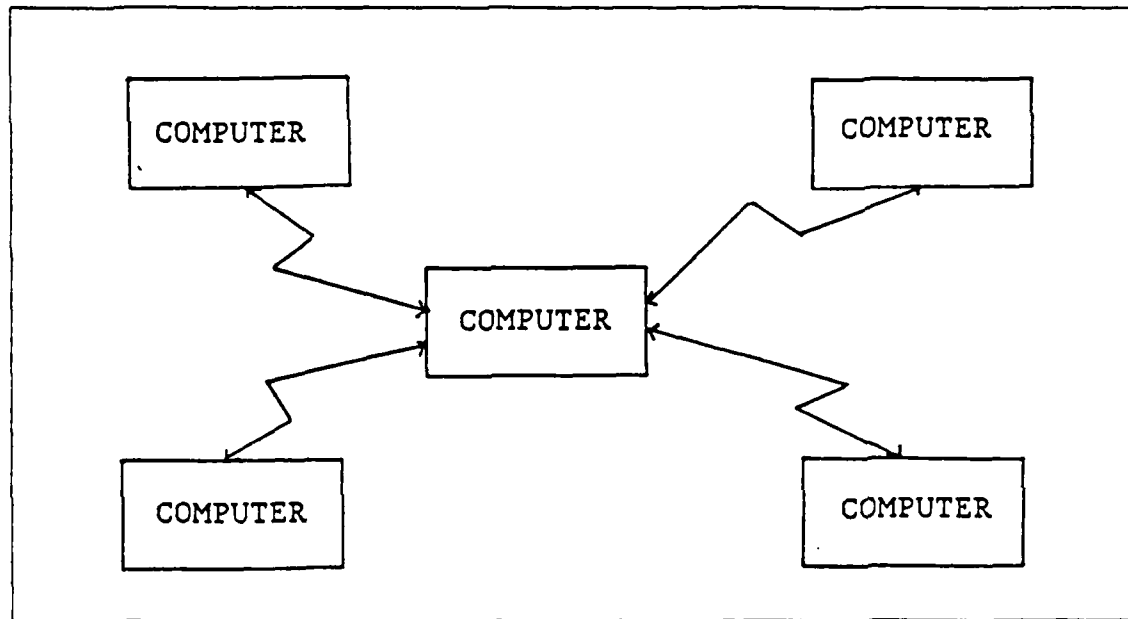

Figure 2.4 Star Configuration³.

Distributed systems seek to achieve the advantages of both centralization and decentralization by building a system that combines local autonomy with centralized controls. In such an environment some organization-wide applications would be centralized while others that are sub-unit specific would be decentralized. Distributed systems can thus facilitate local autonomy, initiative, and responsibility, without obliterating the advantages of centralized data processing planning and control. [Ref. 3: p. 202]

E. ADVANTAGES AND DISADVANTAGES OF CENTRALIZATION AND DECENTRALIZATION IN THE LITERATURE

1. Centralization

a. Advantages

(1) Economics of scale. Large hardware systems are more economical than collections of small systems. This is achieved by maintaining high utilization levels by consolidating workloads in a shared environment. Large centralization systems which permit the instantaneous and simultaneous updating of files on a direct access storage device can also reduce the need for record storing duplication, program preparations,

³Riley, M. J., *Management Information Systems, 2nd, ed.*, p. 110, Holden-Day, Inc., San Francisco, 1981.

and maintenance. Additionally, the data storage cost per bit is much lower with large storage units. [Refs. 1,3,8,9,10,11,12: pp. 638, 184, 112, 195, 2, 41, 93]

(2) Ease of management control. It is easier for top management to control individual operations when uniform information reporting and evaluation systems are used. In addition, it increases the ability to implement and follow master plans for DP that are consistent with long range plans of the organization as a whole. [Refs. 3,5,6,8,10,11,13: pp. 187, 103, 323, 112, 2, 41, 232]

(3) More sophistication of software systems. A large centralization operation can offer more powerful and more complex software tools e.g., languages, large database management system, etc. [Refs. 1,3,13: pp. 635, 188, 232]

(4) High quality professionals. A central group can afford highly trained data processing management and highly professional system analysts and programmers. It would provide such professionals with more rewarding career paths, more sophisticated equipment, and better training programs. [Refs. 1,3,5,6,8,9,10: pp. 635, 189, 103, 323, 112, 194, 1]

(5) Minimizing software development costs. A centralized organization permits the sharing of applications and systems, and thus minimizes the redundancy and duplication of programming work. [Refs. 1,3,5,6,8,9.: pp. 636, 185, 103, 323, 112, 195]

(6) A central installation allows for the development of an organization-wide database. These organization wide databases can enhance top management decision making activities. [Refs. 3,7,8: pp. 192, 15, 112]

(7) Standards. Centrally imposed standards for hardware, software, programming languages, and data design are crucial for successful project development. [Refs. 1,9,13,14: pp. 635, 195, 232, 57]

(8) Quality. A centralized professional group is more likely to write structured programs that are well documented. As a result, centrally planned systems are more likely to be designed for maintenance. [Refs. 3,12: pp. 189, 93]

(9) Negotiating position. Relationships with vendors can be leveraged if the vendors deal with a central agency which represents the economic power of the entire enterprise. Prices, delivery schedules, and quality of support from vendors can thus be improved for an enterprise which centralizes its purchasing function for DP. [Refs. 9,13: pp. 195, 232]

b. Disadvantages

(1) Responsiveness to user needs. The central group is typically too distant from the users to acquire a detailed knowledge of local problems. Also, job scheduling conflicts on a centralized system would mean that the computing facility is not always available to user departments when it is needed. [Refs. 3,6,11,12: pp. 190, 323, 42, 93]

(2) Higher communication costs. Centralized data with large storage units may result in major telecommunications costs in order to access them. This is increasing in significance since communication costs are not decreasing as fast as computing and storage costs. [Refs. 3,9,13: pp. 184, 194, 232]

(3) Higher risk. If a breach of security occurs on a centralized computer, the harm may be widespread. Also, downtime in centralized systems can be catastrophic. If the large machine goes down, the total system is completely degraded unless the information system has backup facilities. [Refs. 1,3,6,8,13: pp. 639, 187, 323, 112, 232]

(4) Poor response time. The software path lengths of large machines have become great. Because of this, The cost per transaction is relatively high, and throughput and response time can be poor. [Ref. 3: p. 188]

(5) High installation cost. Cost of installing a large centralized computer is high relative to that for minis. There are large setup costs in the form of building renovation, air conditioning, sophisticated security systems, etc. [Refs. 6,8: pp. 323, 112]

2. Decentralization

a. Advantages

(1) Rapid response to local processing needs. Local systems are better customized to their specific needs, and they usually get faster response times because of smaller workloads and no need for data transmission. [Refs. 3,5,6,7,10: pp. 186, 102, 323, 15, 2]

(2) Software is designed to meet the needs of a limited set of users, and as a result it is often simpler. Thus, application programs are easier to maintain and highly specialized system programmers are usually not needed. [Refs. 1,3,7: pp. 635, 189, 15]

(3) Familiarity with local problems. Local system developers are closer to the end user problems, and are thus in a better position to develop systems that meet user needs. Local computing needs can be locally justified and prioritized. [Refs. 1,3,5,10: pp. 641, 190, 102, 2]

(4) If a breach of security occurs on a peripheral computer, the harm is restricted to a local area. [Refs. 1,3: pp. 639, 187]

(5) Because users work closely with their resident systems people, they are typically more computer literate. [Ref. 3: p. 199]

(6) Profit and loss responsibility. When computer equipment is decentralized to user departments, costs are also decentralized to users. This tends to make the user departments more sensitive to cost and benefit considerations. [Refs. 1,5,10: pp. 635, 102, 2]

(7) Highly reliable. Local systems are unaffected by telecommunications failures and large machine software crashes. Minicomputers, being simple, are generally highly reliable. [Refs. 3,6: pp. 186, 323]

(8) Lower transmission costs. Decentralization can lower transmission costs because of local processing, fewer messages transmitted, local dialogue processing, and local data storage. [Ref. 3: p. 184]

(9) Accuracy and timeliness for data entry. Users are responsible for their own on-line data entry, and are responsible for its accuracy and timeliness. This tends to minimize errors committed. [Ref. 3: p. 187]

(10) Lower installation cost. Most minicomputers do not need air conditioning, false floors, or special building facilities, and do not need highly trained operators and staff to run the installation. [Ref. 3: p. 185]

(11) Shorter software path length. Minicomputers have a much shorter software path length, hence more of the raw computer power is used for application programs. [Ref. 3: p. 185]

(12) Effective dialogue. Processing power close to the user permits economical use of psychologically effective dialogue. [Ref. 3: p. 186]

b. Disadvantages

(1) Multiple decentralized systems can result in duplication of programming effort and to data redundancy. [Refs. 3,6: pp. 185, 323]

(2) Decentralized, nonstandardized data make it extremely difficult to incorporate the data in a later organization-wide management information system. [Refs. 1,3,6: pp. 641, 187, 323]

(3) Complex and expensive migration for an integrated system. Migration from incompatible decentralized systems to an integrated system or distributed network is so complex and expensive that in practice it is rarely achieved. [Refs. 3,6: pp. 188, 323]

(4) The role of director of MIS in a decentralized organization is more complex than in a centralized one. [Ref. 15: p. 42]

(5) Invariably, the cost for a decentralized operation is greater overall than a centralized operation. [Ref. 15: p. 42]

(6) A decentralized organization could lack the critical mass to attract high-quality DP professionals. [Ref. 15: p. 42]

(7) A decentralized organization could lack the benefits and leverage of company-wide purchasing arrangements with vendors. [Ref. 16: p. 5]

(8) Equipment selected by different user groups can be incompatible. [Ref. 3: p. 74]

F. SUMMARY

In the above overview of the literature on centralized and decentralized systems, arguments both for and against centralization and decentralization of information system structure were discussed. Centralization of the computer facility has historically been favored by organizations in order to reduce costs. On the other hand, decentralization is perhaps more appealing to organizations with a heterogenous user group. But this is an oversimplification. Organizations pondering the centralization or decentralization decision need to follow a structured approach that weighs the many advantages and disadvantages discussed above within the context of their own organizational characteristics and goals. Such a methodology is proposed in Chapter V.

III. THE KOREAN AIR FORCE LOGISTICS MANAGEMENT INFORMATION SYSTEM

A. THE AIR FORCE LOGISTICS SYSTEM

1. Mission, Functions, and Organization

The objective of the Korean Air Force Logistics system is to maintain air force readiness and to support tactical aviation through efficient utilization of logistics resources. Generally, logistics is comprised of the capabilities and processes that translate weapon systems into an effective military capability by assuring the availability of various integrated elements such as support equipment, spare repair parts, transportation, etc.

The Air Force Logistics organization consists of three parts: personnel management, financial management, and material supply management. Personnel management encompasses managing maintenance technicians, suppliers, etc. in order to ensure maximum air force readiness. Financial management involves managing the required funds for operation of the Air Force weapon system. Material supply management is responsible for controlling materials to provide support for tactical aviation units. This thesis will focus on the material supply management aspect of the logistics system, which because of its high complexity is highly dependent on computer systems.

The Air Force logistics system's material supply management subsystem includes the following five logistics functions: requirements, procurement and acquisition, distribution, maintenance, and disposal. Requirements involve identifying required materials and quantities of items needed for accomplishing organization tasks during a specific period. Procurement and Acquisition uses these established requirements to obtain materials and equipment for utilization in support of organization functions. The distribution function entails the delivery of materials to user organizations. The objective of maintenance is to support the tasks of maintaining equipment through operation of technical supporting units. Disposal, the fifth activity of the materials logistics function, is concerned with the disposal of salvage materials and equipment.

From the above we see that the life cycle of materials supply management in the Korean Air Force logistics supply system begins with providing services during the

requirement period and continues until final disposal of materials due to their obsolescence.

The Korean Air Force Logistics supply system maintains three levels of inventory and maintenance. The three levels of inventory are wholesale, retail-intermediate, and retail-consumer. The wholesale inventory level is responsible for requirements determination, material distribution and fulfillment of customer demands at the national level. The items managed by the wholesale inventory level are classified as consumable, intermediate level repairables, depot level repairables, modification kits and end items. The computer system is utilized here to store historical data as well as demand forecasting data on supply system performance, etc. and make this information accessible to management.

The retail-intermediate inventory level has a major role in requirements determination for the tactical units. Its function is to link the consumer and wholesale levels for support of defined geographic areas, including area resupply and consumer level maintenance. The items demanded at the retail-intermediate level are requested from the wholesale level through an on-line EDP facility. The supply system's objective in weapon system readiness is to minimize the requisition response times. The most efficient way to do this is through the retail-intermediate level of inventory.

The retail-consumer inventory level is limited in range and depth. It consists of inventory held by the final customer unit in an established supply distribution system for the unit's own use or consumption. This level does not use EDP facilities.

The three levels of maintenance operated by the Air Force Logistics system are the depot, intermediate, and organizational. The Air Force logisticians may use overseas and domestic civil support services for any of the required levels. The depot maintenance level includes rebuilding of parts, and complete overhaul and calibration of equipment, as well as the performance of complex maintenance.

Intermediate maintenance includes corrective and preventive maintenance activities in support of operating units. The types of maintenance activities include detailed inspection of equipment and components, limited calibration, and the repair of end items by the removal and replacement of major modules, assemblies or parts.

Organizational maintenance is normally performed at the operational site. Its action is limited to periodic checks of equipment performance, visual inspections, and the removal and replacement of defective parts and components.

The Air Force Logistics supply system's customers operate under a decentralized requisition concept in which the customers submit their requisition for material to their local level of operations rather than directly to the wholesale level.

2. Air Force Logistics Command Organization

The Korean Air Force Logistics Command (AFLC) is responsible for managing the allocation of logistics resources to support maximum weapon system operational availability. It functions as an intermediate echelon command among the tactical units of the Korean Air Force under the policies and planning of Headquarters. This command has six major divisions to perform its mission. Figure 3.1 shows the organization of the Korean Air Force Logistics Command. The following paragraphs will explain the basic missions and responsibilities of the six divisions.

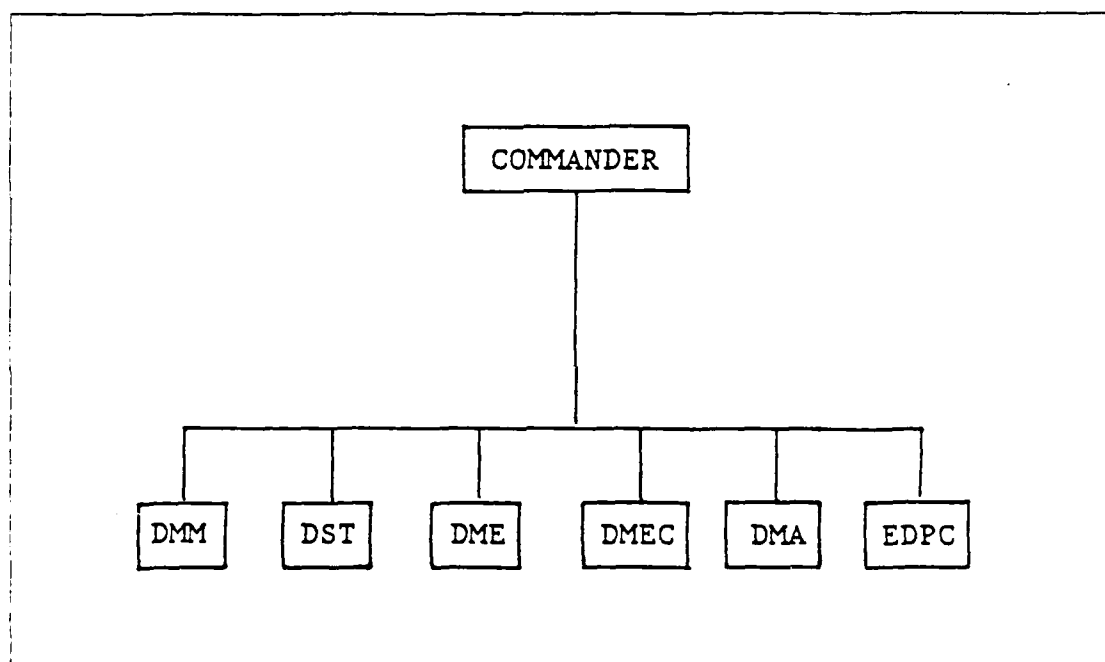

Figure 3.1 The Organization of Air Force Logistics Command.

The major role of the Directorate of Materials Management (DMM) is to establish the aviation logistics budget according to determined requirements, and to procure all materials needed to supply the tactical and supporting units within the Korean Air Force. To manage effectively, DMM relies heavily on Electronic Data Processing Center's computer services to access historical transaction data, demand forecasting data, current assets data, etc.

The Depot of Storage and Transportation (DST) has been given responsibility to ensure the protection of materials from theft, damage, and obsolescence. They also control the physical inventory of the items needed by the ultimate users. This depot also deals with the disposal of salvage, scrap, excess and obsolete materials. DST stores all material for the Korean Air Force, and also has a role in transporting these materials to arrive at the customer when and where required. The actual administrative control of materials management is done by DMM.

The primary task of Depot Maintenance and Equipment (DME) is the overhaul of aircraft on a scheduled basis. It performs the maintenance of aviation end items which are beyond the capabilities of the intermediate and organizational maintenance level facilities. These items are usually the major components of aircraft systems such as the engine, gearbox, and the direct ground support equipment for the operation of the aircraft. EDPC stores historical data on direct consumption of spare parts for repair of end items. This allows for accurate estimation of aircraft maintenance costs.

Depot Maintenance and Electronics and Communications (DMEC) performs the maintenance of radar equipment, ground communications equipment, and weather equipment.

Depot of Maintenance and Ammunition (DMA) performs the major maintenance of equipment related to the armament of the aircraft.

Electronic Data Processing Center (EDPC) provides logistics software development and support, establishes job processing standardization, collects data, and provides analysis and guidance for each of the other major divisions. EDPC is discussed in more detail in the next section.

B. THE ELECTRONIC DATA PROCESSING CENTER

1. Mission

The major objective of EDPC is to efficiently support tactical aviation by applying computer-based management tools to the logistics system. To accomplish this, EDPC provides a database for logistics management, develops and supports software systems to support the decision making and analysis activities of management, and controls and maintains existing software. The EDPC assists each division to perform their specialized logistics mission at AFLC.

Since the Korean War, the U.S. government has provided technical assistance in the information system area to the Korean military services. In 1967, the Punch Card Accounting Machine (PCAM) was installed at the Korean Air Force Logistics Command. The purpose of PCAM was to control funds for spare parts requisition to Continental United States, and to help manage inventories by the Military Advisory Group. With the end of the Grant-Aid in 1973, the AFLC switched from the PCAM to an IBM 370 135 system. This move became the turning point for computerizing and partially standardizing the logistics system procedures. In 1976, with an additional change from the IBM 370 135 to a UNIVAC 90 30, the Air Force Logistics entered the evolutionary stage of developing computerized depot level maintenance.

TABLE I
HISTORY OF COMPUTERIZATION IN THE AFLC

Periods	Computer	Major applications
1967	PCAM	Depot supply -posting control -inventory
1973	IBM 370 135	Depot supply -property accounting -requirement computation -stock number user directory (SNUD) -depot asset analysis
1976	UNIVAC 90 30	Depot supply maintenance -logistics on-line supporting -base asset management -fund control -logistics management analysis
1985	PRIME 9950	Army Logistics Command on-line

Table I shows the computerization history of the Korean Air Force Logistics Command [Ref. 17].

In 1985, a PRIME 9950 computer was installed with 16 terminals. The 16 terminals were assigned as 4 to DMM, 1 to Directory of Maintenance Management, and 11 to EDPC as shown in Figure 3.2 [Ref. 17]. DMM uses its terminals only for

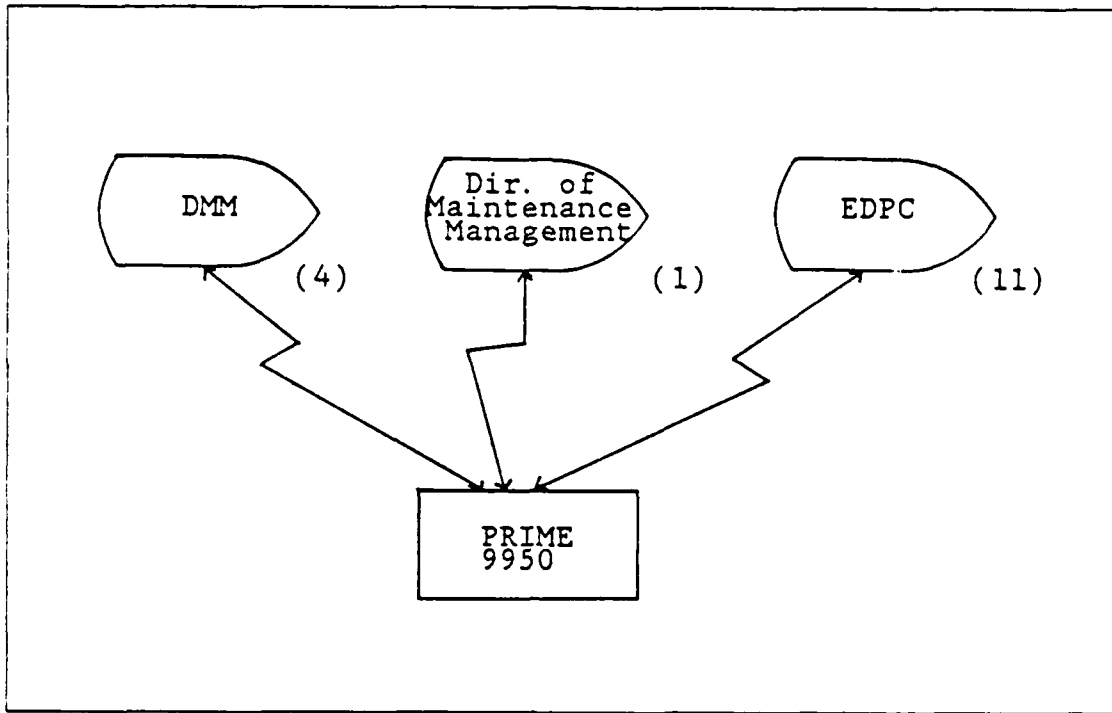

Figure 3.2 Terminals Architecture.

inquiries concerning materials back orders, issues, receipts and inventory balances. The Directory of Maintenance Management uses its terminal for inquiries concerning depot maintenance scheduling status for repair items. The EDPC uses its terminals for data entry and software development.

2. Organization

The EDPC is comprised of four sections to perform its mission. It is divided into the supply system design/analysis, maintenance design/analysis, programming, and operations sections. Figure 3.3 shows the organization of EDPC [Ref. 17].

The supply system design/analysis section develops new systems, and revises existing systems relating to supply functions as required by users. Relevant maintenance of existing systems is accomplished by the maintenance system design and analysis section. The programming section provides the software development function after system design is completed. The operations section controls and manages computer utilization and schedules daily, weekly, and monthly.

The EDPC staff consists of system designer/analysts, programmers, and operators, both civilians and officers. A new employee is initially trained for a couple

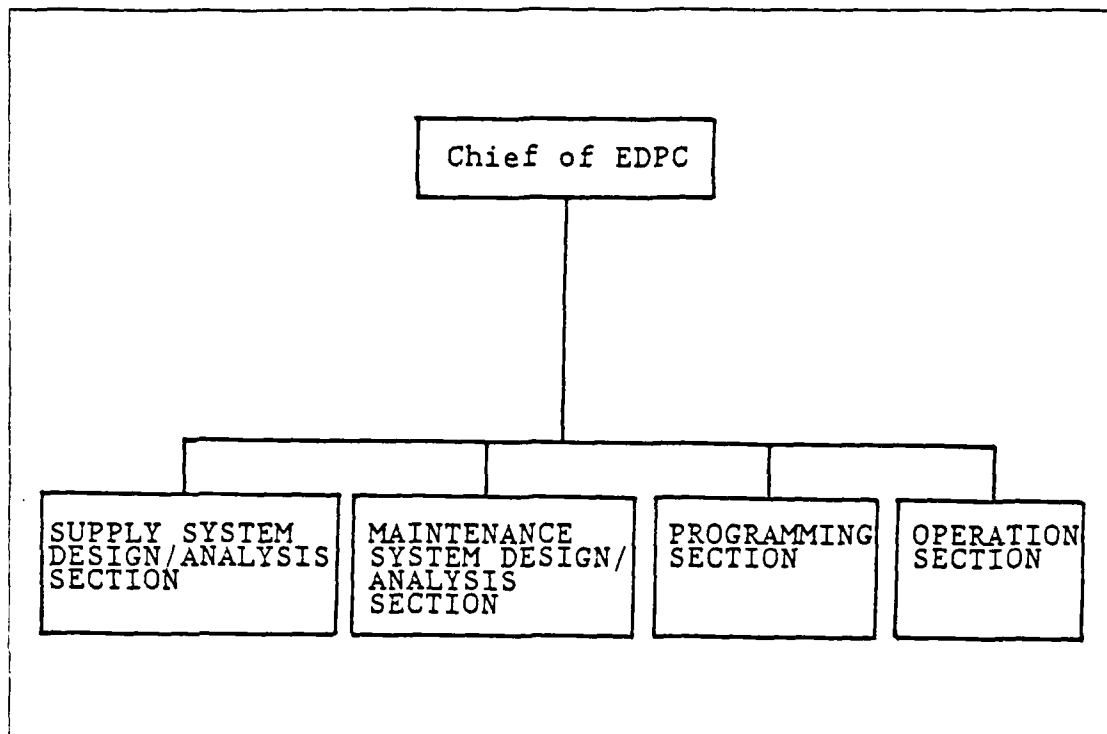

Figure 3.3 The Organization of EDPC.

of months by an employee familiar with the system. After the initial training, there is no formal scheduled training for the members of EDPC.

3. Management Philosophy

The management of EDPC is centralized with respect to system development, operations, and management control.

When the EDPC selects new equipment approximately every 5 years, the EDPC surveys various equipment from domestic computer vendors and collects data on alternative equipments. The EDPC then provides alternative equipment recommendations to HQ. The actual selection of the equipment is done at HQ.

All of the operations procedures relevant to operating the main computer and assigned terminals are imposed by EDPC. When employees operate the computer or users take data accessed through assigned terminals, they follow those procedures.

EDPC assigns job priorities centrally under routine job scheduling functions, such as on a daily or monthly basis. However, the user can input according to his particular needs with respect to a required completion date. Too often unscheduled jobs which are requested by users, such as for new software development or modifying the existing system, are given priorities determined by the users themselves.

The EDPC uses high-level languages, such as COBOL and FORTRAN. The documentation of each system is established to ensure maintainability of systems and programs by an assigned system designer analyst.

4. Application Development

Figure 3.4 [Ref. 17] shows software development procedures at EDPC. When EDPC gets a user requirement to develop new or change existing software, the system designers analysts of EDPC study its feasibility. Next, they analyze what system the user needs, and start preliminary system design. Following reviews of test results, EDPC finally supports user requirements after several iterations of systems analysis has been performed.

C. CURRENT MIS PROBLEMS

The preceding discussion has provided a brief overview of the Air Force Logistics structure as well as the role and responsibility of the AFLC. The discussion showed the different functions performed by each division. We also showed how the logistics MIS function is centralized with respect to system development, operations, and management control. This section will discuss some of the problems with the current MIS structure based on the author's experience at EDPC. Current MIS problems are presented below.

First, there is no up-to-date database management system to manage the large logistics database. This results in an inefficient system. Tremendous time is spent on updating existing files. Approximately 4 hours are spent on daily updates, and monthly jobs take about 60 hours. Highly trained personnel are required due to the fact that the updating process is very complicated. If they are not available, the system may collapse.

Secondly, the five other divisions are all supported by the centralized EDPC. Annually, the five other divisions will submit approximately 1,500 requests for development and 250 modification requests. Because of EDPC's limited capability, it is not able to satisfy the five divisions' requests when they are needed. Thus, the response to user needs is not prompt.

Third, communication between divisional senior officers, end-users, and the system designer analysts at EDPC is often distorted and vague because of incompatibilities in the personnels' perceptions and training. This results in a general lack of conformance of systems to user needs. Thus, In many instances, the final

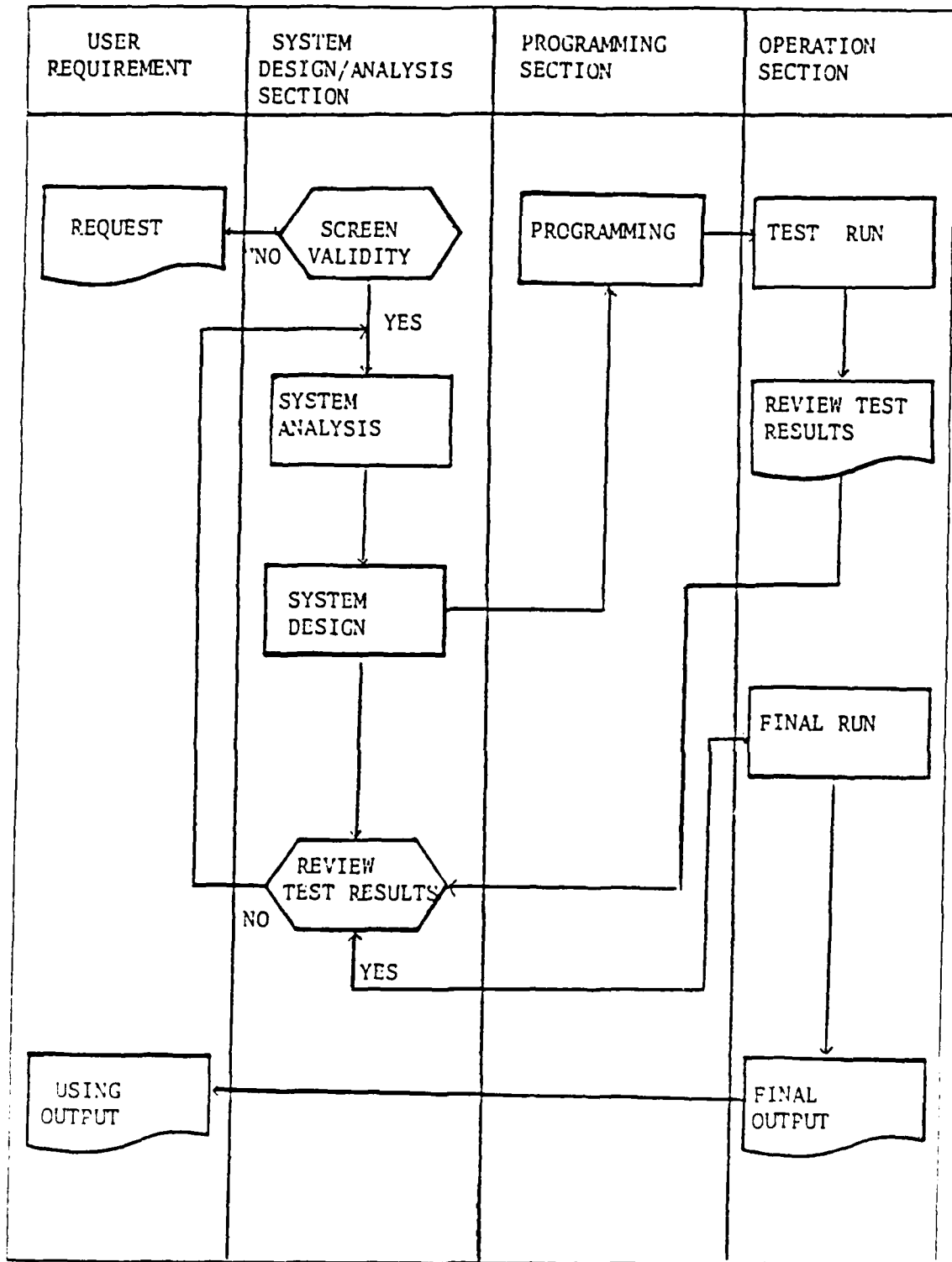

Figure 3.4 Software Development Procedure.

system will not be acceptable to the user due to the fact that the system designer analyst did not fully comprehend what the user wanted. The problem is further exacerbated by the fact that there is no user-involvement in the system review and test processes. The only instances of user-involvement is at the beginning and the end of the process.

Fourth, users fail to adequately identify their information requirements. This is due partially to the fact that the users are not familiar with automated systems and their capabilities and limitations. Users need to become better educated.

Fifth, each of the five logistics functional areas have their own systems. These systems are not adequately integrated. As a result, the existing architecture can't fully support the high-level decision-making functions of the divisional senior officers in logistics.

Sixth, in order to keep a current record, a material transaction is centrally fed into the main computer at the EDPC. This task is accomplished every day. In addition to this routine task, EDPC accomplishes large volume jobs such as annual material inspections surveys in which all materials in inventory are accounted for. Annually an average of 340,000 pieces of data are fed into the computer. Due to the sheer volume of this input, there is a great possibility of error, and a huge amount of time is spent making the actual data entry.

Seventh, during large volume jobs, like the annual material inspection survey, overall system performance may be low due to the fact that short-duration jobs are pushed back. There is only one computer, and the system can not completely handle the volume.

Eighth, when the computer goes down at EDPC, it creates a backlog which affects the other 5 divisions. All printing is accomplished centrally at EDPC, and when the hardware is down, the five division's tasks are also delayed.

Ninth, at EDPC, a new employee is initially trained for a couple of months by an employee familiar with the system. After the initial training, there is no further scheduled training for EDPC personnel. New concepts and ideas about the evolving technology are not typically distributed to the employees, who as a result fall behind in their knowledge. Thus, EDPC can not provide really advanced logistics management tools.

Lastly, EDPC does not always have control over prioritizing its jobs. The five other division chiefs are senior to the EDPC officer. As a result, a simple job which

could only take a day, may wait indefinitely, because it has been preempted by a higher priority job for a senior division chief.

The above represent serious deficiencies in the MIS service provided by EDPC. The major failure of the current Korean Air Force Logistics MIS is its unresponsiveness. It does not adapt to the needs of its users as new requirements and procedures become apparent. The remainder of this thesis will address what changes could make the MIS more effective.

IV. OVERVIEW OF CENTRALIZED AND DECENTRALIZED INFORMATION SYSTEMS IN THE LOGISTICS AREA

A. INTRODUCTION

In the industrial or commercial sector, logistics has traditionally been defined to include such activities as material flow, product distribution, transportation, warehousing, etc. In the military domain, logistics is concerned with the various aspects of maintenance, system and product support of military equipment e.g. aircraft parts.

Recently, the critical role that logistics plays in military operations has been growing at a fast rate, stimulated primarily by technological, sociological, and economic trends. For example, systems and products have become more complex as technology advances. In view of these trends, there is a growing need for more effective and efficient management of logistics resources.

Computerization has had a significant impact on the logistics area. Computer technology offers the logistician an enormous capability to store, program, format, and manipulate data and words. As a result, logistics information systems have increased in usage and variety. This chapter will illustrate example computer applications in logistics in both the military and commercial sectors.

B. EXAMPLES OF CENTRALIZED LOGISTICS SYSTEMS

1. F-16 Technical Order Distribution Control at the 56th Tactical Fighter Wing

The F-16 technical order (TO) control system is a centralized automated system to control and distribute TO's at the 56th Tactical Fighter Wing (56TFW) at MacDill Air Force Base. [Ref. 18: pp. 32-35] The complexity of this new operational weapon system made the use of computer-based control functions a necessity.

The U.S. Air Force has two types of TO control systems. One is the Technical Order System, and the other is the Technical Order Distribution System. The Technical Order Distribution System places three levels of activity under the Base Technical Order Distribution Office (BTODO) in a wing. These levels are: the Technical Order Distribution Office (TODO) which is generally placed at wing level, the Technical Order Distribution Accounts (TODA), which normally is at the squadron level, and the Technical Order Distribution Subaccounts (TODS) at a subordinate level

within a squadron. The 56TFW TODO is supported by twelve TODA's, including the following three major TODA's: the aircraft generation squadron (AGS), the equipment maintenance squadron (EMS), and the component repair squadron (CRS). This TODA echelon in turn, controls a total of twenty TODS.

Since the F-16 TO's were part of a new weapons system, there were frequent TO changes. The 56TFW spent a lot of time replacing and controlling the TO changes. Survey results indicated that about 205 man-hours were expended each week in maintaining TODA and TODS distribution control records. It was also determined that all TO records maintained at the TODA and TODS are duplicates of those maintained by the TODO.

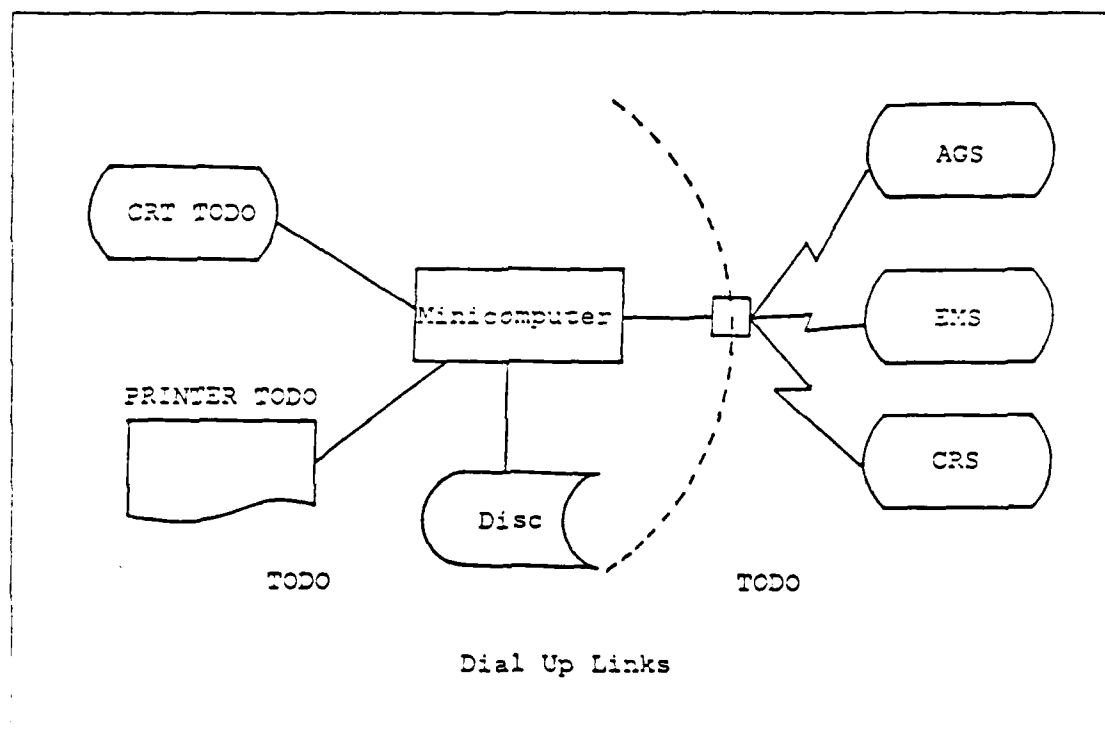

Figure 4.1 Automated Wing Level TO Distribution Control System.

The knowledge gained in analyzing the existing TO distribution at the 56TFW provided the basis for eliminating the duplicate record keeping function, thus releasing maintenance personnel at the TODA and TODS from the preparation and maintenance of duplicate records. This was accomplished by using the local minicomputer on a given Air Force base. Figure 4.1 shows the basic concept of the

TO distribution control system at the wing level. It is composed of: (1) A local minicomputer to handle data storage and retrieval; (2) Magnetic disc storage for programs, data formats, and TO control record data; (3) A terminal at the TODO for inputting the Technical Order Numerical Index and Requirement Table (which matches the current TO inventory), and for updating the TO on the location, quantity on hand or on order of parts inventory (this terminal supports centralized control and integration of all TODO and TODA sites); (4) A printer at the TODO to print inventory data and Numerical Index and Requirement Table Listings which can be used to check inventory accounts and to determine demand; and (5) A terminal at each TODA that interfaces with the computer through a dial-up link. These terminals are used by TODA and TODS personnel to identify TO accounts, confirm TO requirements, and acknowledge receipt and distribution of TO material.

This system provided more accurate and legible records. Additionally, the centralized automated distribution control system greatly facilitated TODO operations and resulted in both greater efficiency and manpower savings.

2. Centralized Data Management at the U.S. Air Force Logistics Command

The U.S. AFLC provides overall logistics management for the entire Air Force and its inventory, which includes management of money, facilities, equipment and personnel. Thus, the U.S. AFLC must be managed well to ensure the quality of the information, its timeliness, comprehensiveness, and accuracy.

The U.S. AFLC had about 35 different kinds of computer hardware systems. There were also some 15 different database management systems (DBMS), each of which had its own dictionary. To rectify this situation, the U.S. AFLC established a new Command Data Administration (CDA) division to set policy and support integration and standardization of the Command's data. [Ref. 19: p. 140]

The Systems and Applied Sciences Corporation (SASC) cooperated with the new division to design and implement the new Command Dictionary Directory (CD D) facility. The new CD D provided the control facility that allowed the U.S. AFLC to effect exact data administration by establishing a standardized database throughout the Command, and eliminating data redundancy.

The new CD D was developed using Computer Corporation of America's (CCA) Model 204 database management system. Model 204 provided the ability to handle a huge database with many concurrent users, a flexible structure that would permit dynamic growth, and a powerful fourth generation development and query

language. The SASC had modified the design of an encyclopedic database within Model 204. Under the new CD D, Model 204 handled the dictionary as a database. It included integrated files of meta-data on an IBM 4341 that will eventually enclose every data resource in the U.S. AFLC.

The Command is developing the new CD D in three phases. In the first phase, the CD D was loaded to convert and map the existing data element dictionary. In the second phase, standard logistics elements from the Department of Defense level will be compared to those that the U.S. Air Force now maintains. Finally, the U.S. AFLC will build two new systems for inclusion in the database; a new Stock Control and Distribution System and the Requirements Databank. Only the first phase was completed as of August, 1986.

C. AN EXAMPLE OF A DECENTRALIZED SYSTEM

The Pillsbury logistics system is composed of 12 distribution centers and 10 manufacturing plants with about 50,000 shipments per year. The Pillsbury Company's information system had been developed to track and record mostly financial data, and lacked the transactional information to optimize the logistics function. In order to improve this situation, the Pillsbury Company developed a microcomputer-based logistics information system. [Ref. 20: pp. 502-508]

The shipment tracking system was implemented using IBM XT computers or IBM-compatible with 20Mbyte storage. The microcomputer database system made it possible to analyze traffic patterns and keep track of carrier performance as well as provide information on daily transactions. The microcomputer provides enough storage for tracking 100,000 shipments. In addition, the system includes facilities such as a report generator that permits users who lack programming skills to design and run their own custom reports. The transportation staff uses the microcomputer directly to input the data as well as perform analyses and prepare reports.

The microcomputers were not connected to a mainframe, but the system was designed so that a network can be incorporated later. The microcomputer database provides information at the operational level in terms of the number of shipments, the average weight per shipment, the estimated cost per shipment, and the actual freight billed per shipment, etc.

A second application involves a Distribution Center based Stock Locator that runs on an IBM AT or IBM-compatible with 20Mbytes storage. The system is able to report exactly what inventory is on hand, where it is located, and the status of products by location.

D. EXAMPLES OF DISTRIBUTED SYSTEMS

Several companies have used logistics data interchanges which coordinate operations by using computer networks in order to reduce costs and make operations more efficient. [Ref. 21: pp. 173-177]

First, the Automotive Industry Action Group (AIAG) communications network is a typical third party logistics data interchange (LDI) arrangement organized in 1981 by all four major U.S. automobile manufacturers. They established standard forms and transmitting instructions for communications between automobile suppliers and their original equipment manufacturers (OEM), and developed their own communications regulations based on the American National Standards Institute (ANSI) X.12 standard transaction sets. Since the information requirements are limited, smaller suppliers with access to a microcomputer with communications capability were also able to access the network. This communication facility was expected to reduce supplier order receipt times, cut order processing costs dramatically, and move parts quickly.

Secondly, Ralph's Grocery Company is one of the oldest grocery businesses in the Western United States. They developed an inhouse automated network which automatically links product reorders from company warehouses and vendors to sales data recorded by checkout line product scanners. Their computers are connected to major suppliers' computers via direct communications linkages. All purchase order data is exchanged in Uniform Communications Standards formats. These formats have been widely adopted in the U.S. grocery industry. By using this network between the company and product suppliers, the Company can rapidly restock its distribution centers in response to depletion of products at the stores. As a result, it has achieved lower inventory holding and product ordering costs, as well as fewer stockouts of fast moving items.

Third, Volvo Transport AB of Sweden has established inhouse LDI communications networks to monitor and control inventory holdings and transportation product flows. These facilities allow them to control the flow of supplies in diversified stages of the logistics channels for all Volvo subsidiaries. By closely tracking materials and products between plants and customers, the company saves about \$28 million in excess inventory stocks each year. The company now plans to extend its LDI facilities to accommodate nonsubsidiary users.

Volvo is currently cooperating with Televerket (Sweden's state communications group) in introducing a new plan for an international LDI network capable of linking

many different types of computers. This new network will be able to plan, monitor, and document international freight shipments, arrangements for transportation carriers and customers clearances. Such networks will permit lower inventory costs by expediting shipments from origin to destination and by helping shippers to accurately track cargo movements.

Lastly, American Hospital Supply Inc., developed a direct electronic order system which connected it to large hospitals' computers in the mid-1970. The Company distributed products from 8,500 suppliers to over 100,000 health care locations. As a result, American Hospital has obtained high market shares by allowing customers direct linkages with vendors. The Company can also lower customer prices by using higher order volumes with suppliers. These LDI arrangements are designed to capture customers' orders by linking them directly to Company computers. Thus, this system is perceived as a major marketing innovation, and is instrumental in generating higher sales and improving customer service.

E. SUMMARY

This Chapter has reviewed the various computer-based logistics systems in both the military and commercial sectors. We saw how different organizations seek information system structures that are appropriate to meet their particular logistics objectives, for example transportation, warehousing, customer service, and materials handling.

V. RECOMMENDED MIS STRUCTURE FOR THE KOREAN AIR FORCE LOGISTICS ORGANIZATION

A. INTRODUCTION

Information system structure must be applied to meet organizational objectives for the utilization of the computer resource. In selecting an appropriate system structure model it is necessary, therefore, to examine the characteristics and goals of an organization. In Chapter II, the centralized and decentralized information systems concepts, advantages, and disadvantages were surveyed and discussed. Also, computer applications in the logistics area were discussed in Chapter IV. The purpose of the above Chapters was to review the general principles of information system structure and to understand the characteristics of the logistics applications in order to provide a basis for determining which information system structure would be the most appropriate for the Korean Air Force Logistics.

This chapter presents a specific methodology for selecting an appropriate information system structure for the Korean Air Force Logistics organization. It is based on the work of John F. Rockart, Christine V. Bullen, and Joav S. Leventer--all at MIT. [Ref. 22: pp. 12-36]

B. A FRAMEWORK FOR THE CENTRALIZATION/DECENTRALIZATION DECISION

The issue concerning centralization vs. decentralization has been ongoing in data processing circles since the appearance of the commercial computer in the early 1950s. The resolution of this issue, which involves the organization and control of the information systems function, is highly dependent on the characteristics, philosophies, and objectives of the organization.

The Center for Information Systems Research at MIT research team has been studying this issue, and have developed an approach to analyze the centralization decentralization dilemma. The methodology is based on actual experience, several in-depth studies, and a collection of published cases, in addition to the thorough survey of the literature.

The determination of centralization or decentralization need not be viewed as one simple decision. In deciding on centralization or decentralization, therefore, the methodology proposes a series of decisions which concern the different parts of the

information systems operation e.g., information systems function, logical application groups, and organizational sub-units. The components of the information systems function is delineated into three major dimensions: system development, operations, and management control. These components are defined as follows:

- System Development is the activity of designing and implementing new computerized information systems.
- Operations is the activity of running computerized information systems, such as operating and maintaining the hardware, accepting input, updating the files and databases, and generating reports.
- Management Control is the activity of managing the information system function, such as the setting of strategy, planning, setting standards, etc.

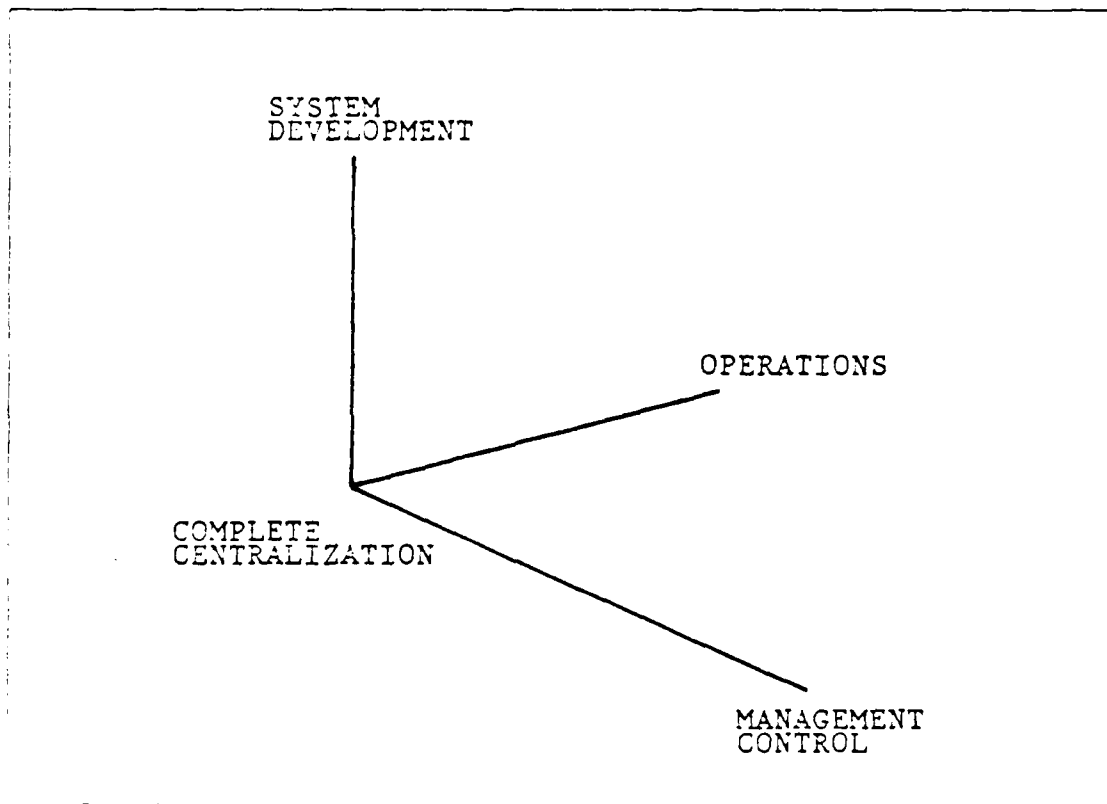

Figure 5.1 The Degree of Centralization and Decentralization.

Graphically, the three information systems dimensions are represented as a three dimensional space as shown in Figure 5.1. The origin represents complete centralization of all three functions. On the other hand, the degree of decentralization

of a given dimension is shown in terms of the distance from the origin along the appropriate axis.

Among the three components, management control is clearly different from system development and operations in both nature and scope. This is the overriding activity that provides direction to the entire information systems function. It involves the determination of what projects will be selected for development, what kind of equipment will be purchased, what software is standard, etc.

The decision to centralize or decentralize management control is a single decision that applies to the organization as a whole. This is not so for the other two dimensions. The MIT group recommends that centralization decentralization of system development and operations (the other two dimensions of Figure 5.1) be considered for each organization subunit and for each Logical Application Group (LAG) in the organization. A LAG is a logically separate cluster of activities that performed by the organization, such as inventory updating, credit checking, order editing, etc.

Each application or set of applications has its own characteristics and requirements. Because LAGs are relatively independent in both data and areas of concern, it is possible to treat them independently. Thus, centralization decentralization of system development and operations is considered for each single LAG at a time, since it is easier to deal with the characteristics of a single application area than the complex demands of the information system needs of an entire organization.

Large organizations tend to be divided into more than one sub-unit. A LAG may, therefore, concern one or more organizational sub-units. For example the inventory control LAG would be common to several plants in an organization. When the organizational units are different in their nature and characteristics, it is recommended that a separate decision be made for each unit.

This detailed breakdown of the centralization decentralization decision is represented in Figure 5.2. It shows the management control activity as a single decision for the entire organization. On the other hand, for system development and operations a separate centralization decentralization decision is made for each LAG, and each organizational unit.

In this thesis we will simplify the above elaborate framework. In particular, we will not break the logistics area into multiple LAGs or sub-units. This simplified model for the Korean Air Force Logistics system is shown in Figure 5.3.

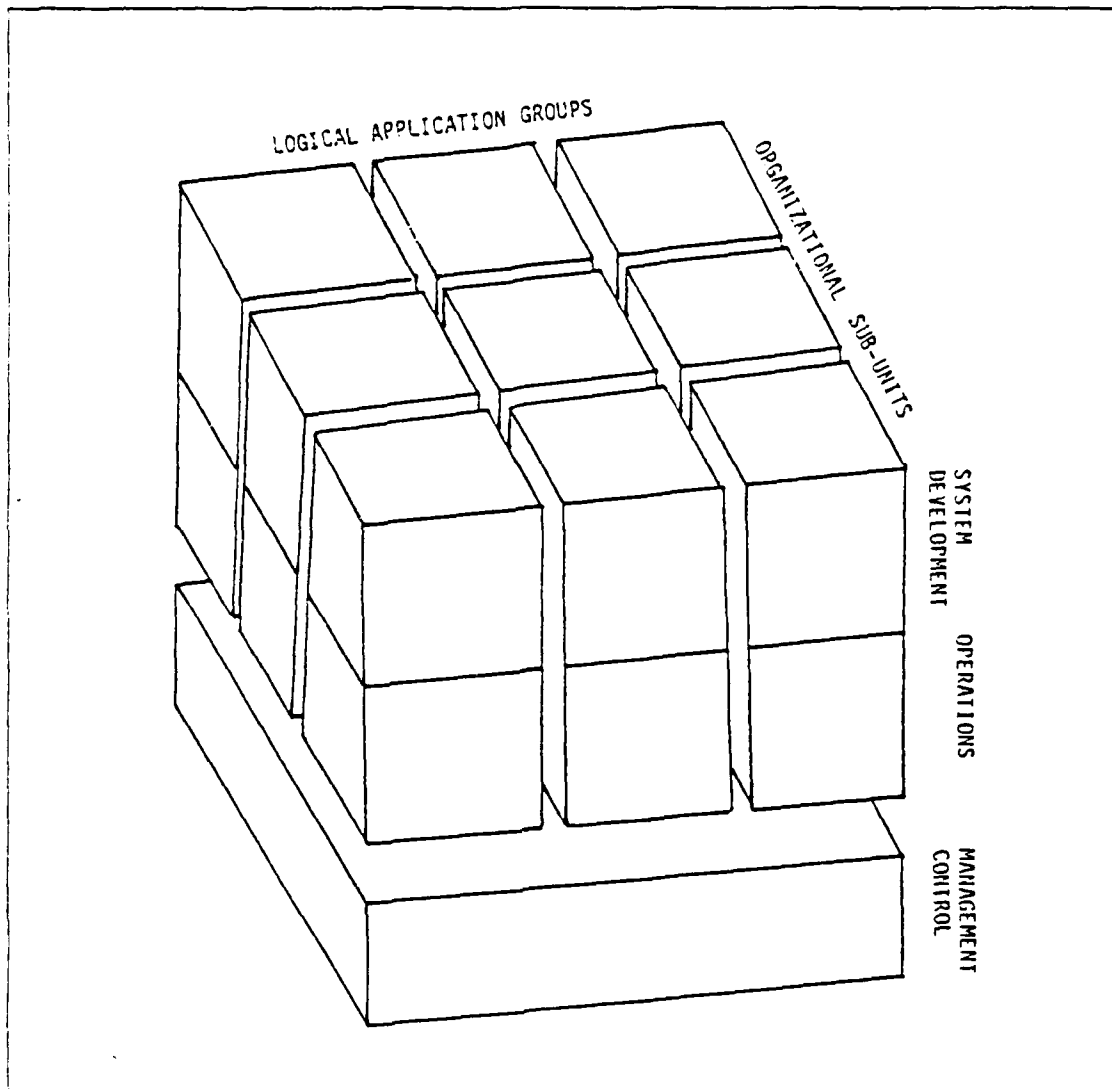

Figure 5.2 Breakdown of the Information Systems Function.

A analysis of the proper range of centralization/decentralization requires a closer understanding of the functional activities involved. To gain such an understanding, system development and operations activities are divided into sub-activities and resources. The sub-activities and resources identified, for each component, are discussed briefly below.

System development includes four sub-activities. These are: functional design, detailed specifications, programming, implementation, and maintenance. Each sub-activity is not necessarily centralized or decentralized to the same extent. But these

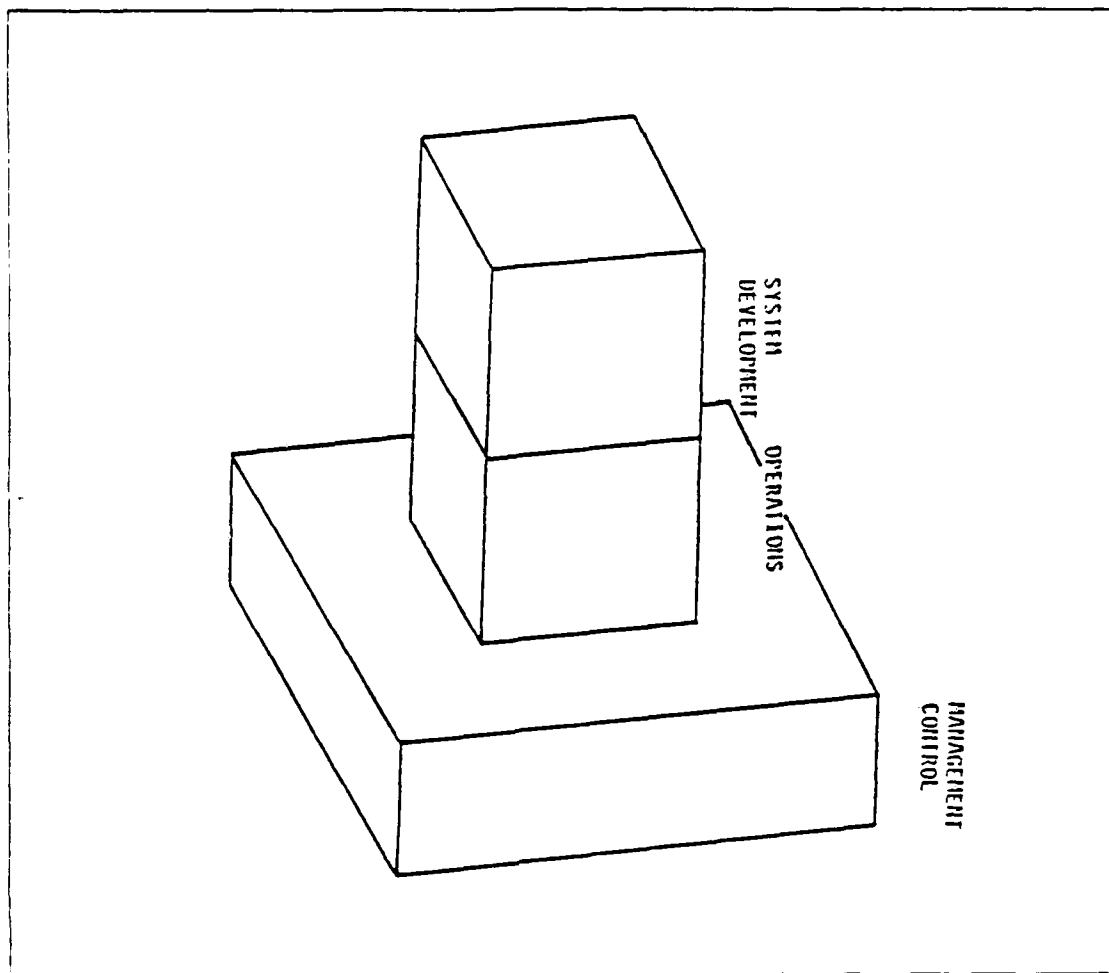

Figure 5.3 Basic Decision of Information Systems Function.

sub-activities are interrelated and considered in conjunction with each other. Personnel is the major resource used to perform these sub-activities of system development. Equipment and budget are an additional resource, but they are considered less important for a proper centralization decentralization decision.

The sub-activities for operations are edit and control, updating, processing, and reporting. These interrelated sub-activities cover the phases of the processing life cycle. Operations involves hardware, software, and personnel as one major group of resources.

Finally, management control sets the direction for the entire information systems function by setting standards and rules which control implementation. The managerial resources involved in performing management control are not considered here because these resources are rarely fully dedicated to this component.

The sub-activities and resources are considered as parts of the decision process for the determination of centralization decentralization. In each component, the various sub-activities are interrelated, and the centralization decentralization of one can affect the configuration of the others.

The final tool incorporated in the MIT methodology is the factor table. It is intended to structure each sub-activity and resource decision by listing a large set of factors that have an impact on the centralization decentralization decision. In their empirical studies, the research team delineated a large number of factors influencing the centralization and decentralization decision. This thesis will, however, utilize a modified version of this factor table to determine an effective MIS structure for Korean Air Force Logistics. The factor table used is presented in Table 2.

The table has three major sections. The first column applies a set of factors that impact the centralization decentralization decision. The second column indicates the direction which the factor implies in terms of centralization decentralization, and the strength of the factor. The strength is classified as "weak" or "strong". A strong rating indicates a greater impact on centralization decentralization decisions, while the converse is true for weak ratings. Finally, the remaining columns indicate the sub-activities or resources which we discussed above to which each factor applies.

In Table 2, circles (signifying centralization) and squares (signifying decentralization) exhibit two sizes; large, which indicates a strong strength, and small, which means a weak strength. These graphical means enable visual integration of the various considerations and their importance.

C. RECOMMENDED STRUCTURE FOR THE KOREAN AIR FORCE LOGISTICS ORGANIZATION

This section will present our application of the methodology for investigating the centralization or decentralization decision for the Korean Air Force Logistics organization. As mentioned above, this thesis presents a factor table which incorporates only those factors that are applicable to the Korean Air Force Logistics environment.

While all of the selected factors are significant, they don't, however, all have equal weights in determining the MIS structure. Thus, it is necessary to identify the highly significant factors in the Korean Air Force Logistics situation, and weigh them accordingly in the decision process.

TABLE 2
FACTOR TABLE

FACTOR	IMPLIES		SYSTEM DEVELOPMENT					OPERATIONS					MANAGEMENT CONTROL	
			subactivities			res.	subactivities			res.				
			functional design	detail specs & programming	implementation	maintenance	staff	edit & control	update	processing	reporting	h/w, s/w & staff		database
dir.	stren.													
GENERAL														
*centralized organization	cent.	strong	⊗	⊗	⊗	⊗	⊗	⊗	⊗	⊗	⊗	⊗	⊗	⊗
*uniformity of planning & control system	cent.	weak	⊗	⊗	⊗	⊗	⊗		⊗	⊗				⊗
NATURE OF DIVISION TASK														
*highly specialized tasks	decent.	strong	⊗		⊗			⊗	⊗	⊗	⊗		⊗	⊗
*dependent	cent.	weak	○	○	○		○	○	○	○	○	○	○	
OTHER FACTORS														
*large organization	decent.	strong	□	□	□	□	□	□	□	□	□	□	□	
*low experience with DP	cent.	weak	○	○	○	○	○	○	○	○	○	○	○	
NATURE OF APPLICATION														
*highly sensitive & critical for each division	decent.	weak	⊗		⊗	⊗		⊗			⊗	⊗	⊗	
SPECIFIC REQUIREMENTS														
*reliability or lack of vulnerability critical	decent.	strong						⊗	⊗	⊗	⊗	⊗	⊗	
*response or turn-around time critical	decent.	strong						□	□		□	□	□	
PROCESSING REQUIREMENTS														
*task complexity	cent.	weak	○					○	○	○	○	○	○	
*custom tailoring required	decent.	weak	□		□			□			□	□		
*use of database technology	cent.	weak	⊗		⊗				⊗	⊗		⊗	⊗	
*large memory required intermittently	cent.	strong						○	○	○	○	○	○	

- Centralized, strong
i.e. complete decentralization is undesirable
- Centralized, weak
- Decentralized, strong
i.e. complete centralization is undesirable
- Decentralized, weak

The highly dominant factors in the Korean Air Force Logistics environment based on the author's experience are the following: centralized organization, uniformity of planning and control, highly specialized tasks, application highly sensitive and critical, reliability or lack of vulnerability, and use of database technology. These factors are identified with an 'x' inside the square or circle in Table 2.

1. System Development

a. Functional Design

Based on the analysis of Table 2, the recommended structure is to centralize functional design. There are six factors that suggest centralization. They are: "centralized organization", "uniformity of planning and control system", "dependency of tasks between division", "low experience with DP", "task complexity", and "use of database technology". Of these, the dominant factor is the "centralized organization", whose impact is strong (signified by the large circle). The factors suggesting decentralization, on the other hand, are only three, namely, "highly specialized tasks", "large organization", and "application highly sensitive and critical for each division". Of these, the "highly specialized nature of task" is a dominant factor.

b. Detail Specs and Programming

This sub-activity indicates a high degree of centralization. There are four factors that indicate centralization which are: "centralized organization", "uniformity of planning and control system", "dependency of tasks between division", and "low experience with DP". One is a dominant factor within them, the "centralized organization", whose impact is strong (indicated by the large circle). On the other hand, the single factor indicating decentralization is a "large organization".

c. Implementation

This sub-activity provides a challenge, since the arguments for centralization are almost balanced by arguments for decentralization. The recommended structure is, however, to centralize because the above two phases of the life cycle were centralized. There are five factors that indicate centralization. They are: "centralized organization", "uniformity of planning and control system", "dependency of tasks between division", and "low experience with DP". Of these, one is a dominant factor, the "centralized organization". It has a strong impact (signified by the large circle). Also, there are four factors that indicate decentralization: "highly specialized tasks", "large organization", "application highly sensitive and critical for each division", and "custom tailoring required". Of these, one is a dominant factor, the "highly specialized nature of task".

d. Maintenance

This sub-activity, based on the analysis of Table 2, favors centralization. There are three factors that indicate centralization, "centralized organization", "uniformity of planning and control system", and "low experience with DP". The dominant factor among them, the "centralized organization", has a strong impact (indicated by the large circle). On the other hand, there are two nondominant factors that indicate decentralization which are: "large organization", and "application highly sensitive and critical for each division".

e. Staff

The factors affecting the staff, as a resource, indicate a high degree of centralization. There are four factors that imply centralization which are: "centralized organization", "uniformity of planning and control system", "dependency of tasks between division", and "low experience with DP". Of these, one is a dominant factor, the "centralized organization", and it has a strong impact (signified by the large circle). On the other hand, there is only one factor that suggests decentralization, which is the "large organization".

2. Operations

a. Edit and Control

It is recommended that this activity be decentralized. There are six factors that suggest decentralization: "highly specialized tasks", "large organization", "application highly sensitive and critical for each division", "reliability or lack of vulnerability critical", "response or turnaround time critical", and "custom tailoring required". Two are dominant factors, namely, "highly specialized tasks", and "reliability or lack of vulnerability critical". Both have a strong impact (indicated by the large square). Also, there are five factors that suggest centralization, they are: "centralized organization", "dependency of tasks between division", "low experience with DP", "task complexity", and "large memory required intermittently". Of these, only one is a dominant factor, the "centralized organization".

b. Update

Based on the analysis of Table 2, the recommended structure is to decentralize. There are four factors that indicate decentralization. They are: "highly specialized tasks", "large organization", "reliability or lack of vulnerability critical", and "response or turnaround time critical". Of these, two are dominant factors, namely, the "highly specialized tasks" and "reliability or lack of vulnerability critical". Both have a

strong impact (signified by the large square). On the other hand, there are seven factors that imply centralization, they are: "centralized organization", "uniformity of planning and control system", "dependency of tasks between division", "low experience with DP", "task complexity", "use of database technology", and "large memory required intermittently". Of these, only one is a dominant factor, the "centralized organization".

c. Processing

The analysis slightly favors centralization. In considering the current Korean Air Force Logistics situation, both the "reliability or lack of vulnerability critical" which implies decentralization and "use of database technology" which typically implies centralization are particularly important in determining the centralization decentralization decision. However, as technology advances in the distributed database area, the centralization implication of the database issue is decreasing in significance (at least one distributed database system, SDD-1⁴ by Computer Corporation of America, is already operational). Thus, we recommend that this activity be decentralized. There are three factors that suggest decentralization which are: "highly specialized tasks", "large organization", and "reliability or lack of vulnerability critical". Of these, two are dominant factors, the "highly specialized tasks" and "reliability or lack of vulnerability critical". Both have a strong impact (signified by the large square). Also, there are seven factors that indicate centralization, they are: "centralized organization", "uniformity of planning and control system", "dependency of tasks between division", "low experience with DP", "task complexity", "use of database technology", and "large memory required intermittently". Only one is a dominant factor, the "centralized organization".

d. Reporting

This sub-activity, based on the analysis of Table 2, needs to be decentralized. There are six factors that suggest decentralization which are: "highly specialized tasks", "large organization", "application highly sensitive and critical for each division", "reliability or lack of vulnerability critical", "response or turnaround time critical", and "custom tailoring required". Of these, two are dominant factors, namely, the "highly specialized tasks" and "reliability or lack of vulnerability critical". Both have a strong impact (signified by the large square). Also, there are five factors

⁴This system achieves update synchronization by means of several different "synchronization protocols" which vary in cost and which offer varying levels of synchronization control.

that imply centralization, they are: "centralized organization", "dependency of tasks between division", "low experience with DP", "task complexity", and "large memory required intermittently". Only one is a dominant factor, the "centralized organization".

e. Hardware, Software and Staff

The analysis indicate balance weighting for both centralization and decentralization. The particularly critical factors for the Korean Air Force Logistics are: "application highly sensitive and critical for each division", "reliability or lack of vulnerability critical", and "response or turnaround time critical". These factors indicate decentralization, and hence, this resource needs to be decentralized. There are five factors that suggest decentralization. They are: "large organization", "application highly sensitive and critical for each division", "reliability or lack of vulnerability critical", "response or turnaround time critical", and "custom tailoring required". Of these, one is a dominant factors, "reliability or lack of vulnerability critical", which has a strong impact (signified by the large square). Also, there are six factors that indicate centralization, "centralized organization", "dependency of tasks between division", "low experience with DP", "task complexity", "use of database technology", and "large memory required intermittently". Of these, only one is a dominant factor, the "centralized organization".

f. Database

Based on the analysis of Table 2, this resource needs to be decentralized. There are five factors that show decentralization is appropriate. They are: "highly specialized tasks", "large organization", "application highly sensitive and critical for each division", "reliability or lack of vulnerability critical", and "response or turnaround time critical". Of these, two are dominant factors, "highly specialized tasks" and "reliability or lack of vulnerability critical". Both have a strong impact (signified by the large square). On the other hand, there are six factors that suggest centralization, "centralized organization", "dependency of tasks between division", "low experience with DP", "task complexity", "use of database technology", and "large memory required intermittently". Of these, only one is a dominant factor, the "centralized organization".

3. Management Control

This function sets the standards and rules, and controls their implementation e.g., choice, programming standards, etc. This function needs to be centralized. There are two factors that imply centralization, they are: "centralized organization", and "uniformity of planning and control system". One is a dominant factor, namely, the

"centralized organization", and it has a strong impact (signified by the large circle). The single factor suggesting decentralization, on the other hand, is "highly specialized tasks".

D. CONCLUSION

The effective MIS structure for the Korean Air Force Logistics as indicated by the results of the above analysis, is one in which system development is centralized, operations is decentralized, and management control is centralized. This model, we feel, would be the most appropriate for the Korean Air Force Logistics organization, and is shown in Figure 5.4.

The advantages of this proposed structure for the Korean Air Force Logistics organization are summarized below:

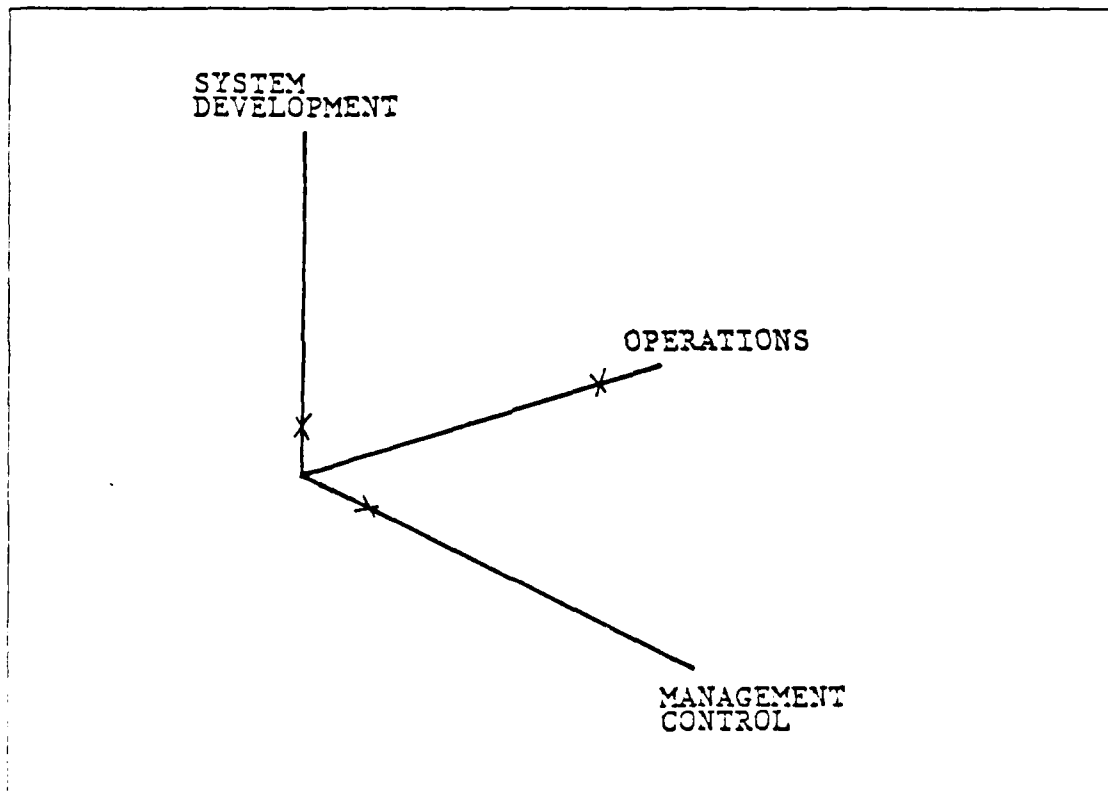

Figure 5.4 Proposed MIS Structure for the Korean Air Force Logistics Organization.

1. Benefits of Centralizing System Development

- Attract high quality professionals.
- More sophisticated applications.
- Allows better training programs.
- Avoid redundancy of development efforts.
- High quality software, low maintenance cost.
- Quality documentation.

2. Benefits of Decentralizing Operations

- Lower communication cost.
- Better reliability.
- Faster response time to user needs.
- Less errors in data entry.
- Good user interfaces.

3. Benefits of Centralizing Management Control

- Allows better control which includes standards for programming, equipment, operation, and interconnection.
- Negotiating power in purchasing in large volume.
- Ability to attract high quality managers for data processing.
- Avoid costs of incoherence.
- An increased ability to implement and follow master plans.
- Better overall evaluation of projects for technical, economic, operational and schedule feasibility.

VI. SUMMARY AND DIRECTIONS FOR FUTURE RESEARCH

A. THESIS SUMMARY

To meet our objective of defining an appropriate MIS structure for the Korean Air Force logistics organization, we first studied the system currently used to maintain air force readiness and support tactical aviation. We then discussed the organization, mission, and management philosophy of the logistics MIS system used to support that organization.

In Chapter II we provided a general discussion of the advantages and disadvantages of centralized and decentralized information system structures. Historically, centralization of the computer resource was favored by organizations in order to reduce costs. Decentralized structure, on the other hand, appeals to organizations with heterogenous user groups requiring flexible, responsive system applications.

In Chapter III an overview of the Korean Air Force Logistics MIS was presented. The Korean Air Force Logistics MIS was implemented to computerize the logistics system procedures. It is an essential part of the operation of aviation logistics. However, the current Korean Air Force Logistics MIS has serious deficiencies in terms of the MIS service provided. These were identified and discussed in Chapter III.

In Chapter IV several computer applications in the logistics area were discussed in terms of the centralization, decentralization, and distribution of their structure. It was pointed out that different organizations seek information system structures that are appropriate to meet their particular logistics objectives.

In Chapter V a methodology was selected to analyze the centralization decentralization decision for the Korean Air Force Logistics organization. This model structures the centralization and decentralization decision into three major dimensions: system development, operations, and management control. The various components are of course interrelated, and the centralization decentralization of one can affect the configuration of the others.

As a result of the analysis we performed using the model, we concluded that the most effective MIS structure for the Korean Air Force Logistics organization is one in which system development and management control are centralized while operations are decentralized.

B. SUGGESTIONS FOR FUTURE RESEARCH

This thesis is largely based on the author's own experience. This, undoubtedly, is a limited data source. A major extension to this work would be to conduct a comprehensive data collection exercise of perceived problems (from both MIS personnel as well as users) and of the technical characteristics (e.g., response time, reliability) of the continually evolving MIS system. This would provide the basis for a more elaborate as well as a more accurate evaluation of all the factors involved in the centralization and decentralization decision.

Another research direction would be to study the opportunities and impacts of end-user computing on the Korean Air Force Logistics organization. In an end-user computing environment, users are provided with terminals and powerful software for accessing data, and performing information processing directly. End-user computing is a significant force for change in the way information resources are organized, provided and used. As such it can have a direct impact on the issues concerning centralization and decentralization.

In this thesis we considered a simplified organizational environment composed of a single Logical Application Group (LAG). A future study could relax this simplifying assumption and explicitly incorporate the differences between the different logistics subfunctions: requirements, procurement and acquisition, distribution, maintenance, and disposal.

LIST OF REFERENCES

1. Davis, G. B. and Olson, M. H., *Management Information Systems: Conceptual Foundations, Structure and Development, 2nd ed.*, McGraw-Hill Book company, New York, 1985.
2. Walsh, Myles S., "MIS-Where are we, How did we get here and Where are we going?", *Journal of Systems Management*, vol 29, no 11, pp. 6-21, November 1978.
3. Martin, James, *Design and Strategy for Distributed Data Processing*, Prentice-Hall, Inc., Englewood Cliffs, New Jersey, 1981.
4. Buchanan, Jack R. and Linowes Richard G., "Understanding distributed data processing", *Harvard Business Review*, vol 58, no 4, pp.143-153, July-August 1980.
5. Riley, M. J., *Management Information Systems, 2nd ed.*, Holden-Day, Inc., San Francisco, 1981.
6. Ahituv, Niv and Neumann, Seev, *Principles of Information Systems for Management*, Wm. C. Brown publishers, Dubuque, Iowa, 1986.
7. Statland, N., "Organizing your company's EDP Centralization vs. Decentralization", *Price Waterhouse Review*, vol 20, no 2, pp.12-17, 1975.
8. Burch, J. G., Jr., Strater, F. R., and Grudnitski, G., *Information Systems: Theory and Practice, 2nd ed.*, John Wiley&Sons, Inc., Toronto, 1979.
9. Lorin, Harold, *Aspects of Distributed Computer Systems*, John Wiley & Sons, Inc., Toronto, 1980.
10. Wetherbe, James C., "Is: To Centralize or to Decentralize", *SIM Network*, vol 1, pp. 1-3, January 1987.
11. Humfrey, R. D., "Centralization of EDP services-Organizational consideration", *Canadian Chartered Accountant*, vol 103, no 1, pp. 39-43, July 1973.
12. Reynolds, Carl H., "Issues in Centralization", *Datamation*, vol 23, no 3, pp. 1-100, March 1977.

13. Diamond, Sidney, "DDP vs. Centralization: A Decision-Making Model", *Systems, Objectives, Solutions*, vol 2, no 4, pp. 229-240, November 1982.
14. Muray, John p., "Distributing centralized data entry function", *Computerworld*, vol 18, no 13, p. 57, March 26, 1984.
15. Keider, Stephen P., "Once again-centralize or decentralize", *Infosystems*, pp. 40-42, vol 23, no 12, December 1976.
16. AUERBACH Publishers Inc., *Centralization: "To Be or Not To Be?"*, New York, 1976.
17. Capt. Jang, Dong Ryul, Korean Air Force Logistics Center Electronic Data Processing Center, letter, subject: *EDPC mission statement*, December 1986.
18. King, Gerard F., "Automating Wing and Squadron Level Technical Order Distribution Control", *Logistics Spectrum*, pp. 32-35, vol 15, no 4, Winter 1981.
19. Duffy, George and Cain, Larney, "New Division at Logistics Command to Integrate Data", *Government Computer News*, p. 140, vol 5, no 17, August 29, 1986.
20. Chatterjee, Subir K., "Microcomputer Based Logistics Information Systems", *The Logistics and Transportation Review*, pp. 502-508, vol 20, no 4, December 1984.
21. David Anderson, Temple, Barker, and Sloane Inc., "Case studies and implementations of LDI arrangements", *Data Communications*, pp. 173-182, vol 15, no 2, February 1986.
22. Rockart, John F., Bullen, Christine V. and Leventer, Joav S., *Centralization vs. Decentralization Information Systems: A Preliminary Model for Decision Making*, Center for Information Systems Research, Massachusetts, April 1977.

INITIAL DISTRIBUTION LIST

		No. Copies
1.	Defense Technical Information Center Cameron Station Alexandria, VA 22304-6145	2
2.	Library, Code 0142 Naval Postgraduate School Monterey, CA 93943-5002	2
3.	Department Chairman, Code 54 Dept. of Administrative Sciences Naval Postgraduate School Monterey, CA 93943-5004	1
4.	Prof. T. K. Abdel-Hamid, Code 54AH Naval Postgraduate School Monterey, CA 93943-5004	2
5.	Prof. R. A. McGonigal, Code 54MB Naval Postgraduate School Monterey, CA 93943-5004	2
6.	Air Force Central Library Sindaebang-Dong, Kwanak-Ku, Seoul Republic of Korea 151-00	3
7.	Library of Air Force Academy Chongwon-Kun, Chung Buk Republic of Korea 370-72	3
8.	Park Byung kil Soung Shim House #101 19 8, 337-6 Bukgajoa-2Dong Sedaemun-Ku, Seoul Republic of Korea 120-00	5
9.	LTCOL Ma Soonpok HQ AFLC MI-KS WP AFB, OH 45433	1
10.	Richard Saccone AFOSI District 45 APO S.F. 96301	1

END

10-87

DTIC