

AD-A185 074

18 June 1967

National Aeronautics and
Space Administration



Jet Propulsion Laboratory
California Institute of Technology
Pasadena, California

JPLD-4304
ALGD_PUB_0000

This document has been approved
for public release and sale; its
distribution is unlimited.

DTIC
ELECTE
SEP 24 1967
S A D

87 7 2 078

REPORT DOCUMENTATION PAGE		READ INSTRUCTIONS BEFORE COMPLETING FORM
1. REPORT NUMBER ALGO-PUB-0030	2. GOVT ACCESSION NO.	3. RECIPIENT'S CATALOG NUMBER
4. TITLE (and Subtitle) Technical Memo 16, "ELINT Sensor Parameterization and Definition, Interim Report #1."		5. TYPE OF REPORT & PERIOD COVERED FINAL
		6. PERFORMING ORG. REPORT NUMBER D-4304
7. AUTHOR(s) B. BUCKLES		8. CONTRACT OR GRANT NUMBER(s) NAS7-918
9. PERFORMING ORGANIZATION NAME AND ADDRESS Jet Propulsion Laboratory ATTN: 171-209 California Institute of Technology, 4800 Oak Grove, Pasadena, CA 91109		10. PROGRAM ELEMENT, PROJECT, TASK AREA & WORK UNIT NUMBERS RE 182 AMEND #187
11. CONTROLLING OFFICE NAME AND ADDRESS Commander, USAICS ATTN: ATSI-CD-SF Ft. Huachuca, AZ 85613-7000		12. REPORT DATE 19 Jun 85
		13. NUMBER OF PAGES 35
14. MONITORING AGENCY NAME & ADDRESS (if different from Controlling Office) Jet Propulsion Laboratory ATTN: 171-209 California Institute of Technology 4800 Oak Grove, Pasadena, CA 91109		15. SECURITY CLASS. (of this report) UNCLASSIFIED
		15a. DECLASSIFICATION/DOWNGRADING SCHEDULE NONE
16. DISTRIBUTION STATEMENT (of this Report) Approved for Public Dissemination		
17. DISTRIBUTION STATEMENT (of the abstract entered in Block 20, if different from Report)		
18. SUPPLEMENTARY NOTES Prepared by Jet Propulsion Laboratory for the US Army Intelligence Center and School's Combat Developer's Support Facility.		
19. KEY WORDS (Continue on reverse side if necessary and identify by block number) Modeling, Superheterodyne Radar, FORTRAN, Video, CFAR, FFT, Low Bandpass Filter, Frequency, SNR		
20. ABSTRACT (Continue on reverse side if necessary and identify by block number) This memo describes the modeling of the superheterodyne radar receiver and defines the parameters of interest. The modeling details are included. Both a flow chart and source code (FORTRAN) for the model are included. The report ends with documentation of the model testing and validation.		

U.S. ARMY INTELLIGENCE CENTER AND SCHOOL
Software Analysis and Management System

ELINT SENSOR PARAMETERIZATION AND DEFINITION
INTERIM REPORT # 1

EAAF

Technical Memorandum No. 16

19 June 1987

Author:

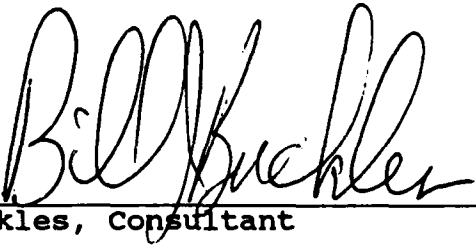

Bill Buckles, Consultant

Approval:

James W. Gillis, Subgroup Leader
Algorithm Analysis Subgroup

for 
Edward J. Records, Supervisor
USAMS Task

Concur:

A. F. Ellman, Manager
Ground Data Systems Section

Fred Vote, Manager
Advanced Tactical Systems

JET PROPULSION LABORATORY
California Institute of Technology
Pasadena, California

The work described in this publication was sponsored by the United States Army Intelligence Center and School. The writing and publication of this paper was supported by the Jet Propulsion Laboratory, California Institute of Technology, under a contract with the National Aeronautics and Space Administration, NAS 7-918, RE 182, A187.

1951 1952 1953 1954 1955 1956 1957 1958 1959 1960 1961 1962 1963 1964 1965 1966 1967 1968 1969 1970 1971 1972 1973 1974 1975 1976 1977 1978 1979 1980 1981 1982 1983 1984 1985 1986 1987 1988 1989 1990 1991 1992 1993 1994 1995 1996 1997 1998 1999 2000 2001 2002 2003 2004 2005 2006 2007 2008 2009 2010 2011 2012 2013 2014 2015 2016 2017 2018 2019 2020 2021 2022 2023 2024 2025

ELINT SENSOR PARAMETERIZATION AND DEFINITION INTERIM REPORT # 1

FOREWARD

Interim report # 1 describes progress to date of the ELINT Parameterization and Definition Study. The introduction describes the purpose of the study and explains why it was decided to model a superheterodyne receiver and defines the parameters of interest. A description of the model follows in section 2. A flow diagram and the source code of the model are included in sections 3 and 4 respectively. The report is concluded with documentation of results and conclusions in section 5.

Accession For	
DTIC	<input checked="" type="checkbox"/>
ERIC	<input type="checkbox"/>
NTIS	<input type="checkbox"/>
Unannounced	<input type="checkbox"/>
<i>Added to file</i>	
By _____	
Distribution/	
Availability Codes	
Dist	Avail and/or Special
<i>All</i>	

DTIC
COPY
INSPECTED
6

EXECUTIVE SUMMARY

This Technical Memorandum was prepared originally as part of the Generic ELINT/COMINT Sensor Report (FY-85/FY-86) which was eliminated under the FY-87 statement of work (SOW #2), undated (delivered to JPL 19 November 1986).

The purpose of the Generic ELINT/COMINT Sensor Report, of which this paper was intended (in its final form) to become part of, was to establish a basic superhetrodyne receiver based sensor model and perform simulations with it to determine the shaping or coloring of the statistical distributions of the radar free-space signal parametrics by a typical sensor prior to reaching the self-correlation processes. It was also intended for incorporation into the algorithm test bed so algorithms could be tested with realistic distorted data rather than unrealistic stastically pure data.

This work was originated in support of unanswered questions from previous self-correlation studies. The modeling and simulation approach was used because "live date" could not be obtained.

This paper is being published because it was completed in FY-86 with FY-86 funds and still serves a useful function.

There were no unexpected results at this stage of the models development - the model has been verified as valid. The second stage of this study is to analyze the shaping or coloring of the radar free-space signal parametrics and may not be completed due to the restrictions of the current JPL Task Plan.

ELINT SENSOR PARAMETERIZATION AND DEFINITION INTERIM REPORT # 1

- 0.0 EXECUTIVE SUMMARY
- 1.0 INTRODUCTION

- 2.0 RECEIVER MODEL DEVELOPMENT
 - 2.1 SQUARE LAW DETECTOR AND LOW PASS DETECTOR
 - 2.2 VIDEO AMPLIFIER
 - 2.3 CONSTANT FALSE ALARM RATE (CFAR)
 - 2.4 PULSE DETECTOR
 - 2.5 LIMITER
 - 2.6 DISCRIMINATOR

- 3.0 RECEIVER PROGRAM FUNCTIONAL FLOWCHART

- 4.0 SOURCE CODE

- 5.0 RESULTS AND CONCLUSIONS

ELINT SENSOR PARAMETERIZATION AND DEFINITION INTERIM REPORT * 1

1.0 INTRODUCTION

The purpose of this report is to define the statistics of the observed parameters of interest of a generic ELINT sensor. The approach chosen was to "build" a computer model of a typical ELINT receiver and excite it with input signals of known distributions and then measure the resulting output distributions.

1.1 THE "SUPERHET"

The superheterodyne receiver has many advantages to offer for the gathering of electronic intelligence. It is the most widely used receiver design for nearly all uses including ELINT applications. A basic functional block diagram is shown in Figure 1.1. The idea is to use a local oscillator to convert the incoming signal to a fixed intermediate frequency (IF) by the mixing process called heterodyning. Thus the IF amplifier need operate at only one (lower) frequency and it's operating characteristics may be carefully and more economically controlled. Bandwidths for typical narrowband ELINT receivers are approximately 20 MHz for B_{RF} or B_{IF} and 10 MHz for B_V . This ensures good pulse fidelity for nominal radar pulsewidths of 1 microsecond or greater. The simple receiver of Figure 1.1 has been used with great success since World War II. Recent innovations have greatly increased the basic capability of the superhet. By rapidly sweeping the local oscillator in frequency an amplitude versus frequency display may be generated thus creating an RF spectrum analyzer. Very rapid sweeping creates a rapid sweep superhet that is useful for detecting high duty cycle, low power signals in the presence of low duty cycle interfering signals*. In addition heterodyning techniques are used in the implementation of compressive and microscan receivers and many instantaneous frequency measurement (IFM) receiver designs utilize superhet frontends.

So we see that the study of superhet receivers is a good place to begin.

* R. G. WILEY, *ELECTRONIC INTELLIGENCE: THE INTERCEPTION OF RADAR SIGNALS*

ELINT SENSOR PARAMETERIZATION AND DEFINITION INTERIM REPORT # 1

2.0 SENSOR MODEL DEVELOPMENT

Figure 2.1 is a functional block diagram of the simple receiver to be modeled. We first assume that the received signal is a narrowband process that is statistically unaltered by the downconversion to the IF frequency, ω_{IF} . Thus, the signal at the input of the detector and limiter is

$$(1) \quad r(t) = s(t) \cos[(\omega_c - \omega_o)t + \phi(t)] + n(t) \quad \text{where}$$

$s(t)$ = transmitted pulse envelope as modified by the transmission channel characteristics

ω_c = carrier frequency

ω_o = LO frequency assumed to be noiseless

$\omega_{IF} = \omega_c - \omega_o$ = IF frequency

$\phi(t)$ = signal phase at output of IF amplifier

$n(t)$ = additive receiver noise plus input noise.

ELINT SENSOR PARAMETERIZATION AND DEFINITION INTERIM REPORT # 1

2.1 SQUARE LAW DETECTOR AND LOW PASS FILTER

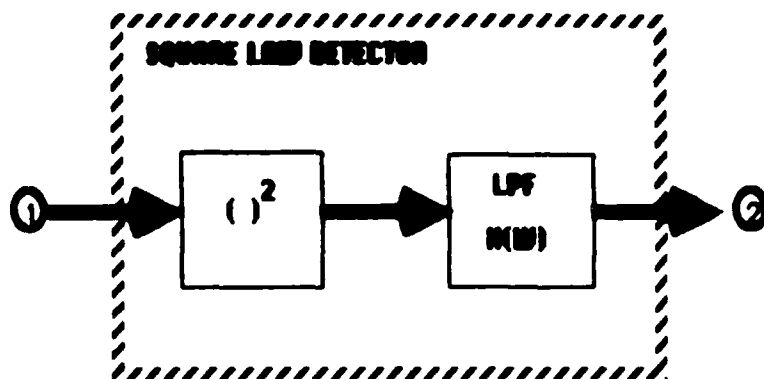

FIGURE 2.2 . Functional Block Diagram of a Square Law Detector

Figure 2.2 depicts functionally a square law detector. Squaring the input (1) above, we obtain

$$r^2(t) = s^2(t) \cos^2[2\pi f_{IF}t + \phi(t)] + 2s(t) \{\cos[2\pi f_{IF}t + \phi(t)]\} n(t) + n^2(t) \quad (1.1)$$

where $f_{IF} = 2\pi(\omega_C - \omega_0)$ is the receiver IF frequency.

Now, using

$$\cos^2 x = 1/2 (1 + \cos 2x)$$

(1.1) becomes

$$r^2(t) = 1/2 s^2(t) + 1/2 s^2(t) \cos 2[2\pi f_{IF}t + \phi(t)] + 2s(t) \{\cos(2\pi f_{IF}t + \phi(t))\} n(t) + n^2(t) \quad (1.2)$$

ELINT SENSOR PARAMETERIZATION AND DEFINITION INTERIM REPORT # 1

Hence, by multiplying the received signal by itself we have obtained $1/2$ the square of the modulation waveform $s(t)$ plus higher frequency terms consisting of cross products of the noise and the signal at the fundamental and second harmonic frequencies and the noise term $n^2(t)$. Now, by low pass filtering the output of the square law device as depicted in the above figure with a filter sufficiently wide to pass $s(t)$ while rejecting those frequencies above the lowest component of $s(t)$ that is of interest. One obtains at the output of the detector low pass filter the signal

$$(2) \quad r_v^2(t) = 1/2 s^2(t) + \hat{n}^2(t)$$

where $\hat{n}^2(t)$ represents the low frequency components of the noise process $n^2(t)$.

For the purpose of this simulation the output filter of the detector will determine the bandpass response of the video channel. Good pulse fidelity requires that the filter have a bandpass adequate to pass the 12th harmonic with less than 75% attenuation*. Thus the filter is required to have a 3db bandwidth B_{3db} greater than or equal to 12 Mhz, assuming that the received pulse width is greater than or equal to 1 μ sec.

* R. G. WILEY, *ELECTRONIC INTELLIGENCE: THE ANALYSIS OF RADAR SIGNALS*

ELINT SENSOR PARAMETERIZATION AND DEFINITION INTERIM REPORT # 1

2.2 VIDEO AMPLIFIER

The video amplifier provides additional gain and bandpass shaping if required. For this simulation the gain will be set to K with an infinite frequency response. Thus, the bandpass response of this portion of the receiver is determined by the low pass filter of the detector and

$$A(\omega) = K$$

where K is selectable as a user input into the simulation and defaults to the value required to provide unity gain to the detector and, thereby, simplifying later calculations.

2.3 CONSTANT FALSE ALARM RATE (CFAR)

The CFAR is a circuit that maintains a reference voltage level proportional to the received in band noise. Thus, it may be used to vary the threshold of the pulse detection circuitry in such a way to prevent false alarms due to varying noise levels at the input of the receiver. The CFAR constant, C, is adjusted to provide a desired false alarm rate (FAR). The results reported herein were based upon a calculated FAR = 10^{-4} .

2.4 PULSE DETECTOR

The pulse detector circuitry compares the output of the video amplifier to the threshold determined by the CFAR circuit and strobes a pulse present signal to the parameter estimation circuit when the video signal is greater than the threshold. A threshold is chosen to provide a desired probability of detection (P_D).

ELINT SENSOR PARAMETERIZATION AND DEFINITION
INTERIM REPORT # 1

2.5 LIMITER

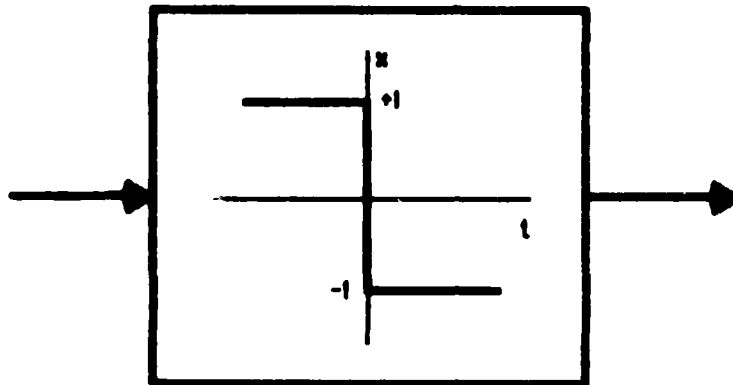

FIGURE 2.3. FUNCTIONAL BLOCK DIAGRAM OF A HARD LIMITER

A functional block diagram of a hard limiter is depicted in Figure 2.3. The limiter conditions the input signal to the frequency discriminator by amplifying and clipping an I.F. output signal to provide essentially a square wave input to the discriminator at the frequency of the IF signal. If the input to a hard limiter is $x(t)$ then the output, $y(t)$, is

$$y(t) = \begin{cases} 1 & x(t) \geq 0 \\ -1 & x(t) < 0 \end{cases}$$

ELINT SENSOR PARAMETERIZATION AND DEFINITION INTERIM REPORT # 1

2.6 DISCRIMINATOR

The discriminator provides the frequency estimation function for the receiver. It consists of a zero crossing counter that counts and stores the number of zero crossings during the pulse. When the threshold circuit detects a pulse it provides a strobe that initializes and starts the zero crossing counter. At the end of the pulse the contents of the counter are read and the average frequency of the I.F. pulse is calculated based upon the estimated pulsewidth.

**ELINT SENSOR PARAMETERIZATION AND DEFINITION
INTERIM REPORT # 1**

3.0 SENSOR MODEL FUNCTIONAL FLOW CHART

801
802
803
804
805
806
807
808
809
810
811
812
813
814
815
816
817
818
819
820
821
822
823
824
825
826
827
828
829
830
831
832
833
834
835
836
837
838
839
840
841
842
843
844
845
846
847
848
849
850
851
852
853
854
855
856
857
858
859
860
861
862
863
864
865
866
867
868
869
870
871
872
873
874
875
876
877
878
879
880
881
882
883
884
885
886
887
888
889
890
891
892
893
894
895
896
897
898
899
900

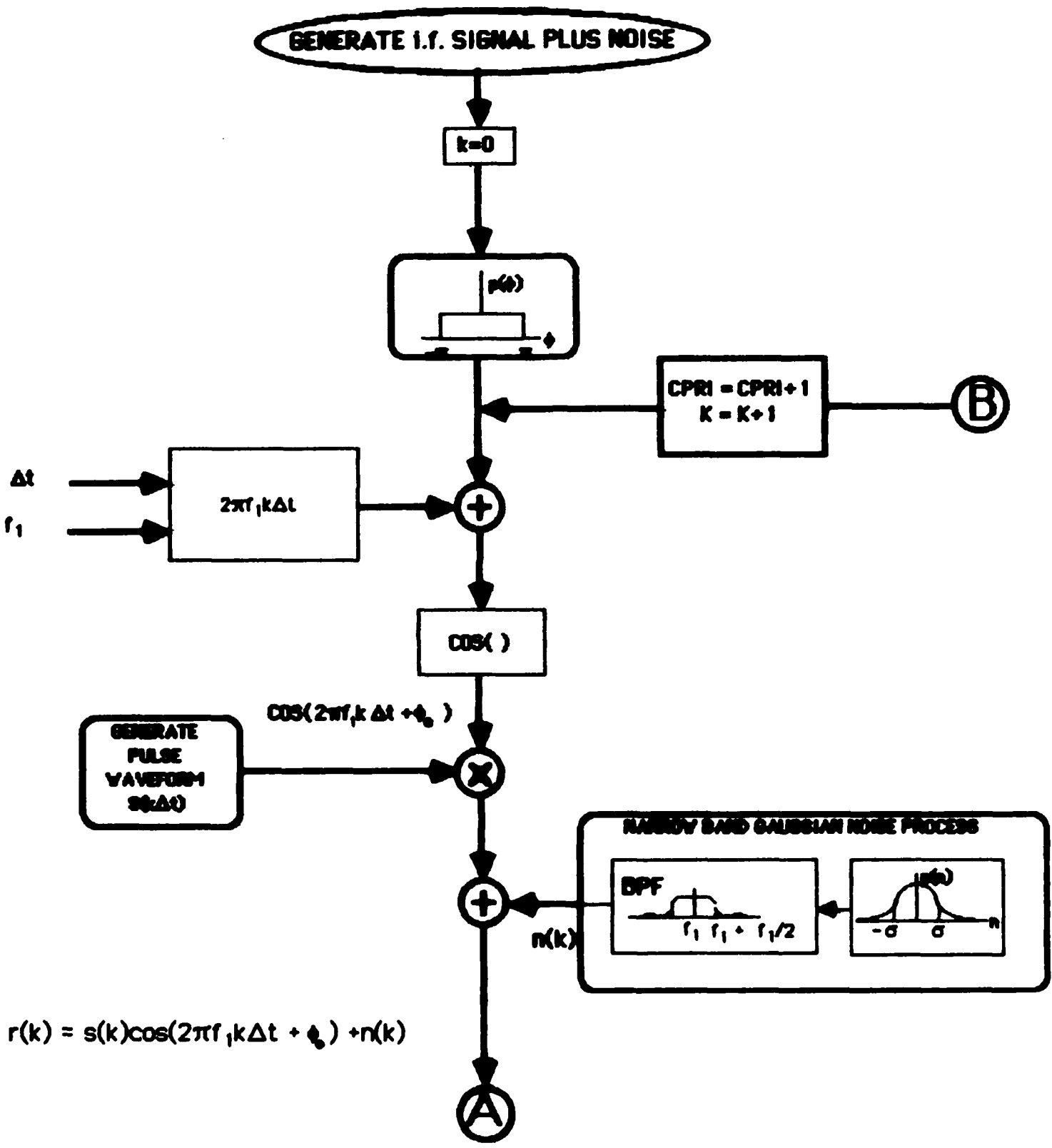

FIGURE 3a: RECEIVER SIMULATION FLOW CHART

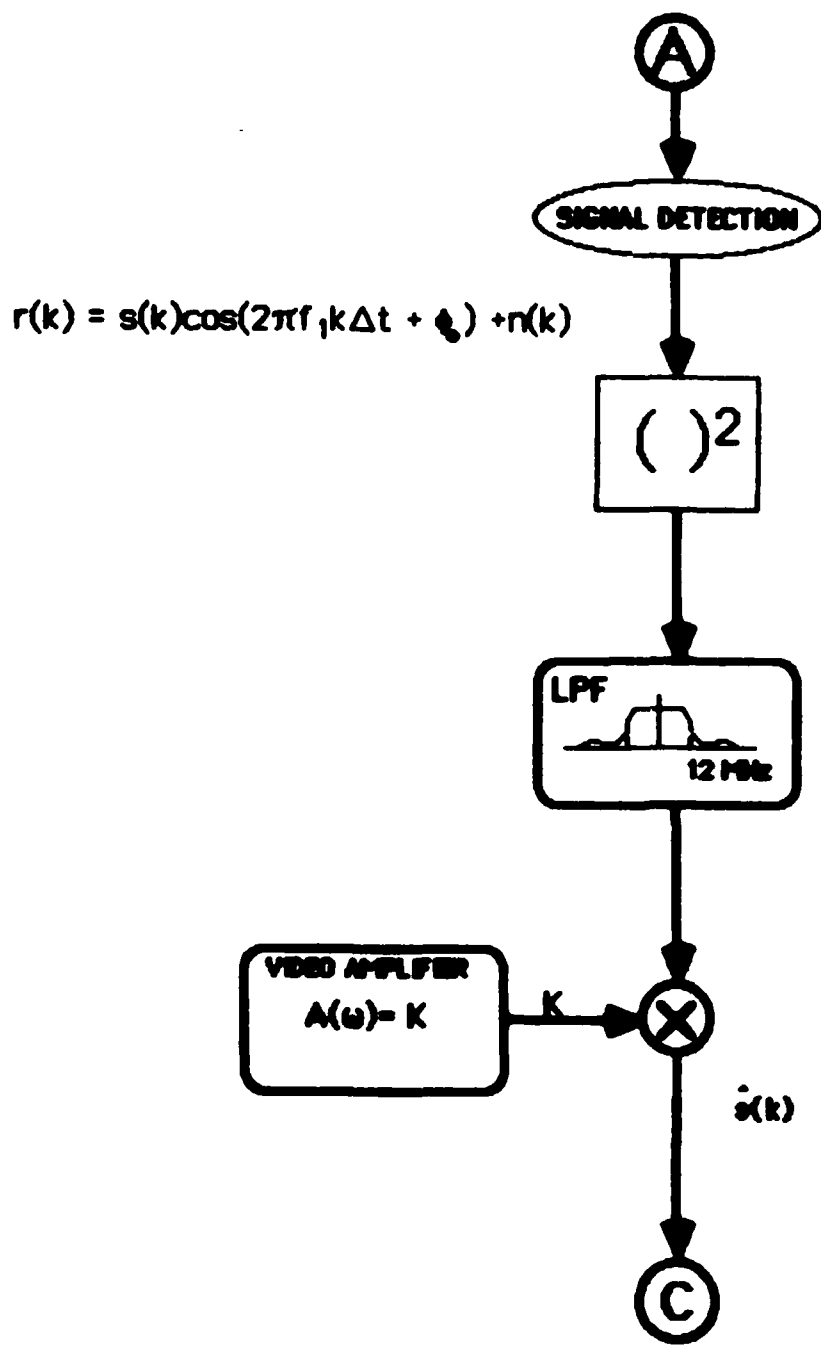

FIGURE 3b: RECEIVER SIMULATION FLOW CHART (CONTINUED)

1 2 3 4 5 6 7 8 9 10 11 12 13 14 15 16 17 18 19 20 21 22 23 24 25 26 27 28 29 30 31 32 33 34 35 36 37 38 39 40 41 42 43 44 45 46 47 48 49 50 51 52 53 54 55 56 57 58 59 60 61 62 63 64 65 66 67 68 69 70 71 72 73 74 75 76 77 78 79 80 81 82 83 84 85 86 87 88 89 90 91 92 93 94 95 96 97 98 99 100

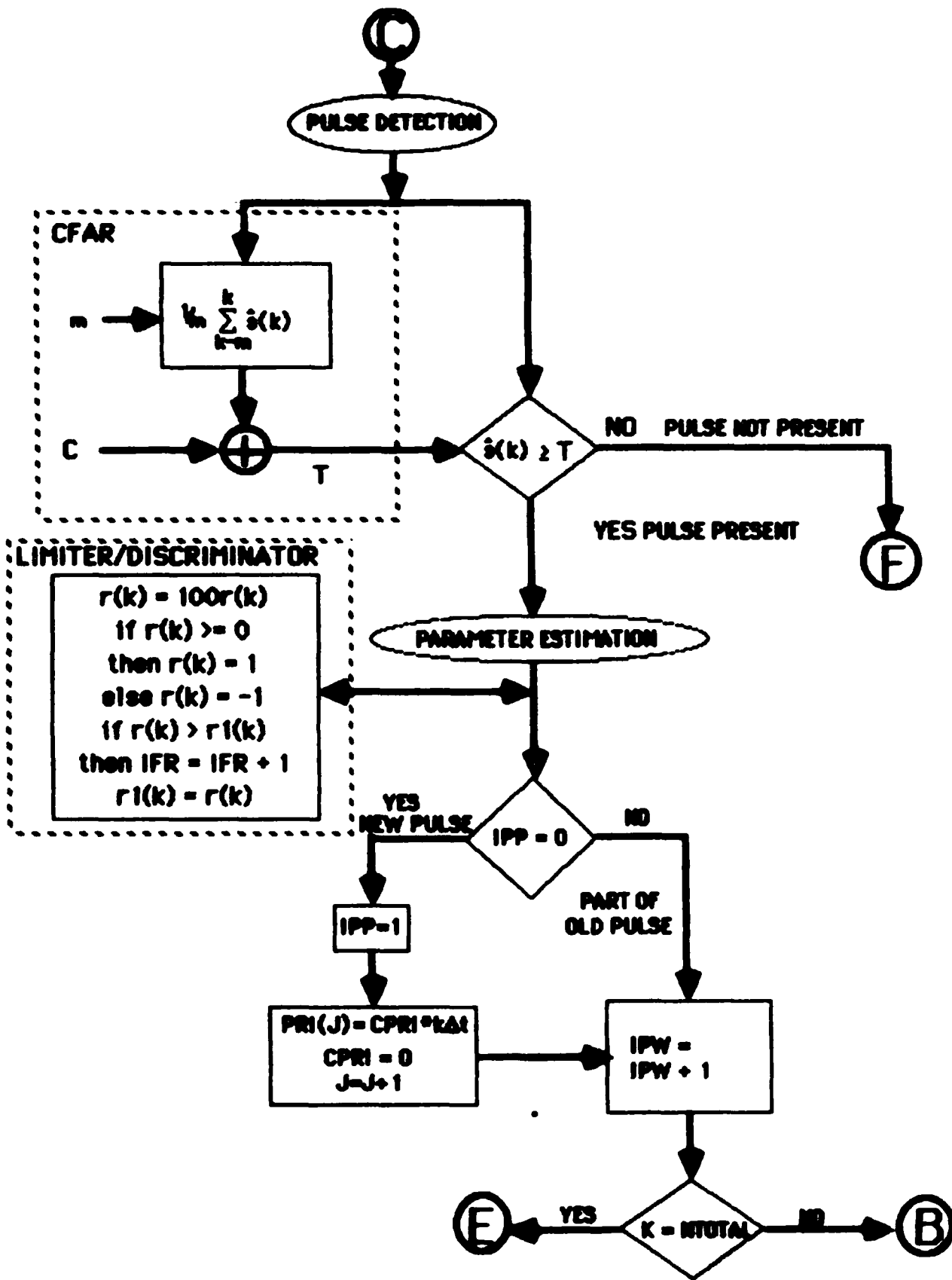

FIGURE 3c: RECEIVER SIMULATION FLOW CHART (CONTINUED)

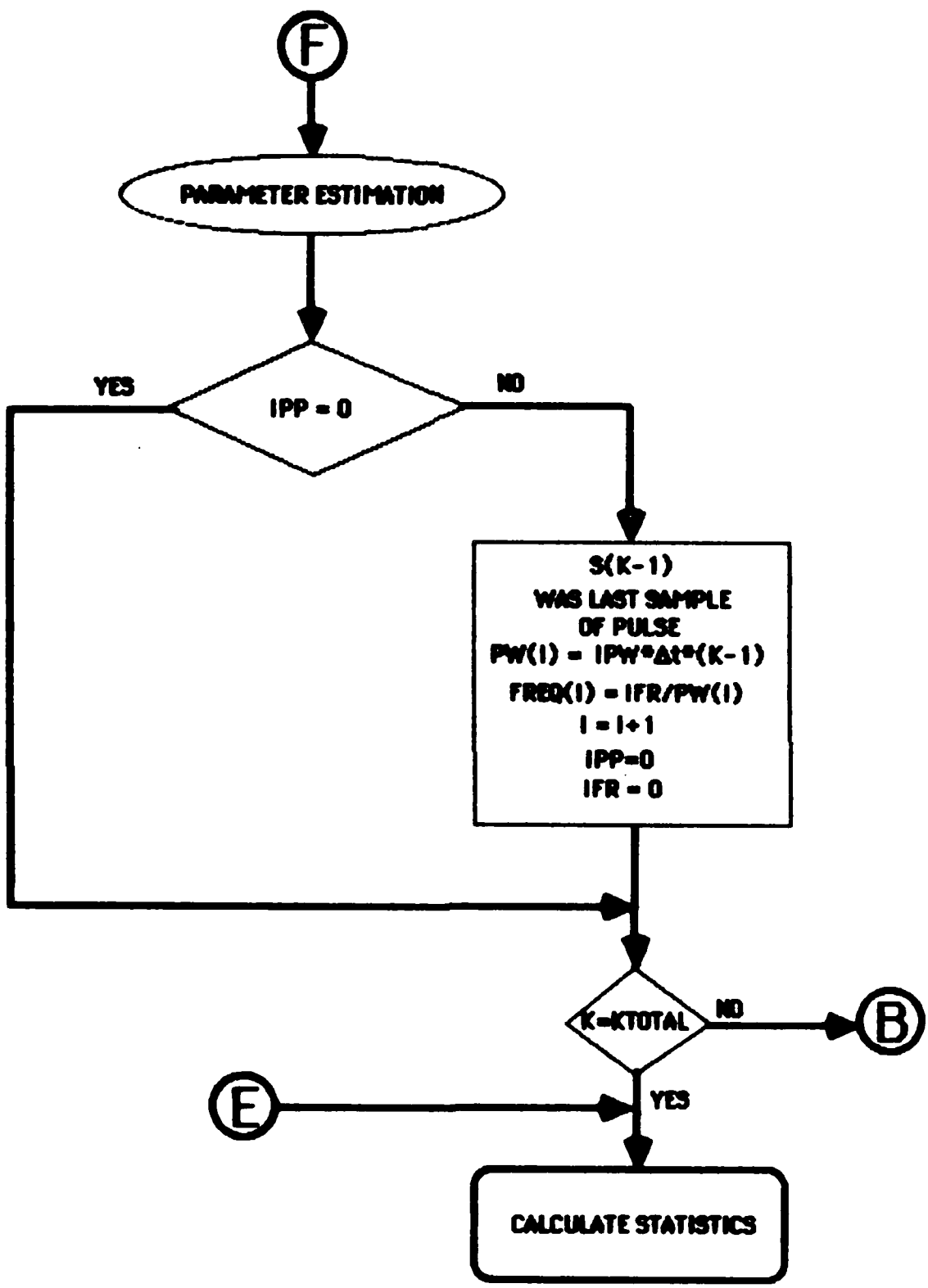

FIGURE 3d: RECEIVER SIMULATION FLOW CHART (CONTINUED)

**ELINT SENSOR PARAMETERIZATION AND DEFINITION
INTERIM REPORT # 1**

4.0 SOURCE CODE LISTING

*****6:34:07 PM 3/29/86*****

*THIS PROGRAM SIMULATES A SIMPLE SUPERHETERODYNE RECEIVER THAT UTILIZES A
* SQUARE LAW DETECTION PROCESS. THE IF OUTPUT SIGNAL IS FIRST GENERATED AS-
* SUMING THAT THE RECEIVED SIGNAL IS A PULSED RADAR SIGNAL OF CONSTANT
* FREQUENCY, RANDOM PHASE, AND CORRUPTED BY AN ADDITIVE GUASSIAN NOISE CHAN-
* NEL.

*
*
* GENERATE THE RECEIVER IF SIGNAL
*
*

- * K -- SAMPLE COUNTER
- * KTOTAL -- TOTAL NUMBER OF SAMPLES TO BE GENERATED
- * SNR -- SPECIFIED SIGNAL-TO-NOISE RATIO OF RECEIVED SIGNAL
- * R(K) -- RECEIVED SIGNAL AT OUTPUT OF I.F. AMPLIFIER
- * F1 -- I.F. FREQUENCY
- * DELT -- THE SAMPLE INTERVAL DELTA T
- * PHI -- RANDOM PHASE OF THE RECEIVED SIGNAL R(K)
- * S(K) -- PULSE ENVELOPE OF RECEIVED SIGNAL
- * PWID -- PULSE WIDTH
- * M -- NUMBER OF CFAR INTEGRATION SAMPLES
- * C -- CFAR CONSTANT
- * G -- VIDEO AMPLIFIER GAIN
- * IPP -- PULSE PRESENT INDICATOR
- * IFR -- DISCRIMINATOR ZERO CROSSING COUNTER
- * CPRI -- PRI SAMPLE COUNT
- * IPW -- PULSE WIDTH SAMPLE COUNT
- * PRI(N) -- MEASURED PULSE INTERVAL OF NTH PULSE
- * PW(N) -- MEASURED PULSE WIDTH OF NTH PULSE
- * FREQ(N) -- MEASURED FREQUENCY OF NTH PULSE

*
*

*DECLARATIONS

*
*

```

INTEGER K, IPP, J, I, IFR, CPRI, IPW, L, O, O1, Q
Integer*4 TICKCOUNT, TICK1, TICK2, toolbox
REAL Y(4200), X(4200), R(4200), PRI(1000), PW(1000), FREQ(1000)
REAL H(32), HL(24), RDET(4200)
PARAMETER (TICKCOUNT=2'97580000') ! toolbox definitions
DATA (H(I), I=1,16)/-.57534121E-02, .99027198E-02, 1.75733545E-02,

```

```

1-.65141192E-02, .13960525E-01, .22951469E-02,
1-.19994067E-01, .71369560E-02,
1-.39657363E-01, .11260114E-01, .66233643E-01,
1-.10497223E-01, .85136133E-01, -.12024993E-00,
1-.29678577E00, .30410917E00/
DATA (HL(I), I=1,12)/0.33740917E-02, 0.14938299E-01,
10.10569630E-01,
10.25415067E-02, -0.15929992E-01, -0.34085343E-01,
1-0.38112177E-01, -0.14629169E-01,
1 0.40089541E-01, 0.11540713E00, 0.13850752E00,
10.23354606E00/

```

```

* PRINT *, PULSE PULSEWIDTH PRI FREQUENCY
* 1 SNR
* PRINT *, PREDETEC
* ITION POSTDETECTION
* OPEN(UNIT=18, FILE = 'RCVDATA')
DO 111 I=17,32
L=33-I
H(I) = H(L)
111 CONTINUE
DO 101 I=13,24
L=25-I
HL(I) = HL(L)
101 CONTINUE
98 WRITE(9,*) ENTER NUMBER OF PULSES, MINIMUM SNR, MAXIMUM SNR
*****INITIALIZE COUNTERS AND FLAGS*****
READ(9,*) O, SNRMIN, SNR
TICK1 = toolbx(TICKCOUNT)
DELT = 2.5E-08
F1 = 10.E06
KTOTAL = 4000
PWID = 20.E-06
97 O1=0
Q=0.
SNSUM = 0.
SNSUM1 = 0.
PM=0.
I1 = 1
99 IPP = 0
IPW = 0
J1 = 1
IFR = 0
PWRSIG = 0.

```

```

PWRNOS = 0.
PRESIG = 0.
PRENOS = 0.
KF=5555
* WRITE(9,*) 'ENTER SAMPLE INTERVAL,I.F. FREQUENCY,NUMBER OF
* 1SAMPLES'
* READ(9,*) DELT,F1,KTOTAL
PI = 3.141593
*GENERATE RANDOM PHASE PHI
SIGMA = 1./SQRT(SNR)
PHI = RAND(0) ! SEED THE RANDOM NUMBER GENERATOR
PHI = (RAND(1) - .5)*2.0*PI
IDELAY = 2000
L = INT(PWID/DELT)
DO 11 K=1,KTOTAL + 130
TN = RAND(1)-.5
XN = SQRT(LOG(1./(TN*TN)))
XN = XN - (2.30753 + .27061*XN)/(1. + .99229*XN + .04481*XN*XN)
XN = XN*SIGMA
IF(TN.LT.0) XN=-XN
*GENERATE PULSED IF SIGNAL
IF (K .LE. IDELAY .OR. K .GE. L + IDELAY) THEN
R(K) = XN
ELSE
R(K) = 1.4142*COS(2*PI*F1*K*DELT + PHI) + XN
END IF
11 CONTINUE
* BANDLIMITED ZERO MEAN WHITE GAUSSIAN NOISE
* BANDPASS NOISE TO +/- F1/2
* FINITE IMPULSE RESPONSE (FIR) LINEAR PHASE BANDPASS DIGITAL FILTER
* -10DB POINTS ARE .14 AND .39 OF THE NYQUIST FREQUENCY
DO 102 K=32,KTOTAL+130
Y(K) = 0.
DO 102 J = 1,32
102 Y(K) = Y(K) + H(J)*R(K-J+1) !BANDPASS LIMITED PULSE I.F. PLUS NOISE
DO 21 K=1,KTOTAL+ 99
Y(K) = Y(K+31)*Y(K+31) !PERFORM SQUARE LAW DETECTION
IF(K.LE.IDELAY-32 .OR. K.GE.IDELAY+L) THEN
PRENOS = PRENOS + Y(K)*Y(K)/(KTOTAL + 67 - L)
ELSE
PRESIG = PRESIG + Y(K)*Y(K)/L
END IF
21 CONTINUE

```

```
PRESNR = PRESIG/PRENOS
PRESNR = PRESNR
PSNRDB = 10*LOG 10(PRESNR)
```

```
*****LOW PASS FILTER DETECTOR OUTPUT*****
```

```
*****-10 DB POINT IS .05 OF THE NYQUIST FREQUENCY*****
```

```
RDET(1) = 0.
DO 202 K=1,100
RDET(1) = RDET(1) + .01*Y(K)
202 CONTINUE
DO 203 K=2,KTOTAL
RDET(K) = RDET(K-1) + .01*(Y(K+99)-Y(K-1))
IF(K.LE.IDELAY-130 OR K.GE.IDELAY+L) THEN
  PWRNOS = PWRNOS + RDET(K)*RDET(K)/(KTOTAL - L-130)
ELSE IF (K.GE.IDELAY-130 AND K.LE.IDELAY+L) THEN
  PWRSIG = PWRSIG + RDET(K)*RDET(K)/(L-130)
END IF
203 CONTINUE
SIGNOS = PWRSIG/PWRNOS
SIGNOS = SIGNOS - 1.0
SIGNOSDB = 10.*LOG 10(SIGNOS)
SNSUM = SNSUM + SIGNOS/O
SNSUM1 = SNSUM1 + PRESNR/O
```

```
*****PARAMETER ESTIMATION*****
```

```
T = SQRT(18.4*PWRNOS)
DO 400 K=1,KTOTAL
IF( RDET(K) .LT. T AND IPP=0 AND K=KTOTAL) GO TO 206
IF( RDET(K) .GE. T AND IPP=0 ) THEN
  KF=K
  T=T/2.          ! FIRST SAMPLE OF NEW PULSE
  IPP=1
  PRI(I1) = (2000. + K)*DELT*1000000.
  IPW = IPW + 1
ELSE IF( RDET(K) .GE. T AND IPP=1 ) THEN
  IPW = IPW + 1
ELSE IF( RDET(K) .LT. T AND IPP=1 ) THEN
  PW(I1) = IPW*DELT*1000000.
  GO TO 401
END IF
400 CONTINUE
401 IF(KF.NE.5555) THEN
  DO 204 K=KF,KF+IPW
  IF(R(K).LT.0) THEN
    R(K) = -1.
```

```

ELSE
  R(K) = 1.
END IF
204 CONTINUE
END IF
DO 205 K=KF,K+IPW
205 IF(R(K).NE.R(K+1)) IFR = IFR + 1
  FREQ(I1) = IFR/PW(I1)/2.
* PRINT 5002 ,I1,PW(I1),PRI(I1),FREQ(I1),PSNRDB, SIGNOSDB
*5002 FORMAT(1X,I4,3X,F10.4,3X,F10.4,8X,F10.4,4X,F10.4,2X,F10.4)
  GO TO 207
206 PM = PM + 1./O
* PRINT 5003, I1,T,SIGNOSDB
*5003 FORMAT(1X,I4,6X,16HMISSSED DETECTION,5X,12HTHRESHOLD = ,F10.4,
* 15X,6HSNR = ,F10.4)
207 I1 = I1 + 1
  O1=O1-1
  IF (O1.GT.O) GO TO 99
  SNSUM = 10*LOG 10(SNSUM)
  SNSUM1 = 10*LOG 10(SNSUM1)
  WRITE(6,*) 'AVERAGE PREDETECTION SNR = ',SNSUM1,'
1AVERAGE POSTDETECTION SNR = ',SNSUM
  PD =(1. - PM)*100.
  WRITE(6,*) 'PROBABILTY OF DETECTION = ',PD,' PER CENT'
  TICK2 = too1bx(TICKCOUNT)
  TIME = FLOAT(TICK2 - TICK1)/60.
  WRITE(6,*) 'ELAPSED TIME = ',TIME,' SECONDS'
  SNR = SNR - .10
  IF(SNR-SNRMIN > 0.) GO TO 97
* DO 91 K=1,KTOTAL
* X(K) = RDET(K)
* Y(K) = 0.0
*91 CONTINUE
* CALL FFT4(X,Y,4096,6)
* NTOTAL = KTOTAL/2
* DO 40 K=1,NTOTAL
* RDET(K) = X(K)*X(K) + Y(K)*Y(K)
* RDET(K) = 10.*LOG 10(RDET(K))
*40 CONTINUE
*****AVERAGE ARRAY *****
* LTOTAL = NTOTAL/4
* DO 50 K=1,LTOTAL
* Y(K) = 0.0

```

```

*50 CONTINUE
*   L=1
*   M=4
*   DO 60 K=1,LTOTAL
*   DO 70 J=L,M
*   Y(K) = Y(K) + RDET(J)/4.
*70 CONTINUE
*   L=L+4
*   M=M+4
*60 CONTINUE
*   WRITE(18,5010) (RDET(K),K=1,NTOTAL)
*5010 FORMAT(2X,F15.4)
*   WRITE(9,*) 'ENTER 1 TO CONTINUE'
*   READ(9,*) Q
*   IF(Q=1) GO TO 98
*   STOP
*   END

```

FUNCTION Rand(IX)

```

*
* This random number generator is a variation on Tausworthe
* generator described in "Solution of Statistical Distribution
* Problems" by H. O. Hartley in Statistical Methods for Digital
* Computers Vol. III, edited by Enstein, Ralston, and Will
* (John Wiley and Sons 1977). The only modification of consequence
* is the ability to reseed the generator with the system tickcount.
*
* The function returns a real value between 0 and 1.
* Rand(0) will reseed the random sequence using system tickcount.
* Rand(1) will use previous calls values as seeds for next number
* in the sequence. Always using Rand(1) will generate a specific
* random sequence based upon starting values internal to
* the function.
*

```

```

Real*4 Factor,Ku1,Ku2
Integer*4 toolbox, BITXOR, TICKCOUNT ! toolbox definitions
Integer*4 KU3,LU1,KC,N2TM,N2TCM
Equivalence (KU2,KU3), (KU1,LU1)
PARAMETER (BITXOR='Z'85992000') ! toolbox definitions
PARAMETER (TICKCOUNT='Z'97580000') ! toolbox definitions

```

```

* Note that the parameter statement assigns a value to
* the indicated constant label. In this case, it is the indey

```

- * into a table of trap addresses contained in TOOLBX.SUB which
- * converts the call to a trap call. A list of these assignments
- * is given in the file TOOLBX.PAR.
- *
- * You must explicitly tell MacFortran to save the values of
- * local variables across successive calls of the subroutines.
- *

SAVE

Data Factor/0.4656613e-9/

Data N2TCM/z'00040000'/

Data KU1,KC,N2TM/z'40000003'z'7ffffff'z'00002000'/

- * KU1 enters with U(1) uniform random variable
- * KU2 leaves with U(1+1) uniform random variable
- * KCU1 complement of KU1
- * KCU2 complement of KU2
- * KC complementing constant
- * LXXX□ logical equivalences of above LXXX
- * N2TM 2**M where M is shift factor
- * n2TCM 2**P-M where P is word size
- * Factor float value of 2**P
- * XOR is the exclusive or operator

```

if (IX=0) KU1=toolbx(TICKCOUNT)
KU1=toolbx(BITXOR,KU1,LU1/N2TM)
KU2=toolbx(BITXOR,KU1,(LU1*N2TCM) .and. KC)
Rand=FLOAT(KU3)*Factor
KU1=KU2
RETURN
END

```

```

C   A COOLEY-TUKEY RADIX-4 DIF FFT PROGRAM
C   COMPLEX INPUT DATA IN ARRAYS X AND Y

```

C

C

C

C

SUBROUTINE FFT4 (X,Y,N,M)

REAL X(1024), Y(1024)

REAL*8 E

-----MAIN FFT LOOPS-----

N2 = N

```

DO 10 K = 1,M
  N1 = N2
  N2 = N2/4
  E = 6.283185307179586/N1
  A = 0
  DO 20 J = 1,N2
    B = A + A
    C = A + B
    CO1 = COS(A)
    CO2 = COS(B)
    CO3 = COS(C)
    SI1 = SIN(A)
    SI2 = SIN(B)
    SI3 = SIN(C)
    A = J*E
    DO 30 I=J, N, N1
      I1 = I + N2
      I2 = I1 + N2
      I3 = I2 + N2
      R1 = X(I) + X(I2)
      R3 = X(I) - X(I2)
      S1 = Y(I) + Y(I2)
      S3 = Y(I) - Y(I2)
      R2 = X(I1) + X(I3)
      R4 = X(I1) - X(I3)
      S2 = Y(I1) + Y(I3)
      S4 = Y(I1) - Y(I3)
      X(I) = R1 + R2
      R2 = R1 - R2
      R1 = R3 - S4
      R3 = R3 + S4
      Y(I) = S1 + S2
      S2 = S1 - S2
      S1 = S3 + R4
      S3 = S3 - R4
      X(I1) = CO1*R3 + SI1*S3
      Y(I1) = CO1*S3 - SI1*R3
      X(I2) = CO2*R2 + SI2*S2
      Y(I2) = CO2*S2 - SI2*R2
      X(I3) = CO3*R1 + SI3*S1
      Y(I3) = CO3*S1 - SI3*R1

```

```

30 CONTINUE
20 CONTINUE

```

10 CONTINUE

C-----DIGIT REVERSE COUNTER-----

```
100 J=1
    N1 = N - 1
    DO 104 I=1, N1
        IF (I.GE.J) GOTO 101
        R1 = X(J)
        X(J) = X(I)
        X(I) = R1
        R1 = Y(J)
        Y(J) = Y(I)
        Y(I) = R1
101 K = N/4
102 IF (K*3.GE.J) GOTO 103
    J = J - K*3
    K = K/4
    GOTO 102
103 J = J + K
104 CONTINUE
    RETURN
    END
```

ELINT SENSOR PARAMETERIZATION AND DEFINITION INTERIM REPORT # 1

5.0 RESULTS AND CONCLUSIONS

The previous pages of this report have documented the development of the Sensor model. In this section model validation and verification will be demonstrated. In order to validate the model a received signal disturbed only by Gaussian noise was assumed and the signal processing was examined at intermediate points within the model to see if the model was behaving as one would expect.

The assumed signal parameters for the validation runs were $F_{IF} = 10$ MHz and a pulsewidths of 10, 20, and 50 μ sec.

A FFT routine was used to observe the output of the IF bandpass filter. The results of two runs of SNRs of 0 db and 10 db (SNR measured at input of IF filter) are depicted in Figure 5.1. As expected the output is a bandpass spectrum centered at 10 MHz with a spectral width of 10 MHz. Next the output of the detector lowpass filter was observed. This is illustrated in Figure 5.2. Again we see what one would hope to. A lowpass spectrum of spectral width of about 5 MHz (adequate to accurately reproduce pulsewidths of 2 μ sec and greater) and the signal energy concentrated at the lower frequencies.

Figures 5.3, 5.4, and 5.5 depict time domain plots of the detector output. The received pulse SNR was 20 db, 13 db, and 3 db respectively in the IF bandwidth. The stronger pulses were detected and the pulsewidth of 50 μ sec correctly measured. At a SNR = 3db false detection occurred and pulsewidth was incorrectly measured. The plots as shown have been smoothed to facilitate the plotting process. This enhances the SNR as seen in the plots and the detector was working at a SNR of about 13db less than one would estimate by looking at the plots alone.

**ELINT SENSOR PARAMETERIZATION AND DEFINITION
INTERIM REPORT # 1**

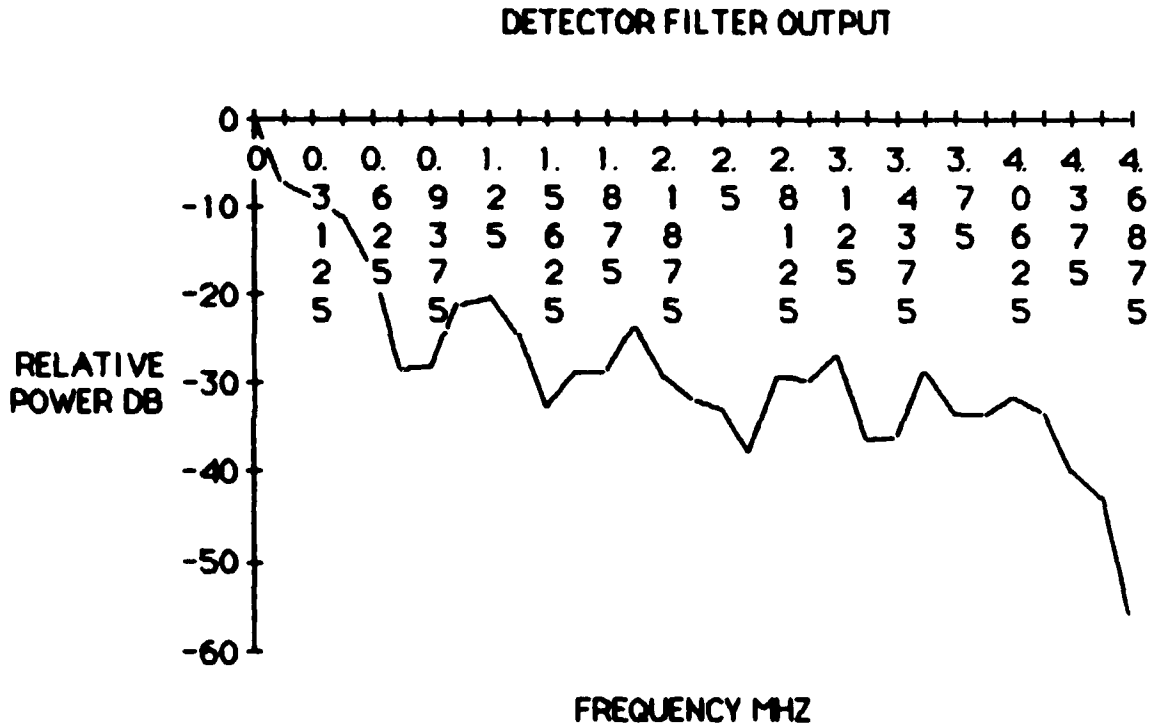

FIGURE 5.2. DETECTOR LOWPASS FILTER SPECTRAL OUTPUT.

ELINT SENSOR PARAMETERIZATION AND DEFINITION INTERIM REPORT # 1

DETECTED PULSE SNR = 20 DB
 PULSE WIDTH = 50 MICROSEC
 MEASURED PULSEWIDTH = 50.225
 MICROSECS

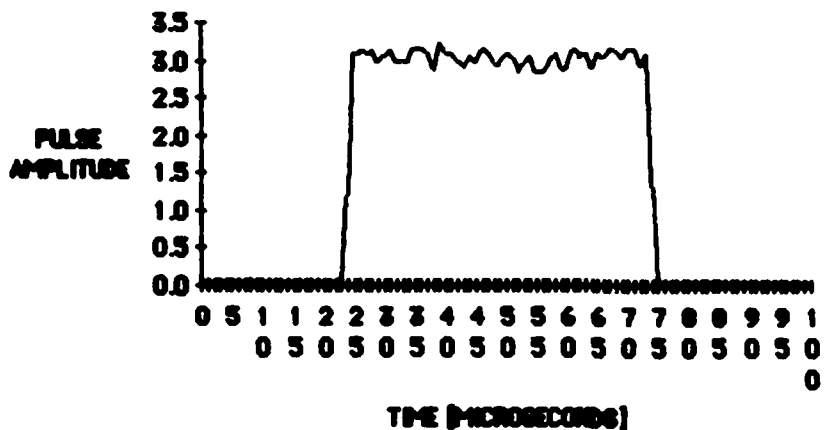

FIGURE 5.3. DETECTED PULSE WITH HIGH SNR

DETECTED PULSE SNR = 13 DB
 PULSEWIDTH = 50 MICROSECONDS
 MEASURED PULSEWIDTH = 50.275
 MICROSECONDS

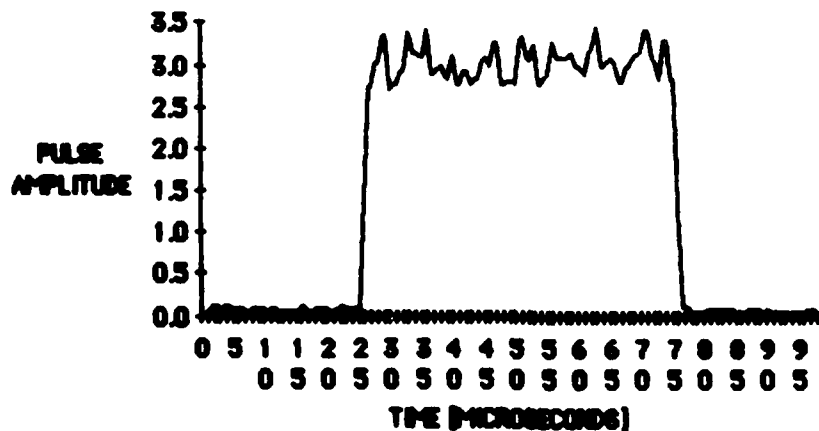

FIGURE 5.4. DETECTED PULSE OF LOWER SNR.

ELINT SENSOR PARAMETERIZATION AND DEFINITION INTERIM REPORT # 1

IMPROPERLY DETECTED PULSE SNR = 3
PULSEWIDTH = 50 MICROSECONDS
MEASURED PULSEWIDTH = .075
MICROSECONDS

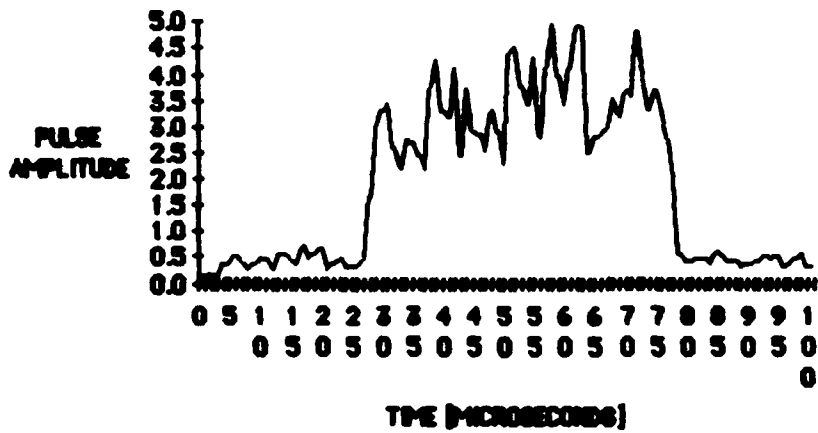

FIGURE 5.5. PULSE OF LOW SNR THAT WAS NOT PROPERLY DETECTED

ELINT SENSOR PARAMETERIZATION AND DEFINITION INTERIM REPORT # 1

The model was exercised many times with received signals of varying SNRs and then the measured probability of detection was compared to theoretical as documented in many standard references*. A plot of SNR vs. Probability of Detection for this model is presented in Figure Eight.

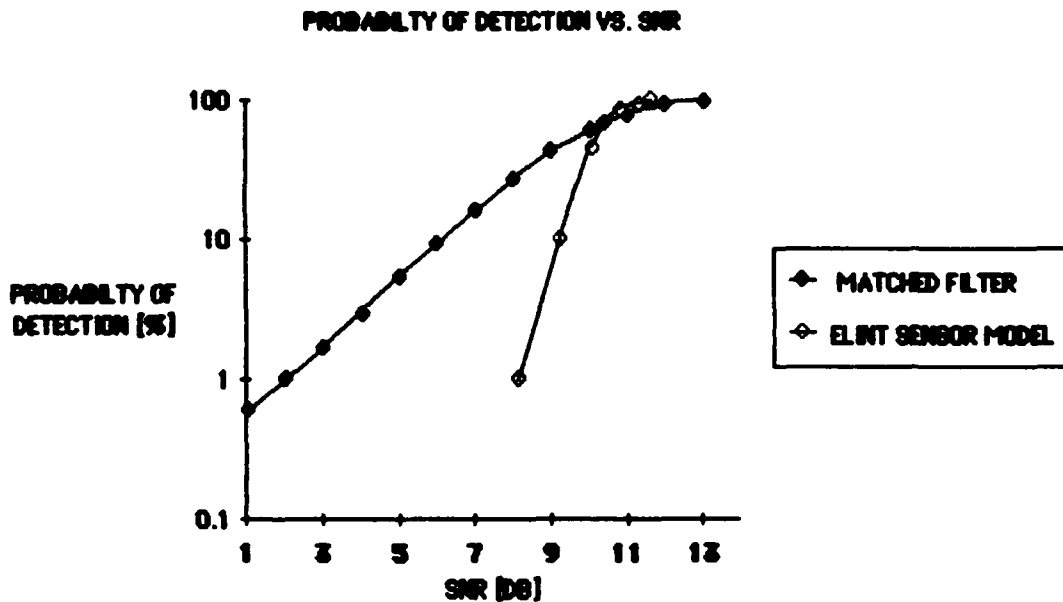

FIGURE 5.6. PROBABILITY OF DETECTION VS. SNR PLOT FOR THE ELINT SENSOR MODEL

As can be seen performance is comparable at high SNRs but degrades rapidly as SNR decreases. This is because the detection process modeled is not matched filter detection and is not optimum at lower SNRs but is instead designed to reproduce a detected pulse with sufficient fidelity to provide good pulse parameter measurement capability.

In conclusion, then, it can be said that the sensor model at its present state of development performs as expected when excited with signals plus Gaussian noise and will provide a tool by which the output distributions of other types of signals may be studied.

* SEE FOR INSTANCE "RADAR TARGET DETECTION HANDBOOK OF THEORY AND PRACTICE" BY MEYER AND MAYER

END

11-87

DTIC