



1-C

1-1

1-25

2-8  
3-15  
3-5  
4-0  
4-5

1-4

2-4

2-2

2-0

1-8

1-6

2

DTIC FILE COPY

AD-A186 306

# NAVAL POSTGRADUATE SCHOOL Monterey, California



## THESIS

A REVIEW OF THE EVOLUTION OF NAVAL DATA  
AUTOMATION AND THE OPTICAL MEDIA  
MASS STORAGE ALTERNATIVES RELATED TO  
NAVAL AVIATION TECHNICAL DOCUMENTATION

by

Robert J. Clarey

September 1987

Thesis Advisor:

Norman R. Lyons

Approved for public release; distribution is unlimited

DTIC  
ELECTE  
NOV 20 1987  
S D  
H

87 11 9 047

UNCLASSIFIED

SECURITY CLASSIFICATION OF THIS PAGE

## REPORT DOCUMENTATION PAGE

1a REPORT SECURITY CLASSIFICATION <b>Unclassified</b>		1b RESTRICTIVE MARKINGS	
2a SECURITY CLASSIFICATION AUTHORITY		3 DISTRIBUTION/AVAILABILITY OF REPORT Approved for public release; Distribution is unlimited	
2b DECLASSIFICATION/DOWNGRADING SCHEDULE		5 MONITORING ORGANIZATION REPORT NUMBER(S)	
4 PERFORMING ORGANIZATION REPORT NUMBER(S)		7a NAME OF MONITORING ORGANIZATION Naval Postgraduate School	
6a NAME OF PERFORMING ORGANIZATION Naval Postgraduate School	6b OFFICE SYMBOL (if applicable) Code 54	7b ADDRESS (City, State, and ZIP Code) Monterey, California 93943-5000	
6c ADDRESS (City, State, and ZIP Code) Monterey, California 93943-5000		9 PROCUREMENT INSTRUMENT IDENTIFICATION NUMBER	
8a NAME OF FUNDING/SPONSORING ORGANIZATION	8b OFFICE SYMBOL (if applicable)	10 SOURCE OF FUNDING NUMBERS	
8c ADDRESS (City, State, and ZIP Code)		PROGRAM ELEMENT NO	PROJECT NO
		TASK NO	WORK UNIT ACCESSION NO
11 TITLE (include Security Classification) A REVIEW OF THE EVOLUTION OF NAVAL DATA AUTOMATION AND THE OPTICAL MEDIA MASS STORAGE ALTERNATIVES RELATED TO NAVAL AVIATION TECHNICAL DOCUMENTATION (u)			
12 PERSONAL AUTHOR(S) Clarey, Robert J.			
13a TYPE OF REPORT Master's Thesis	13b TIME COVERED FROM _____ TO _____	14 DATE OF REPORT (Year Month Day) 1987 September	15 PAGE COUNT 141
16 SUPPLEMENTARY NOTATION			
17 COSATI CODES		18 SUBJECT TERMS (Continue on reverse if necessary and identify by block number)	
FIELD	GROUP	Naval Data Automation, Optical Media Technology, Naval Aviation Maintenance Documentation, CD-ROM Publishing	
19 ABSTRACT (Continue on reverse if necessary and identify by block number) The increased sophistication and complexity of new weapon systems have generated an exponential growth in the associated technical support documentation. This 'data explosion' impacts several data management issues including: the exorbitant costs associated with the initial development and distribution of this required information; the massive weight, environmental and space considerations attributable to the storage of this data; and the complex task of publishing and distributing revisions to previously disseminated documentation. This research serves as a preliminary feasibility study, analyzing the optical media storage and presentation alternatives applicable to Naval Aviation technical manual publication and distribution methodologies. The research includes a synopsis of the DOD/DON directives and programs aimed at data automation and digitization processes with particular emphasis on the Naval Aviation environment. This thesis concludes with the recommendation to continue investigation of the optical mass storage alternatives. Furthermore, this study recommends research emphasis of the CD-ROM format due to its standardization lead, technological maturation, economy to scale advantages resulting from the audio compact disc success and the environmental and transportable benefits associated with this medium.			
20 DISTRIBUTION/AVAILABILITY OF ABSTRACT <input checked="" type="checkbox"/> UNCLASSIFIED/UNLIMITED <input type="checkbox"/> SAME AS RPT <input type="checkbox"/> DTIC USERS		21 ABSTRACT SECURITY CLASSIFICATION <b>Unclassified</b>	
22a NAME OF RESPONSIBLE INDIVIDUAL Prof. Norman R. Lyons		22b TELEPHONE (include Area Code) (408) 646-2666	22c OFFICE SYMBOL Code 54Lb

DD FORM 1473, 84 MAR

83 APR edition may be used until exhausted

SECURITY CLASSIFICATION OF THIS PAGE

All other editions are obsolete

UNCLASSIFIED

A-1



Approved for public release; distribution is unlimited.

**A Review of the Evolution of Naval Data Automation  
and the Optical Media Mass Storage Alternatives  
Related to Naval Aviation Technical Documentation**

by

**Robert J. Clarey**  
Lieutenant Commander, United States Navy  
B.S., United States Naval Academy, 1973

Submitted in partial fulfillment of the  
requirements for the degree of

**MASTER OF SCIENCE IN INFORMATION SYSTEMS**

from the

**NAVAL POSTGRADUATE SCHOOL**  
September 1987

Author:



Robert J. Clarey

Approved by:

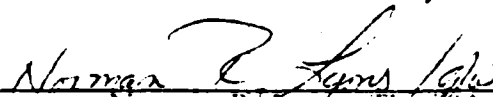

Norman R. Lyons, Thesis Advisor



Lewis G. Mason, Second Reader



Willis R. Greer, Jr., Chairman,  
Department of Administrative Sciences

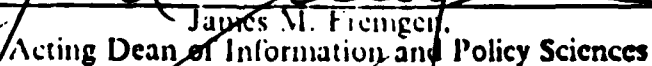

James M. Fremgen,  
Acting Dean of Information and Policy Sciences

## ABSTRACT

The increased sophistication and complexity of new weapon systems have generated an exponential growth in the associated technical support documentation. This 'data explosion' impacts several data management issues including: the exorbitant costs associated with the initial development and distribution of this required information; the massive weight, environmental and space considerations attributable to the storage of this data; and the complex task of publishing and distributing revisions to previously disseminated documentation.

This research serves as a preliminary feasibility study, analyzing the optical media storage and presentation alternatives applicable to Naval Aviation technical manual publication and distribution methodologies. The research includes a synopsis of the DOD/DON directives and programs aimed at data automation and digitization processes with particular emphasis on the Naval Aviation environment.

This thesis concludes with the recommendation to continue investigation of the optical mass storage alternatives. Furthermore, this study recommends research emphasis of the CD-ROM format due to its standardization lead, technological maturation, economy to scale advantages resulting from the audio compact disc success and the environmental and transportable benefits associated with this medium.

## TABLE OF CONTENTS

I.	INTRODUCTION .....	10
A.	A FUTURE SHIPBOARD SCENARIO .....	10
B.	PRELIMINARY THESIS PURPOSE AND SCOPE .....	11
C.	THESIS CHAPTER OUTLINE .....	12
II.	BACKGROUND AND OBJECTIVES .....	14
A.	DATA EXPLOSION PHENOMENON .....	14
B.	THE PAPERLESS SHIP CONCEPT .....	16
C.	DOD DATA DELIVERY AND PRESENTATION DIRECTIVES .....	17
D.	NAVAL AVIATION TECHNICAL MANUAL EMPHASIS .....	18
E.	THESIS TOPIC DECISION .....	18
F.	OBJECTIVE .....	19
G.	RESEARCH QUESTIONS .....	19
H.	METHOD OF STUDY .....	20
I.	SCOPE AND LIMITATIONS .....	21
J.	EXECUTIVE SUMMARY .....	21
III.	EVOLUTION OF DOD/DON DATA AUTOMATION DIRECTIVES .....	23
A.	COMPUTER-AIDED ACQUISITION AND LOGISTIC SUPPORT (CALIS) INITIATIVE .....	23
B.	THE NAVY TECHNICAL INFORMATION PRESENTATION SYSTEM (NTIPS) .....	26
IV.	EVOLUTION OF NAVAL AVIATION TECHNICAL MANUAL DATA AUTOMATION .....	30
A.	AUTOMATED DATA SYSTEM BACKGROUND .....	30
B.	MAINTENANCE INFORMATION AUTOMATED RETRIEVAL SYSTEM (MIARS) .....	33

C.	NAVAL AVIATION LOGISTIC COMMAND MANAGEMENT INFORMATION SYSTEM (NALCOMIS) OVERVIEW .....	35
D.	NAVAL FLIGHT RECORD SYSTEM (NAVFLIRS) .....	38
E.	NAVAL AVIATION DATA AUTOMATION SUMMARY .....	39
V.	OPTICAL MASS STORAGE OVERVIEW .....	41
A.	OPTICAL MASS STORAGE INTRODUCTION .....	41
B.	OPTICAL MEDIA HISTORICAL BACKGROUND .....	46
C.	TECHNOLOGY REVIEW - 'NUTS AND BOLTS' PRESENTATION .....	49
1.	Read-Only Media .....	49
2.	Write-Once/Read-Many (WORM) .....	51
3.	Eraseable Formats .....	53
D.	ADVANTAGES/DISADVANTAGES OF OPTICAL MEDIA .....	58
E.	COMPARISON OF OPTICAL AND MAGNETIC TECHNOLOGIES .....	62
F.	OPTICAL MEDIA PUBLICATION METHODOLOGIES .....	66
VI.	THE CD-ROM BOEING 757 AIRCRAFT MAINTENANCE MANUAL .....	72
A.	BOEING 757 CD-ROM BACKGROUND .....	72
B.	DEVELOPMENT ISSUES .....	75
VII.	CONCLUSIONS AND RECOMMENDATIONS .....	76
A.	OPTICAL MEDIA RECOMMENDATIONS .....	76
B.	OPTICAL SCANNING CONVERSION ISSUES .....	80
C.	RASTER VS VECTOR IMAGING RECOMMENDATIONS .....	82
D.	NAVAL AVIATION TECHNICAL DOCUMENTATION PROJECTIONS .....	83
APPENDIX A:	SCANNER VS. DATA RECONSTRUCTION COST COMPARISON .....	87
APPENDIX B:	RASTER SCAN CONVERSION TO VECTOR REPRESENTATION .....	97

<b>APPENDIX C: COST ANALYSIS OF TYPICAL AVIATION SQUADRON'S INITIAL OPTICAL HARDWARE AND SOFTWARE OUTFITTING AND DISTRIBUTION SAVINGS. ....</b>	<b>106</b>
<b>APPENDIX D: EXAMPLE WORKSTATION SCREENDUMP PRINT-OUTS OF BOEING 757 CD-ROM MAINTENANCE MANUAL .....</b>	<b>111</b>
<b>LIST OF REFERENCES .....</b>	<b>133</b>
<b>BIBLIOGRAPHY .....</b>	<b>136</b>
<b>INITIAL DISTRIBUTION LIST .....</b>	<b>139</b>

## LIST OF TABLES

1. NAVAL AVIATION TECHNICAL MANUAL GROWTH .....	15
2. CD-ROM DISC AND WORM DISK CHARACTERISTICS .....	56
3. CD-ROM AND WORM (5.25" DISK) CAPACITY COMPARATIVE EQUIVALENTS .....	57
4. CD-ROM STORAGE MEDIUM ADVANTAGES .....	59
5. CD-ROM STORAGE MEDIUM DISADVANTAGES .....	60
6. WORM STORAGE MEDIUM ADVANTAGES AND DISADVANTAGES .....	61
7. OPTICAL VS MAGNETIC STORAGE DEVICE COMPARISON .....	65

## LIST OF FIGURES

5.1	CD-ROM Space Utilization--20 Volume Encyclopedia .....	43
5.2	Weight of 540MB In Various Media Formats .....	70
5.3	Equivalent Mailing Costs of 540MB Utilizing Different Media Formats .....	71
6.1	Estimated Automated Data Retrieval Savings Over Printed Documentation .....	74
A.1	Experimental CDP Scanning Test Run Results .....	87

## ACKNOWLEDGEMENTS

There are numerous individuals who contributed to this research and I would like to take this time and space to express my gratitude for their support and contributions:

- \* Professor Norman Lyons--my thesis advisor--for his patience and professional guidance
- \* Cdr. Lew Mason--my second reader--for his insights and proof reading
- \* Lcdr. Barry Frew--for his optical technology expertise and research verifications
- \* Lcdr. Dave Lind--for his research (thesis) package and graphic files
- \* Lt. Steve Frink--for his unselfish assistance in any and every subject area pertaining to this degree
- \* Naval Air Technical Services Facility--my sponsor--in particular Jerry Gruden for his personal efforts on my TAD trip and Steve Markowitz, Don McPeak, and Roger Blackwell of the Policy and Plans Division
- \* Diane Squire--director of sales; PDSC--for the numerous hours involved in explaining CD-ROM disc preparation and software retrieval demonstrations
- \* Don Bissell and Glenn Bergmann--Sundstrand Corporation--for their practical demonstration of the Boeing / British Airways CD-ROM workstation (ADMS) and associated literature and laser printouts
- \* Athol Fodon and Jim Tillinghast--Palantir Corporation--for their analysis, demonstration and literature on the scanner digitization processes
- \* Joe Fuller--DTNSRD--for his NTIPS briefing and related literature
- \* \*\*\* AND MOST IMPORTANTLY \*\*\*, my wife Kathy--whom while defending the country serving as a Navy Nurse in San Diego, had to endure (or maybe enjoy) a twenty month separation preceded by a three year sea duty tour--i most certainly appreciate your patience and sacrifices.--I do MTA!!

## I. INTRODUCTION

### A. A FUTURE SHIPBOARD SCENARIO

The Airboss is hot. A two cycle launch and recovery evolution was disrupted due to a fouled deck. The final F-14 aircraft of the first stage recovery cycle made a low approach, grazed the ramp, barely caught the number four wire and skidded to a screeching halt on the aircrafts' belly after shearing the entire under-carriage, missile racks and drop tanks. Miraculously, there were no personnel injuries, however, due to flying debris and foreign object damage (FOD) to multiple aircraft spotted on the carrier flight deck, flight operations were cancelled until a complete carrier air wing aircraft status report is completed.

The maintenance controls of the four squadrons accountable for the seven total damaged aircraft, assign one technician per aircraft to assess the damage. Each technician takes his personal, portable aircraft status analyzer computer to the aircraft and plugs a cable from the computer to a receptacle in the aircraft that automatically 'reads' the serial numbers, flight hours flown and status, performance data on every component in the aircraft to a floppy diskette residing in the portable computer. Additionally, the technician dictates visual damage and similar pertinent information into a recorder attached to the portable computer. This verbal information may include examples such as tire damage, airframe or skin damage and the location of this damage. The technician returns to maintenance control and transfers his diskette into the maintenance control's server computer that links the maintenance and supply department's local area network. The main computer determines the aircraft's status, automatically assigns workloads to the appropriate workcenters, completes the required supply transactions and determines where the needed replacement parts are located. If the parts are not on the carrier, an immediate dispatch is telecommunicated to the closest re-supply ship or to the appropriate supply depot. Within a half hour, the CAG (Airgroup Commander) has a detailed report listing wing aircraft status and damaged aircraft maintenance requirements.

If, as in this scenario, the maintenance actions run the gamut from a minor airframe hole patch to a complete wing replacement, there exists the possibility that the available technicians have not performed the required maintenance repairs previously.

To accommodate this dilemma, each maintenance control has at its disposal a computer generated, multi-media display system consisting of an audio-visual and elegantly indexed text presentation. This interactive automated technical documentation system describes every possible maintenance action including an on-line, real time video simulation with audio explanations of the required: maintenance procedures, technical level of expertise, tools and support equipment and quality assurance involvement.

The Airboss is not happy because of the situation, but at least he can continue with the second stage of the planned launch and recovery cycle within one hour of the mishap. The damaged aircraft are below deck in the hangar with five of the seven aircraft expected to be in an up status within 12 hours, and the remaining two expected to be up in 48 hours depending on parts delivery.

## **B. PRELIMINARY THESIS PURPOSE AND SCOPE**

Although this previous scenario may sound somewhat dramatic and perhaps even far-fetched, the specific automated data processing((ADP) applications depicted in this dialogue including: automated supply transactions, flight hour accountability, on-board component status systems and an automated or computer generated Navy technical manual presentation system are presently in the implementation or research and development stages. These programs include the Shipboard Non-tactical ADP Program (SNAP) series project, Naval Flight Record System (NAVFLIRS), Naval Aviation Logistics Command Management Information System (NALCOMIS) prerogatives, the F/A-18 on-board engine and avionics systems analyzers and the Navy Technical Information Presentation System (NTIPS). In fact, Mr. Joe Fuller of the David W. Taylor Naval Ship Research and Development Lab in conjunction with the Naval Air Systems Command, is developing a prototype NTIPS application study with an F-14 squadron at NAS Miramar, Ca. The prototype consists of a 'hangar-deck workstation' which includes a standard micro computer, monitor (CRT), laser printer and a commercially developed software package that retrieves and presents on-line troubleshooting, corrective-maintenance and logistic supply (transaction coding and part number verification) information. The operational 'field' test portion of this first stage evaluation produced promising results and will be discussed in greater detail later in this research paper.

The purpose of this thesis is to investigate the feasibility of implementing a large scale automated data publication and distribution application similar to this prototype.

The research methodology will include a review of the evolution of Naval Aviation technical manuals from the paper copy era to the possible future digitization alternatives presently in the research and development stages. This data transformation and automation effort will be analyzed with particular emphasis on: the DOD/DON directives relating to this issue, the more significant programs implemented by the Navy concerned with Naval Aviation technical documentation and the mass storage implications and media alternatives associated with this topic. The mass storage media option analysis will accentuate the optical/laser technologies, examining and comparing the advantages and disadvantages of: cost, environmental concerns, updating considerations and revision accountability. Consequently, due to the enormous applications and breadth of such an analysis, this thesis will serve as a preliminary feasibility study. This "go/no-go" determination will conclude with a recommendation for continuance to a formal feasibility study.

### **C. THESIS CHAPTER OUTLINE**

The following paragraphs briefly summarize the organization and contents of the remaining chapters included in this research paper.

Chapter II provides an in-depth background of the Navy's technical documentation problems, introduces the DOD's initiatives on data conversion from paper to a digital representation and advances the Navy's concept and goal of the 'paperless' ship. This chapter includes thesis topic decision criteria, a more formalized scope and objective statement and specific research questions that will be investigated. The methodologies and limitations encountered in answering these questions are also presented.

Chapter III reviews general DOD/DON data automation directives, while Chapter IV details the evolution of Naval Aviation technical manual development. This chapter analyzes several Naval Aviation programs implemented during various stages of the technical documentation automation progression.

Chapter V offers an overview of the optical/laser technologies. A brief historical review and technical treatment of the three options and the varied media formats within each category is presented. The advantages vs disadvantages of each medium and format, particularly those related to the large-scale publication and distribution environment, are compared. The optical media format standardization issues are discussed. This chapter additionally assesses the specific DOD military applications and the on-going research projects investigating these applications.

Chapter VI will review the development process of an actual on-line CD-ROM aviation technical manual application developed for the British Airways' Boeing 757 aircraft. The discussion will include the indexing and technical illustration representation problems and those issues that would effect the Naval Aviation technical manual automation process. A review of the future technology advancements, such as the interactive CD-ROM (CD-I or DVI) concepts which combine the text, video and audio benefits onto one disc, will be briefly analyzed for future applications.

Chapter VII will summarize the research effort, establish conclusions and make recommendations as to the most suitable alternative analyzed.

## II. BACKGROUND AND OBJECTIVES

### A. DATA EXPLOSION PHENOMENON

The penalty or trade-off to implementing the automated data processing systems described in section A and B of Chapter I is an aggregation of data that just could not be accommodated by present day technologies given the limited resources and physical constraints imposed by the Navy's operating environment. Even before these data intensive 'advanced' interactive and multi-media ADP support systems are fully implemented, the administrative burdens associated with present technical support data are becoming unmanageable. The increased technology and sophistication of new weapons systems have generated support documentation requirements which are increasing at an explosive rate. This necessity for extensive technical support documentation coupled with the ever increasing administrative and tactical support data requirements have created a data management crisis that is reaching a critical juncture in the DOD.

This exponentially increasing data storage requirement has a significant impact on several factors that intensify this data management crisis. These factors include: the exorbitant costs associated with the initial development and distribution of this required information; the massive weight, environmental and space considerations attributable to the storage of this data; and the complex task of publishing and distributing revisions to previously disseminated documentation. In addition to the excessive costs and handling delays related to the extensive publication revision processes, the technical manual updating accountability (particularly in the Navy's diverse, dynamic and global environment), is an administrative nightmare which all too often is not effectively managed. This inability to effectively follow up on and ensure incorporation of technical documentation revisions, presents a severe safety hazard when identified improper or outdated maintenance procedures continue to be performed.

This 'data explosion' predicament, a major problem effecting all Naval activities, is degrading mission readiness and overall DOD performance. To illustrate this problem of exponentially increasing technical support documentation within the Naval Aviation community, an example of the historical technical manual growth by aircraft is depicted in Table 1.

TABLE I  
 NAVAL AVIATION TECHNICAL MANUAL GROWTH

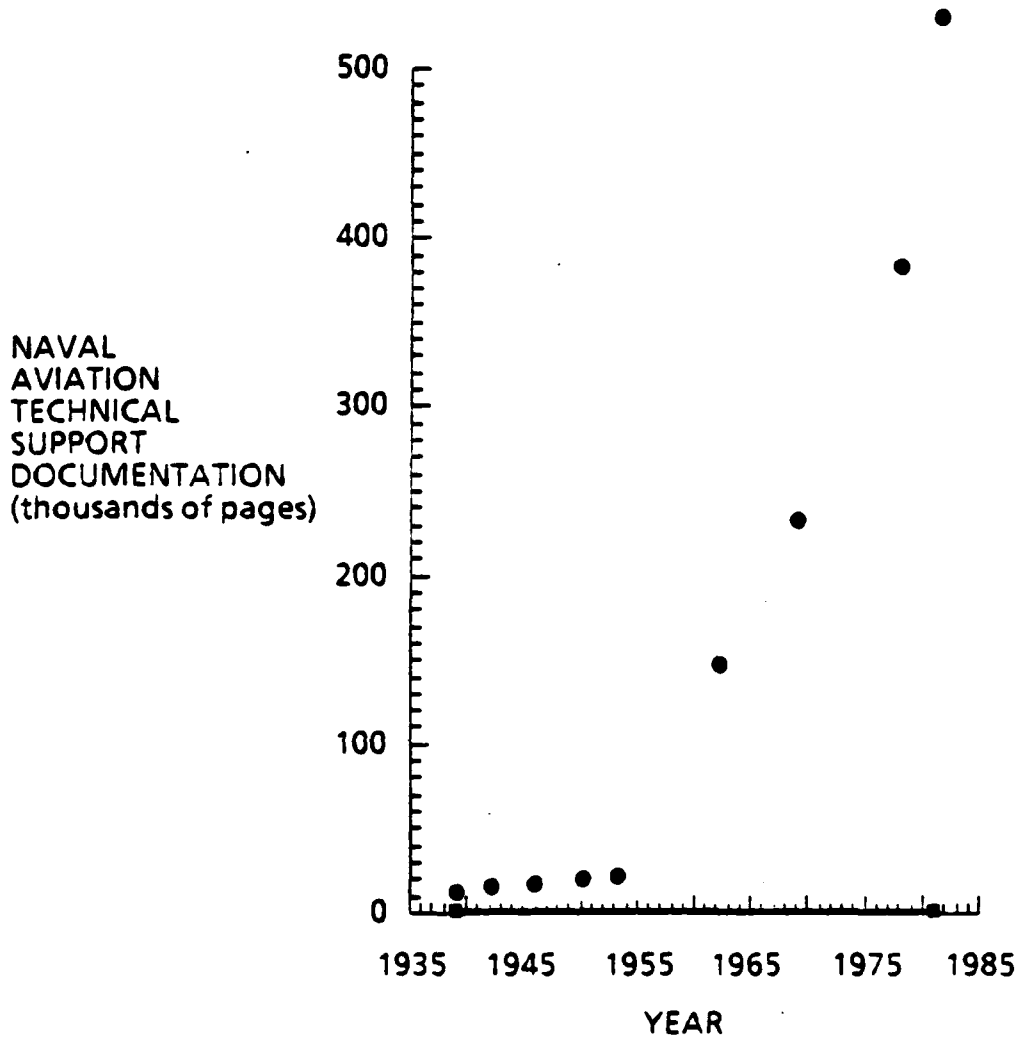

<u>YEAR</u>	<u>AIRCRAFT DESIG</u>	<u>AIRCRAFT CALL</u>	<u>TECH. MANUAL</u>
1939	J-F	GOOSE	525 PAGES
1942	F-6F	HELLCAT	950 PAGES
1946	F-8F	BEARCAT	1,180 PAGES
1950	F-9F	COUGAR	1,880 PAGES
1953	S-2	TRACKER	12,500 PAGES
1962	A-6A	INTRUDER	150,000 PAGES
1969	F-4	PHANTOM	225,000 PAGES
1978	F-14	TOMCAT	380,000 PAGES
1981	F/A-18	HORNET	> 500,000 PAGES

## **B. THE PAPERLESS SHIP CONCEPT**

A major point of the simulation of the original carrier flight deck scenario presented in section A of Chapter I, is the 'paperless' transactions that transpire at every stage of the maintenance evolutions described. The Navy, whose operational constraints relating to weight, space and environmental conditions are more critical, has long since recognized the need to solve the paperwork storage explosion problem.

A product of the research effort invested in trying to solve this 'paperwork' or data explosion problem was the innovative and daring concept of the U.S. Navy 'paperless' ship. The goal of the 'paperless' ship has strong support from the Navy's highest level as directed by the CNO in a memo of DEC 1986 [Ref. 1]. This directive confirms the fact that this goal is not just a long term pipe dream but a commitment to accomplish this objective by 1990. Spearheading this 'movement' to reduce this paperwork storage requirement is Vice Admiral Joseph Metcalf, Deputy CNO for Surface Warfare. In an AP wire service article titled "Damn the Paper Work, Full Speed Ahead", Admiral Metcalf suggests:

When one of the Navy's newest frigates leaves port it carries Standard air-defense missiles, Harpoon anti-ship missiles, MK-46 torpedoes - and lots of paper.

So much paper that if you add in the file cabinets needed to hold it all it comes to 41,000 pounds--20 tons . . . "We do not shoot paper at the enemy". Most of it represents thousands and thousands of pages in technical manuals, considered essential to sailors who must maintain or repair the sophisticated weaponry and propulsion systems that make a modern warship potent. "We don't train sailors to be registrars and correctors of publications . . . that's dumb" . . . Navy ships already have small personal computers on board and the Navy also is now exploring off-the-shelf items in use by industry such as "laser cards" and magnetic or optical discs. [Ref. 2]

Echoing this call for a reduction in paperwork storage, Rear Admiral Harry S. Quast, Director for Navy Information Systems, foresees the need for a system similar to that described in the carrier scenario of section A of Chapter I.

Gone will be the libraries of maintenance manuals, instruction books and operations data weighing several tons and filling hundreds of storage shelves in the sea service's 600 ships . . . Gone, too, may be lesson plans for classes, laundry lists, cooks' menus and even their recipes. Pens and pencils could become archaic . . . in their place--more fitting for the Star Wars age--will be compact discs, portable laser machines and other computer generated images the ships' crew will need to perform the day-to-day work and maintenance on their vessels.

Instead of carrying a maintenance book into the bilges of a ship to repair a pump, tomorrow's sailor may well carry a small computer terminal in his toolbox. [Ref. 3: p. D1]

The Navy is of course not the only DOD agency dealing with this paperwork storage problem. In fact, a precursor to the Navy's proclivity towards a 'paperless' agency, was the DOD's efforts to establish a policy on data conversion from the existing paper-intensive documentation support process to an electronic and automated digitized data format. It should be obvious that the transition from the paper based media to digital based storage alternatives is no short term or easy evolution. The DOD and more specifically the individual services, have to acknowledge the long term ramifications of disjointed data digitization methodologies. It is imperative that the DOD and the individual services ratify a policy on data standardization issues early on in this process and yet remain flexible enough to accommodate the considerable technological breakthroughs occurring frequently in the ADP environment.

### **C. DOD DATA DELIVERY AND PRESENTATION DIRECTIVES**

As a result of the concern over the vast amounts of paperwork associated with new weapons systems, a DOD initiated study was established to preclude the Defense Department's (or for that matter the entire Federal Government's) repeated occurrences of inter-service, non-standardized acquisition of support documentation related to both hardware and software information environments. The DOD has been researching this data transportability problem for several years and this study culminated with the formulation of a joint agency agreement on digital data standardization. The release of the DOD CALS (Department of Defense Computer-aided Acquisition and Logistic Support) draft in March of 1987 [Ref. 4], which included MIL-STD-1840A also of March 1987 [Ref. 5], directed that current and future DOD documentation will be in a digitized format. This joint services initiative was a major DOD commitment that heralded in a new era of data presentation and storage. Although this directive is a major milestone in the implementation of electronic information transfer within the DOD, many unanswered questions and complex problems related to the transition to the digital format remained. Therefore, the CALS directive and similar pertinent DOD directives related to the evolution of data representation processes will be discussed in this paper. Unresolved issues concerned with this data conversion and relating to the mass storage of this support documentation, will also be investigated in this research paper.

#### **D. NAVAL AVIATION TECHNICAL MANUAL EMPHASIS**

Due to the myriad of data management issues that can be analyzed within just the Navy's organizational structure, this research necessarily will concentrate on a specific area. Consequently, this preliminary feasibility study will investigate the directives and programs specifically applicable to the Naval Aviation technical manual publication methodologies. Furthermore, a detailed analysis of the alternative digital data storage and presentation methods applicable to the Naval Aviation technical manual arena will be conducted. This specified research area is a fairly representative segment of the DOD regarding data storage problems. The Naval Air Systems Command (NAVAIRSYSCOM) has been rather progressive in approaching this problem and has initiated several programs to automate the aviation maintenance system and its associated logistical support structure. These programs will be reviewed as applicable to the evolution or contribution to the digitization process of Naval Aviation technical manuals. A major unresolved issue, one of which is a significant topic developed in this paper, is the method to convert the literally miles of historical technical data files to the digital format. The raster scan process versus the vectorization method will be analyzed and detailed as a major objective of this thesis. Additionally, and more specifically, the emerging laser optical mass storage format will be analyzed for possible applications to solve this information deluge problem.

#### **E. THESIS TOPIC DECISION**

The optical mass storage technology is at best in its infant stage. In fact, after completing close to half of the requirements for the Computer Systems Management master's program at NPS, I was virtually unaware of the optical media potential not to mention the on-going optical media technology research applicable to and in some cases sponsored by the Department of Defense. I determined my thesis topic would relate to Naval Aviation technical documentation and the optical media alternatives while fulfilling a quarter project for a course titled Contemporary Computer Systems. Assigned to submit a paper and deliver a classroom presentation on the emerging field of optical mass storage technologies, I was immediately struck with how well suited optical media applications (particularly the CD-ROM format) related to the large scale technical publication environment of Naval Aviation. I contacted the Naval Aviation Technical Service Facility (NATSF) seeking sponsorship. Quite coincidentally, Mr. Jerry Gruden, of the NATSF Policy and Plans Division, was conducting preliminary feasibility studies on the electronic data distribution alternatives which included the

optical media option. The NATSF organization agreed to sponsor my research and funded a fact-finding research trip to the NATSF facility in Philadelphia and to several electronic data transfer research labs in the Washington, D.C. area that are investigating or implementing an optical mass storage system.

## **F. OBJECTIVE**

The objective of this research begins with a review of the evolution of weapon systems' support documentation development, publication and distribution methodologies. This evolution review will include a synopsis of pertinent DOD and DON directives related to the automation of this supporting documentation with particular emphasis on the Naval Aviation environment. The paper continues with the analysis of data digitization processes and mass storage methods and media alternatives. This research will specifically investigate the optical media solutions relating to the excessive costs, handling delays and administrative burdens associated with the present Naval Aviation technical manual distribution system.

## **G. RESEARCH QUESTIONS**

The following research questions represent the overall direction, organization and scope of this paper:

1. What DOD/DON directives and programs related to support documentation development and storage have contributed to the digitization process and data automation goals? (a review of the evolution of these programs and policies)
2. Does the optical mass storage media option have any practical applications in the military environment and in particular relating to the Naval Aviation publication distribution regime?
3. What are the implications of converting the present day paper or microfiche documentation libraries into the digitized format? (raster scan vs vector representation issues)
4. What are the implications of the revision or updating issues related to the optical storage technologies? (telecommunication possibilities for critical technical publication updates; cost and accountability considerations)
5. Will the present lack of optical technology standards become a major issue to military investment and applications?
6. What are the implications of the developing interactive multi-media optical storage techniques with regard to technical referencing, maintenance technician training and improved troubled-shooting and quality assurance actions?

## H. METHOD OF STUDY

A three-step methodology will be utilized in this research to determine a recommendation for continuation to a formal feasibility study:

1. Stage One: This stage will consist of an extensive literature search with particular emphasis on the following topics:
  - DOD/DON directives and programs related to the evolution of technical manual digitization and data automation
  - Specific optical media issues :
    - historical development - brief review of pioneering corporations' attempts to develop and market optical media: problems encountered, significance of the compact disc audio industry success and unresolved problem issues (standardization, text search and retrieval software efforts)
    - technological overview - basic 'nuts and bolts' issues, comparison of technology between both magnetic media and the several types of optical storage (advantages vs. disadvantages)
    - publishing applications - investigate the large scale publication environment and highlight the areas most susceptible to optical media implementation and in particular consistent with military applications
    - industry projections - cost reductions, improved and automated data retrieval development, multi-media discs applications, projected technology breakthroughs
  - Graphic or illustrative representation issues - non-textural digitization methods, CAD/CAM implications, raster scan vs vector format
2. Stage Two: This stage will analyze the Naval Technical Manual Publication and Distribution methodologies including: evolution of program; pertinent directives and charter; and short and long range plans to improve the system via electronic means. Additionally, this analysis will review those programs related to data automation and or the information digitization process including: the DOD directive titled Computer-aided Acquisition and Logistics Support (CALS), the Navy Technical Information Presentation System (NTIPS), the Maintenance Information Automatic Retrieval System (MIARS), and the Naval Aviation Logistic Command Management Information System programs (NALCOMIS). This stage will review the specific military applications (particularly the on-going research projects) dealing with the optical storage media field. This review will include the proposed optical storage implementation schemes and alternative solutions related to the data distribution and storage problems within the Naval Aviation environment. Stage Two included travel to the Naval Aviation Technical Services Facility (NATSF) as well as several Naval Research Labs and government contracted corporations developing optical media storage and publication projects related to NAVAIR technical manual administration.

3. **Stage three:** This stage will evaluate all the data reviewed in stages one and two and will offer an overall analysis of cost vs. benefits (maintainability, survivability, space and environment support savings), initial hardware investment estimates, security and standardization issues, future training implications of the interactive optical alternatives, indexing and data retrieval problems, text vs. graphic (illustrations and diagrams) digital representation issues and fleet acceptance. This stage will determine a recommendation (a 'go-no go' decision) for continuation to the prototyping stage for realistic cost estimation and system effectiveness.

## **I. SCOPE AND LIMITATIONS**

This research will serve as a first-step or preliminary feasibility study to determine the viability of the optical mass storage alternatives in relation to the Naval Aviation technical manual documentation digitization process. The advantages and disadvantages of the formats within this technology will be compared with particular emphasis aimed at the Naval Aviation technical documentation publication and distribution methodologies. A historical review of appropriate DOD/DON directives and the previously implemented programs aimed at automating Naval Aviation maintenance data retrieval and recording will be presented. An analysis of the completed, commercially developed CD-ROM Boeing 757 maintenance manuals developed for British Airways will be presented and screen dumps of this application will be included if approved by appropriate proprietary authority. Due to the immaturity of this technology, many companies did not have a completed cost study available or due to competitive pricing, were not willing to release cost comparisons or development investment on optical disc preparation. The majority of the literature review was constrained to periodicals due to the limited published references on this technology.

## **J. EXECUTIVE SUMMARY**

The increased sophistication of weapon systems has generated an exponential growth in the associated technical support documentation. This data explosion related to DOD weapon system support documentation is becoming unmanageable in its present form. The DOD has recognized this dilemma and embraced a joint DOD-industry study which culminated in the release of the Computer-aided Acquisition and Logistic Support (CALs) initiative. This directive required all current and future weapon systems' technical support documentation to be in a digitized format.

The Navy, whose operational constraints related to weight, space and environmental conditions are more critical than other DOD agencies, has long since recognized the need to solve this paperwork storage problem. The DON has been pursuing electronic data representation and information automation with programs such as the SNAP project and NALCOMIS development plans. The CNO has demonstrated strong support for the 'paperless' ship concept and with the release of OPNAV 5440 of FEB 1987, the CNO has assigned responsibilities for implementation of the DOD CALS initiative.

With the advent of optical mass storage media, a five foot stack of typewritten pages can be placed on one CD-ROM. The implications of being able to store such a massive amount of data on one 4.72 inch (12 cm) disc that is practically environmentally unalterable, deserve investigation. British Airways in cooperation with The Boeing Aircraft Company has opted to incorporate the optical (CD-ROM) technology for their next generation of aircraft by placing the new Boeing 757's aircraft maintenance and related manuals ( a multi-volumed, five foot stack of text and illustrations ) onto one CD-ROM. This research will attempt to determine if the commitment on the part of a major commercial aviation activity applies to Naval Aviation. Additionally, due to the advancements in the CD-ROM interactive environment, the possibilities of multi-media applications will also be investigated. There is presently available a technical manual that has been arranged on a CD-Interactive medium that displays a video, audio and textural presentation via a CRT screen. The quality assurance and training implications of this application related to the Naval Aviation environment are phenomenal.

### III. EVOLUTION OF DOD/DON DATA AUTOMATION DIRECTIVES

#### A. COMPUTER-AIDED ACQUISITION AND LOGISTIC SUPPORT (CALS) INITIATIVE

The eventual replacement of paper as the primary medium of communication coupled with the integration of an automated information system, have been the long range goals of the Department of Defense's Logistic Infrastructure since the proliferation of electronic data representation. As the sophistication and the accompanying support documentation of present and new weapon systems continues to grow, the method to store, transport and access this data has become a major problem and expense. In addition to this previously described data explosion problem, the growing demand for a unified, inter-service life cycle methodology relating to weapon systems acquisition and maintenance, supports the need for DOD standardized data support.

The Defense Department recognized the need to embark upon a goal of inter-service operability or data portability and embraced a joint Industry-DOD study aimed at recommending some solutions to this growing issue. This study, completed in late 1985, culminated with the release of the CALS (Computer-aided Acquisition and Logistic Support) Core Requirements Coordination Draft (PHASE I) [Ref. 4]. The CALS 'directive' endeavors to establish a standardization policy relating to the development, acquisition and maintenance of weapon systems' support documentation. The underlying motive for this 'directive' is to provide an integrated set of program requirements with accompanying guidelines, procedures and standards to facilitate contracting for digital data in weapon system and data system acquisitions. Directed at Military Department and Defense Agency program offices, the requirements provide a common baseline for future technical data acquisition. As such, the overall objectives of the CALS Core requirements:

. . . embodies a strategy to develop networks of shared systems between industry and government, using "intelligent" data as the exchange media. The program's goal is full and total implementation within a ten year plus time frame. [Ref. 4: p. 3]

Embarking upon such an ambitious project, even over this proposed ten year period, requires an awesome managerial effort. The fact that this 'directive' is a draft proposal not yet fully sanctioned or approved by the DOD is noteworthy. Trying to formulate a standardization policy within just one defense agency by itself is a major milestone. Trying to establish a standardization policy of such far-reaching magnitude across the entire DOD organization may in itself prove to extend beyond the ten years planned for the entire CALS package implementation. Accordingly, this objective is predicated upon a long range phase implementation program [Ref. 4: p. 3] that will ultimately link the entire military logistical infrastructure to foster:

- Streamlining and integration of selected weapon system functions pertaining to design and logistic support
- Minimizing data redundancy and maximizing data integrity, consistency, and traceability
- Increasing effectiveness and efficiency in the inter-organizational exchange of digital data among the DOD and the defense contractors

The CALS goal is to be realized in two major stages. Phase I is concerned with the 'system architecture', or the 'hardware' interfacing of the myriad computer systems and applications currently utilized within the DOD. The evolution of the Defense Data Network, its standardization efforts, inter-service proliferation and acceptance is an example of this first phase goal. Phase II is more concerned with the 'data management' issues. The access, ownership and general database distribution policies and format standardization are examples of Phase II considerations. This phase will additionally set integration standards for emerging technologies. Phase II will emphasize the implementation of on-line database interaction vice the file bulk transfer exchanges accentuated in the earlier phase.

The scope of the CALS program encompasses the entire weapons system procurement process from the preliminary mission element needs statement to final delivery of the technical support documentation and the revisions associated with this disseminated information. This spectrum includes any automated data processing action applicable to weapons system acquisition. Some examples include:

- an agency's request for proposal (RFP) is presently listed in specified government periodicals. The CALS directive would enable this information to be 'sent' by digital representation via electronic mail to those corporations subscribing to the appropriate 'bulletin board' service on a joint DOD-industry supported network.

- an illustrated parts bulletin (IPB) data base developed on a CAD/CAM vector format system with text portions complying with the SGML (Standard Generalized Mark-up Language) text structure and format coding standard.
- a logistic support structure designed with an automated supply transaction interface.
- An example related to this research includes quarterly revisions of a Naval aircraft maintenance manual mailed on a CD-ROM with rapid action maintenance engineering changes (RAMECS) sent via telecommunication link and stored on a magnetic floppy for indexing overlays.

Although many specific data representation and transmission standardization requirements are presented in the CALS draft, various general issues [Ref. 4: p. 6-9] that have yet to be resolved with a final, approved CALS directive include:

- Data Security - transmission of classified / proprietary data and authority to modify or update contractor data comprise several data security issues
- Contractual Statement of Work Language - format and distribution policies for functional requirements and contractor bids/proposals for contract decisions
- Graphical or Technical Illustration Representation - formats and standards for non-textural information needs to be addressed promptly as CAD/CAM weapon system development is becoming commonplace in the aeronautical environment (vector representation issue)
- Data Compaction and Consolidation - with the advent of less expensive magnetic media memory and the laser disc technologies, data intensive but elegant 'three-dimensional' engineering drawings that can be manipulated (rotated , reduced or magnified) are now available, however, government contractors need standardization guidelines (CAD/CAM issue)
- Digital Conversion of Archival (paper or microfiche based) Technical Documentation - the raster vs vectorization options for the digital conversion of the numerous repositories of non-digitized records and drawings is a major issue that is discussed and is identified as an immediate decision item
- 'expert' systems - 'intelligent' (decision support) data resident in knowledge bases and interactive or advanced telecommunication applications are examples of the iterative technologies that justify CALS implementation flexibility

The optical technologies are discussed in both the CALS directive and the MIL-STD-1840A, but to illustrate the immaturity of this topic, OD3 (optical digital data disk) is described as an evolving technology that has yet to stabilize sufficiently for standardization.

In Conclusion, the CALS and MIL-STD-1840A are quite technically specific and detailed in describing formats, protocols, data exchange procedures, etc. However, because so many digital data issues are still evolving in a very dynamic manner, many

appropriate or efficient standards set today may well be obsolete within a year. The CALS program attempts to solve this dilemma by establishing general guidelines vice specific standardization policies for the more iterative and less crucial issues. The 'directive' defers setting a standard on these issues until the technology stabilizes or matures. As noted, some issues require immediate government initiated standardization. In many cases, this commitment by the government or more specifically by the DOD, may actually set the industry standard and force stabilization of that area.

Most significantly, CALS is functioning as a general guideline or 'umbrella', which has identified the major problems associated with data digitization standardization. The CALS core requirements package is flexible enough at this stage to give each of the individual services enough leeway to make specific inputs to a final standardization policy while enabling a gradual transition of present and under development weapon systems to a digitized data format. Each of the separate services have established technical documentation automation programs that will be influenced by this initiative when fully sanctioned. Examples of these programs include: two Army's projects--TIMS (Technical Information Management System) and EIDS (Electronic Information Delivery System); the Air Force's project ATOS (Automated Technical Order System); and the Navy's project NTIPS (Navy Technical Information Presentation System).

#### **B. THE NAVY TECHNICAL INFORMATION PRESENTATION SYSTEM (NTIPS)**

The Navy's NTIPS program is a comprehensive effort to identify the problems and define solution parameters associated with the technical information development, organization and distribution policies. This program encompasses all technical documentation associated with the operation, maintenance, training and logistical support of Navy systems and equipment. This program was in response to repeating technical information deficiencies in the fleet, recognized by several readiness review organizations as early as 1977. Following inputs from numerous fleet commanders echoing this technical documentation problem, the CNO established an R&D program on technical documentation improvement that evolved into the NTIPS program. Some of the deficiencies identified by this study [Ref. 6: p. 1.3.1] include:

- Increasing complexity and volume of TI (technical information) coupled with decreasing reading and comprehension ability of Navy personnel

- Delays in providing initial documentation and in updating documents to correct errors and reflect configuration changes
- Inconsistencies between technical documentation for training and technical documentation for maintenance
- Excessive number of errors and other inadequacies in TI
- Escalating costs of developing and distributing TI

The NTIPS study evolved into an automated technical documentation delivery system analysis. This shift resulted as the issues developed in Chapter II of this paper (data 'explosion' and 'paperless' ship concept) became more apparent. In addition to these previously briefed documentation considerations (cost, weight, space and updating issues), this study was driven by the exponentially decreasing costs of electronic data representation, storage and distribution. This drastic cost reduction enabled large scale DOD computer implementation and elicited new technical documentation development and distribution procedures. This windfall accelerated the automated electronic delivery design process and evaluation stages.

During FY 1978, various prototype data automated applications were implemented throughout various command environments for NTIPS System concept analysis. The major players involved in this evaluation included the Navy Systems Commands and the Navy Training Commands. A sampling of the prototype programs implemented during this evaluation period include: a NAVAIR project writing emergency procedures found in pilot's manuals, a NAVSEA program which developed and implemented the modular specification concept and the Training Community's adoption of a computer authored program to write course material on Morse Code for signalmen and the development of 23 computer-aided lessons for aerographer's A-school instruction.

In late 1979 and early 1980 Phase IIA of the five total phases of the NTIPS schedule included an analysis of these programs. The preliminary results of this study indicated significant benefits and potential related to electronic presentation and distribution methods. This phase concluded with the preliminary system concept report [Ref. 6: p. 1.6.1] which outlined the following major or long range research objectives:

- define the interface between the Integrated Logistic Support Process and NTIPS - use of a common, on-line database
- incorporate an NTIPS interface with the Training Community to ensure training and operational compatibility in maintenance procedures

- investigate the possibility that a fully-automated, digitally-based NTIP system can provide and control variable media presentations
- Resolve the implications of an all digital system which will:
  - permit matching the TI to varying degrees of user experience levels
  - be amenable to proceduralized jobs
  - make TI update and configuration management easier
  - be capable of collecting data on maintenance efficiency and trend analysis
- develop the concept of modular specifications in which a computer will be used to select and compile individual requirements statements for each kind of TI as specified by the NTIPS user
- develop a computer-authoring concept in which the computer is pre-programmed to write course material
- research benefits of an automated publishing system (estimated annual savings for the Training Community is \$ 700,000)

With the release of the System Development Plan (SDP) [Ref. 6: p. 1.4.1 - 1.5.1], Phase III established the following NTIPS primary goals and objectives specifically related to the operators and maintenance technician's perspective:

- Technical Information (TI) quality and consistency - The User-TI Match process will ensure new TI will match user ability and present information in a format suited to user job tasks and working environment.
- Accuracy of the TI - Improved quality assurance procedures, speedier correction of errors and resolution of configuration mismatches.
- Homogeneity of the basic technical content presented to users - Job TI will first be encountered at service schools ashore, later in shipboard or squadron training and finally in working assignments. NTIPS will provide coordination and integration for training, operation, maintenance and logistic support tasks.
- Efficiency of TI preparation and control - More efficient, standardized methods of generation, replication, distribution, feedback and update are inherent in the NTIPS underlying policies of digital data generation and transportability.
- Opportunity to apply cost savings resulting from NTIPS to improve Fleet readiness in other areas - The Navy currently (1982) maintains a \$5 billion TI inventory and spends millions of dollars on TI annually. Savings in TI acquisition and update costs would be significant.
- Re-evaluate state-of-the-art technologies related to TI generation, distribution and control, coordinate with developing DOD directives relating to technical documentation acquisition and digitization.<sup>1</sup>

---

<sup>1</sup>During the later phases of the NTIPS program, the DOD indicated a data digitization standard study was being initiated. This study resulted in the DOD CALS 'directive' published in 1987 and discussed in section A of this Chapter.

- Consider evolving human factors and supporting technologies - include human engineering principles, define information philosophies and establish presentation methodologies consistent with current research in the design of both hardware and software support systems.

In conclusion, the NTIPS program was the Navy's initial attempt to standardize and integrate the proliferating technical support documentation. The program generated into a data digitization feasibility study as a result of several overlapping System Commands' independent ADP programs initiatives such as NAVAIR's MIARS program, NAVSEA's SNAP series and NAVSUP and NAVAIR's joint efforts in the NALCOMIS program. An NTIPS phase report concluded that the benefits and potential of automated electronic data presentation systems mandated prompt development followed by major command, large scale implementation. This program, in conjunction with those similar automated technical documentation programs of the Navy's sister services mentioned in section A of this Chapter,<sup>2</sup> set the precedent for the DOD CALS initiative.

---

<sup>2</sup>The Army's TIMS and EIDS projects and the Air Force's ATOS program

## **IV. EVOLUTION OF NAVAL AVIATION TECHNICAL MANUAL DATA AUTOMATION**

### **A. AUTOMATED DATA SYSTEM BACKGROUND**

The Kennedy Administration of the early 1960's, influenced by Secretary of Defense Robert McNamara, implemented a Department of Defense weapon system acquisition program similar to that of a Fortune 500 corporation. This initiative was an attempt to transition the DOD from a non-profit like organization to a fiscal accountable environment. Bringing the management style and budgetary concepts he used as Chief Executive Officer of Ford Motor Co., McNamara applied innovative fiscal policies to control or at least account for the spiralling costs of weapon system acquisition. It soon became clear that due to the complexity of new weapons systems, new methods of control and evaluation relating to system acquisition were needed. Trying to determine the success of a weapon system acquisition, however, was in itself a major milestone because of the inadequate measuring methods previously utilized. Terms such as "cost effectiveness" and "readiness vs. cost" became prominent among DOD management personnel. The emphasis towards project management, life cycle management, cost-benefit analysis and the long term maintenance considerations began with this movement. The data management problems induced by these new program performance measurement techniques and the resultant requirements for data collection, analysis and dissemination became a major issue.

Another major issue associated with the increasing costs and sophistication of new weapons systems and related to their long-term support was the exponential increase of technical and logistical support documentation relating to the development, operation and maintenance of these systems. This put an overwhelming burden on a management information system that was already becoming unmanageable.

The DOD recognized this data management dilemma and pursued new concepts to automate the collection, analysis and distribution of required data. This general Defense Department initiative generated a multitude of new programs aimed at alleviating this data management problem.

The DOD acquisition policies continued to evolve in regards to fiscal accountability. Rather than continuing to place primary emphasis upon the operational capabilities of a system and the minimization of acquisition costs, the

concept of life cycle management emerged to become the predominate acquisition policy. This concept stressed the need for closer coordination between prime equipment development and logistic support analysis with more emphasis being placed on the incorporation of supportability into the weapon system design. This emphasis shift was a result of the cost increases related to the maintenance of weapons systems (spare parts, technical documentation, logistic overhead, etc.) which often became the greatest expense of new weapon system acquisition.

As the military industrial complex grew, the weapon systems' design and acquisition processes coupled with operational and logistical interfaces completely overwhelmed current data management methods. Cost overruns, contractor misappropriations or erroneous charges, project management snafus and grossly flawed final weapons packages required the DOD to take action to alleviate these routine occurring problems. Military Standards such as MIL-STD-1388-1A Logistic Support Analysis (LSA) guideline and MIL-STD-1388-2A LSA Record (LSAR) guideline were products of the DOD's efforts to control the subsequent maintenance and logistical support mismanagement problems following weapon system implementation. The CALS directive consolidated many of these logistical guidelines and implemented the digitization requirement for weapon system acquisition.<sup>3</sup>

During this same period and leading up to the CALS initiative, the advances in computer technology accounted for many research projects investigating the automation of data management. The Navy recognized the need for a standardization program and released OPNAV Notice 5440 which directs full support of the CALS initiative. This notice delineated the Navy's CALS implementation responsibilities and was prefaced with the following capsulated information on the Navy's weapon system acquisition environment and CALS support policy:

a. Current and emerging computer technology provides the opportunity to significantly reduce the costs and improve the effectiveness of designing, producing and supporting weapon systems. A controlled and well planned application of this technology is required to ensure optimum compatibility between individual systems, reduce costs by standardization wherever practicable and to ensure implementation of computers within the logistics infrastructure is responsive to user needs.

b. CALS is an integrating mechanism for a modernization process that is underway in the Navy today. The process of developing and transitioning current and emerging computer technology to design and support weapons

---

<sup>3</sup>See CALS initiative Chapter III, section A.

systems by using digital logistics and technical information presents an enormous challenge. Technical information is the life blood of logistic support. The Navy is starting down the road which may ultimately result in the near-paperless logistic environment. The process may take decades. Not one, but a number of technical transitions will have to be achieved while maintaining the responsiveness and effectiveness of logistic support. An architecture must be established and controlled; explicit standards must be developed and adhered to; detailed implementation schedules must be designed and precisely controlled. [Ref. 7]

Prior to the CALS initiative, the Navy's initial efforts to modernize maintenance management and logistical support resulted in the 'birth' of the 3-M System (Maintenance and Material Management System). The 3-M System or more specifically, the Aviation 3-M System, was one of the first data collection programs to be developed around an Electronic Accounting Machine (EAM). Because of the limited computer technology and the severely restricted telecommunication environment of that era, most of the data collection, analysis and distribution was done manually. As ADP technology improved, much of this inefficient and error-prone data transference became automated. This data automation process is still evolving, however, the initial aspects and objectives of the 3-M System served as the fundamental guideline through many iterations and follow-on programs. One of the stronger points of this program was the establishment of a standard system throughout the Navy for coding logistic information. Another baseline attainment was the implementation of a system that utilized historical data for trend analysis.

The Aviation 3-M System did have some deficiencies that received some high level attention. Aside from the ineffective man-machine interfaces relating to data collection and processing referred to previously, specific shipboard aviation readiness concerns related to aircraft maintenance and support surfaced during the Viet Nam Conflict.

In 1970, the CNO established the Carrier Aircraft Maintenance Support Improvement (CASMI) Project to identify priority actions to improve carrier aircraft readiness. Analysis of the CASMI Project concluded that a significant readiness improvement could be achieved through increased efficiency in the management of those functions associated with shipboard aircraft maintenance and support. Further analysis concluded that the most practical and cost effective means of attaining an acceptable level of efficiency in those functions would be through improved use of automated data processing equipment (ADPE). [Ref. 8: p. vii]

The movement towards Naval Aviation data automation was evident in the several overlapping projects being conducted during this period. The CASMI project eventually evolved into the NALCOMIS Development Program which was designated to consolidate the various projects relating to Naval Aviation data automation. The Navy's Maintenance Information Automated Retrieval System (MIARS), a parallel technical documentation automation program that was being implemented as an interim paperwork reduction program, is pertinent to this research and will be reviewed prior to the analysis of the NALCOMIS program.

## **B. MAINTENANCE INFORMATION AUTOMATED RETRIEVAL SYSTEM (MIARS)**

The MIARS program, initiated by OPNAVINST 4790.1, was Naval Aviation's attempt to automate the technical documentation process and retrieval methods prior to the digitization initiatives addressed in the CALS directive. The MIARS project was a consolidation effort that combined several research programs designed to transform hardcopy technical documentation into usable microform. The very same issues or problems associated with technical documentation identified in this paper were driving factors in the development of the MIARS project in the late 1960's. These issues include the weight and space savings and revision considerations of a paperless media and automated retrieval system. Forming the basis and hardware support of the MIARS program were separate data automation and retrieval research programs which include: the Weapons System Maintenance Action Center (WSMACS); a special Naval Aviation Rework Facility (NARF) designed microfilm storage and retrieval system; Rapid Automated Problem Identification System (RAPIDS); Engineering Data Management Information Control System (EDMICS); and Technical Manual Management Information Control System (TMMICS). These systems eventually evolved either as a prototype system, a future enhancement or new application under the MIARS consolidation. The most significant feature of these systems was the ability to store and retrieve microfilm reels. A typical scenario of a MIARS application would see the user (maintenance technician) consulting a published, hardcopy index to obtain a binary code for the section of a maintenance manual desired for reference. The user would enter this code into the WSMACS machine and the appropriate microfilm cartridge (reel) would be selected, searched and the 'desired' technical information would be displayed on a microfilm display screen.

A refinement to the MIARS program included a telecommunication link for technical illustration and revision transmittal. The Technical Manual Management Information Control System (TMMICS) coupled with the Engineering Data Management Information Control System (EDMICS), envisioned an AUTODIN network system originating from a central location (NATSF in Philadelphia). This network would link the entire fleet, including deployed afloat units, by telephone and or satellite. All technical information, including drawings relating to a particular weapon system, would be stored in the central computer. Remote requests for text, drawings or updates would be processed via telephone lines and an auxiliary reproduction system (ie. facsimile process) would then deliver the requested information to the remote site. The TMMICS program actually proposed an early adaptation of the digitization process directed by the CALS initiative. The system was to optically scan the microfilm at the central library, digitize the text, transfer this code to magnetic tape and transmit this data over the AUTODIN network.

The MIARS project was an ambitious, innovative and even logical program that unfortunately (or perhaps fortunately) never got off the ground. The program was 'partially' implemented by the Naval Aviation Maintenance Program (NAMP-OPNAV 4790.2 and included in the NAVAIR Technical Manual Series NAVAIR 00-25-100 15 December 1984 - Naval Air Systems Command Technical Manual Program. This handbook, published in the standard Work Package format delineated by this same NAVAIR manual, devotes a chapter to the MIARS procedures and related information on system operation and maintenance. Not the least of the obstacles or events that precluded full implementation was the exorbitant costs associated with both the hardware acquisition and information preparation. Additionally, the technological advances forecasted by the MIARS program were never realized. Several other issues contributing to the demise of this project include: the security issues associated with the transfer of technical data over a telecommunication line, intense competition for already limited satellite and worldwide AUTODIN resources and the technological advances of data digitization processes. This digitization advancement coupled with the CALS publication has virtually obsolete all microfilm data representation systems presently employed by the DOD. The feedback from early prototype experiments were also not very encouraging. Maintenance technicians complained of poor indexing, long access times and poor quality hardcopy reproductions that ended up accumulating in the workspaces. In order to avoid using

the MIARS equipment, the maintenance technicians would often compile a 'local' filing system of the hardcopy printouts. This circumstance defeated a major purpose of the system - eliminating or at least reducing the paperwork storage problem while ensuring the most current maintenance procedures are being performed.

In conclusion, The MIARS program had good intentions and goals but was ill conceived. The poor timing of this project in relation to the technological advances of the digitization process coupled with the poor hardware maturation schemes, precluded full system implementation.

### **C. NAVAL AVIATION LOGISTIC COMMAND MANAGEMENT INFORMATION SYSTEM (NALCOMIS) OVERVIEW**

As previously stated, The NALCOMIS program was a parallel albeit more encompassing effort consolidating the various but similar programs attempting to automate Naval Aviation data management. The MIARS and the Naval Aviation segment of the NTIPS program are examples of the systems that ultimately fell under the cognizance of the NALCOMIS Automated Data System (ADS). While the NTIPS program deals mainly with the technical information presentation issues of the entire Naval Service environment, the NALCOMIS charter is concerned with providing a fully integrated, modern management information system for the Naval Aviation community.

The CNO study resulting in the CASMI Project,<sup>4</sup> initiated a joint NAVAIR and NAVSUP venture which established the Shipboard Aviation Command Management Information System (SACOMIS) in April 1972. In March of 1974, CNO (OP-91) gave concept approval to the SACOMIS Automated Data System (ADS). Shortly after this concept approval and following a detailed task effort undertaken by a working group comprised of the Management System Development Office (MSDO) and Fleet Material Support Office (FMSO), CNO (OP-51) directed that SACOMIS be expanded to include Naval Air Stations (NASs), Marine Air Groups (MAGs), LPHs, LHAs, and Marine Air Corps Stations (MCASs). Re-named NALCOMIS, Commander, Naval Air System Command (AIR-195), was assigned as project manager. The CNO emphasized that NALCOMIS was a priority action for improving and sustaining aircraft readiness and established a steering committee called Fleet Oriented Review Committee Evaluating Naval Aviation Logistic Systems (FORCES).

---

<sup>4</sup>previously mentioned in section A of this Chapter

CNO OP-52 joined OP-51 as a co-sponsor in November of 1974. A year later, a draft of the NALCOMIS ADS Plan was completed and informally reviewed by the appropriate Navy/Marine Staff Components. The NALCOMIS project was designated a major weapons system by the CNO in accordance with OPNAVINST 5000.42A. This designation action along with the primary objectives and scope are capsulated in the NALCOMIS ADS Development Plan preface:

In March 1976, Program Management was shifted to a newly established organization entity within NAVAIR designated as Aviation Program Coordinator (APC-5), whose sole function was to manage the NALCOMIS development effort. As a result of the comments received from the staffing, it was decided to utilize the modular approach in developing the total NALCOMIS program. Accordingly, the initial scope of NALCOMIS, identified as Module 1, is limited in design to provide a modern Management Information System in support of the Organizational Maintenance Activity (OMA), Intermediate Maintenance Activity (IMA) and Supply Support Center (SSC) functions (afloat and ashore) in accordance with the OPNAV 4790 NAMP Instruction. [Ref. 8: p. A-1]

Module 1 of the NALCOMIS ADS addresses the urgent requirement that exists to modernize and to standardize the numerous information systems that attempt to support U.S. Navy and Marine Corps aviation maintenance and material management at the base level. The predominate problem faced by the Naval Aviation Logistic Community is that many aircraft are not meeting CNO minimum standards for mission capability (MC) despite the efforts of Integrated Logistic Support (ILS) managers to improve the rate. The NALCOMIS project is a phased development plan that includes a primary objective of implementing a modern MIS to reverse this trend. The present MIS currently in use at the OMA, IMA and SCC sites is made up of a variety of manual data collection procedures, manually prepared messages and partially automated systems. The collection of source data and its translation into machine readable form has remained virtually unchanged for the past decade. The NALCOMIS Mission Element Need Statement expands on this current NAMP MIS environment and identifies the major deficiencies:

While the management information system prescribed by the NAMP is conceptually sound having evolved over the past twenty years, it is cumbersome and labor intensive and becomes more so as the size, complexity, or operational pace of the unit increases. Further, the procurement of increasingly sophisticated weapon systems is placing a greater strain on the current information system by requiring more complex management skills and more timely and complete

information while staying within manpower and budget constraints. There are three major deficiencies in the current system: an inadequate real-time management information system; a difficult data collection process; and inadequate upline information. [Ref. 9: appendix A p. 1-2]

The overall goal of the NALCOMIS project is to implement a modern MIS for the Naval Aviation Community. The specific objectives needed to achieve a baseline system and identified for Module 1 [Ref. 8: p. A-4] include:

- Develop a single, integrated, real-time automated standard MIS to assist aviation maintenance and material managers in their day-to-day operations and decision making.
- Develop automated source data entry techniques for data input by aviation maintenance and supply personnel.
- Develop a first-stage, simplistic MIS with requisite capabilities to support the data requirements of certain Navy and DOD programs with less impact on the base level maintenance and material support functions.

The NALCOMIS project cannot be reviewed without a brief mention of its relation with the Standard Non-tactical Automated Data Processing (SNAP) program. NALCOMIS is basically the third phase or the final software interface completing a Naval Aviation Logistic management information network initiated by the SNAP I and SNAP II hardware implementation phases.

SNAP I was to provide replacement hardware for the AN UYK-5(V) procured in the late 1960's. This replacement hardware was the basis for furnishing real-time, interactive capabilities for larger ships, Marine Air Groups and selected shore sites. SNAP II continued this hardware implementation process, outfitting smaller ships and submarines with ADPE and interactive, real-time capabilities.

As stated, the NALCOMIS project was to 'link' these hardware platforms together to provide a fully automated system to support the Naval Aviation Maintenance Program (NAMP). A major obstacle of the NALCOMIS implementation process was the 'tailoring' of the software to an non-existent hardware environment that was not functionally analyzed for NALCOMIS support requirements. This obstacle was further aggravated when the hardware implementation schedule slipped by 18 months (contract award delay) and the software development commenced on a proposed, 'generic' operating system. Once the hardware system was identified, the pre-developed software would then be converted to run on the SNAP ADPE. In a prototype testing at MCAS Cherry Pt. in July of 1983, the converted software, running on the SNAP I contracted and delivered hardware, proved to be

unacceptable. This was due, in part, to the software conversion incompatibilities and delay time overhead not accounted for in the initial functional specifications of the SNAP I hardware acquisition process. The software had to be redesigned to accommodate the limitations of the hardware while retaining the functional design developed for SNAP I. "This 'native mode' development was estimated to complete prototype testing for the IMA and SSC portions in the fourth quarter, FY85 and for the OMA portion in the following quarter" [Ref. 10: p. 3].

#### D. NAVAL FLIGHT RECORD SYSTEM (NAVFLIRS)

Another integral part or major objective of the NALCOMIS program was the development of an automated single-source data entry system related to flight data. As Summarized in the Functional Description of the Naval Flight Record System [Ref. 11: p. 2-1]:

Flight data is the most significant source of information in Naval Aviation. All echelons of command use it for the following types of management decisions:

1. Asset Budgeting and Funding Allocations.
2. Aviation Safety Analysis.
3. Flight Program Assessment.
4. Aircraft Utilization/Employment.
5. Engineering Evaluations.
6. Maintenance Support.
7. Logistics and Provisioning.
8. Organic Airlift Capability.
9. Individual Aircrew Accomplishments.

The goal of the Naval Flight Record System (NAVFLIRS) is to integrate the data collection and correction procedures and programs used in the Maintenance Data System (MDS), Individual Flight Activity Reporting System (IFARS), Navy Air Logistic Information System (NALIS), and Flight Readiness Evaluation Data System (FREDS) into a single, locally controlled data entry system.

The objectives of NAVFLIRS [Ref. 11: p. 2-2] will be to provide procedures and programs for a standard DON flight activity data collection system. The system will:

- a. Establish a single flight activity form.
- b. Establish a central flight activity data base.
- c. Provide more accurate data.

- d. Eliminate discrepancies caused by different sources of flight data.
- e. Provide data timeliness.
- f. Increase data validity.
- g. Provide Local flight activity reports.
- h. Eliminate redundant data documentation and processing.
- i. Improve and automate local documentation of enlisted aircrew training.
- j. Provide improved documentation of opportune logistics activities.

#### E. NAVAL AVIATION DATA AUTOMATION SUMMARY

It is clear to see that with the exponential increase of technical documentation coupled with the proliferation and technical advances of electronic data representation, the data distribution environment has become a very dynamic and critical issue. The Naval Aviation community, or the DOD in general, has taken a rather conservative approach to the implementation of data automation systems. Unlike many previous technological developments attributable to governmental funding, the maturation and financing of the computer industry has been predominately confined to the private sector. The DOD/DON have assumed this conservative approach to data automation due to several abortive attempts to implement a large scale, automated information system. These unsuccessful efforts were usually a result of technology overcoming or obsoleting a designed system<sup>5</sup> or from functional requirement changes that occurred late in the development stages of the acquisition process. These late occurring functional requirement revisions were usually effected to take advantage of a radical technological breakthrough. This wait-and-see stance has benefitted the DOD by saving significant R & D expense. The trade-off to this savings, however, will be the catch-up efforts the DOD/DON will have to expend to match the data automation level enjoyed by many large scale corporations. The CALS initiative signalled the Department of Defense's shift to digitized data representation and signifies a major turning point for data automation realization. The DOD/DON is presently engaged in this transition, a period which will be extensive and costly but required if the objectives set forth in the NALCOMIS charter are to be achieved.

The Naval Aviation community has recognized the need to implement a large-scale management information system. The NALCOMIS project, in conjunction with the SNAP I and II projects, was designed as the vehicle on which the first stage of this

---

<sup>5</sup>As was the case with digitization technology relating to the MIARS program of automated microfiche retrieval, see Chapter IV, section B.

goal is to be fulfilled. The first stage objective integration of the OMAs, IMAs, SSCs, aviation shipboard platforms and shore-based air stations with real-time operational data<sup>6</sup> will establish a new era for Naval Aviation management. This data automation mechanism has incredible controlling /monitoring potential. The implications of: immediate trend analysis; identifying supply bottlenecks; distributing immediate engineering changes or hazards to flight information; monitoring flight hour accountability; analyzing shipboard aviation supply load-out requirements; accounting for aviation weapon systems' spare parts or fuel usage are just a very few examples of the benefits that will be realized from this MIS.

The key to such large scale integration and implementation is a realistic information system phase-in program and consistent/stable functional requirements being maintained throughout the entire acquisition process. The DOD/DON must continue to maintain a conservative approach to new technology implementation. At the same time, due to the immense amount of electronic data storage required by the digitization process and the exponential growth of technical documentation, the DOD/DON must investigate and be ready to implement the new mass storage technologies. The potential benefits the optical media mass storage technologies offer, may well be the key, if the Navy's data automation goals and 'paperless ship' concept are to become a reality by the 1990's.

---

<sup>6</sup>flight and training data via an automated NAVFLIRS system; maintenance and logistical transactions via an automated visual information display system maintenance action form (VIDS/MAF)

## V. OPTICAL MASS STORAGE OVERVIEW

### A. OPTICAL MASS STORAGE INTRODUCTION

The optical mass storage environment is a new, rapidly developing and iterative technology. Initially conceived for micro (personal) computer external storage device improvement in the area of large-scale data storage and direct/random access, the technology transcended to large-scale computer usage. Unlike several previous storage technology 'break-throughs',<sup>7</sup> the optical storage industry has delivered on the majority of its promises. As immature as this technology is, many established companies are investing heavily into the research and development of this medium. Corporate names such as Sony, 3M, Xerox, NEC, Hitachi, Philips, Toshiba and more recently even 'Big Blue' IBM, have entered the optical storage development arena. In fact, the more sophisticated models of IBM's just released PS/2 micro computer family, will have an optional optical disc drive available.

. . . also announced but not yet delivered, is the IBM 3363 optical disk drive. This write-once, read-many (WORM) drive uses a 13cm (5.25-inch) form factor to produce 200 megabytes of storage. . . . One or two drives may be attached to the controller card and as many as four cards may be attached to the PS/2 60 or 80 models. Thus, as much as 1.6 gigabytes of storage can be accessed through this method. [Ref. 12: p. 8]

Like the magnetic storage media, the optical data storage media has three basic formats or methods of data delivery: read only, write-once / read-many (WORM), and the erasable or alterable formats. Each format uses different laser technologies to read and/or store the data on differently constructed discs.

A common misconception related to the optical storage implementation schemes, generated by the term optical, is that data is stored by image as in a microfiche application. Optical storage systems use a laser beam system to store and retrieve digitized data. The basic process involved in the optical storage application utilizes a laser beam and various optical combinations to focus and 'burn' a submicroscopic pit into a light sensitive substrate or similar recording medium. Depending on the method or format, this 'pit' or a stamped replica (as in the CD-ROM disc) is then 'read' when

---

<sup>7</sup>bubble memory research of the 1970's was touted as the next generation of mass storage applications, however this technology did not eventuate as proclaimed

a lower-powered laser is directed upon the disc groove. The reflected, modulated light is then interpreted into appropriate binary representation.

In discussions regarding optical mass storage technology, these previously mentioned but different formats: the various write-once, read-many (WORM) systems; videodisks; read-only systems--optical read only memory (OROM) and compact disc-read-only memory (CD-ROM); and the erasable format, are often lumped together. Although all these formats utilize laser technology to read or 'write' to disk surfaces, the methods and mechanisms employed by these different technologies are so different, the user can easily become confused. A more technical explanation of all these technologies will be offered in section C of this Chapter--technology review.

There are many uses for optical storage, and the application of these different technologies varies with the storage environment. The most beneficial application for the optical media is the storage of massive data bases and image drawings due to the low storage cost per bit. As such, organizations with extensive paper production and storage requirements, like the U.S. Government, insurance companies and banks, will find this cheaper mass storage profitable. One significant disadvantage of the optical storage media, is the relatively long data retrieval access times as compared to the magnetic formats. This drawback is expanded upon in an article specifically referring to the CD-ROM format but applicable to the entire spectrum of optical storage:

The very quality that makes CD-ROM so attractive--vast storage capacity--is also its biggest drawback. . . .having Gigabytes of data available on a PC is all very well, but how do we locate any one specific piece of information? To help find needles in the CD-ROM haystack, a visionary idea promises to mark hundreds of paths through the straw: hypertext. . . .Hypertext approaches data storage associatively. [Ref. 13: p. 245]

The hypertext concept links key words and subjects areas which in turn offers the user a selection to 'paths' within the data. This concept requires each document to be indexed individually, and the connecting links must be manually formulated by individuals who are familiar with both the subject matter and hypertext methods. The optical storage research labs are continuing work on this dilemma and some software solutions such as an automated subject and index cross-checking authoring system and similar 'artificial intelligence' approaches are showing promise.

Perhaps the most advantageous or cost effective optical storage application is that of the CD-ROM format relating to the publication industry (software, historical

data base--i.e., corporate financial profiles, textbooks), where the large scale distribution of archival or non-volatile information is a major segment of a company's operation. Reference works, such as an encyclopedia, a dictionary-thesaurus combination, or a medical reference text, are examples of the type of environment that favor the CD-ROM format.

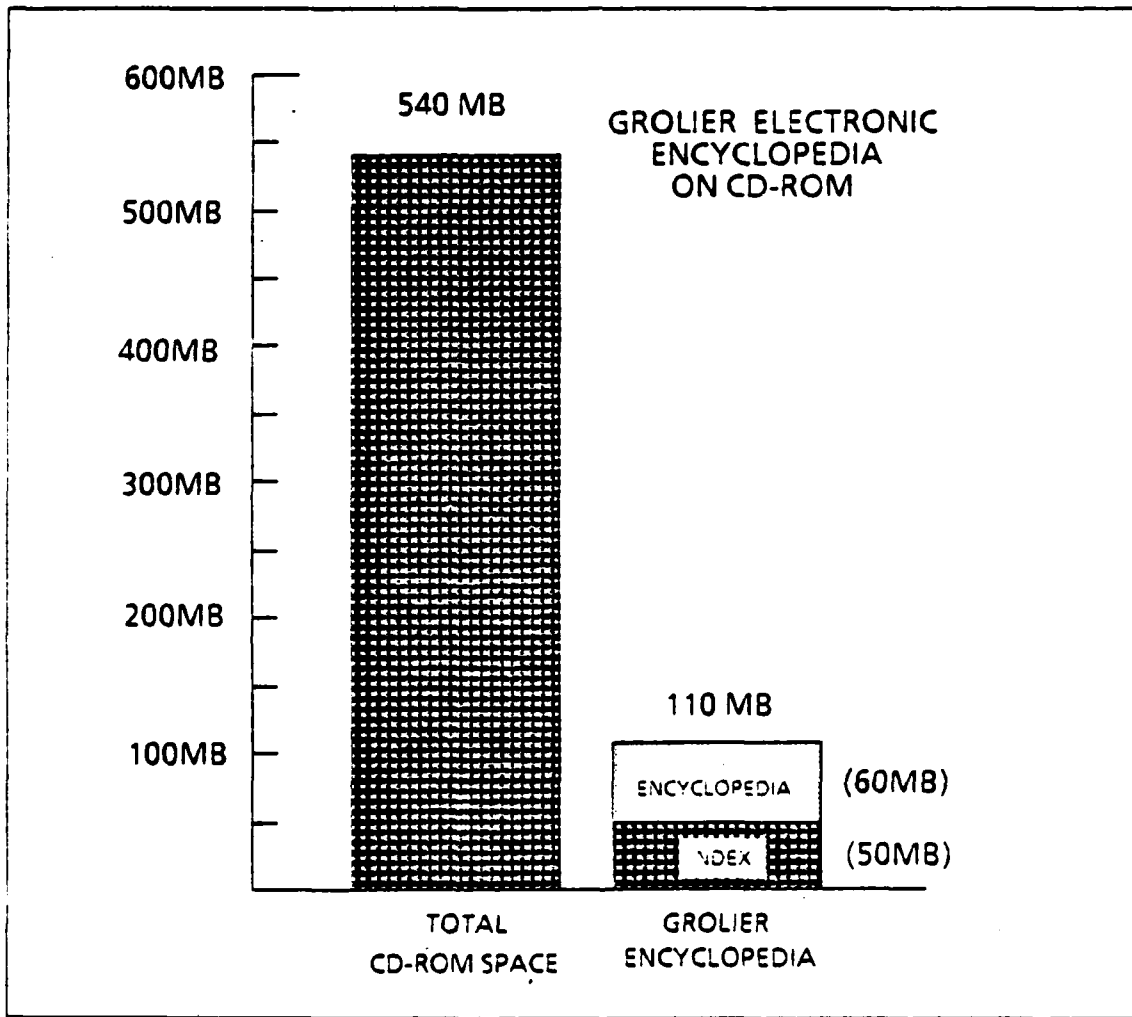

Figure 5.1 CD-ROM Space Utilization--20 Volume Encyclopedia.

An example of the CD-ROM potential for voluminous data storage is illustrated in Figure 5.1 . The Grolier 20 volume Academic American Encyclopedia information system, [Ref. 14: p. 11-16] developed by the KnowledgeSet Corporation of Monterey, CA., was one of the first CD-ROM products available for the general public and is

perhaps the best known CD-ROM application developed to date. Figure 5.1 illustrates the data storage space available on a standard CD-ROM disc and compares this with the bytes used by the indexing and actual encyclopedia page data. This figure clearly demonstrates the quantity of data that can be accommodated on this medium but also demonstrates the indexing overhead required for the word search / cross referencing algorithm employed by this application.

As will be expanded upon in this Chapter, the potential benefits resulting from CD-ROM implementation relating to the Naval Aviation technical documentation environment, identify this medium as the clear choice in optical mass storage alternatives (See Table 4 in section D). These potential benefits are particularly evident in the technical library capacity and relatively data stable technical manual distribution scheme.

The write-once, read-many (WORM) optical medium would be most advantageous in an environment where massive amounts of data are stored once on routine and frequent intervals and then referenced frequently from a local or limited and restricted distributional area. An example of this situation and one where the WORM technologies are being implemented is the U. S. Government's Patent and Trademark Office (GPTO). This system includes a raster scan process which converts all previous and future patent and trademark application submissions into a digitized representation. The resultant digitized data is 'burned' into a 12" optical disk. Several of these 12" inch optical disks are then made available to a workstation environment via a 'juke-box' type of optical mass storage unit. This large-scale mass storage with relatively quick, random access enables trademark / patent lawyers and GPTO personnel to 'pull up' both trademark, patent documentation and litigation paperwork for quick and easy access reviews. Due to the extensive illustrations, graphs and technical data that accompany the patent and trademark application forms combined with the data accumulation attributable to the raster scan representations, the WORM technology was determined to be the most cost effective. The space and environmental constraints related to this specific application are somewhat complex, bulky and environmentally sensitive. This particular set-up would not be amenable to a shipboard or battlefield situation and as such stringent functional specifications related to physical constraints or ruggedization would be required.<sup>8</sup>

---

<sup>8</sup>A militarized optical disc study related to these issues, was initiated by the Naval Air Development Center, Warminster, Pa. with contracts awarded to both Sperry Corp. and Fairchild Industries--see Chapter VII for details.

Another small but significant point to make here is the cost implications attributable to the complexity of the drives related to the WORM's read/write capabilities. The WORM drives require separate read and write laser mechanisms. Additionally, due to the tolerances required for the 'burning' or writing of data and the initial WORM technology limitations relating to these processes, original WORM formatting methods were constrained. This restriction dictated reversion to magnetic media's 5.25" floppy disk format method of concentric circles and constant angular velocity (CAV) or constant RPM.<sup>9</sup> As a result of this design requirement, a considerable amount of data space is 'lost' to disk format and CAV data spacing restrictions. This original WORM formatting method begins to defeat the primary benefit of optical data storage, that of storing massive amounts of data on a relatively small disc.

Still, when compared to present magnetic media data density, expense and maintainability, the WORM method becomes a viable option for certain applications. As the 'laser writing' technologies became more sophisticated, the WORM formatting method advanced to a pre-grooved, spiral track that enabled the manufacturers to approach the track densities of the CD-ROM (16,000 tpi). In fact, the IBM PS/2 optional WORM drive mentioned in the introduction of this section, utilizes the spiral, pre-grooved disk. This additional, proprietary WORM read-write method has only added to the already confusing and complex picture of standardization issues relating to this medium.

The Erasable format is the most iterative and least mature of the three formats being investigated. The technology is not fully developed although several companies have announced limited production of prototype systems scheduled for release in late 1987 or early 1988. Because the erasable medium is in its early stages of research, there is very limited availability of information on system development costs and data storage performance figures. Additionally, due to the inapplicability of this medium to the large scale replication and distribution of non-volatile Naval Aviation technical documentation, a formal feasibility study or prototyping will not be recommended at this stage of development. The erasable optical medium technology will be reviewed in a synopsis manner in section C, however, the emphasis of this preliminary feasibility study will concentrate on the CD-ROM and WORM optical media.

---

<sup>9</sup>The trade-offs comparing the constant angular velocity (CAV) vs. the constant linear velocity (CLV) design decisions are discussed in more detail in section E.

There is an additional optical storage presentation or method that is totally unique in concept, and physical characteristics. This storage medium is the CD-ROM laser card, a format that is in a classification by itself. This type of format may be any of the three media types: read-only, WORM or erasable although the read-only card is the most technically developed. The size and shape of a credit card, the laser card can store approximately 800 type-written pages of data. This alternative is indeed a viable option to the standard optical disc representation and is in fact a major area under investigation by several DOD agencies. The armed forces are considering this option for use as ID cards that will contain the service member's personal and administrative data records including: service, pay, medical, dental, NATOPS flight, etc. The analysis of this format in regards to Naval Aviation technical documentation requires a significantly expanded scope and objective and therefore will not be investigated. In fact, a parallel research project in this area is being conducted by LT. Stephen Frnk in a thesis titled "Optical Memory Cards: A Comparison with Other Current Technologies and Potential Military Applications" [Ref. 15].

## **B. OPTICAL MEDIA HISTORICAL BACKGROUND**

The first experimentation utilizing optical storage was in the early 70's with the majority of the development credit going to the N. V. Philips Corporation, the large Netherlands electronics conglomerate. The Sony Corporation of Japan was also experimenting with optical technologies and developed the first commercially available optical disc. Laservision, a home entertainment, 12" plastic read-only optical disk storing one hour of video on each side, was released by Sony in 1983. This 12" format followed the original standard for optical disks established by Philips in their 1970's experimentations. As the VCR format grabbed the marketplace share, the expensive and somewhat cumbersome laserdisk medium lost ground. A primary reason was the television compatible and interactive taping capabilities of the VCR format.

In November 1982, a second commercial optical disk was also developed for the home entertainment environment. Again, the N. V. Philips and Sony Corporations were the pioneering firms developing this new format and jointly set the standard when they introduced their audio compact-disc. Deciding on a standard formatting method for audio data representation prior to full scale development:

. . . these two companies then prescribed their scheme in a publication known as the Red Book. The Red Book for CD-Audio was quickly accepted and

allowed the market for digitally recorded or re-mastered music on compact discs to grow to major proportions in less than three years--1983-1986. . . . Philips and Sony followed up with a specification for CD-ROM based on the CD-Audio standard. The Yellow Book, as it is known, sets the physical parameters for creation of a CD-Rom disc. [Ref. 16]

This audio-compact disk, a read-only optical disk on which 'musical information' or audio frequencies are encoded digitally, stores up to 74 minutes on one surface of a 12 centimeter (4.72-inch) disk. The sound quality was and still is significantly better than the conventional record systems available and the technology began to catch on.

The CD-ROM, a similar disc medium in which the physical characteristics were standardized by the Yellow Book, was introduced in 1985. An adaptation of the CD-Audio, the CD-ROM was specifically designed for micro computer off-line (peripheral) storage. As stated in the overview section, the CD-ROM is most economically adapted for prerecorded, non-volatile information applications. This medium is particularly suited for the large-scale distribution of: extensive, digital based archival and multi-user data bases such as: reference works, professional directories (medical references or corporate financial profiles) and application software. Because CD-ROM basically uses the same technology as the audio compact disc, this media can take advantage of the success of the audio compact disc. This economy of scale benefits and technological developments enjoyed by the CD-ROM community as a result of the audio compact disc commercial success is a significant factor that must enter into a cost analysis of a formal feasibility study. In fact, since 1983 when the audio compact disc was first introduced, CD player prices have dropped over 50 percent. The CD-ROM environment is enjoying a similar reduction in hardware costs. CD-ROM drives, costing \$1500 to \$2500 when first introduced, have precipitated to the \$500 range.

A significant standardization issue must be broached at this point. As noted, the Yellow Book set the physical parameters of the CD-ROM, however, there are additional concerns regarding structure and formatting standards. The leaders of the CD-ROM community took the Yellow Book standards one step further and addressed the data layer logical level at a conference held at the High Sierra Casino in Stateline, Nevada. The Group established a logical level standard that became to be known as the High Sierra Standard:

Lying above the physical specifications for CD-ROM are two other critical layers: the logical level and the applications level. It is the logical level that the High Sierra Group has addressed.

The logical level addresses how data is represented on the disc. What conventions, such as volumes, files, records, are used and how? How are directories and paths organized? How does the volume and file structure relate to the physical blocks? . . . The High Sierra group's logical level standard proposes a common and known volume, directory, and file structure between all common operating systems. [Ref. 16: p.27]

This structure was developed to accommodate the general characteristics of CD-ROM drives (eg. read-only, large capacity, average transfer times and slow seek times). This enables the CD-ROM disc developers to produce one 'standard' disc and let the operating system architects write the device drivers (retrieval or disc access software) for their individual machine's hardware. This view foresees a proliferating CD-ROM disc market, with new drives, computers and operating systems being able to adapt to this established disc 'data lay-out' as long as the appropriate device driver accompanies the hardware. Although the High Sierra standard is not agreed upon by the entire CD-ROM optical technologies (a fact driven by profit bias in most instances), the very existence of a logical data structure standard places the CD-ROM format lightyears ahead of other storage media.

An alternative to the CD-ROM format but still included in the read-only optical medium is the Optical Read Only Disk (OROM). This disk is designed similar to a magnetic 5.25" floppy disk, utilizing concentric data format and a constant angular velocity (CAV) vice the spiral track and constant linear velocity (CLV) technology employed by the CD-ROM camp. Although the data compression on the OROM is not as advantageous as the CD-ROM, the concentric data lay-out and constant speed design enables specific file positions to be indexed or 'hard sectored' in the pre-stamping process. This formatting scheme permits a faster seek time and data transfer rate and is used where higher I/O performance is required. Although the data retrieval speed implication is a major issue, the OROM format has not matured to a level where comparison to other established optical storage media can be researched by this thesis.

The second type of optical disk, a Write-Once / Read-Many (WORM) disk was first used commercially in 1983. During this development period, several different sizes of discs, types of media composition and formatting methods surfaced. The two most prevalent WORM disk sizes consisted of: 12 " disks that can hold 1000 MB per surface and the 5.25 " disk that can hold about 150MB per side for a total capacity of 300MB. The research companies involved in WORM media development, however, have yet to establish any standardization policies (physical or logical lay-out

standards). This non-standard media environment, a situation in contrast to the CD-ROM's widely accepted Yellow Book and High Sierra formats, has generated independent WORM development that has added to the problem of: several disk sizes, disk construction and composition differences, and widely varying laser writing methods for the WORM technology.

These WORM non-standardized methods create a high risk environment, particularly in the critical formatting methodology, which restricts corporate investment into the WORM systems. The optical read-write (WORM) technologies are still evolving, but this lack of standardization remains a major obstacle that must be considered seriously prior to recommending a continuation to a formal feasibility study. Continued research is recommended for the WORM technology, however, until the standardization issue is resolved, this research effort concludes that the WORM optical media should not be considered for a formal feasibility study at this time. Additionally, the writing process technology will have to continue to improve and the expense related the WORM implementation must be reduced significantly prior to this method being recommended as a viable alternative to the large scale mass storage requirements related to Naval Aviation technical documentation.

### **C. TECHNOLOGY REVIEW - 'NUTS AND BOLTS' PRESENTATION**

#### **1. Read-Only Media**

The 3M Corporation and the Sony Corporation of America, with plants in Menomonie, Wisconsin and Terre Haute, Indiana respectively, are the leading manufacturers of optical discs in the United States. Indicating the burgeoning utilization of both larger optical disks and the similar CD-audio and ROM discs, the annual sales of the 3M plant is in the order of \$8 billion [Ref. 17: p. 34]. Additionally, several other established Corporations along with many new companies are expressing interest into entering this manufacturing market.

The CD-ROM disc turn-around time, an important issue to many data applications, significantly effect the cost of disc preparation.

A price list from March 1987 showed a cost per master of \$4000 with a 20 day turnaround, rising to \$7000 for a three day turnaround and \$11,000 for a one day turnaround. . . . Replication costs vary from \$6 per disc for runs of 5,000 or more to \$30 per disc for runs of less than 100. [Ref. 17: p. 37]

Read-only formats are ideally suited to mass production. This read-only memory (ROM) process is similar to all optical storage disk preparation in that digital data representation is translated into a code or signal which is then 'laser burned' to a laser light sensitive disk. The difference with the ROM media is that this initial laser sensitive disk is transformed into a glass disk master. This data pattern is then embossed or pressed into a poly-carbonate resin (plastic base) surface of the disk by means of a 'stamping' process utilizing a metal 'mother' stamper obtained from the pre-etched or 'burned' glass master. The manufacturing process is similar to that used to press phonograph records, allowing many second generation copies to be pressed from a single pressing master. Due to the stringent tolerances required by the laser focusing requirements, the 'master stamper' is replaced after several thousand pressings.

Before a CD-ROM disc gets to the user, a series of pre-mastering and mastering steps are taken. The CD-ROM replication process includes the following steps:

- Premastering - error correction code (ECC) is calculated along with data header information; receive user data via pre-indexed 1 2" magnetic tape
- Mastering - prepared data is 'cut' or 'burned' onto glass master
- Stamper Production - a metal master is produced from the glass master which in turn is used to produce the metal stamper for disc pressing
- Injection Molding - resin is injected into mold with stamper to obtain disc
- Reflective Layer Coating - transparent discs are coated with an aluminum reflective layer
- Protective layer Coating - ultraviolet curing resin applied to disc

The stamped 'holes' form a series of non-reflective pits on a spiral track. The track is illuminated by a low-power laser and the reflected beam read by a photo-detector. The spiral recording or reading groove is pressed with an extremely sensitive track spacing tolerance so the distance between the grooves is a mere 1.6  $\mu\text{m}$  (micron). To illustrate this sensitivity, the track on a CD-ROM (a 12cm - 4.72 inch, one-side recorded medium) runs continuously for over three miles. This spacing equates to a track pitch of 16,000 tracks per inch (tpi). When compared to the 48tpi of the average dual-density floppy disk, the mass storage advantages relating to space and cost per bit of the CD-ROM become quite obvious. The corresponding linear data density is about 25,000 bits per inch, about 10 times the density of a Winchester hard disk. The 1.6  $\mu\text{m}$  track spacing, a standard established by the original laserdisk of the late 1970's.

became the standard track spacing for the 12cm audio and digital Compact Discs as well as the larger 12" and 14" platters.

Due to the nature of the pressing tolerances involved, the data structures as they are stored on the disk require that extensive error correction coding be appended to the user data before the disk is pressed. The reason for this is two fold. First, as a result of the process used to mass produce the disks there will be a higher incidence of physical error in the reproduction of the data. Secondly, the plastic disks are not as rigid as their magnetic counterparts and consequently are susceptible to a certain amount of warpage and out-of-round errors. These physical errors tend to force the focusing and positioning systems in the drive to work very hard at keeping the laser in the optimum focus and position to read the data as accurately as possible. With such close reading (groove) tolerances, this is not an easy task when the medium is moving both vertically (warpage) and horizontally (out-of-round). The error correction codes (ECC) used in CD-ROM, are a combination of algebraic and interleaving techniques. The error correction program generates eight bytes of ECC for each 24 bytes of user data. This means that for a 12cm CD-ROM there is about 185MB of ECC in addition to the 560MB of user data making the actual capacity of the disk 745MB. That's still 560MB of user data. Because of this extensive error correction coding optical media can boast around one error per quadrillion bits (1 + 15 zeros)

In review, the ROM optical disks' are replicated via a pressing process and have an impressive capacity: one CD ROM can contain as much as 560 Megabytes of user data; a 12" disk can hold 1 Gigabyte of information and a 14" platter can handle as much as 10 GB of data. The aforementioned lasercard can now store up to 2.2 MB on the credit card sized medium.

## 2. Write-Once/Read-Many (WORM)

The Write-Once/Read-Many (WORM) systems [Ref. 18: pp. A-1 - A-3], require two laser 'heads' to perform the separate processes of reading or writing. A higher power laser is used in the writing or 'burning' laser head to bubble, deform or ablate a thin film of a specially developed, light sensitive, precious-metal alloy embossed to a glass substrate on the disk. A second, lower powered laser is directed onto a predetermined grooved path and the difference in the reflection pattern is interpreted and converted into binary representation. Data is encoded onto a 14.500 track disk (5.25" format) separated by 1.8 microns. There are 32 sectors per track with 360 bytes per sector. The sector layout includes 256 bytes of 'user' data, 32 bytes of

error correction coding (ECC), and 72 bytes of header information. The header field provides a timing sync pattern, track/sector address fields and a status flag field which is utilized to identify bad formatted sectors or to mark those sectors that have been written to prevent overwriting. The disk's optically sensitive coating is composed of:

... a thin film of either tellurium alloy or gold/platinum alloy. A laser beam creates a permanent deformation on the disktrack as it rotates. This deformation is detected as a difference in light reflection as the thin film's reflectivity is about 30%, while the pit reflectivity is about 5%. An optically clear sealed sandwich, made of polymethyl methacrylate for commercial grade disks or of polycarbonate or glass for military grade, protects the substrate. This sandwich creates an airspace between the substrate and the outer layer, enabling gases to disperse as the pits are formed. [Ref. 19: p. 40]

As alluded to in both the introduction and background section of this Chapter, the WORM media disks are available in several different sizes and formatting schemes. The different disk characteristics include: 3.5", 5.25", 8", 12" or 14" diameters, usually two sided recording surfaces and either a concentric or spiral tracking groove that is embossed into the polymer surface during manufacture. Some disks are optically pre-formatted with a hard-sectored environment in order to enjoy the benefits of a constant angular velocity format. As previously discussed, (and expanded upon in greater detail in section E), the CAV allows faster random access but results in reduced data densities when compared to the CLV data transfer method employed by the read-only media (ie. CD-ROM).

As stated, the WORM disks can be 'pre-grooved' or formatted during the manufacturing process or they can be of the 'soft-sectored' format. This 'soft-sectored' format requires a groove track guidance process for alignment that must be applied during the writing phase. The alignment pits, called servo tracking nibbles (SNIBS), consist of two pits embedded along each track at four byte intervals. The SNIBS are used as the tracking pits and eliminate the need for pregrooved disks. The SNIBS ability to detect storage medium flaws decrease the error rate to one in 100,000. The SNIBS in combination with the extensive Reed-Solomon error correction algorithm improve this error rate to one in 1,000,000,000,000. A thumbnail sketch of this soft-sectored and groove format difference recently published in the Government Computer News states:

Instead of grooves, a WORM disk uses an "embedded servo", a more reliable way to ensure accurate laser head-to-track alignment. When formatting a

WORM disk, a laser burns a pair of pits along both sides of the track to act like guard rails on a narrow road. The servo path guides the read write head between the pits with great precision, assuring proper head-to-track alignment and a reliable read. The combination of an embedded servo and error correction codes allows WORM optical drives to spin faster than CD-ROMS, giving WORM drives a higher data transfer rate between the disk and the PC. [Ref. 20: p. 68]

Once data is written onto the disk it cannot be erased or altered. In some applications (eg. real-time, permanent and/or future archival records or financial transactions where an audit trail may be required), this feature could be a great benefit. In other applications, for example inventory processing, if an error is found, the question of rewriting the entire file or appending the correct entry via an alternate indexing scheme becomes a critical issue. This issue becomes pertinent any time sequential, non-alterable data is the storage method. Tailoring this technology to the appropriate application is the most important consideration and not just a cost benefit comparison. Even though this medium can store five times as much data as an equivalently costed winchester disk, a WORM application would not be an effective or efficient mass storage alternative for a dynamic database.

### 3. Eraseable Formats

The demand for applying the optical storage benefits to an eraseable or alterable disk format has driven the research environment of this media into a frenzy.

The quest for the new, eraseable optical disk technologies has already led companies around the world to invest "several hundred million dollars" . . . In the race to the Market, 3M appears to be leading, however, Philips, Eastman Kodak Co. International Business Machines Corp., Sony Corp., and others have exhibited prototypes or publicized research.

A magneto-optical hybrid process . . . a product, for which the 3M company is completing a pilot project, can be written on and erased repeatedly, more than 200,000 times, but many industry analysts say the whole reading and writing process is now too slow for many computer uses. [Ref. 21: p. 19]

There are currently three popular technologies, of which there are several variations: Magneto-optical, Phase Change and Polymer Dyes. Currently magneto-optical and phase change techniques are getting the most attention [Ref. 22: pp. 30-33].

#### *a. Magneto-optical*

In the magneto-optical disk a write is accomplished by subjecting the medium to a low intensity magnetic field and then focusing the write laser on a 2um area of the surface. The magnetic field itself is not of sufficient strength to affect the

medium until it is heated by the laser to about 200 deg. C, the Curie point. At that temperature the magnetic domains in the medium align themselves with the magnetic field (a reversal) and retain that alignment after cooling. To read the disk a lower power laser is used to illuminate the disk surface and two techniques are used to interpret the reversed magnetic domains. The most popular, the Faraday Effect, measures the change in polarity or rotation of the laser beam as it passes through the medium. The other technique is the Kerr Effect and it measures the change in polarity of a beam reflected off the surface of the medium. To erase, the area is reheated by the laser while the field coil presents a reversed field, realigning the domain to its original polarity. The implications of data being effected by magnetic fields or electric magnetic pulses (EMP) need to be addressed.

*b. Phase Change*

Phase change technology takes advantage of the ability of certain rare earths to simultaneously exist in crystalline and amorphous or non-crystalline states. To write, the high power write laser heats the surface of the medium to a high temperature for a very short period of time, typically less than 100ns. The medium cools rapidly to an amorphous state. The amorphous areas have a lower reflectivity than their crystalline counterparts and are read in much the same way as read-only technology. Erasure only requires that the surface of the medium be heated again for a much longer period (1-5ms) and allowed to cool more slowly.

*c. Polymer Dye*

Polymer dye techniques are based on a color change principle. The write/erase process is essentially the same as the phase change technique. The write or higher powered laser head directs a beam onto a light sensitive track of an alloy of silver and zinc. This metal combination assumes different phases with different crystalline structures at high and low temperatures or in other words, changes color. Instead of using the differences in light reflectivity from the lower laser powered read head, the differences in color can be distinguished and transformed into binary representation. Organic polymer dyes are very stable, inexpensive to manufacture and apply to the substrate material. The color change can be effected by a relatively low-power laser further reducing system costs.

To review the erasable media options--in contrast to magnetic media storage, the magneto-optical disk drives cannot 'burn' data one bit at a time. The MO method must erase an entire track then rewrite corrected data over this 'reformatted' area.

Both the Phase Change and Polymer Dye techniques do have this capability, however, the durability and unstable properties of the metal alloys used in these processes are significant drawbacks and are still being investigated.

In a summary offered by a Naval Air Development Center (NAVAIRDEVCCEN) sponsored study conducted by the Sperry Corporation [Ref. 18: p. 4-4], the research concluded:

. . . the read-write-erase technology is not ready yet, and Sperry feels that two to four years development will be required before this technology is ready for the commercial market. . . . The current status of each of these approaches is stated briefly below:

1. Magneto-Optical is the most mature technology. It has excellent data storage characteristics, however, there is no overwrite capability.
2. Phase Change also has the requisite qualifications for high density storage, however, PC suffers some read cycle degradation and the media life is only three years.
3. Dye:Polymers are the newest and most exciting erasable technology. It offers high performance and overwrite capability. There are questions, however, as to its availability and read cycle degradations.

Extensive research continues in the field of erasable optical media. Experimentations in the production of a single read/write laser head and efforts into the development of hybrid optical drive systems--one drive capable of reading and writing the ROM, WORM and erasable formats, are being conducted. The erasable media storage method deserves continued DOD sponsored research, however, as previously stated, significant technological development and standardization will have to be achieved prior to implementing full scale feasibility studies.

To conclude this optical media technological review section, it becomes quite clear that even with limited knowledge of the Navy's mission environment and a cursory review of this paper, the CD-ROM format surfaces as the clear publication medium alternative for Naval Aviation technical documentation. A graphic display illustrating the optical media's performance by depicting CD-ROM and WORM general characteristics and data capacity comparisons to existing media are presented. Table 2 [Refs. 18,23: pp. B-1,28], offers a quick technical review of pertinent media characteristics and formatting methods of both the CD-ROM discs and WORM disks. Table 3 [Ref. 23: p. 24] illustrates the storage capacities of the CD-ROM and WORM formats as compared to more familiar storage media.

TABLE 2  
CD-ROM DISC AND WORM DISK CHARACTERISTICS

CD-ROM CHARACTERISTICS:

- SIZE: 4.72 INCHES
- STORAGE CAPACITY: UP TO 600 MB
- DATA TRANSFER RATE: 1.5 MB/SEC
- ROTATION SPEED: 200 RPM (OUTER TRACKS)  
500 RPM (INNER TRACKS)
- ACCESS TIME: APPROX. 0.5 - 1 SECONDS
- ROTATIONAL LATENCY: 60 - 130 MILLISECONDS
- TRACK CHARACTERISTICS: CONSTANT LINEAR VELOCITY (CLV)
- TRACK LENGTH: 3 MILES (READING STARTS AT THE INNER TRACK)
- AVERAGE PIT SIZE: 1 MICRON
- AVERAGE TRACK SEPARATION: 1.6 MICRONS
- INFORMATION RECORDING: ONE-SIDED ONLY

WORM CHARACTERISTICS:

- SIZES: 3.25", 5.25", 8", 12", 14"
- STORAGE CAPACITY: 300MB -- 5.25" ; 3.6 GB -- 12"

-5.25" WORM DISK (CAV):

- DATA TRANSFER RATE: 5 MB/SEC
- ROTATION SPEED: 1800 RPM (CAV)
- ACCESS TIME: AVE. SEEK APPROX. 0.02 SECONDS
- ROTATIONAL LATENCY: 16.7 MILLISECONDS
- TRACK CHARACTERISTICS: TRACKS:14,500; SECTORS:32/TRACK  
512 BYTES/SECTOR
- AVERAGE PIT SIZE: 1 MICRON
- AVERAGE TRACK SEPARATION: 1.6 MICRONS
- INFORMATION RECORDING: TWO-SIDED

TABLE 3  
CD-ROM AND WORM (5.25" DISK)  
CAPACITY COMPARATIVE EQUIVALENTS

**A SINGLE CD-ROM CAN HOLD THE SAME INFORMATION HELD BY:**

- 270,000 PAGES OF TEXT OR,
- 20,000 PAGES OF IMAGES SCANNED AT 300 x300 DPI OR,
- 10,000 PAGES COMPRISED OF 1/2 TEXT AND 1/2 GRAPHICS OR,
- 1,500 5 1/4" FLOPPY DISKS OR,
- 1,200 MICROFICHE CARDS OR,
- 1,104 HOURS (46 DAYS) OF DATA TRANSMISSION AT 1200 BAUD OR,
- 27 20-MB WINCHESTER DISKS OR,
- 10 STANDARD 1/2 ", 9-TRACK TAPES OR,
- 1 HOUR OF FULL MOTION, FULL SCREEN, FULL COLOR VIDEO.

**A SINGLE WORM (5.25") CAN HOLD THE SAME INFORMATION HELD BY:**

- 100,000 PAGES OF TEXT OR,
- 8,000 PAGES OF IMAGES SCANNED AT 300 x300 DPI OR,
- 3,500 PAGES COMPRISED OF 1/2 TEXT AND 1/2 GRAPHICS OR,
- 600 5 1/4" FLOPPY DISKS OR,
- 450 MICROFICHE CARDS OR,
- 408 HOURS (17 DAYS) OF DATA TRANSMISSION AT 1200 BAUD OR,
- 10 20-MB WINCHESTER DISKS OR,
- 4 STANDARD 1/2 ", 9-TRACK TAPES OR,.

#### **D. ADVANTAGES/DISADVANTAGES OF OPTICAL MEDIA**

The most important aspect in determining any alternative related to the Naval Aviation technical documentation methodology is the overall effectiveness of the medium vice cost benefit analysis only. The unsuccessful implementation of the MIARS program aptly illustrates this concept. The optical media alternatives and distribution schemes related to this Naval environment, heavily favor the CD-ROM format. As noted, the technology benefits obtained from the CD-audio successes coupled with the established physical media and logical data layout standards, weighed heavily into the recommendation of the CD-ROM alternative.

Besides the obvious benefits of space savings and environmental considerations (data durability), the distribution advantages relating to both initial and revisional documentation packages, clearly identify the CD-ROM storage medium as the obvious choice for digitized, technical documentation representation. The implications of distributing or mailing four or five manuals of an original issue or revision of a major technical work package utilizing a four ounce CD-ROM disc vice a twenty pound carton containing the paper-based manuals, needs no exemplification. The distributional benefits of the CD-ROM medium, a graphic comparison and a more detailed analysis of the weight/cost benefits will be offered in section F, depicted in Figure 5.3 and analyzed in Appendix C.

The administrative accountability of a CD-ROM distribution methodology, when verifying incorporation of technical manual changes or hazard to flight rapid action maintenance engineering changes, would be considerably more effective and much easier. Each new or updated CD-ROM 'version' could employ some disc distinguishing method, such as disc color coding. This would enable an ADMAT inspecting officer or technical manual librarian to conduct technical documentation checks in a fraction of the time now spent checking the different types of documentation corrections. Additionally, the potential applications and advantages of the Compact Disc-Interactive (CD-I) and Digital Video Interactive (DVI) formats, both real-time audio-visual media that utilize the CD disc drive technology, have added benefit for CD-ROM implementation. These developing formats are particularly advantageous in the practical training and maintenance 'action' demonstration regimes from the basic 'how to' presentation through complex, procedural technical applications. Table 4 [Ref. 24: p. 48] concisely lists the advantages associated with the CD-ROM medium. Table 5 [Ref. 24: p. 51] depicts the disadvantages of this medium.

TABLE 4  
CD-ROM STORAGE MEDIUM ADVANTAGES

**ADVANTAGES**

- **PERMANENT/DURABLE:** It is an excellent archival medium (currently Sony disks are guaranteed for 50 years.) Also very rugged and able to withstand adverse weather and handling conditions.
- **NON-VOLITATILE:** No loss of altering of data during power failure or surges.
- **LOW COST:** The 'per MB' cost of data is less than any storage medium.
- **EXTREMELY PORTABLE:** The media is removeable and offers portability of data. - Disc maintenance extremely easy i.e. soap and water wash annually.
- **SECURITY:** Physical control can be maintained easily and thus large quantities of sensitive data can be controlled. Also, the possibility exists to manufacture the disk out of glass instead of polycarbonate material and thus, for military purposes emergency destruction could be easily accomplished.
- **SMALL VOLUME/WEIGHT:** Easily carried, mailed etc, at a very low expense.
- **UNALTERABLE:** Media is Read Only Memory (ROM) and as such, it is extremely useful for audit trails in a legal / financial environment ; magnetic media have not been allowed as evidence due to media alterability .
- **ENORMOUS DATA STORAGE CAPABILITY:** Up to 600 MB of data on a single side of a single disk which is only 4.72 inches in diameter.
- **USER FAMILIARITY:** It is simply another PC peripheral that, to the user, looks just like a read only MS-DOS etc. disk. Also, the average user has had experience with the same physical disk in the CD-Audio environment and therefore feels more comfortable with it all ready.
- **BACKUP IS ELIMINATED:** There is no need to backup the disk because it is ROM. For safety sake, multiply copies can be ordered at the time of disk pressing and stored in separate locations.
- **ELECTRO-MAGNETIC PULSE (EMP) HAS NO EFFECT:** This is not a magnetic media and therefore any sort of electro-magnetic energy has no effect on it.
- **NO HEAD-CRASHES:** The read-device is optical and does not contact the disk in any way, therefore, head-crashes are virtually eliminated.
- **MULTI-MEDIA POTENTIAL:** The new CD-I and DVI multi-media, interactive capabilities have tremendous implications for a training/how-to application.
- **EXTREMELY LOW ERROR RATES:** Due to the extensive ECC available from enormous storage areas, error rate = 1 error in a quadrillion bits (1 + 15 zeros).

TABLE 5  
CD-ROM STORAGE MEDIUM DISADVANTAGES

DISADVANTAGES

- **READ ONLY:** This feature, while a benefit to some is a hindrance to others desiring to alter their data.
- **INITIAL COSTS FOR ADDITIONAL HARDWARE:** Although this is true of any new system, it is viewed by many as a disadvantage when compared against the all ready sunk costs of the presently installed system.
- **SLOW ACCESS SPEEDS:** The average time to retrieve data, when compared to hard disk etc. is much longer.
- **DATA PREPARATION COSTS:** Indexing ,retrieval software, and revision replication costs for dynamic (new weapon systems) databases may not be as economical as alternative media not requiring as extensive data preparation.

The WORM medium cannot be totally discounted as an optical storage alternative in the Naval Aviation technical documentation scheme. In fact, with continued technological breakthroughs such as hybrid optical read-write systems, this media may well be the appropriate design choice for certain storage applications. There are several applications the present WORM technology would not only support but would be advantageous. Local, archival back-up storage applications such as daily but stable data record keeping environments similar to an in-house squadron flight hour or aircraft component time accountability system. This data would initially be entered on magnetic media due to daily transaction, transcribing and general accounting errors. The flight and component times would be verified and then stored or 'burned' to the WORM back-up storage system. The WORM audit trail characteristic would be advantageous to the storing of completed maintenance actions once the data's been verified as described above. This maintenance historical record identifying: supply usage, part numbers, maintenance performed, mechanics and other pertinent data, could be used to reconstruct a maintenance action profile in order to assign responsibility or culpability to the appropriate individual, area in the event of an aircraft mishap.

Table 6 offers a concise overview of the advantages and disadvantages of the WORM disk format.

TABLE 6  
WORM STORAGE MEDIUM ADVANTAGES AND DISADVANTAGES

### ADVANTAGES

- **MASSIVE DATA STORAGE CAPABILITY:** Similar storage potential of CD-ROM; approx. 1/3 capacity of similar sized disk.
- **REAL-TIME DATA STORAGE:** Data stored at 'terminal', no data preparation or replication costs, immediate availability /access to stored data.
- **LOCAL STORAGE APPLICATIONS:** In-house data control, alleviates security issues of data preparation and mastering at external replication site.
- **ARCHIVAL BACK-UP :** stabilized/indexed magnetic data to WORM back-up
- **AUDIT TRAIL BENEFITS:** investigate transactions and historical actions.
- **ENVIRONMENT TOLERANCES:** Better environmental tolerance/durability than magnetic media - less than CD-ROM - (EMP, headcrashes, dust, ).
- **SMALLER USER BASE REQUIREMENT:** Cost benefit trade-off requires smaller scale data base distribution effort vs. CD-ROM disc replication costs, two to twenty 'users' in a local area network (LAN) could justify WORM usage.
- **LOW COST:** Low cost / bit, more expensive than CD-ROM due to writing tolerances and WORM disk composition, but much less than magnetic formats.
- **FASTER RANDOM ACCESS (CAV):** Constant RPM and hard-sectored disks enable faster data access , faster with pre-indexed data prep.

### DISADVANTAGES

- **LASER HEAD COMPLEXITIES:** Two laser heads required for read / write operations - ruggedization problems with exacting tolerances of WORM..
- **DISK REVISION OR ERROR CORRECTION ISSUES:** Inability to write over a mistake or to make minor revisions/updates in the 'burned' read-only data.
- **LACK OF PHYSICAL OR LOGICAL STANDARDS:** WORM industry proprietary concerns have precluded a disk medium physical or data layout standard.
- **COMPLEX INDEXING / SEQUENTIAL WRITES:** Real-time data goes to disk sequentially, efficient indexing for logical data access must be done prior or after 'burning' process on a second WORM disk.
- **AVERAGE ACCESS TIME:** With poor indexing or data layout (resulting from sequential writes), access times suffer compared to erasable media that can shift data blocks to accommodate logical addressing.
- **DISK COSTS AND ALLOY SUBSTRATE STABILITY:** Long term life-cycle and WORM medium applications in extreme military environment not fully tested.

## E. COMPARISON OF OPTICAL AND MAGNETIC TECHNOLOGIES

When comparing magnetic and optical media there are several aspects to consider: Capacities, access/transfer speeds, physical storage requirements and cost. Cost comparisons relating to Naval Aviation technical publication and distribution will be discussed in section F.

Clearly, the biggest advantage to optical storage is capacity. Some of this capacity was alluded to earlier and illustrated with the capacity equivalent comparison summary offered in Table 3. Further illustrating the density benefits of the optical media compared to the magnetic technologies, several additional comparisons are presented. A single 14" optical disk can store the same amount of information as 50 ten and a half inch reel, nine-track tapes (6250 bpi). The same disk has about ten times the bit density of IBM's top-of-the-line 3080 disk drive. Relating this density to a more familiar paper and floppy disk comparison, a standard (5.25") 400K floppy disk can store the equivalent of roughly 75 pages of text. A 10MB Winchester hard disk stores about 1900 pages of text. A 12", 1 gigabyte (1GB) optical disk stores about 190,000 pages of the same text. An increase factor of 2,500 over the floppy and 100 over the hard disk.

File access and transfer speeds are another story. A large, high-speed hard disk drive can access data in the 8-50ms range and transfer that data at rates of 8-40 Megabytes per second. Access times for a large read-only optical disk are typically 10 to 300ms due to file organization which is more or less sequential. This is a result of a design decision to use a Constant Linear Velocity (CLV) format vice the Constant Angular Velocity (CAV) format currently in use with large high-speed magnetic disks. Because of the fixed sector size, i.e. 256 bytes, the CAV format results in bits being farther apart toward the outer edge of the disk than toward the center. This can be considered wasted space. The CLV format uses a variable-speed spindle motor and a constant sector length which remains under the read head a constant period of time vice the read head reading different sized sectors for a constant period of time. This is accomplished through the spiral track and variable speed (RPM) drive. The CLV approach results in considerably higher densities and actual faster data transfer times IF the data is sequentially stored and accessed. This faster data transfer rate is the result of the average CLV RPM being about 40% faster than the CAV's constant RPM. Most random accessed data is not stored sequentially, therefore to search for a particular record the head must "skip" ahead or back on the disk and then re-sync to

the disk to read. After reading a few sector headers to orient itself, the head again skips ahead until it gets close enough to the desired sector to "read into it". This searching is where the trade off occurs, however, as this constant head movement and disk speed re-syncing causes the seek times to increase significantly. This 'seek time' or head movement is the more critical or time consuming process of data transfer, therefore the CLV method can be slower than the CAV method of constant RPM and head movement. Because of this variable speed phenomenon, the data transfer rates of CLV methods are given in average speeds as the rate depends upon data position on the disk.

As stated, the CAV method is used for high performance input/output (I/O) requirements, and the CLV format is utilized when the added data densities are more beneficial than I/O operations or data is routinely stored and retrieved in a sequential manner. A comparison of the data transfer rates between the two methods using familiar examples of disk drives manufactured by the same company should demonstrate performance differences. Using the Apple 3.5" and 5.25" drives owner's manual [Ref. 25], we find that the the 3.5" drive (using the CLV method) transfers data at a rate of 489.6 KB/sec from a disc with a formatted data capacity of 819.2 KB per disk or 409.6 per surface at a disk rotational speed of 394 - 590 RPM. An Apple 5.25" drive has a transfer rate of 250 KB/sec from a disk formatted for a 143 KB capacity--single sided, with a disk rotational speed of 299 RPM. An important point to make of this comparison is that although the speed at which the 5.25", CAV transfers data appears to be slower, the overall percentage of disk stored data is transferred faster because of the faster seek times associated with the CAV methodology.

A synopsis of the CAV vs CLV design trade-offs was published in a militarized optical disk study [Ref. 26: p. 7-2] conducted by the Naval Air Development Center. This report states:

. . .Concentric track evolved largely from magnetic disk technology. It makes use of concentric, circular tracks evenly spaced radially across the disk. Concentric advantages are:

- Compatible with current disk operating systems.
- More conducive to disk-like applications both logically and in data access.
- Does not require continual "kick-back" of tracking actuator to dwell on a track
- Generally more desirable for high-performance systems.

Spiral track evolved largely from video disks which was a low-performance constant linear spin velocity technology. Its advantages are:

- More conducive to tape-like or streaming applications.
- Compatible with CD-ROM and assumably OROM.
- Easier to make masters than concentric-track (except for some current difficulties in providing preformatted servo marks and data)

Storage and handling considerations favor the optical media to a great extent. As previously mentioned and listed in Tables 3, 4 and 6, the data durability, storage ease related to space and maintenance and handling/portability benefits far outweigh the present magnetic storage systems. Coupled with the extraordinary benefits gained from massive data storage on such a small medium, these handling considerations are extremely critical with severe space restrictions and extreme environmental conditions found on a shipboard environment. The limited maintenance, environmental tolerances and general 'sailor proof' parameters of the optical media were major factors in deciding in favor of the CD-ROM medium as the optical media alternative selected for Naval Aviation technical documentation representation. Read-only media are expected to be relatively permanent due to the stability of the medium and the fact that there is no friction involved in the read process. The disks are light, thin and very durable so storage would only require protection from scratches, excessive heat and/or pressure. Some question of permanence still exists for the WORM and erasable media because of stability and wear problems associated with the exotic materials used in those products. Most companies, however, are willing to guarantee a 10-20 year life-span for their erasable products.

There is one final problem that seems to plague every new technology and is demonstrated in the computer hardware data transfer interface--standardization. The magnetic media more or less settled on the two micro Standards--5.25" CAV (IBM and clones) and the 3.5" CLV (Apple, Amiga, Atari). The optical industry sees new companies entering the field every day with each wanting its own standard to be the industry standard. True standardization would come in the form of disk size, write/erase technique and interfaces. Right now the read-only disk seems to have settled into 12cm, 12 and 14 inch sizes while the WORM and erasable firms are still fighting over several sizes and different formatting methods.

In conclusion, the optical media alternatives offer significant benefits as depicted in Tables 4 and 6. Drawbacks remain, however, such as the access data transfer rates,

unpredictable life-span of the new erasable medium and of course the standardization issue. The potential benefits related to the Naval Aviation technical documentation environment in regards to data transportability, durability and distribution cost savings require a formal feasibility study to compare and analyze the trade-offs. A preliminary general characteristics representation and comparison between common magnetic media devices with those of the CD-ROM and 5.25" WORM storage media is depicted in Table 7 [Refs. 24,27,18: pp. 64,47-48,B-1].

TABLE 7  
OPTICAL VS MAGNETIC STORAGE DEVICE COMPARISON

MEDIA	Small Winches t.Disk	Large Optical ROM	5.25" Floppy Disk	1/2 " Magnetic	Large Winches t.Disk	CD-ROM	5.25 " WORM Disk
Media Cost (\$)	N/A	15-30	1-5	10-20	N/A	10-20	95-150
Drive Cost (\$)	500-3,000	7,000-100,000	200-1,500	3,000-15,000	10,000-250,000	500-2,500	5,000-15,000
Capacity (in MB)	5-50	1,000-4,000	0.36-1.20	30-300	50-4,000	540-680	200-300
Cost per MB (\$)	63.63	21.41	1093.59	54.64	39.51	2.48	17.40
Media Size (in.)	5.25	12.00	5.25	10.50 REEL	14.00	4.72	5.25
Access Time (sec)	.03-.30	.03-.40	.003-.05	1-40	.01-.08	.5-1.5	.01-.5
Density (bits/in.)	15,000	35,000	10,000	6,250	15,000	35,000	23,000
Data Rate (KB/sec)	5,000-10,000	8,000-40,000	30-1,000	100-10,000	8,000-40,000	500-1,200	500-4,000

## F. OPTICAL MEDIA PUBLICATION METHODOLOGIES

As a result of the CALS<sup>10</sup> directive and OPNAV Notice 5440--the Navy's CALS implementation responsibility assignment directive, the most difficult milestone, the decision to digitize all future and present weapon system support documentation, has been accomplished. Prior to commencing any feasibility study relating to alternative Naval Aviation documentation representation, this digitization commitment had to be made. Because of the less than outstanding results of previously enacted Naval data automation schemes, there are camps throughout the service that support the idea that any alternative to the 'reliable paper-based manual' just won't work. This mentality must be overcome prior to realizing an appropriate digital data-based documentation system implementation.

To stress a point expressed on several occasions throughout this paper, the key to successful data automation is the development of a system that is designed with the 'typical' sailor and his/her 'typical' environment in mind. Because of the Navy's incredibly diverse and inherently dynamic mission requirements, this is not an easy task.

There are several issues related to the Naval Aviation publication environment that will be addressed in this section and specifically how optical storage media alternatives (the CD-ROM and WORM in this research) compete in the data representation / automation field. The issues that will be briefly analyzed include: present paper-based technical documentation conversion, environmental concerns, data durability, space and weight costs, hardware investment, software requirements, and initial issue and revision distribution implications.

The federal government is a massive storehouse of information that needs converting to digital form.

According to Defense Department officials, DOD alone has over 200 million engineering drawings it wants scanned or digitized. On the civilian side, the Patent and Trademark Office is currently digitizing the recorded ingenuity of the nation by scanning the entire U.S. patent file of some 4.5 million documents,<sup>11</sup> each of which averages eight pages. [Ref. 28: p. 26]

The implications of converting such a large data base, with many very old and complex images 'drawn' on different sized pages, boggle any data conversion project managers' mind.

---

<sup>10</sup>see CALS initiative Chapter III section A.

<sup>11</sup>see WORM application to GPTO conversion Chapter V section A.

There are basically two options in converting this archival and future data (if submitted in a non-digitized format): re-keying text and re-drawing the engineering diagrams on a CAD/CAM system OR by scanning the original documents then translating this representation in a binary code. This research, in cooperation with the Plantir Data Corporation, attempted to approximate the cost differences of re-keying text and applying CAD/CAM graphics for drawings versus a total scan option. The manuals used: a volume of an H-46 Helicopter Maintenance Information Manual Series--used for comparison of engineering drawings and plate foldout pages; and an H-46 Helicopter Naval Aviation Training and Operations Standardization Manual (NATOPS)--representing a mostly text-based manual, are quite representative of the majority of manuals utilized in the Naval Aviation technical manual environment. The results of this study are depicted in Appendix A.

Scanning technology has come a long way since the first experiments of the late 1800's. Optical Character Recognition (OCR) was the earliest scanning technique. The scanning tolerances were quite severe in that special typesetting, fonts, spaces, and even paper were required for the conversion of text (letters or numbers only) to binary code. The OCR technologies have become much more sophisticated and flexible as characters can now be deciphered through software applications that recognize shapes of characters of different fonts, typefaces and even of proportional spaced data. As advanced as the OCR technology has become, it still cannot interpret an engineering illustration and the quality assurance concerns of converting massive, poor image manuals precludes this method of conversion of the Naval Aviation archival documentation.

A second method of scanning data is referred to as image scanning. There are two basic methods of image scanning: raster scan and vector scan. The raster scan method scans and stores an entire document by dots or pixels--this representation is called bit-mapping. This representation is recorded by light scanning and reflecting or not reflecting off of the image's ink or similar reflective interpretation. The vector scanning method is accomplished in the drawing development or database formulation stage. A drawing is either 'traced' onto a CAD/CAM graphic interpretation system or specific geometric representations of a design are rendered as coordination points referenced around key 'anchor' points. These points can then extrapolated using sophisticated graphic processing algorithms to imply shapes, lines, etc. to electronically reproduce and manipulate the desired drawing. The 'drawing manipulation' this technology affords includes rotation, magnification, sectioning and similar processes.

At issue here with the archival Naval Aviation technical documentation database is the personnel intensive requirement of 'tracing' existing engineering drawings via a CAD/CAM system to a vector format. In truth, many of the existing drawings are never or at best very seldom used, therefore the cost benefit of such a labor and hardware intensive application is not worthwhile. Another alternative is to utilize the raster scan method. Due to the age and quality of many of the archival engineering drawings and the different sized pages/foldouts they entail, this option also would require a rather labor intensive quality assurance 'clean up' process to clear stray marks and ensure proper transfer of images.

Although the raster scan method may be 'easier' to translate largescale, archival databases, a major trade-off with the raster scan process is the amount of data capacity required to store full pages of blank areas included in engineering drawings. As an example of comparison between raster and vector scan, a typewritten page consisting of 2,000 characters would require 2K of data space if converted to ASCII, but if raster scanned, this same page would take up 40K of storage. The raster scanned images that are processed via compaction algorithms reduce the data storage requirements but still do not approach the memory space savings of the vector representation method. The compaction algorithms are constantly improving their technology but a standardization policy has yet to be established.

There are experimentations being conducted to transform raster scanned data into the vector format both to memory save storage space and to enable graphic representation processing or manipulation--i.e., rotation or magnification. The technologies have not quite reached the sophistication level where the final product is of a quality amenable to a CAD/CAM environment. This situation is graphically depicted in Appendix B which illustrates a study conducted by the Sundstrand Corporation in conjunction with their Boeing 757 CD-ROM maintenance manual development project.

In conclusion, the massive data capacities offered by optical media alternatives, the excessive storage requirements the raster scan method utilizes to represent engineering illustrations are more realistic. The key to any technical documentation digitization program involves initial development on a CAD/CAM vector trace system. Additional benefits would be realized if textural labels or text descriptions included with graphical illustrations could be represented by ASCII code. This developing technology, where text labels are 'connected' to illustrations and vice versa is a process

known as text 'hot linking'. This concept is also very important in the indexing process, correlating text that references one or many associated diagrams or illustrations. Additionally, the scanning process related to non-standard drawings that include fold-out pages, is rapidly being developed by the the scanning industry. The industry is working on a 'tiling' scheme that breaks the drawing into predetermined blocks. Again, the standardization issue of how to break-up and compact the 'tiles' is holding up widespread use of this method.

The remaining issues relating to the NAVAIR technical documentation regime are a little less encompassing as they are mostly a review of the issues or benefits already identified in this paper. First, to generalize the Navy's Aviation publication environment functional specifications: the documentation medium must be environmentally tolerant--applications from the flight deck to tropic and arctic air stations must be met, dessert applications and areas where extensive dust and dirt are the norm must be considered. Data durability; a medium capable of deploying in a cruise box that may be doused, depressurized, exposed to every extreme of weather and roughhandling. It becomes quite clear that the CD-ROM advantages (see Table 4 to review the durability and versatility of the CD-ROM medium) seem tailored to fit the Naval Aviation technical documentation environment/functional specifications.

The space and weight considerations or advantages the optical media formats enjoy over the more bulky magnetic technology are indirectly detailed in Table 3. The space savings benefits associated with the optical media are rather intuitive even to the most casual observer glancing through the advantages and equivalency comparison Tables (see Tables 3, 4 and 6). The mailing/shipping costs savings associated with the optical media and more specifically the CD-ROM format, significantly favor the large-scale publication distribution regime. A comparison of the weights and resultant mailing costs between the various media analyzed throughout this paper are illustrated in two Figures--Figure 5.2 [Ref. 23: p. 42] offers a weight comparison chart of equivalent data storage, while the mailing costs to ship an equivalent data quantity by each medium (comprising of 540MB of data--equal to one 12cm (4.72") CD-ROM disc) is depicted in Figure 5.3 [Ref. 23: p. 25]. A more specific example depicting the initial outfitting costs of a Naval Aviation squadron converting to a CD-ROM technical documentation environment includes: data hardware acquisition, software development costs, and a mailing cost comparison of various media of both an initial issue and routine update is offered in Appendix C.

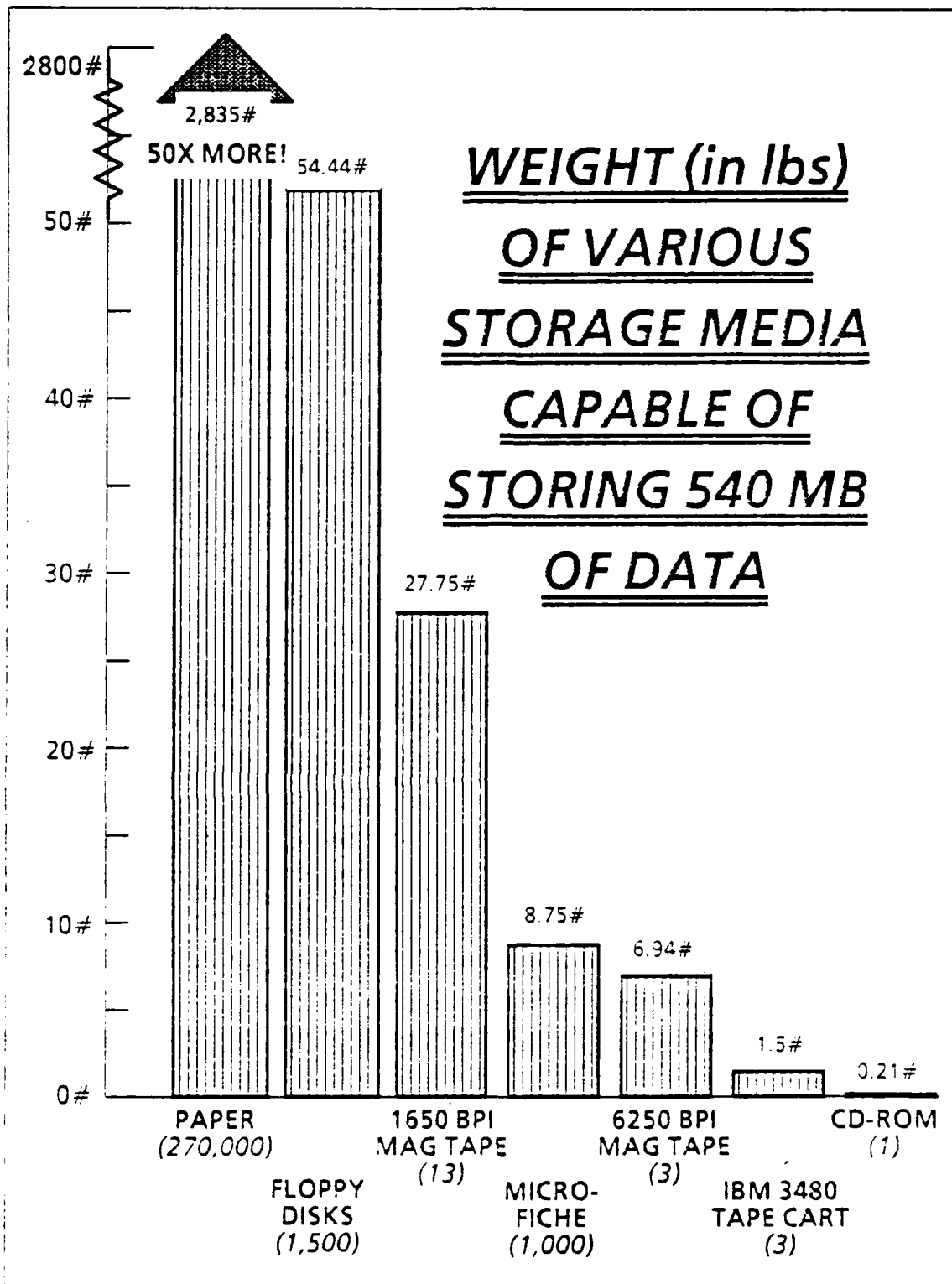

Figure 5.2 Weight of 540.MB In Various Media Formats.

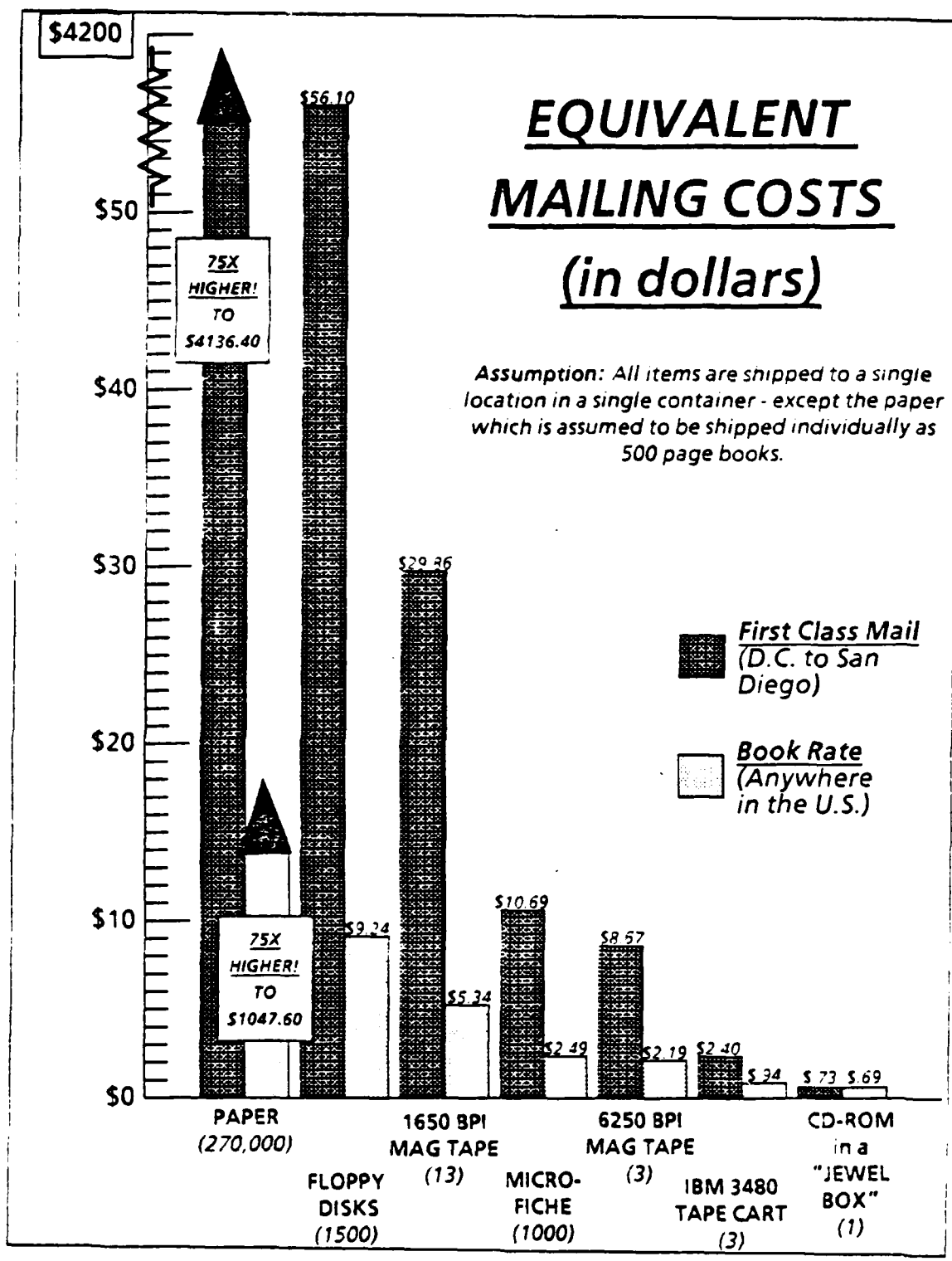

Figure 5.3 Equivalent Mailing Costs of 540MB Utilizing Different Media Formats.

## **VI. THE CD-ROM BOEING 757 AIRCRAFT MAINTENANCE MANUAL**

### **A. BOEING 757 CD-ROM BACKGROUND**

My initial objective for this thesis was to pursue the possibility of developing a very small-scale Naval Aviation maintenance manual prototype application on a CD-ROM disc. I realized a full-scale, comparative application had already been developed, following a presentation given by Diane Squire of the Publishers Data Service Corporation on the technical manual affinity to a CD-ROM application, in which a Boeing 757 maintenance manual mastered to a CD-ROM disc was demonstrated.

For the past year, the Technology Development Division of the Sundstrand Corporation, with the cooperation of British Airways and the Boeing Company, have been developing and evaluating an Advanced Data Management System (ADMS) for use in the mass storage, distribution and rapid retrieval of large technical databases such as aircraft maintenance manuals and illustrated parts catalogs on CD-ROM discs. The development program resulted in a prototype hardware and software system that was field tested by British Airways under actual line maintenance conditions in May of 1987. The prototype system went on display at the Paris Airshow the week of June 15.

The 'Beta' test program consisted of six retrieval stations in an operational environment, which replaced the microfilm applications in British Airways busiest and most used London locations. The stations were used by five shifts, 24 hours a day and seven days a week. This menu-driven Advance Data Management System provides data via one CD-ROM disc and includes the following types of airline information:

- aircraft maintenance manual
- illustrated parts catalog
- aircraft wiring diagrams
- troubleshooting manual
- airframe overhaul manual
- engine overhaul manual
- major subsystem manuals

The ADMS Data Retrieval Workstation consists of the following hardware components with a characteristic breakdown or description:

- \* computer
  - AT Bus and Operating System compatible

- 80386 microprocessor with 1 Megabyte of main memory
- 1.2 Megabyte 3.5" microfloppy disk drive
- hard disk
- two 540 Megabyte CD-ROM 'caddy drives'
- high resolution graphics adapter card
- two serial ports and one parallel port
- \* monitor
  - high resolution color: 1280 x 1024 pixels
  - near full-page presentation (9.5"H x 12.75"W -- 16" diagonal)
- \* printer
  - high resolution laser printer (300 dpi--8.5" x 11" page)
- \* keyboard
  - protected -- color coded function keys
- \* mouse
- \* modem
  - internal modem -- 2400 baud rate

The flexibility of the CD-ROM and the ADMS Data Retrieval Methods allows user to retrieve documents through a variety of different methods including:

1. mouse and keyboard
2. graphic symbols
3. book-like access
  - Airline Transport Association Document Number (ATA 100)
  - table of contents
  - full text search
4. full text search by:
  - word
  - phrase
  - text on illustrations
  - dictionary
5. bookmarks and stored inquiries
6. references and citations
7. full screen or split screen display
8. graphics pan and zoom
9. save selected sections of text and/or graphics
10. on screen help

A rough estimate as to personnel or labor savings and printing/material savings derived by the Sundstrand Corporation is depicted in Figure 6.1. These savings were determined using the assumptions that the ADMS reduces the mechanics' 'technical publication referencing time' by 50% and assuming laser printed material costs 90% less and electronic presentation vs. paper development costs 50% less.

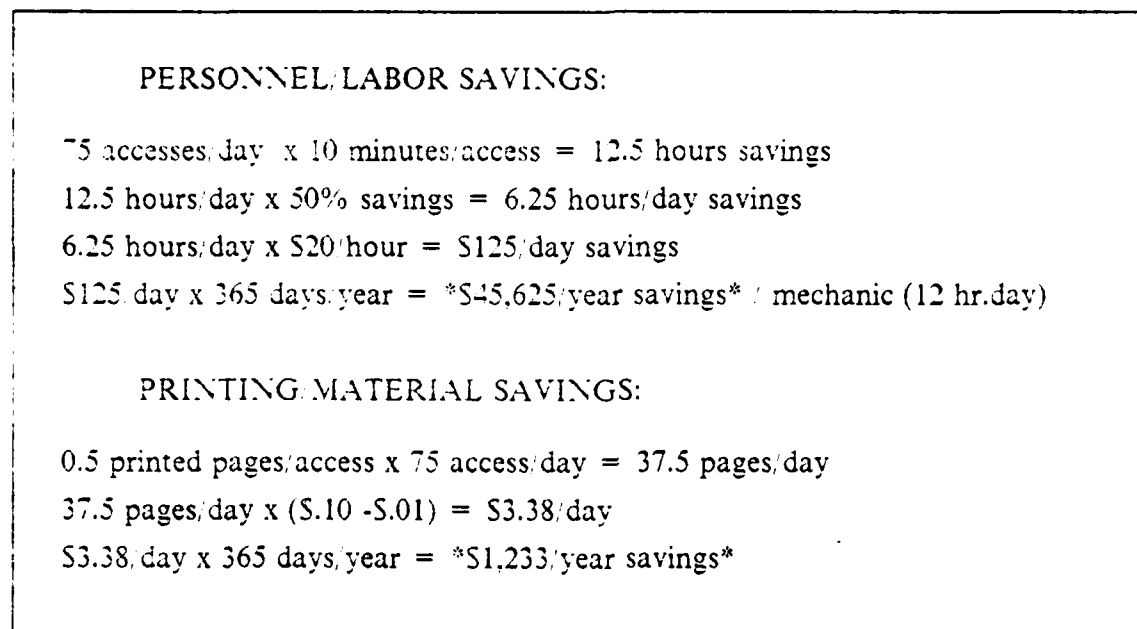

Figure 6.1 Estimated Automated Data Retrieval Savings Over Printed Documentation.

This prototype system proved most successful and impressed several other aircraft operators, including Federal Express and several U.S. Flag Commercial Carriers. In fact, several of these commercial carriers were impressed enough to commence their own CD-ROM disc database application analysis program.

The Sundstrand Corporation served as the overall hardware and software development agents contracting through OEM (original equipment manufacturers) for computers and drives and subcontracted the Boeing "57" aircraft maintenance data preparation and CD-ROM disc replication to KnowledgeSet Corporation of Monterey, California. The KnowledgeSet Corporation in cooperation with the Sony Corporation of America, formed a strategic alliance that offers a full range of service for CD-ROM disc and database preparation.

## B. DEVELOPMENT ISSUES

The sub-contracting data preparation development method used by the Sundstrand Corporation involved a complete optical publishing service package (software development and CD-ROM disc replication) offered by the KnowledgeSet Corporation and Sony Corporation affiliation. This alliance's organization includes four separate companies involved in the four major steps or processes involved in final CD-ROM disc delivery. The KnowledgeSet Corporation<sup>12</sup> teamed up with Sony and established a CD-ROM development team that included the formation of two separate companies--a data preparation service company named the Publishers Data Service Corporation, and a CD-ROM disc manufacturing and replication company known as Digital Audio Disc Corporation (DADC--a wholly owned subsidiary of Sony of America) of Terre Haute, Indiana. The CD-ROM optical publishing package consists of: hardware that can be provided by Sony, retrieval software developed and provided by KnowledgeSet, data preparation and tape mastering engineered by the Publishers Data Service Corporation (PDSC) and the actual disc manufacture, pressing and replication is handled by the Digital Audio Disc Corporation (DADC).

As alluded to throughout this paper, the indexing degree or 'word link tightness' coupled with the retrieval software's algorithm accounts for the speed or efficiency in accessing desired data. This database indexing and related file format set-up is the most time consuming, complex, and critical issue of CD-ROM disc preparation. This index 'engineering' requires an individual who is knowledgeable in both the subject matter of the database and the indexing methods of the retrieval software.

Because this indexing issue and subsequent retrieval software are critical processes in CD-ROM development and due to the availability of the KnowledgeSet and PDSC Corporations' Knowledge Retrieval System (KRS--both text and graphic applications), this systems' features, definitions and general system description are presented in Appendix D. Accompanying this 'user's introduction and command summary' enclosure are 'screen dumps' of both the visual presentation of the KRS introduction displays and copies of the actual hardcopy laser printouts of the Boeing 757 CD-ROM ADMS Workstation.

---

<sup>12</sup>founded by Gary Kildall, former Naval Postgraduate School Professor, founder and Boardchairman of Digital Research, Inc, and creator of the CP/M operating system.

## VII. CONCLUSIONS AND RECOMMENDATIONS

### A. OPTICAL MEDIA RECOMMENDATIONS

The DOD/DON have recognized the potential benefits of the optical storage technologies and have already authorized major research efforts, actual project acquisition programs and requests for proposals to implement optical storage techniques. This interest has generated the establishment of several research labs throughout the DOD. One DOD sponsored program that is heavily involved in the optical technology research includes:

The High Density Information Systems Laboratory (HIDS) in Alexandria, Va. The HIDS laboratory is an ongoing project of the Defense Applied Information Center, an effort spearheaded by the Office of the Secretary of Defense, the Organization of the Joint Chief of Staffs and the Defense Technical Information Center. . . . Optical memories technology is the primary high density information technology being evaluated at HDIS. [Ref. 29: p. 47]

The optical media technologies are getting significant press coverage. Practically every week there is an article in a government related publication (i.e., Federal Computer Week, Government Computer News, etc.) extolling the benefits of the optical media storage applications. An example of a few of these programs include: the Government Patent and Trademark Office's (GPTO) WORM application mentioned in Chapter V, continuing coverage of the Army's Electronic Information Delivery System<sup>13</sup> [Ref. 30: p.1,37] (EIDS), the Navy's technical documentation specification print on demand system that uses an optical storage application and the Internal Revenue Service's major application using optical technology.

In addition to those programs aimed at alleviating the storage and distribution problems of technical documentation previously mentioned in Chapters III and IV. There have been numerous references to new optical media application programs under development including a joint Army and Air Force program.

The Army and Air Force are jointly fielding an optical-disk storage system to manage millions of pages of technical drawings and specifications now stored on paper, film and plastic aperture cards.

---

<sup>13</sup>particularly in regards to a suit revolving around the contract award on who should develop this device that marries CD-ROM and interactive video technologies

Though the two services were able to combine their requirements into one program and one contract, they could not combine their acronyms. Thus the Air Force calls their system the Engineering Data Computer Assisted Retrieval System (EDCARS), and the Army calls it the Digital Storage and Retrieval System (DSREDS). [Ref. 31]

Certainly this type of program (similar to many in the DOD), as well as one related to the Naval Aviation maintenance technical documentation would classify as a large-scale publication and distribution environment. The CD-ROM format is inherently favorable to this very large-scale publishing environment (related to database size, number of user locations and the dispersal or location of the user sites), where environmental concerns, space considerations and database distribution efforts (mailing costs) are of a critical nature. This scenario precisely fits the Navy's data requirement environment.

As stated, many DOD/DON decision makers, project managers and research engineers have recognized the CD-ROM applicability to this type of military application. In an article predicting the government to become more involved with the CD-ROM format, both as a producer and purchaser of database materials, Stephen S. Smith, president of Reference Technology Inc., was quoted:

. . . "It is very clear that the government taken as a whole is going to be the major CD-ROM user in the next few years" . . . . The federal government is involved three ways in CD-ROM technology, Smith said.

First--the government is a good customer of many CD-ROM publishers and buys their products for their own use.

Second--the government as it tries to improve the productivity and capability of its employees is using CD-ROM to distribute information to personnel within its agencies.

Third--and the most controversial, involves the outside distribution of information that the government has collected or created in CD-ROM format. [Ref. 32: p. 26]

This article further identifies specific CD-ROM applications presently in use or under development within the DOD and identifies the IRS as the major CD-ROM customer with the DOD following as a close second and closing fast.

Another example of the increased government interest in the CD-ROM format relates to the growing size of a special interest group (SIG group) formed specifically for CD-ROM applications:

One indication of the level of interest within the government about CD-ROM is the special interest group on CD-ROM applications and technology, SIG-CAT. Formed a year ago to exchange information about CD-ROM applications in the federal government, the group has now grown to more than 850 members from more than 100 different agencies and the private sector.

"I've always believed that government was the biggest potential user of CD-ROM technology because of the extremely large data bases we sit on top of and now distribute in an expensive and archaic form," said Jerry McFaul . . . organizer of the SIG-CAT. . . . What makes the technology so appealing to users and product developers alike is the quantity and type of storage that can be obtained at such a low cost. . . . A single compact disc stores 550mb . . . more data than can be sent by a 1,200 bit/sec modem running 24 hours a day for six weeks. [Ref. 33: p. 23]

In fact, it's been said that the fastest, most inexpensive method of sending data is by CD-ROM via an overnight mail service. Inevitably, CD-ROM will prove more cost effective than direct access using modems and data links for applications in which the information is relatively stable and need not be updated with great frequency. There is the possibility of telecommunication links for small, immediate action revisions or updates to an aviation maintenance technical manual can be downloaded to a magnetic or WORM format environment that will include an indexing overlay. This new, telecommunicated indexing table will get accessed first and determine if the user's request or database search includes an updated section of the 'manual' on the CD-ROM disc. The operating system will virtually 'erase' or restrict the user from accessing any database area that has been revised or is in an outdated section of the publication. Until a new or updated disc is distributed, this 'temporary' access index table can be updated daily when the database is unstable and providing sufficient magnetic memory space is available. The frequency of preparing and replicating a new CD-ROM disc for distribution of course depends upon the stability of the data application--i.e., newer weapon systems would require a shorter revision cycle. I feel a quarterly revision cycle would be adequate and most cost effective, particularly if the hazards to flight safety and Rapid Action Maintenance Engineering Changes are distributed via an electronic telecommunication scheme. This quarterly revision cycle was utilized as the representative period for any analysis included in this paper requiring a revision schedule.

One of the most often asked questions and an important concern when transitioning to an optical media environment is the number of users, applications and

discs needed to justify CD-ROM or WORM. An article specifically addressing this subject area states:

According to the Information Workstation Group, CD-ROM is a good candidate for information dissemination when such conditions as the following are present:

- \* The number of end users exceeds 100, they are geographically dispersed and one local area network cannot serve all users.
- \* The information product is updated once a month or LESS frequently.
- \* Each end user is willing to expend \$1,000 a year for subscription to an information product that is updated annually. This sum will decrease as markets expand.
- \* The end users have accepted micro-computer technology and need access to data bases with computer search capability. To date, CD-ROM interfaces exist for most popular microcomputers, including those for Apple Computer Inc. and IBM Corp.
- \* The potential for detrimental impact on current information distribution approaches is understood.
- \* The organization distributing the database has marketing and technical experience with on-line data bases and microcomputer software or understands how to manage others who do. [Ref. 34: p. 33]

The WORM media, on the other hand, is most advantageous and cost effective when less than ten copies of an original are needed, a local area network or a very close geographic application is utilized, and the data is of the archival or very stable type.

A significant consequence or consideration to account for in researching the feasibility of transitioning the Naval Aviation technical documentation environment to the CD-ROM format relates to the data preparation and proprietary concerns of software retrieval development (i.e., input filters and data access customizing for more efficient database searching). Not only are these processes the most expensive of the CD-ROM development process, the issue of database security, ownership and authority to change data become important concerns.

As noted previously, research is underway to automate the indexing procedure and complete database preparation for CD-ROM development. Several companies are offering in-house CD-ROM development packages that enable the user, with the help of some automated indexing software tools, to format and pre-master data into a 'ready-to-press' CD-ROM product. It must be emphasized that the user controls the

data throughout the entire development process including: data acquisition, cleanup, conversion, indexing, simulation testing and pre-master tape generation. The CD-ROM testing or performance optimization is a significant benefit of this in-house development.

CD-ROM discs are not as fast as hard disks, but a number of techniques can be used to optimize the performance. . . . a method of testing such performance is to press a test disc (about \$5000 and a three week wait), then test the disc in the target PC environment. The application is then re-engineered, and another test disc is pressed to test improvements. Usually several such test discs are required.

An alternative is now available . . . using the CD Publisher (trademark), the CD-ROM developer is able to conduct realtime simulation testing in the target environment--without incurring the costs and time losses of data service development. [Ref. 35: p. 3]

To conclude this section on optical media recommendations I most strongly recommend continued research efforts and a progression to a formal feasibility study determining the cost benefits of CD-ROM media format applications to the Naval Aviation technical documentation publication and distribution methodologies. Furthermore, because of the significant cost and time savings achievable with in-house CD-ROM development and testing, I most strongly recommend the DOD DON investigate these advantages by acquiring an in-house CD-ROM development system similar to the Meridian Data Corporation's CD Publisher (trademark).

## **B. OPTICAL SCANNING CONVERSION ISSUES**

A major issue and concern faced by the Naval Air Technical Services Facility (NATSF), is the digitization of the literally miles of stored paper or microfiche based technical documentation. An objective of this research was to analyze this dilemma. This author specifically 'commissioned' the Palantir Corporation of Santa Clara, Ca. to assist in this research by conducting a scanning experiment on existing, common Naval Aviation technical documentation manuals. The purpose of this study was to compare the costs to automatically scan and digitize existing technical manuals versus a complete restructuring or a 'from scratch' development via a manual re-keying effort for text conversion with technical illustrations being digitized via a CAD/CAM system.

Two 'standard' Naval Aviation technical documentation manuals were utilized in this analysis and included: a CH-46E Natops Flight Manual (NAVAIR 01-250HDC-1), and a Maintenance Instruction Manual (MIMS) for the H-46 series on flight control:

systems (NAVAIR 01-250HDA-2-2.3). These two manuals were chosen due to their representative nature in regards to general Naval Aviation maintenance documentation including: various fonts, formats, letter size, illustrations, pictures, fold-out pages and relative familiarity with fleet users.

The Palantir Corporation analyzed and compared the two manuals concentrating on cost differences between scanning the documents via their Compound Document Processor (CDP) versus a total manual rekeying effort. Because the technology of the scanning digitization process is still in the developing stages, several obstacles precluded a complete analysis of digitizing the Naval Aviation technical documentation environment. For example, the photographs depicted in the NATOPS manual could not be scanned by the Palantir set-up (although there are scanners specifically designed for this application) and pages that were larger than 8.5" x 14" such as the fold-out schematics of the MIMS manual, could not be scanned and digitized. Additionally, the scan could not recognize some of the idiosyncrasies of the manuals. For example, the borders around the note, caution, and danger headings as well as the 'border bars' that signify a text change from the previous edition were not recognized by the scanner software. The issue of re-keying versus the scanning process is not really effected by this dilemma as a typist or text processor could not duplicate many of these idiosyncrasies without a specialized 'paint' or graphic bit mapping editor program. The cost of digitizing existing technical drawings via a CAD/CAM system did not enter this analysis and comparison due to the unavailability of the costing data.

Mr. Athol Fodon, Palantir's Senior Technical Support Engineer, conducted the analysis and made some assumptions for the test runs including: all graphics would be represented via raster scan without compaction, the amortization schedule would utilize a one year pay-off, the accuracy rate requirement for scan would be 98%, utilization of a \$7.74 manual re-keying labor cost and total annual CDP system cost to equal \$60,550. Three representative pages from each manual would be scanned to obtain: an average character count per page, scan time per page and edit time (corrections) per page.

Appendix A presents several spreadsheet reproductions representing two runs that compare the scanning process to manual re-keying. One run represents a full page of text scan while the second runs assumes a 2/3 text and 1/3 graphics page representation. Ten variables or ten columns represent the different daily machine (CDP) run time or pages scanned per day. The two different page compositions

accounted for the different read or scan times. This time difference was due to the longer CPU times the more sophisticated character recognition algorithms require for text recognition (ascii conversion) versus raster scan for graphics. This difference coupled with the variable of machine daily usage or pages read per day accounts for the different payback periods.

The bottom line cost analysis surfaces or become more clear in the row depicting the number of pages required to be scanned to recover system cost and is of course variable on the volume of pages scanned per time. The spread sheet runs are reproduced as the second enclosure to Appendix A with the full text page (93.5 seconds per page transit time) listed as run one, and the 1/3 graphics and 2/3 text page (83.5 seconds per page transit time) included as the second run. Preceding the spreadsheet analysis and listed as enclosure one of Appendix A, is a Palantir newsrelease or marketing paper, that is included for the concise description of the CDP system, terminology and definitions of the scanning process, and explanations as to some of problems encountered in this environment and processes this system employs to capture documentation in a digitized format.

### **C. RASTER VS VECTOR IMAGING RECOMMENDATIONS**

A significant factor that influences the scanning versus rekeying efforts is the conversion of raster scanned digitized data to vector representation. This issue becomes critical in the CAD/CAM environment or when interactive presentations will be part of an electronic maintenance documentation program with diagrams or illustrations that will be 'manipulated' (i.e., magnified, rotated, isolated, etc.) on the screen by the user. The storage or memory usage of the vector graphics (usually much less than the raster scanned method--even with significant compaction algorithms) is a very beneficial by-product of this conversion.

Appendix B illustrates the present software technology and efforts involved in the attempt to convert raster scanned engineering drawings to a vector representation for CAD/CAM applications. The study, initiated by the Sundstrand Corporation was executed by several companies under a joint contract arrangement. The analysis utilized an initial raster scanning process which was translated to a vector representation based upon the Boeing Magic Format Vectorization System. The illustrations depicted in Appendix B are reproductions of several final print-out examples included in a final report compiled by the Sundstrand Corporation. The diagrams are arranged such that the vector initial representation is below the vector

enlarged image which has been circled on the original illustration. The circled or enlarged areas are expanded by a 200% (2X) factor.

The recognition software was designed to identify and convert text to ascii format while also interpret geometric entities such as lines, curves, circles, splines, etc. The study concluded that present technology of the raster scan to vector conversion lacked sufficiently advanced image recognition hardware/software for sophisticated applications required by a CAD/CAM or 'diagram manipulation' environment.

The software/hardware scanner system developed by the Palantir Corporation (Compound Document Processor--CDP), and presented in Appendix A, has improved significantly on this technology in the few short months since the Sundstrand Corporation compiled their final report presented in Appendix B. However, this improvement has not yet reached a technical sophistication level where the DOD/DON should embark upon a raster scan to vector conversion project. I do recommend further research or investigation into this area. I am quite confident that within two years, the scanning methods and raster to vector conversion process will transcend to a level that will accommodate the digitization of the archives of technical documentation required by the CALS directive.

#### **D. NAVAL AVIATION TECHNICAL DOCUMENTATION PROJECTIONS**

According to Joe Fuller, the Navy's NTIPS program senior research analyst, the Navy and Air Force are pursuing a joint effort relating to the very topic this paper has been researching--automated delivery of the aviation technical manual environment. The proposed (on the 'drawing board') program has been initially termed the IMIS (Integrated Maintenance Information System) program. This program is designed to work in conjunction with the NTIPS program and specifically interface with the hardware environments of the Navy--NALCOMIS, SNAP, and those of the Air Force. This most certainly is a major effort with many issues yet to be resolved. The shipboard environment differences is just one area that will preclude an easy interfacing solution with the Air Force.

As mentioned previously, the NTIPS project office conducted several experiments relating to the electronic representation and delivery of aviation maintenance technical documentation. The NAS Miramar scenario included an operational F-14 squadron. Several faults were inserted into the flight control systems and 24 Aviation Electricians<sup>14</sup> (AE's), were monitored through an experiment that included computer

---

<sup>14</sup>rates ranging from E-3 Airmen to E-6 First Class Petty Officers

delivered technical documentation. The groups were broken down into experimental and control groups for comparison, and also were rotated through both the conventional and electronic device methods of technical documentation representation. The maintenance actions included trouble-shooting, corrective and/or scheduled types of maintenance. The results concluded that the electronic delivery systems worked well, were easy to operate<sup>15</sup> and were preferred by 20 of the 24 technicians. The exceptional initial success of this program is aptly demonstrated by the fault isolation figures compiled upon completion of the experiment. The correct identification of the intentionally inserted faults was recognized in only 25% of the cases using the conventional paper based technical information (TI) method while 12 out of 12 were successful with the electronic delivery system. Additionally, 35% fewer errors were made using the new approaches than with the conventional manuals (TI).

In summary, this field test showed that under operational conditions, the technicians performed their maintenance tasks more effectively using the new presentation methods, than with the conventional manual. This was true for both the experienced and inexperienced technician. Examining user acceptance, the test showed that the technicians preferred the electronic display to paper presentation. The fleet personnel also observed that the electronic display would be easier to support in the field; by saving space, and being easier to update. Finally, the test showed that it is feasible for an aerospace contractor to prepare improved system support Technical Information (TI) using automated methods.

The results of this test, (from which I obtained a portion of the figures referenced above), were recorded to a video presentation and made available for my viewing by Mr. Joe Fuller of the David Taylor Naval Ship Research and Development Center.

The human factors issues, environmental tolerances and long-term effectiveness of this type of system need further investigation, of course, but with initial results like these, it's not a difficult decision to recommend an optical media technical documentation feasibility study relating to the this environment. As noted previously, the Navy has sponsored a major militarized optical disc study being conducted by the Fairchild Industries, INC. in conjunction with the Sperry Corporation. These contractors have prepared extensive reports on the ruggedization qualities of optical media when exposed to the extreme military environment including aeronautical and battle applications (See Ref. 18 and Bibliography). Additionally, the newly developing technologies of the interactive or multi-media application CD discs may soon

---

<sup>15</sup>the average training time for operating the device was 15 minutes

overshadow the excitement now given to the read-only discs.

Three CD-ROM standards are vying for attention. . . . General Electric and RCA demonstrated a new compression/decompression technology called Digital Video Interactive (DVI). DVI lets a minicomputer analyze and squeeze an hour of video images onto a single CD-ROM disc. . . . CD-I is another CD-ROM interactive standard that was introduced by Sony and Philips. . . . another standard introduced by Philips is a CD-V format for Compact Disc-Video . . . not a CD-ROM at all but could be played on a drive that could also read CD-ROMs. . . . This 'video single', offers digital audio sound along with five minutes of video image. [Ref. 36: p. 5F]

The training implications of these types of data delivery systems particularly in a technical maintenance training or simulator type environment are obvious. In fact, the Army's EIDS program is developing this technology and whether it is delivered via a CD format or a final version similar to the 12" 'Laserdisks' of yesteryear remains to be seen. Nevertheless the DOD is very interested in this type of application, and rightly so.

The Office of the Secretary of Defense has established two laboratories for optical disk experimentation and demonstration. One of the laboratories focuses on compact-disc interactive (CD-I) systems, which are primarily used for training. The CD-I lab, run by contractor Pace Enterprises of Falls Church, Va. . . . is investigating alternative applications of this medium which combines video, sound and text on a single laser disk. The user controls the flow of the program by interacting through input devices such as keyboard, touchscreen or mouse. [Ref. 37: p. 1,17]

The CD-I, DVI and CD-V media are still too immature and volatile to implement any DOD/DON programs as of yet, however due to this avid DOD interest and lab sponsorship, I believe the scenario I presented in the introductory Chapter of this paper are closer at hand than many realize. In fact, prior to doing this research on the optical media, I would have been counted as one who would not have believed the speed at which these technologies have been developing.

The Navy is however, pursuing in a very determined manner another goal mentioned at the outset of this paper--The 'Paperless Ship' Concept.

The Navy Department has a contract with Reteaco Inc. of Willowdale, Ontario, to produce CD-ROM discs containing repair and part number information for shipboard use. . . . in order to achieve the 'paperless ship'

concept being promoted in some sectors of the Navy. According to the Navy's Dave Connelly, . . . the service would order "probably on the order of a thousand or so". [Ref. 38: p. 68]

Certainly this 'futuristic' data delivery system, when applied to the Naval Aviation Community technical documentation publication and distribution environment could establish the goal of a 'paperless aviation squadron'. The technology is here. The challenge remains for the Navy, DOD, and industry to provide an efficient and standardized state-of-the-art Technical Information System. This improved system will provide the Navy with increased weapon system availability and greater striking power.

In conclusion, I must offer the insights of a true information system visionary, a pioneer who may be regarded as the (pardon the reference) mother of the Navy's Computer Program--Admiral Grace Hopper. An optical technology advocate, Admiral Hopper is quoted in an interview:

Hopper expects high-conductivity semi-conductors to have a profound influence on computers in the coming years. . . . Even before that, optical transmission of information will become a prominent technology. "It has tremendous advantages," she said. "You can't listen to optical, you can't tap it, and it's completely independent of the electromagnetic pulse. We will need all our ships and planes equipped with optical transmission instead of electronic." [Ref. 39: p. 42]

If Admiral Hopper can make a proclamation like that, than I feel comfortable predicting that I will be utilizing some optical media technology before I'm out of the flying business.

**APPENDIX A**  
**SCANNER VS. DATA RECONSTRUCTION COST COMPARISON**

This appendix consists of a study specifically 'commissioned' for this research and conducted by the Palantir Corporation of Santa Clara, Ca. The purpose of this study was to compare the costs to automatically scan and digitize existing technical manuals versus a complete restructuring or a 'from scratch' development via a manual re-keying effort with technical illustrations being digitized via a CAD/CAM system.

Two 'standard' Naval Aviation technical documentation manuals were utilized in this analysis and included: a CH-46E Natops Flight Manual (NAVAIR 01-250HDC-1), and a Maintenance Instruction Manual (MIMS) for the H-46 Helicopter series on flight control systems (NAVAIR 01-250HDA-2-2.3). Figure A.1 depicts the six test run results consisting of three pages from each manual with keystrokes (characters/page), scan time, and editing (correction) time listed by run number.

NATOPS MANUAL RESULTS:			
RUN NO.	CHAR. PG.	SCAN TIME (mins)	EDIT TIME (mins)
1	4613	1.46	4
2	5198	2.05	3
3	4720	2.07	3
MAINTENANCE INSTRUCTION MANUAL (MIMS):			
RUN NO.	CHAR. PG.	SCAN TIME (mins)	EDIT TIME (mins)*
4	3350	3.00	5
5	5641	2.15	1
6	5002	3.18	7

\* (Note MIMS manual required longer edit times due to special characters)

Figure A.1 Experimental CDP Scanning Test Run Results.

The following reproduction consists of a marketing/newsrelease, published by the Palantir Corporation. This 'advertisement' is included due to: the concise description of the CDP system, terminology and definitions of the scanning process, and explanations as to some of problems encountered in this environment and processes this system employs to capture documentation in a digitized format.

**NEW, INTELLIGENT DOCUMENT PROCESSOR  
FROM PALANTIR AUTOMATICALLY  
HANDLES VARIETY OF TYPE FONTS, STYLES  
AND PAGE FORMATS NOT POSSIBLE BEFORE**

SANTA CLARA, California, May 16, 1986 -- A new answer to the problem of automatically turning text and graphics into computer-usable form was announced today by The Palantir Corporation.

"Trillions of documents are generated every year by business, government, science and academia and, until now, there have been only limited means of converting the information from them into data that can be processed by a computer", said Daniel A. Macuga, president.

"The new Palantir Compound Document Processor (CDP) is the only product on the market that can read typeset or typewritten text in virtually any size, style or format without requiring the system to be manually trained. Further, it combines that feature with the ability to process bit-mapped images from any source and provides for Smart Host™ forms processing, all in the same device," he added.

According to Mr. Macuga, the CDP's open architecture allows it to communicate with a variety of host computers using standard communications protocols, and it can function as a standalone device, or as a network server for shared text and image processing.

Typically the CDP works as part of a larger system that includes a host computer, display device, mass storage and a printer.

Products like this can be expected to have wide application in electronic publishing, database building, forms processing and data entry. Any organization that must transfer information from paper documents and other sources into a computer for processing and storage is a potential customer.

The Palantir system would, for instance, make an ideal device to enter material into optical storage devices, which can hold tens of thousands of pages of information, but are hobbled by the amount of time it takes to fill them with information from the printed page.

Other products on the market, called optical character readers, fall into three categories: 1) Low-priced page readers limited to a handful of type fonts (styles), sizes and page layouts. 2) Expensive page readers that must be manually trained to read a variety of type fonts, and 3) Very expensive forms readers that emphasize reading and paper-moving speed at the expense of flexibility.

Unlike these devices, the Palantir CDP provides: 1) Omnifont character recognition that requires no manual training, 2) Omniformat page processing that permits all the information to be extracted from even highly complex documents (e.g. with multiple columns and imbedded text and graphics) without requiring any manual pre-processing, 3) Image processing under program control, at a resolution of 300 dots per inch, and 4) Smart Host™ programming that permits upto 256 individual zones of information (text and image) on each document to be defined and processed.

### **Breakthrough Technology**

Palantir's prime contribution involves the development of proprietary character recognition algorithms. These algorithms allow the CDP to recognize characters by their attributes, rather than trying to make exact matches to each number and letter, line by line, length by length, angle by angle.

Because of this recognition by abstractions rather than matrix (template) matching or feature extraction, the CDP does not require that the computer be "trained" to recognize new type styles or sizes, nor does the customer have to buy new font sets.

These algorithms are contained in a Palantir-designed recognition engine that combines five Motorola 68000 microprocessors with custom-designed integrated circuits and a parallel-processing computer architecture. Three megabytes of dynamic memory and one and one-half megabyte of custom software in read-only memory are also included.

The recognition engine, heart of the CDP, provides the intelligence to turn text or images from any source into ASCII computer code or bit-mapped raster images that can be processed and stored by a host computer.

### **Omnifont Character Recognition**

With omnifont character recognition, the Compound Document Processor can read many thousands of typeset and typewritten fonts and sizes, whether in the form of continuous text or as compound documents (text and images on the same page).

The CDP can also read pages that contain a variety of fonts and sizes, as well as proportionally-spaced and monospaced type.

Proprietary algorithms and spelling dictionaries allow the system to make "best guess" fits for characters that may be broken, faint, or otherwise hard for the system to read.

### **Omniformat Page Processing**

The CDP can extract all the text and image information from a document, regardless of the complexity of the page layout. Simple documents, such as business letters with single columns, can easily be processed by the CDP, but

the CDP can also process pages with multiple columns, imbedded images, and other complex formats (such as text run-arounds).

No manual pre-processing, such as electronically marking columns and images, is necessary. The CDP automatically adapts to each page, as it differentiates between textual information and graphics, locates all text between six and 28 point size and extracts the text. The system does all this while maintaining information about page layout and character point size, in order to facilitate reconstruction of the "look" of the page.

### **Image Processing**

The CDP captures both text and image information simultaneously in a single scan of a page. Images are scanned at a resolution of 300 dots per inch, and can be captured even from poor quality originals. Image data can be compressed and transmitted according to CCITT Group 3 and Group 4 facsimile standards, both for storage economy and to provide standard transmission formats.

This compression can reduce the number of bytes needed to transmit and store an image by as much as a factor of 30.

Images from intelligent scanners, optical disk systems and other computers can be accepted and processed by the CDP through industry-standard interfaces.

### **Forms Processing**

Both OCR and standard forms can be handled by the Compound Document Processor. The Smart Host™ mode allows users to program the host computer so that the system can read different types of forms automatically.

The system can handle several types of forms in one input stack because of this ability to recognize information in key sections of a document, such as

the form number zone on a tax form.

Under host computer or operator control, the CDP can choose up to 256 user-definable zones. In this way, for instance, only pertinent information can be stored, thus saving memory. Or, if the selected zone contains key information, such as a form number, it can be used to determine how the remaining material is to be processed.

Text can be retrieved with or without the accompanying images, or vice versa.

The operator or the host computer can also specify which sections of a form contain alphanumeric, alpha, numeric or image information. Documents can be read in either portrait (vertical) or landscape (horizontal) modes.

### **System Configurations**

The Compound Document Processor communicates with host computers or networks through standard serial RS-232 and optional Multibus<sup>®</sup> and Ethernet<sup>®</sup> interfaces.

Palantir will provide a series of UNIX<sup>®</sup>- and PC-DOS-based packages for file editing and correction and forms processing, as well as a set of libraries and utilities designed to speed integration of the CDP into customers' systems.

This combination of interfaces and utilities is designed to give OEMs, System Integrators and Value-Added Resellers maximum flexibility in designing the CDP into their own systems for specific market areas and applications.

### **Prices and Availability**

The Palantir Compound Document Processor has a suggested single quantity end-user price of \$39,500. Customer deliveries have begun, and current availability is 60 days ARO. Quantity discounts are available.

The following reproductions consist of a spreadsheet analysis generated by the Palantir Corporation. This cost benefit analysis compares the scanning process using the Compound Document Processor(CDP) developed by the Palantir Corporation versus a manual re-keying effort.

ASSUMPTIONS	1	2	3	4	5	6	7	8	9	10
<b>HW-Office/Software Costs</b>										
CDP System Cost	39,500	39,500	39,500	39,500	39,500	39,500	39,500	39,500	39,500	39,500
CDP Hd Options	6,000	6,000	6,000	6,000	6,000	6,000	6,000	6,000	6,000	6,000
CDP Host and Application SW Cost	5,000	5,000	5,000	5,000	5,000	5,000	5,000	5,000	5,000	5,000
CDP Service Cost/Year	4,550	4,550	4,550	4,550	4,550	4,550	4,550	4,550	4,550	4,550
Host System Cost	5,000	5,000	5,000	5,000	5,000	5,000	5,000	5,000	5,000	5,000
Mark Station Cost	5,000	5,000	5,000	5,000	5,000	5,000	5,000	5,000	5,000	5,000
Total Mark Station Cost	0	0	0	0	0	0	0	0	0	0
Percent Host for Reject/Reentry	1.00	1.00	1.00	1.00	1.00	1.00	1.00	1.00	1.00	1.00
Net Host Cost for CDP, RI/RE	5,000	5,000	5,000	5,000	5,000	5,000	5,000	5,000	5,000	5,000
Total System Cost	55,500	55,500	55,500	55,500	55,500	55,500	55,500	55,500	55,500	55,500
# of Years Amortization	1	1	1	1	1	1	1	1	1	1
Host Service Cost/Year	500	500	500	500	500	500	500	500	500	500
Net Host Service Cost/Year	5,100	5,500	5,500	5,500	5,500	5,500	5,500	5,500	5,500	5,500
CDP Cost/Year	55,050	55,050	55,050	55,050	55,050	55,050	55,050	55,050	55,050	55,050
Total System Cost/Year	60,550	60,550	60,550	60,550	60,550	60,550	60,550	60,550	60,550	60,550
<b>CDP PARAMETERS</b>										
Run Up Time/Day (Hours)	0.5	1.0	1.5	2.0	2.5	3.0	3.5	4.0	4.5	5.0
Number of Marking Days/Week	5.0	5.0	5.0	5.0	5.0	5.0	5.0	5.0	5.0	5.0
# Characters/Page	3,000	3,000	3,000	3,000	3,000	3,000	3,000	3,000	3,000	3,000
Accuracy Rate	0.999	0.999	0.999	0.999	0.999	0.999	0.999	0.999	0.999	0.999
Zone Download Time (Sec/Page)	0.0	0.0	0.0	0.0	0.0	0.0	0.0	0.0	0.0	0.0
Scan/Inge Load DN (Sec/Page)	1.0	1.0	1.0	1.0	1.0	1.0	1.0	1.0	1.0	1.0
Recognition Speed (Char/Sec)	50.0	50.0	50.0	50.0	50.0	50.0	50.0	50.0	50.0	50.0
Text Transmit Time (Sec/Sec)	2.5	2.5	2.5	2.5	2.5	2.5	2.5	2.5	2.5	2.5
Image Compress Time (Sec/Page)	0.0	0.0	0.0	0.0	0.0	0.0	0.0	0.0	0.0	0.0
Image Transmitt Time (Sec/Page)	20.0	20.0	20.0	20.0	20.0	20.0	20.0	20.0	20.0	20.0
Total Sec/Page	83.50	83.50	83.50	83.50	83.50	83.50	83.50	83.50	83.50	83.50
# Pages/Hour	43	43	43	43	43	43	43	43	43	43
# Pages/Day	22	43	65	86	108	129	151	172	194	216

• Pages/Week 108 216 323 431 539 647 754 862 970 1,078  
 • Pages/Month 449 898 1,347 2,096 2,946 3,695 4,444 5,193 5,942 6,691  
 • Pages/Year 5,389 10,778 16,167 21,557 26,946 32,335 37,725 43,114 48,503 53,892

**FORMATTING & ERROR CORRECTION**

Page Layout/Day Time (Sec/Page) 30.0 30.0 30.0 30.0 30.0 30.0 30.0 30.0 30.0 30.0  
 Seconds/Error Fixed 2.5 2.5 2.5 2.5 2.5 2.5 2.5 2.5 2.5 2.5  
 Errors/Page 36 36 36 36 36 36 36 36 36 36  
 Total Errors/Day 776 1,552 2,328 3,104 3,880 4,656 5,432 6,208 6,984 7,760  
 Total Layout Hours/Day 0.2 0.4 0.5 0.7 0.9 1.1 1.3 1.4 1.6 1.8  
 Error Correcting Hours/Day 0.5 1.1 1.6 2.2 2.7 3.2 3.8 4.3 4.9 5.4  
 CDP Attendance Hours/Day 0.1 0.1 0.2 0.2 0.3 0.3 0.4 0.4 0.5 0.5  
 Total Data Entry/Verify Hours/Day 0.8 1.5 2.3 3.1 3.8 4.6 5.4 6.1 6.9 7.7

**LABOR COSTS FOR CDP TEXT ENTRY**

Labor/Hour 20.34 20.34 20.34 20.34 20.34 20.34 20.34 20.34 20.34 20.34  
 Total Hours of Labor/Year 192 304 576 769 961 1,153 1,345 1,537 1,729 1,921  
 Total Labor Costs/Year 3,903 7,016 11,721 15,633 19,541 23,443 27,357 31,265 35,173 39,081

**CDP VS KEY ENTRY COSTS/YEAR**

Key Entry Cost/1000 Characters 1.72 1.72 1.72 1.72 1.72 1.72 1.72 1.72 1.72 1.72  
 CDP HH Cost/1000 Characters 3.40 1.70 1.13 0.85 0.68 0.57 0.49 0.43 0.38 0.34  
 Host HH Cost/1000 Characters 0.34 0.17 0.11 0.09 0.07 0.06 0.05 0.04 0.04 0.03  
 CDP Labor Cost/1000 Characters 0.24 0.24 0.24 0.24 0.24 0.24 0.24 0.24 0.24 0.24  
 Total CDP Cost/1000 Characters 3.99 2.11 1.49 1.18 0.99 0.87 0.78 0.71 0.66 0.62  
 CDP Savings/1000 Characters -2.27 -0.39 0.23 0.54 0.73 0.85 0.94 1.01 1.06 1.10  
 Key Entry Cost/Page 5.16 5.16 5.16 5.16 5.16 5.16 5.16 5.16 5.16 5.16  
 CDP HH Cost/Page 10.21 5.11 3.40 2.55 2.04 1.70 1.46 1.28 1.13 1.02  
 Host HH Cost/Page 1.02 0.51 0.34 0.26 0.20 0.17 0.15 0.13 0.11 0.10  
 CDP Labor Cost/Page 0.73 0.73 0.73 0.73 0.73 0.73 0.73 0.73 0.73 0.73  
 Total CDP Cost/Page 11.96 6.34 4.47 3.53 2.97 2.60 2.33 2.15 1.97 1.85  
 CDP Savings/Page -6.80 -1.18 0.69 1.63 2.19 2.56 2.83 3.03 3.19 3.31

Total Key Entry Cost 27,808 55,617 83,425 111,234 139,042 166,850 194,659 222,467 250,275 278,084  
 Total CDP Entry Cost 64,458 68,366 72,274 76,183 80,091 83,999 87,907 91,815 95,723 99,631  
 Total CDP Entry Savings (36,650) (12,750) 11,151 35,051 58,951 82,851 106,752 130,652 154,552 178,452

**CDP COST RECOVERY UNDER AMORTIZATION PERIOD**

Pages to Recover IUP Cost (8,045) (46,539) 79,818 31,857 25,163 21,485 19,454 18,166 17,276 16,625  
 Hours to Recover CDP Cost -78.1 -221.5 256.7 81.7 46.6 34.6 26.8 21.9 18.5 16.0  
 Pages to Recover System Cost (8,904) (51,183) 87,793 37,220 27,677 23,632 21,398 19,941 19,002 18,286  
 Hours to Recover System Cost -65.9 -247.0 262.4 89.8 53.4 38.0 29.5 24.1 20.4 17.6

WORKSTATION/STATION COSTS

COP System Cost	39,500	39,500	39,500	39,500	39,500	39,500	39,500	39,500	39,500	39,500
COP HI Options	6,000	6,000	6,000	6,000	6,000	6,000	6,000	6,000	6,000	6,000
COP Host and Application SM Cost	5,000	5,000	5,000	5,000	5,000	5,000	5,000	5,000	5,000	5,000
COP Service Cost/Year	4,550	4,550	4,550	4,550	4,550	4,550	4,550	4,550	4,550	4,550
Host System Cost	5,000	5,000	5,000	5,000	5,000	5,000	5,000	5,000	5,000	5,000
Work Station Cost	5,000	5,000	5,000	5,000	5,000	5,000	5,000	5,000	5,000	5,000
Total Work Station Cost	0	0	0	0	0	0	0	0	0	0
Percent Host for Reject/Reentry	1.00	1.00	1.00	1.00	1.00	1.00	1.00	1.00	1.00	1.00
Net Host Cost for COP, RJ/RE	5,000	5,000	5,000	5,000	5,000	5,000	5,000	5,000	5,000	5,000
Total System Cost	55,500	55,500	55,500	55,500	55,500	55,500	55,500	55,500	55,500	55,500
# of Years Amortization	1	1	1	1	1	1	1	1	1	1
Host Service Cost/Year	500	500	500	500	500	500	500	500	500	500
Net Host Service Cost/Year	500	500	500	500	500	500	500	500	500	500
Host System Cost/Year	5,500	5,500	5,500	5,500	5,500	5,500	5,500	5,500	5,500	5,500
COP Cost/Year	55,050	55,050	55,050	55,050	55,050	55,050	55,050	55,050	55,050	55,050
Total System Cost/Year	60,550	60,550	60,550	60,550	60,550	60,550	60,550	60,550	60,550	60,550

COP PARAMETERS

Avg Up Time/Day (Hours)	0.5	1.0	1.0	1.0	1.0	1.0	1.0	1.0	1.0	1.0
Number of Working Days/Week	5.0	5.0	5.0	5.0	5.0	5.0	5.0	5.0	5.0	5.0
Number of Working Weeks/Year	50.0	50.0	50.0	50.0	50.0	50.0	50.0	50.0	50.0	50.0
# Characters/Page	4,500	4,500	4,500	4,500	4,500	4,500	4,500	4,500	4,500	4,500
Accuracy Rate	0.988	0.988	0.988	0.988	0.988	0.988	0.988	0.988	0.988	0.988
Zone Download Time (Sec/Page)	0.0	0.0	0.0	0.0	0.0	0.0	0.0	0.0	0.0	0.0
Scan/Image Load OH (Sec/Page)	1.0	1.0	1.0	1.0	1.0	1.0	1.0	1.0	1.0	1.0
Recognition Speed (Char/Sec)	50.0	50.0	50.0	50.0	50.0	50.0	50.0	50.0	50.0	50.0
Text Transmit Time (Sec/Page)	2.5	2.5	2.5	2.5	2.5	2.5	2.5	2.5	2.5	2.5
Image Compress Time (Sec/Page)	0.0	0.0	0.0	0.0	0.0	0.0	0.0	0.0	0.0	0.0
Image Transmit Time (Sec/Page)	0.0	0.0	0.0	0.0	0.0	0.0	0.0	0.0	0.0	0.0
Total Sec/Page	93.50	93.50	93.50	93.50	93.50	93.50	93.50	93.50	93.50	93.50
# Pages/Hour	39	39	39	39	39	39	39	39	39	39
# Pages/Day	19	37	77	116	135	154	173	193	213	233
# Pages/Week	96	193	385	401	578	674	770	866	963	1059
# Pages/Month	401	802	1,604	2,406	2,406	3,209	3,209	3,209	4,011	4,011
# Pages/Year	4,813	9,626	19,251	24,064	28,877	33,690	38,503	43,316	48,129	48,129



1-C

1-1

1-25

REF ID: A66666

2-8

3-15

3-5

4-0

4-5

2-8

2-2

2-0

1-8

1-4

1-6

Page Layout/On Time (Sec/Page)  
 Seconds/Error Fixed  
 Errors/Page  
 Total Errors/Day  
 Total Layout Hours./Day  
 Error Correcting Hours./Day  
 CDP Attendance Hours./Day  
 Total Data Entry/Verify Hours./Day

LABOR COSTS FOR CDP TEXT ENTRY/  
 Labor./Hour  
 Total Hours of Labor./Year  
 Total Labor Costs./Year

CDP VS KEY ENTRY COSTS: YEHP  
 Key Entry Cost/1000 Characters  
 CDP HI Cost/1000 Characters  
 Host HI Cost/1000 Characters  
 CDP Labor Cost/1000 Characters  
 Total CDP Cost/1000 Characters  
 CDP Savings/1000 Characters

Key Entry Cost Page  
 CDP HI Cost/Page  
 Host HI Cost/Page  
 CDP Labor Cost/Page  
 Total CDP Cost/Page  
 CDP Savings/Page  
 Total Key Entry Cost  
 Total CDP Entry Cost  
 Total CDP Entry Savings

CDP COST RECOVERY (MER  
 AMORTIZATION PERIOD)  
 Pages to Recover CDP Cost  
 Needs to Recover CDP Cost  
 Pages to Recover System Cost  
 Needs to Recover System Cost

## APPENDIX B RASTER SCAN CONVERSION TO VECTOR REPRESENTATION

This appendix illustrates the present software technology and efforts involved in the attempt to convert raster scanned engineering drawings to a vector representation for CAD/CAM applications. The following illustrations are reproductions of several final print-out examples included in a final report compiled by the Sundstrand Corporation. The diagrams are arranged such that the circled or enlarged areas (which have been expanded by 200% or a 2X factor), are pictured above the original or 'baseline' raster to vector conversion representation.

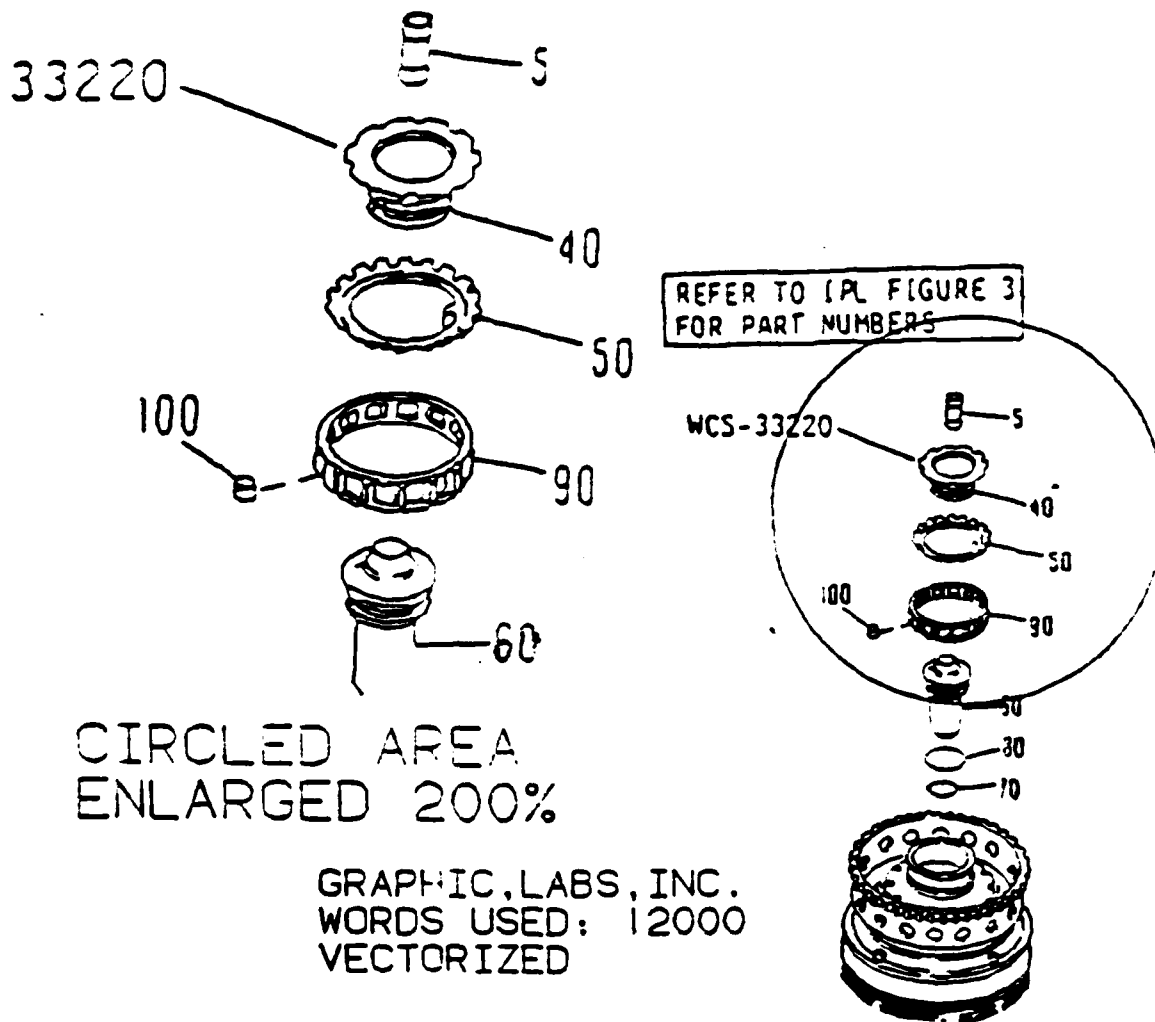

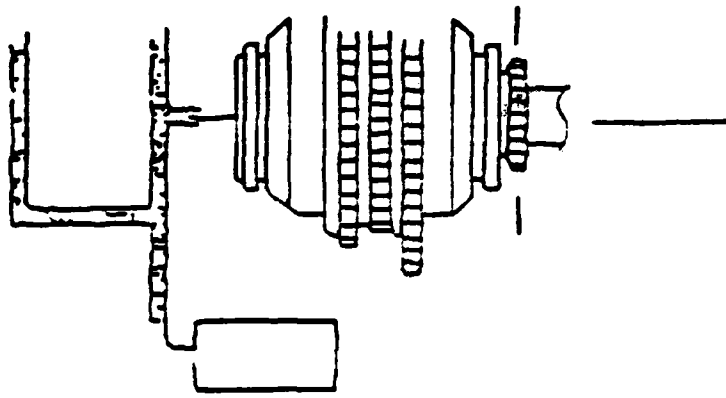

CIRCLED AREA  
ENLARGED 200%

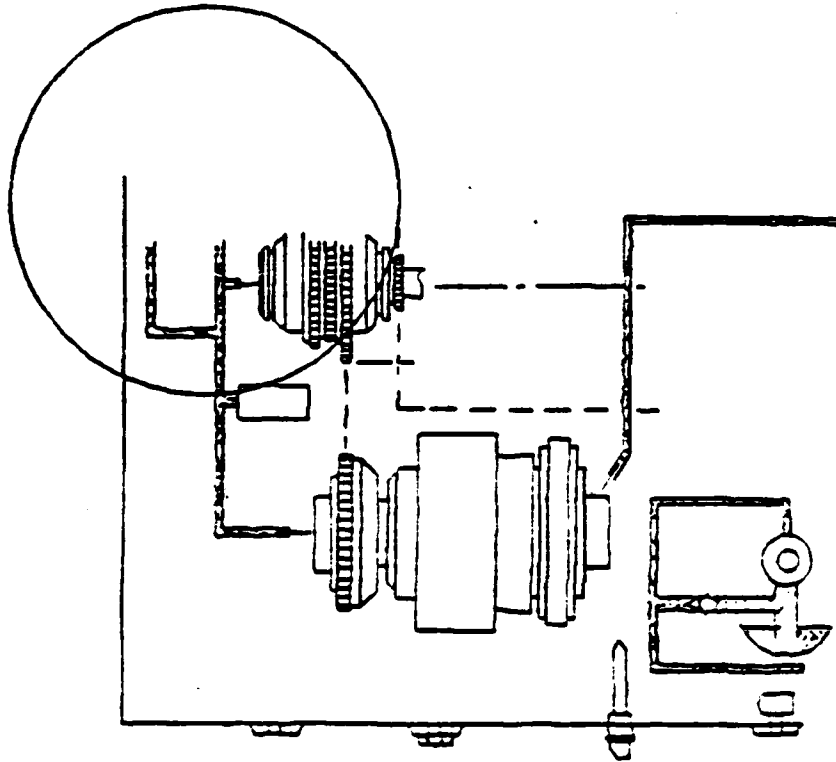

SYSSCAN, INC.  
WORDS USED: 12000  
VECTORIZED

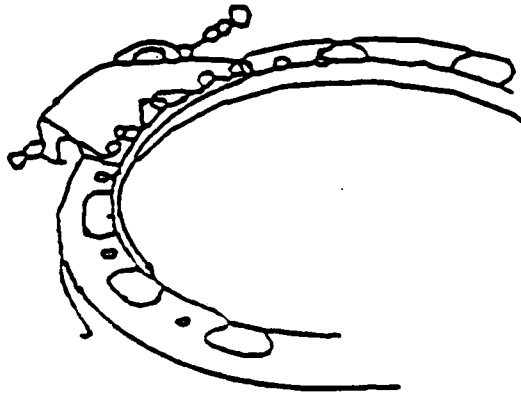

CIRCLED AREA  
ENLARGED  
200%

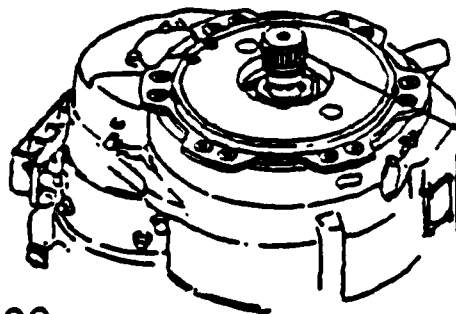
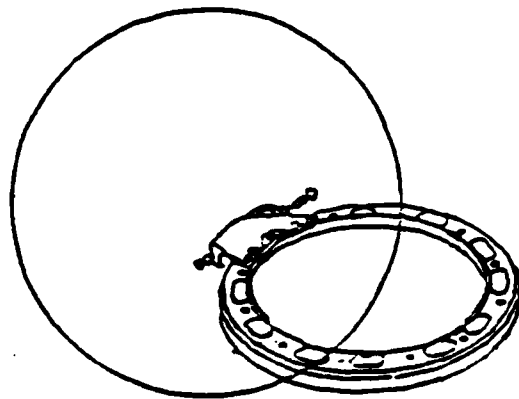

SYSSCAN, INC.  
WORDS USED: 16000  
VECTORIZED

TERMINAL  
BLOCK  
ASSEMBLY

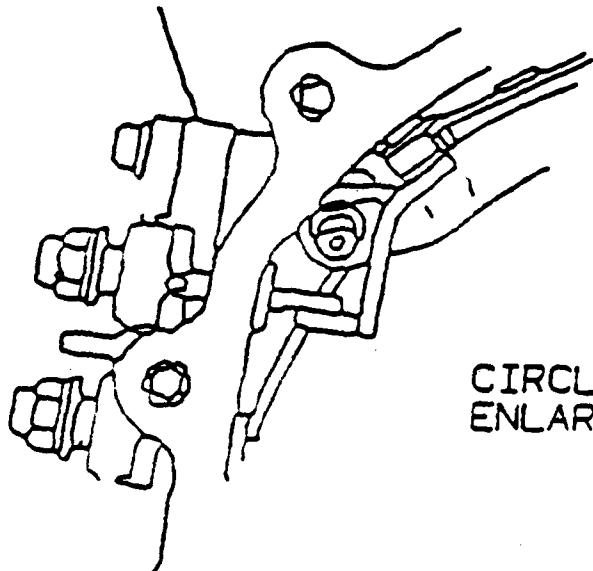

CIRCLED AREA  
ENLARGED 200%

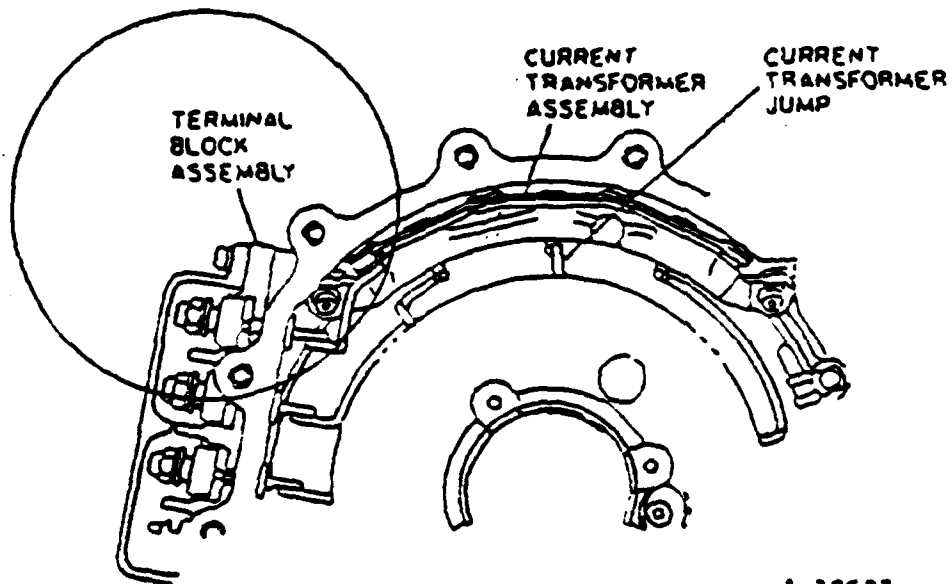

A-32637

GRAPHIC LABS, INC.  
WORDS USED: 16000  
VECTORIZED

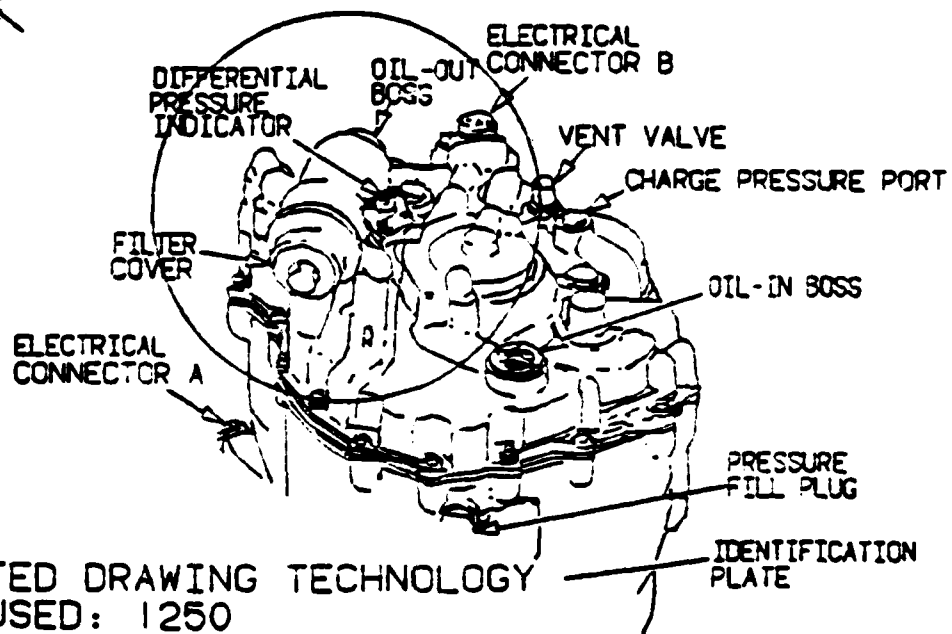
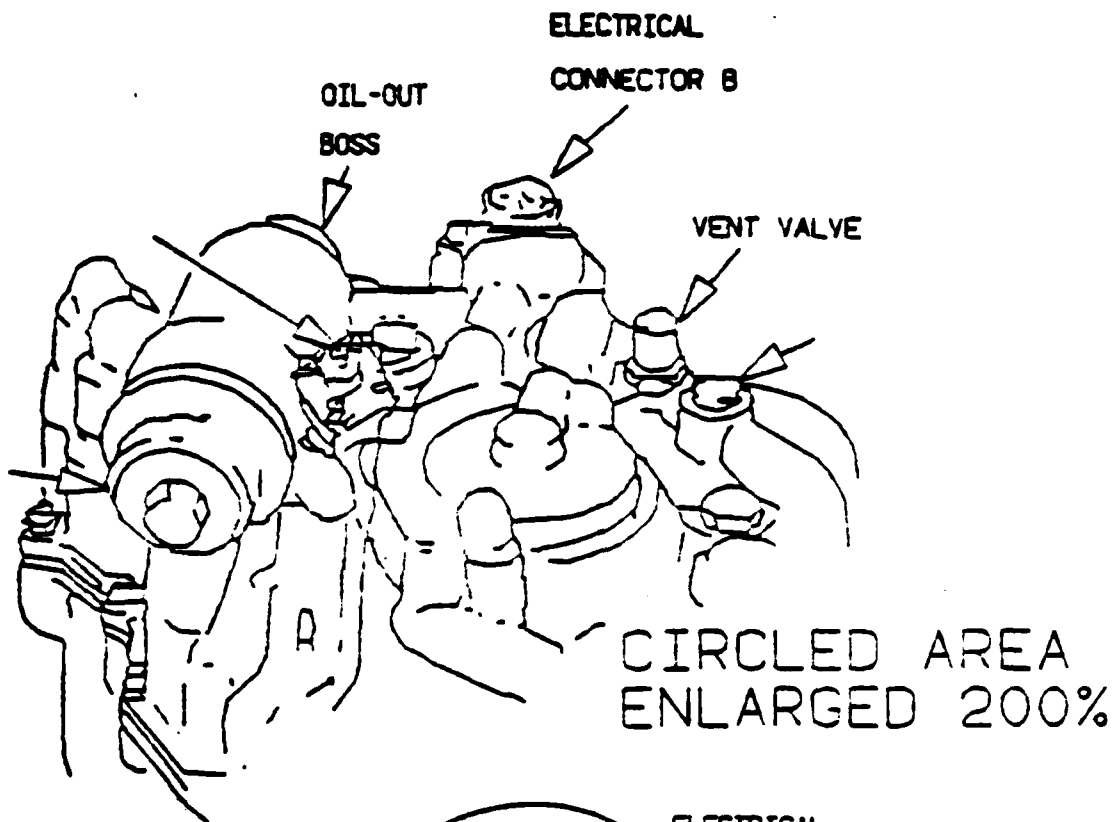

AUTOMATED DRAWING TECHNOLOGY  
 WORDS USED: 1250  
 VECTORIZED

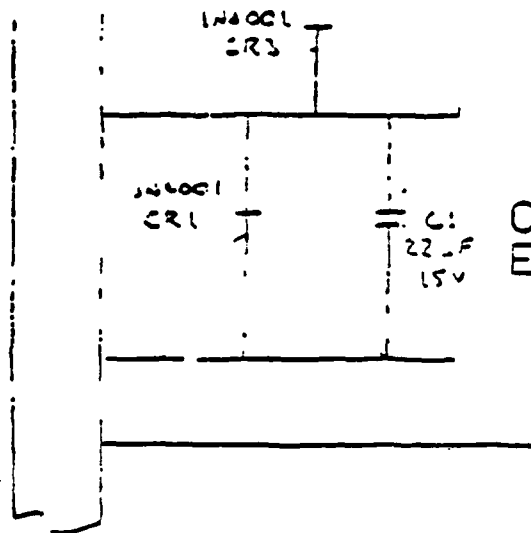

CIRCLED AREA  
ENLARGED 200%

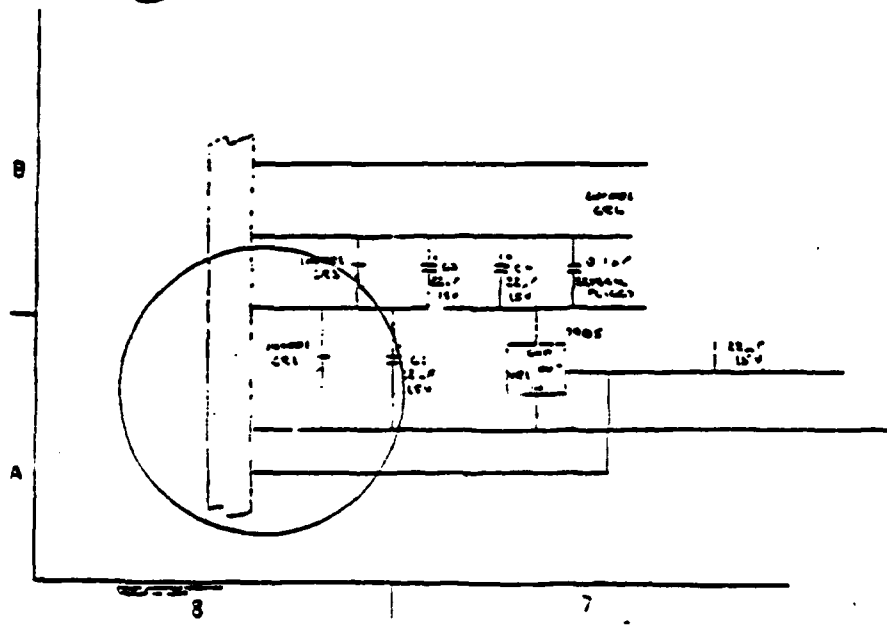

SYSSCAN, INC.  
WORDS USED: 9000  
VECTORIZED

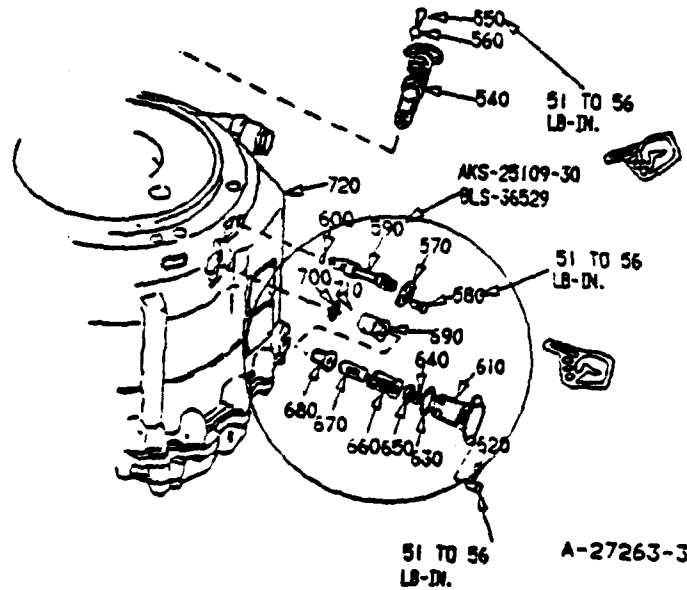
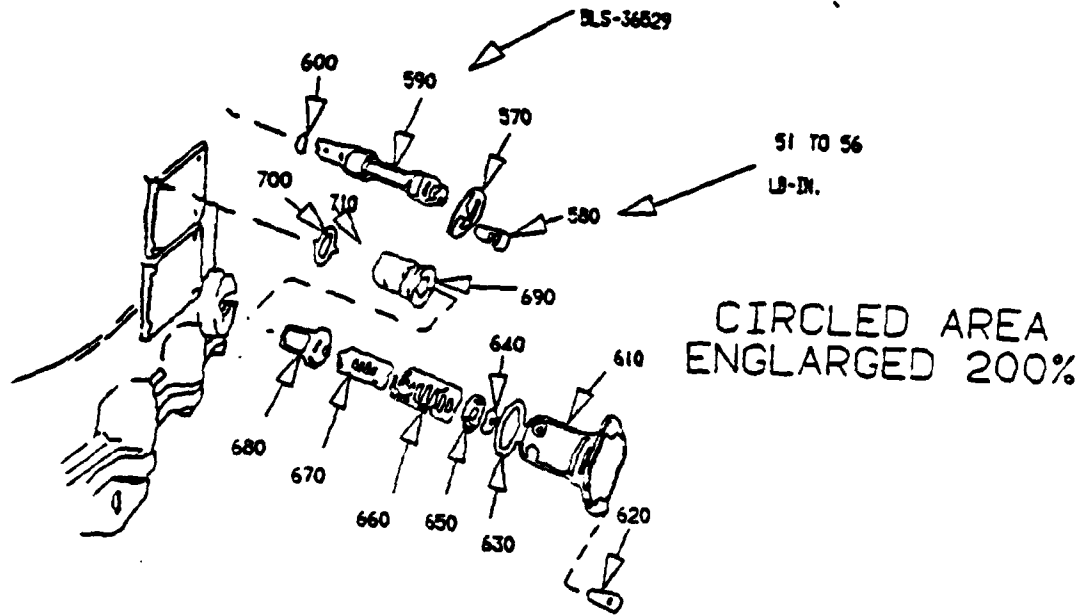

AUTOMATED DRAWING TECHNOLOGY  
 WORDS USED: 12000  
 VECTORIZED

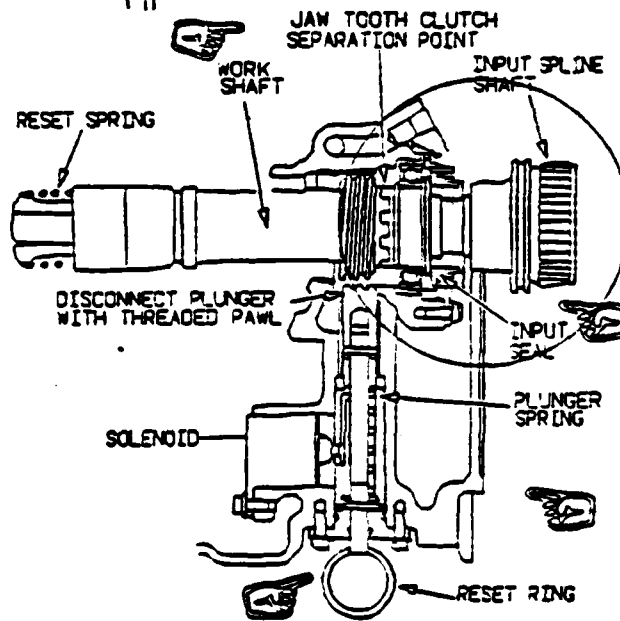
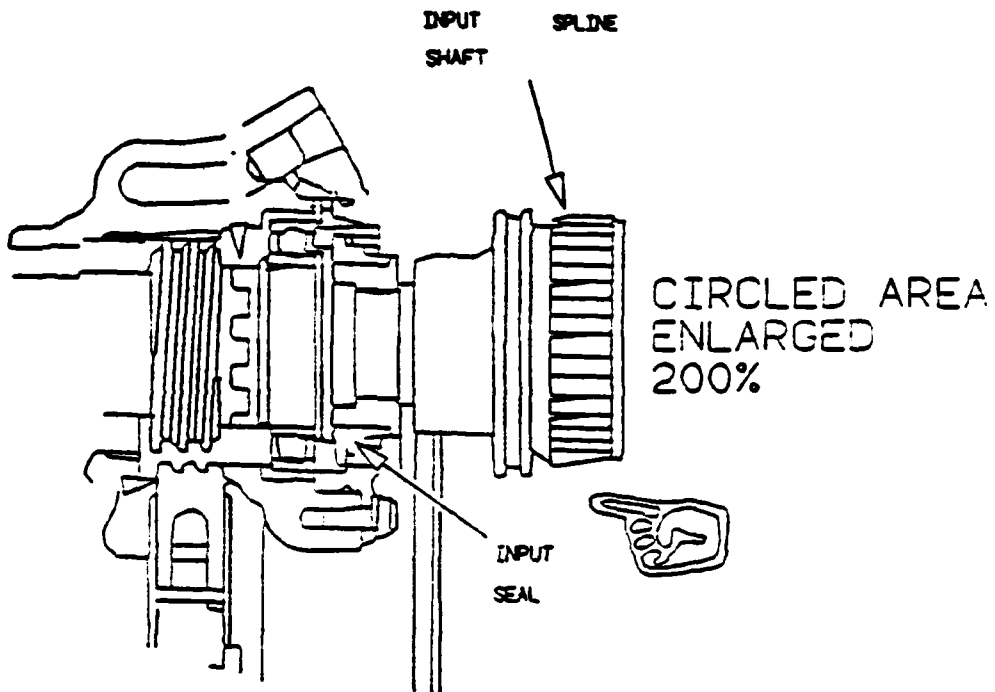

AUTOMATED DRAWING TECHNOLOGY  
 WORDS USED: 9897  
 VECTORIZED

A-31152-2

	J3	→	
	J3	→	37 > UNUSED
20	J3	→	36 > BTB LO TRIP A4AIJI-28 SH 20
21	J3	→	27 > BTB LO CLOSE A4AIJI-3 SH 20
22	J3	→	57 > DISC LAMP A4AIJI-29 SH 20
23	J3	→	28 > OP LAMP A4AIJI-2 SH 20
24	J3	→	58 > BTB ISOL/APU-U A4AIJI-7 SH 20
25	J3	→	29 > UNUSED

CIRCLED AREA  
ENLARGED 200%

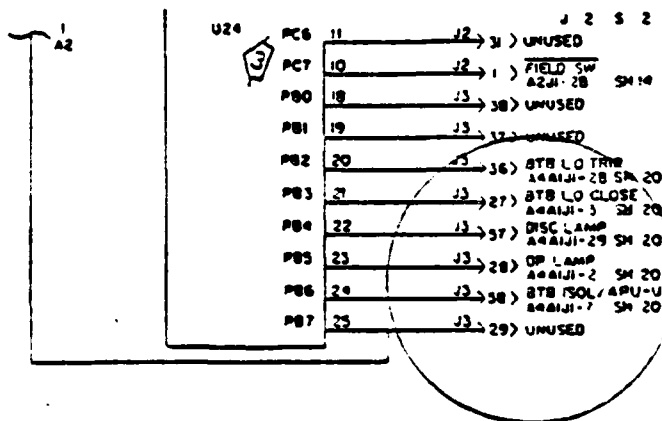

GRAPHIC LABS, INC.  
WORDS USED: 11000  
VECTORIZED

767 GCU  
DATA I/O  
SERIAL PORT

**APPENDIX C**  
**COST ANALYSIS OF TYPICAL AVIATION SQUADRON'S INITIAL**  
**OPTICAL HARDWARE AND SOFTWARE OUTFITTING AND**  
**DISTRIBUTION SAVINGS.**

This appendix will present an analysis and estimate of the initial outfitting costs of a representative aviation squadron transitioning to a CD-ROM optical media technical documentation environment. The initial outfitting cost estimation will include hardware costs for a CD-ROM optical workstation, software retrieval and indexing development costs, and CD-ROM disc mastering and replication costs. Additionally, mailing costs for both initial and revisional technical documentation of CD-ROM vs. paper distribution will be offered. The revisional comparison will include updating CD-ROM disc mastering and replication costs.

**INITIAL CD-ROM OUTFITTING COSTS:**

**WORKSTATION (HARDWARE) SET UP:**

(ASSUME SEVEN STATIONS PER SQUADRON)

- ZENITH - Z-248-10MB HARDDISK - 360K DISK DRIVE
- CD-ROM DISC DRIVE
- ZENITH COLOR MONITOR
- LASER PRINTER

=====

APPROXIMATE WORKSTATION GSA COST -- \$6,000.00

SEVEN STATIONS @ \$6,000 EA. ----- = \$42,000.00

**SOFTWARE / DISCS DEVELOPMENT COSTS:**

(ASSUME ONE OF TEN SQUADRONS

EA. SQDN USING 10 DISCS OF AN

ORIGINAL 500 REPLICATED OR .02 OF TOTAL

CD-ROM DISC TITLE DEVEL. COSTS)-.02 \* \$488,700.00 = \$ 9,775.00

=====

**TOTAL HARDWARE / SOFTWARE / DISC COSTS ----- = \$51,775.00**

# C D-ROM DATA PREPARATION COST ANALYSIS

## ASSUMPTIONS AND ISSUES:

- COMBINATION TEXT AND GRAPHICS DATABASE
  - (ASSUME 200 MB Total Database)
- GRAPHICS --
  - RASTER SCANNED
    - more data storage required
  - VECTOR REPRESENTATION
- TEXT --
  - HOW STORED?
    - DIGITIZED
    - NON -DIGITIZED :
      - CONVERSION VIA:
        - MANUAL RE-KEYING
        - SCANNED
- IF TEXT IN DIGITAL FORM:
  - WHAT TYPESETTING CODES?
    - SGML(ASSUME STANDARD)
- TARGET DISPLAY HARDWARE? (ASSUME MS-DOS PC)
- TURNAROUND TIME - PRIORITIES--(ASSUME 3 WEEKS)
- NUMBER OF DISC COPIES (ASSUME 500)
- UPDATE / REVISION CYCLE (ASSUME QUARTERLY)
- RETRIEVAL SOFTWARE - LICENSING AGREEMENTS

## COST COMPONENTS:

### ● SOFTWARE ISSUES / COSTS:

#### \* RETRIEVAL SOFTWARE LICENSE

--PER COPY ROYALTY = 500 @ \$275 EA. = \$137,500

--S/W CUSTOMIZATION REQ'D FEES:

----\$150 /HR (ASSUME 10 MANWEEKS = \$60,000)

●DATABASE ISSUES / COSTS:

\*DIGITIZATION: (ASSUME 500 PAGES / WEEK)  
(ASSUME 100,000 PAGES)

-- SCANNING COST = \$2.19 / PAGE = \$219,000

-- MANUAL RE-KEYING = \$5.16 / PAGE

(SEE APP. A - ENCL 2) = \$516,000

\*RASTER SCANNED STORAGE REQUIREMENT CONSIDERATIONS

\*GRAPHIC QUALITY OF RASTER TO VECTOR (LUS - SEE APP. B)

\*COMPRESSION/SEARCHABILITY OF DATA (ACCESS TIME REQ'MTS)

●INPUT FILTER DEVELOPMENT:

(CONVERSION TO STND. RECORD FORMAT -SRF- FOR KRS RETRIEVAL)

\*IN DIGITAL FORMAT -NON-STANDARD TYPING-CODES.

--\$150 HR DEVELOPING STRIPPING PROGRAM

--ASSUME 10 MAN. WEEKS @ \$150 HR = \$60,000

--STANDARD CODES - E SGM

--CODE VERIFICATION = \$2,000-5,000

●DATA PREPARATION:

(ASSUME DATA IN SRF - KRS FORMAT AND CONTRACT FOR ONE  
DATABASE TO BE UPDATED QUARTERLY)

\* INVERSION OF INDEXING = \$20 / MB , 200MB @\$20/ MB = \$4,000

---HIGH SIERRA STANDARD OUTPUT --TAPE READY FOR DISC

MASTERING FACILITY--(MOSTLY AUTOMATED INDEXING PROCESS)

●DISC MASTERING:

TURN-AROUND TIME DEPENDENT -- 21 DAYS = \$5,200

●DISC REPLICATION:

FACTOR OF TURN-AROUND /VOLUME- (21 DAYS, 500 COPIES)

500 DISCS @ \$6.00/DISC = \$3,000

● TOTAL CD-ROM DISC DEVELOPMENT AND REVISIONAL COSTS:

	INITIAL CD-ROM	CD-ROM REVISION
*****		
KRS Retrieval Software License	\$137,500.00	-0-
--(option of: cpu time 500 discs @ \$275/copy or 10 CD-ROM titles 500 copies ea. @ \$20 /disc)		
Retrieval Development	\$ 60,000.00	-0-
--(with customized prep.)		
Optical Scanning	\$219,000.00	-0-
---(assume of 100,000 pgs.)		
Input Filter Development	\$ 60,000.00	-0-
---(assume non-SGML)		
Data Preparation	\$ 4,000.00	\$4,000.00
Mastering (21 day turnaround)	\$ 5,200.00	\$4,400.00
Replicas (500 at \$6 each)	\$ 3,000.00	\$2,500.00
=====		
TOTAL.....	\$488,700.00	\$10,900.00
TOTAL (assuming data submitted in a digitized, SGML format)...	\$154,700.00	\$10,900.00

**MAILING COST COMPARISON  
OF 540MB OF DATA  
SHIPPED BY DIFFERENT MEDIA**

**ASSUMPTIONS (SEE FIGURE 5.3):**

- ALL MEDIA ARE SHIPPED TO A SINGLE LOCATION
- COST DETERMINED FOR SHIPMENT FROM WASHINGTON, D.C. TO SAN DIEGO, CA.
- ALL MEDIA SENT BY ONE CONTAINER EXCEPT THE PAPER BASED MANUALS WHICH ARE SHIPPED INDIVIDUALLY AS 500 PAGE BOOKS.
- AN INITIAL SQUADRON TECHNICAL DOCUMENTATION PACKAGE CONSISTS OF 270,000 PAGES OR 540MB OF DATA
- A REVISION CONSISTS OF A 10 MANUAL CHANGE; EACH MANUAL CONSISTING OF 1000 PAGES.; TOTAL PG.CHANGE = 10,000

**CD-ROM INITIAL ISSUE MAILING COST SAVINGS OVER :**

PAPER -(270,000 PAGES)	=	\$4135.71
FLOPPY DISKS (1500 DISKS)	=	\$ 55.41
MAGNETIC TAPE (13 TAPES)	=	\$ 29.17
MICROFICHE (1000 PRINTS)	=	\$ 10.00

**CD-ROM REVISION MAILING COST SAVINGS OVER :**

PAPER (10,000 PAGES)	=	\$ 153.00
FLOPPY DISKS.(55 DISKS)	=	\$ 2.08
MAGNETIC TAPE (.5 OR ONE)	=	\$ 2.30
MICROFICHE (37 PRINTS)	=	\$ .37

**APPENDIX D**  
**EXAMPLE WORKSTATION SCREENDUMP PRINT-OUTS OF BOEING**  
**757 CD-ROM MAINTENANCE MANUAL**

This appendix consists of a user's introduction depicting the screen display progression of the graphic retrieval system developed by KnowledgeSet. The screen graphic illustrations are followed by a marketing newsletter or information bulletin explaining the text and graphic software retrieval system. Published by the KnowledgeSet Corporation, this literature includes a command summary of the screen display progression. Finally, reproduced examples of the hardcopy laser print-outs or screen dumps of a simulated maintenance action utilizing the BOEING 757 CD-ROM Maintenance Manual concludes Appendix D and this research paper.

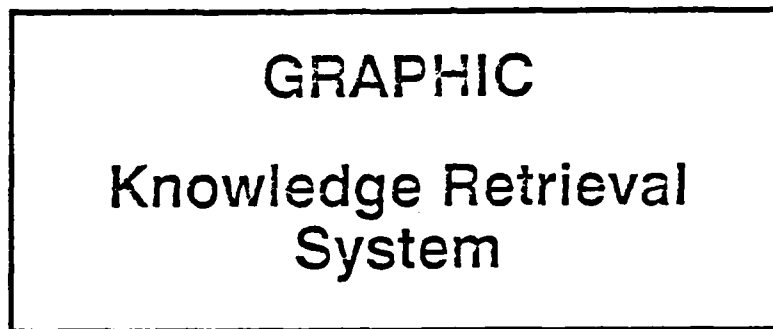

**COMPUTER SCREEN**  
**INTERFACE**

**SEPTEMBER 1987**

KnowledgeSet Corporation  
60 Garden Court Suite 310  
Monterey, CA 93940  
(408) 375-2638

COPYRIGHT (c) 1987 KnowledgeSet Corporation Monterey, CA  
ALL RIGHTS RESERVED

Function Text Graphics Bookmarks Preferences

KRSGEM

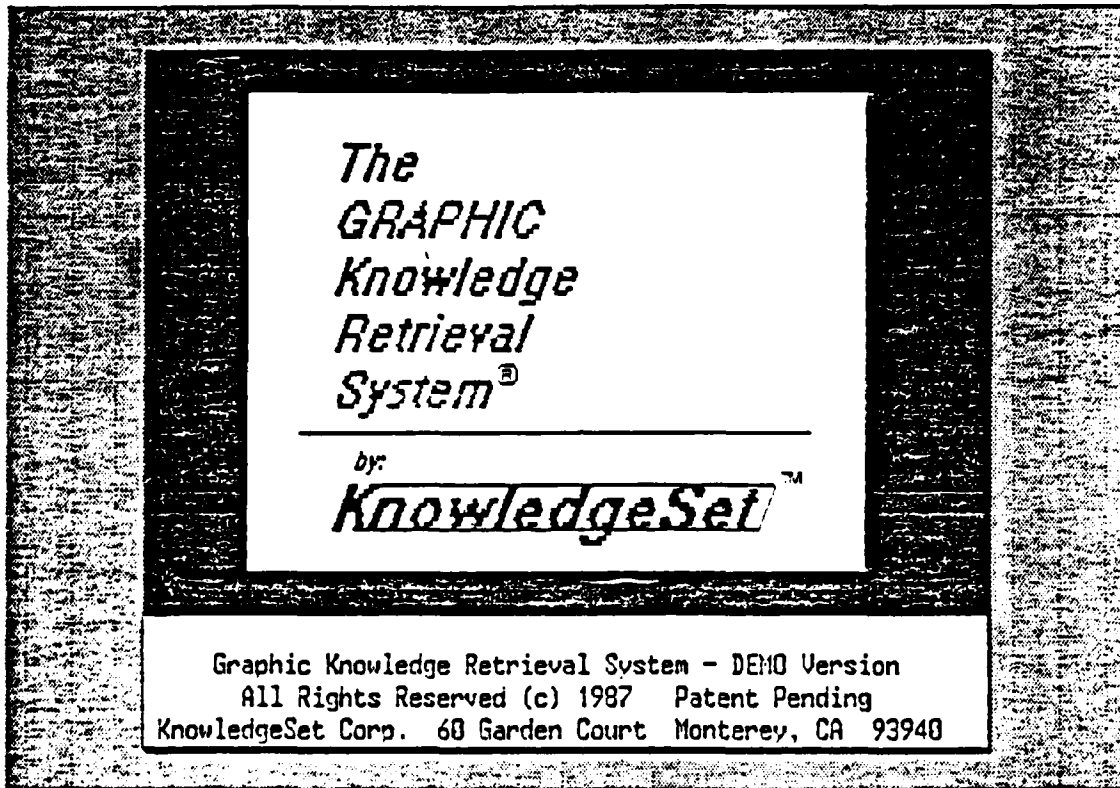

## Graphic KRS Title Screen

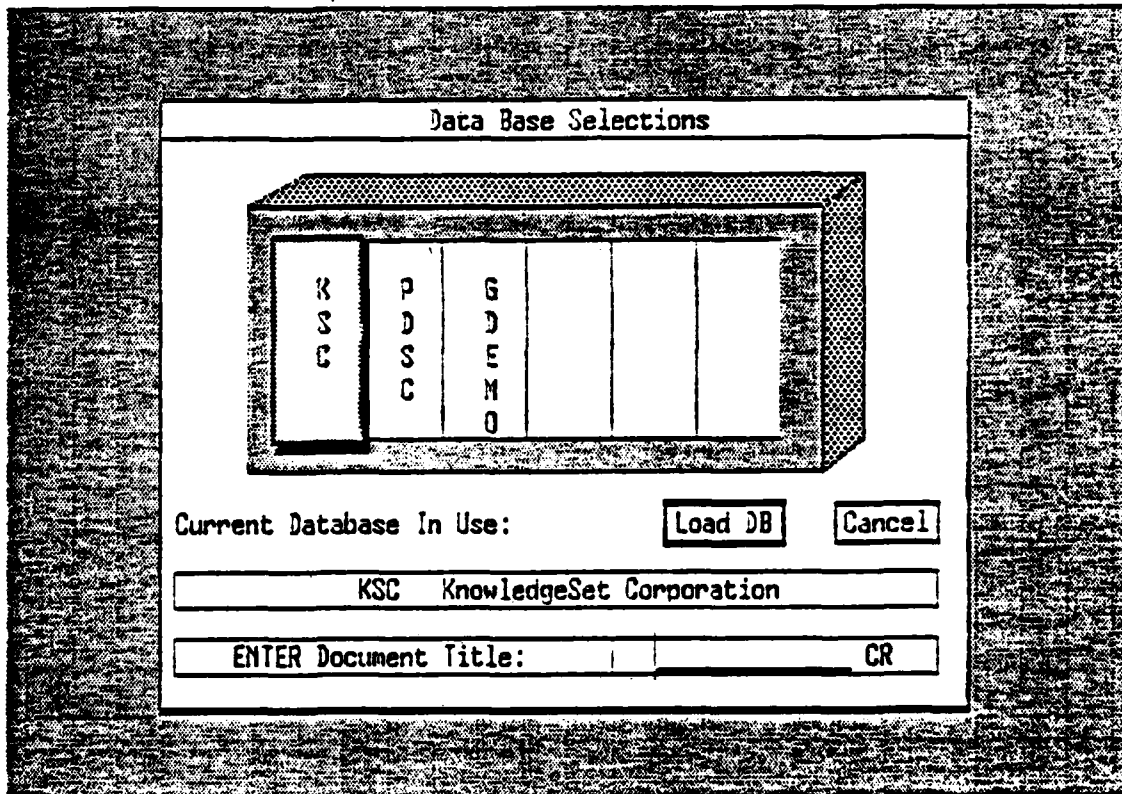

Database Selection Screen

Function	Text	Graphics	Bookmarks	Preferences	KRSGEM
✕	Table of Contents				◆
	KnowledgeSet Demo: Contents				▲
	<p><b>KNOWLEDGESET CORPORATION</b></p> <p>           CD-ROM Optical Publishing Technology            CD-ROM Software Development Services            The Knowledge Retrieval System            Optional Knowledge Retrieval System Features            KRSG Video Demonstration            Video Production Services            KnowledgeSet Corporation Office         </p>				
	Prev Title	Next Title ^N	View Titles ESC		▼

## Table of Contents Screen

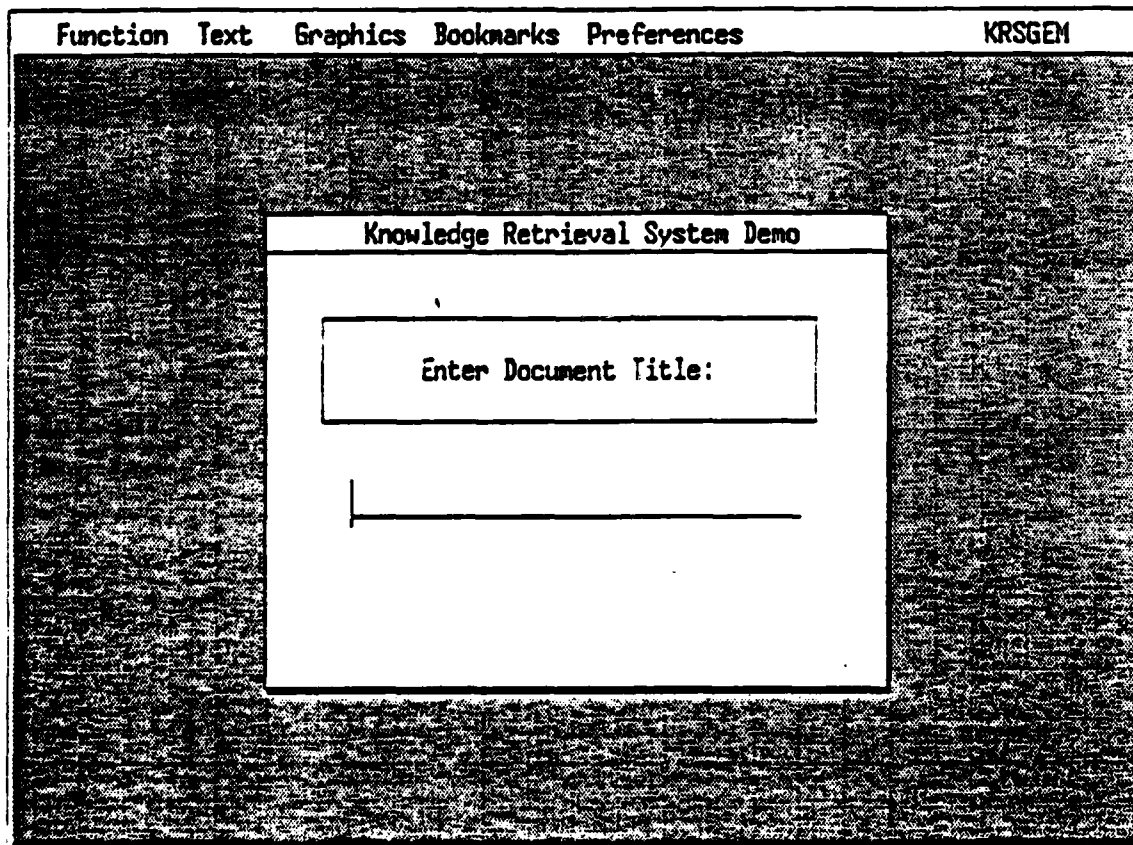

## Heading Finder Screen

Function	Text	Graphics	Bookmarks	Preferences	KRSDEM
Word Search					
Search Categories Document Titles Bibliographies Foot Notes Tables Document Text <b>ALL Categories</b>	There are 0 occurrences in 0 documents of:	Word Relationship In same Document <del>In same paragraph</del> Exact order 1 - 10 words apart 1 - 50 words apart 1 - 100 words apart			
The words _____ along with _____ along with _____ along with _____ along with _____					
Search	Display	Clr Qry	Save Query	Load Query	

## Word Search Screen

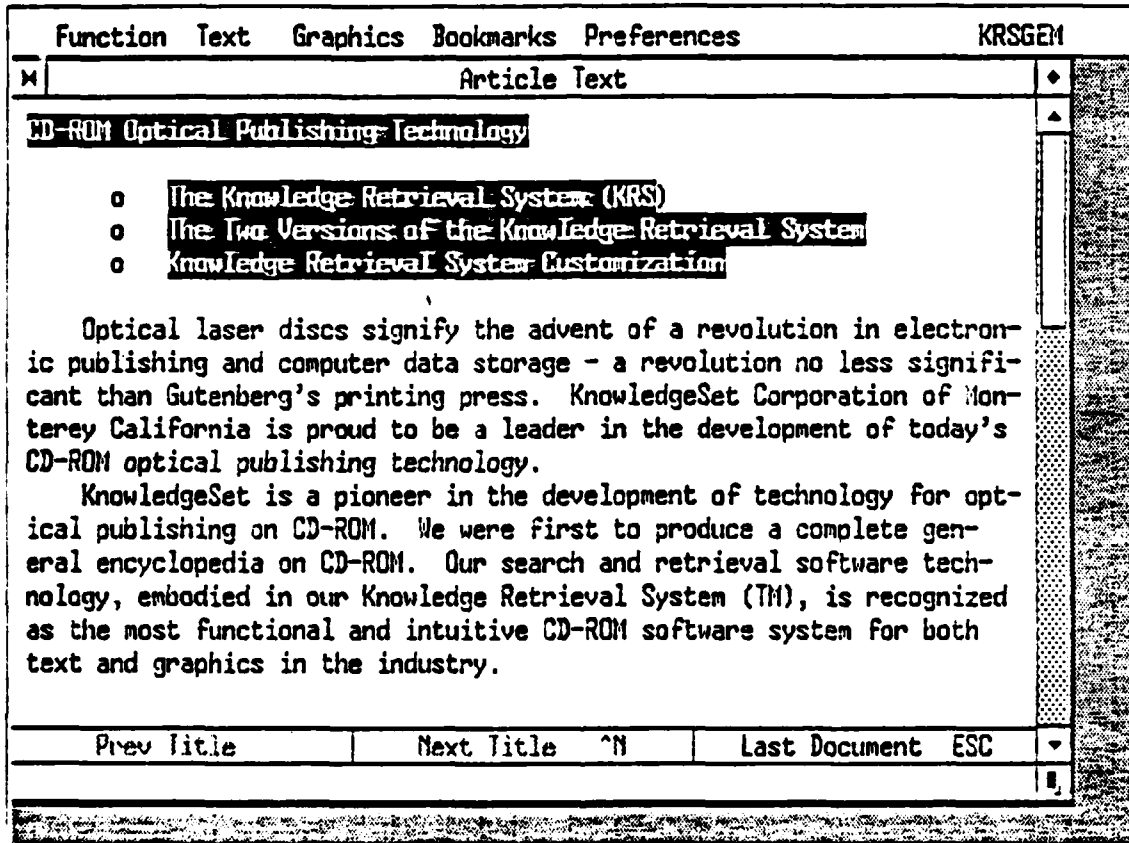

## Text Display Screen

Function Text Graphics Bookmarks Preferences KRSGEM

Article Text

Graphics Demonstration

Vector Graphic Examples  
 The vector graphic  
 The following vector gr  
 style, line width, text

Vector Figure: 1  
 Vector Figure: 2  
 Vector Figure: 3

Vector Graphic Test Fig  
 The following vecto  
 the Graphic Knowledge R  
 hardware. The test fig  
 o An 8 X 10 in  
 be displayed.

Figure

SOLENOID VALVE

ELECTROHYDRAULIC SERVO VALVE

ELECTRICAL CONNECTOR

SYSTEM RETURN

SYSTEM PRESSURE

FILTER

ACTUATOR PISTON

Prev Title      Next Title ^N      Last Document ESC

## Graphic Display Over Text

# THE KNOWLEDGE RETRIEVAL SYSTEM by KnowledgeSet Corporation

The Knowledge Retrieval System (KRS) is a complete CD-ROM search and retrieval software system specifically designed for use with optical media. There are two versions of the KRS each designed for different database applications. The Text KRS is designed for databases consisting of only text information. The Graphic KRS is designed for databases that combine text and graphic information.

The KRS has been engineered to simplify customization for any database application. The two main components of the KRS, the User Interface and the Retrieval Engine, are separate modules. The Retrieval Engine consists of the fundamental search and retrieval routines necessary in every database application. The User Interface is the software link between the Retrieval Engine and the person using the KRS. It is the screen display and specific query structure required by a specific database application. This modular design enables software engineers to customize the KRS for virtually any database search and retrieval application.

## THE TEXT KNOWLEDGE RETREIVAL SYSTEM

The Text Knowledge Retrieval System (TKRS) is specifically designed for "text-only" databases. It is considered one of the easiest CD-ROM search and retrieval systems to learn and use. The Text KRS has a variety of outstanding features that enhance the "knowledge value" of any text-only database. Those features include:

### Standard Text KRS CD-ROM Software Features:

#### 1) Full-Text Word Searching

The KRS can find every occurrence of any word in a CD-ROM database that has been designed for KRS use. Each word is individually indexed so that only two access commands to the CD-ROM drive are issued by the KRS; one to find the word in the directory and the other to locate it on the disc. This design makes the search and retrieval access speed very fast. Speed is very important when searching through millions of words.

#### 2) Topic Searching or Browsing

You can "browse" through a database by searching for document titles or title fragments. For example, to find information on optical media in a CD-ROM database disc consisting of Fortune 1000 company newsletters, you could enter the term "optical

media" using the Topic Search function. The KRS displays the list of titles from the database beginning with the closest alphabetical match to the term "optical media".

### 3) Multiple Word Search Specifications

Searching for two or more different words enables you to search for information based on criteria setup through word relationships. The KRS provides the following "operators" to specify different word relationship options:

*Adjacency* - Adjacency refers to words that occur next to each other such as in a phrase or proper name such as "internal revenue" or "Albert Einstein". The words can occur in any order provided they are adjacent.

*Alternates* - Alternate word specifications enable you to search for different but related terms. In searching for a term such as "farming", it might be advisable to search for the related term "agriculture". Searching for one of the terms could limit the amount of useful information found on the subject.

*Association* - Association refers to words that are referenced together within a specified span of text. The words may or may not be related contextually.

*Negation* - Negation enables you to specify an exclusion criterion for a secondary search term. In other words, you can search exclusively for all references to a primary search term that are not referenced with a secondary term. To find all references to "Martin Luther" exclusive of "Martin Luther King", you could negate "king" as a secondary term.

*Truncation* - Truncation enables you to simultaneously search for a specific word with all its possible suffixes. Two special characters, the question mark and the asterisk, serve as ambiguous place holders in a search specification. Enter the specification "horse?" to find all references to "horse" and "horses". Enter "financ\*" to find all references to "finance", "finances", "financial", "financing", "financed", "financier", "financiers", etc.

*Intermediate Words* - intermediate words are words that occur between what would ordinarily be adjacent words such as in proper names. A period serves as an ambiguous placeholder for an intermediate word in the search specification. If you search for "John Kennedy" as adjacent words, the KRS would not find references to "John Fitzgerald Kennedy" or "John F. Kennedy". You must enter "John.Kennedy" to find all the references.

#### 4) Word Proximity Search Specifications

You can specify search criteria that requires search terms to appear in the the searched words must appear in exact order as specified or that the terms appear within a given number of words apart (ranging from 1 to 999 words). For example, you can search exclusively for references to "astronomy" and "telescope" within 25 words of each other in the text.

#### 5) Restricted Field Search Specifications

To speed the searching process, a search can be limited to certain fields in the database. For example, a word search in an encyclopedia database can be limited to bibliographies. A search through a database of electrical components can be restricted to a section listing integrated circuits.

#### 6) Function Key Menu

All KRS commands are issued through the function keys making the KRS very easy to learn. A function key diagram is displayed on screen at all times to let you know the commands you have available. In addition, the function keys are redefined for different purposes at each level of the program. For example, at the list of document titles, function keys F3 and F4 select commands to move backwards and forwards respectively through the list of titles. At the text display level, function keys F3 and F4 select commands to move backwards and forwards respectively through the text.

#### 7) Spill File Storage

A spill file provides a temporary storage area on magnetic disk enabling you to capture large, complex search results where the resulting information "spills" over from or fills the RAM memory of the computer. This means that the computer RAM memory size does not place a limit on the complexity or size of a search result.

#### 8) Query Storage

You can save a KRS search specification to magnetic disk file for later use. This capability expedites the entry of complex or frequently used search specifications.

#### 9) Printer or Disk Output

Information retrieved from a CD-ROM database can be stored in a magnetic disk file for use with a word processor or sent to a printer for hard copy output. The output format for printing is easily controlled in the KRS. Options include page breaks, page

length, left margin setting, form feed, single or double line space, line length, right justification, and hyphenation.

#### 10) Screen Display Format Options

Display format options allow you to control the look of the KRS screens and to modify them to your own taste. Options include single or double spaced text, line length, right justification of text, and hyphenation. Options are selected with the function keys. You can also reposition the function key diagram to the left side of the screen display or to the bottom of the screen.

#### 11) Look-up Word Function

The Look-up Word function provides access to the CD-ROM database word index. This can be useful to check on the spelling of a word or to find out how many times a word appears in the database.

#### 12) Document Outline

Outlines enable you to access an article by headings and subheadings. This is especially useful for long articles and documents eliminating the tedious paging process for finding a specific place in a document.

#### 13) Portability

The KRS has been engineered in the C programming language with certain machine dependent modules programmed in the appropriate assembly language. The KRS can be distributed on floppy disk or it can be mastered on the CD-ROM disc with the corresponding database. The KRS occupies 210 kilobytes of space. Porting of the KRS to other operating systems and microprocessors is a definite plan for the future. The KRS currently operates under MS-DOS and the 8086 series of microcomputers.

#### 14) Data Encryption

Any CD-ROM disc prepared and mastered for the KRS can be specially encoded to help prevent copyright infringement, copying, or other unauthorized access to the data.

## 15) Text Display Features

You can move through the text of a document in the database with the following functions: scroll text in either direction, view next full screen of text, view previous full screen of text, view first full screen of text, view next article or document, view previous article or document, view article outline and access article or document by heading and subheading.

The following three features are designed to maximize access to strong information linkages within a database. These features are only available for databases that have been specifically prepared for this type of data access.

*Citations (Cited by)* - Citations provide you with a list of all document titles in the database that refer through crossreferences to the document you are currently viewing. You can access any title in the list directly.

*References (Refers to)* - References provide you with a list of all document titles in the database that the document you are currently viewing refers to through crossreferences. You can access any title in the list directly.

*Expert View* - Expert View provides you with a list of document titles, both references and citations, that are most closely related to the document you are currently viewing. The documents are listed in descending order with those most closely related to the current document at the top of the list and those less related towards the end of the list. Expert View is the result of a uniquely designed KnowledgeSet heuristic that discovers other documents that are closely related topics.

## THE GRAPHIC KNOWLEDGE RETRIEVAL SYSTEM

KnowledgeSet's Graphic KRS is an innovative, easy to use search and retrieval software system designed for databases that consist of both text and graphics. The Graphic KRS offers many advanced features including independent graphics support for bit mapped, scanned image, and vector graphic display. These capabilities make the Graphic KRS ideal for technical publications, service manuals, parts catalogs, and other special reference materials that require graphic images.

### Standard Graphic KRS CD-ROM Software Features:

#### 1) Vector and Bit Mapped Graphics

Graphic capability is a major factor in establishing the value of CD-ROM technology. Graphic images stored on a CD-ROM along with text information can be retrieved and displayed using the Graphic KRS. The Graphic KRS supports RLE (run length encoded) images and CIITT Group IV bit mapped images.

#### 2) Icons, Windows, and the Mouse

The Graphic KRS runs as an application under GEM (Graphics Environment Manager) from Digital Research. All commands are issued to the Graphic KRS using a mouse to manipulate various screen display items such as icons, windows, and drop down menus. Using graphic window functionality, the Graphic KRS displays both text and graphics simultaneously. Text and graphics can be scrolled within a window border.

#### 3) Zooming and Panning of Graphic Images

The Graphic KRS can zoom in and out on vector images. This provides the display versatility required for highly complex images such as CAD/CAM technical drawings and schematics. Image panning enables a complete image to be scanned within a small window allowing the simultaneous display of text and graphics. Panning is available for both vector and bit mapped images.

#### 4) Bookmarks

The Graphic KRS Bookmark capability enables you to place "electronic" bookmarks at various places in a CD-ROM database. Throughout a search session you can directly access any of the marked documents in the database. In addition, the Graphic KRS provides an automatic bookmarking feature that automatically places a mark at every document you access during a search session.

## **Optional Knowledge Retrieval System Features**

### **1) Field Specific Searching - (Text KRS only)**

Field specific searching enables you to search several fields or types of data simultaneously or exclusively with full Boolean operations within each field. For example, in a CD-ROM telephone directory you can specify a search for a name such as "Bower" in the names field excluding the streets field and cities field.

### **2) Custom Screen Design (Text and Graphic KRS)**

KnowledgeSet will customize the KRS screen display to the specific requirements of the client and the application.

### **3) Output Templates**

KnowledgeSet can implement custom data output templates for specific applications. The templates are designed jointly by the client and the KnowledgeSet technical staff.

### **4) Dynamic Crossreferences (Hot Links)**

Dynamic crossreferences are direct links to related documents or articles in the database. In the text, a crossreference appears as a word in reverse video. When you select a crossreference on screen, using the mouse, the Graphic KRS immediately displays the crossreferenced article.

### **5) On line Help System (Text KRS only)**

The KRS On-line Help System provides instant information to the user on KRS functions and procedures. Help is available at any level of the KRS with a simple press of a function key. At any time during a search session, you can press the "Help" function key. The KRS immediately provides instructions on all the active functions. The system serves as an on-line KRS reference manual which can vastly expedite user questions. The On-line Help System can be customized for specific application requirements.

### **6) Gold Key**

The KRS Gold Key enables you to run another software application such as a wordprocessor from the KRS. When you finish using the other application the KRS returns to the place you left off.

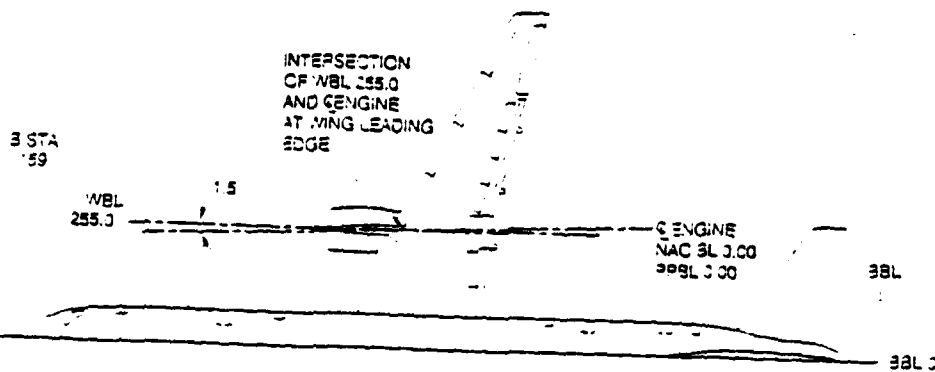
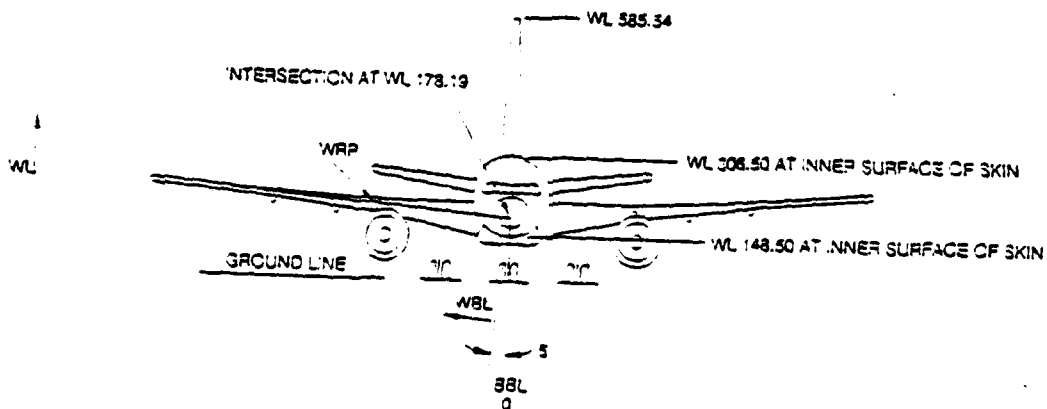
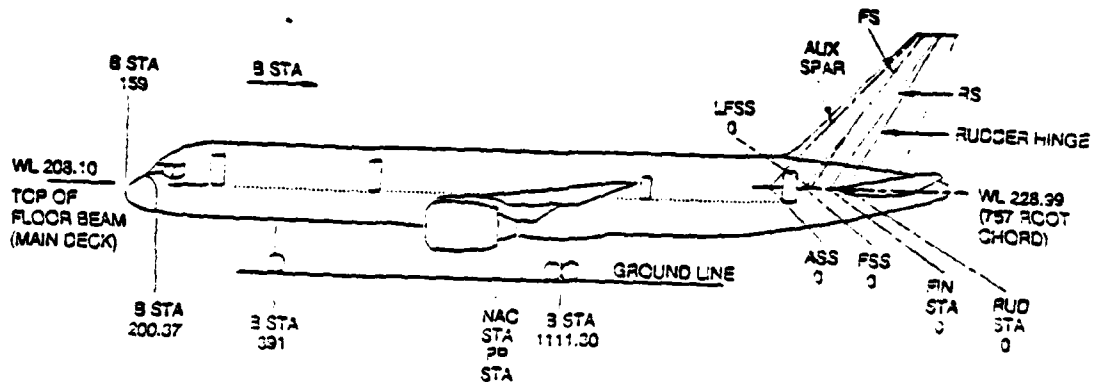

Reference Planes and Lines  
Figure 1 (Sheet 1)

48087

### GENERATOR DRIVE SYSTEM

COMPONENT	FIG. 102 SHT	QTY	ACCESS/AREA	REFERENCE
CIRCUIT BREAKERS	1		FLT COMPT, P6	
GEN CONT UNIT L, C304		1	681	•
GEN CONT UNIT R, C305		1	682	•
GEN DRIVE DISC L, C307		1	685	•
GEN DRIVE DISC R, C308		1	686	•
COUPLING - QUICK ATTACH/DETACH	2	2	413AL, 423AL FAN CCWL PANELS ACCESSORY GEARBOX	24-11-03
EXCHANGER - IOG AIR/OIL HEAT	2	2	413AL, 423AL FAN CCWL PANELS	24-11-04
GENERATOR - INTEGRATED DRIVE	2	2	413AL, 423AL FAN CCWL PANELS ACCESSORY GEARBOX	24-11-01

\* SEE WM EQUIPMENT LIST

Component Index  
Figure 101

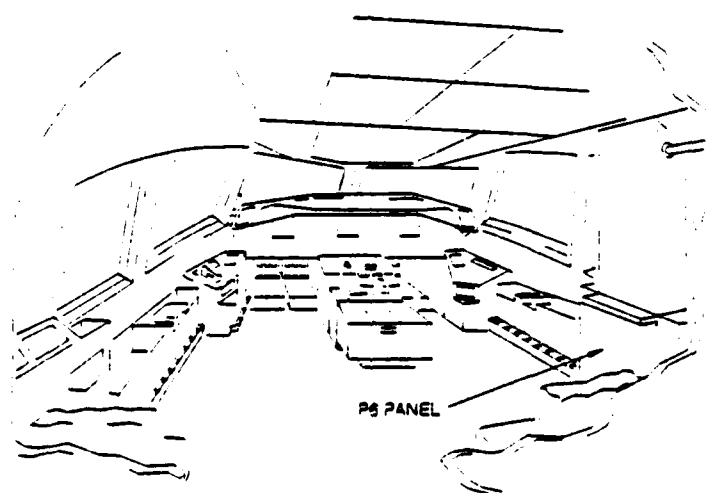

FLT COMPT

Component Location  
Figure 102 (Sheet 1)

387-9

(Abstracts): Screen Page Print  
Date: Jun 22/87 10:24  
4M/57 24-11-01-4: INTEGRATED DRIVE GENERATOR - REMOVAL/INSTALLATION

5. Remove Integrated Drive Generator ( Fig. 401 Sht. 1 , Fig. 401 Sht. 2 )
  - A. Open L and R GEN DRIVE DISC circuit breakers (6B5, 6B6) on main power distribution pane
  - B. Attach TO HOT-CLASSE Identifier.
  - C. Open fan cowl panels (Ref MM757 71-11-04).
  - D. Place container under IDG to catch oil.
  - E. Remove dust cover from overflow drain coupling.

**WARNING:**  
WHEN CONNECTING HOSE TO OVERFLOW DRAIN COUPLING, USE HAG AROUND FITTING TO PREVENT SPLASH I  
TO PRESSURE BUILDUP IN IDG CASE. HOT OIL CAN CAUSE INJURY TO PERSONNEL.

E. Depressurize IDG by connecting oil-drain hose to overflow drain coupling. Allow any oi  
training through oil-drain hose to flow into container. Keep hose below level of IDG.

**NOTE:**

It is normal for some oil to drain when the hose is connected to the coupling.

F. Remove lockwire from case drain plug.

**WARNING:**

USE EXTREME CARE WHEN DRAINING IDG OIL. WEAR SPLASH GOGGLES, INSULATED GLOVES, AND  
PROTECTION GEAR. CONTACT WITH HOT OIL CAN CAUSE SERIOUS INJURY.

G. Remove case drain plug (8) and O-ring (7). Allow oil to flow from IDG into container.  
Discard O-ring.

H. Disconnect oil-drain hose from overflow drain coupling.

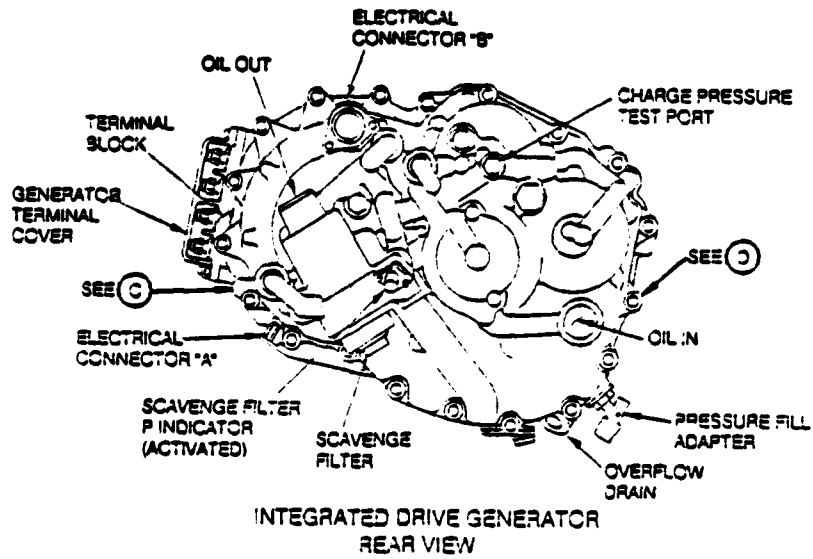

(B)

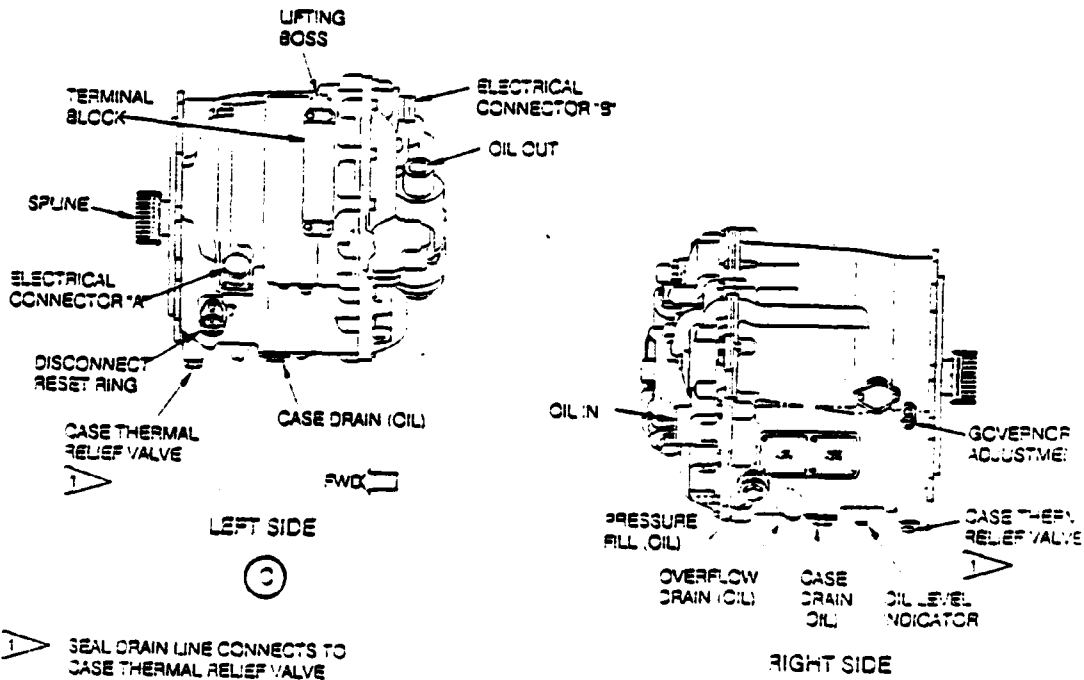

Generator Drive System Component Location  
Figure 1 (Sheet 2)

98023

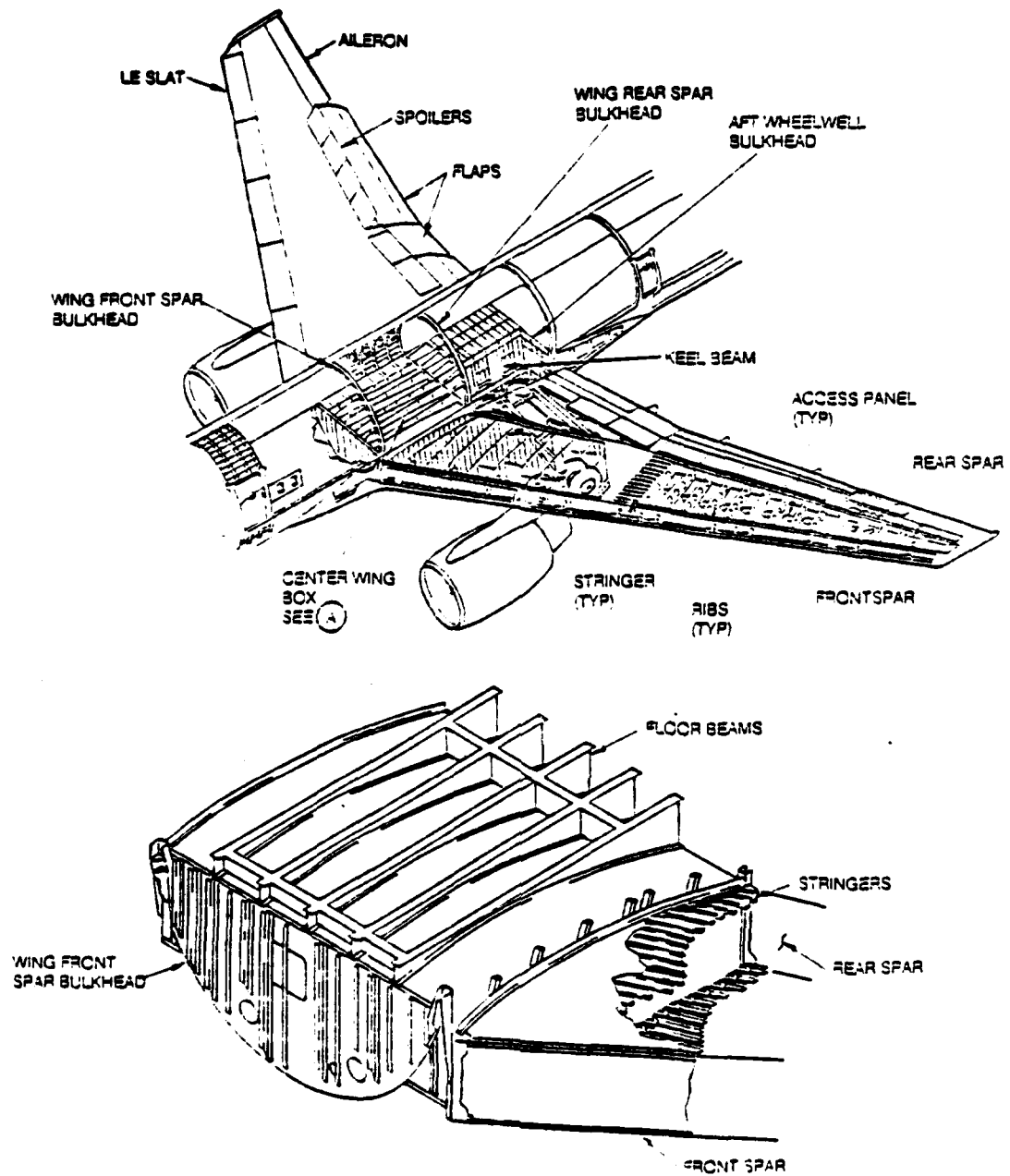

NOTE. RIGHT SIDE SPOILERS, AND FLAPS ARE SHOWN EXTENDED

(A)

Wing Structure  
Figure 1

28575

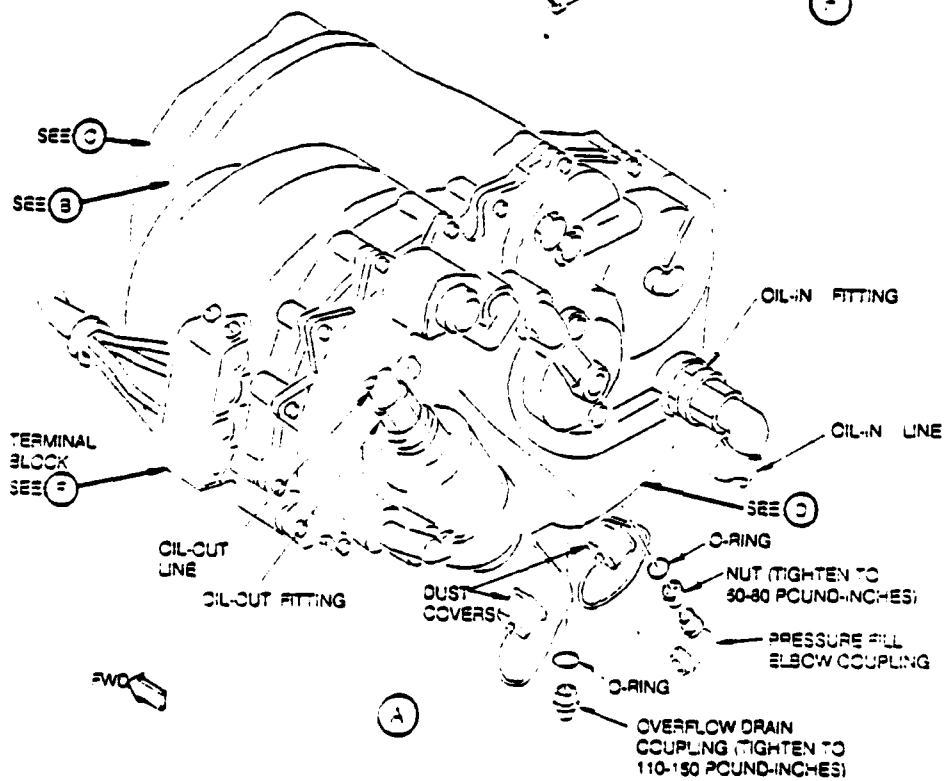
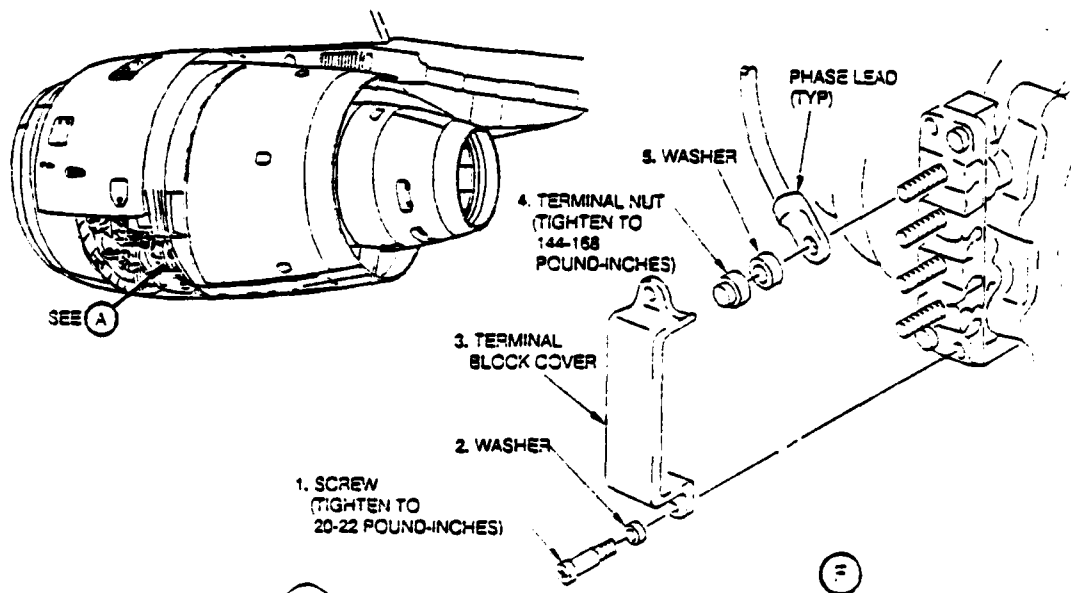

Integrated Drive Generator Installation  
Figure 401 (Sheet 1)

98423

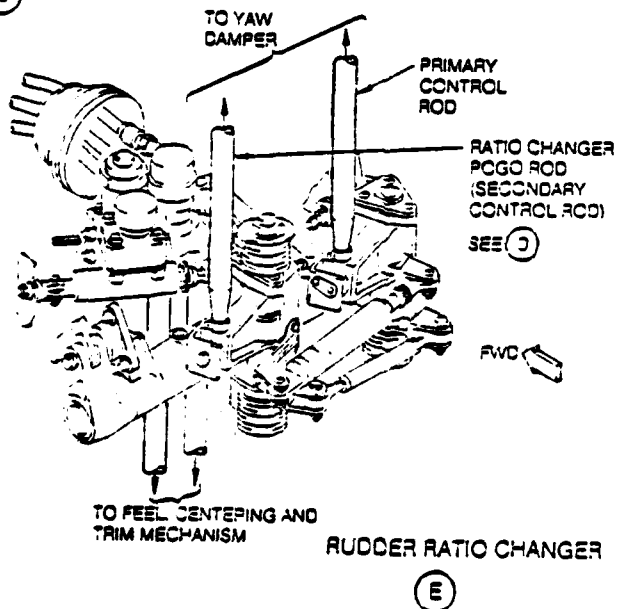
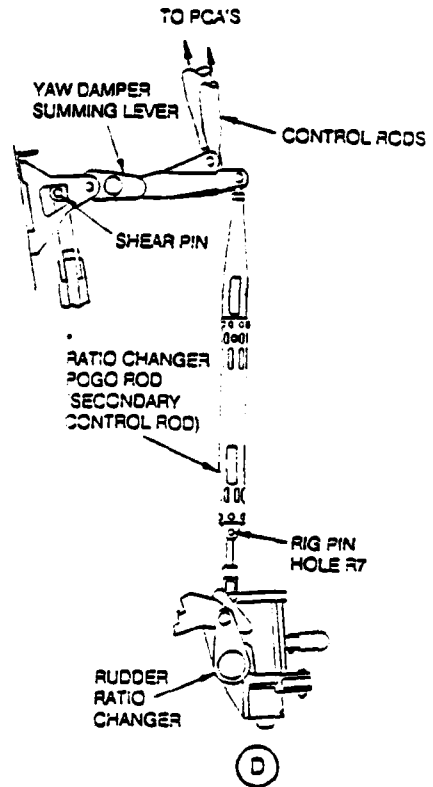
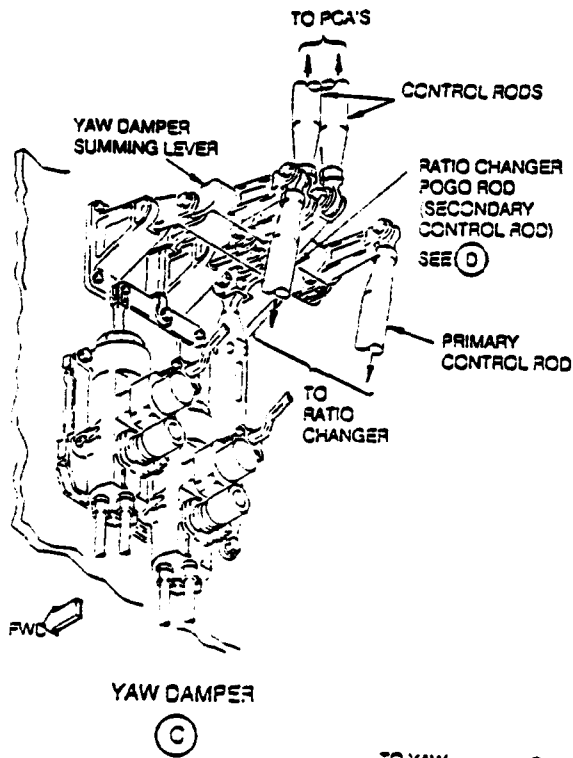

Power Control Actuator (PCA) Adjustment  
Figure 508 (Sheet 2)

19887

## LIST OF REFERENCES

1. Department of the Navy, Office of the Chief of Naval Operations, Memo 03/DU2211, 24 December 1986.
2. Associated Press Wire Service. "Damn the Paperwork. Full Speed Ahead", *The Washington Post*, 5 May 1987.
3. Dorsey, J., "Navy Acts to Erase Paper From Ships", *The LedgerStar*, 6 April 1987.
4. Department of Defense, CALS Core Requirements Coordination Draft, March 1987.
5. Department of Defense, Office of the Secretary of Defense, Military Standard : Automated Interchange of Technical Information, 24 March 1987.
6. Hughes Aircraft Company Support Systems, *Navy Technical Information Presentation System (NTIPS) Final Report Volume 1*, 30 January 1982.
7. Department of the Navy, Office of the Chief of Naval Operations, OPNAV Notice 5440, 4 August 1986.
8. NALCOMIS ADS Development Plan, NAVAIRSYSCOM (APC-5) (PMA-270) as of 19 January 1977, Chief of Naval Operations, 15 October 1976 with change 6 of October 1982.
9. NALCOMIS System Decision Paper, NAVAIRSYSCOM, Mission Element Need Statement (MENS), Enclosure 1 of System Decision Paper, 3 April 1984.
10. NALCOMIS System Decision Paper, NAVAIRSYSCOM, 3 April 1984.
11. Chief of Naval Operations (CNO) CODE OP-51, Functional Description for ADP Support of Naval Flight Record System (NAVFLIRS), May 1984.
12. "Apple, IBM Play New Tunes" *CD-ROM Review*, v. 2 no. 3, August 1987.
13. Byers, T. J., "Built by Association", *PC World*, v. 5, no. 4, April 1987.
14. Dixon, Bradford N., "The Grolier Electronic Encyclopedia", *CD-ROM Review*, v. 1, no. 1, August 1986.

15. Frink, Stephen H., "Optical Memory Cards: A Comparison with Other Current Technologies and Potential Military Applications", Master's Thesis, Naval Postgraduate School, Monterey, California, September 1987.
16. Strukhoff, Roger, "Finding a Common Ground", *CD-ROM Review*, v. 2, no. 1, March/April 1987.
17. Strukhoff, Roger, "The Optical Recording Project", *CD-ROM Review*, v. 2, no. 3, August 1987.
18. Naval Air Development Center Report No. 86118-50, "Military Optical Disk Study", Stang, D. R., Sperry Corporation - Final Report - Contract No. N62269-86-C-0422, August 1986.
19. Jaekel, Carl and Manns, Basil, "'Optical Disk' Encompasses Competing Technology", *Government Computer News*, v. 6, no. 6, 27 March 1987.
20. Green, Timothy J., "Benefits of WORM Make It a Valuable Supplement", *Government Computer News*, v. 6, no. 15, 31 July 1987.
21. Hudson, Richard L., "Eraseable Optical Disk Comes Closer, but Problems Remain", *The Wall Street Journal*, 5 September 1986.
22. McLeod, Jonah, "Optical Storage - It May Be Close to Challenging Magnetics", *Electronics*, 19 May 1986.
23. Lind, D. J., "Optical Laser Technology, Specifically CD-ROM, and Its Application to the Storage and Retrieval of Information", Master's Thesis, Naval Postgraduate School, Monterey, California, June 1987.
24. Lambert, Steve and Ropiequet, Suzanne, *CD-ROM: The New Papyrus*, Microsoft Press, 1968.
25. *Apple 3.5" and 5.25" Disk Drive Owner's Guides*, Apple Computer Inc., 1986.
26. Naval Air Development Center Report No. 87002-50, "Military Optical Disk Study", Fairchild Communications & Electronics Company - Final Report - Contract No. N62269-86-C-0424, December 1986.
27. Chen, Peter Pin-Shan, "The Compact Disc ROM: How It Works", *IEEE Spectrum*, April 1986.
28. McCloskey, Paul, "Scanners", *Federal Computer Week*, v. 1, no. 17, 20 July 1987.
29. Thiel, Thomas J., "Laboratory Studies High-Density Information Options", *Government Computer News*, v. 6, no. 6, 5 June 1987.

30. McCarthy, Vance, "Much at Stake in EIDS Suit", *Federal Computer Week*, v. 1, no. 3, 13 April 1987.
31. Munro, Niel, "Army, Air Force Team up on Optical-Disk Storage", *Government Computer News*, v. 6, no. 17, 28 August 1987.
32. Price, Douglas S., "Government Expected to be Major User of CD-ROM", *Government Computer News*, v. 6, no. 13, 17 July 1987.
33. Armstrong, Anne A., "CD-ROM Takes Off", *Federal Computer Week*, v. 1, no. 2, 13 April 1987.
34. Head, Robert V., "CD-ROM Interfaces May Supersede Bulletin Boards", *Government Computer News*, v. 6, no. 13, 19 July 1987.
35. Meridian Data, INC. Newsletter, *CD Publisher News*, 15 February 1987.
36. Robinson, Phillip, "CD-ROM's Future--The First Users Will Be Business", *San Jose Mercury News*, 19 February 1987.
37. Vizachero, Rick, "Agencies Explore CD Technology", *Government Computer News*, v. 6, no. 4, 27 February 1987.
38. Vizachero, Rick, "CD-ROM Helps Navy Build 'Paperless Ship' Concept", *Government Computer News*, v. 6, no. 15, 31 July 1987.
39. Bass, Brad, "Hopper's Vision Keeps Technology in Perspective", *Government Computer News*, v. 6, no. 8, 19 June 1987.

## BIBLIOGRAPHY

- Ammon, George; Calabria, Joseph; Thomas, Douglas. "A High-Speed, Large Capacity "Jukebox" Optical Disk System", *Computer*, July 1985, pp. 36-44.
- Ambrosio, Johanna, "Optical-Disk Products Grab Limelight at Trade Show", *Government Computer News*, v. 6, no. 12, 19 June 1987, p. 62.
- Armstrong, Anne A. "Navigating With Search Software", *Federal Computer Week*, v. 1, no. 16, 13 July 1987, pp. 26-28.
- Barnes, Robert B., and Sukernick, Frank J., "Files On a Card", *Journal of Information & Image Management*, v. 19, no. 10, October 1986, pp. 34-37.
- Barnes, Robert B., "The Magic Card--Possibilities for Publishing", paper presented at 8th Annual Meeting to the Society for Scholarly Publishing, San Francisco, Ca., May 1986.
- Bender, Eric. "Bright Lights on Financial Data", *PC World*, v. 5, no. 4, April 1987, pp.240-243.
- Betts, Mitch, "Federal Agencies Driving Market For Optical Disk Storage", *Computerworld*, 14 April 1986, p. 13.
- Bonci, Glenn. "Optical Cards: Mass Memory to Go", *Market Monitor*, December 1986, pp. 1-3.
- Brewer, Bryan, "Ready When You Are, CD-I", *PC World*, v. 5, no.4, April 1987, pp. 252-255.
- Byers, T. J., "Built by Association", *PC World*, v. 5, no. 4, April 1987.
- Casatelli, Christine. "Data Center Addresses Storage Problems via CD-ROM", *Federal Computer Week*, v.1 , no. 20, 10 August 1987, p. 12.
- Cohen, Charles L. "Sony, Hitachi Ready Erasable Optical Disks" *Electronics Week*, October 22, 1984, pp.17-18.
- Crown, Jeffrey, Karpovich, John, and others. "GCN Spotlight on Storage Technology". *Government Computer News*, v. 6, no. 6, 27 March 1987, pp. 31-54. Cummings, Steve. "Mastering Corporate Data", *PC World*, v. 5, no. 4, April 1987, pp. 232-235.
- Desmarais, Norman. "Laser Libraries--Publishers Are Providing Information on Optical Disks", *Byte*, v. 11, no. 5, May 1986, pp. 235-246.
- Esparza, Mary S., "Optical Disk Storage: Short On Delivery ?", *Infosystems*, v. 34, no. 3, March 1987, pp. 48-50.
- Freiberger, Paul,, "CD-ROM's New Starring Role", *San Francisco Chronicle*, 8 March 1987, p. D-3.
- Geest, D. C., Cochius, Ir. and Bruno, R., "Optical Media in Perspective", Philips Marketing Publication, New Media Systems Information Center, March 1987.

- Giglio, Louis, "Optical Disks: Users Will Believe It When They See It", *Information Week*, no. 30, September 2, 1985, pp.42-44.
- Giglio, Louis, "Optical Storage Cuts Out Paper" *Information Week*, no. 21, July 1, 1985, pp. 48-49.
- Helgerson, Linda W., "Optical Disc Technology: Optical Discs New Storage Media for Education", *T.H.E. Journal*, v. 14, no. 7, March 1987
- Howe, Charles L., "Optical Storage Arrives" *Datamation*, v. 31, no. 17, 1 September 1985, pp. 38-44.
- Hudson, Richard L., "Eraseable Optical Disk Comes Closer". *The Wall Street Journal*, 5 September 1986, p. 16.
- Kildall, Gary A. and Oren, Tim. "The Compact Disk ROM: Applications Software". *IEEE Spectrum*, v. 23, no. 4, April 1986, pp.49-54.
- Lambert, Steve; Ropiequet, Suzanne, *CD-ROM: The New Papyrus*, Microsoft Press, 1986.
- Laub, Leonard. "The Evolution of Mass Storage". *Byte*, v. 11, no. 5, May 1986, pp. 161-172.
- Luskin, Bernard. "What is CD-I?", *T.H.E. Journal*, v. 17, no. 7, March 1987, p. 52.
- "Mass Storage: Erasable Optical Disks Are on The Horizon" *Electronics*, v. 58, no. 25, 24 June 1985, pp. 67-69.
- McCloskey, Paul. "Scanners", *Federal Computer Week*, v. 1, no. 17, 20 July 1987, pp. 26-28.
- McLeod, Jonah, "Optical Storage: It May Be Close to Challenging Magnetics" *Electronics*, May 19, 1986, pp. 30-33.
- McManus, Reed, "The Reference ROM", *PC World*, v. 5, no. 4, April 1987, pp. 236-239.
- Moore, Steve, "The Mass Storage Squeeze" *Datamation*, v. 30, no. 16, October 1, 1984, pp.69-79.
- Nace, Ted. "State of the Art: Optical Storage - Lighting a Path to the Future". *Macworld*, February 1986, pp. 100-106.
- Noble, Marc, "Optical Storage Tech Squaring Off With Magnetic Media" *Government Computer News*, v. 4, no.23, 6 December 1985, p. 43.
- Optical Discs: An Information Revolution*, IEEE Handout accompanying Satellite Seminar on Optical Technology, 26 February 1987.
- Pin-Shan Chen, Peter, "The Compact Disk ROM: How It Works" *IEEE Spectrum*, v. 23, no. 4, April 1986, pp.44-49.
- Raimondi, Donna. "Optical Disk Storage Dawns" *Computerworld*, 23 December 1985, pp. 1,26.
- Robinson, John, "Optical Systems Erode Mass Storage Barriers". *Computer Design*, v. 25, no. 9, 1 May 1986, pp. 101-106.

- Ropiequet, Suzanne; Einberger, John; Zoellick, Bill, *CD-ROM 2: Optical Publishing* Microsoft Press, 1987.
- Rose, Craig D., "The Move to PC-Based Image Storage", *Electronics*, May 12, 1986, p. 19.
- Rosenberg, Robert, "Juke Box Stores Trillions of Bits of Space Data" *Electronics Week*, 8 October 1984, pp. 17-18.
- Roteilo, Joseph, Jr., "Laser Disks-No Optical Illusion" *Microcomputing*, v. 6, no. 10, October 1984, pp. 68-71.
- Rothchild, Edward S., "Optical Memory: Data Storage by Laser", *Byte*, v. 9, no. 11, October 1984, pp. 215-224.
- Rothchild, Edward S., "An Eye on Optical Disks", *Datamation*, v. 32, no. 5, 1 March 1986, pp. 73-74.
- Rothchild, Edward S., "Optical Storage Emerges as Serious Option for Specialty Jobs", *Computerworld*, v. 20, no. 9, March 3, 1986, p. 18.
- Sehr, Barbara K., "High Noon for CD-ROM", *Datamation*, v. 32, no. 21, 1 November 1986, pp. 79-88.
- Shuford, Richard S., "CD-ROMs and Their Kin", *Byte*, v. 18, no. 12, November 1985, pp. 137-146.
- Strukhoff, Roger, "CD-ROM Review: The Magazine of Compact-Disc Data Storage", CW Communications: Peterborough Inc., 1987.
- Vacca, John R., "Shifting Winds of Storage", *Computerworld*, v. 20, no. 15A, 16 April 1986, pp. 29-33.
- Vizachero, Rick, "Agencies Explore CD Technology", *Government Computer News*, v. 6, no. 4, 27 February 1987.
- Vizachero, Rick, "New Retrieval System Uses Laser Disks", *Government Computer News*, v. 5, no. 20, 10 October 1986.
- Vizachero, Rick, "Optical Storage Gets Agencies' Attention", *Government Computer News*, v. 5, no. 24, 5 December 1986.
- Weldon, David, "Look at Optical Storage", *Computer Decisions*, December 2, 1986, pp. 61-62.

## INITIAL DISTRIBUTION LIST

	No. Copies
1. Defense Technical Information Center Cameron Station Alexandria, VA 22304-6145	2
2. Library, Code 0142 Naval Postgraduate School Monterey, CA 93943-5002	2
3. Chief of Naval Operations Director Information Systems (OP-945) Navy Department Washington, D. C. 20350-2000	1
4. Lcdr. Robert J. Clarey 3345 Xenophon Street San Diego, CA. 92106	4
5. Commander, Naval Air Technical Services Facility Attn: Policy and Plans Division-Mr. Jerry Gruden 700 Robbins Avenue Philadelphia, PA. 19111	2
6. Dr. Norman Lyons, Code 54LB Administrative Sciences Department Naval Postgraduate School Monterey, CA. 93943	2
7. Cdr. Lewis G. Mason Code 52MA Department of Computer Science Naval Postgraduate School Monterey, CA. 93943-5000	2
8. Lcdr. Barry Frew Code 54FW Administrative Sciences Department Naval Postgraduate School Monterey, CA. 93943	2
9. Lcdr. David J. Lind, USN Naval Data Automation Command (Code 30) Washington Navy Yard Washington, D. C., 20374-1662	1
10. Lt. Stephen Frink Naval Air Reserve NAS Norfolk Norfolk, VA. 23511-5797	1

11. Mr. Joe Fuller (Code 182) 1  
David Taylor Naval Ship Research and Development Center  
Bethesda, MD. 20084
12. Naval Air Development Center 1  
Department of the Navy  
Attn: Roman Fedorak (Code 5023)  
Warminster, PA. 18974-5000
13. Diane Squire 1  
Publishers Data Services Corporation  
2511 Garden Road  
Building C  
Monterey, CA. 93940
14. Mr. Don Bissell 1  
Sundstrand Corporation  
Technology Development Division  
275 E. Baker St.  
Costa Mesa, CA. 92626
15. Mr. Athos Fodon or 1  
Mr. Jim Tillinghast  
Palantir Corporation  
2500 Augustine Drive  
Santa Clara, CA. 95054
16. Mrs. Dorothy Clarey 1  
5843 Wye Oak Common Court  
Burke, VA. 22015
17. Mr. Donald Clarey 1  
Deputy Administrator  
Small Business Administration  
1441 L Street N. W.  
Washington, D. C. 20005
18. Patricia Clarey 1  
Special Assistant  
Office of the Secretary  
U.S. Department of the Interior  
18TH & C Streets, N. W.  
Washington, D. C. 20240

END

DATE

FILMED

JAN

1988