



MICROCOPY RESOLUTION TEST CHART
NATIONAL BUREAU OF STANDARDS-1963-A

AD-A186 469

NAVAL POSTGRADUATE SCHOOL

Monterey, California



DTIC
SELECTED
NOV 25 1987
S E D

THESIS

A STUDY OF THE FEASIBILITY OF USING A BURIED
SONAR TRANSDUCER TO ECHO-LOCATE OBJECTS
BURIED IN SEDIMENT

by

Roy Dale Malmberg

September 1987

Advisor:

Steve Baker

Approved for public release; distribution is unlimited

UNCLASSIFIED

SECURITY CLASSIFICATION OF THIS PAGE

REPORT DOCUMENTATION PAGE

1a REPORT SECURITY CLASSIFICATION UNCLASSIFIED		1b RESTRICTIVE MARKINGS	
2a SECURITY CLASSIFICATION AUTHORITY		3 DISTRIBUTION/AVAILABILITY OF REPORT Approved for public release; distribution is unlimited	
2b DECLASSIFICATION/DOWNGRADING SCHEDULE			
4 PERFORMING ORGANIZATION REPORT NUMBER(S)		5 MONITORING ORGANIZATION REPORT NUMBER(S)	
6a NAME OF PERFORMING ORGANIZATION Naval Postgraduate School	6b OFFICE SYMBOL (if applicable) Code 55	7a NAME OF MONITORING ORGANIZATION Naval Postgraduate School	
6c ADDRESS (City, State, and ZIP Code) Monterey, California 93943-5000		7b ADDRESS (City, State, and ZIP Code) Monterey, California 93943-5000	
8a NAME OF FUNDING SPONSORING ORGANIZATION	8b OFFICE SYMBOL (if applicable)	9 PROCUREMENT INSTRUMENT IDENTIFICATION NUMBER	
8c ADDRESS (City, State, and ZIP Code)		10 SOURCE OF FUNDING NUMBERS	
		PROGRAM ELEMENT NO	PROJECT NO
		TASK NO	WORK UNIT ACCESSION NO
11 TITLE (include Security Classification) A STUDY OF THE FEASIBILITY OF USING A BURIED SONAR TRANSDUCER TO ECHO-LOCATE OBJECTS BURIED IN SEDIMENT			
12 PERSONAL AUTHOR(S) Malmberg, Roy D.			
13a TYPE OF REPORT Master's Thesis	13b TIME COVERED FROM TO	14 DATE OF REPORT (Year Month Day) 1987, September	15 PAGE COUNT 46
16 SUPPLEMENTARY NOTATION			
17 COSATI CODES		18 SUBJECT TERMS (Continue on reverse if necessary and identify by block number)	
FIELD	GROUP	SUB-GROUP	
		Echo-Locate; Sonar in Sediment	
19 ABSTRACT (Continue on reverse if necessary and identify by block number) An analysis is conducted to determine the feasibility of using a buried sonar transducer to echo-locate torpedoes imbedded in sediment. The active sonar equation is examined and representative values for each term are developed which are appropriate for the sediment on the acoustic test ranges at the Naval Undersea Weapons Engineering Station, Keyport, Washington. It is found that transmission loss through the sediment limits the useful range of the proposed 10 kHz active sonar system to approximately 10 meters, thus rendering it impractical as a localization tool. Three alternative systems are proposed for further consideration.			
20 DISTRIBUTION AVAILABILITY OF ABSTRACT <input checked="" type="checkbox"/> UNCLASSIFIED UNLIMITED <input type="checkbox"/> SAME AS RPT <input type="checkbox"/> DTIC USERS		21 ABSTRACT SECURITY CLASSIFICATION Unclassified	
22a NAME OF RESPONSIBLE INDIVIDUAL Prof. Steve Baker		22b TELEPHONE (Include Area Code) (408) 646-2732	22c OFFICE SYMBOL Code 61Ba

DD FORM 1473, 84 MAR

83 APR edition may be used until exhausted
All other editions are obsolete

SECURITY CLASSIFICATION OF THIS PAGE

UNCLASSIFIED

Approved for public release; distribution is unlimited

A Study of the Feasibility of Using a Buried
Sonar Transducer to Echo-Locate Objects
Buried in Sediment

by

Roy Dale Malmberg
Lieutenant, United States Navy
B.S., University of Oklahoma, 1980

Submitted in partial fulfillment of the
requirements for the degree of

MASTER OF SCIENCE IN SYSTEMS TECHNOLOGY
(ANTISUBMARINE WARFARE)

from the

NAVAL POSTGRADUATE SCHOOL
September 1987

Author:



Roy Dale Malmberg

Approved by:



Steve Baker, Thesis Advisor



Oscar B. Wilson, Second Reader



R.N. Forrest, Chairman
Antisubmarine Warfare Academic Group

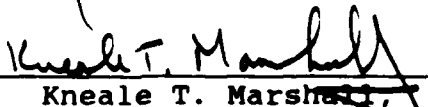

Kneale T. Marshall,
Acting Academic Dean

ABSTRACT

An analysis is conducted to determine the feasibility of using a buried sonar transducer to echo-locate torpedoes imbedded in sediment. The active sonar equation is examined and representative values for each term are developed which are appropriate for the sediment on the acoustic test ranges at the Naval Undersea Weapons Engineering Station, Keyport, Washington. It is found that transmission loss through the sediment limits the useful range of the proposed 10 kHz active sonar system to approximately 10 meters, thus rendering it impractical as a localization tool. Three alternative systems are proposed for further consideration.

Association For	
NTIS GRA&I	<input checked="" type="checkbox"/>
DTIC TAB	<input type="checkbox"/>
Unannounced	<input type="checkbox"/>
Justification	
By	
Distribution/	
Availability Codes	
Dist	Avail and/or Special
A-1	



TABLE OF CONTENTS

I.	INTRODUCTION -----	7
	A. CURRENT RECOVERY METHODS -----	7
	B. SEDIMENT CHARACTERISTICS -----	9
	C. PROPOSED SONAR RANGING SYSTEM -----	11
II.	SYSTEM ANALYSIS -----	12
	A. SOURCE LEVEL -----	13
	B. TRANSMISSION LOSS -----	14
	1. Most Probable Path -----	14
	2. TL in Sediment -----	16
	C. NOISE LEVEL -----	17
	1. Selection of Receiver Bandwidth -----	17
	2. Noise-Limited vs Reverberation- Limited Performance -----	20
	3. Estimated Noise Level in Sediment -----	24
	D. TARGET STRENGTH -----	28
	E. DETECTION THRESHOLD -----	28
	F. OVERALL SYSTEM PERFORMANCE -----	29
III.	CONCLUSIONS AND RECOMMENDATIONS -----	34
	A. DISCUSSION OF RESULTS -----	34
	1. System Parameters -----	34
	2. Operational Considerations -----	36
	B. REDUCING TRANSMISSION LOSS -----	38
	1. Alternative One -----	38
	2. Alternative Two -----	39

3. Alternative Three -----	40
C. RECOMMENDATION -----	41
APPENDIX: NOISE LEVELS -----	42
LIST OF REFERENCES -----	43
INITIAL DISTRIBUTION LIST -----	44

LIST OF FIGURES

I-1.	Sound Speed Profile -----	10
II-1.	Ray Path Length from Torpedo to Transducer -----	14
II-2.	Estimated Transmission Loss vs Frequency for Ranges of 50, 100, and 150 Meters -----	18
II-3.	Pulse Length Considerations -----	19
II-4.	Noise Masking Level, Reverberation Masking Level, and Echo Level vs Range -----	22
II-5.	Time-Gating to Minimize Reverberation -----	24
II-6.	Noise Level in a 1000 Hz Band vs Frequency in Sediment -----	27
II-7.	Echo Level and Noise Masking Level vs Frequency -----	31
II-8.	Maximum Detection Range vs Frequency -----	33
III-1.	Vertical Array -----	39

I. INTRODUCTION

The Naval Undersea Warfare Engineering Station (NUWES), Keyport, Wa., is responsible for all torpedo testing conducted by the U.S. Navy. The recovery of the torpedoes tested on the various instrumented ranges is also the responsibility of NUWES, including those torpedoes that are negatively buoyant at end of run. Some of these torpedoes become buried in the sediment. The task of recovering such a buried torpedo is much more difficult and time-consuming than that for one merely lying on the sediment surface. The purpose of this research is to investigate the feasibility of employing a buried acoustic ranging system to localize the torpedo and thereby to speed the recovery process.

A. CURRENT RECOVERY METHODS

Underwater recovery of buried ordnance on the various NUWES weapons ranges is accomplished with the aid of SORD IV, an unmanned and remotely controlled deep sea submersible. SORD IV is capable of operating at depths up to 2,500 feet and is equipped with a high resolution active/passive sonar for target acquisition. The vehicle is also equipped with a trainable eductor snout and movable vehicle section that allow for relatively rapid removal of silt. The vehicle is lowered to the bottom, and a pump is

employed to jet away the silt from the suspected location of the torpedo.

Localization of the target is aided by a 45 kHz transducer mounted on the torpedo. Unfortunately, the 45 kHz signal is attenuated rapidly by the sediment, and generates a diffuse signal for sensors mounted on the submersible. Digging for the torpedo then becomes a hit or miss proposition that depends on the skill of the sonar operator to perform omnidirectional passive localization. The operation is further complicated by a ducting of the pinger signal back up the hole left by the torpedo as it slows to a stop. This sound shaft can cause the recovery operation to commence at a point many meters away from the actual location of the torpedo. Successive digs through the sound shaft eventually result in a successful recovery, but only at the expense of much time and effort on the part of recovery personnel.

Active prosecution of the target with side scanning sonars has been attempted with less than optimal results. Recovery personnel report that the sea floor bottom is littered with a wide range of objects that give a strong return when insonified. Additionally, the resolution of current systems (with respect to a torpedo sized body), prevents the operator from accurately discriminating between debris on the bottom and the target of interest.

The combination of these physical phenomena work to inhibit the timely and efficient recovery of buried objects. For these reasons, a more accurate localization system has been considered.

B. SEDIMENT CHARACTERISTICS

Samples of the sediment from the NUWES ranges at Dabob Bay and the Nonoose facility have been analyzed by Wilson and Helton to determine their physical properties [Ref. 1:pp. 11-22]. Of particular interest are the measurements of sound speed, sediment grain size, and porosity as they pertain to acoustic properties. The bottom water sound speed was determined by Helton to be 1487 meters/second at a depth of 396 meters [Ref. 2:p. 36]. The geoacoustic model derived by Helton and presented in Figure I-1 predicts the sound speed in the first 30 meters of sediment, and indicates that the sound speed gradient in the sediment is 1.0/sec. This "slow bottom" gradient acts to refract any energy within the sediment back towards the water/sediment interface.

The recorded depths for torpedo imbedment into the sediment show a predictable dependence upon both impact grazing angle and impact velocity [Ref. 2:pp. 55-59]. An estimated maximum imbedment depth of 20 feet is supported by the recorded data and by discussions with recovery personnel. Accordingly, a conservative worst case value of

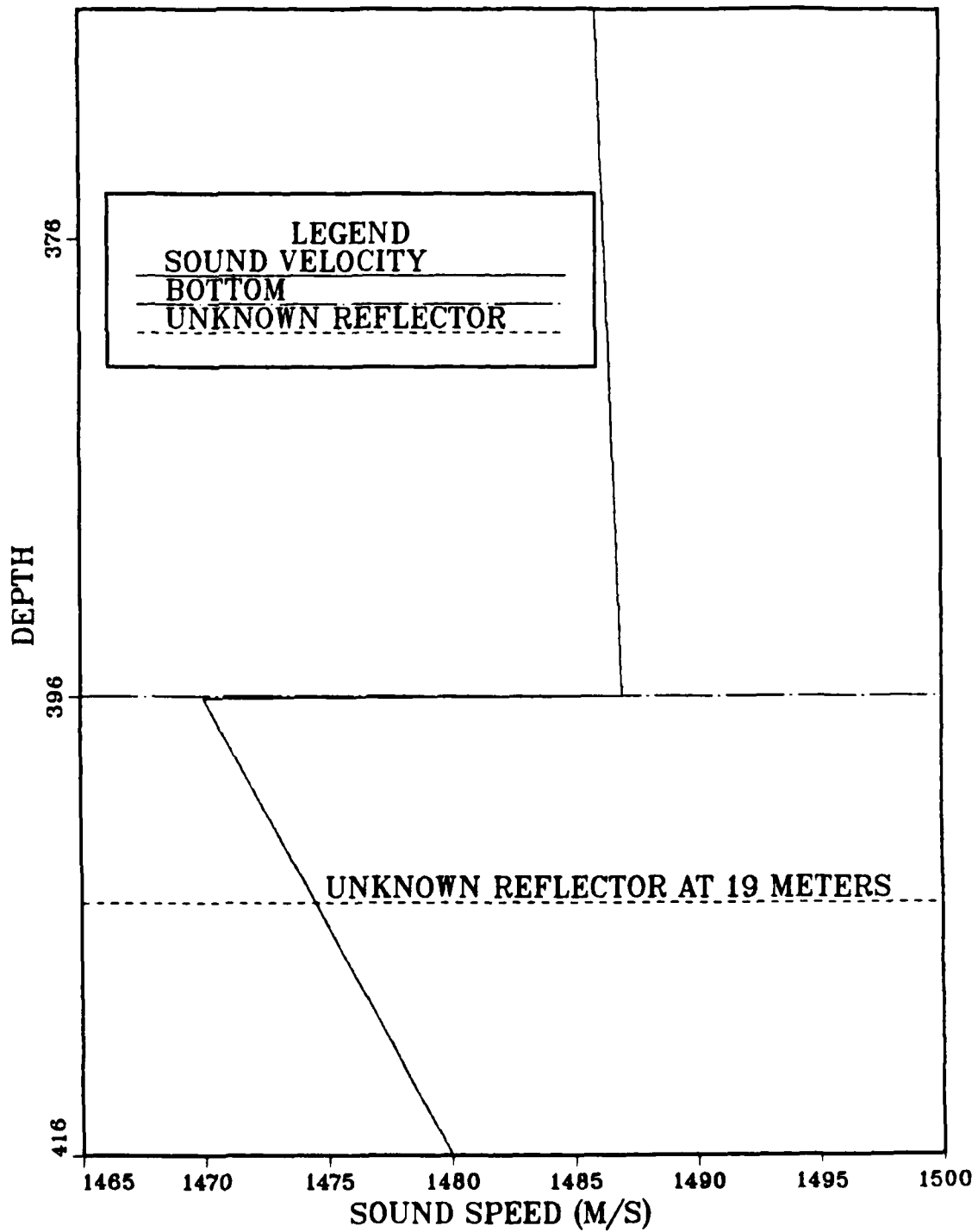

Figure I-1. Sound Speed Profile

20 feet will be assumed for torpedo depth at the commencement of recovery operations.

C. PROPOSED SONAR RANGING SYSTEM

Current NUWES range operations and equipment inventory favor the design of a transducer mounted to the framework of CURV IIA, TROV-N, or SORD IV. A similar system was mounted to CURV II in 1968 through 1972 by the Naval Undersea Center, and was used to measure attenuation characteristics in the sediment off the coast of southern California [Ref. 3:p. 7]. These tests validated the concept of using the weight of the vehicle to drive a probe into a soft silty-clay bottom. A transducer mounted to a platform resting on the bottom could be used to determine a range to the target of interest. Repositioning the vehicle would then yield a triangulation solution for the exact location of the torpedo. Further refinements to the transducer could include directional capability, thus removing the need to reposition the platform. The performance of such a system is analyzed in Chapter II; conclusions and recommendations follow in Chapter III.

II. SYSTEM ANALYSIS

To assess the feasibility of using an echo-ranging system to locate torpedoes buried in sediment, an analysis of the components of the active sonar equation will be performed. The appropriate form of the active sonar equation for a monostatic, noise-limited application is:

$$SL - 2TL + TS \geq NL - DI + DT \quad (1A)$$

$$SL - 2TL + TS \geq RL + DT \quad (1B)$$

where SL is the source level of the projector to be buried in the sediment, 2TL is the two-way transmission loss between the projector and torpedo, TS is the target strength of the buried torpedo, RL is the reverberation level produced by the active signal, NL is the noise level, DI is receiving directivity index, and DT is the detection threshold [Ref. 4:p. 29]. The left side of Equations (1A) and (1B) is termed the echo level, while the right side represents the noise-masking level. Equation (1B) is appropriate where reverberation dominates noise, and Equation (1A) where noise dominates reverberation. When the echo level is equal to or exceeds the noise-masking level, detection is possible.

In the analysis which follows, the performance of the system will be assumed to be noise limited rather than reverberation limited, and so Equation (1A) will be used. Several factors lead to this assumption, and they will be discussed in greater detail in the section dealing with noise level. Additionally, because the system will use a single omnidirectional transducer, the directivity index will be assumed to be zero. The remainder of this chapter is devoted to a discussion of each term in Equation (1A).

A. SOURCE LEVEL

Choosing a realistic source level for a sediment echo-ranging system was based on a cross section of transducers currently in use by the Naval Research Laboratory, Underwater Sound Reference Detachment. In the frequency range 40 Hz to 20 kHz, the J9 Transducer is capable of producing 150 dB [Ref. 9:p. 123]. The J11 Transducer produces better than 155 dB in the 20 Hz to 12 kHz range [Ref. 9:p. 129]. Another example of a projector with specifications suitable for sediment insonification was developed and deployed by the Civil Engineering Laboratory, Naval Construction Battalion Center, Port Hueneme, California in 1977 [Ref. 10:p. 4]. This transducer was part of a system which was designed to accurately measure the shear strength and loading capabilities of deep ocean bottoms. These devices were capable of output source levels in the range of 180 to 190 dB at 12 kHz.

Assuming that the geometry of these transducers can be adapted to a probe that is driven into the sediment, it is reasonable to assume 150 dB as an attainable and realistic source level for an active echo-ranging system.

B. TRANSMISSION LOSS

1. Most Probable Path

To correctly predict the transmission loss associated with an active echo-ranging operation, an estimate of the most probable ray path must be made. Figure II-1 portrays a typical recovery scenario. As discussed earlier, the maximum depth of the torpedo at the commencement of recovery operations will be assumed to be 20 feet. The range that a sound ray leaving the torpedo horizontally will travel before striking the water/sediment interface can be calculated as follows.

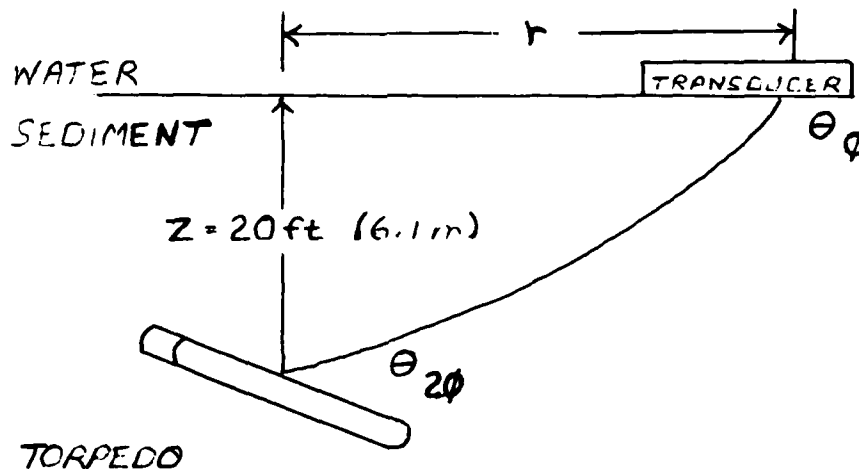

Figure II-1. Ray Path from Torpedo to Transducer

Assuming a constant sound speed gradient of 1/sec in the sediment, the sound velocity in the sediment at a depth of 20 feet (6.1 m) is:

$$c(20) = c(0) + z * g \quad (2)$$

$$c(20) = 1487 \text{ m/s} + 6.1 \text{ m} * 1/\text{sec} \quad (3)$$

$$c(20) = 1493.0 \text{ m/s} \quad (4)$$

Using Snell's Law, the angle that a horizontal sound ray leaving the buried torpedo will make with the sediment/water interface can be found to be:

$$c(0)/\cos(\theta_0) = c(20)/\cos(\theta_{20}) \quad (5)$$

$$\theta_0 = \arccos(1487/1493) \quad (6)$$

$$\theta_0 = 5.138 \text{ degrees} \quad (7)$$

Finally, the horizontal distance can be show to be:

$$r = r[\sin(\theta_0) - \sin(\theta_{20})] \quad (8)$$

$$r = 133.2 \text{ meters} \quad (9)$$

This range is exactly one half the bounce distance for sound trapped within a layer whose depth equals 20 feet, the estimated maximum torpedo imbedment depth. Because this

range is greater than the estimated maximum range of interest, assumed to be approximately 100 meters, the most probable path to and from targets of interest will be direct path. Accordingly, spherical spreading will be assumed to govern the geometric contribution to the transmission loss.

2. TL in Sediment

A signal undergoing spherical spreading will exhibit a transmission loss that is given by:

$$TL = 20 \log r + a * r \quad (10)$$

where r is the range from source to receiver in meters and a is the absorption coefficient in dB/m [Ref. 5:p. 111]. For silty clays similar to those found on the Nanoose and Dabob Bay Ranges, Hamilton has found that the absorption coefficient a is frequency dependent, and can be modeled by the following relationship:

$$a = K * f \quad (11)$$

where K is an empirical constant that depends on grain size within the sediment, and f is the frequency in kilohertz [Ref. 6:pp. 266-284]. Wilson and Helton have determined that a value of 0.1 dB/m/kHz accurately models the value of K for the sediments of interest [Ref. 1:p. 21]. The relationship then becomes:

$$a = 0.1f \quad (12)$$

As an example, the TL associated with a 10 kHz source operating in silty clay over a 133 meter distance becomes:

$$TL = 20 \log r + 0.1 f * r \quad (13)$$

$$TL = 20 \log (133) + 0.1 (10) * (133) \quad (14)$$

$$TL = 42.4 \text{ dB} + 133.0 \text{ dB} \quad (15)$$

$$TL = 175.4 \text{ dB} \quad (16)$$

Figure II-2 shows the one-way transmission loss versus frequency for ranges of 50, 100, and 150 meters.

C. NOISE LEVEL

1. Selection of Receiver Bandwidth

The selection of the bandwidth for a system is directly related to the degree of resolution desired. Locating a torpedo buried in the sediment is complicated by many operational constraints. It is, therefore, of paramount importance that precise information be used when deciding where to begin digging with the recovery vehicle. To ensure that the recovery crew will locate and recover the torpedo during its first excavation, we desire a resolution on the order of one meter. For later convenience, we will assume 0.75 meters as the required resolution of our active echo-ranging system. Figure II-3 shows that to resolve the

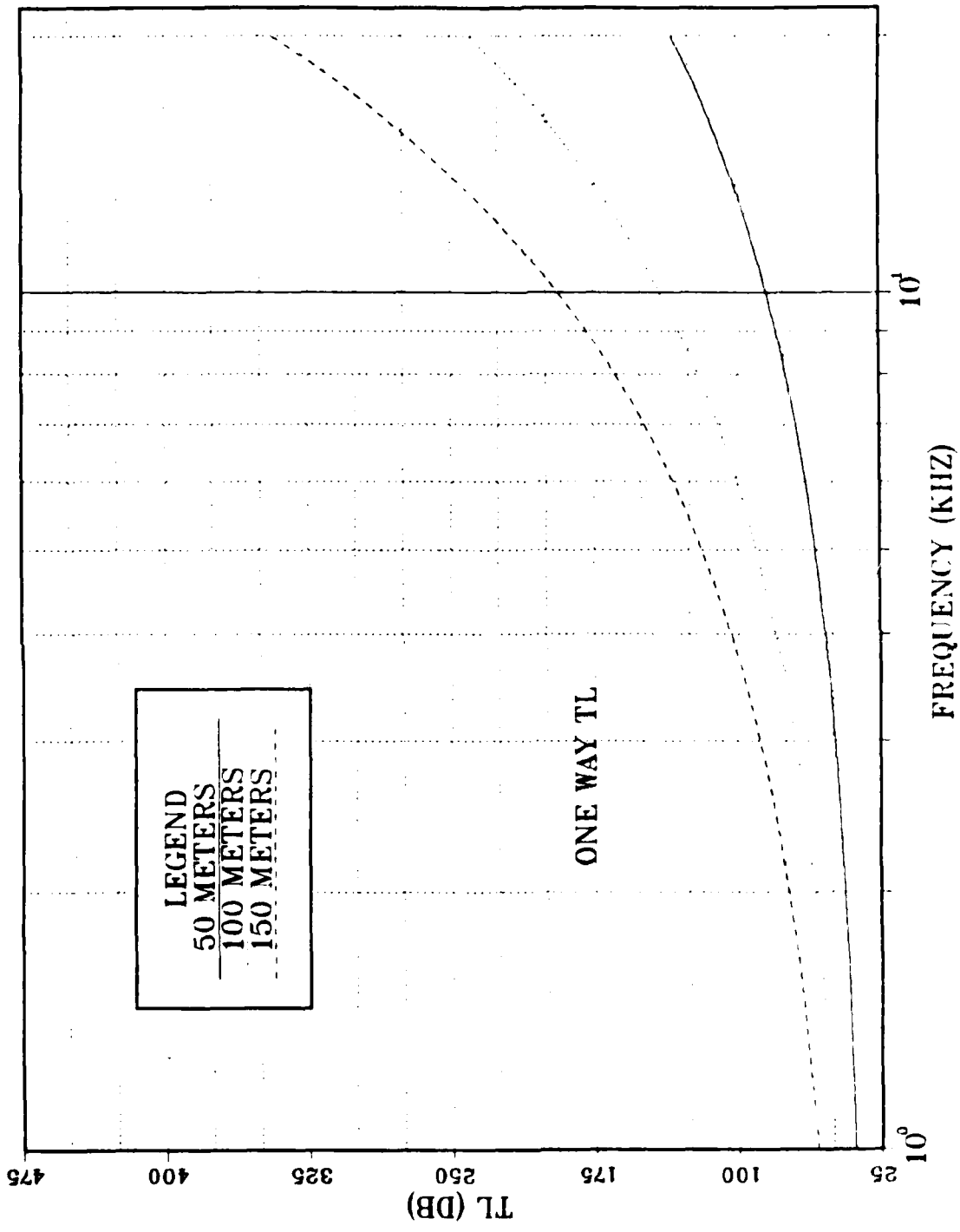

Figure II-2. Estimated Transmission Loss vs Frequency for Ranges of 50, 100, and 150 Meters

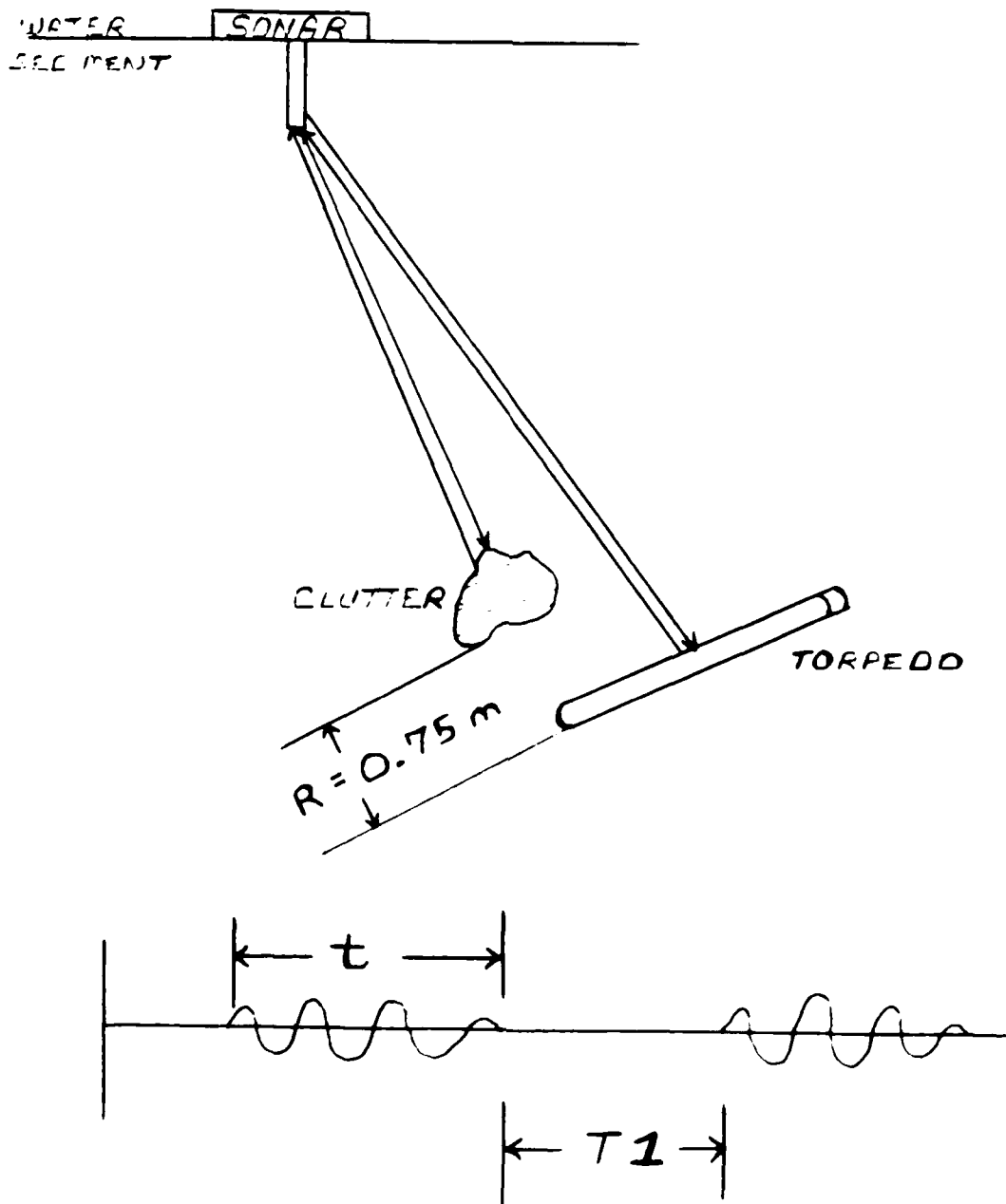

Figure II-3. Pulse Length Considerations

echo returned from two objects 0.75 meters apart, the pulse duration must be shortened to prevent the signals from overlapping. For a range difference of r , the difference in travel times of the sound scattered from the two objects is:

$$T_1 = 2 * r/c \quad (17)$$

$$T_1 = 2 * 0.75 \text{ m}/1500 \text{ m/s} \quad (18)$$

$$T_1 = .001 \text{ sec} \quad (19)$$

where c is the speed of sound, taken to be 1500 meters/second, and T_1 is the time between each individual return [Ref. 8 p. 128]. If the pulse length t is equal to or less than 0.001 second, the scattered returns will just be resolved. The criterion for resolution then becomes:

$$f \geq 1/(t) = (1/0.001) \quad (20)$$

$$f \geq 1000 \text{ Hz} \quad (21)$$

where t is the pulse length in seconds. Therefore, the bandwidth of our receiver must be at least 1000 Hz. However a wider bandwidth will result in a greater noise level, as will be seen in Section II.C.3. Hence, we set the receiver bandwidth equal to 1000 Hz.

2. Noise-Limited vs Reverberation-Limited Performance

If the ambient noise field and the reverberation can be quantified, it may be determined whether the system is

noise-limited or reverberation-limited. The relationship between echo level, reverberation level, and noise level as a function of range is illustrated in Figure II-4 for two hypothetical noise masking levels. If the power output of a transducer is small, the reverberation level will also be small, and the factor limiting the effective range of the system will be background noise. At any given range, and prior to the point when reverberation level (RL) equals the ambient noise level (NL) at that range, increasing the power output of the transducer will increase the signal-to-noise ratio (S/N) available to a detection system. However, once $RL = NL$, increasing the source level of the sonar projector will cause the signal level to increase at the same rate as the reverberation level. Therefore, the best S/N ratio can be achieved when RL just equals NL. Conversely, at any given signal-to-noise ratio, the maximum range for detection will occur when $RL = NL$.

Data on the reverberation level are not available for either the Nanoose or Dabob Bay sediment. For this reason, it is not possible to predict if $RL > NL$ for a source level of 150 dB. However, ambient noise measurements for the area are available, and if we assume that the RL can be kept below the NL with the help of signal processing techniques, then the noise masking levels at any given range can be deduced.

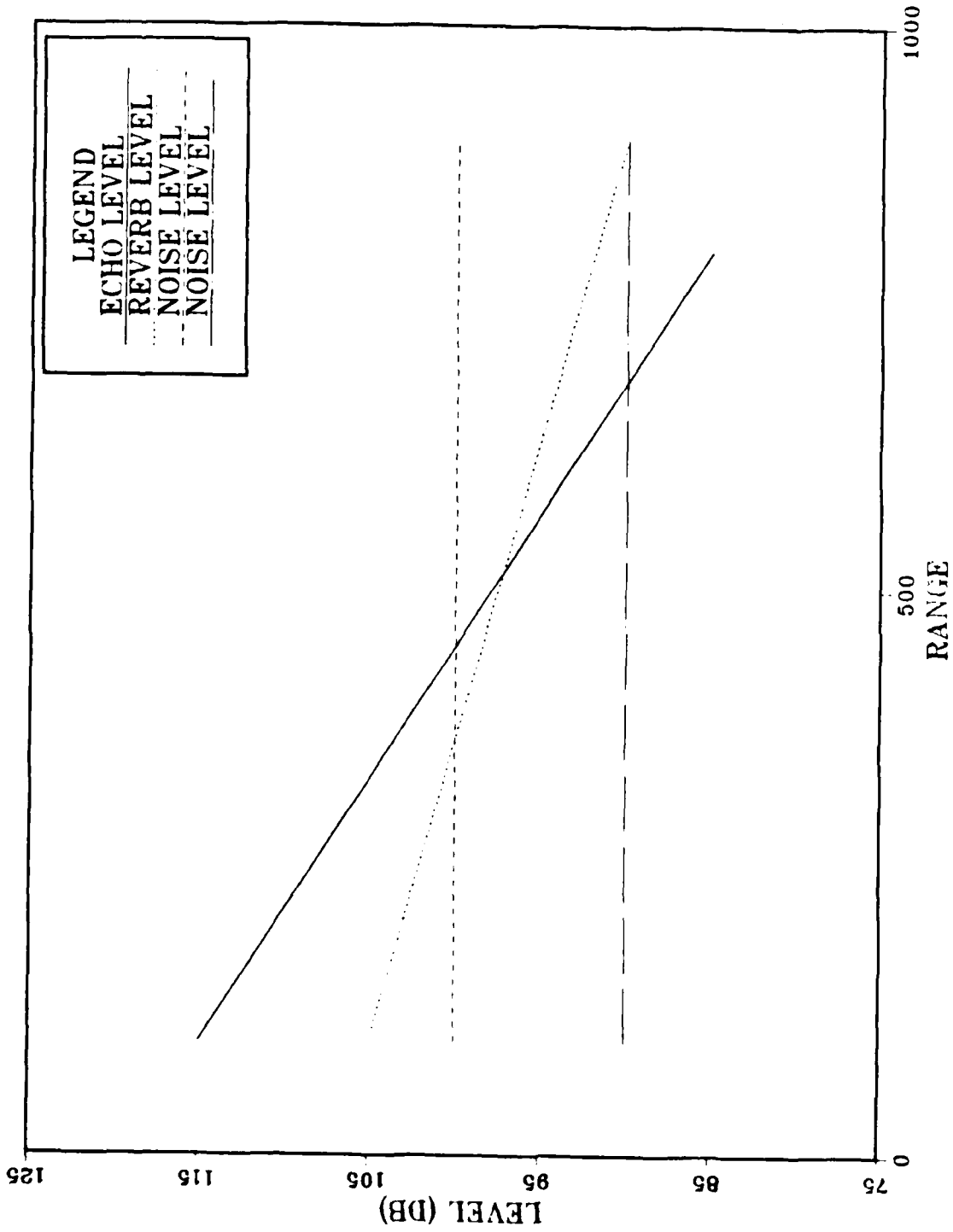

Figure II-4. Noise Masking Level, Reverberation Masking Level, and Echo Level vs Range

Reverberation can be minimized by prudent choice of the active signal broadcast into the medium [Ref. 4:p. 396]. A finite length pulse can be used to reduce the scattering volume; using the previously calculated pulse length of 0.001 second limits the volume of reverberation to a shell with a thickness less than one meter.

According to Helton's geoacoustic model for the Nanoose Range, the strongest source of reverberation is expected to be reflections from a discontinuity of unknown impedance contrast located approximately 19 meters (60 feet) below the water/sediment interface. The dominant returns from this layer, from reflections at normal incidence, will appear as a stationary (in time) echo at a return time of approximately 25 milliseconds on each record. If the transmitted pulse has a duration of only 1 millisecond, however, it is expected that this contamination will only interfere with recognition of targets at a range of approximately 19 ± 1 meters. Figure II-5 illustrates the geometry in which the sonar system is expected to operate.

Reverberation could be reduced by the utilization of a transducer having directionality. A transducer with horizontal directivity will reduce the reverberation from the layer at 19 meters, at the expense of a shadow zone directly below the transducer.

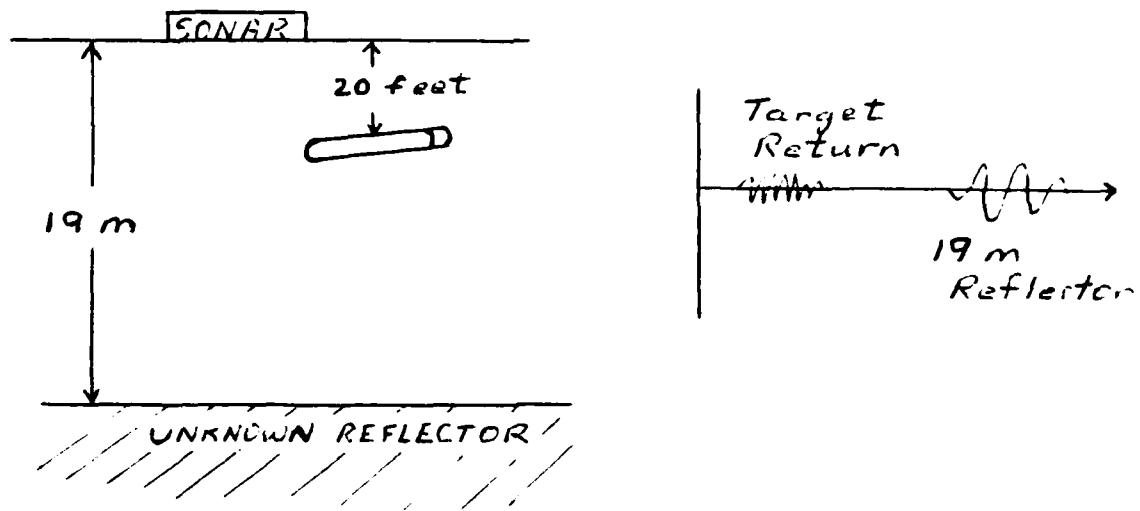

Figure II-5. Time-Gating to Minimize Reverberation

3. Estimated Noise Level in Sediment

Based on a NUWES report published in 1981 [Ref. 7: App. A], ambient noise levels in the sediment have been calculated. Ambient levels were recorded on the Nanoose Range under four different meteorological conditions and two mechanical equipment noise conditions. In order to predict a representative value for the ambient noise level in the sediment, a total of seven different deep water noise-level curves from the report were averaged together. The data chosen represent the deepest data available, and were collected at depths ranging from 600 to 830 feet, in sea states ranging from 0 to 2. The data are tabulated in

Appendix A. The attenuation of the ambient noise as it travels from the point of measurement to the bottom is assumed to be negligible. This is a reasonable assumption since the absorption coefficient for sound in seawater is less than 0.5 dB per 1000 yards at 10 kHz and below [Ref. 4:p. 109]. Neglecting absorption in the estimates of ambient noise at the water-sediment interface introduces an error on the order of one percent.

Noise level is defined as:

$$NL = NSL + 10 \cdot \log (\text{Bandwidth}) \quad (22)$$

where the bandwidth is chosen with respect to the bandpass filter connected to the signal processing system. The NUWES data were recorded with reference to a 23 percent band (1/3 octave). Data presented in this fractional bandwidth format must first be corrected for the bandwidth of the proposed system.

The data referenced to a 23 percent fractional bandwidth can be corrected to a 1000 Hz bandwidth in the following manner:

$$NL = NL_{1/3} - 10 \cdot \log (.23f) + 10 \cdot \log (1000) \quad (23)$$

where $NL_{1/3}$ is the noise level in a 1/3 octave band, and f is the band center frequency in Hz.

Figure II-6 shows various curves of the estimated noise level in a 1000 Hz bandwidth as a function of frequency. The solid line is the average of all seven data sets. It can be seen that the noise level at the water/sediment interface is approximately 75 dB at 10 kHz. The upper and lower dotted curves are the highest and lowest levels out of the seven data sets, and are intended to indicate the range of variability in the observed noise level. The dashed curve is the estimated noise level at a depth of 20 feet into the sediment. This curve was obtained by correcting the average noise level data (the solid curve) for the attenuation of the noise with depth into the sediment using the following formula:

$$NL(d) = NL(0) - 0.1*f*d \quad (24)$$

where:

- NL(d) = estimated noise level at depth d into sediment
- NL(0) = estimated noise level at sediment surface
- f = frequency in kHz
- d = depth in meters.

In making the correction for the attenuation, it was assumed that the noise propagates straight down into the sediment.

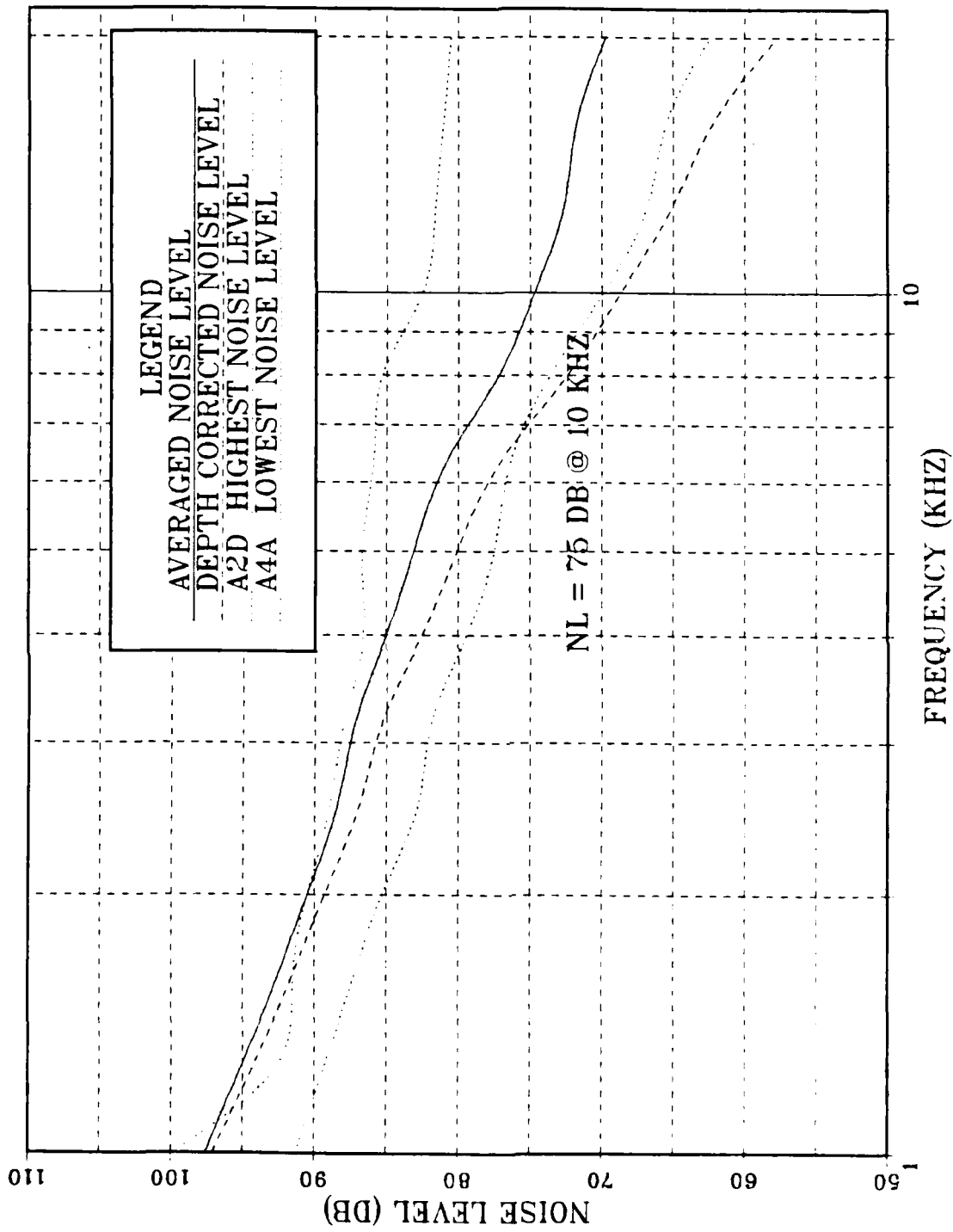

Figure II-6. Noise Level in a 1000 Hz Band vs Frequency in Sediment

D. TARGET STRENGTH

Theoretical formulas that approximate the target strength for various geometries are tabulated by Urick [Ref. 4:pp. 303-305]. The target strength (TS) of any smooth convex object whose dimensions and radii of curvature are large compared with the wavelength is given by:

$$TS = 10 \log(S/16\pi) \quad (25)$$

where S is the surface area. For a 10 kHz signal the associated wavelength is 15 centimeters. The radius of a torpedo is somewhat larger than this, and so the requirement that the wavelength be less than the dimensions and radii of curvature of the object being insonified is essentially satisfied. For a cylinder of radius r equal to 0.5 meters and a length L = 3 meters, Equation (25) becomes:

$$TS = 10 \log(2\pi rL/16\pi) \quad (26)$$

$$TS = -7.2 \text{ dB} \quad (27)$$

Accordingly, the target strength for a torpedo buried in the sediment will be assumed to be -7 dB.

E. DETECTION THRESHOLD

The detection threshold for this system will be calculated assuming that correlation detection is used as a

method of signal processing. Quoting from Coppens, Sanders and Dahl [Ref. 11:p. 115]:

An alternative mode of signal processing is possible in the case of active SONAR. Since the amplitude and frequency properties of the tone burst generated by the source are known, it is possible to search for a signal of these same properties in the received echo. If the detailed shape of the received echo matches that of the sent pulse, then it can be shown that the detection threshold is given by

$$DT = 10 \log(d/2wt) \quad (28)$$

There are many modifications of this basic idea, but all rely on the technique of multiplying the received signal by a time-delayed model of the sent pulse and integrating the resultant product over the pulse duration.

The calculation for detection threshold then becomes:

$$DT = 10 \log(d/2wt) \quad (29)$$

$$DT = 10 \log (15/2*1000*0.001) \quad (30)$$

$$DT = 8.75 \text{ dB} \quad (31)$$

where d is the detection index, w is the bandwidth of the receiver in hertz, and t is the pulse duration in seconds. The value of d is assumed to be 15, and corresponds to a probability of false alarm $P(FA)$ of 0.0001 for a specified probability of detection $P(D)$ of 0.5 [Ref. 11:p. 113]. The DT for the proposed system will be assumed to be 9 dB.

F. OVERALL SYSTEM PERFORMANCE

From the assumptions and calculations of previous sections, an estimate of the performance characteristics

for the proposed echo-ranging system can now be made. For an active system operating at 10 kHz, in silty-clay sediment, over a 1000 Hz bandwidth, in a background assumed to be noise-limited, and at a distance of 133 meters, the evaluation of the sonar equation becomes:

$$SL - 2TL + TS \geq NL + DT \quad (32)$$

$$150 \text{ dB} - 350 \text{ dB} - 7 \text{ dB} \geq 73 \text{ dB} + 9 \text{ dB} \quad (33)$$

$$-207 \text{ dB} \geq 82 \text{ dB} \quad (34)$$

for the specified conditions. Equation (34) must be a true statement for detection to be possible. In this instance, the echo level is not greater than the noise masking level, and detection is not possible.

Figure II-7 is a plot of echo level and noise-masking level versus frequency for ranges of 10, 50, 100, and 150 meters. This graphically shows that detection is not possible at the three larger selected ranges. Further consideration of Equation (32) shows that the maximum possible transmission loss that just allows detection to take place is 59 dB.

$$SL + TS - NL - DT \geq 2TL \quad (35)$$

$$150 \text{ dB} - 7 \text{ dB} - 75 \text{ dB} - 9 \text{ dB} \geq 2TL \quad (36)$$

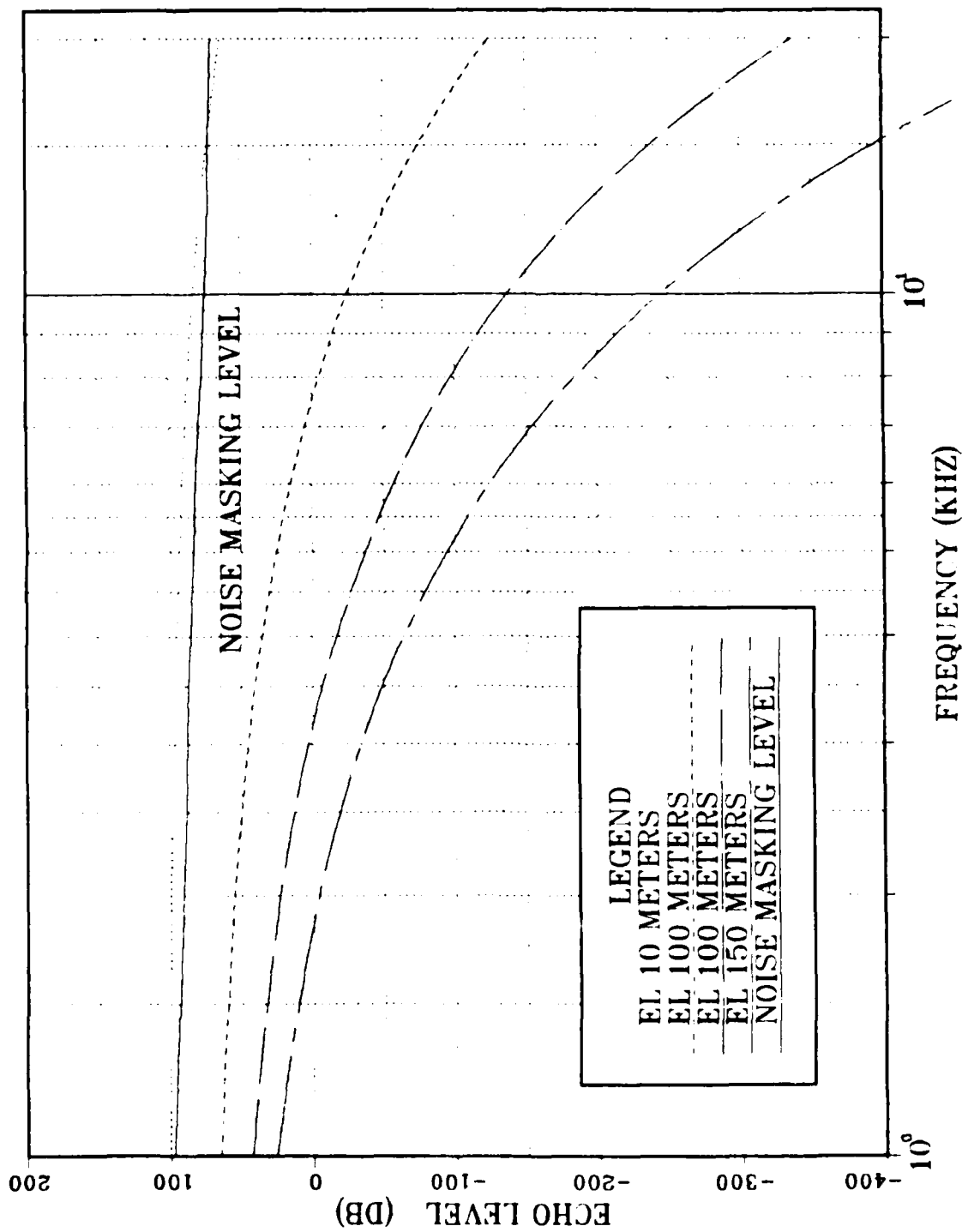

Figure II-7. Echo Level and Noise Masking Level vs Frequency

$$59 \text{ dB} \geq 2\text{TL}$$

(37)

This says that the maximum one-way transmission loss that a 10 kHz signal can undergo is 29.5 dB. Referring to Equation (13), a value of just over 10 meters is predicted for the maximum range of an active echo-ranging system utilizing the sediment as a transmission medium. Figure II-8 illustrates the relationship between maximum detection range and frequency.

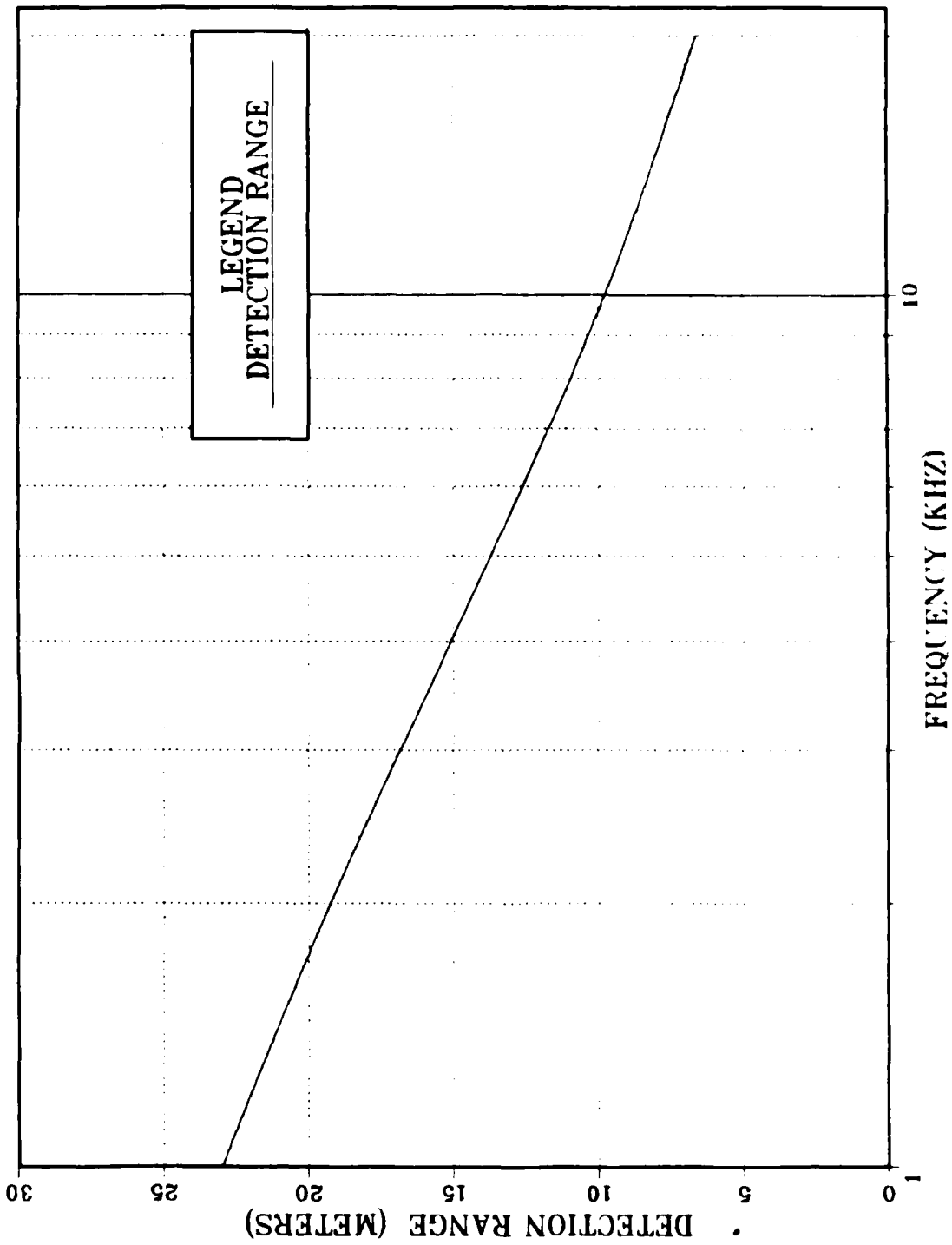

Figure II-8. Maximum Detection Range vs Frequency

III. CONCLUSIONS AND RECOMMENDATIONS

A. DISCUSSION OF RESULTS

1. System Parameters

From Section II.F, the predicted maximum detection range for a practical echo-ranging system with a spatial resolution of approximately 1 meter and which operates in the sediment is on the order of 10 meters. It may be possible to increase this range by a careful review and modification of the performance specifications and assumptions that went into the design of the proposed system. Receiver bandwidth and operating frequency are two possible candidates for consideration.

From Equation (22), it is clear that the noise level for the proposed system could be reduced by using a narrower bandwidth than the chosen 1000 Hz. Choosing a bandwidth of 100 Hz instead, for example, would result in a spatial resolution of 7.5 meters. This might be acceptable for an initial search given that the search area of interest is approximately 100 x 100 meters, and that the effective diameter of the digging submersible is approximately 10 meters. Switching to the wider bandwidth, for a resolution of 0.75 meters, could be done for a final search over a smaller area. Unfortunately, decreasing the receiver bandwidth to 100 Hz will decrease the noise level by only 10

dB. Decreasing the NL from 75 to 65 dB gives only a limited increase in detection range. Referring to Equation (13), a change in TL from 75 dB to 65 dB results in an associated range gain of only 2.5 meters. Therefore, adjusting the receiver bandwidth has a limited effect on the maximum range of detection of the proposed system compared to the desired range of 100 meters, and severely degrades the range resolution.

The discussion in Section II.F shows that the single most important factor influencing the operation of an echo-ranging system is transmission loss. Additionally, the transmission loss is the only term in the echo level equation that is frequency dependent. Reducing the operating frequency from 10 kHz to 5 kHz in an effort to reduce the transmission loss would decrease the one-way TL for a range of 133 meters from 175 dB to 108 dB. The resulting gain in detection range would be only from 10 to 14 meters; a small increase compared to the desired search range.

Additionally, the wavelength associated with a 5 kHz signal is 30 centimeters. A 30 centimeter wavelength would violate the requirement in the calculation of Target Strength (Section II.D) that the wavelength be less than the dimensions and radii of curvature of the torpedo. Both the Mk-48 and Mk-50 ALWT have a radius equal to 16.2 centimeters. A sound wave with a wavelength of 16.2

centimeters has a frequency of 9.3 kHz. Using frequencies lower than this would undoubtedly result in a lower Target Strength than the estimated -7 dB. Even if the theoretical considerations allowed for the operating frequency to be lowered, the nominal increase in maximum detection range of 4 meters would be of only marginal benefit in an effort to increase the effectiveness of the proposed echo-ranging system.

2. Operational Considerations

An area for possible improvement of the effective range of an echo-ranging system is to consider positioning the transducer below the water/sediment interface instead of on top of it. Recalling Equation (24), the ambient noise level is attenuated at the rate of approximately 1 dB per meter at 10 kHz. There would be a 6 dB decrease in the ambient noise level at the assumed maximum torpedo imbedment depth of 20 feet. The gain in echo excess realized by placing the transducer 20 feet into the sediment is still, however, relatively minor when compared to the gain needed to overcome the enormous transmission loss. Additionally, any difference in ray path lengths that might result from driving the transducer deeper into the sediment would be less than one meter for ranges greater than approximately 18 meters. Therefore, the TL would be essentially the same regardless of the depth of the transducer.

Imbedding a transducer into the sediment is not, however, without merit. As a practical matter, placing the transducer in the sediment would have the benefit of reducing the returns from debris resting on the bottom. Assuming that the lobes of the transducer could be designed to project downward, the debris on the top of the sediment would not be insonified. A torpedo imbedded 20 feet into the sediment would then be insonified, while a scatterer directly above it would remain undetected, thus giving the operator the possible advantage of discriminating between them.

A downward looking array would also produce the added benefit of an array gain to a proposed echo-ranging system. Wind and sea surface action is the primary source of the ambient noise, and because it is generated at the surface of the water column and travels downward, the background noise in the sediment is not considered to be isotropic. Therefore, the receive characteristics of a transducer could be designed to discriminate against energy arriving from above the water/sediment interface. This would increase the signal-to-noise ratio at the detector, thereby increasing echo excess. If all the noise arriving from above could be removed by beamforming, the resulting gain in echo excess would be 73 dB, with a corresponding gain in detection range of 26 meters.

B. REDUCING TRANSMISSION LOSS

Transmission loss through the sediment is the dominant factor limiting the performance of an echo-ranging system. However, even when combined, all of the methods for increasing echo excess described in the previous section still would not equal the one-way transmission loss over a range of 133 meters. Reducing the transmission loss is, therefore, the most effective way to increase the range of the proposed system. Three possible methods to solve this problem will be outlined in the remaining portion of this thesis.

1. Alternative One

Reducing path length through the sediment will decrease the attenuation that the signal undergoes. From the previous discussion on Noise Levels, we saw that the attenuation of a signal through the seawater is minimal when compared to the attenuation through the sediment. A way to take advantage of this is to use the water as a transmission medium as long as possible before transitioning into the sediment. A steerable vertical array positioned above the water/sediment interface could be used in this manner to electronically sweep out a footprint in the sediment that would have a radius much greater than the maximum range of 10 meters calculated in Section II.F. Once again though, the problem of discriminating between returns from clutter on the bottom and returns from imbedded torpedoes would

hamper the efforts to localize the object of interest. However, a vertical array mounted on a submersible could subsequently be driven into the sediment after initial contact, then steered to look horizontally, thereby minimizing returns from false targets lying on the top of the sediment. Figure III-1 illustrates how a vertical array might be employed to localize a buried torpedo.

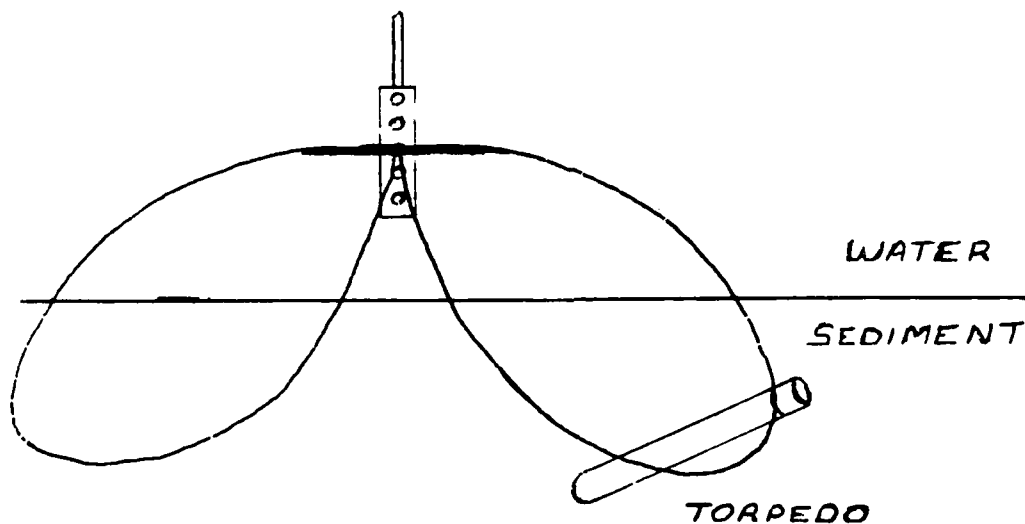

Figure III-1. Vertical Array

2. Alternative Two

Another way to minimize the effects of transmission loss is to concentrate on improving the current passive recovery system vice using an active system for the localization process. Changing the operating frequency of the exercise head transducer from 45 kHz to 10 kHz would

dramatically reduce the transmission loss, thereby increasing the signal-to-noise ratio at the detector. Referring to Equation (10), the one-way transmission loss over a 133 meter distance becomes 140 dB for a 10 kHz signal vice 490 dB for a 45 kHz signal.

3. Alternative Three

Yet another method to improve the performance of the system would be to incorporate a transponder in the torpedo that would respond to a coded signal. This would have the two-fold benefit of keeping a one-way path length for transmission loss purposes, and would also remove the Target Strength contribution from the sonar equation. Equation (1A) would then become:

$$SL - TL \geq NL + DT \quad (38)$$

The source level for this transponder will be assumed to be 150 dB. The use of a transponder also allows a narrower bandwidth to be used. The noise level at 10 kHz corrected for a 100 Hz bandwidth would be 63 dB. Equation (38) becomes:

$$SL - NL - DT \geq TL \quad (39)$$

$$150 \text{ dB} - 63 \text{ dB} - 9 \text{ dB} \geq TL \quad (40)$$

$$78 \text{ dB} \geq TL \quad (41)$$

This results in a detection range of approximately 45 meters, and would represent a marked improvement over the 10 meter range predicted for the active system.

C. RECOMMENDATION

High transmission losses and short ranges characterize an active echo-ranging system operating in sediment. For this reason it is recommended that the frequency of the localization pinger be modified from 45 to 10 kHz to provide an immediate improvement in the signal-to-noise ratio at the detector. The next step in this improvement process could be the incorporation of a transducer system to take advantage of the benefits derived from a one-way path length and narrower receiver bandwidth. Additionally, further study should be devoted to the design of a vertical line array that initially uses seawater as the transmission medium.

APPENDIX

NOISE LEVELS

NOISE LEVELS AVERAGED AND CORRECTED FOR BANDWIDTH AND DEPTH

FREQUENCY	A2A	A2B	A2C	A2D	A4A	A4C	A4D	WEIGHTED AVERAGES	BANDWIDTH CORRECTED	DEPTH CORRECTED
1.00	97.60	88.10	92.20	93.50	84.30	89.00	91.60	91.26	97.66	97.06
1.25	96.20	87.00	90.50	92.80	84.00	87.20	90.50	89.78	95.18	94.43
1.60	94.50	84.70	89.20	91.50	83.00	85.50	89.50	88.29	92.59	91.63
2.00	92.50	84.10	88.20	90.50	81.30	84.50	88.60	87.09	90.49	89.29
2.50	91.60	82.90	87.20	89.00	80.50	83.20	88.20	86.13	88.53	87.05
3.20	91.50	82.50	87.00	87.90	80.50	82.50	87.90	85.80	87.10	85.18
4.00	90.80	81.00	85.60	86.60	79.00	81.20	86.20	84.52	84.92	82.52
5.00	89.50	79.50	83.20	85.70	78.10	80.00	86.00	83.73	85.15	80.15
6.40	88.00	76.00	84.00	85.90	77.90	78.20	84.80	82.34	80.74	76.30
8.00	85.60	73.20	83.00	85.30	76.20	76.00	78.10	79.84	77.24	72.44
10.00	83.80	71.50	80.70	82.50	73.50	73.50	80.50	78.29	74.69	68.69
12.50	80.50	71.00	80.20	81.60	71.50	72.50	80.20	77.28	72.68	65.18
16.00	80.50	71.70	79.80	81.00	71.20	72.50	80.30	77.34	71.74	62.14
20.00	77.50	73.00	79.70	80.50	69.00	71.50	79.20	76.34	69.74	57.74

INDIVIDUAL NOISE LEVELS CORRECTED FOR BANDWIDTH

FREQUENCY	A2A	A2B	A2C	A2D	A4A	A4C	A4D
1.00	104.00	94.50	98.50	99.30	91.30	95.40	98.00
1.25	101.60	92.40	95.90	92.80	89.40	92.60	95.90
1.60	98.90	89.00	93.50	91.50	87.50	89.60	93.90
2.00	95.90	87.50	91.60	90.50	85.50	87.90	92.00
2.50	94.00	85.20	89.60	89.00	82.30	85.60	90.60
3.20	92.80	83.80	88.30	87.90	81.50	83.80	89.20
4.00	91.20	81.40	86.00	86.60	79.40	81.60	86.60
5.00	88.90	79.10	84.60	86.70	77.50	79.40	85.10
6.40	86.40	74.10	82.40	85.90	76.30	78.60	83.20
8.00	83.00	70.60	80.40	85.30	73.60	75.50	80.50
10.00	80.20	67.90	77.10	82.50	70.90	72.90	76.70
12.50	75.90	66.40	75.60	81.60	68.40	70.90	75.60
16.00	74.20	66.10	74.20	81.00	65.40	68.00	75.30
20.00	70.90	66.40	73.10	80.50	62.40	64.90	72.60

LIST OF REFERENCES

1. Naval Postgraduate School, NPS-61-79-005, Acoustic Properties of Sediments at Weapons Test Ranges of the Naval Undersea Warfare Engineering Station, Keyport, Washington, O.B. Wilson and R.H. Helton, June 1979.
2. Helton, R.H., Nanoose Range Bottom Sediment Characteristics, Naval Undersea Warfare Engineering Station, Keyport, Washington, December 1984.
3. Igarashi, Y., In Situ High-Frequency Acoustic Propagation Measurements in Marine Sediments in the Santa Barbara Shelf, California, Naval Undersea Center, San Diego, California, January 1973.
4. Urick, R.J., Principles of Underwater Sound, 3rd Ed., McGraw-Hill, 1983.
5. Kinsler, L.E., Frey, A.R., Coppers, A.B., and Sanders, J.V., Fundamentals of Acoustics, 3rd Ed., John Wiley & Sons, 1982.
6. Hamilton, E.L., Prediction of In-Situ Acoustic and Elastic Properties of Marine Sediments, Geophysics 36, pp. 266-284, 1971.
7. Noise & Acoustics Analysis Division, Code 701, Research and Engineering Department, Naval Undersea Warfare Engineering Station, Keyport, Washington, NAAD TN 12-81, Nanoose Ambient Noise Data Summary, Stageberg, D., April 1981.
8. Clay, C.S., and Medwin, H., Acoustical Oceanography, John Wiley & Sons, 1977.
9. Naval Research Laboratory, Underwater Sound Reference Detachment, Transducer Branch, Underwater Electroacoustic Standard Transducers, May 1982.
10. Civil Engineering Laboratory, Naval Construction Battalion Center, Port Hueneme, Ca., An Expendable Doppler Penetrometer, July 1977.
11. Coppers, A., Sanders, J., Dahl, H., The Sonar Equations, Naval Postgraduate School, Monterey, California, 1981.

INITIAL DISTRIBUTION LIST

	No. Copies
1. Defense Technical Information Center Cameron Station Alexandria, Virginia 22304-6145	2
2. Library, Code 0142 Naval Postgraduate School Monterey, California 93943-5002	2
3. Professor R. Neagle Forrest, Code 55Fo Naval Postgraduate School Monterey, California 93943-5004	1
4. Prof. O.B. Wilson, Code 61Wl Naval Postgraduate School Monterey, California 93943-5004	1
5. Prof. S.R. Baker, Code 61Ba Naval Postgraduate School Monterey, California 93943-5004	5
6. Commander (Code 70) Attn: Robert Marimon Naval Undersea Warfare Engineering Station Keyport, Washington, 98345	2
7. Commanding Officer Attn: Lt R.D. Malmberg VS-41 NAS North Island San Diego, California 92135-5152	4
8. Commander (Code 50) Attn: R.L. Mash Naval Undersea Warfare Engineering Station Keyport, Washington 98345	1
9. Commander (Code 80) Attn: Cdr R. Hillier Naval Undersea Warfare Engineering Station Keyport, Washington 98345	1
10. Commander (Code 7021) Attn: R.H. Evans Naval Undersea Warfare Engineering Station Keyport, Washington 98345	1

11. Commander (Code 7021) 1
Attn: R.A. Helton
Naval Undersea Warfare Engineering Station
Keyport, Washington 98345

12. Commander (Code 0115) 1
Attn: General Administration
Naval Undersea Warfare Engineering Station
Keyport, Washington 98345

END
DATE
FILMED
JAN
1988