

AD

AD-A187 177

TECHNICAL REPORT BRL-TR-2838

FORMATION OF HIGH AMPLITUDE  
PRESSURE WAVES IN A 5-In./54  
LOVA CHARGE

LANG-MANN CHANG

SEPTEMBER 1987

DTIC  
ELECTE  
DEC 16 1987  
S D  
Co E

APPROVED FOR PUBLIC RELEASE. DISTRIBUTION UNLIMITED

US ARMY BALLISTIC RESEARCH LABORATORY  
ABERDEEN PROVING GROUND, MARYLAND

87 12 9 140

## DESTRUCTION NOTICE

Destroy this report when it is no longer needed. DO NOT return it to the originator.

Additional copies of this report may be obtained from the National Technical Information Service, U.S. Department of Commerce, Springfield, VA 22161.

The findings of this report are not to be construed as an official Department of the Army position, unless so designated by other authorized documents.

The use of trade names or manufacturers' names in this report does not constitute indorsement of any commercial product.

AD-A187177

PAGE		Form Approved OMB No 0704-0188 Exp Date Jun 30, 1986	
1b RESTRICTIVE MARKINGS			
2 DISTRIBUTION / AVAILABILITY OF REPORT			
3 MONITORING ORGANIZATION REPORT NUMBER(S)			
4a NAME OF MONITORING ORGANIZATION		4b ADDRESS (City, State, and ZIP Code)	
5a FUNDING / SPONSORING AGENCY		5b SOURCE OF FUNDING NUMBERS	
6a FUNDING / SPONSORING AGENCY		6b ADDRESS (City, State, and ZIP Code)	
7a FUNDING / SPONSORING AGENCY		7b ADDRESS (City, State, and ZIP Code)	
8a FUNDING / SPONSORING AGENCY		8b ADDRESS (City, State, and ZIP Code)	
9 PROCUREMENT INSTRUMENT IDENTIFICATION NUMBER		10 SOURCE OF FUNDING NUMBERS	
PROGRAM ELEMENT NO.		PROJECT NO.	TASK NO.
SEATAFK		62Y00118163	
11 SOURCE OF FUNDING NUMBERS			
PROGRAM ELEMENT NO.			
PROJECT NO.			
TASK NO.			
WORK UNIT ACCESSION NO.			
SEATAFK 62Y00118163			
12 PERSONAL AUTHOR(S)			
Lang-Mann Chang			
13a TYPE OF REPORT		13b TIME COVERED	
Technical Report		FROM 1/86 TO 9/86	
14 DATE OF REPORT (Year, Month, Day)		15. PAGE COUNT	
		30	
16 SUPPLEMENTARY NOTATION			
Presented at 23rd JANNAF Combustion Meeting			
17 COSATI CODES		18 SUBJECT TERMS (Continue on reverse if necessary and identify by block number)	
FIELD	GROUP	SUB-GROUP	
			5-In./54 Gun, LOVA Charge, Simulator Diagnostics, Ignition Studies, Pressure Waves, Flamespreading, Grain Fracture
19 ABSTRACT (Continue on reverse if necessary and identify by block number)			
<p>The ignition process occurring in the 5-inch, 54-caliber (5-in./54) LOVA (Lot 2163BL) charge was investigated via simulator diagnostics. The ignition system of the charge was the Mk 45 Mod 1 primer with Class 2 black powder as igniter material. This investigation was carried out to determine the cause of the high-amplitude pressure waves exhibited on the pressure-time curves recorded in gun firing tests. The results obtained also provided guidance for the development of an improved ignition system for the charge. The diagnostics proceeded with ignition of the primer in empty chambers, then in inert propellant packed chambers, and finally with live LOVA charges. The results from all of the experiments clearly indicate that localized venting of igniter gases from the primer was responsible for the occurrence of the pressure waves. The venting was so strong that it caused severe grain fracture not only in the region covered by the venting but also at the breech and the forward ends of the propellant bed. The grain fracture gave a sudden increase in burning surface area. This further enhanced the pressure waves generated by</p>			
20 DISTRIBUTION / AVAILABILITY OF ABSTRACT		21 ABSTRACT SECURITY CLASSIFICATION	
<input checked="" type="checkbox"/> UNCLASSIFIED/UNLIMITED <input checked="" type="checkbox"/> SAME AS RPT <input type="checkbox"/> DTIC USERS		Unclassified	
22a NAME OF RESPONSIBLE INDIVIDUAL		22b TELEPHONE (Include Area Code)	
Lang-Mann Chang		(301) 278-6107	
		22c OFFICE SYMBOL	
		SLCBBR-IB-P	

ABSTRACT (continued)

the vigorous combustion zone in the initial ignition site. Recommendations have been made to modify the primer and more testings are underway to optimize the ignition system for the 5-in./54 LOVA charge.

TABLE OF CONTENTS

	Page
LIST OF FIGURES.....	5
I. INTRODUCTION.....	7
II. EXPERIMENTAL APPARATUS.....	9
III. RESULTS AND DISCUSSION.....	9
A. Ignition of Primers in Empty Chambers.....	11
B. Ignition of Primers in Inert Propellant Packed Chambers.....	13
C. Test Firings of Live Charges.....	15
IV. SUMMARY AND CONCLUSIONS.....	20
V. RECOMMENDATIONS.....	21
ACKNOWLEDGMENTS.....	22
REFERENCES.....	23
DISTRIBUTION LIST.....	25

Accession For	
NTIS GRA&I	<input checked="" type="checkbox"/>
DTIC TAB	<input checked="" type="checkbox"/>
Unannounced	<input type="checkbox"/>
Justification	
By _____	
Distribution/	
Availability Codes	
Dist	Avail and/or Special
A-1	



# I. INTRODUCTION

The current demand for increased weapon system survivability has focused attention on the use of insensitive propellants (LOVA) as a means of reducing system vulnerability. The U.S. Navy has made considerable effort in developing such propelling charges for the 5-in./54 gun system. In this development program, during gun firing tests two rounds with LOVA (Lot 2163BL) charges which had only small difference in charge weight (9.45 kg vs. 9.68 kg) showed a dramatic difference in their pressure data. Both rounds used the MK 45 Mod 1 primer. Figure 1 and Figure 2 present the pressure histories monitored at four locations along the gun barrel in the two rounds. The differential pressure  $dP (=P_{464\text{-mm}} - P_{895\text{-mm}})$  was also shown, where  $P_{464\text{-mm}}$  and  $P_{895\text{-mm}}$  were the pressures monitored at 464 mm and 895 mm from the breech end, respectively. The peak pressure reached 310 MPa (45 kpsi) in the first round and 648 MPa (94 kpsi) in the second round. In addition, the pressure curves for the high pressure round exhibited several pressure steps before reaching their peak values. From the  $dP$  curve in Figure 2 it is apparent that high amplitude pressure waves formed and the waves traveled back and forth in the gun chamber before the projectile exited the barrel. Investigations to determine the cause of the inconsistent interior ballistic results and the

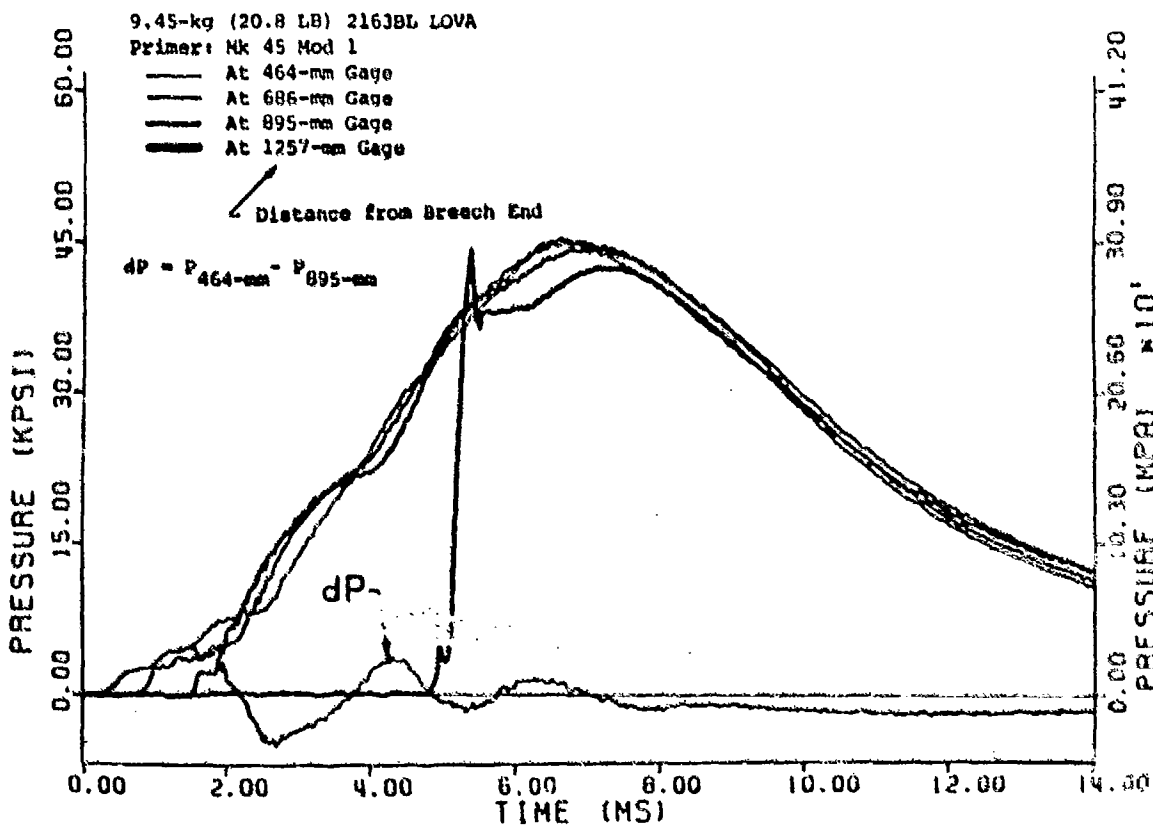

Figure 1. Pressure Data Recorded in Gun Firing Test (5-in./54 LOVA/2163BL Charge, Round No. 1)

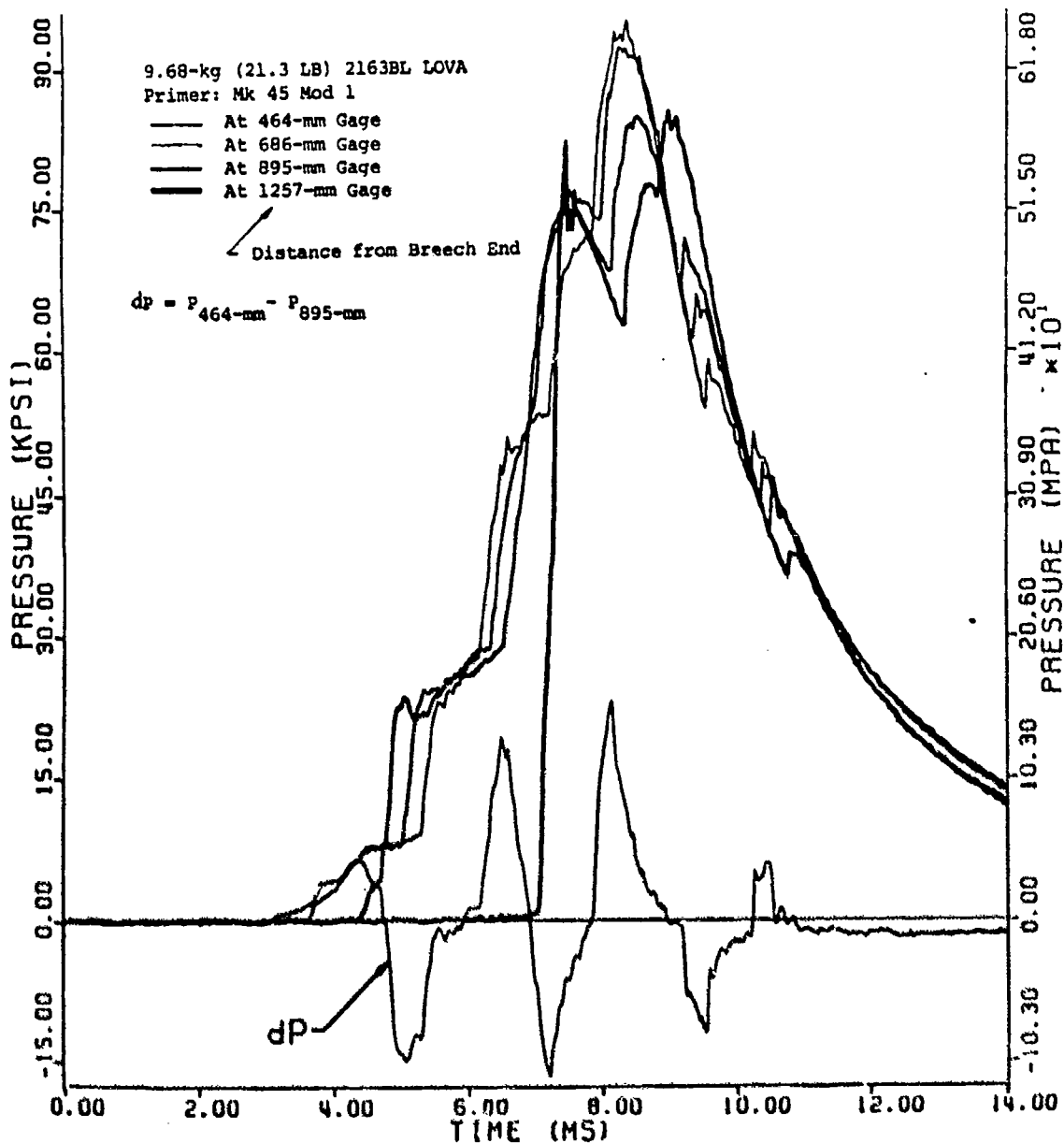

Figure 2. Pressure Data Recorded in Gun Firing Test  
(5-in./54 LOVA/2163BL Charge, Round No. 2)

unusual pressure behavior on these rounds were obviously necessary before conducting further gun firing tests with LOVA charges. With its experience in gun simulator diagnostics, the U.S. Army Ballistic Research Laboratory (BRL) was requested to join with the Navy Naval Ordnance Station at Indian Head, Maryland to pursue the investigation effort.

## II. EXPERIMENTAL APPARATUS

Figure 3 shows a cutaway view of the gun simulator for the present study. The simulator chamber which was made from a transparent acrylic tube was adapted to a breech block at one end and to a short gun tube at the other end. The gun tube was cut from an actual 105-mm tank gun. The projectile had a flat base and would move when the chamber pressure rose to a certain level. There were no filler elements between the projectile base and the propellant bed. The simulator chamber had an inner geometry and dimensions close to that of the 5-in./54 gun chamber and was capable of withstanding pressures in excess of 15 MPa before it ruptured. Two 16-mm high-speed cameras (Photec) with a framing capability of 10,000 pictures per second were employed for recording the flamespread along the chamber length. Three piezoelectric pressure transducers (PCB model 113A23) were installed for monitoring the chamber pressure, two in the breech end and one in the projectile base. In addition, a linear displacement gage was attached to the forward end of the projectile to record the projectile motion. The firing control and data acquisition required were performed by using the Ballistic Data Acquisition System at Range 18 of the BRL.

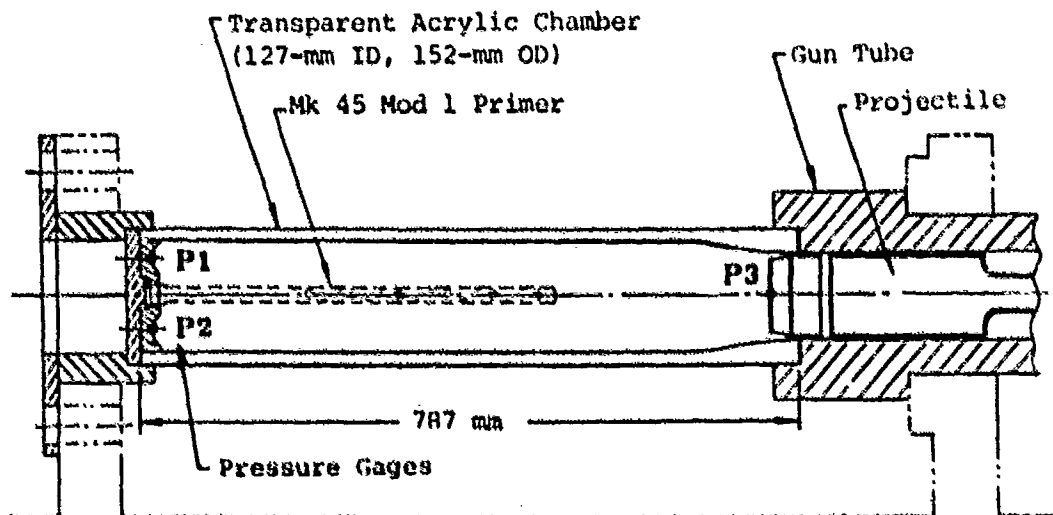

Figure 3. 5-in./54 Gun Simulator

## III. RESULTS AND DISCUSSION

In this study, six rounds were fired with the simulator. The ignition system used throughout was the MK 45 Mod 1 primer loaded with 52 grams of Class 2 black powder. The test plan was as follows: two rounds with ignition of the primer in an empty chamber, two rounds with ignition of the primer in an inert propellant packed chamber, and the final two rounds with live LOVA (Lot 2163BL) propellant. This test arrangement allowed us to examine in detail the functioning of the ignition system, ignition of propellant,

pressure behavior, and dynamic bed rheology occurring during the early phase ballistic cycle. In the inert and live rounds, the chamber was fully filled without apparent ullage.

The following table presents a comparison of the dimensions and mechanical properties of the propellant grains used in the firings. The grain size of the inert propellant was slightly smaller than that of the live LOVA propellant. Both were seven-perforation cylindrical geometry.

As shown in Figure 4, the primer had a total length of 542 mm (21.35 inches) with an unvented section of 235 mm (9.25 inches) from its rear end. The forward end of the primer was sealed by a paper card board. The vented section was located near the central portion of the cartridge chamber. Thus if venting was uniformly distributed along the vented section, even flame-spreading toward the two ends of the propellant bed would result.

Dimensions and Mechanical Properties  
of Inert and Live Propellant Grains

	<u>LOVA/2163BL Grains</u>	<u>Inert Propellant Grains</u>
Geometry	Cyl, 7P	Cyl, 7P
Grain Length (mm)	17.22	15.75
Grain Dia. (mm)	8.46	7.87
Dia. of Perf. (mm)	0.91	0.79
Web (mm)	1.44	1.38
Stress of Failure (MPa)	83.50	102.00
Strain of Failure (%)	3.0	4.7
Strain Rate (second <sup>-1</sup> )	250.0	300.0
Modulus of Elasticity (GPa)	5.07	3.62

Note: The above mechanical properties were obtained from the test results of Robert Lieb of BRL.

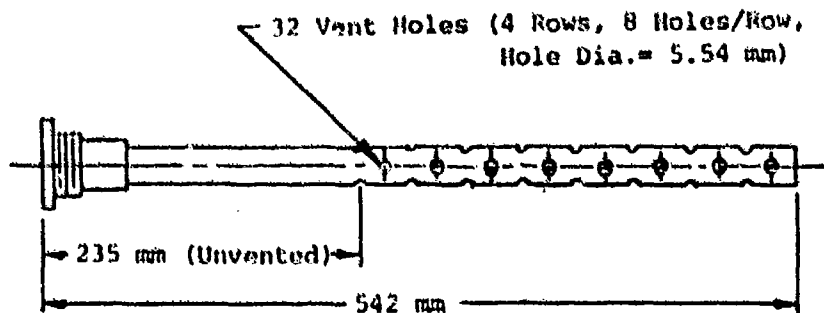

Figure 4. Schematic of Mk 45 Mod 1 Primer

### A. Ignition of Primers in Empty Chambers

Two rounds were fired with a MK 45 Mod 1 primer ignited in an empty simulator chamber. The first round was designed for system checkout, and unfortunately no reliable data were obtained. The firing of the second round was successful. Figure 5 presents the pressure curve recorded by one of the two pressure gages installed in the breech end of the empty chamber. The time coordinate in the figure represents the time after application of the firing voltage. The early pressure rise was extremely steep and fluctuated in amplitude. Previous results in tank gun simulator tests with benite primers did not display such severe phenomena.<sup>1,2</sup> The steep pressure rise indicates that the venting of igniter gases started abruptly. The fluctuation of the curve was a result of the wave reflection between the two ends of the chamber. The time interval between two adjacent pressure peaks was 2.3 ms which was in the same magnitude of the time needed for a sound wave to travel from one end to the other end of the chamber.

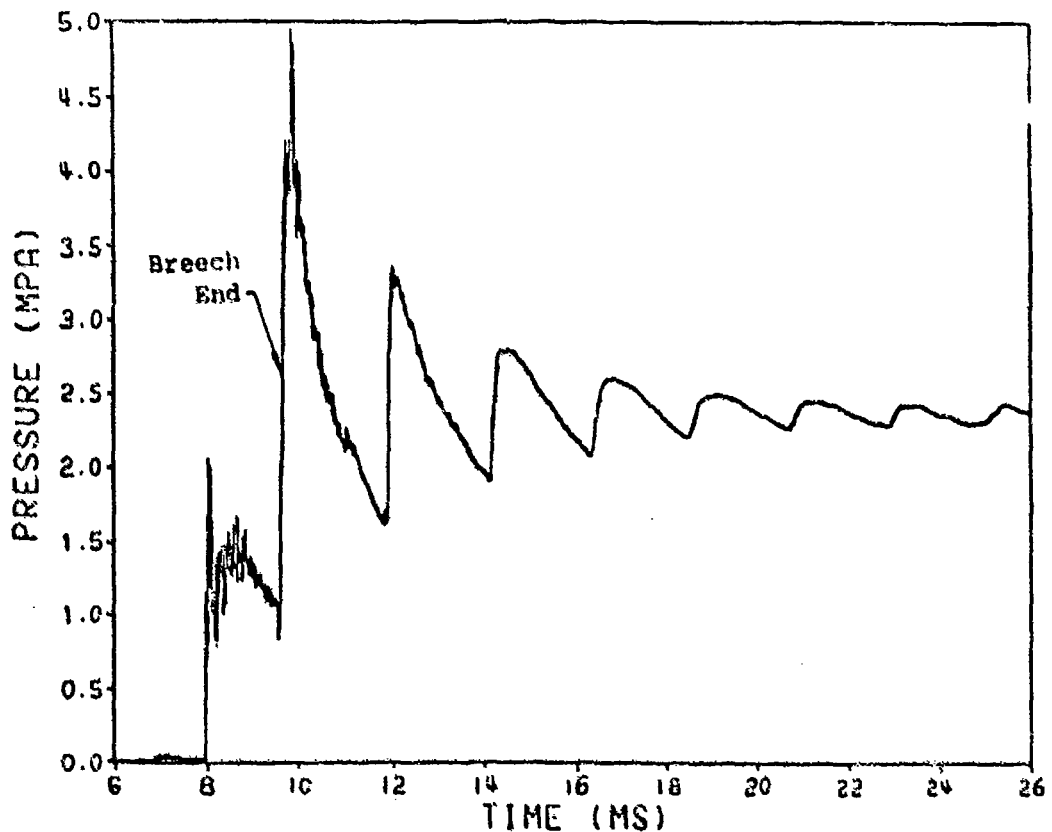

Figure 5. Pressure Data for Primer Ignition in an Empty Chamber

<sup>1</sup>L.M. Chang and J.J. Rocchio, "Early Phase Interior Ballistic Cycle Studies in a Tank Gun Simulator," Proceedings of the 8th International Symposium on Ballistics, pp. I-13 - I-24, Oct 1986.

<sup>2</sup>L.M. Chang, J. Grosh, and R.W. Deas, "Ignition Studies with Two-Piece Cartridges for the 120-mm Lightweight Gun System," Submitted for presentation at the 1987 JANNAF Propulsion Meeting, San Diego, CA, Dec 1987.

Furthermore, the mean value of the fluctuating pressure quickly reached the final maximum chamber pressure 2.25 MPa. This could mean that the majority of the energy in the primer was released in a very short period of time.

Figure 6 shows schematics of the flamespreading occurring in the simulator chamber as observed on the high-speed film. In the figure the times are

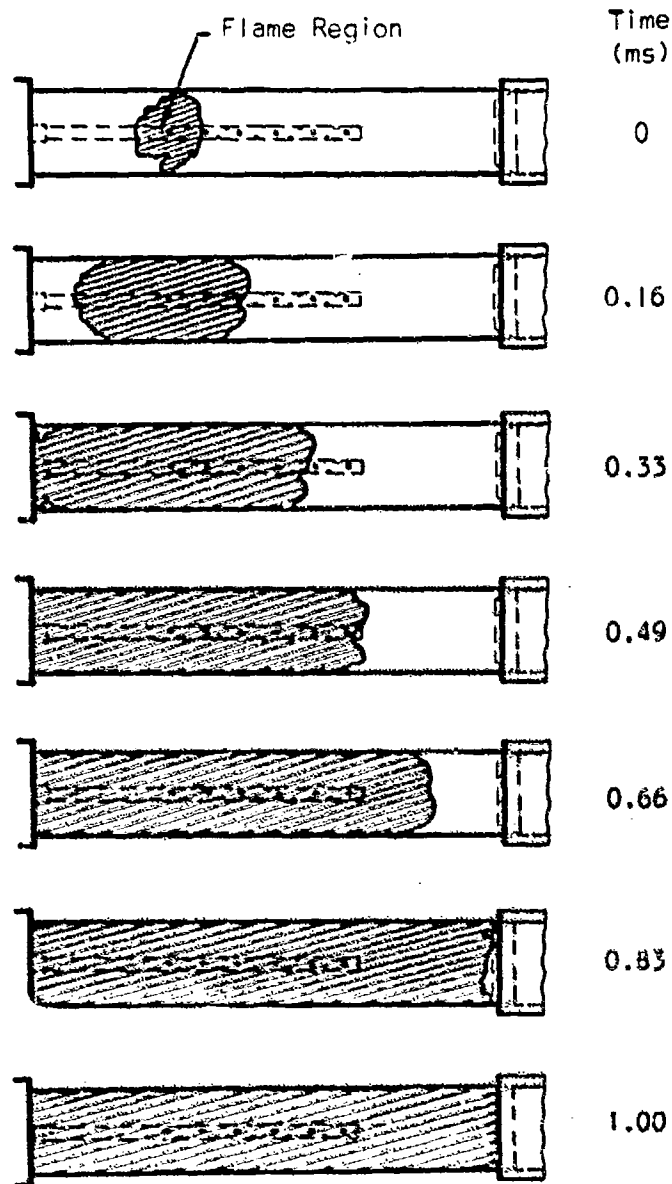

The times are referenced to the instant that the flame was first seen.

Figure 6. Flamespreading for Primer Ignition in an Empty Chamber

referenced to the instant that the flame was first seen. The flamespreading initiated from the region where the first few vent holes closest to the rear end of the primer were located. During the flamespreading period, no significant venting was observed along the remaining section of the primer tube. In fact, the symmetry of the flamespreading toward the two ends of the chamber is also a strong indication that the venting was taking place only in a narrow segment of the chamber length. In addition, the film also shows that the flame fronts traveled back and forth between the chamber ends, concurrent with the fluctuation of the pressure curves in Figure 5. The visible flame endured more than 20 ms before it diminished.

#### B. Ignition of Primers in Inert Propellant Packed Chambers

While the previous firings with empty chambers allow us to observe the venting of igniter gases in detail, the firings with inert propellant packed chambers provide us another set of important information. This includes the intensity of venting, amount of propellant covered by igniter gases, dynamic rheology of the bed, and chamber pressure rise without ignition of propellant. Some of these data cannot be obtained in firings with live charges.

Although a pressure gage failure was encountered in the first of the two rounds fired, the high-speed film provided good photographic data of flamespreading. The first frame in Figure 7 shows that the venting of igniter gases initiated in the same location as observed in the case with the empty chamber. Post firing examination found that approximately 0.5 kg of grains in the strong venting region fractured to various degrees, some in the form of powder, see Figure 8. A number of fractured grains also appeared near the projectile base as well as at the breech end. Such grain fracture is expected to occur also in live LOVA charges since the above table shows that the mechanical properties of the inert propellant and the LOVA propellant fired were similar.

In the second round packed with inert propellant, the chamber ruptured. This is extremely unusual since the inert propellant did not burn and the pressure rise due to the ignition of the primer is normally far below the limit that the chamber can withstand (normally, greater than 10 MPa).<sup>1,2,3</sup> The cause of the rupture can be explained by examining the following pressure and photographic data.

Figure 9 exhibits the pressure rises at the breech and at the forward ends of the chamber. It is noted that the peaks of the pressures in the figure arrived immediately after the chamber ruptured. The curves show that the forward pressure rose very rapidly and overrode the breech pressure before the chamber ruptured. Apparently, there was severe localized pressurization taking place near the forward end of the chamber. To determine the reason we have to examine the photographic evidence of the flamespreading.

---

<sup>3</sup>L.M. Chang and J.J. Rocchio, "Simulator Diagnostics of Early Ignition Phenomena in a 120-mm Tank Gun Propelling Charge," Proceedings of the 9th International Symposium on Ballistics, pp. 1-90 - 1-102, Apr 1986.

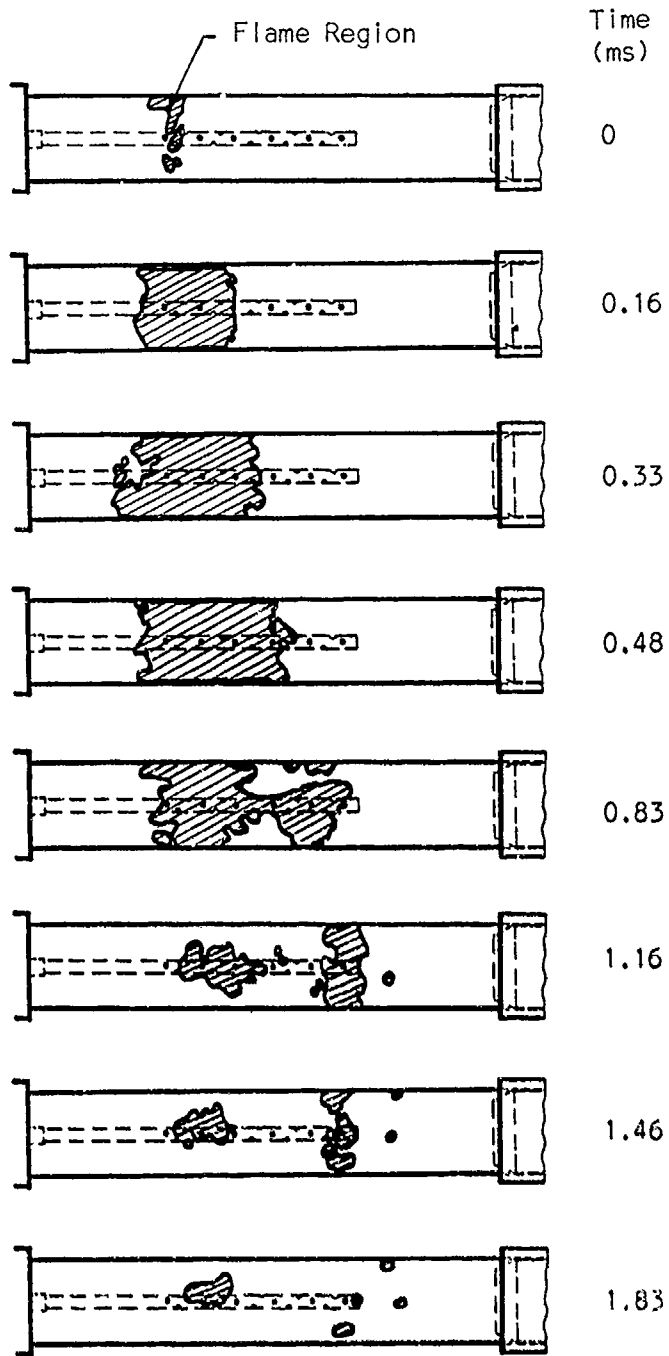

Figure 7. Flamespreading for Primer Ignition in the First Inert Propellant Packed Chamber

Fractured Inert  
Propellant Grains



Figure 8. Fractured Inert Propellant Grains

Despite the failure of the first camera, the flamespreading recorded by the second camera, which viewed approximately two thirds of the chamber length from the breech end, still provides us sufficient information. Figure 10, directly traced from the high-speed film taken by the second camera, shows that the venting started in the region of the first two vent holes. Then a second flame appeared in the region where the forward end of the primer was located. We note that the forward end of the MK 45 Mod 1 primer is sealed by a paper plug only, which cannot hold a high pressure before being ejected. Thus we believe that in this round a large amount of the black powder came out the primer tube following the end plug and subsequently ignited. The ignition caused an abrupt local pressure rise which exceeded the strength limit of the chamber wall. The initiation of chamber rupture in front of the primer tube can be clearly identified on the high-speed film. Such an abnormal venting procedure also can induce pressure waves in gun firings.

#### C. Test Firings of Live Charges

In the two rounds fired with live charges, the pressure and photographic data obtained show good reproducibility, as seen when comparing Figure 11 with Figure 12 and comparing Figure 13 with Figure 14. We see that the breech pressure was much higher than the pressure at the forward end of the chamber. Furthermore, the peak pressure at the breech occurred substantially earlier (more than 0.6 ms) than at the forward end. The implication is clear that the pressure was extremely localized near the breech. Both Figures 13 and 14 indicate that the ignition started in the same region as observed in the inert beds and empty chambers presented earlier. In the same pattern, the flame spread symmetrically toward the two ends of the chamber. Before the flame front reached the projectile base, the chamber ruptured. The location where the rupture initiated is concurrent with the region where the pressure was the highest. After firing, a number of fractured grains (some in the form of powder) were found remaining in the gap between the projectile and the forcing cone of the gun barrel, as shown in Figure 15. Similar fractured grains were also seen at the breech end.

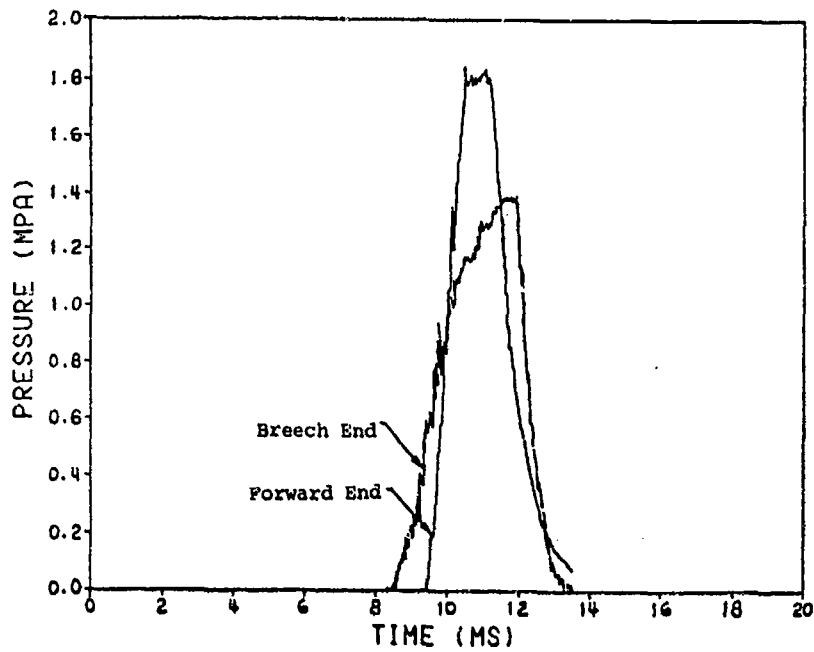

Figure 9. Pressure Data for Primer Ignition in the First Inert Propellant Packed Chamber

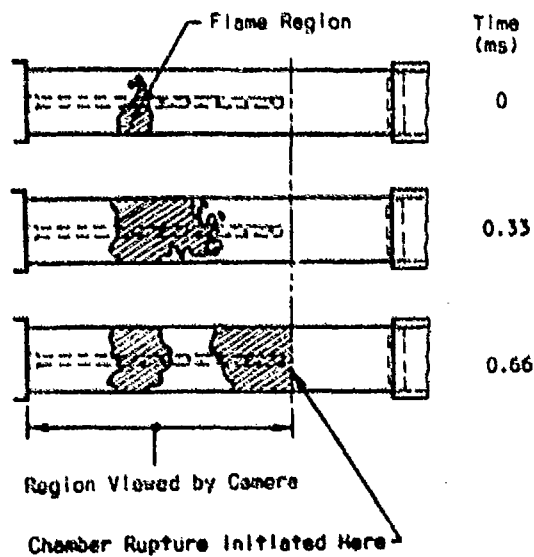

Figure 10. Flamespreading for Primer Ignition in the Second Inert Propellant Packed Chamber

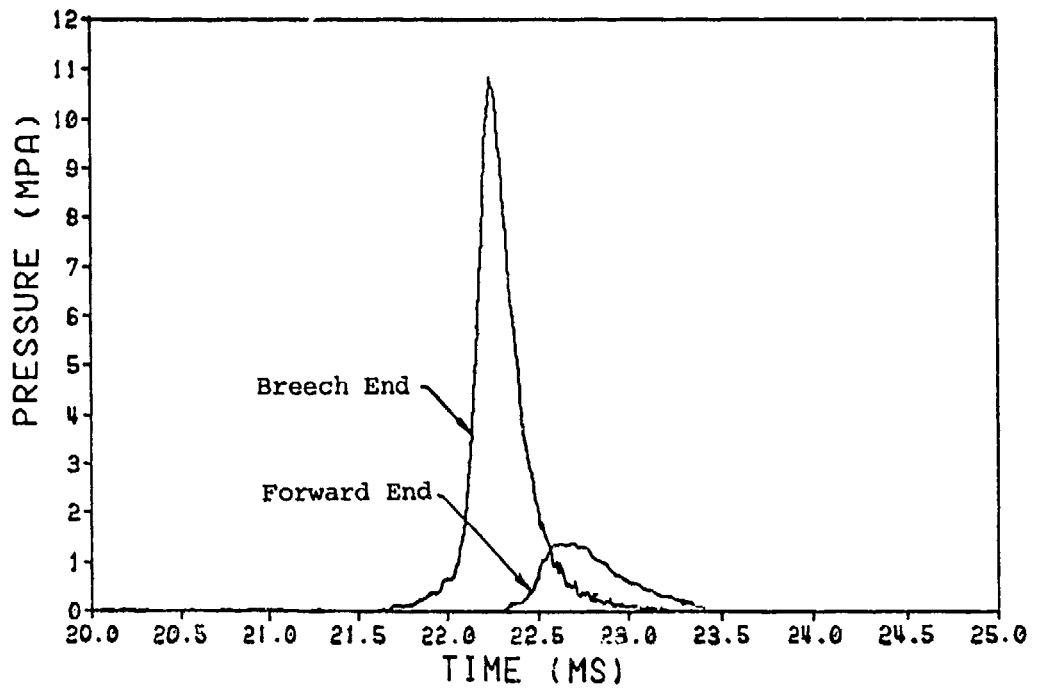

Figure 11. Pressure Data for the First Live Charge

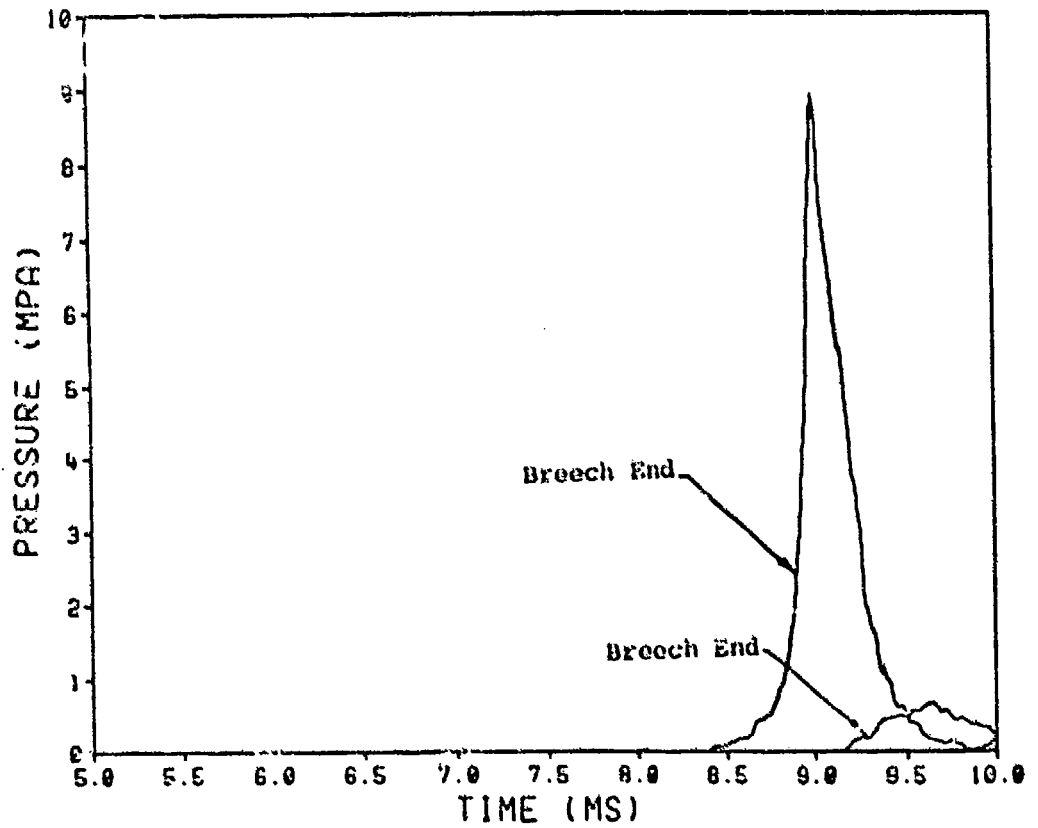

Figure 12. Pressure Data for the Second Live Charge

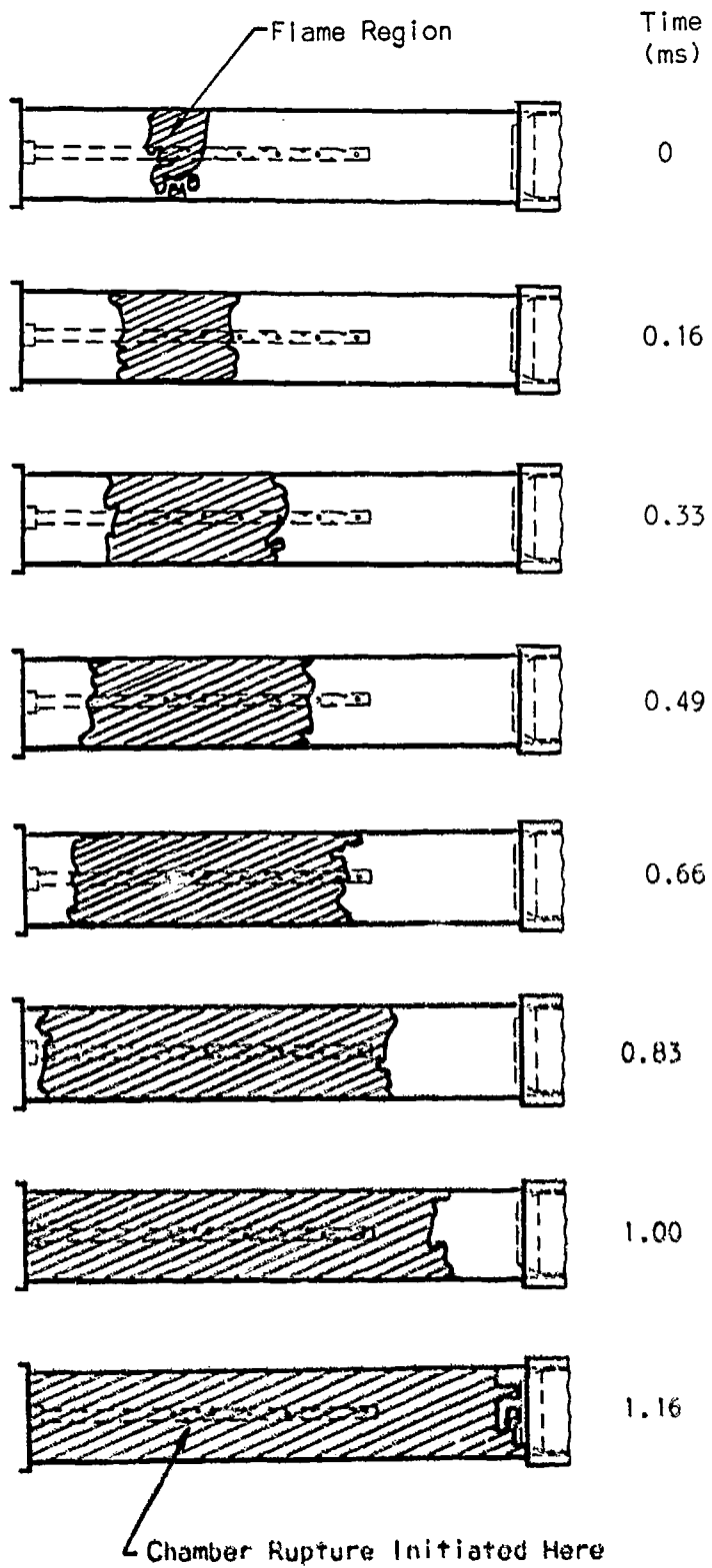

Figure 13. Flamespreading for the First Live Charge

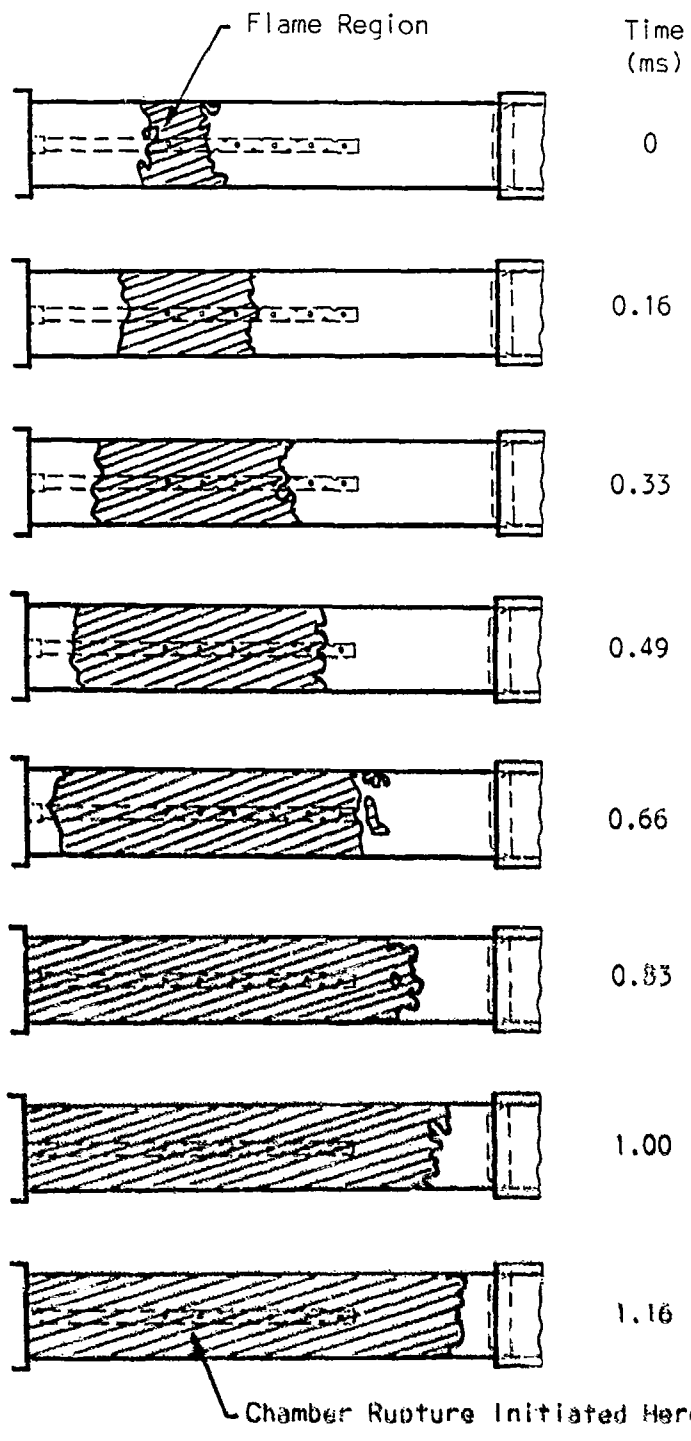

Figure 14. Flamespreading for the Second Live Charge

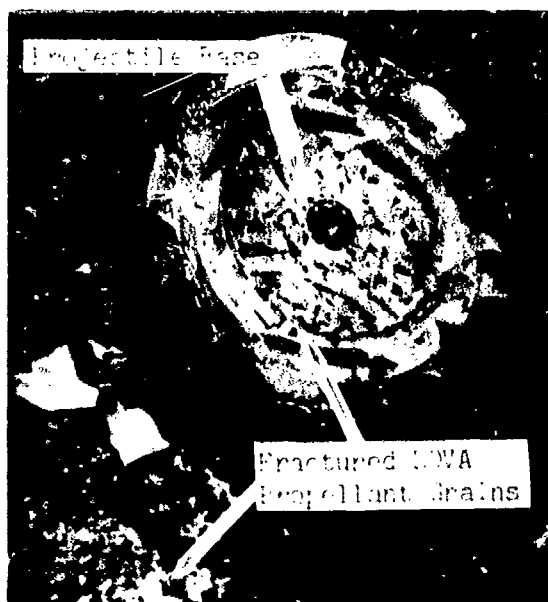

Figure 15. Fractured LOVA Propellant Grains

#### IV. SUMMARY AND CONCLUSIONS

Ignition studies were conducted systematically with ignition of the MK 45 Mod 1 primer in empty chambers, then in inert propellant packed chambers, and finally with live LOVA charges. The emphasis of the studies was on the flamespreading and pressure rise in the propelling charge.

The primer is designed to provide uniform ignition of propellant in the cartridge, i.e., simultaneous ignition along the primer tube length. However, the present test results show that the primer did not function this way. Photographic data clearly indicate that the venting at the rear section of the primer tube predominated. Such an uneven venting distribution will introduce localized ignition and thus is enough to induce pressure waves. This localized venting is likely due to the granular black powder igniter which provides very limited path for flamespreading along the length of the primer tube.

In one of the rounds fired with inert propellant, a second flame region was observed at the forward end of the primer. Post firing examination found that the forward plug was lost. Thus the second flame is believed to be created by the ignition of a large amount of black powder ejected from the primer end. The local pressure rise was so rapid and so high that it ruptured the simulator chamber, which rarely occurred in past firings when only a primer was used. The loss of the forward plug could account for great variability in ballistic performance in guns.

The output rate of the MK 45 Mod 1 primer was so large that grain fracture actually occurred in the venting area and at the forward end as well as at the breech end of the inert and live LOVA propellant beds. Bed compaction seems to be responsible for the fracture. The grain fracture would contribute to the magnitude of the pressure waves recorded in the gun firings.

Based on these results, we conclude that the occurrence of the high amplitude pressure waves and the great variability of the ballistic performance experienced in the gun firing tests were due to one or more of the following three factors:

1. Localized venting of the primer near the breech - inducing localized ignition of the LOVA propellant.
2. Output rate of the primer was too large - causing bed compaction and grain fracture.
3. Loss of the primer end plug - inducing localized ignition of the propellant in front of the primer tube.

#### V. RECOMMENDATIONS

Upon the completion of this test program, several recommendations were made to improve the performance of the ignition system. First, adopt benite strands as substitute of black powder as igniter material. Benite strands have satisfactorily been used in many kinds of bayonet-type primers for standard and LOVA charges for Army tank guns. It has long been recognized that the benite primer has a very favorable flow characteristic of low resistance to the transport of the hot gas generated in the booster to the forward end of the primer. Thus it can provide more uniform venting of igniter gases along the primer tube and consequently more uniform ignition of propellant in the gun chamber. Second, extend the length of the primer tube from 542 mm (21.3 inches) to 635 mm (25 inches) to cover almost full length of the propellant bed. Third, use a metal end plug to prevent the benite strands from coming out the tube. Forth, increase the number of vent holes and to reduce the hole diameter, while the total vent area on the primer tube in a given length remains the same. This is designed to initially ignite more propellant surrounding the primer and to maintain a high output rate of igniter gases for a longer period of time during the early venting process. The reasons have been explained more fully in Reference 4. Primers of this design have been demonstrated to be effective in ignition of LOVA propellants in tank gun systems.<sup>4,5,6</sup>

---

<sup>4</sup>L.M. Chang, "Early Phase Ignition Phenomena Observed in a 105-mm Tank Gun Chamber," 21st JANNAF Combustion Meeting, CPIA publication 412, Vol. II, pp. 301-311, Oct 1984.

<sup>5</sup>L.M. Chang, K.P. Resnik, and J.J. Rocchio, "Ignition Studies for Charge Development for an Advanced 105-mm Kinetic Energy Cartridge," 23rd JANNAF Combustion Meeting, CPIA Publication 457, Vol. II, pp. 297-306, Oct 1986.

<sup>6</sup>Kevin P. Resnik, "Charge Development of High Energy Nitramine Composite Propellant (HELOVA) for an Advanced 105-mm Kinetic Energy Cartridge," 23rd JANNAF Combustion Meeting, CPIA Publication 457, Vol. II, pp. 319-327, Oct 1986.

Test firings with the improved primer designs have been conducted in the simulator. The results show great improvements in the uniformity of venting of igniter gases and the pressure distribution in the simulator chamber. Efforts are underway in the Navy to optimize the primer configuration and to select appropriate igniter material for the primer. Results will be reported as soon as the simulator tests for the new ignition systems are completed.

#### ACKNOWLEDGMENTS

The author wishes to thank Mr. Kirk Rice at the Naval Ordnance Station, Indian Head, MD, for his assistance in providing the primers and the gun firing test data used in this investigation. The author also wishes to thank Messrs. J. Evans, J. Bowen, J. Hewitt, and J. Stabile for assistance in conducting the firing program.

## REFERENCES

1. L.M. Chang and J.J. Rocchio, "Early Phase Interior Ballistic Cycle Studies in a Tank Gun Simulator," Proceedings of the 8th International Symposium on Ballistics, pp. I-13 - I-24, Oct 1984.
2. L.M. Chang, J. Grosh, and R.W. Deas, "Ignition Studies with Two-Piece Cartridges for the 120-mm Lightweight Gun Systems," submitted for presentation at the 1987 JANNAF Propulsion Meeting, San Diego, CA, Dec 1987.
3. L.M. Chang and J.J. Rocchio, "Simulator Diagnostics of Early Ignition Phenomena in a 120-mm Tank Gun Propelling Charges," Proceedings of the 9th International Symposium on Ballistics, pp. 1-91 - 1-102, Apr 1986.
4. L.M. Chang, "Early Phase Ignition Phenomena Observed in a 105-mm Tank Gun Chamber," 21st JANNAF Combustion Meeting, CIPA Publication 412, Vol. II, pp. 301-311, Oct 1984.
5. L.M. Chang, K.P. Resnik, and J.J. Rocchio, "Ignition Studies for Charge Development for an Advanced 105-mm Kinetic Energy Cartridge," 23rd JANNAF Combustion Meeting, CIPA Publication 457, Vol. II, pp. 307-316, Oct 1986.
6. Kevin P. Resnik, "Charge Development of High Energy Nitramine Composite Propellant (HELOVA) for an Advanced 105-mm Kinetic Energy Cartridge," 23rd JANNAF Combustion Meeting, CIPA Publication 457, Vol. II, pp. 319-327, Oct 1986.

DISTRIBUTION LIST

<u>No. Of</u> <u>Copies</u>	<u>Organization</u>	<u>No. Of</u> <u>Copies</u>	<u>Organization</u>
12	Administrator Defense Technical Info Center ATTN: DTIC-DDA Cameron Station Alexandria, VA 22304-6145	5	Project Manager Cannon Artillery Weapons System, ARDEC, AMCCOM ATTN: AMCPM-CW, F. Menke AMCPM-CWW AMCPM-CWS, M. Fisette AMCPM-CWA
1	Commander USA Concepts Analysis Agency ATTN: D. Hardison 8120 Woodmont Avenue Bethesda, MD 20014-2797		R. Dekleine H. Hassmann Dover, NJ 07801-5001
1	HQDA/DAMA-ART-M Washington, DC 20310-2500	20	Commander US Army ARDEC, AMCCOM ATTN: SMCAR-TSS SMCAR-TDC SMCAR-LC LTC N. Barron SMCAR-AEE-BP A. Beardell D. Downs S. Einstein S. Westley S. Bernstein C. Roller J. Rutkowski SMCAR-LCB-I D. Spring SMCAR-LCE SMCAR-LCM-E S. Kaplowitz SMCAR-LCS SMCAR-CCH-T E. Barrieres R. Davitt SMCAR-LCU-CV C. Mandala SMCAR-LCW-A M. Salsbury SMCAR-AEE-BP L. Stiefel B. Brodaman Dover, NJ 07801-5001
1	HQDA/DAMA-CSM Washington, DC 20310-2500		
1	HQDA/SARDA Washington, DC 20310-2500		
1	Commander US Army War College ATTN: Library-FF229 Carlisle Barracks, PA 17013		
1	US Army Ballistic Missile Defense Systems Command Advanced Technology Center P.O. Box 1500 Huntsville, AL 35807-3801		
1	Chairman DOD Explosives Safety Board Room 856-C Hoffman Bldg. 1 2461 Eisenhower Avenue Alexandria, VA 22331-9999		
1	Commander US Army Material Command ATTN: AMCPM-WF 5001 Eisenhower Avenue Alexandria, VA 22331-5001		
1	Commander US Army Material Command ATTN: AMCDRA-ST 5001 Eisenhower Avenue Alexandria, VA 22331-5001	2	Project Manager Munitions Production Base Modernization and Expansion ATTN: AMCPM-PBM, A. Siklosi AMCPM-PBM-E, L. Laibson Dover, NJ 07801-5001

DISTRIBUTION LIST

<u>No. of Copies</u>	<u>Organization</u>	<u>No. of Copies</u>	<u>Organization</u>
3	Project Manager Tank Main Armament System ATTN: AMCPM-TMA, K. Russell AMCPM-TMA-105 AMCPM-TMA-120 Dover, NJ 07801-5001	1	Commander US Army Communications - Electronics Command ATTN: AMSEL-ED Fort Monmouth, NJ 07703-5301
1	Commander US Army Watervliet Arsenal ATTN: SARWV-RD, R. Thierry Watervliet, NY 12189-5001	1	Commander ERADCOM Technical Library ATTN: DELSD-L (Report Section) Fort Monmouth, NJ 07703-5301
4	Commander US Army Armament Munitions and Chemical Command ATTN: SMCAR-ESP-L Rock Island, IL 61299-7300	1	Commander US Army Harry Diamond Lab. ATTN: DELHD-TA-L 2800 Powder Mill Road Adelphi, MD 20783-1145
1	HRDA DAMA-ART-M Washington, DC 20310-2500	1	Commander US Army Missile Command ATTN: AMSMI-CM Redstone Arsenal, AL 35898-5249
1	Director Benet Weapons Laboratory Armament Rech Dep & Eng Center US Army AMCCOM ATTN: SMCAR-CCB-TL Watervliet, NY 12189-5001	1	Director US Army Missile and Space Intelligence Center ATTN: AIAMS-YDL Redstone Arsenal, AL 35898-5500
1	Commander US Army Aviation Research and Development Command ATTN: AMSAV-E 4300 Goodfellow Blvd. St. Louis, MO 63120-1702	1	Commander US Army Missile Command Research, Development, and Engineering Center ATTN: AMSMI-RD Redstone Arsenal, AL 35898-5500
1	Commander US Army TSARCOM 4300 Goodfellow Blvd. St. Louis, MO 63120-1702	1	Commander US Army Aviation School ATTN: Aviation Agency Fort Rucker, AL 36360
1	Director US Army Air Mobility Research and Development Laboratory Ames Research Center Moffett Field, CA 94035-1099	1	Commander US Army Tank Automotive Command ATTN: AMSTA-TSL Warren, MI 48092-2498

DISTRIBUTION LIST

<u>No. of Copies</u>	<u>Organization</u>	<u>No. of Copies</u>	<u>Organization</u>
1	Commander US Army Tank Automotive Command ATTN: AMSTA-CG Warren, MI 48092-2498	2	Commander US Army Materials and Mechanics Research Center ATTN: AMXMR-ATL Tech Library Watertown, MA 02172
1	Project Manager Improved TOW Vehicle ATTN: AMCPM-ITV US Army Tank Automotive Command Warren, MI 48092-2498	1	Commander US Army Research Office ATTN: Tech Library P.O. Box 12211 Research Triangle Park, NC 27709-2211
2	Project Manager M1 Abrams Tank Systems ATTN: AMCPM-GMC-SA, T. Dean Warren, MI 48092-2498	1	Commander US Army Belvoir Research & Development Center ATTN: STRBE-WC Fort Belvoir, VA 22060-5606
1	Project Manager Fighting Vehicle Systems ATTN: AMCPM-FVS Warren, MI 48092-2498	1	Commander US Army Logistics Mgmt Ctr Defense Logistics Studies Fort Lee, VA 23801
1	President US Army Armor & Engineer Board ATTN: ATZK-AD-S Fort Knox, KY 40121-5200	1	Commander US Army Infantry School ATTN: ATSH-CD-CSO-OR Fort Benning, GA 31905
1	Project Manager M-60 Tank Development ATTN: AMCPM-M60TD Warren, MI 48092-2498	1	President US Army Artillery Board Ft. Sill, OK 73503-5600
1	Director US Army TRADOC Systems Analysis Activity ATTN: ATAA-SL White Sands Missile Range, NM 88002	1	Commandant US Army Command and General Staff College Fort Leavenworth, KS 66027
1	Commander US Army Training & Doctrine Command ATTN: ATCD-MA/ MAJ Williams Fort Monroe, VA 23651	1	Commandant US Army Special Warfare School ATTN: Rev & Tng Lit Div Fort Bragg, NC 28307
		3	Commander Radford Army Ammunition Plant ATTN: SNCRA-QA/HI LIB Radford, VA 24141-0298

DISTRIBUTION LIST

<u>No. of Copies</u>	<u>Organization</u>	<u>No. of Copies</u>	<u>Organization</u>
1	Commander US Army Foreign Science & Technology Center ATTN: AMXST-MC-3 220 Seventh Street, NE Charlottesville, VA 22901-5396	1	Assistant Secretary of the Navy (R, E, and S) ATTN: R. Reichenbach Room 5E787 Pentagon Bldg. Washington, DC 20350
2	Commandant US Army Field Artillery Center & School ATTN: ATSF-CO-MW, B. Willis Ft. Sill, OK 73503-5600	1	Naval Research Lab Tech Library Washington, DC 20375
1	Commander US Army Development and Employment Agency ATTN: MODE-TED-SAB Fort Lewis, WA 98433-5099	5	Commander Naval Surface Weapons Center ATTN: Code G33, J. L. East W. Burrell J. Johndrow Code G23, D. McClure Code DX-21 Tech Lib Dahlgren, VA 22448-5000
1	Chief of Naval Material Department of Navy ATTN: J. Amlie Arlington, VA 20360	2	Commander US Naval Surface Weapons Center ATTN: J. P. Consaga C. Gotsmer Indian Head, MD 20640-5000
1	Office of Naval Research ATTN: Code 473, R. S. Miller 800 N. Quincy Street Arlington, VA 22217-9999	4	Commander US Naval Surface Weapons Center ATTN: S. Jacobs/Code 240 Code 730 F. Kim/Code R-13 R. Bernecker Silver Springs, MD 20903-5000
3	Commandant US Army Armor School ATTN: ATZK-CD-MS N. Falkovitch Armor Agency Fort Knox, KY 40121-5215	2	Commanding Officer Naval Underwater Systems Center Energy Conversion Dept. ATTN: Code 5B331, R. S. Lazar Tech Lib Newport, RI 02840
2	Commander Naval Sea Systems Command ATTN: SEA 62R SEA 64 Washington, DC 20362-5101		
1	Commander Naval Air Systems Command ATTN: AIR-954-Tech Lib Washington, DC 20360		



DISTRIBUTION LIST

<u>No. of Copies</u>	<u>Organization</u>	<u>No. of Copies</u>	<u>Organization</u>
10	Central Intelligence Agency Office of Central Reference Dissemination Branch Room GE-47 HQS Washington, DC 20505	2	Director Los Alamos Scientific Lab ATTN: T3, D. Butler M. Division P.O. Box 1663 Los Alamos, NM 87544
1	General Electric Company Armament Systems Dept. ATTN: M. J. Bulman Room 1311 128 Lakeside Avenue Burlington, VT 05401-4985		<u>Aberdeen Proving Ground</u>  Dir, USAMSAA ATTN: AMXSY-D AMXSY-MP, H. Cohen  Cdr, USATECOM ATTN: AMSTE-TO-F AMSTE-CM-F, L. Nealley  Cdr, CSTA ATTN: STECS-AS-H, R. Hendricksen  Cdr, CRDEC, AMCCOM ATTN: SMCCR-RSP-A SMCCR-MU SMCCR-SPS-IL
1	Hercules Inc. Radford Army Ammunition Plant ATTN: J. Pierce Radford, VA 24141-0299		
1	Paul Gough Associates, Inc. ATTN: P. S. Gough P.O. Box 1614 1048 South Street Portsmouth, NH 03801-1614		
1	Princeton Combustion research Lab., Inc. ATTN: M. Summerfield 475 US Highway One Monmouth Junction, NJ 08852-9650		
1	Battelle Memorial Institute ATTN: Tech Library 505 King Avenue Columbus, OH 43201-2693		
1	Johns Hopkins University Applied Physics Laboratory Chemical Propulsion Information Agency ATTN: T. Christian Johns Hopkins Road Laurel, MD 20707-0690		
1	Pennsylvania State University Dept. of Mech. Engineering ATTN: K. Kuo University Park, PA 16802-7501		

USER EVALUATION SHEET/CHANGE OF ADDRESS

This Laboratory undertakes a continuing effort to improve the quality of the reports it publishes. Your comments/answers to the items/questions below will aid us in our efforts.

1. BRL Report Number \_\_\_\_\_ Date of Report \_\_\_\_\_

2. Date Report Received \_\_\_\_\_

3. Does this report satisfy a need? (Comment on purpose, related project, or other area of interest for which the report will be used.) \_\_\_\_\_  
\_\_\_\_\_  
\_\_\_\_\_

4. How specifically, is the report being used? (Information source, design data, procedure, source of ideas, etc.) \_\_\_\_\_  
\_\_\_\_\_  
\_\_\_\_\_

5. Has the information in this report led to any quantitative savings as far as man-hours or dollars saved, operating costs avoided or efficiencies achieved, etc? If so, please elaborate. \_\_\_\_\_  
\_\_\_\_\_  
\_\_\_\_\_

6. General Comments. What do you think should be changed to improve future reports? (Indicate changes to organization, technical content, format, etc.) \_\_\_\_\_  
\_\_\_\_\_  
\_\_\_\_\_

**CURRENT ADDRESS**

Name \_\_\_\_\_  
Organization \_\_\_\_\_  
Address \_\_\_\_\_  
City, State, Zip \_\_\_\_\_

7. If indicating a Change of Address or Address Correction, please provide the New or Correct Address in Block 6 above and the Old or Incorrect address below.

**OLD ADDRESS**

Name \_\_\_\_\_  
Organization \_\_\_\_\_  
Address \_\_\_\_\_  
City, State, Zip \_\_\_\_\_

(Remove this sheet, fold as indicated, staple or tape closed, and mail.)

FOLD HERE

Director  
US Army Ballistic Research Laboratory  
ATTN: DRXBR-OD-ST  
Aberdeen Proving Ground, MD 21005-5066



NO POSTAGE  
NECESSARY  
IF MAILED  
IN THE  
UNITED STATES

OFFICIAL BUSINESS  
PENALTY FOR PRIVATE USE, \$300

**BUSINESS REPLY MAIL**  
FIRST CLASS PERMIT NO 12062 WASHINGTON, DC  
POSTAGE WILL BE PAID BY DEPARTMENT OF THE ARMY

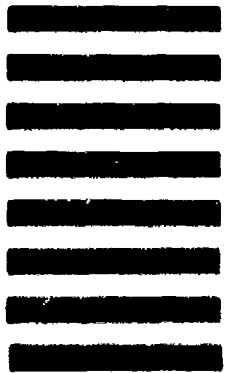

Director  
US Army Ballistic Research Laboratory  
ATTN: DRXBR-OD-ST  
Aberdeen Proving Ground, MD 21005-9989

FOLD HERE