

AD-A187 268

A GENERAL APPLICATION COMPUTER-ASSISTED INSTRUCTION
SYSTEM FOR MICROCOMPUTERS(U) AIR FORCE INST OF TECH
WRIGHT-PATTERSON AFB OH SCHOOL OF SYST. R MASON
SEP 87 AFIT/GLM/LSR/875-45

1/3

UNCLASSIFIED

F/G 12/5

NL

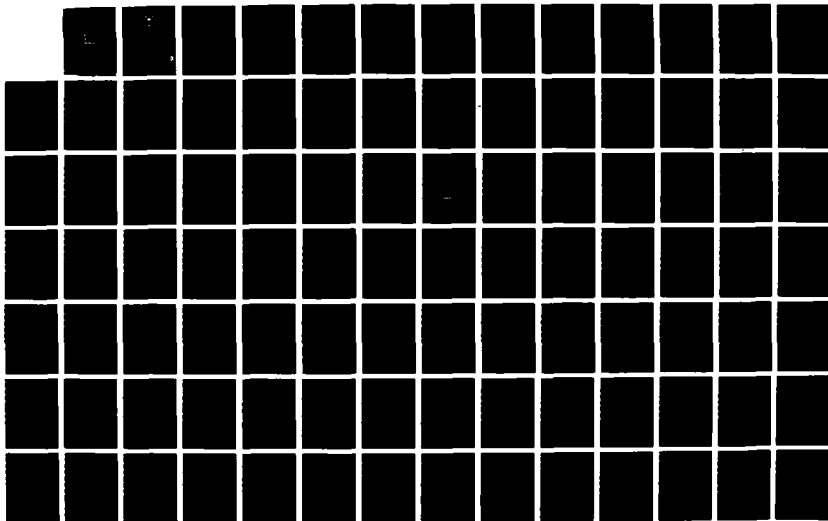

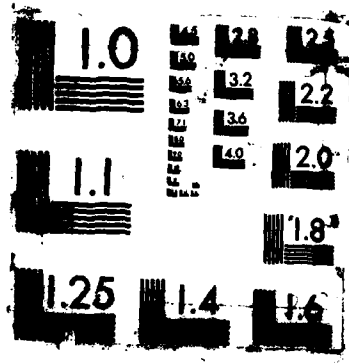

AD-A187 268



A GENERAL APPLICATION COMPUTER-ASSISTED
INSTRUCTION SYSTEM FOR MICROCOMPUTERS

THESIS

Robert Mason
Lieutenant, Supply Corps, USN

AFIT/GLM/LSR/87S-45

DTIC
ELECTE
S JAN 04 1988 D
E

DEPARTMENT OF THE AIR FORCE
AIR UNIVERSITY

AIR FORCE INSTITUTE OF TECHNOLOGY

Wright-Patterson Air Force Base, Ohio

This document has been approved
for public release and sale; its
distribution is unlimited.

87 12 22 05

2

AFIT/GLM/LSR/87S-45

A GENERAL APPLICATION COMPUTER-ASSISTED
INSTRUCTION SYSTEM FOR MICROCOMPUTERS
THESIS

Robert Mason
Lieutenant, Supply Corps, USN

AFIT/GLM/LSR/87S-45

DTIC
SELECTED
S JAN 04 1988 D
E

Approved for public release; distribution unlimited

AFIT/GLM/LSR/87S-45

A GENERAL APPLICATION COMPUTER-ASSISTED
INSTRUCTION SYSTEM FOR MICROCOMPUTERS

THESIS

Presented to the Faculty of the School of Systems and Logistics
of the Air Force Institute of Technology

Air University

In Partial Fulfillment of the
Requirements for the Degree of
Master of Science in Logistics Management

Robert Mason, B.S.

Lieutenant, Supply Corps, USN

September 1987

Approved for public release; distribution unlimited

Preface

The purpose of this study was to provide supply managers with an alternate method of augmenting aviation storekeeper training through the use of computer-assisted instruction on microcomputers. However, this effort evolved into a computer-assisted instruction system with a wide field of application. The system can be used in virtually any subject area to develop, administer, and monitor computer-assisted instruction techniques.

I would like to express my special appreciation to Major John Stibravy for his assistance, understanding, praise, and criticism during development of this training system. In addition to being my capable faculty advisor he was also friend, confidant, and colleague.

I would also like to express my appreciation to my wife and daughters for their understanding and support during the many hours required to complete this project.

Robert Mason

Table of Contents

	Page
Preface	ii
List of Figures	v
Abstract.	vi
I. Introduction.	1- 1
Background.	1- 1
Statement of the Problem.	1- 6
Purpose of the Study.	1- 7
Research Objective Number One.	1- 7
Research Objective Number Two.	1- 7
Research Objective Number Three.	1- 7
Scope and Limitations of the Study.	1- 7
Applicability	1- 8
II. Literature Review	2- 1
Computers in Education and Training	2- 3
Computer-Assisted Instruction Techniques.	2- 8
Advantages and Disadvantages of Computer-Assisted Instruction.	2-11
Computer-Assisted Instruction Systems	2-13
III. Methodology	3- 1
General Method.	3- 1
Specific Procedures	3- 1
Step 1	3- 1
Step 2	3- 2
Step 3	3- 2
Step 4	3- 2
Step 5	3- 3
Step 6	3- 3
IV. System Development.	4- 1
Program Development	4- 1
Documentation Development	4- 7
User's Guide Development.	4- 8

	Page
V. Recommendations	5- 1
Recommendations	5- 1
Recommendation Number One	5- 1
Recommendation Number Two	5- 2
Recommendations for Further Research.	5- 2
Recommendation Number One	5- 2
Recommendation Number Two	5- 2
Recommendation Number Three	5- 2
Recommendation Number Four.	5- 2
Appendix A: LEARNER/BAS Program Documentation.	A- 1
Appendix B: LEARNER/BAS Courseware Example	B- 1
Appendix C: LEARNER/BAS User's Guide	C- 1
Appendix D: WRITE/BAS Program Documentation.	D- 1
Appendix E: WRITE/BAS Courseware Example	E- 1
Appendix F: WRITE/BAS User's Guide	F- 1
Bibliography.	BIB-1
Vita.	VIT-1

List of Figures

Figure	Page
2.1. Computer-Based Education Applications	2- 4
2.2. Computer-Assisted Instruction System Components.	2-14
A.1. LEARNER/BAS Block Diagram	A- 4
B.1. LEARNER/BAS Courseware Example.	B- 2
D.1. WRITE/BAS Block Diagram	D- 4
E.1. WRITE/BAS Main Menu	E- 2
E.2. Creating a Lesson File with WRITE/BAS	E- 3
E.3. Editing a Lesson File with WRITE/BAS.	E-12
E.4. Printing a Lesson File with WRITE/BAS	E-19
E.5. Sample of Printed Lesson File	E-21
E.6. Sample of Printed Student File Report	E-24

Abstract

→ This study provides supply managers with an alternate method of augmenting Naval aviation storekeeper training to improve supply support management at operating sites. A microcomputer-based computer-assisted instruction system was developed which has much broader and significant application. The system can be used in any subject area to develop, administer, and monitor training and is applicable to all Navy, Air Force, Army, and other Department of Defense components. The potential for cost savings and improved operational capability through the use of this system is unlimited.

The system consists of two computer programs written in the BASIC programming language, program documentation, and a user's guide for the system. The system requires a minimum of computer operation knowledge but provides courseware of high quality and flexibility. The system was developed on a Radio Shack, TRS-80, Model 4 microcomputer and converted to operate on a Zenith, Z-248, IBM-AT/PC compatible microcomputer. These

The system creates and administers interactive computer-assisted instruction lessons. Each lesson can consist of any mixture of text screens, multiple choice question screens, and true/false question pages. Variable branching is allowed from question pages depending on student answer input. Lesson size (i.e., number of

screens in a lesson) is limited by program dimensioning to 200 screens and by available disk storage.

The courseware administration program, LEARNER/BAS, displays screens to the student based on courseware branching instructions. The program requires single key input by the student at the end of each screen (continue lesson or answer). On completion of each lesson use, the program records the student's name, date of lesson use, number of questions asked, number of correct/incorrect responses, and incorrect question numbers/incorrect responses to a disk file for analysis and lesson improvement by the courseware author.

The courseware authoring program, WRITE/BAS, is used to generate the text and branching table files for use by the courseware administration program. This program is fully menu driven with on-screen prompts. Using this program, a courseware author can create new lesson files, edit existing lesson files, print lesson files, and print student file reports.

The program documentation is complete so as to allow modifications and enhancements by the user (BASIC programming ability required) based on unique requirements or desires. The user's guide, although short, is complete and reflects the ease of program use and degree of user-friendliness.

A GENERAL APPLICATION COMPUTER-ASSISTED
INSTRUCTION SYSTEM FOR MICROCOMPUTERS

I. Introduction

Background

In 1985, it was discovered on-board the aircraft carrier USS KITTY HAWK that \$14 million worth of supplies could not be accounted for, sailors were able to requisition and receive 31 bars of pure silver, and some \$5 million in F-14 fighter aircraft spare parts had been smuggled from the ship to Iran (17:18). This last incident prompted the Secretary of the Navy, John F. Lehman, Jr., to order an in-house (i.e., Department of the Navy) audit of supply management practices aboard aircraft carriers (7:4). The ensuing audit, conducted by the Naval Audit Service, revealed severe discrepancies in supply management practices aboard the carriers (7:4).

The typical inventory of an aircraft carrier's stock assets can amount to more than \$300 million dollars and can be comprised of over 100,000 line items (4:4). During fiscal year 1985, almost \$320 million in spare parts were improperly accounted for on aircraft carriers (4:4). "Officials since have declared that accountability will be as important as operational capability..." (4:4).

There are many effects of inaccurate inventory records and deficient supply management practices. As stated in a General Accounting Office report concerning an audit of inventory validity at Naval Supply Centers,

Accurate inventory records are essential to the economic and effective supply support of U. S. military forces. Inaccurate records can result in critical supply shortages and prolonged delays in filling requisitions for materiel affecting mission readiness, inflated requests for funds, unnecessary expenditure of funds for procurement and repair of stocks, maldistribution of stocks, and accumulation and disposal of excess stocks. [10:Appendix, 1].

These deficiencies also indicate a loss of accountability for government-owned property and permit, perhaps encourage, outright fraud and use of government property for personal gain.

Among the findings of the Naval Audit Service investigation of aircraft carrier supply management practices, the most significant was the shortage of adequately trained aviation storekeepers aboard the ships (6:1). So significant, in fact, that "the auditors sharply criticized the Navy for permitting carriers to sail with an undermanned, inadequately trained force of aviation storekeepers" (4:4). In January of 1986, carrier manning of paygrade E-6 aviation storekeepers was 63% of that required, and manning of paygrade E-5 aviation storekeepers was 72% of that required (5:2). Actions were subsequently initiated to alleviate this manning shortfall and to upgrade aviation storekeeper training (5:2). "Officials stressed that

efforts to improve carrier supply accounting procedures ... could mean fewer, better trained aviation storekeepers doing the job more effectively..." (5:2).

Aviation storekeepers are the Navy's enlisted occupational specialty for controlling aviation spares. They are responsible for the requisitioning, receipt, storage, inventory control, issue, and shipment of aviation material. They are also responsible for financial accounting of operating funds (flight hour funding and maintenance funding) and for interfacing with organizational and intermediate maintenance level personnel. They must effectively use a variety of manual and automated inventory and maintenance management systems to perform their functions.

Aviation storekeepers receive functional training in a variety of ways. Formal classroom education includes entry level training at Class A schools, advanced technical training at Class C schools, and specialty technical training at Class F schools. Non-classroom training is gained through rate training correspondence courses, on-the-job training, personal qualification standards completion, and self-study of publications contained in the Bibliography for Advancement Study. Ultimate responsibility "to train his subordinates in their own duties and in the duties to which they may succeed" belongs to the division officer (16:89).

Despite the training available, aviation storekeepers are not adequately trained to perform tasks required of them. The reasons for this include differing supply management systems, rapidly changing supply management systems and procedures, the nature of temporary additional duty manning of supply activities, and difficulties in comprehension of supply manuals and directives. Additionally, inadequate manning levels lead to shortfalls in training.

The Navy uses three different supply management mechanized systems and at least three different aviation supply/maintenance mechanized systems (15:Ch 4, 22). Each of these systems is generally in a state of flux with procedural changes caused by program updates or local embellishments. In essence, a senior experienced aviation storekeeper transferred to a new duty station in a supervisory capacity may have little knowledge of the supply management system in use and may require considerable time to develop sufficient knowledge to function effectively.

The problem is compounded by the concept of temporary additional duty manning in aviation support divisions at naval air stations and aboard aircraft carriers. Under this concept, aviation storekeepers are assigned to an aviation squadron and are temporarily assigned to either the naval air station or ship from which the squadron is operating. The intent of this policy is to automatically compensate for the changes in supply workloads brought about by deployment

of an aviation squadron. An aircraft carrier with an embarked air wing will typically have about one-half of the total aviation support division manning comprised of squadron aviation storekeepers who had previously been assigned to perhaps four different naval air station aviation support divisions. Many aviation storekeepers are thus faced with different operating systems, new procedures, and in all probability a new job assignment virtually overnight. The manager is faced with the influx of many new personnel of unknown capabilities and experience. He must incorporate them into his organization and be capable of providing support during high tempo operations instantaneously. The aviation support division's ability to provide a high degree of supply support is critical to the readiness of the embarked aircraft and the warfighting capability of the aircraft carrier. The magnitude of the training problem for these personnel is obvious.

Another factor contributing to inadequate aviation storekeeper training is the readability level of supply manuals and related publications. Although rate training correspondence courses and curricular reading materials are designed with readability in mind, supply publications are not. To an aviation storekeeper of average intelligence, the task of reading and retaining any portion of a lengthy manual written well above his readability level must seem insurmountable. The problem is multiplied if he lacks

adequate reading skills or if English is a second language as is often the case in the aviation storekeeper rating.

Yet another factor contributing to inadequate aviation storekeeper training is the aviation storekeeper manning shortfall itself. Despite its false economy, training is often the first area neglected when manning is inadequate. In an effort to get replacement personnel to a duty station as rapidly as possible, enroute formal schooling may be foregone. When longer working hours are required to perform daily tasks, it is difficult to devote additional hours to formal training or self-study.

The final factor in the aviation storekeeper training "formula for failure" is the self-perpetuating nature of the problem. Senior aviation storekeepers lack the requisite knowledge to properly train subordinates. Performance deficiencies cause errors which must be corrected which require additional expenditure of limited man-hours which leads to further declines in training.

Statement of the Problem

Aviation storekeepers are not adequately trained to perform the tasks they are expected to perform, and currently utilized training methods are not sufficient to provide the required expertise. This affects the quality of supply support afforded an embarked aviation wing and its subsequent operational readiness, which ultimately impacts the carrier's warfighting capability.

Purpose of the Study

The purpose of this study was to provide supply managers with an alternate method of augmenting aviation storekeeper training so as to improve the support and supply management at operating sites. It involved the development of a computer-assisted instruction technique to be applied at the operating site using existing microcomputers and user written training modules. To that end, the following research objectives were established:

Research Objective Number One. Develop a microcomputer program to generate computer-assisted instruction modules for the training of aviation storekeepers. The program should require a minimum of computer programming expertise on the part of the module developer, no programming expertise on the part of the user (i.e., trainee), and be adaptable to a variety of microcomputer types.

Research Objective Number Two. Develop documentation for the computer-assisted instruction programs to permit modification by users if desired.

Research Objective Number Three. Develop user's guides to provide instructions for using the computer-assisted instruction programs.

Scope and Limitations of the Study

With the time and resource limitations for completing this research project, extensive field testing of the programs was not feasible. The programs do permit the

development and administration of computer-assisted instruction courseware. Additional testing could best be accomplished by providing the program and documentation to operating sites for use as desired by management personnel.

The programs developed could not be tested on all possible microcomputers. It was developed and its operation demonstrated on a Radio Shack, TRS-80, Model 4 microcomputer since that machine was readily available to the researcher. To evaluate the programs' transportability, it was subsequently converted and demonstrated on a Zenith, Z-248 microcomputer (IBM AT/PC compatible) since this is rapidly becoming the Department of Defense standard microcomputer. Conversion of the programs to other microcomputers is straightforward with BASIC programming knowledge.

Applicability

Although the motivation for undertaking this research project was to provide supply managers with an alternate method of augmenting aviation storekeeper training, the computer-assisted instruction system which evolved has much broader and significant application. The system can be used in any subject area to develop, administer, and monitor computer-assisted instruction techniques and is applicable to all Navy, Air Force, Army, and other Department of Defense components.

This computer-assisted instruction system was demonstrated to the Air Force Institute of Technology,

School of Systems and Logistics, Department of Exportable Education and is currently under review for use. The potential cost savings from this application alone are substantial. These cost savings would be realized from the following three major advantages of this computer-assisted instruction system:

1. Since many exportable education subjects could be developed for use with this system, travel and lodging at operation sites would be reduced by thousands of dollars annually.
2. Managers at operational sites could administer course material as time and circumstances allow rather than disrupting day-to-day operations for personnel to attend formal classes. With increasing ownership of home computers, effective voluntary training could even occur during off-duty hours.
3. This form of training would be available to operational sites when the need exists -- not only when a site training team can arrange a visit. The addition of this flexibility to meeting training requirements would increase any operating site's effectiveness and contribute to increased combat capability.

Another advantage of this computer-assisted instruction system is the dynamic nature of the programs. The system permits modification to meet individual needs, encourages improvements to the system, and provides feedback mechanisms to courseware authors to allow improvement of courseware material. These modifications and improvements would be shared with other users, thereby increasing the overall effectiveness of the training. Additionally, the potential is unlimited for operating sites to share the courseware developed using the system.

The development of this computer-assisted instruction system affords DOD managers an unheralded degree of flexibility in meeting training requirements while decreasing training costs and increasing training effectiveness. The system enables experts to convey knowledge in a straightforward, simple manner without detriment to daily operations.

II. Literature Review

The computer is incredibly fast, accurate, and stupid. Man is unbelievably slow, inaccurate, and brilliant. The marriage of the two is a force beyond calculation [12:42].

Today's military and civilian managers seem to have taken the above quote (attributed to Leo Cherne, famed economist, lawyer, and sculptor) very much to heart. Computers are used in virtually every facet of administration, planning, and production. Applications include electronic word processing, mechanized supply and inventory records, computer-aided design, computer-aided drafting, mechanized billing, and numerically controlled machines. One application gaining more and more attention in the management world is that of computer-assisted instruction.

Kearsley and Hillelsohn, noted experts in computer-based education, conducted a survey of 200 randomly selected industry training managers to determine the status of computer-based training use. They found that forty-two percent of those responding were using computers in regular training activities and forty-one percent were exploring the use of computers. Computer-based training can be used to teach management/supervision skills, technical tasks, field engineering, policy rating, data processing/programming, new employee orientation, computer-managed instruction, business simulations, process control, equipment maintenance, financial skills, machine operation, computer literacy,

basic skills, and to conduct testing of student progress. From this list, they concluded that "just about any training application is suitable for [computer-based training]" (13:21+).

Dr. Alfred Bork, Director of the Educational Technology Center at the University Of California, Irvine, predicts that "computers will comprise the dominant delivery system in education for almost all age levels in most subject areas" over the next 25 years (2:4). The technological implications of computer learning on education are comparable to those of the invention of the printing press (2:1). However, Dr. Bork is quick to emphasize that each application of computers in educational contexts should be justified since education is not automatically improved using current computer learning methods (2:5).

Based on these observations, it was decided that computer-assisted instruction techniques could be successfully used to augment aviation storekeeper training. However, some background knowledge of the use of computers in education and training is required to effectively apply computer-assisted instruction techniques and to avoid common pitfalls in its use.

The remainder of this chapter provides an introduction to the use of computers in education and training with particular emphasis on computer-assisted instruction techniques. Terms associated with computer-based education are defined and modes of computer-assisted instruction are

described. The advantages and disadvantages of using computer-assisted instruction in training programs are discussed. Considerations of the components of a computer-assisted instruction system (i.e., hardware, software, and courseware) are then presented.

Computers in Education and Training

The computer industry was probably the first group to use computer-based training beginning in the late 1950s (9:20). Although this application was used to teach about computers, the following discussion is applicable to subjects other than the computer itself. Before addressing computer-assisted instruction in particular, a discussion of the uses of computers in education and training and definitions of common terms is warranted.

Figure 2.1 illustrates some of the more common terms used in computer-based education and training. Computer-based education is an "umbrella" term which encompasses all uses of computers in conjunction with education. It is comprised of three major elements - computer-managed instruction, computer-assisted instruction, and computer-supported learning resources. Terms used synonymously for computer-based education include computer-based learning and computer-based training. Computer-based learning is the term most often applied to academic applications while computer-based training is the term most widely accepted in industrial applications.

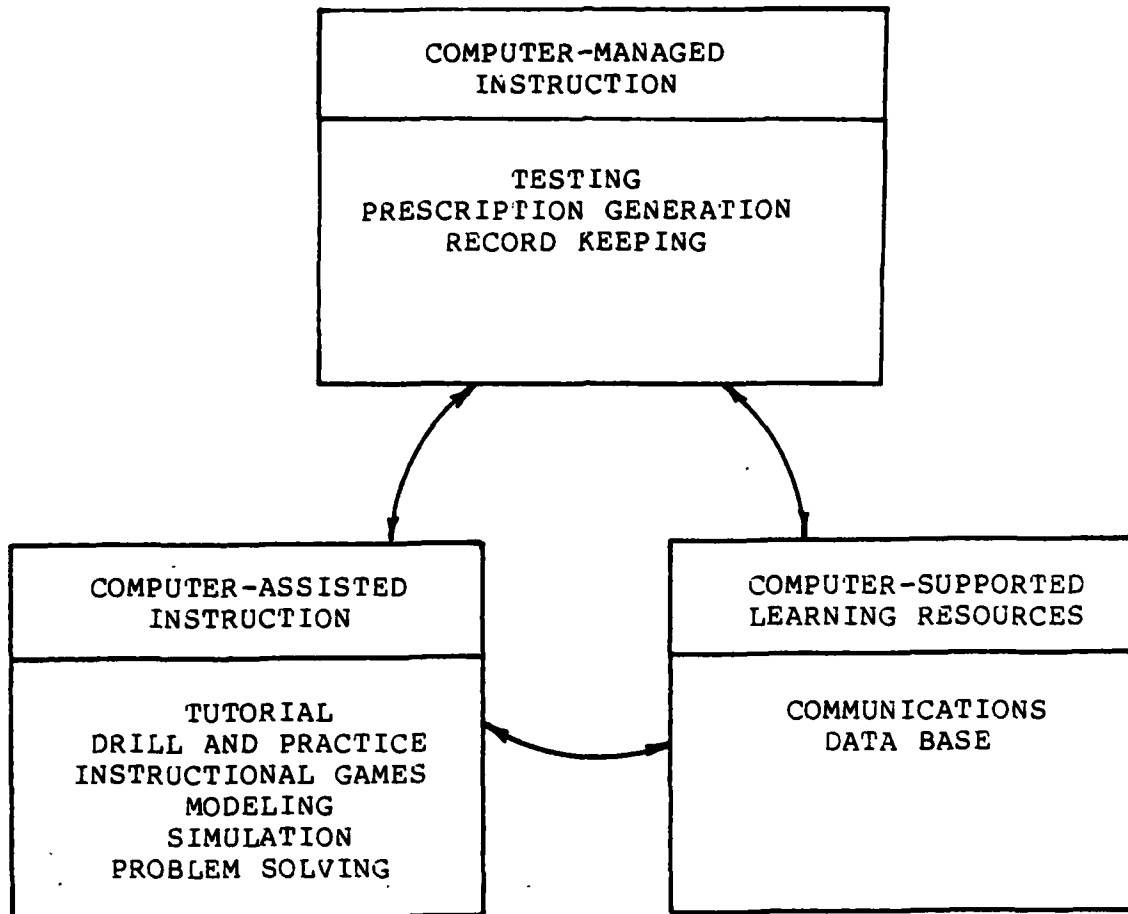

Figure 2.1: Computer-Based Education Applications

Computer-managed instruction is the management of training or education using computer resources. Its use may be invisible to the student as no actual computer interaction is necessary to constitute computer-managed instruction. This use of computers in education consists of three interdependent elements - testing, prescription generation, and record keeping. Testing measures a student's knowledge in a particular subject area (pre-training knowledge) or evaluates a student's comprehension of training objectives (post-training knowledge). Angus Reynolds, a senior human resources development consultant with Control Data Corporation, considers testing the foundation of any computer-managed instructional system since it "provides the information needed to prescribe 'learning activities'" (19:35).

The prescription generation element of computer-managed instruction encompasses the analysis of test results and the determination of what training is required to improve the student's mastery of the subject area. This most frequently means generating a list of training activities (courses, programmed instruction modules, and computer-assisted instruction modules) which the student must complete. This element is the key to computer-managed instruction's power. Each student is required to complete only that training required to attain mastery of the knowledge area.

The record keeping element of computer-managed instruction "automatically generates and stores records of

individual and group progress" (19:35). This record keeping function permits recall, manipulation, and display of data needed to analyze training progress for any selected group. The primary advantages of this element of computer-managed instruction are the elimination of manual record keeping and elimination of printed data which may not be required for analysis.

Computer-assisted instruction is the use of the computer in an actual instructional process (i.e., as an instructional medium). In its simplest form, computer-assisted instruction consists of little more than mechanized programmed instruction. Visual aids afforded by computer graphics range from non-existent to very complex depending on the subject material being taught, the availability of graphics on the computer being used, and the software package used. Current trends in computer-assisted instruction include adoption of multimedia techniques in which the computer is used in conjunction with taped video material, video discs, photographic slides, or other visual material. Computer-assisted instruction techniques will be covered in greater detail in the following section.

Computer-supported learning resources is the term applied to a system for information storage and retrieval (data base) or instructional communications. As such, it neither teaches nor performs management functions. It does, however, permit the exchange of information among users,

sharing of common data among users, and mechanized interaction between instructors and students (19:37).

It should be noted that computer-managed instruction, computer-assisted instruction, and computer-supported learning resources are independent entities which may or may not be used in conjunction with one another. For instance, a computer-managed instructional system can be implemented without students actually using a computer, or computer-assisted instructional techniques can be used without using computer-managed instruction or computer-support learning resources systems. However, the three systems can be easily used together in one large education and training package. As an example, a student may take a test at a computer terminal and have training modules prescribed by the program (computer-managed instruction), complete training modules on the computer (computer-assisted instruction), and receive feed-back from an instructor on the computer (computer-supported learning resource).

Of these three major uses of computers in training, the one most applicable to augmenting aviation storekeeper training is computer-assisted instruction. However, computer-assisted instruction can be applied in a variety of methods as was illustrated in Figure 2.1. Therefore, an in-depth discussion of these methods is warranted.

Computer-Assisted Instruction Techniques

"Computer-assisted instruction grew out of the technology of programmed learning (itself a derivative of the Socratic method, seasoned with Skinner)" (8:22). In one simple form, computer-assisted instruction is little more than a mechanized, programmed instruction in which the student is presented with a portion of text, asked a question about the text he has just read, and a new portion of text is presented based on his answer. Computer-assisted instruction is, however, this and much more. Reynolds lists six distinct modes of computer-assisted instructional techniques - tutorial, drill and practice, instructional games, modeling, simulation, and problem solving (19:35). Each of these methods warrants further discussion.

The tutorial method is that technique described above as an off-shoot of programmed instruction. The primary purpose of this method of computer-assisted instruction is to impart new knowledge to the student. The computer's advantage in presenting this type of material is that it is interactive, requiring participation by the student throughout the training exercise. The student cannot skip portions of text and the program will not advance to the next block of data until the student has demonstrated at least minimal understanding of the material presented.

Drill and practice techniques are most analagous to flash cards or other repetitive exercises. The student is asked a series of questions, the answers are evaluated, and

the student informed of progress throughout the lesson. This technique is most applicable to teaching simple, repetitive skills (mathematics, spelling, and typing) but can be extended to very complex procedures such as maintenance troubleshooting procedures, writing skills, business transaction analysis, and management or supervisory skills. In some computer-assisted instruction programs (especially those dealing with developing basic mathematical skills), the computer attempts to evaluate the possible source of erroneous responses and provides corrective, remedial instruction.

Instructional games seek to impart knowledge under the auspices of entertainment (19:36-7). The most familiar games teach rudimentary skills (arithmetic, word association, and spelling). More sophisticated, higher level concepts can be taught such as wargame programs which teach military tactics. Another application of instructional games in computer-assisted instruction is their use in conjunction with other techniques to provide a motivational reward at the end of the training session for performance during the lesson. Oftentimes, the student is able to achieve superior performance in the game portion of the lesson using the knowledge gained during the learning portion of the lesson.

Modeling and simulation techniques are closely related and offer perhaps the greatest potential for industrial and military applications. They attempt to represent a system

or process in which the student can change values and observe the results of his actions (19:37). Modeling implies no attempt to create realism; simulation attempts realism through graphic display or hybrid forms of equipment (19:37). Hillelsohn, a noted courseware development manager, describes the advantages of modeling and simulation as follows:

...simulation offers the opportunity to actually practice a skill. The student can make wrong decisions and get appropriate feedback about the consequences without the dangers and costs associated with real equipment. Computer-based simulation also allows the process being studied to be stopped, started, reviewed, slowed down, speeded up, or altered to enhance understanding [12:42].

It is apparent that modeling and simulation are applicable to numerous industrial and military situations, especially in developing skills in manufacturing processes or casualty control procedures for which actual practice is expensive, dangerous, or rarely occurs naturally (12:42).

The final computer-assisted technique, problem solving, entails the use of the computer by the student to solve problems as a means of knowledge achievement (19:37).

Each of these modes of computer-assisted instruction could be used advantageously to augment aviation storekeeper training. The mode selected depends on the primary intent of the instruction. For instance, tutorial methods could be used to impart new knowledge of supply operations, drill and practice methods could be used to practice repetitive operations such as material identification, modeling and

simulation could be used to simulate actual supply operations. Since the intent of this research project was to develop a method of imparting new knowledge to aviation storekeepers, the tutorial mode of computer-assisted instruction was selected as the most effective means of achieving this goal.

Advantages and Disadvantages of Computer-Assisted Instruction

Before discussing the components of a computer-assisted instructional system, it is helpful to review the advantages and disadvantages of the use of computer-assisted instruction. In separate articles, Govaerts and Grillot (11:28-9), Walker (22:39+), and Bork (2), noted experts in the field of computer-based learning, individually discuss advantages and disadvantages of computer-assisted instruction. However, Dr. Margaret Bahniuk's list (1:85) is comprehensive and encompasses their thoughts. Dr. Bahniuk, Associate Professor of Business Education at Cleveland State University, includes the following advantages of computer-assisted instruction:

1. "The process is interactive; the student has an active role in the learning process.
2. The process is flexible and consistent. Each student learns at his own pace and studies only that material required to gain subject mastery.
3. The student gets instant feedback on performance during the training process.
4. A reduction in actual equipment needs by graphics capabilities allowing simulations.

5. A reduction in total time needed for training (as a result of prescribed learning evolutions).
6. A corresponding reduction in total training costs."

She also lists the following disadvantages:

1. "Time may be insufficient for implementing or revising software.
2. Limited computer equipment may lead to scheduling problems.
3. Software may be unreliable.
4. System response time (elapsed time between student computer input and computer response) may be inadequate.
5. Some people may learn best in other environments (classroom, self-study, or personal interaction)."

Of the above advantages, the reduction in training time and its associated cost savings is notable. "An average time saving of one-third is typically found in comparing computer-based education programs with conventional ones" (22:40).

Despite the seemingly overwhelming arguments for using computer-assisted instruction, Reynolds (19:38) and Walker (22:41) are careful to note that computer-assisted instruction cannot totally replace conventional training, but rather can supplement these techniques. Computer-assisted instruction should be used in those areas where it is the better training technique, but not attempted in those cases where it is clearly not as capable.

Another major drawback to computer-assisted instruction, as noted above, is the time and cost constraints of developing and maintaining/updating training

modules (22:42). Highly complex, multi-media training modules are very expensive (as much as \$50,000 to \$500,000) (14:136), but perhaps worth the expense, if the training is not available using conventional techniques or if an overall cost savings is realized from not training on actual equipment. However, the expense of developing tutorial modules should be minimal and more than offset the savings in training time for computer-assisted instruction to be beneficial.

Assuming that the manager decides to implement some form of computer-assisted instruction to augment his training program, the next step is selection of a system to present the material. The following section will describe the components of a computer-assisted instruction system and present some of the considerations for each of the components.

Computer-Assisted Instruction Systems

Figure 2.2 illustrates the three basic components of a computer-assisted instruction system - hardware, software, and courseware. Note that the final two components can be integrated or separate. Each of these components will be discussed in greater detail.

The hardware component is the computer itself and any peripherals required for data input, output, or storage. The computer may be a mainframe computer with interconnected terminals (centralized or timeshared system) or a

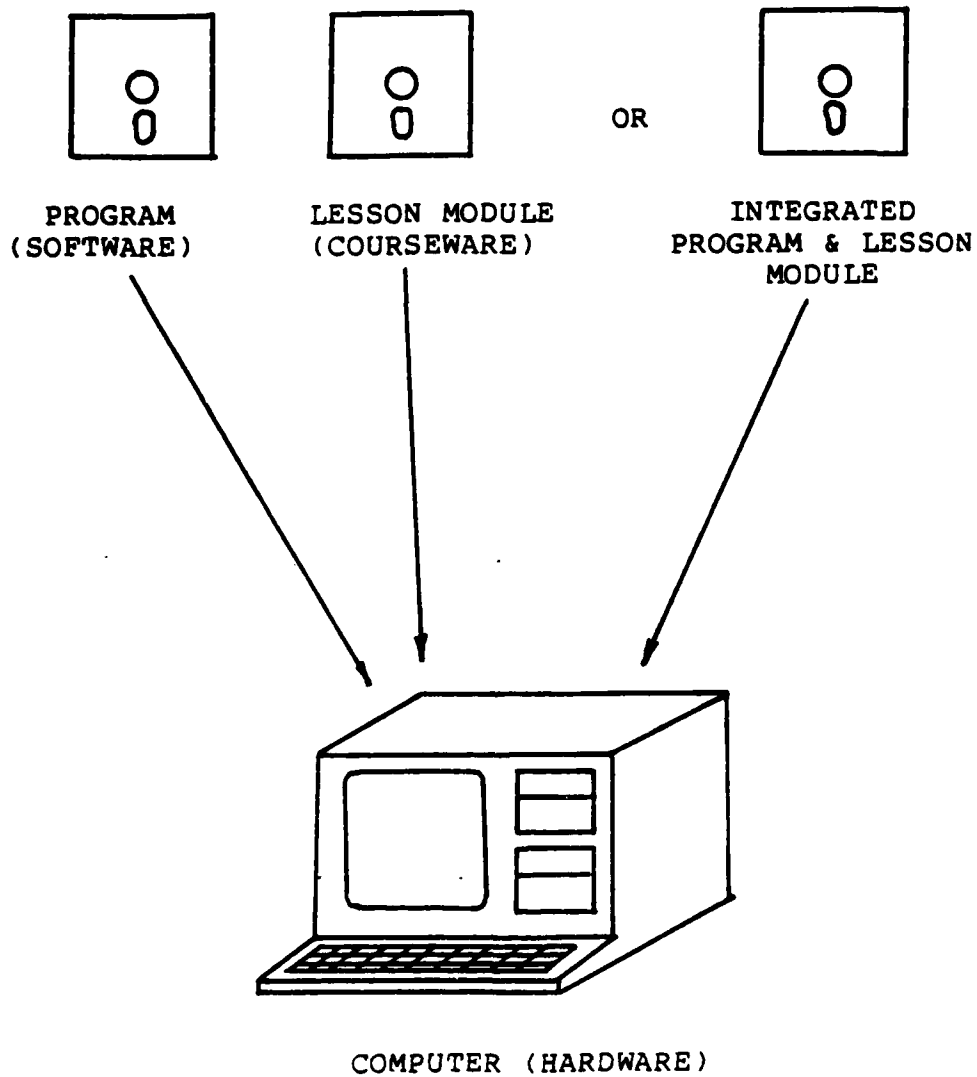

Figure 2.2: Computer-Assisted Instruction System Components

standalone microcomputer. The hardware chosen for a computer-assisted instruction system depends on the application or the extent of training to be conducted on the system. However, Reynolds and Davis argue against using existing mainframe computers for training purposes for two key reasons - controls over access to operations computers and limited computer power of these computers (20:45). Therefore, the standalone microcomputer was chosen as the hardware selection for this research project.

Software is the program which enables the computer to operate. For computer-assisted instruction purposes, software is the program which operates the computer to present the instructional material, branch to different portions of the material, and record information from the training period. Common programming languages for computer-assisted instruction systems include Pascal, BASIC, CP/M, C, and FORTH.

Courseware is the instructional material itself including text, questions, answers, and branching instructions. It can consist of formatted ASCII text files or can be incorporated in the software as is commonly found in simple BASIC language computer-assisted instruction systems. Courseware can be developed using common text editors (i.e., word processing programs) or written with the help of a courseware authoring program, as was done in this research project.

Of these three computer-assisted instruction system components, the most important from an effectiveness perspective is the courseware. Boyd and Eldridge (3:36+), Fauley (8:22+), and Hillelsohn (12:42+), noted experts in the field of computer-based education, each discuss the importance of quality courseware when implementing computer-assisted instruction techniques. Poorly written, boring, or incorrect instructional materials are more detrimental when used in conjunction with computers than in other mediums. Boyd and Eldridge in particular argue that courseware ergonomics (the relationship between learners and the computer; human factor considerations) would be of primary importance in computer-assisted instruction methods (3:38). They state, "It is unfortunate that many print aids have not been adapted in [computer-assisted instruction] ... learners need even more help when using an unfamiliar medium" (3:38). The print aids to which they refer include simple sentence structure, active voice, shorter sentences, shorter paragraphs, and adequate use of blank space (3:38).

To further enhance the effectiveness of computer-assisted instruction, Boyd and Eldridge maintain that the programs must be as user friendly as possible and that the trainee must understand how to use the program. The quality of the courseware is of little consequence if the trainee does not understand how to turn the computer on, load the training module, operate the keyboard, exit the program, and turn the computer off (3:38-9). For those people already

apprehensive of computers, lack of this requisite knowledge alone can doom the training program to fail.

For the purposes of this research project, the computer-assisted instruction system was somewhat predetermined. For reasons cited elsewhere, the hardware consisted of a standalone microcomputer system. The software consisted of a product of this research and was written in the BASIC computer language (note, though, that the program could have been compiled and run in assembly or machine language). The courseware was developed using another product of this research, a BASIC language courseware authoring program, to be used in conjunction with the software program.

III. Methodology

General Method

Two microcomputer programs were developed using the BASIC programming language. The first program, WRITE/BAS, functioned as a courseware development aid; the second, LEARNER/BAS, functioned as a courseware administration program. Documentation for each of the programs was then developed. Finally, instructions for using each of the programs were developed in the form of a user's guide.

Specific Procedures

The elements of this computer-assisted instruction system were developed on a Radio Shack, TRS-80, Model 4 microcomputer. This microcomputer is a Z-80 based high speed microprocessor with 64K of memory (18:A-47) and two 5.25 inch single-sided floppy disk drives. The microcomputer operates under the TRSDOS (Tandy Radio Shack Disk Operating System) Version 6 operating system (copyright 1983, Logical Systems).

Step 1. Since a specific microcomputer was available, the first step in developing this microcomputer program was the selection of a programming development language. Bruce Tonkin, a noted software developer and computer industry critic, compares BASIC, Pascal, and C using a 100 point scale in each of ten equally weighted categories (easy to learn, handles typical data types, ease of disk-file read/write, access to other languages, access to hardware or

disk operating system, capability of input/output to standard devices, includes or allow graphics, contains transcendental functions, has standard syntax, and capable of modularity support). His assessment of BASIC as being the superior of these three languages and its particular applicability to this programming project led to the selection of BASIC as the development language for this program (21:96+). The specific language used was BASIC for TRSDOS Version 6 (copyright 1983, Microsoft).

Step 2. The next step was the development of block diagrams for each of the programs. The block diagrams depict the program logic and serve as program development tools.

Step 3. The next step was the writing of the programs in BASIC code. A modular approach was used to facilitate program efficiency and modification. Program operation was fully documented using remarks within the code.

Step 4. The next step involved program testing and debugging. Since a modular programming approach was used, this task was eased considerably - each module could be tested and debugged individually. Several training modules were developed using the program, and test runs of the training program were conducted to demonstrate their proper functioning. One of the training modules developed serves as an introductory lesson which can be executed from the LEARNE BAS program.

Step 5. The next step entailed modifying the programs to operate on a different type of computer to demonstrate the programs' transportability. The program was manually modified to operate on a Z-248, IBM AT/PC compatible microcomputer under GW-BASIC. Each of the preceding steps were in support of the first research objective.

Step 6. The final step consisted of developing the written documentation and guidelines for using the programs to administer computer-assisted instruction. This step was in support of the second and third research objectives.

IV. System Development

The products of this research project are presented in Appendices A through F of this report. Appendix A contains the documentation and program listings for LEARNER/BAS, Appendix B illustrates operation of the program, and Appendix C contains the user's guide for this program. Appendix D contains the documentation and program listings for WRITE/BAS, Appendix E illustrates operation of the program, and Appendix F contains the user's guide for this program.

In addition to this report, computer disks containing the programs (individual disks for Tandy Model IV and IBM PC/AT compatible versions) and a separate user's guide for the system were produced. At the time this research report was submitted, a distribution scheme for disks and copies of the user's guide had not been developed. Parties interested in obtaining these products are encouraged to contact the author at the following address: LT Robert Mason, c/o C. L. Mason, 721 Sunburst Lane, Dallas, TX 75218.

The remainder of this chapter discusses development of these programs and the user's guide.

Program Development

As discussed in the preceding chapter, the development of this computer-assisted instruction system basically followed standard programming procedures (developing block/flow diagrams, encoding the programs, and testing/

debugging the programs). Although a total "top-down" approach is enviable, the author found the programs to be very dynamic from the beginning of development. As modules were written and tested, enhancements were identified and added to the program. The dynamic nature of this system will be discussed in greater detail in a later section of this report.

In essence, WRITE/BAS and LEARNER/BAS comprise a specialized data base management program with word processing features. Blocks of records form a lesson screen. During lesson execution, the student's computer input at the end of the screen determines the next block of records to be displayed. WRITE/BAS is a courseware development tool with limited word processing features for creating the data base which LEARNER/BAS will use to present the lesson to a student.

The program was envisioned as displaying formatted screens to the student/courseware author throughout the lesson. The top line of the screen provided information about the lesson while the bottom line of the screen provided instructions/prompts for using the program. Twenty lines between these lines contained the text material to be presented. Examples of this screen "boilerplate" are illustrated throughout Appendices B and E. The author felt that three general types of screens (i.e., text, multiple choice question, and true/false question) would allow lesson development and training potential.

The next step in development of this system was design of the data base holding the lesson text records. It was clear that lesson lengths would exceed the memory capacity of the Model IV and would therefore require storage on disk. Data records were accessed as necessary during lesson execution. Consideration then turned to whether records should be stored as a sequential ASCII file or as a formatted, direct-access file. Consideration of disk storage efficiency (amount of information that can be stored on a single disk) would favor a sequential file. However, direct-access files allow much quicker access to specific records within the file. Since a major advantage of computer-assisted instruction is selective branching within a lesson and since prolonged computer response times (i.e., elapsed time from student input to computer response) can be distracting to the learning process, a direct-access file was chosen as the format for storage of lesson material. The record file formats for this file are contained in Appendices A and D.

Early in the design process it was realized that searching through a lengthy direct-access file for a particular lesson page number would be highly inefficient and severely degrade computer response time. The text file is, therefore, read once and information from the header records extracted (record number, page number, and number of additional records forming the page) to form a lesson table on the disk in a sequential ASCII format. This table is

then read into the computer memory during lesson initialization. This procedure allows very rapid identification of the file records to read and display during lesson execution. Again, the elements of this file are contained in Appendices A and D.

The final disk file used by this system is a student file containing results of lesson execution. The student's name, date lesson executed, number of responses requested, number of correct and incorrect responses, and question numbers/incorrect responses are stored in memory and written to a disk file on lesson termination. This data is printed using a portion of the WRITE/BAS program. The elements of this file are contained in Appendices A and D and a sample of the resulting report is illustrated in Figure E.6. Although the student file report calculates and prints a percentage grade for the lesson, this grade is printed for use by courseware monitors primarily for lesson modules comprised totally of questions (i.e., tests). For instructional lesson modules, the grade and incorrect questions/responses reflect the quality of the courseware. For instance, a question missed repeatedly indicates a shortcoming in instruction or question construction.

Once data base requirements were established, the two programs were developed to create and use this data base structure. Program organization (a personal preference of the author) was such that subroutines are physically located at the beginning of the program with the main program

following. Both programs were documented throughout development with liberal remark lines.

LEARNER/BAS was first program of the two to be developed. It was developed on the Tandy Model IV microcomputer. Conversion of the program for operation on an IBM PC/AT compatible computer will be discussed later. Structure of this program and additional comments regarding program operation are documented in Appendix A of this report. WRITE/BAS was then developed and proved to be the more complicated program. Structure of this program and additional comments regarding program operation are documented in Appendix D of this report.

Since eventual conversion of the programs to IBM PC/AT compatible microcomputer operation was desired, several precautions were taken in program development. First, no PEEKS or POKES (i.e., manipulation of memory outside BASIC commands) were allowed. Second, no machine/assembly language subroutines were allowed. Third, disk drive designations were assigned in single line variable assignments rather than in each OPEN statement which would require fewer changes during conversion. These constraints did not prove to be a hinderance in program development.

Both programs were tested and debugged initially by the author. Improvements and enhancements were noted during testing and incorporated into the program code. The author attempted to "crash" the programs using both logical and illogical means and error routines/corrections developed

where necessary. During this phase of program development, a tendency to attempt protection against any eventuality was noted. It was necessary to balance the possibility of erroneous input against the additional coding required to provide protection. All reasonable errors have been protected in the current versions of the programs.

The programs were then extensively tested by an adult high school graduate and one teenager. Since neither had significant computer experience, these test cases represented typical skill levels of military and civilian DOD personnel. Each successfully used the programs with no direction from the author. Problem areas were observed and changes incorporated or noted for inclusion in the user's guide. The programs were then demonstrated to several AFIT graduate students for additional evaluation.

Program conversion was accomplished by uploading the BASIC programs in ASCII format to the Air Force Institute of Technology mainframe computer and then downloading them to the Zenith Z-248 microcomputer. This effectively converted the programs from a TRSDOS formatted disk to an MS-DOS formatted disk.

Conversion from this point was straightforward due to the similarities between the two versions of Microsoft BASIC used. However, four differences existed between the two versions which affected conversion of these programs. First, drive designations for the data files had to be changed (TRS-DOS version designates drives numerically after

the file name while MS-DOS designates drives alphabetically before the file name). Second, the method of locating the cursor on the screen required change. The Tandy version uses "PRINT@ (xx,yy)" (where xx is line position and yy is column position) to locate the cursor while the MS-DOS version required "LOCATE xx,yy" to position the cursor. Third, one non-standard ASCII character (ASCII value 31) required emulation in the MS-DOS version. In the TRSDOS version, ASCII value 31 erases the display to the end of the current line. This was emulated on the Zenith microcomputer by the commands "LOCATE xx,yy:PRINT STRING\$(81-POS(0),32): LOCATE XX,YY". These commands position the cursor, print blank characters to the end of the line, and then reposition the cursor to the original location. Fourth, the TRSDOS version begins numbering lines and columns with zero, while the MS-DOS version begins with one.

Following conversion, the program was tested on the Zenith Z-248 microcomputer using the same procedures as described earlier. No changes were required with the exception of the above mentioned differences in BASIC versions.

Documentation Development

Following program development, debugging, and testing, documentation for the programs was generated. This program documentation is included in Appendices A and D of this report. Included are program overviews; block diagrams

of program operations; variable lists; cross-reference listings by line number, variable name, and BASIC keywords; and the program listings. This complete program documentation is provided for those who may wish to modify or enhance the programs.

User's Guide Development

The final step in the development of this computer-assisted instruction system was the writing of the user's guide to provide instructions regarding use of the system. The results of this effort are contained in Appendices C and F of this report. The information in these appendices was also combined into a single, separate document The WRITE-LEARNER Computer-Assisted Instruction System User's Guide. As mentioned previously, a distribution plan for this document had not been developed as of submission of this report.

V. Recommendations

As with many programming endeavors, one of the most difficult decisions of this research project was knowing when to stop. Any computer program can be improved and enhanced virtually without end. Therefore, this programming endeavor stopped when the author was satisfied with the results and would be willing to use the system. The program can be used as it stands or can be improved to the user's content.

In retrospect, many changes would have been made by the author had time permitted. However, these changes will have to wait for future versions of the program. It is the sincerest desire of this researcher that the program grow and expand as users improve and change the program. Nevertheless, recommendations and recommendations for further study are provided.

Recommendations

Recommendation Number One. Recommend that the Air Force Institute of Technology (AFIT) investigate the use of this computer-assisted instruction system for use in exportable education. Current policies include sending field training teams to Air Force bases for training. Many courses could be developed and taught using this computer-assisted instruction system, thereby saving the expense of sending training teams to remote locations.

Recommendation Number Two. Recommend that components of the Department of Defense make this computer-assisted instruction system available to operating components for use. Recommend further that these agencies become repositories for enhancements and improvements to the programs as provided by using activities.

Recommendations for Further Research

Recommendation Number One. Extensive field testing of the final product of this research project was not possible. This testing, comparing the relative effectiveness of this computer-assisted instruction system to other training methods (classroom, programmed instruction, self-study), could be performed.

Recommendation Number Two. Many enhancements and improvements to this computer-assisted instruction system are possible as a research project. Improvements to the editor portion of WRITE/BAS are possible. Computer graphic capabilities could be added.

Recommendation Number Three. The potential exists for linking this computer-assisted instruction system to multimedia presentations (video disk, photographic slides, and simulation equipment), especially using the TARGA 16 AT&T system.

Recommendation Number Four. The programs could be converted to operate on different microcomputers or converted to operate on a timesharing, mainframe computer.

Appendix A: LEARNER/BAS Program Documentation

Contents

	Page
LEARNER/BAS Program Overview.	A- 2
LEARNER/BAS Variable List	A- 6
LEARNER/BAS Record File Formats	A- 8
LEARNER/BAS BASIC Variables Cross-Reference List. . .	A-13
LEARNER/BAS Line Number Cross-Reference List.	A-16
LEARNER/BAS BASIC Keywords Cross-Reference List . . .	A-17
LEARNER/BAS Program Listing (TRSDOS Version).	A-20
LEARNER/BAS Program Listing (MSDOS Version)	A-29

LEARNER/BAS Program Overview

LEARNER/BAS is a program written in the BASIC programming language which is one component of the WRITE-LEARNER computer-assisted instruction system. The system was developed on a Tandy/Radio Shack Model IV microcomputer and subsequently converted and tested on a Zenith Z-248 (IBM PC/AT compatible) microcomputer. LEARNER/BAS administers interactive, computer-assisted instruction courseware modules developed using the WRITE/BAS program.

This appendix contains the documentation for the LEARNER/BAS program. Included are comments about program operation; block diagrams to illustrate the program logic; a description of the variables used in the program; cross-reference listings by variable name, line number, and BASIC keywords; and the program listings (TRSDOS and MSDOS versions). A user's guide for the program is included as a separate appendix.

LEARNER/BAS is essentially a specialized data-base manager. Lesson courseware is stored in formatted, direct-access, disk records which are read as required during lesson execution. A header record contains certain data about a lesson page (page type, page number, and jump pages). Following the header record are from 1 to 20 text records which comprise the lesson page. A second file, a sequential ASCII lesson table file, is generated from the lesson text file and is read into memory during lesson

execution to allow improved response times in locating records in the text file. A third file, a sequential ASCII student file, is generated during lesson execution and stores student data (student name, date lesson executed, and total/correct/incorrect question responses) about the lesson use. Refer to the LEARNER/BAS Record File Formats for a description of these files.

Figure A.1 is a simplified block diagram illustrating the operation of LEARNER/BAS. Line numbers refer to both versions of the program (TRSDOS and MSDOS) since line number consistency was maintained during program conversion.

If attempting to compile this program or convert it to operate on another type of computer, several cautions are in order. First, the program uses REMARK line numbers in program flow. GOTO and GOSUB commands must be changed to reflect deletions of REMARK statements. Second, the MSDOS version of LEARNER/BAS emulates certain functions of the TRSDOS version (PRINT CHR\$(30) in TRSDOS BASIC erases display to end of current line which was emulated in MSDOS BASIC by LOCATE xx,,yy:PRINT STRING\$(81-POS()),32):LOCATE xx,yy). Since the TRSDOS version of this program was the original version written, any conversion should begin with that program listing and the cross-reference listings included in this appendix.

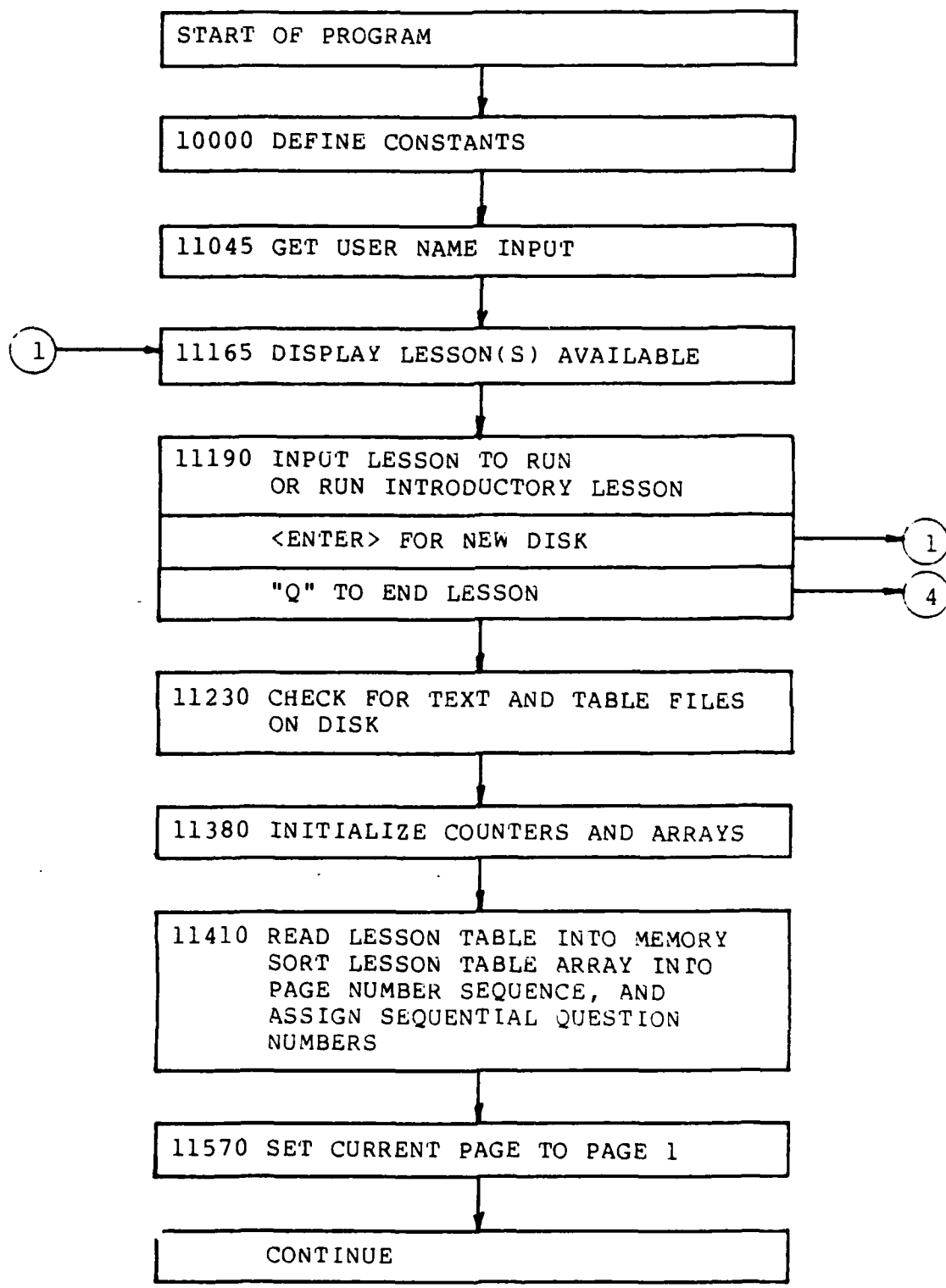

NOTE: → (n) indicates branch to corresponding (n) → .

Figure A.1: LEARNER/BAS Block Diagram

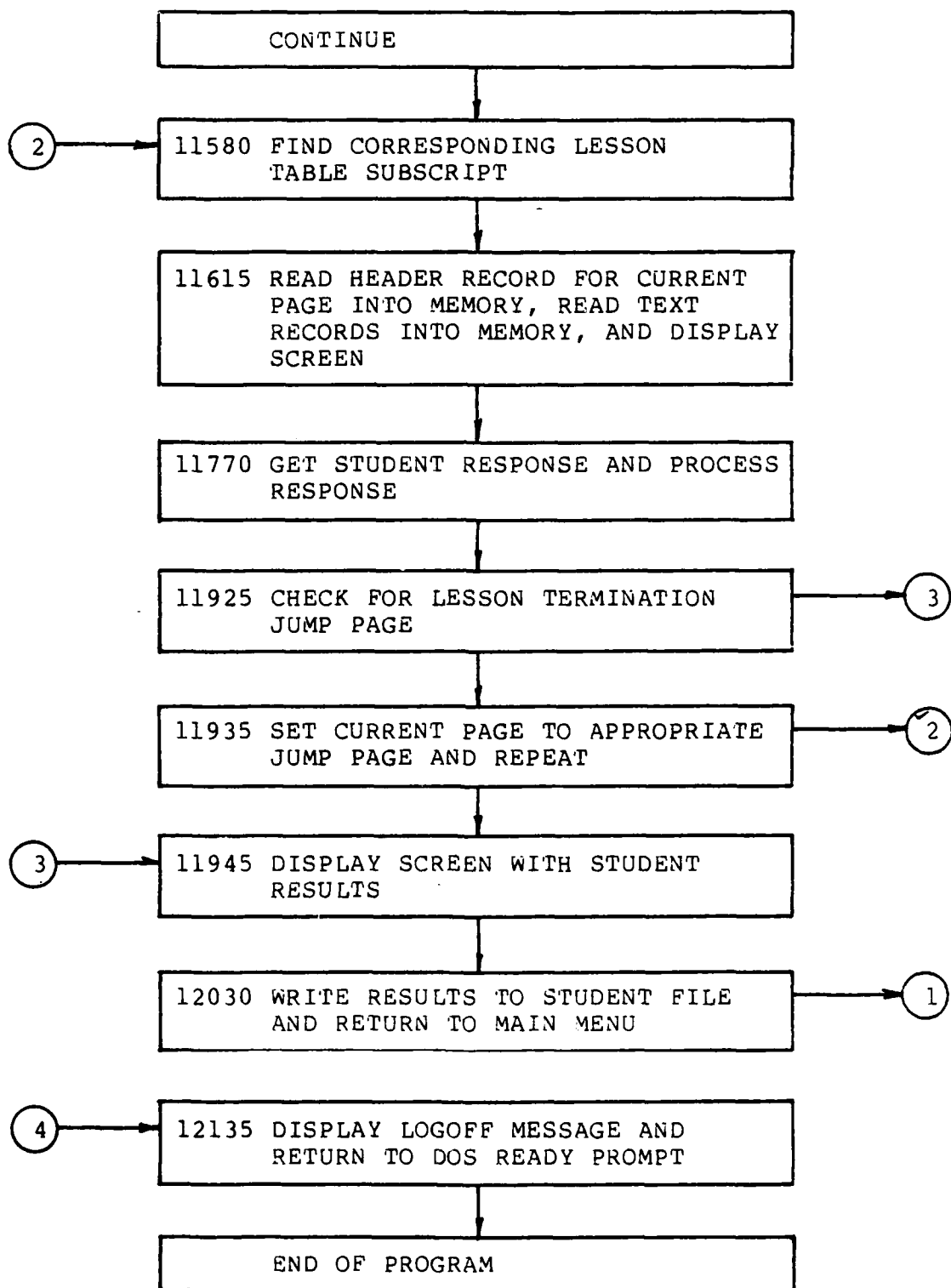

Figure A.1: LEARNER/BAS Block Diagram (continued)

LEARNER/BAS Variable List

A\$	String for user input from keyboard.
AJUMP%	Go to lesson page number for <A>/<T>/<ENTER> response.
ANSWER\$	Correct answer for question (A-E or T/F).
BJUMP%	Go to lesson page number for /<F> response.
BUFi\$	Temporary buffer variable for use with direct access files (i=integer value).
CJUMP%	Go to lesson page number for <C> response.
COUNT%	Counter for finding array subscript in lesson table.
DASH\$	String of 80 dash characters.
DJUMP%	Go to lesson page number for <D> response.
DUMMY\$	Dummy variable for reading unused portions of direct access files.
EJUMP%	Go to lesson page number for <E> response.
ENTER\$	"Press <ENTER>..." instruction line.
FLAG%	Flag variable returned from subroutines to identify specific disk errors.
GRADE%	Student's grade for lesson answers (100 point scale).
I	FOR/NEXT loop counter.
MORE%	Number of associated disk records required to generate lesson page in lesson text file.
MORE%(Number of associated disk records required to generate lesson page in lesson table array.
NUMPAGES%	Number of pages in lesson text file.
PAGE%(Lesson page number in lesson table array.
PAGE%	Lesson page number in lesson text file.
PROMPT\$	"Press <letter> of your choice..." instruction line.
QDATA\$	"Enter requested data and press <ENTER>..." instruction line.
QINST\$	Instruction line to be displayed on lesson screen page.
QMAT%	Array subscript in lesson table.
QNAME\$	Lesson name to be displayed on lesson screen page.
QNUM%(Question number in lesson table.

QNUM%	Temporary counter for assigning question numbers in lesson table.
QPAGES\$	Page number to be displayed on lesson screen page.
QPAGE%	Lesson page number being displayed in lesson execution/active page number.
QTEST\$	File name for determining if file is on disk.
QUEST\$	Question number to be displayed on lesson screen page.
RANSWER\$	"Right response! Press <ENTER>..." instruction line.
RCOUNT%	Number of correct responses to questions asked.
START%(Starting lesson text file record number in lesson table.
START%	Starting lesson text file record number in lesson table file.
STUDENT\$	Student's name (first initial and last name, no space).
STUFILES\$	Name of file for writing student lesson data.
TABLE\$	File name of lesson table disk file.
TCOUNT%	Total number of questions asked.
TEST%	Temporary variable for testing capital character input during student name input.
TEXT\$(Temporary array holding text lines of lesson pages.
TEXT\$	Disk file name for lesson text file.
TNAME\$	Name of lesson to run.
TYPE\$	Lesson page type indicator (#=text page; ?=question page).
TYPE\$(Lesson page type indicator in lesson table.
WANSWER\$	"Wrong response! Press <ENTER>..." instruction line.
WCOUNT%	Number of incorrect responses to questions asked.
WQUEST\$(Array holding incorrect responses to questions asked.
WQUEST%(Array holding question numbers to which student responded incorrectly.
YNINST\$	"Press <Y>es or <N>o to continue..." instruction line.

LEARNER/BAS Record File Formats

LEARNER/BAS uses three files produced by the WRITE/BAS program and produces one file for use by the WRITE/BAS program. The following pages contain the record file formats for these files. Although sequential ASCII files are not formatted (data elements are variable length), lengths are provided for these data elements for reference purposes.

The first file used by LEARNER/BAS, <Lesson Name>/TXT is comprised of two different types of formatted, direct-access records which form a page "block". A header record containing information about the lesson page is followed by from 1 to 20 text records which contain the page text material.

The second file, <Lesson Name>/TAB, is a sequential ASCII file which contains certain information from the text header records. This file is loaded into memory permitting very rapid access of the proper text records.

The third file, <Lesson Name>/STU, is a sequential ASCII file which contains data generated during lesson use. This file is appended on completion of each execution of a lesson module. If the file does not exist, then it is created by the LEARNER/BAS program.

File: <Lesson Name>/TXT (Header records)
 Type: Formatted, direct access

<u>Length</u>	<u>Variable/s</u>	<u>Type</u>	<u>Remarks</u>
1	TYPE\$ BUF1\$	A	Page type; # = text page, ? = question page, null/blank = text record, * = deleted record.
5	PAGE% BUF2\$	N	User defined page number; used for lesson branching/reference purposes.
5	AJUMP% BUF3\$	N	Branch to page for <A> response to multiple choice question, <T> response to true/false question, or <ENTER> key for text page.
5	BJUMP% BUF4\$	N	Branch to page for response to multiple choice question or <F> response to true/false question.
5	CJUMP% BUF5\$	N	Branch to page for <C> response to multiple choice question.
5	DJUMP% BUF6\$	N	Branch to page for <D> response to multiple choice question.
5	EJUMP% BUF7\$	N	Branch to page for <E> response to multiple choice question.
1	ANSWER\$ BUF8\$	A	Correct response for question; must equal A-E or T/F.
3	MORE% BUF9\$	N	Number of additional records of page (i.e., number of text lines); must equal 1-20 (third character reserved by BASIC for sign).
46	DUMMY\$		Not used in header records.

Total record length = 81

File: <Lesson Name>/TXT (text records)
Type: Formatted, direct access

<u>Length</u>	<u>Variable/s</u>	<u>Type</u>	<u>Remarks</u>
1	-	A	Null/blank=text record; *=deleted record.
80	TEXT\$	A/N	Text line.

Total record length = 81

File: <Lesson Name>/TAB
Type: Sequential ASCII

<u>Length</u>	<u>Variable/s</u>	<u>Type</u>	<u>Remarks</u>
5	PAGE% BUF2\$	N	User defined page number; used for lesson branching.
4	START%	N	Starting file record number for PAGE% header record in <Lesson Name>/TXT file.
4	MORE%	N	Number of text records in <Lesson Name>/TXT file comprising PAGE%.
1	TYPE\$	A	Page type.

File: <Lesson Name>/STU
Type: Sequential ASCII

<u>Length</u>	<u>Variable/s</u>	<u>Type</u>	<u>Remarks</u>
NA	STUDENT\$	A	Student name (first initial and last name; no space).
NA	DATE\$	A/N	Variable length; format as returned by applicable BASIC/DOS.
4	TCOUNT%	N	Total questions asked during lesson (may differ from total questions in a lesson due to branching and/or repeated questions).
4	RCOUNT%	N	Number of correct responses.
4	WCOUNT%	N	Number of incorrect responses.
4	WQUEST%(i)	N	Question number answered incorrectly (i=1 to WCOUNT%).
1	WQUEST\$(i)	A	Incorrect response to question (i=1 to WCOUNT%).

LEARNER/BAS BASIC Variables Cross-Reference List

A\$	215	220	225	245	250	255	275
	280	285	305	310	315	355	11145
	11830	11835	11840	11845	11850	11855	11860
	11890	11895	11900	11905	12240	12240	
AJUMP%	11630	11805	11830	11890			
ANSWERS\$	11655	11780	11785	11855	11860	11900	11905
BJUMP%	11635	11835	11895				
BUF	11560	11560	11560	11560	11560	11560	11560
	11560	11560	11565	11565	11625	11630	11635
	11640	11645	11650	11655	11660	11685	11690
CJUMP%	11640	11840					
COUNT%	11585	11590	11595	11595	11605		
DASH\$	130	135	10020				
DJUMP%	11645	11845					
DUMMY\$	11560	11685					
EJUMP%	11650	11850					
ENTERS\$	10025	11250	11330	11710	11950		
FLAG%	155	175	180	185	190	11245	11255
	11325	12080	12085				
GRADE%	11955	12015					
I	11430	11440	11440	11440	11440	11445	11445
	11460	11470	11475	11480	11485	11490	11495
	11500	11510	11520	11525	11530	11540	11675
	11680	11690	11695	11745	11750	11755	12095
	12100	12100	12105	12180	12180	12210	12210
	12210	12210					
J	11475	11480	11485	11490	11495	11500	11505
MORE%	11390	11660	11675	11745			
MORE%(11030	11400	11440	11495	11495		
NUMPAGES%	11460	11470	11475	11520			

PAGE%(11030	11400	11440	11480	11480	11485	11485
	11590						
PAGE%	11390						
PROMPT\$	10030	11715					
QDATA\$	10040	11050	11170				
QINST\$	135	11050	11120	11170	11250	11330	11415
	11710	11715	11950	12040	12145		
QMAT%	350	11605	11620	11680	11735		
QNAME\$	130	11050	11120	11170	11250	11330	11415
	11725	11950	12040	12145			
QNUM%(350	11035	11405	11530	11735		
QNUM%	11395	11515	11530	11535	11535		
QPAGES\$	130	11050	11120	11170	11250	11330	11415
	11720	11950	12040	12145			
QPAGE%	11570	11590	11720	11805	11830	11835	11840
	11845	11850	11890	11895	11930		
QTEST\$	165	11240	11320	12070			
QUEST\$	135	11170	11735	11735	11950	12040	12145
RANSWERS\$	375	10045					
RCOUNT%	385	385	11385	11955	11985	12090	
STAR\$	12200	12210	12210				
START%(11030	11400	11440	11490	11490	11620	11680
START%	11390						
STUDENT\$	11075	11090	12090				
STUFILES\$	12065	12070	12080	12085			
TABLE\$	11220	11320	11425				
TCOUNT%	11385	11730	11730	11955	11965	12090	
TEST%	11090	11095	11095				
TEXT\$(11035	11405	11690	11750			

TEXT\$							
	11215	11240	11395	11555			
TNAME\$							
	11150	11190	11195	11200	11205	11210	11210
	11210	11215	11220	11260	11275	11415	11725
	11950	12035	12065				
TYPE\$							
	11390	11625	11710	11715	11730	11735	11775
TYPE\$(
	11030	11400	11440	11500	11500	11525	
WANSWER\$							
	335	10050					
WCOUNT%							
	345	345	350	355	11385	11995	12090
	12095						
WQUEST\$(
	355	11035	11405	12100			
WQUEST\$							
	11395						
WQUEST%(
	350	11035	11405	12100			
WQUEST%							
	11395						
YNINST\$							
	10035	11120					

LEARNER/BAS Line Number Cross-Reference List

125 =>	11050	11120	11170	11250	11330	11415	11740
	11950	12040	12145				
150 =>	11240	11320	12075				
175 =>	160						
195 =>	175	180	185				
200 =>	170	195					
210 =>	11140						
215 =>	225						
240 =>	11825						
245 =>	255						
270 =>	11885						
275 =>	285						
300 =>	11295	11365	11800	11865	11910	12020	
305 =>	315						
330 =>	11855	11900					
370 =>	11860	11905					
10000 =>	10						
11045 =>	12245						
11070 =>	11105						
11115 =>	11095						
11165 =>	11145	11195	11300	11370	12035	12125	
11215 =>	11155	11205					
11260 =>	11255						
11265 =>	11255						
11275 =>	11255						
11280 =>	11255						
11290 =>	11260	11270	11275	11285			
11310 =>	11245						
11380 =>	11325						
11435 =>	11450						
11455 =>	11435						
11485 =>	11480						
11505 =>	11480						
11540 =>	11525						
11580 =>	11935						
11590 =>	11600						
11605 =>	11590						
11795 =>	11775						
11820 =>	11780						
11880 =>	11785						
11925 =>	11810	11870	11915				
11945 =>	11930						
12145 =>	220	250	280	310	11200		
12195 =>	200	11025					
12240 =>	12240						

LEARNER/BAS BASIC Keywords Cross-Reference List

*	11955						
+	345	385	10025	10030	10035	10040	10045
	10045	10050	10050	11215	11220	11415	11445
	11475	11535	11595	11680	11730	11735	12040
	12065	12200					
-	11210	11460	11470	11955			
<	315	11095	11525	11780	11785	11855	11900
	12240						
=	155	175	175	180	180	185	185
	190	215	220	225	245	250	255
	275	280	285	305	310	345	350
	355	385	10020	10025	10030	10035	10040
	10045	10050	11050	11050	11050	11090	11095
	11095	11120	11120	11120	11145	11150	11170
	11170	11170	11170	11195	11200	11205	11210
	11215	11220	11240	11245	11250	11250	11250
	11320	11325	11330	11330	11330	11385	11385
	11385	11415	11415	11415	11430	11445	11460
	11470	11475	11515	11520	11530	11535	11570
	11585	11590	11595	11605	11625	11630	11635
	11640	11645	11650	11655	11660	11675	11685
	11690	11710	11710	11715	11715	11720	11725
	11730	11730	11735	11735	11735	11745	11775
	11805	11830	11830	11835	11835	11840	11840
	11845	11845	11850	11850	11860	11890	11890
	11895	11895	11905	11930	11950	11950	11950
	11950	11955	12035	12040	12040	12040	12040
	12065	12070	12080	12085	12095	12145	12145
	12145	12145	12180	12200	12210	12240	
>	315	11095	11480	11525	11780	11785	11855
	11900	12240					
AND	11095						
ASC	11090						
CHR\$	220	250	280	310	315	12240	
CLOSE	200	11455	12035	12110	12140	12185	12245
CLS	130	12205					
DATE\$	12090						
DIM	11030	11035	11400	11405			
ELSE	11480	11735					
END	12185	12250					
EOF	11435						
ERASE	11390	11395					
ERL	12220						
ERR	175	180	185	12220			
ERROR	160	200	11025				
FIELD	11560	11565					
FOR	11470	11475	11520	11675	11745	12095	12180
	12210						
GET	11620	11680					
GOSUB	11050	11120	11140	11170	11240	11250	11295
	11320	11330	11365	11415	11740	11800	11825

GOSUB	11855	11860	11865	11885	11900	11905	11910
	11950	12020	12040	12075	12145		
GOTO	10	160	170	175	180	185	200
	11025	11105	11155	11255	11260	11270	11275
	11285	11300	11370	11450	11600	11810	11870
	11915	11935	12125				
IF	175	180	185	220	225	250	255
	280	285	310	315	11095	11145	11195
	11200	11205	11245	11325	11435	11480	11525
	11590	11710	11715	11730	11735	11775	11780
	11785	11830	11835	11840	11845	11850	11855
	11860	11890	11895	11900	11905	11930	12035
	12080	12085	12240				
INKEY\$	12240						
INPUT	215	245	275	305	11075	11190	11440
INSTR	225	255	285	11205	11210	11780	11785
LEFT\$	11090	11210					
NEXT	11505	11510	11540	11695	11755	12105	12180
	12210						
ON	160	200	11025	11255			
OPEN	165	11425	11555	12080	12085		
OPTION	11025						
PRINT	130	130	130	135	135	135	135
	335	340	375	380	11055	11060	11065
	11070	11100	11100	11100	11125	11130	11135
	11175	11180	11260	11265	11270	11275	11280
	11285	11290	11335	11340	11345	11345	11350
	11355	11355	11360	11420	11750	11760	11960
	11965	11970	11975	11980	11985	11990	11995
	12000	12005	12010	12015	12015	12045	12150
	12155	12160	12165	12170	12175	12210	12210
	12210	12210	12215	12220	12225	12230	12235
REM	1	2	3	4	5	6	7
	8	9	10	15	100	105	110
	115	120	125	145	150	175	180
	185	190	205	210	235	240	265
	270	295	300	325	330	365	370
	395	10000	10005	10010	10015	10055	11000
	11005	11010	11015	11020	11040	11045	11080
	11085	11110	11115	11150	11160	11165	11195
	11225	11230	11235	11305	11310	11315	11375
	11380	11410	11465	11545	11550	11570	11575
	11580	11610	11615	11665	11670	11700	11705
	11765	11770	11775	11780	11785	11790	11795
	11815	11820	11875	11880	11920	11925	11935
	11940	11945	12025	12030	12050	12055	12060
	12115	12120	12130	12135	12180	12190	12195
RESUME	195	12245					
RETURN	140	200	230	260	290	320	360
	390						
SOUND	340						
STR\$	11720	11735					

STRINGS	10020	10025	10030	10035	10040	10045	10050
	11415	12040	12200	12200			
SWAP	11485	11490	11495	11500			
SYSTEM	11185	12185					
THEN	175	180	185	220	225	250	255
	280	285	310	315	11095	11145	11195
	11200	11205	11245	11325	11435	11480	11525
	11590	11710	11715	11730	11735	11775	11780
	11785	11830	11835	11840	11845	11850	11855
	11860	11890	11895	11900	11905	11930	12035
	12080	12085	12240				
TO	11470	11475	11520	11675	11745	12095	12180
	12210						
USING	11965	11985	11995	12015			
VAL	11630	11635	11640	11645	11650	11660	
WRITE	12090	12100					

LEARNER/BAS Program Listing (TRSDOS Version)

```
1 *****
2 '* LEARNER/BAS - COMPUTER-ASSISTED INSTRUCTION SOFTWARE *
3 '* ROBERT MASON, LT, SC, USN *
4 '* AIR FORCE INSTITUTE OF TECHNOLOGY *
5 '* SCHOOL OF SYSTEMS AND LOGISTICS *
6 '* MAY 1987 *
7 '* TANDY/RADIO SHACK MODEL IV VERSION 01.00.00. *
8 *****
9 '
10 GOTO 10000 'JUMP TO START OF MAIN PROGRAM
15 '
100 *****
105 '* SUBROUTINES *
110 '* (LINES 100-9999) *
115 *****
120 '
125 ' SUBROUTINE - PRINT SCREEN BOILERPLATE
130 CLS
        :PRINT@(0,0),QNAME$;
        :PRINT@(0,76),QPAGES;
        :PRINT@(1,0),DASH$;
135 PRINT@(22,0),DASH$;
        :PRINT@(23,0),QINST$;
        :PRINT@(0,31),QUEST$ ;
        :PRINT@(2,0),;
140 RETURN
145 '
150 ' SUBROUTINE - CHECK FOR FILENAME ON DISK
155 FLAG%=0
160 ON ERROR GOTO 175
165 OPEN "I",1,QTEST$
170 GOTO 200
175 IF ERR=53 THEN FLAG%=1
        :GOTO 195 ' FILE NOT FOUND ERROR
180 IF ERR=57 THEN FLAG%=2
        :GOTO 195 ' DEVICE I/O ERROR
185 IF ERR=64 THEN FLAG%=3
        :GOTO 195 ' BAD FILE NAME ERROR
190 FLAG%=4 ' UNKNOWN ERROR
195 RESUME 200
200 CLOSE
        :ON ERROR GOTO 12195
        :RETURN
205 '
210 ' SUBROUTINE - WAIT FOR Y/N INPUT
215 A$=INPUT$(1)
220 IF A$=CHR$(5) THEN 12145
225 IF INSTR("YN",A$)=0 THEN 215
230 RETURN
235 '

```

```

240 '   SUBROUTINE - WAIT FOR A/B/C/D/E INPUT
245 A$=INPUT$(1)
250 IF A$=CHR$(5) THEN 12145
255 IF INSTR("ABCDE",A$)=0 THEN 245
260 RETURN
265 '
270 '   SUBROUTINE - WAIT FOR T/F INPUT
275 A$=INPUT$(1)
280 IF A$=CHR$(5) THEN 12145
285 IF INSTR("TF",A$)=0 THEN 275
290 RETURN
295 '
300 '   SUBROUTINE - WAIT FOR <ENTER> INPUT
305 A$=INPUT$(1)
310 IF A$=CHR$(5) THEN 12145
315 IF A$<>CHR$(13) THEN 305
320 RETURN
325 '
330 '   SUBROUTINE - HANDLE INCORRECT RESPONSE
335 PRINT@(23,1),WANSWER$;
340 PRINT@(23,0),;:SOUND 5,1
345 WCOUNT%=WCOUNT%+1
350 WQUEST%(WCOUNT%)=QNUM%(QMAT%)
355 WQUEST$(WCOUNT%)=A$
360 RETURN
365 '
370 '   SUBROUTINE - HANDLE CORRECT RESPONSE
375 PRINT@(23,1),RANSWER$;
380 PRINT@(23,0),;
385 RCOUNT%=RCOUNT%+1
390 RETURN
395 '
10000 '*****
10005 '*   CONSTANT TABLE AND DEFINED FUNCTIONS   *
10010 '*           (LINES 10000-10999)           *
10015 '*****
10020 DASH$=STRING$(80,45)
10025 ENTER$=STRING$(22,32)+"Press <ENTER> to continue."
10030 PROMPT$=STRING$(22,32)+"Press <letter> of your choice.
"
10035 YNINST$=STRING$(23,32)+"Press <Y>es or <N>o to continu
e."
10040 QDATA$=STRING$(14,32)+"Enter requested data and press
<ENTER> to continue."
10045 RANSWER$="Right response!"+STRING$(10,32)+"Press <ENTE
R> to continue."
10050 WANSWER$="Wrong response!"+STRING$(10,32)+"Press <ENTE
R> to continue."
10055 '
11000 '*****
11005 '*           MAIN PROGRAM           *
11010 '*           (LINES 11000-39999)           *
11015 '*****

```

```

11020 '
11025 OPTION BASE 1
      :ON ERROR GOTO 12195
11030 DIM PAGE%(200),START%(200),MORE%(200),TYPE$(200)
11035 DIM TEXT$(20),WQUEST%(200),WQUEST$(200),QNUM%(200)
11040 '
11045 '   PRINT SCREEN AND GET USER NAME
11050 QNAME$="MAIN MENU"
      :QINST$=QDATA$
      :QPAGE$=""
      :GOSUB 125
11055 PRINT"ENSURE THAT THE CAPS LOCK KEY IS DEPRESSED AND R
      EMAINS"
11060 PRINT"DEPRESSED FOR THE DURATION OF THIS LESSON!"
11065 PRINT
11070 PRINT"Input your first initial and last name in capita
      l letters with"
11075 INPUT"no space (example: RSMITH): ",STUDENT$
11080 '
11085 '   CHECK FOR CAPITAL INPUT - REPEAT IF NECESSARY
11090 TEST%=ASC(LEFT$(STUDENT$,1))
11095 IF TEST%>=65 AND TEST%<=90 THEN 11115
11100 PRINT
      :PRINT"Erroneous input...ensure that the caps lock
      key is depressed!"
      :PRINT
11105 GOTO 11070
11110 '
11115 '   OFFER TO RUN INTRODUCTORY LESSON
11120 QNAME$="MAIN MENU"
      :QINST$=YNINST$
      :QPAGE$=""
      :GOSUB 125
11125 PRINT@(2,0),"Do you want to run a short introductory l
      esson about this"
11130 PRINT"computer-assisted instruction program before sta
      rting a lesson?"
11135 PRINT@(23,0),;
11140 GOSUB 210
11145 IF A$="N" THEN 11165
11150 TNAME$="INTRO"      '   RUN INTRO LESSON
11155 GOTO 11215
11160 '
11165 '   PRINT SCREEN, LESSON CATALOGUE, AND GET LESSON
      FILE NAME
11170 QNAME$="MAIN MENU"
      :QINST$=QDATA$
      :QPAGE$=""
      :QUEST$=""
      :GOSUB 125
11175 PRINT@(2,0),"The following lesson files are available
      on this disk:"
11180 PRINT

```

```

11185 SYSTEM "DIR $/TXT:1 (ALL=OFF)"
11190 INPUT"Enter lesson to run or change data disk and pres
s <ENTER>: ",TNAME$
11195 IF TNAME$="" THEN 11165 'NEW DISK CATALOG
11200 IF TNAME$="Q" THEN 12145
11205 IF INSTR(TNAME$,"/")=0 THEN 11215
11210 TNAME$=LEFT$(TNAME$,(INSTR(TNAME$,"/")-1))
11215 TEXT$=TNAME$+"/TXT"
11220 TABLE$=TNAME$+"/TAB"
11225 '
11230 ' CHECK FOR LESSON TEXT FILE ON DISK, PRINT ERROR
MESSAGE, AND
11235 ' RETURN TO MAIN MENU IF NECESSARY
11240 QTEST$=TEXT$
:GOSUB 150
11245 IF FLAG%=0 THEN 11310
11250 QNAME$="ERROR"
:QINST$=ENTER$
:QPAGE$=""
:GOSUB 125
11255 ON FLAG% GOTO 11260,11265,11275,11280
11260 PRINT TNAME$;" is not on these disks."
:GOTO 11290
11265 PRINT"A device input/output error has occurred!"
11270 PRINT"Terminate this session and contact your training
supervisor."
:GOTO 11290
11275 PRINT TNAME$;" is not a valid lesson name."
:GOTO 11290
11280 PRINT"An unknown disk error has occurred!"
11285 PRINT"Terminate this session and contact your training
supervisor."
:GOTO 11290
11290 PRINT@(23,0),;
11295 GOSUB 300
11300 GOTO 11165
11305 '
11310 ' CHECK FOR LESSON TABLE FILE ON DISK, PRINT ERROR
MESSAGE, AND
11315 ' RETURN TO MAIN MENU IF REQUIRED
11320 QTEST$=TABLE$:GOSUB 150
11325 IF FLAG%=0 THEN 11380
11330 QNAME$="ERROR"
:QINST$=ENTER$
:QPAGE$=""
:GOSUB 125
11335 PRINT"Unable to run this lesson...the corresponding le
sson table"
11340 PRINT"file is not on these disks."
11345 PRINT
:PRINT"Contact your training supervisor to make co
rrections to"
11350 PRINT"this lesson disk."

```

```

11355 PRINT
      :PRINT"You may try another lesson or terminate thi
      s session."
11360 PRINT@(23,0),;
11365 GOSUB 300
11370 GOTO 11165
11375 '
11380 '   INITIALIZE QUESTION COUNTERS AND ARRAYS
11385 TCOUNT%=0
      :RCOUNT%=0
      :WCOUNT%=0
11390 ERASE PAGE%,START%,MORE%,TYPE$
11395 ERASE TEXT$,WQUEST%,WQUEST$,QNUM%
11400 DIM PAGE%(200),START%(200),MORE%(200),TYPE$(200)
11405 DIM TEXT$(20),WQUEST%(200),WQUEST$(200),QNUM%(200)
11410 '   READ LESSON TABLE
11415 QNAME$=TNAME$
      :QINST$=STRING$(20,32)+"Loading lesson table...ple
      ase wait..."
      :QPAGE$=""
      :GOSUB 125
11420 PRINT@(23,0),;
11425 OPEN "I",1,TABLE$
11430 I=1
11435 IF EOF(1) THEN 11455
11440 INPUT#1,PAGE%(I),START%(I),MORE%(I),TYPE$(I)
11445 I=I+1
11450 GOTO 11435
11455 CLOSE 1
11460 NUMPAGES%=I-1
11465 '   SORT TABLE INTO PAGE # SEQUENCE
11470 FOR I=1 TO NUMPAGES%-1
11475 FOR J=I+1 TO NUMPAGES%
11480 IF PAGE%(I)>PAGE%(J) THEN 11485 ELSE 11505
11485 SWAP PAGE%(I),PAGE%(J)
11490 SWAP START%(I),START%(J)
11495 SWAP MORE%(I),MORE%(J)
11500 SWAP TYPE$(I),TYPE$(J)
11505 NEXT J
11510 NEXT I
11515 QNUM%=1
11520 FOR I=1 TO NUMPAGES%
11525 IF TYPE$(I)<>"?" THEN 11540
11530 QNUM%(I)=QNUM%
11535 QNUM%=QNUM%+1
11540 NEXT I
11545 '
11550 '   OPEN LESSON BUFFER AND START LESSON WITH PAGE 1
11555 OPEN "D",2,TEXT$,81
11560 FIELD 2,1 AS BUF1$,5 AS BUF2$,5 AS BUF3$,5 AS BUF4$,5
      AS BUF5$,5 AS BUF6$,5 AS BUF7$,1 AS BUF8$,3 AS BUF9$,4
      6 AS DUMMY$
11565 FIELD 2,1 AS BUF10$,80 AS BUF11$

```

```

11570 QPAGE%=1      'SET COUNTER FOR FIRST PAGE OF LESSON
11575 '
11580 '   FIND CORRESPONDING TABLE SUBSCRIPT
11585 COUNT%=1
11590 IF PAGE%(COUNT%)=QPAGE% THEN 11605
11595 COUNT%=COUNT%+1
11600 GOTO 11590
11605 QMAT%=COUNT%
11610 '
11615 '   READ DATA FOR A PAGE
11620 GET 2,START%(QMAT%)
11625 TYPE$=BUF1$
11630 AJUMP%=VAL(BUF3$)
11635 BJUMP%=VAL(BUF4$)
11640 CJUMP%=VAL(BUF5$)
11645 DJUMP%=VAL(BUF6$)
11650 EJUMP%=VAL(BUF7$)
11655 ANSWER$=BUF8$
11660 MORE%=VAL(BUF9$)
11665 '
11670 '   READ THE TEXT RECORDS FOR THIS PAGE
11675 FOR I=1 TO MORE%
11680 GET 2,(START%(QMAT%)+I)
11685 DUMMY$=BUF10$
11690 TEXT$(I)=BUF11$
11695 NEXT I
11700 '
11705 '   DECIDE ON PROPER INSTRUCTION LINE AND DISPLAY PAGE
11710 IF TYPE$="#" THEN QINST$=ENTERS$
11715 IF TYPE$="?" THEN QINST$=PROMPTS$
11720 QPAGE$=STR$(QPAGE%)
11725 QNAME$=TNAME$
11730 IF TYPE$="?" THEN TCOUNT%=TCOUNT%+1
11735 IF TYPE$="?" THEN QUEST$="QUESTION #"+STR$(QNUM%(QMAT%
    )) ELSE QUEST$=""
11740 GOSUB 125
11745 FOR I=1 TO MORE%
11750 PRINT TEXT$(I);
11755 NEXT I
11760 PRINT@(23,0),;
11765 '
11770 '   ROUTE TO PROPER LINE FOR HANDLING RESPONSE TO PAGE
    TYPE
11775 IF TYPE$="#" THEN 11795 'TEXT PAGE
11780 IF INSTR("ABCDE",ANSWER$)<>0 THEN 11820 'MULTIPLE
    CHOICE QUESTION
11785 IF INSTR("TF",ANSWER$)<>0 THEN 11880 'TRUE/FALSE
    QUESTION
11790 '
11795 '   HANDLE TEXT PAGE USER RESPONSE
11800 GOSUB 300
11805 QPAGE%=AJUMP%
11810 GOTO 11925

```

```

11815 '
11820 '   HANDLE MULTIPLE CHOICE QUESTION RESPONSE
11825 GOSUB 240
11830 IF A$="A" THEN QPAGE%=AJUMP%
11835 IF A$="B" THEN QPAGE%=BJUMP%
11840 IF A$="C" THEN QPAGE%=CJUMP%
11845 IF A$="D" THEN QPAGE%=DJUMP%
11850 IF A$="E" THEN QPAGE%=EJUMP%
11855 IF A$<>ANSWER$ THEN GOSUB 330
11860 IF A$=ANSWER$ THEN GOSUB 370
11865 GOSUB 300
11870 GOTO 11925
11875 '
11880 '   HANDLE TRUE/FALSE QUESTION RESPONSE
11885 GOSUB 270
11890 IF A$="T" THEN QPAGE%=AJUMP%
11895 IF A$="F" THEN QPAGE%=BJUMP%
11900 IF A$<>ANSWER$ THEN GOSUB 330
11905 IF A$=ANSWER$ THEN GOSUB 370
11910 GOSUB 300
11915 GOTO 11925
11920 '
11925 '   CHECK FOR BRANCH TO LAST PAGE
11930 IF QPAGE%=9999 THEN 11945
11935 GOTO 11580 '   REPEAT PROCESS FOR NEW PAGE
11940 '
11945 '   PRINT SCREEN WITH STUDENT RESULTS
11950 QNAME$=TNAME$:QINST$=ENTER$:QUEST$="":QPAGE$="":GOSUB
125
11955 GRADE%=(RCOUNT%/TCOUNT%)*100
11960 PRINT"During this lesson you were asked ";
11965 PRINT USING "###";TCOUNT%;
11970 PRINT" questions."
11975 PRINT
11980 PRINT"You answered ";
11985 PRINT USING "###";RCOUNT%;
11990 PRINT" correctly and ";
11995 PRINT USING "###";WCOUNT%;
12000 PRINT" incorrectly."
12005 PRINT
12010 PRINT"Your grade for this lesson is ";
12015 PRINT USING "###.";GRADE%
      :PRINT@(23,0),;
12020 GOSUB 300
12025 '
12030 '   END LESSON ROUTINE - WRITE STUDENT FILE
12035 CLOSE
      :IF TNAME$="INTRO" THEN 11165

```

```

12040 QNAME$="ENDING LESSON"
      :QPAGE$=""
      :QINST$=STRING$(20,32)+"Saving lesson results...pl
      ease wait."
      :QUEST$=""
      :GOSUB 125
12045 PRINT@(23,0),;
12050 '
12055 '   CHECK FOR EXISTING STUDENT FILE ON DRIVE 1 - OPEN
      IN CORRECT MODE
12060 '   WRITE DATA TO FILE
12065 STUFILE$=TNAME$+"/STU:1"
12070 QTEST$=STUFILE$
12075 GOSUB 150
12080 IF FLAG%=0 THEN OPEN "E",1,STUFILE$
12085 IF FLAG%=1 THEN OPEN "O",1,STUFILE$
12090 WRITE# 1, STUDENT$,DATE$,TCOUNT%,RCOUNT%,WCOUNT%
12095 FOR I=1 TO WCOUNT%
12100 WRITE# 1,WQUEST%(I),WQUEST$(I)
12105 NEXT I
12110 CLOSE
12115 '
12120 '   RETURN TO MAIN MENU
12125 GOTO 11165
12130 '
12135 '   TERMINATE SESSION ROUTINE
12140 CLOSE
12145 QNAME$="GOODBYE"
      :QINST$=""
      :QPAGE$=""
      :QUEST$=""
      :GOSUB 125
12150 PRINT "Thank you for using the LEARNER computer-assist
ed instruction"
12155 PRINT"system."
12160 PRINT
12165 PRINT"wait for the DOS ready prompt before removing di
sks or turning"
12170 PRINT"machine off!"
12175 PRINT@(23,0),;
12180 FOR I=1 TO 3000
      :NEXT I      '   DELAY LOOP TO DISPLAY LOGOFF MESSAGE
12185 CLOSE
      :SYSTEM
      :END
12190 '
12195 '   PROGRAM FATAL ERROR ROUTINE
12200 STAR$=STRING$(10,32)+STRING$(60,42)
12205 CLS
12210 PRINT@(3,0),STAR$:FOR I=4 TO 15
      :PRINT@(I,10),"***";:PRINT@(I,68),"***";
      :NEXT I
      :PRINT@(15,0),STAR$;

```

```
12215 PRINT@(5,21),"FATAL PROGRAM ERROR DURING EXECUTION";
12220 PRINT@(7,25),"Error code ";ERR;" in line ";ERL;
12225 PRINT@(10,15),"Copy above data and deliver to training
supervisor!";
12230 PRINT@(13,23),"Press <ENTER> to restart program.";
12235 PRINT@(13,22),;
12240 A$=INKEY$
      :IF A$<>CHR$(13) THEN 12240
12245 CLOSE
      :RESUME 11045
12250 END
```

LEARNER/BAS Program Listing (MSDOS Version)

```
1 '*****
2 '* LEARNER/BAS - COMPUTER-ASSISTED INSTRUCTION SOFTWARE *
3 '* ROBERT MASON, LT, SC, USN *
4 '* AIR FORCE INSTITUTE OF TECHNOLOGY *
5 '* SCHOOL OF SYSTEMS AND LOGISTICS *
6 '* MAY 1987 *
7 '* IBM/PC VERSION 01.00.00. *
8 '*****
9 '
10 GOTO 10000 'JUMP TO START OF MAIN PROGRAM
15 '
100 '*****
105 '* SUBROUTINES *
110 '* (LINES 100-9999) *
115 '*****
120 '
125 ' SUBROUTINE - PRINT SCREEN BOILERPLATE
130 CLS
      :LOCATE 1,1
      :PRINT QNAME$
      :LOCATE 1,77
      :PRINT QPAGE$
      :LOCATE 2,1
      :PRINT DASH$;
135 LOCATE 23,1
      :PRINT DASH$;
      :LOCATE 24,1
      :PRINT QINST$;
      :LOCATE 1,32
      :PRINT QUEST$;
      :LOCATE 3,1
140 RETURN
145 '
150 ' SUBROUTINE - CHECK FOR FILENAME ON DISK
155 FLAG%=0
160 ON ERROR GOTO 175
165 OPEN QTEST$ FOR INPUT AS #1
170 GOTO 200
175 IF ERR=53 THEN FLAG%=1
      :GOTO 195 ' FILE NOT FOUND ERROR
180 IF ERR=57 THEN FLAG%=2
      :GOTO 195 ' DEVICE I/O ERROR
195 IF ERR=64 THEN FLAG%=3
      :GOTO 195 ' BAD FILE NAME ERROR
190 FLAG%=4 ' UNKNOWN ERROR
195 RESUME 200
200 CLOSE
      :ON ERROR GOTO 12195:RETURN
205 '
210 ' SUBROUTINE - WAIT FOR Y/N INPUT
```

```

215 A$=INPUT$(1)
220 IF A$=CHR$(5) THEN 12145
225 IF INSTR("YN",A$)=0 THEN 215
230 RETURN
235 '
240 '   SUBROUTINE - WAIT FOR A/B/C/D/E INPUT
245 A$=INPUT$(1)
250 IF A$=CHR$(5) THEN 12145
255 IF INSTR("ABCDE",A$)=0 THEN 245
260 RETURN
265 '
270 '   SUBROUTINE - WAIT FOR T/F INPUT
275 A$=INPUT$(1)
280 IF A$=CHR$(5) THEN 12145
285 IF INSTR("TF",A$)=0 THEN 275
290 RETURN
295 '
300 '   SUBROUTINE - WAIT FOR <ENTER> INPUT
305 A$=INPUT$(1)
310 IF A$=CHR$(5) THEN 12145
315 IF A$<>CHR$(13) THEN 305
320 RETURN
325 '
330 '   SUBROUTINE - HANDLE INCORRECT RESPONSE
335 LOCATE 24,2
      :PRINT WANSWERS$;
340 LOCATE 24,1
345 WCOUNT%=WCOUNT%+1
350 WQUEST%(WCOUNT%)=QNUM%(QMAT%)
355 WQUEST$(WCOUNT%)=A$
360 RETURN
365 '
370 '   SUBROUTINE - HANDLE CORRECT RESPONSE
375 LOCATE 24,2
      :PRINT RANSWERS$;
380 LOCATE 24,1
385 RCOUNT%=RCOUNT%+1
390 RETURN
395 '
10000 '*****
10005 '*   CONSTANT TABLE AND DEFINED FUNCTIONS   *
10010 '*           (LINES 10000-10999)           *
10015 '*****
10020 DASH$=STRING$(80,45)
10025 ENTER$=STRING$(22,32)+"Press <ENTER> to continue."
10030 PROMPT$=STRING$(22,32)+"Press <letter> of your choice
      ."
10035 YINST$=STRING$(23,32)+"Press <Y>es or <N>o to continu
      e."
10040 QDATA$=STRING$(14,32)+"Enter requested data and press
      <ENTER> to continue."
10045 RANSWERS$="Right response!"+STRING$(14,32)+"Press <ENTE
      R> to continue."

```

```

10050 WANSWER$="Wrong response!" + STRING$(14,32) + "Press <ENTE
      R> to continue."
10055 '
11000 '*****
11005 '*                MAIN PROGRAM                *
11010 '*                (LINES 11000-39999)        *
11015 '*****
11020 '
11025 OPTION BASE 1
      :KEY OFF
      :ON ERROR GOTO 12195
11030 DIM PAGE%(200),START%(200),MORE%(200),TYPE$(200)
11035 DIM TEXT$(20),WQUEST%(200),WQUEST$(200),QNUM%(200)
11040 '
11045 ' PRINT SCREEN AND GET USER NAME
11050 QNAMES="MAIN MENU"
      :QINST$=QDATA$
      :QPAGES$=""
      :GOSUB 125
11055 PRINT"ENSURE THAT THE CAPS LOCK KEY IS DEPRESSED AND R
      EMAINS"
11060 PRINT"DEPRESSED FOR THE DURATION OF THIS LESSON!"
11065 PRINT
11070 PRINT"Input your first initial and last name in capita
      l letters with"
11075 INPUT"no space (example: RSMITH): ",STUDENT$
      :IF STUDENT$="" THEN 11045
11080 '
11085 ' CHECK FOR CAPITAL INPUT - REPEAT IF NECESSARY
11090 TEST%=ASC(LEFT$(STUDENT$,1))
11095 IF TEST%>=65 AND TEST%<=90 THEN 11115
11100 PRINT
      :PRINT"Erroneous input...ensure that the caps lock
      key is depressed!"
      :PRINT
11105 GOTO 11070
11110 '
11115 ' OFFER TO RUN INTRODUCTORY LESSON
11120 QNAMES="MAIN MENU"
      :QINST$=YNINST$
      :QPAGES$=""
      :GOSUB 125
11125 LOCATE 3,1
      :PRINT"Do you want to run a short introductory
      lesson about this"
11130 PRINT"computer-assisted instruction program before
      starting a lesson?"
11135 LOCATE 24,1
11140 GOSUB 210
11145 IF A$="N" THEN 11165
11150 TNAME$="INTRO" ' RUN INTRO LESSON
11155 GOTO 11215
11160 '

```

```

11165 ' PRINT SCREEN, LESSON CATALOGUE, AND GET LESSON
      FILE NAME
11170 QNAME$="MAIN MENU"
      :QINST$=QDATA$
      :QPAGE$=""
      :QUEST$=""
      :GOSUB 125
11175 LOCATE 3,1:PRINT"The following lesson files are availa
      ble on this disk:"
11180 PRINT
11185 FILES "A:*.TXT"
      :LOCATE CSRLIN-1,1
      :PRINT STRING$(80-POS(0),32)
11190 PRINT
      :PRINT
      :INPUT"Enter lesson to run or change data disk and
      press <ENTER>: ",TNAME$
11195 IF INAME$="" THEN 11165 'NEW DISK CATALOG
11200 IF TNAME$="Q" THEN 12145
11205 IF INSTR(TNAME$,".")=0 THEN 11215
11210 TNAME$=LEFT$(TNAME$,(INSTR(TNAME$,".")-1))
11215 TEXT$="A:"+TNAME$+".TXT"
11220 TABLE$="A:"+TNAME$+".TAB"
11225 '
11230 ' CHECK FOR LESSON TEXT FILE ON DISK, PRINT ERROR
      MESSAGE, AND
11235 ' RETURN TO MAIN MENU IF NECESSARY
11240 QTEST$=TEXT$
      :GOSUB 150
11245 IF FLAG%=0 THEN 11310
11250 QNAME$="ERROR"
      :QINST$=ENTERS
      :QPAGE$=""
      :GOSUB 125
11255 ON FLAG% GOTO 11260,11265,11275,11280
11260 PRINT TNAME$;" is not on these disks."
      :GOTO 11290
11265 PRINT"A device input/output error has occurred!"
11270 PRINT"Terminate this session and contact your training
      supervisor."
      :GOTO 11290
11275 PRINT TNAME$;" is not a valid lesson name."
      :GOTO 11290
11280 PRINT"An unknown disk error has occurred!"
11285 PRINT"Terminate this session and contact your training
      supervisor."
      :GOTO 11290
11290 LOCATE 24,1
11295 GOSUB 300
11300 GOTO 11165
11305 '
11310 ' CHECK FOR LESSON TABLE FILE ON DISK, PRINT ERROR
      MESSAGE, AND

```

```

11315 ' RETURN TO MAIN MENU IF REQUIRED
11320 QTEST$=TABLE$
        :GOSUB 150
11325 IF FLAG%=0 THEN 11380
11330 QNAME$="ERROR"
        :QINST$=ENTER$
        :QPAGE$=""
        :GOSUB 125
11335 PRINT"Unable to run this lesson...the corresponding le
        sson table"
11340 PRINT"file is not on these disks."
11345 PRINT
        :PRINT"Contact your training supervisor to make co
        rrections to"
11350 PRINT"this lesson disk."
11355 PRINT
        :PRINT"You may try another lesson or terminate thi
        s session."
11360 LOCATE 24,1
11365 GOSUB 300
11370 GOTO 11165
11375 '
11380 ' INITIALIZE QUESTION COUNTERS AND ARRAYS
11385 TCOUNT%=0
        :RCOUNT%=0
        :WCOUNT%=0
11390 ERASE PAGE%,START%,MORE%,TYPE$
11395 ERASE TEXT$,WQUEST%,WQUEST$,QNUM%
11400 DIM PAGE%(200),START%(200),MORE%(200),TYPE$(200)
11405 DIM TEXT$(20),WQUEST%(200),WQUEST$(200),QNUM%(200)
11410 ' READ LESSON TABLE
11415 QNAME$=TNAME$
        :QINST$=STRING$(20,32)+"Loading lesson table...ple
        ase wait..."
        :QPAGE$=""
        :GOSUB 125
11420 LOCATE 24,1
11425 OPEN TABLE$ FOR INPUT AS #1
11430 I=1
11435 IF EOF(1) THEN 11455
11440 INPUT #1,PAGE%(I),START%(I),MORE%(I),TYPE$(I)
11445 I=I+1
11450 GOTO 11435
11455 CLOSE
11460 NUMPAGES%=I-1
11465 ' SORT TABLE INTO PAGE # SEQUENCE
11470 FOR I=1 TO NUMPAGES%-1
11475 FOR J=I+1 TO NUMPAGES%
11480 IF PAGE%(I)>PAGE%(J) THEN 11485 ELSE 11505
11485 SWAP PAGE%(I),PAGE%(J)
11490 SWAP START%(I),START%(J)
11495 SWAP MORE%(I),MORE%(J)
11500 SWAP TYPE$(I),TYPE$(J)

```

```

11505 NEXT J
11510 NEXT I
11515 QNUM%=1
11520 FOR I=2 TO NUMPAGES%
11525 IF TYPE$(I)<>"?" THEN 11540
11530 QNUM%(I)=QNUM%
11535 QNUM%=QNUM%+1
11540 NEXT I
11545 '
11550 ' OPEN LESSON BUFFER AND START LESSON WITH PAGE 1
11555 OPEN TEXT$ AS #2 LEN=81
11560 FIELD #2,1 AS BUF1$,5 AS BUF2$,5 AS BUF3$,5 AS BUF4$,5
      AS BUF5$,5 AS BUF6$,5 AS BUF7$,1 AS BUF8$,3 AS BUF9$,
      46 AS DUMMY$
11565 FIELD #2,1 AS BUF10$,80 AS BUF11$
11570 QPAGE%=1 'SET COUNTER FOR FIRST PAGE OF LESSON
11575 '
11580 ' FIND CORRESPONDING TABLE SUBSCRIPT
11585 COUNT%=1
11590 IF PAGE%(COUNT%)=QPAGE% THEN 11605
11595 COUNT%=COUNT%+1
11600 GOTO 11590
11605 QMAT%=COUNT%
11610 '
11615 ' READ DATA FOR A PAGE
11620 GET #2,START%(QMAT%)
11625 TYPE$=BUF1$
11630 AJUMP%=VAL(BUF3$)
11635 BJUMP%=VAL(BUF4$)
11640 CJUMP%=VAL(BUF5$)
11645 DJUMP%=VAL(BUF6$)
11650 EJUMP%=VAL(BUF7$)
11655 ANSWER$=BUF8$
11660 MORE%=VAL(BUF9$)
11665 '
11670 ' READ THE TEXT RECORDS FOR THIS PAGE
11675 FOR I=1 TO MORE%
11680 GET #2,(START%(QMAT%)+I)
11685 DUMMY$=BUF10$
11690 TEXT$(I)=BUF11$
11695 NEXT I
11700 '
11705 ' DECIDE ON PROPER INSTRUCTION LINE AND DISPLAY PAGE
11710 IF TYPE$="#" THEN QINST$=ENTER$
11715 IF TYPE$="?" THEN QINST$=PROMPT$
11720 QPAGE$=STR$(QPAGE%)
11725 QNAME$=TNAME$
11730 IF TYPE$="?" THEN TCOUNT%=TCOUNT%+1
11735 IF TYPE$="?" THEN QUEST$="QUESTION #"+STR$(QNUM%(QMAT%
      )) ELSE QUEST$=""
11740 GOSUB 125
11745 FOR I=1 TO MORE%
11750 PRINT TEXT$(I);

```

```

11755 NEXT I
11760 LOCATE 24,1
11765 '
11770 '   ROUTE TO PROPER LINE FOR HANDLING RESPONSE TO PAGE
        TYPE
11775 IF TYPE$="#" THEN 11795   'TEXT PAGE
11780 IF INSTR("ABCDE",ANSWER$)<>0 THEN 11820   'MULTIPLE
        CHOICE QUESTION
11785 IF INSTR("TF",ANSWER$)<>0 THEN 11880   'TRUE/FALSE
        QUESTION
11790 '
11795 '   HANDLE TEXT PAGE USER RESPONSE
11800 GOSUB 300
11805 QPAGE%=AJUMP%
11810 GOTO 11925
11815 '
11820 '   HANDLE MULTIPLE CHOICE QUESTION RESPONSE
11825 GOSUB 240
11830 IF A$="A" THEN QPAGE%=AJUMP%
11835 IF A$="B" THEN QPAGE%=BJUMP%
11840 IF A$="C" THEN QPAGE%=CJUMP%
11845 IF A$="D" THEN QPAGE%=DJUMP%
11850 IF A$="E" THEN QPAGE%=EJUMP%
11855 IF A$<>ANSWER$ THEN GOSUB 330
11860 IF A$=ANSWER$ THEN GOSUB 370
11865 GOSUB 300
11870 GOTO 11925
11875 '
11880 '   HANDLE TRUE/FALSE QUESTION RESPONSE
11885 GOSUB 270
11890 IF A$="T" THEN QPAGE%=AJUMP%
11895 IF A$="F" THEN QPAGE%=BJUMP%
11900 IF A$<>ANSWER$ THEN GOSUB 330
11905 IF A$=ANSWER$ THEN GOSUB 370
11910 GOSUB 300
11915 GOTO 11925
11920 '
11925 '   CHECK FOR BRANCH TO LAST PAGE
11930 IF QPAGE%=9999 THEN 11945
11935 GOTO 11580   '   REPEAT PROCESS FOR NEW PAGE
11940 '
11945 '   PRINT SCREEN WITH STUDENT RESULTS
11950 QNAME$=TNAME$
        :QINST$=ENTERS$
        :QUEST$=""
        :QPAGE$=""
        :GOSUB 125
11955 GRADE%=(RCOUNT%/TCOUNT%)*100
11960 PRINT"During this lesson you were asked ";
11965 PRINT USING "###";TCOUNT%;
11970 PRINT" questions."
11975 PRINT
11980 PRINT"You answered ";

```

```

11985 PRINT USING "###";RCOUNT%;
11990 PRINT" correctly and ";
11995 PRINT USING "###";WCOUNT%;
12000 PRINT" incorrectly."
12005 PRINT
12010 PRINT"Your grade for this lesson is ";
12015 PRINT USING "###.";GRADE%
          :LOCATE 24,1
12020 GOSUB 300
12025 '
12030 '   END LESSON ROUTINE - WRITE STUDENT FILE
12035 CLOSE
          :IF TNAME$="INTRO" THEN 11165
12040 QNAME$="ENDING LESSON"
          :QPAGES$=""
          :QINST$=STRING$(20,32)+"Saving lesson results...pl
          ease wait."
          :QUEST$=""
          :GOSUB 125
12045 LOCATE 24,1
12050 '
12055 '   CHECK FOR EXISTING STUDENT FILE ON DRIVE 1 - OPEN
          IN CORRECT MODE
12060 '   WRITE DATA TO FILE
12065 STUFILES$="A:"+TNAME$+".STU"
12070 QTEST$=STUFILES$
12075 GOSUB 150
12080 IF FLAG%=0 THEN OPEN STUFILES$ FOR APPEND AS #1
12085 IF FLAG%=1 THEN OPEN STUFILES$ FOR OUTPUT AS #1
12090 WRITE# 1, STUDENT$,DATE$,TCOUNT%,RCOUNT%,WCOUNT%
12095 FOR I=1 TO WCOUNT%
12100 WRITE# 1,WQUEST%(I),WQUEST$(I)
12105 NEXT I
12110 CLOSE
12115 '
12120 '   RETURN TO MAIN MENU
12125 GOTO 11165
12130 '
12135 '   TERMINATE SESSION ROUTINE
12140 CLOSE
12145 QNAME$="GOODBYE"
          :QINST$=""
          :QPAGES$=""
          :QUEST$=""
          :GOSUB 125
12150 PRINT "Thank you for using the LEARNER computer-assist
ed instruction"
12155 PRINT"system."
12160 PRINT
12165 PRINT"wait for the DOS ready prompt before removing di
sks or turning"
12170 PRINT"machine off!"
12175 LOCATE 24,1

```

```

12180 FOR I=1 TO 3000:NEXT I      '   DELAY LOOP TO DISPLAY
      LOGOFF MESSAGE
12185 CLOSE
      :SYSTEM
      :END

12190 '
12195 '   PROGRAM FATAL ERROR ROUTINE
12200 STAR$=STRING$(10,32)+STRING$(60,42)
12205 CLS
12210 LOCATE 4,1
      :PRINT STAR$
      :FOR I=5 TO 16
      :LOCATE I,11
      :PRINT "***";
      :LOCATE I,69
      :PRINT "***";
      :NEXT I
      :LOCATE 16,1
      :PRINT STAR$;
12215 LOCATE 6,22
      :PRINT"FATAL PROGRAM ERROR DURING EXECUTION";
12220 LOCATE 8,26
      :PRINT"Error code ";ERR;" in line ";ERL;
12225 LOCATE 11,16
      :PRINT"Copy above data and deliver to training sup
      ervisor!";
12230 LOCATE 14,24
      :PRINT"Press <ENTER> to restart program.";
12235 LOCATE 14,23
12240 A$=INKEY$
      :IF A$<>CHR$(13) THEN 12240
12245 CLOSE
      :RESUME 11045
12250 END

```

Appendix B: LEARNER/BAS Courseware Example

This appendix contains example courseware generated by the LEARNER/BAS program. Figure B.1 contains hardcopy prints of screens as they appear during lesson execution. The courseware illustrated is the introductory lesson. Although all possible screens have not been shown, a representative sample has been illustrated.

MAIN MENU

ENSURE THAT THE CAPS LOCK KEY IS DEPRESSED AND REMAINS
DEPRESSED FOR THE DURATION OF THIS LESSON!

Input your first initial and last name in capital letters with
no space (example: RSMITH):

Enter requested data and press <ENTER> to continue.

LEARNER/BAS main menu and input of student
name. Throughout lesson, lesson information
appears on top line of screen and user
instructions on bottom line of screen.

Figure B.1: LEARNER/BAS Courseware Example

MAIN MENU

ENSURE THAT THE CAPS LOCK KEY IS DEPRESSED AND REMAINS
DEPRESSED FOR THE DURATION OF THIS LESSON!

Input your first initial and last name in capital letters with
no space (example: RSMITH): djohnson

Erroneous input...ensure that the caps lock key is depressed!

Input your first initial and last name in capital letters with
no space (example: RSMITH):

Enter requested data and press <ENTER> to continue.

Program checks initial character of student
name for upper-case input. If not upper-case
this error message is displayed and request
for student name displayed again.

Figure B.1: LEARNER/BAS Courseware Example (continued)

MAIN MENU

Do you want to run a short introductory lesson about this
computer-assisted instruction program before starting a lesson?

Press <Y>es or <N>o to continue.

Program asks if introductory lesson is to be run. If student answers with <N> key then program branches to display of lesson files available on disk.

Figure B.1: LEARNER/BAS Courseware Example (continued)

INTRO

Loading lesson table...please wait...

Temporary screen display while lesson table
file is being loaded into computer memory
disk.

Figure B.1: LEARNER/BAS Courseware Example (continued)

INTRO

1

welcome to the LEARNER computer-assisted instruction program introduction. This is an introductory lesson to provide practice with the computer program before using actual lesson material.

Look at the bottom line of this screen. It tells you to press the <ENTER> key to continue. Each screen of the lesson will remain on the screen until you take the action described on the bottom line of the screen. Don't worry about pressing the wrong key - the computer will not respond until you press one of the allowable keys.

Some computers do not have an <ENTER> key, but have a similiar key that performs the same function. This key is the same as the <RETURN> key on a typewriter and should be used whenever you are requested to press the <ENTER> key.

Now let's continue with the rest of this introductory lesson. Look at the bottom line of the screen and press the proper key to continue.

Press <ENTER> to continue.

First screen of the introductory lesson illustrating a typical text page. Note that the lesson information line displays the lesson filename being executed and the lesson screen page number.

Figure B.1: LEARNER/BAS Courseware Example (continued)

Good...you understand how to continue the lesson from a page of text!

The screen you are reading and the previous screen are examples of text screens. Text screens will give you factual information about the lesson subject. You should read these pages carefully and attempt to remember the important information. You should not spend too much time on each page trying to memorize each line. Computer-assisted instruction should be fun. Read the material and continue each screen at a comfortable pace. The program will ensure that you have an adequate grasp of the subject material before continuing the lesson.

Now look at the top line of the screen. On the left you will see the title of the lesson you are running. This title is up to eight characters which is the name of the files on the disk. On the right is the screen number of the screen you are reading. Do not worry if these screen numbers do not come in order or jump around. These numbers are used for lesson branching and are simply a reference number for you and the lesson author.

(Before pressing the <ENTER> key to continue this lesson, try pressing other keys to see what effect they have on the computer.)

Press <ENTER> to continue.

Second screen of the introductory lesson.

Figure B.1: LEARNER/BAS Courseware Example (continued)

See? Pressing the wrong key has no effect on the computer program. You cannot damage the program, the computer, or the lesson material by pressing the wrong key on the computer.

Press <ENTER> to continue.

Third screen of the introductory lesson.

Figure B.1: LEARNER/BAS Courseware Example (continued)

This screen is a sample of a multiple choice question. Look at the instruction line. It no longer says press the <ENTER> key to continue. Instead, you should press the letter key of your answer choice. Do not press the <ENTER> key after the letter key. Press only the letter key of your answer choice. Also, look at the top line of the screen. The number of this question is displayed on this line as well as the lesson title and screen number. Now the question...

If you press the <ENTER> key now, what effect would this have on the computer?

- <A> No effect - it's not one of the allowable keys on the instruction line.
- The computer would probably break.
- <C> The training supervisor would get very angry.
- <D> All the computer disks would be erased.
- <E> The computer program would be destroyed.

Press <letter> of your choice.

Fourth screen of the introductory lesson illustrating a typical multiple-choice question page. This particular screen combines text information with a multiple-choice question. Note that the question is displayed on the information line and the instruction line requests that the user press a letter key.

AD-A187 268

A GENERAL APPLICATION COMPUTER-ASSISTED INSTRUCTION
SYSTEM FOR MICROCOMPUTERS(U) AIR FORCE INST OF TECH
WRIGHT-PATTERSON AFB OH SCHOOL OF SVST.. R MASON
SEP 87 AFIT/GLM/LSR/87S-45

2/3

UNCLASSIFIED

F/G 12/5

NL

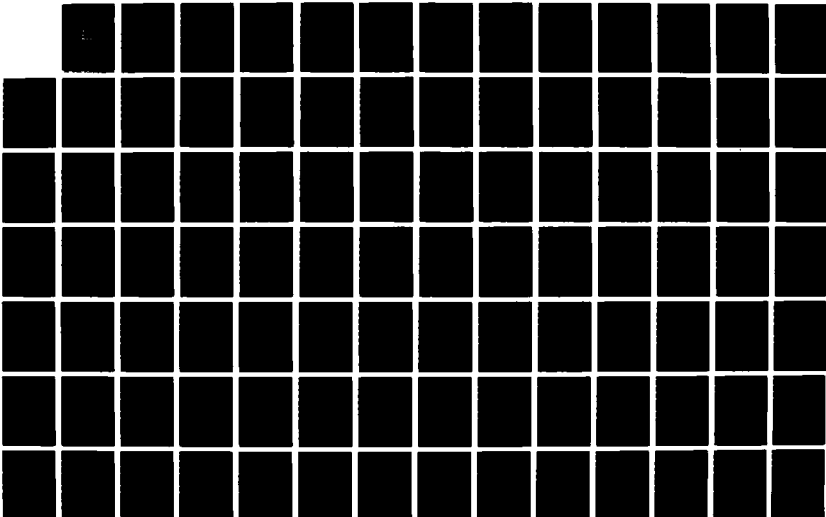

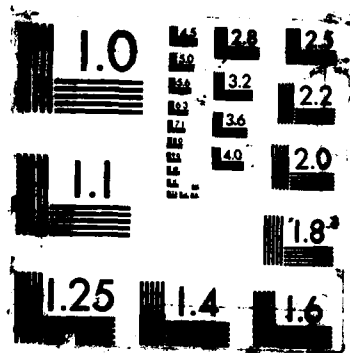

This screen is a sample of a multiple choice question. Look at the instruction line. It no longer says press the <ENTER> key to continue. Instead, you should press the letter key of your answer choice. Do not press the <ENTER> key after the letter key. Press only the letter key of your answer choice. Also, look at the top line of the screen. The number of this question is displayed on this line as well as the lesson title and screen number. Now the question...

If you press the <ENTER> key now, what effect would this have on the computer?

- <A> No effect - it's not one of the allowable keys on the instruction line.
- The computer would probably break.
- <C> The training supervisor would get very angry.
- <D> All the computer disks would be erased.
- <E> The computer program would be destroyed.

Wrong response!

Press <ENTER> to continue.

Fourth screen of the introductory lesson illustrating a typical multiple-choice question page following an incorrect question response by the student.

Figure B.1: LEARNER/BAS Courseware Example (continued)

No...remember pressing a key not allowed has no effect on the computer.
You cannot damage the computer, the disks, or programs by pressing the wrong key
during lesson execution.

Press <ENTER> to continue.

Screen displayed in the introductory lesson if student responded incorrectly to question #1. This screen illustrates the use of remedial information following an incorrect question response.

Figure B.1: LEARNER/BAS Courseware Example (continued)

The correct answer was <A>, of course. Multiple choice questions are one of two types of questions you will encounter during lessons. Remember, press only the <letter> key of your answer choice and do not press the <ENTER> key after the <letter> key. If the computer does not seem to respond to your entry, check the <CAPS LOCK> key to ensure that it is depressed. This program will accept only capital letter input during the lesson.

Now let's look at the other type of question you will see during a lesson.

Press <ENTER> to continue.

Fifth screen of the introductory lesson.

Figure B.1: LEARNER/BAS Courseware Example (continued)

This screen is an example of a true/false question. Notice that the allowable letter keys have changed. Now you must press the <T> or <F> key to select your answer. Again, do not press the <ENTER> key after your response. Press only the letter key of your answer.

True/False: To respond with true to a true/false question, you should press the <A> key.

<T>true
<F>false

Press <letter> of your choice.

Sixth screen of the introductory lesson illustrating a typical true/false question screen. Again, this screen combines text information with the question.

Figure B.1: LEARNER/BAS Courseware Example (continued)

INTRO

QUESTION # 2

60

This screen is an example of a true/false question. Notice that the allowable letter keys have changed. Now you must press the <T> or <F> key to select your answer. Again, do not press the <ENTER> key after your response. Press only the letter key of your answer.

True/False: To respond with true to a true/false question, you should press the <A> key.

<T>true
<F>false

Right response!

Press <ENTER> to continue.

Sixth screen of the introductory lesson illustrating a typical true/false question screen following a correct question response by the student.

Figure B.1: LEARNER/BAS Courseware Example (continued)

The answer, of course, is false. For true/false questions, the allowable answer keys are <T> and <F>.

Okay, so the program has you read material and answer questions. So what? Well, based on your answers to the various questions, the computer will display different screens. If you get an answer wrong, the computer will probably repeat a page of text or provide you with a new page of text to ensure that you understand the material before proceeding. Pretty neat, huh? Remember, computer assisted-instruction should be fun!

Press <ENTER> to continue.

Seventh screen of the introductory lesson.

Figure B.1: LEARNER/BAS Courseware Example (continued)

This completes the introductory lesson to the LEARNER computer-assisted instruction system. You should also read the LEARNER User's Guide for additional information on the computer and this program.

Press <ENTER> now to return to the LEARNER Main Menu.

Press <ENTER> to continue.

Final screen of the introductory lesson. The jump page for this screen is "9999" which terminates the lesson execution and branches to the end of lesson routine.

Figure B.1: LEARNER/BAS Courseware Example (continued)

INTRO

During this lesson you were asked 2 questions.

You answered 1 correctly and 1 incorrectly.

Your grade for this lesson is 50.

Press <ENTER> to continue.

Display of student information provided after lesson termination. The total questions asked will probably not match the total questions in the lesson due to repeated question screens in the lesson branching instructions. This information is also recorded in the student disk file for analysis by the courseware author.

Figure B.1: LEARNER/BAS Courseware Example (continued)

MAIN MENU

The following lesson files are available on this disk:

Drive :1 DATADISK 40 Cyl, EDEN, Free = 172.50K / 180.00K, Date 13-Jul-87

LESSON1/TXT +

Enter lesson to run or change data disk and press <ENTER>:

Enter requested data and press <ENTER> to continue.

Display of the lesson catalogue. This screen is generated by displaying the files on the disk with an extension of "/TXT" or ".TXT". The student may enter the lesson filename to run, change the disk and press <ENTER> to display a new catalogue, or enter <Q><ENTER> to end program execution.

Figure B.1: LEARNER/BAS Courseware Example (continued)

ERROR

Unable to run this lesson...the corresponding lesson table
file is not on these disks.

Contact your training supervisor to make corrections to
this lesson disk.

You may try another lesson or terminate this session.

Press <ENTER> to continue.

Typical error message following erroneous
input of lesson name. Pressing <ENTER> at
this point returns the program to the main
menu/lesson catalogue display.

Figure B.1: LEARNER/BAS Courseware Example (continued)

GOODBYE

Thank you for using the LEARNER computer-assisted instruction system.

wait for the DOS ready prompt before removing disks or turning machine off!

Screen display following a <Q><ENTER> input at the main menu/lesson catalogue display. This message is displayed for a short period while applicable disk files are closed then exits BASIC and returns to the DOS ready prompt.

Figure B.1: LEARNER/BAS Courseware Example (continued)

```
*****  
**  
**          FATAL PROGRAM ERROR DURING EXECUTION          **  
**  
**          Error code 57 in line 65535                    **  
**  
**          Copy above data and deliver to training supervisor! **  
**  
**          Press <ENTER> to restart program.              **  
**  
*****
```

Screen display following a fatal error during program execution. Pressing <ENTER> closes disk files, erases variables in memory, and returns to the main menu/lesson catalogue prompt.

Figure B.1: LEARNER/BAS Courseware Example (continued)

Appendix C: LEARNER/BAS User's Guide

Contents

	Page
Introduction.	C- 2
Notes for Courseware Administrators	C- 3
Getting Started	C- 4
Stopping Sessions	C- 6
Error Messages.	C- 7

Introduction

LEARNER/BAS is a program written in the BASIC programming language which is one component of the WRITE-LEARNER computer-assisted instruction system. LEARNER will administer interactive, computer-assisted instruction courseware developed with the WRITE/BAS program.

This user's guide is intended to provide the knowledge required to use the LEARNER program with a minimum of computer knowledge.

During lessons, the student will use three different types of screens - text screens, multiple choice question screens, and true/false question screens. By using the various screens, the student should increase his knowledge of the subject area.

Notes for Courseware Administrators

This user's guide is primarily for use with a Tandy-Radio Shack Model IV or Zenith Z-248 microcomputer system. With the wide diversity of MS-DOS and TRSDOS computers available and the diversity of operating systems and disk-operating system "shells" in use, an "all-encompassing" user's guide for this system is not practicable. This guide is being copied (as written) in ASCII format on the WRITE-LEARNER distribution disk. Courseware administrators will use this guide to develop local instructions depending on computers available and operating systems in use. Also, the use of job control language files (Model IV) or auto-batch command files (MS-DOS) to start the program is encouraged.

The user may need some BASIC programming knowledge depending on local computer configuration. The LEARNER program is configured to operate with the system disk on a disk drive designated drive 1 (TRS-DOS) or A (MS-DOS). If the local computer configuration does not permit this, lines 11215, 11220, and 12065 will require modification to include the correct drive designation.

Getting Started

LEARNER operates under the BASIC programming language using data disks from the WRITE-LEARNER package and locally developed courseware data disks. To start a lesson, take the following actions:

- Step 1 Turn on the computer and monitor.
- Step 2 Load BASIC into the computer. On Air Force Institute of Technology (AFIT) Z-248's, this is accomplished by pressing the key while at the main menu display. On the Model IV, type "BASIC <ENTER>" at the DOS ready prompt.
- Step 3 Insert the WRITE-LEARNER system disk in drive A (Z-248) or drive 1 (Model IV).
- Step 4 Depending on computer configuration, type one of the following lines exactly as it appears then press the <ENTER> key:

```
RUN "A:LEARNER.BAS" (Z-248)  
RUN "LEARNER/BAS:1" (Model IV)
```
- Step 5 The LEARNER main menu will be displayed at this point. Ensure that the <CAPS LOCK> key is depressed. Enter your name as instructed by the program. Enter your first initial and last name with no space and press the <ENTER> key. If the <CAPS LOCK> key has not been depressed, the program will respond with an error message.
- Step 6 After entering your name, the program will ask if you want to run a short introductory lesson about the LEARNER computer-assisted instruction program before starting a lesson. Respond to this question by pressing the <Y> or <N> key. Do not press the <ENTER> key after your response. Press only the <Y> or <N> key.
- Step 7 If you respond to the introductory lesson question with <Y>, a short lesson will be run to give practice with the program. Follow the lesson prompts exactly - this program will not let you damage the computer, lessons, or disks. After the introductory lesson, the program will display the lesson catalogue as if you had pressed <N>. You may continue with step 8 from this point.

- Step 8 If you respond to the introductory lesson question with <N>, the program will display the lesson files available on the disk in drive A (Z-248) or drive 1 (Model IV). If you do not see a lesson that you want to run, change the disk and press the <ENTER> key - a new lesson catalogue will be displayed. If a lesson is on the disk that you want to take, enter the lesson name (up to eight characters exactly as they appear on the catalogue) and press the <ENTER> key. The lesson will start after a short loading period.
- Step 9 If you desire to terminate a session from an "Enter lesson to run or change data disk and press <ENTER>" prompt, enter the letter Q as the lesson name and press <ENTER>. The program will quit the session and return to the DOS ready prompt or a SHELL main menu display.

That's all the prerequisite knowledge required to operate the LEARNER program. The computer will prompt at virtually every step. Just take the action described on the instruction line of the display and you can't go wrong!

Stopping Sessions

You should complete each lesson started. At the end of a lesson, the program will return to a lesson catalogue prompt. Again, enter the letter Q at this prompt and press <ENTER> to terminate the program. At any point in the lesson execution, you can press the <CTRL> key and <E> key together to terminate the lesson early. However, if you stop the session early, your results will not be recorded.

Error Messages

As with any computer program, every precaution has been taken to ensure that the program is error free; however, unforeseen errors may occur. In the event that an error occurs, an error message will appear on the screen. You should copy the data as displayed and deliver it to your training supervisor for resolution. By pressing <ENTER> at the error message, the program will be restarted.

Appendix D: WRITE/BAS Program Documentation

Contents

	Page
WRITE/BAS Program Overview.	D- 2
WRITE/BAS Variable List	D-12
WRITE/BAS Record File Formats	D-15
WRITE/BAS BASIC Variables Cross-Reference List.	D-20
WRITE/BAS Line Number Cross-Reference List.	D-26
WRITE/BAS BASIC Keywords Cross-Reference List	D-29
WRITE/BAS Program Listing (TRSDOS Version).	D-35
WRITE/BAS Program Listing (MSDOS Version)	D-55

WRITE/BAS Program Overview

WRITE/BAS is a program written in the BASIC programming language which is one component of the WRITE-LEARNER computer-assisted instruction system. The system was developed on a Tandy/Radio Shack Model IV microcomputer and subsequently converted and tested on a Zenith Z-248 (IBM PC compatible) microcomputer. WRITE/BAS assists in the development of interactive, computer-assisted instruction courseware modules for use by the LEARNER/BAS program.

This appendix contains the documentation for the WRITE/BAS program. Included are comments about program operation; block diagrams to illustrate the program logic; a description of the variables used in the program; cross-reference listings by variable name, line number, and BASIC keywords; and the program listings (TRSDOS and MSDOS versions). A user's guide for the program is included as a separate appendix.

WRITE/BAS is essentially a specialized data-base manager with limited word processing capabilities. Lesson courseware is stored in formatted, direct-access, disk records which are written as required during lesson development. A header records contains certain data about a lesson page (page type, page number, and jump pages). Following the header record are from 1 to 20 text records which comprise the lesson page. A second file, a sequential ASCII lesson table file, is generated from the lesson text

file for reading into memory during lesson execution or lesson file editing to allow improved response times in locating records in the text file. A third file, a sequential ASCII student file, is generated during lesson execution and stores student data (student name, date lesson executed, and total/correct/incorrect question responses) about lesson use. WRITE/BAS uses this last file to produce hardcopy student file reports for use by courseware developers. Refer to the WRITE/BAS Record File Formats for a description of these files.

Figure D.1 is a simplified block diagram illustrating the operation of WRITE/BAS. Line numbers refer to both version of the program (i.e., TRSDOS and MSDOS) since line number consistency was maintained during program conversion.

If attempting to compile this program or convert it to operate on another type of computer, several cautions are in order. First, the program uses REMARK line numbers in program flow. GOTO and GOSUB commands must be changed to reflect deletions of REMARK statements. Second, the MSDOS version of WRITE/BAS emulates certain functions of the TRSDOS version (PRINT CHR\$(30) in TRSDOS BASIC erases display to end of current line which was emulated in MSDOS BASIC by LOCATE xx,yy:PRINT STRING\$(81-POS(0),32);:LOCATE xx,yy). Conversion should begin using the TRSDOS version program listing since this was the original program developed and the cross-reference listings included in this appendix refer to this version.

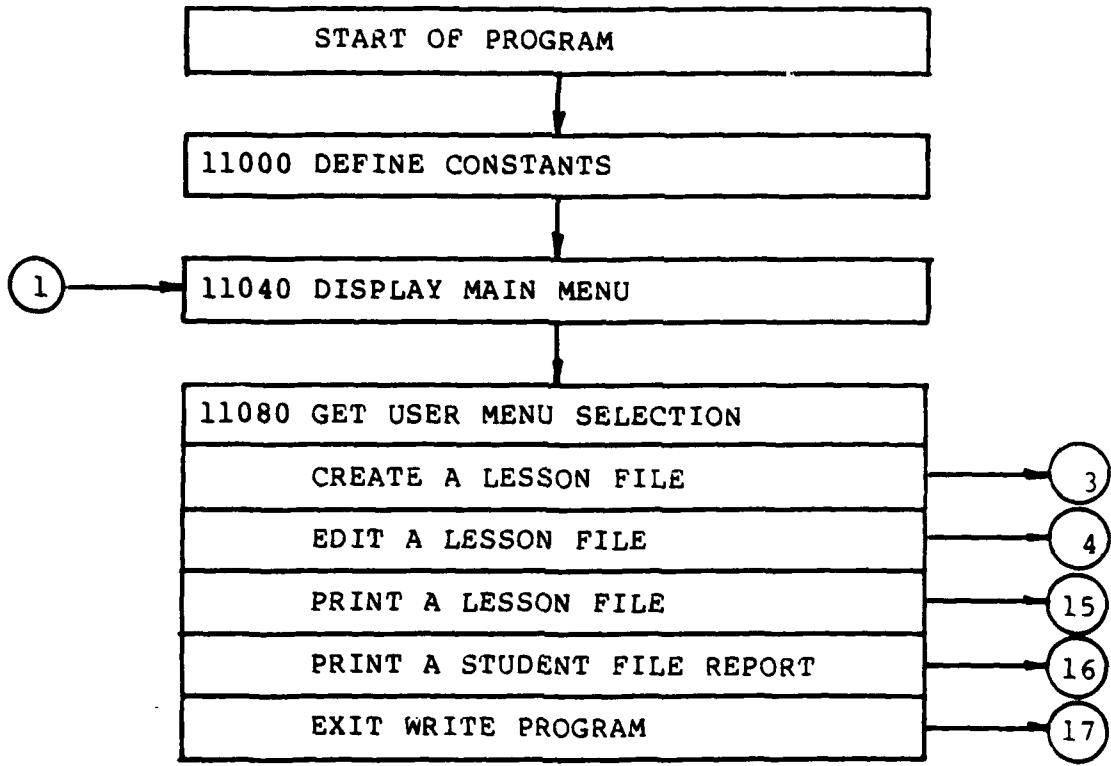

NOTE: (n) indicates branch to corresponding (n).

Figure D.1: WRITE/BAS Block Diagram

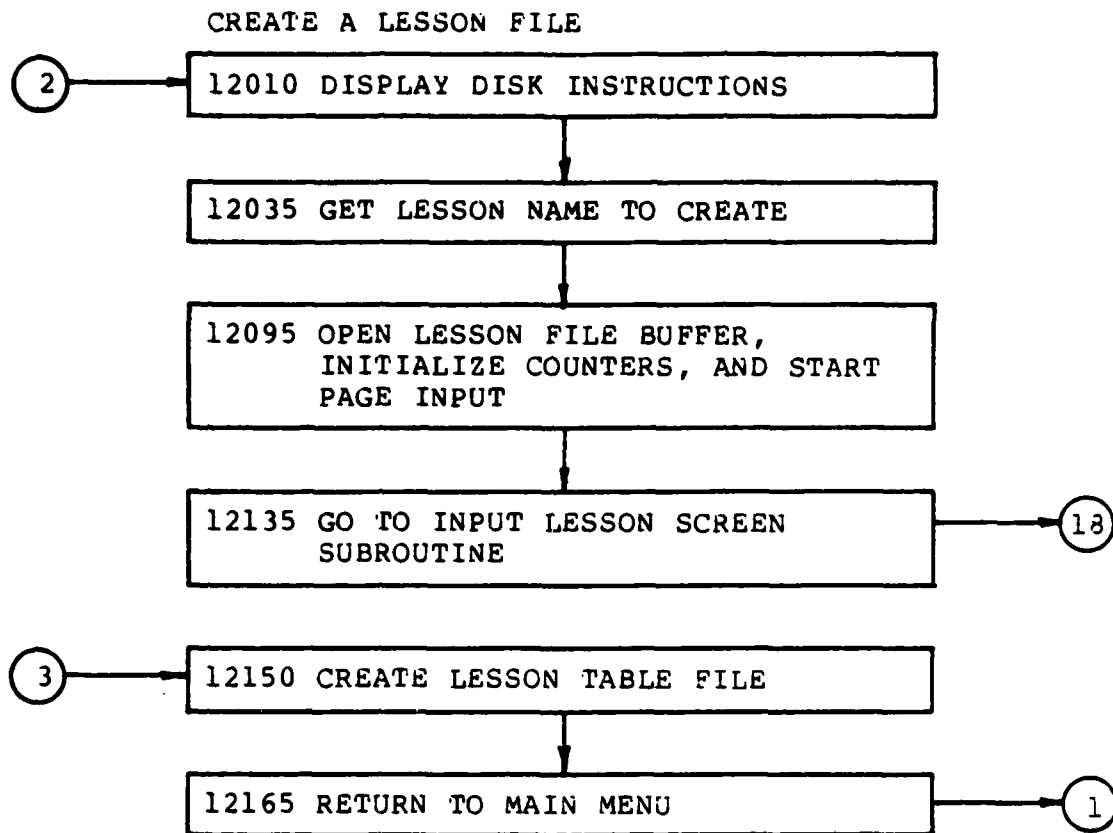

Figure D.1: WRITE/BAS Block Diagram (continued)

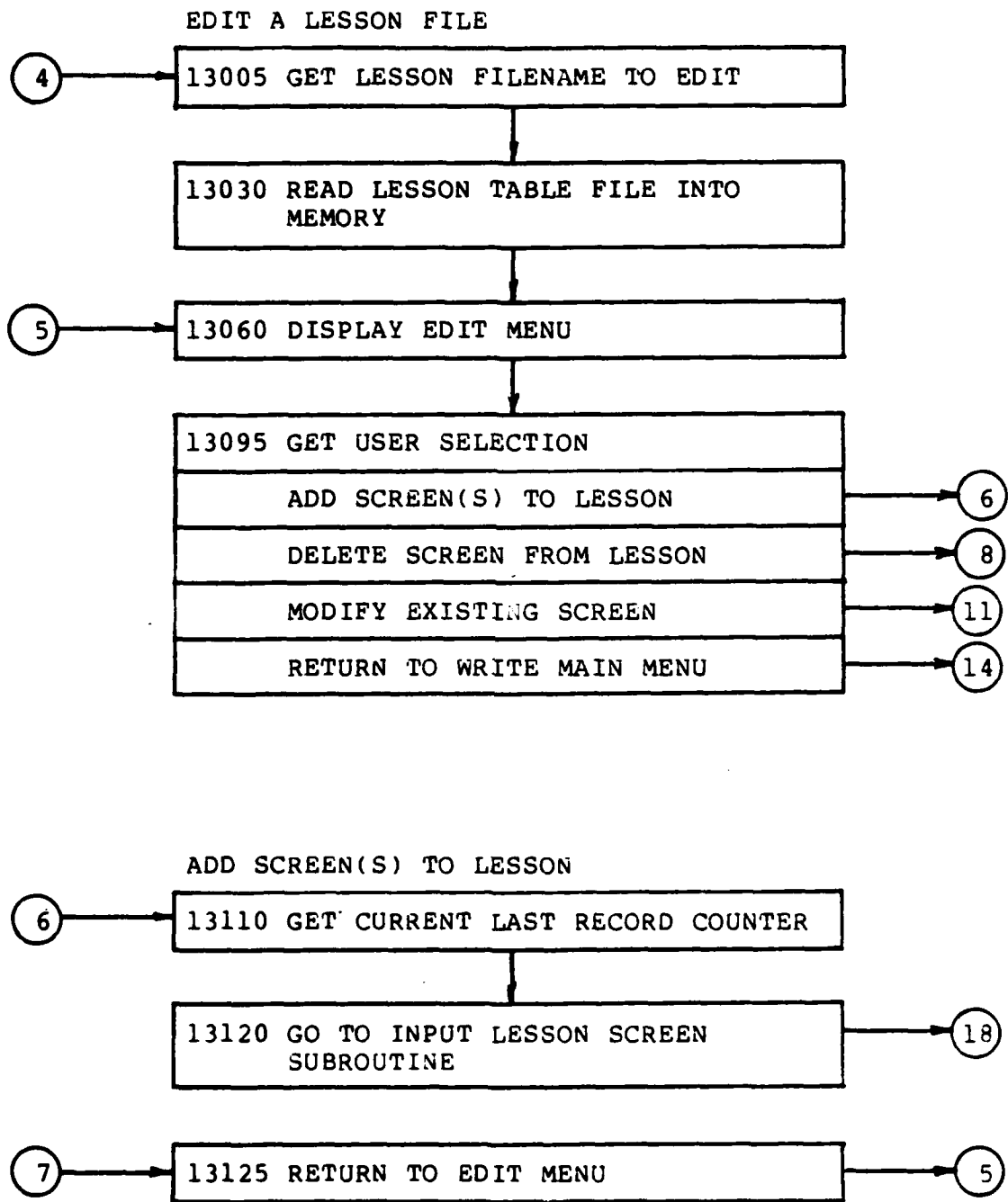

Figure D.1: WRITE/BAS Block Diagram (continued)

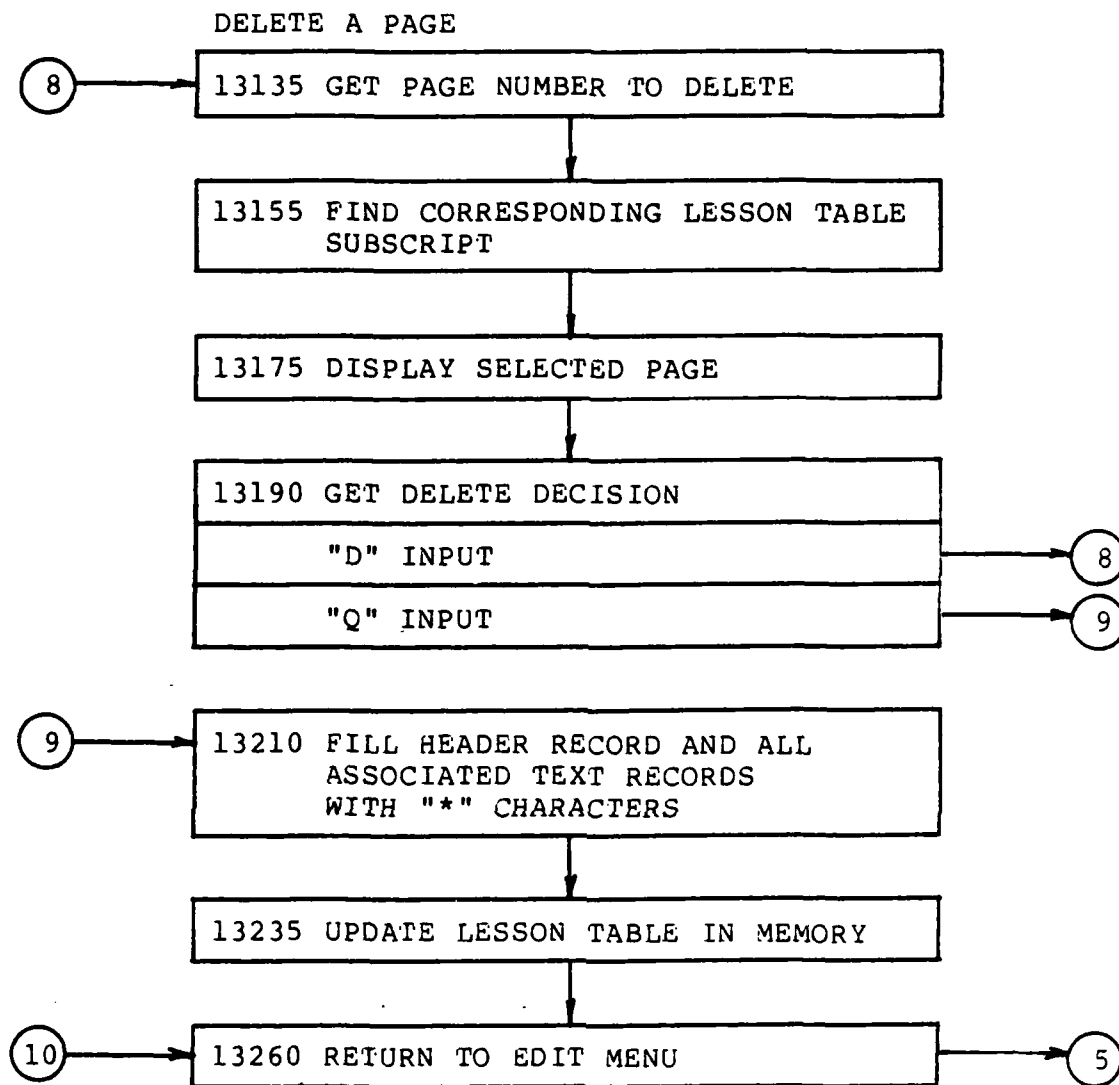

Figure D.1: WRITE/BAS Block Diagram (continued)

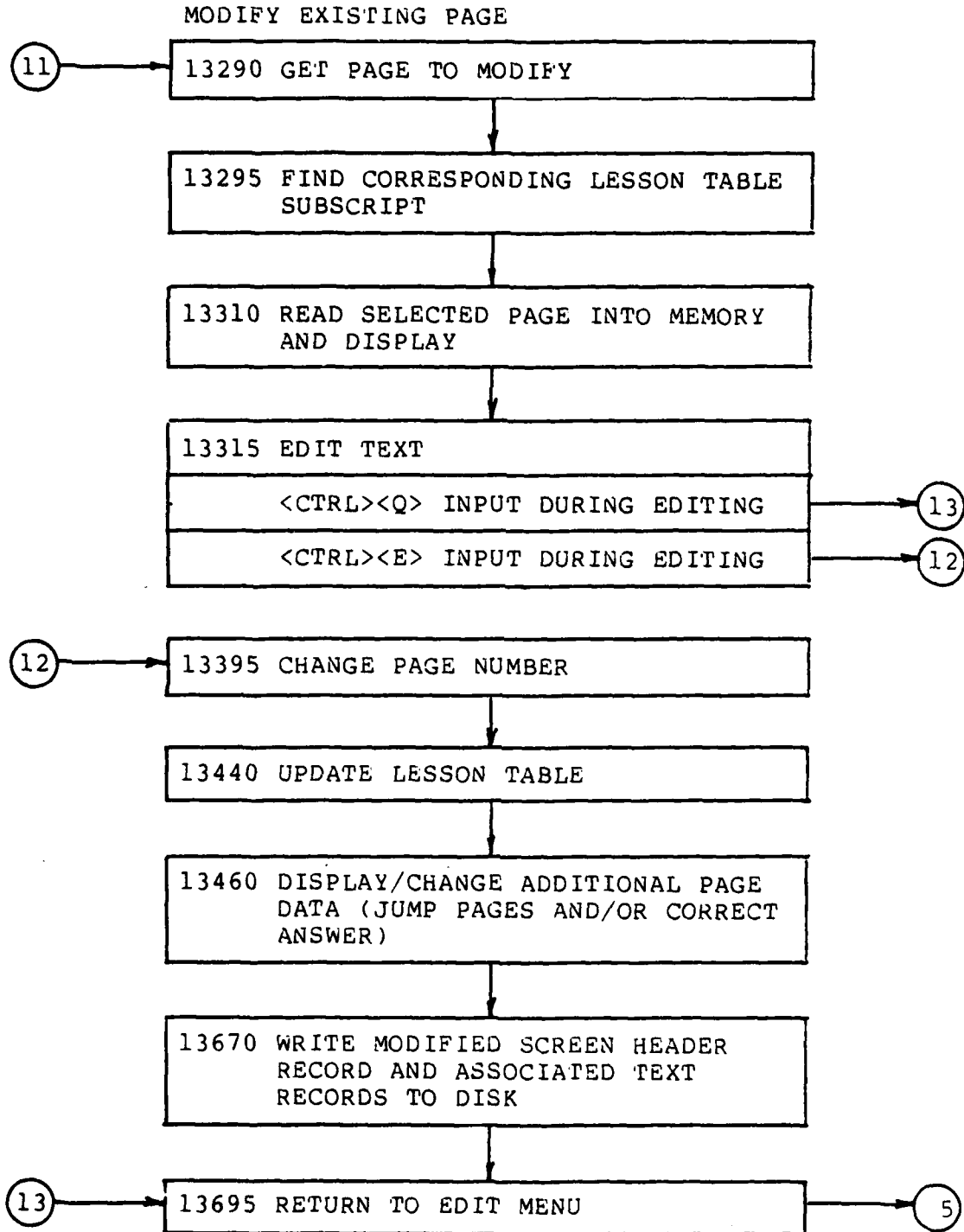

Figure D.1: WRITE/BAS Block Diagram (continued)

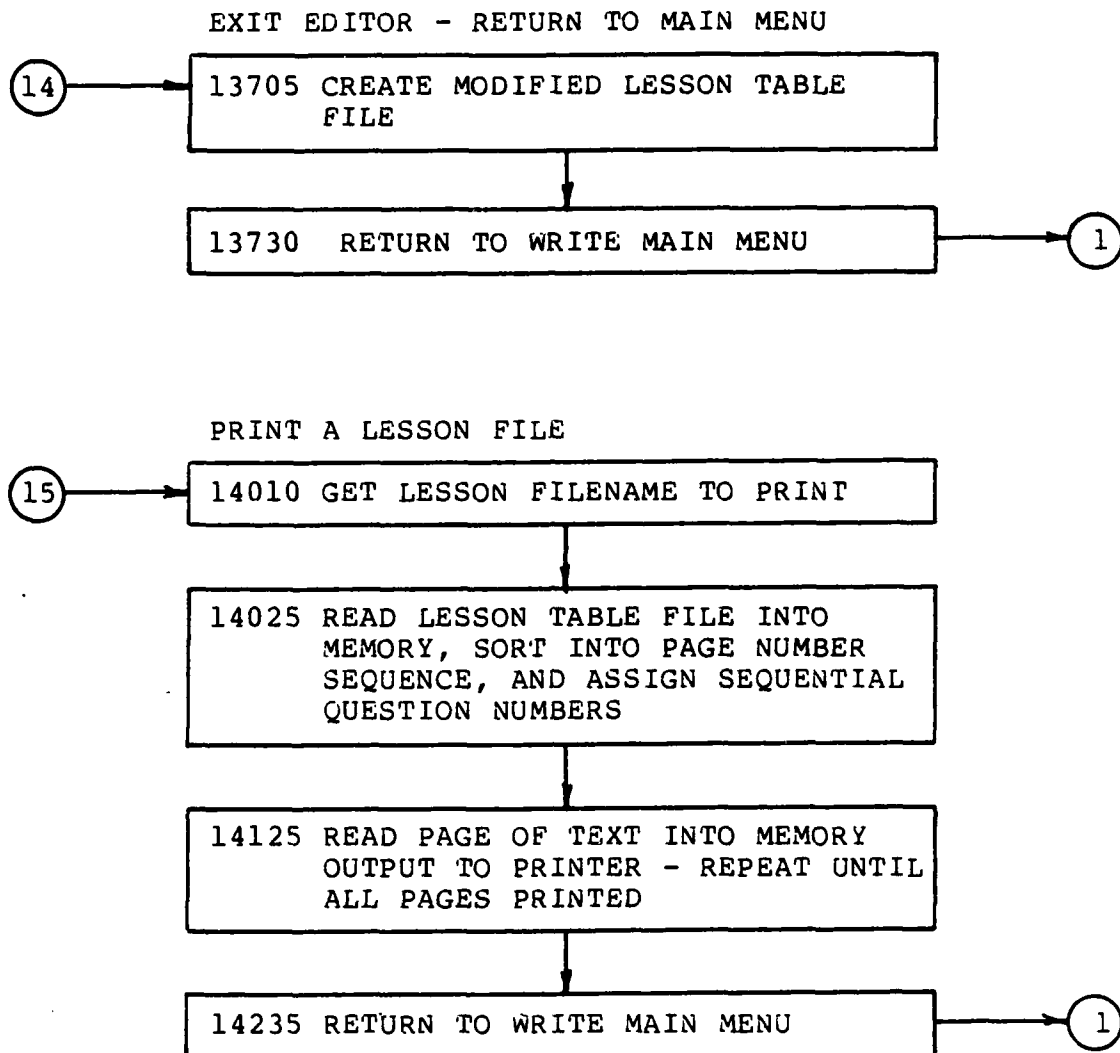

Figure D.1: WRITE/BAS Block Diagram (continued)

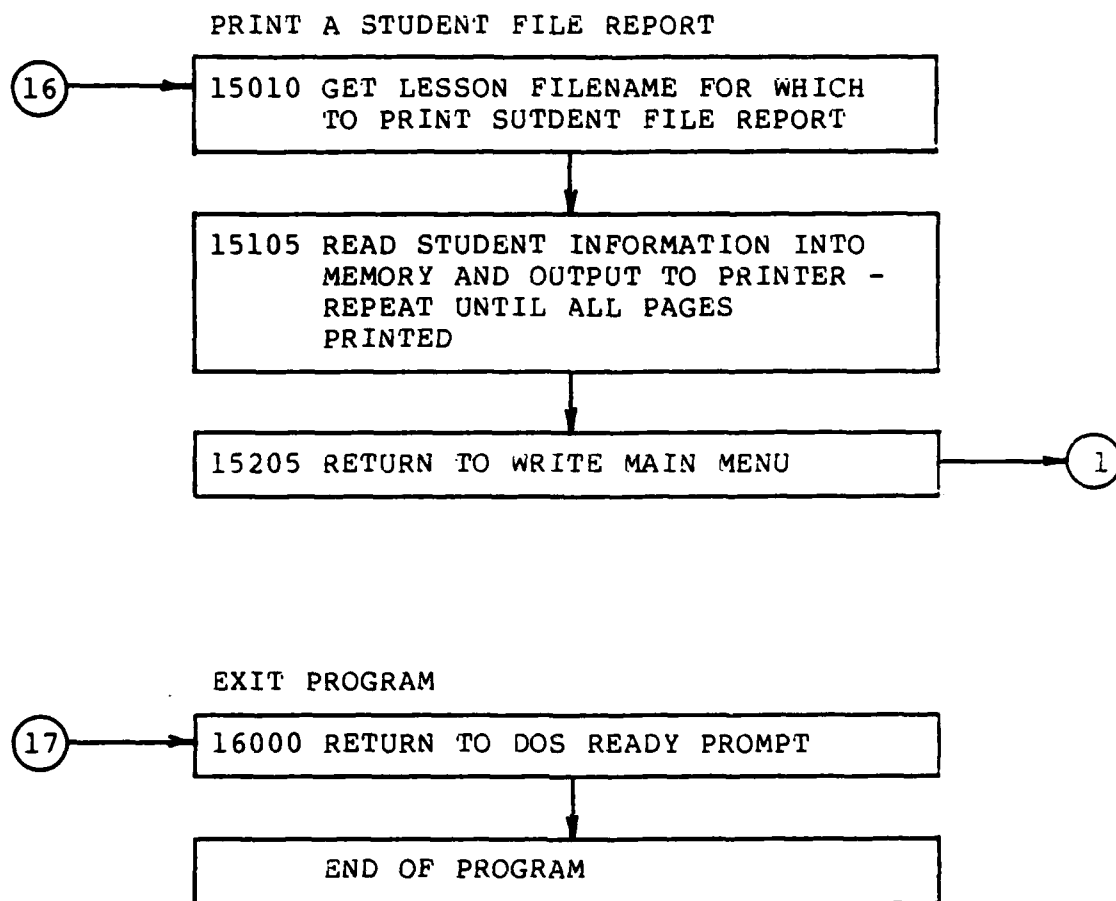

Figure D.1: WRITE/BAS Block Diagram (continued)

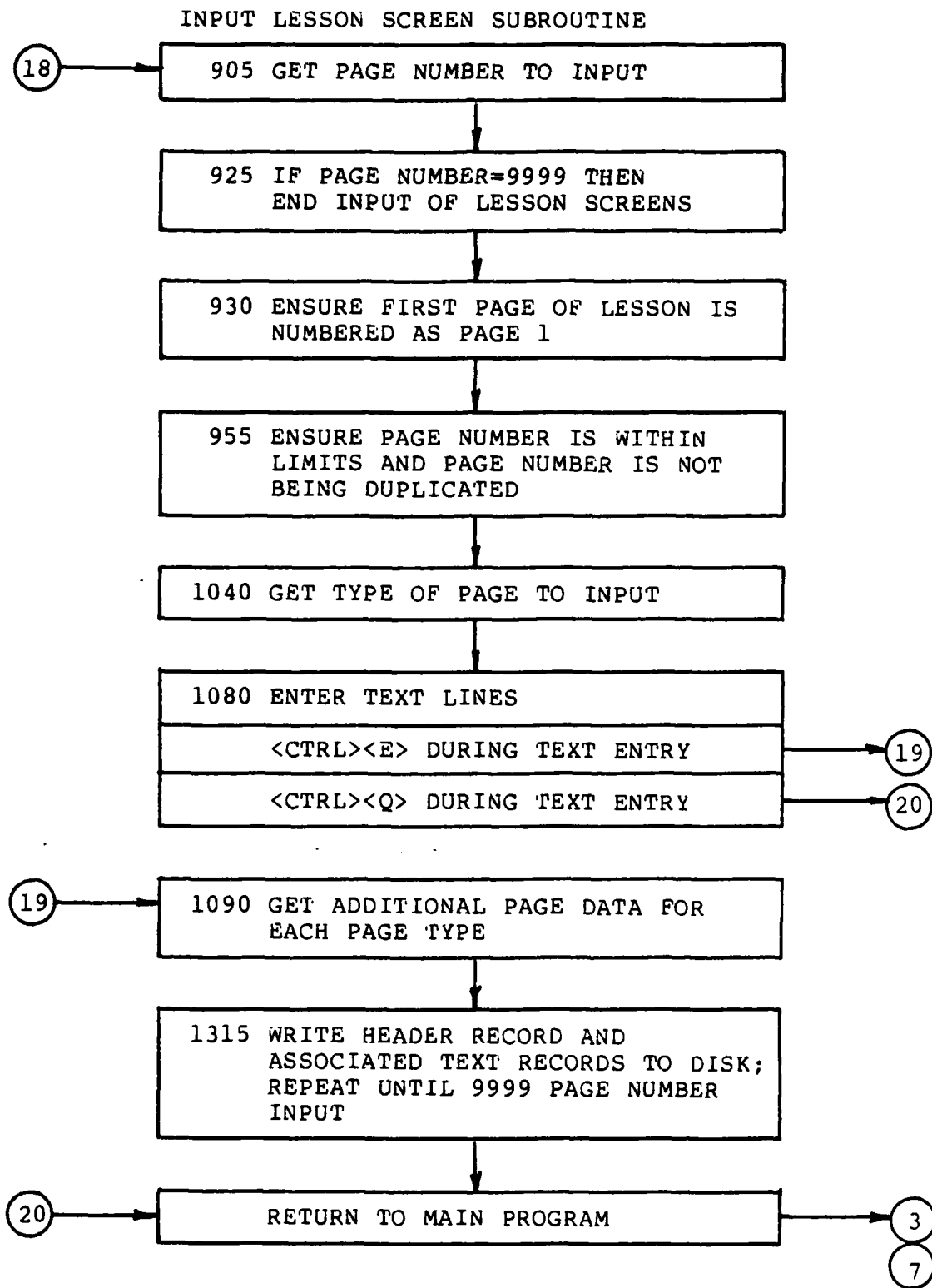

Figure D.1: WRITE/BAS Block Diagram (continued)

WRITE/BAS Variable List

A\$	String for user input from keyboard.
AJUMP%	Go to lesson page number for <A>/<T>/<ENTER> response.
AJUMP	Temporary input value for AJUMP%.
ANSWERS\$	Correct answer for question (A-E or T/F).
BJUMP%	Go to lesson page number for /<F> response.
BJUMP	Temporary input value for BJUMP%.
BUFi\$	Temporary buffer variable for use with direct access files (i=integer value).
CC%	Cursor column position counter.
CJUMP%	Go to lesson page number for <C> response.
CJUMP	Temporary input value for CJUMP%.
COUNT	Counter for determining file record numbers.
DASH\$	String of 80 dash characters.
DJUMP%	Go to lesson page number for <D> response.
DJUMP	Temporary input value for DJUMP%.
DUMMY\$	Dummy variable for reading unused portions of direct access files.
EJUMP%	Go to lesson page number for <E> response.
EJUMP	Temporary input value for EJUMP%.
ENTERS\$	"Press <ENTER>..." instruction line.
FLAG%	Flag variable returned from subroutines to identify specific disk errors.
I	FOR/NEXT loop counter.
J	FOR/NEXT loop counter.
LASTREC	Number of last record in a direct-access file.
LC%	Cursor row position counter.
LEGAL\$	String containing all allowable letter key inputs.
MCQPS	"Multiple Choice Question Page"
MORE%	Number of associated disk records required to generate lesson page in lesson text file.
MORE%(Number of associated disk records required to generate lesson page in lesson table array.
NEED\$	String containing codes for files required by program modules.
NUMPAGES%	Number of pages in lesson text file.
PAGE%	Lesson page number in lesson text file.

PAGE%(Lesson page number in lesson in lesson table array.
PAGE	Temporary input value for PAGE%.
PCT	Percentage of correct question responses.
PROMPT\$	"Press <letter> of your choice..." instruction line.
PTEST%	Temporary page number value for determining if page number is within legal limits.
QDATA\$	"Enter requested data and press <ENTER>..." instruction line.
QDATE\$	String containing date student performed lesson.
QEDIT\$	Text editor instruction line.
QINST\$	Instruction line to be displayed on lesson screen.
QMAT%	Array subscript in lesson table.
QNAME\$	Lesson name to be displayed on lesson screen.
QNUM%(Question number in lesson table.
QNUM%	Temporary counter for assigning question numbers.
QPAGE\$	Page number to be displayed on lesson screen.
QPAGE%	Lesson page number being displayed during lesson execution; active page number.
QTEST\$	File name for determining if file is on disk.
QTYPE\$	Page type to be displayed during lesson development.
RCOUNT%	Counter for number of correct responses entered.
REC	Record number for direct access file input/output.
STAR\$	String of 60 asterisk characters.
START%	Starting lesson text file record number in lesson text file.
START%(Starting lesson text file record number in lesson table.
STUDENT\$	Student's name (first initial and last name; no space).
STUFILES\$	Name of file for writing student lesson data.
TABLE\$	Name of file for lesson table.
TCOUNT%	Counter for total number of questions asked.
TEST\$	Temporary string for determining legal word-wrap position.
TEST%	Temporary value for determining legal word-wrap position.
TEXT\$	Name of disk file for lesson text.

TEXT\$(Array holding text lines for lesson page.
TFQP\$("True/False Question Page"
TNAME\$(Lesson name being used.
TP\$("Text Page"
TPOS	Temporary cursor column position.
TROW	Temporary cursor row position.
TYPE\$(Lesson page type indicator (#=text page; ?=question page).
TYPE\$(Lesson page type indicator in lesson table.
WCOUNT%	Counter for number of incorrect question responses.
WQUEST\$(Array to hold wrong question responses.
WQUEST%	Array to hold wrong question numbers.
WQUEST%\$(Array to hold wrong question numbers.
YN\$("<Y>es <N>o..." instruction line.

WRITE/BAS Record File Formats

WRITE/BAS produces three files for use by the LEARNER/BAS program and uses one file produced by the WRITE/BAS program. The following pages contain the record file formats for these files. Although sequential ASCII files are not formatted (data elements are variable length), lengths are provided for these data elements for reference purposes.

The first file produced by WRITE/BAS, <Lesson Name>/TXT is comprised of two different types of formatted, direct-access records which form a page "block". A header record containing information about the lesson page is followed by from one to twenty text records which contain the page text material.

The second file, <Lesson Name>/TAB, is a sequential ASCII file which contains certain information from the text header records. This file is loaded into memory permitting very rapid access of the proper text records.

The third file, <Lesson Name>/STU, is a sequential ASCII file which contains data generated during lesson use. This file is appended on completion of each execution of a lesson module. If the file does not exist then it is created by the LEARNER/BAS program.

File: <Lesson Name>/TXT (Header records)
 Type: Formatted, direct access

<u>Length</u>	<u>Variable/s</u>	<u>Type</u>	<u>Remarks</u>
1	TYPES\$ BUF1\$	A	Page type; # = text page, ? = question page, null/blank = text record, * = deleted record.
5	PAGE% BUF2\$	N	User defined page number; used for lesson branching/reference purposes.
5	AJUMP% BUF3\$	N	Branch to page for <A> response to multiple choice question, <T> response to true/false question, or <ENTER> key for text page.
5	BJUMP% BUF4\$	N	Branch to page for response to multiple choice question or <F> response to true/false question.
5	CJUMP% BUF5\$	N	Branch to page for <C> response to multiple choice question.
5	DJUMP% BUF6\$	N	Branch to page for <D> response to multiple choice question.
5	EJUMP% BUF7\$	N	Branch to page for <E> response to multiple choice question.
1	ANSWERS\$ BUF8\$	A	Correct response for question; must equal A-E or T/F.
3	MORE% BUF9\$	N	Number of additional records of page (i.e., number of text lines); must equal 1-20 (third character reserved by BASIC for sign).
46	DUMMYS\$		Not used in header records.

Total record length = 81

File: <Lesson Name>/TXT (text records)
Type: Formatted, direct access

<u>Length</u>	<u>Variable/s</u>	<u>Type</u>	<u>Remarks</u>
1	-	A	Null/blank=text record; *=deleted record.
80	TEXT\$	A/N	Text line.

Total record length = 81

File: <Lesson Name>/TAB
Type: Sequential ASCII

<u>Length</u>	<u>Variable/s</u>	<u>Type</u>	<u>Remarks</u>
5	PAGE% BUF2\$	N	User defined page number; used for lesson branching.
4	START%	N	Starting file record number for PAGE% header record in <Lesson Name>/TXT file.
4	MORE%	N	Number of text records in <Lesson Name>/TXT file comprising PAGE%.
1	TYPES\$	A	Page type

File: <Lesson Name>/STU
Type: Sequential ASCII

<u>Length</u>	<u>Variable/s</u>	<u>Type</u>	<u>Remarks</u>
NA	STUDENT\$	A	Student name (first initial and last name; no space).
NA	DATE\$	A/N	Variable length; format as returned by applicable BASIC/DOS.
4	TCOUNT%	N	Total questions asked during lesson (may differ from total questions in a lesson due to branching and/or repeated questions).
4	RCOUNT%	N	Number of correct responses.
4	WCOUNT%	N	Number of incorrect responses.
4	WQUEST%(i)	N	Question number answered incorrectly (i=1 to WCOUNT%).
1	WQUEST\$(i)	A	Incorrect response to question (i=1 to WCOUNT).

WRITE/BAS BASIC Variables Cross-Reference List

A\$	155	160	165	170	175	200	205
	210	260	265	270	305	320	340
	340	375	395	415	415	420	425
	455	455	460	505	545	545	550
	1060	1065	1070	1160	1160	1265	1265
	11085	11085	11085	11085	11085	13100	13100
	13100	13100	13205	13335	13340	13345	13350
	13355	13360	13365	13370	13375	13380	13380
	13380	13380	13415	13500	13530	13535	13535
	13555	13565	13570	13575	13580	13585	13615
	13620	13620	13640	13655	13660	17045	17045
AJUMP%	830	1135	1135	1170	1170	1275	1275
	1335	13490	13500	13545	13565	13630	13655
	13675	14185	14190	14195			
AJUMP	1135	1135	1135	1170	1170	1170	1275
	1275	1275	13500	13500	13500	13500	13565
	13565	13565	13565	13655	13655	13655	13655
ANSWERS\$	855	1160	1265	1360	13465	13465	13520
	13535	13605	13620	13675	14190	14190	14195
	14195						
BASE	10025						
BJUMP%	835	1185	1185	1290	1290	1340	13545
	13570	13630	13660	13675	14190	14195	
BJUMP	1185	1185	1185	1290	1290	1290	13570
	13570	13570	13570	13660	13660	13660	13660
BUF	570	570	570	570	570	570	570
	570	570	595	595	605	615	620
	825	830	835	840	845	850	855
	860	875	880	1325	1330	1335	1340
	1345	1350	1355	1360	1365	1405	1410
	12115	12115	12115	12115	12115	12115	12115
	12115	12115	12120	12120	13045	13045	13045
	13045	13045	13045	13045	13045	13045	13050
	13050	13215	13220	13675	13675	13675	13675
	13675	13675	13675	13675	13675	13690	13690
	14110	14110	14110	14110	14110	14110	14110
	14110	14110	14115	14115			
CC%	250	255	275	280	310	315	325
	325	345	355	355	380	430	430
	435	470	525				

CJUMP%	840	1200	1200	1345	13545	13575	13675
	14195						
CJUMP	1200	1200	1200	13575	13575	13575	13575
COUNT	575	600	600	605	610	615	620
	640						
DASH\$	130	135	10030	14140	14215	15060	15070
	15190						
DJUMP%	845	1215	1215	1350	13545	13580	13675
	14195						
DJUMP	1215	1215	1215	13580	13580	13580	13580
DUMMY\$	570	875	1370	12115	13045	13675	14110
EJUMP%	850	1230	1230	1355	13545	13585	13675
	14195						
EJUMP	1230	1230	1230	13585	13585	13585	13585
ENTER\$	940	965	1010	1475	1595	10065	12015
	12185	13165	13305	13450	14075	15020	
FLAG%	230	230	1140	1175	1190	1205	1220
	1235	1280	1295				
I	585	590	625	640	645	645	645
	645	650	690	700	700	700	700
	705	705	720	730	730	740	745
	750	755	760	770	790	795	795
	800	865	870	880	885	985	990
	995	1155	1155	1155	1260	1260	1260
	1395	1410	1420	1520	1525	1530	1535
	1655	1660	1665	12060	12065	12070	12075
	13240	13245	13245	13245	13245	13245	13245
	13245	13245	13245	13400	13400	13400	13435
	13435	13435	13690	13690	13690	14045	14050
	14055	14065	15125	15130	15130	15135	15140
	15155	15155	15155	15165	17015	17015	17015
	17015						
J	735	740	745	750	755	760	765
	14165	14170	14175	15150	15155	15155	15155
	15160						
LASTREC	580	585					

LC%	250	255	275	275	285	285	290
	315	315	350	350	380	380	425
	425	450	465	465	470	470	475
	495	505	505	510	510	515	520
	520	530	530	550	1320		
LEGAL\$	165	1055	1160	1265	11080	13095	13200
	13410	13495	13525	13535	13550	13560	13610
	13620	13635	13645				
MCQP\$	1065	10050					
MORE%	860	865	1320	1365	1395	1440	12165
	13360	13380	13675	13690	13710	14165	14230
	17050						
MORE%(615	645	700	755	755	1440	1655
	12165	13005	13210	13245	13245	14005	
NEED\$	1570	1575	1580	13015	14020	15010	
NUMPAGES%	720	730	735	790	985	1000	1000
	1440	1440	1440	1440	11030	13240	13250
	13250	13435	14045	14130			
PAGE%	920	925	925	935	960	960	970
	990	1015	1035	1075	1330	1440	12165
	13150	13160	13180	13290	13300	13320	13405
	13440	13440	13675	13710	14230	17050	
PAGE%(620	645	700	740	740	745	745
	795	990	1440	12005	13005	13245	13245
	13435	13440	14005	14150			
PAGE	920	920	920	13150	13150	13150	13290
	13290	13290	13430	13430	13435	13440	13445
PCT	15110	15115					
PROMPT\$	1035	10035	11045	13065	13535	13560	13620
	13645						
PTEST%	230	230	1135	1170	1185	1200	1215
	1230	1275	1290				
QDATA\$	910	1095	1500	10040	12040	13140	13280
	13420	13500					
QDATE\$	15105	15115					
QEDIT\$	1075	10045					

QINST\$	135	675	910	940	965	1010	1035
	1075	1475	1500	1595	11045	12015	12040
	12155	12185	13065	13140	13180	13280	13320
	13705	14075	15020				
QMAT%	795	805	820	870	1655	13165	13210
	13210	13210	13240	13305	13440	13680	14130
	14150	14155	14155	14185	14190	14195	14210
QNAME\$	130	675	910	940	965	1010	1035
	1075	1595	11045	12015	12040	12155	12185
	13005	13065	13140	13180	13280	13320	13705
	14015	14075	15005	15020			
QNUM% (14055	14155					
QNUM%	14040	14055	14060	14060			
QPAGES\$	130	675	910	940	965	1010	1035
	1075	1475	1500	1595	11045	12015	12040
	12155	12185	13065	13140	13180	13280	13320
	13705	14075	15020				
QPAGE%	795	13160	13300				
QTEST\$	1570	1570	1575	1575	1580	1580	1600
QTYPE\$	130	675	910	940	965	1010	1035
	1060	1065	1070	1475	1500	11045	12015
	12040	12155	12185	13065	13140	13180	13280
	13320	13705	14075	15020			
RCOUNT%	15105	15110	15115				
REC	935	935	1375	1380	1400	1400	1415
	1425	1425	12130	13115	13210	13225	13230
	13680	13685	13690	13690	13690		
STAR\$	17005	17015	17015				
START%	1375	1440	12165	13710	14230	17050	
START% (610	645	700	750	750	820	870
	1440	12005	13005	13210	13210	13245	13245
	13680	14005					
STUDENT\$	15105	15115					
STUFILE\$	1560	1580	15090				
TABLE\$	635	685	1555	1575	12085		

TCOUNT%	15105	15110	15115				
TEST\$	495	500					
TEST%	170	175	175	175	490	495	500
	500	505	510	515	515	525	1525
	1530	1530	1530	12065	12070	12070	12070
TEXT\$	400	565	1450	1550	1570	12080	12110
	12165	13040	13205	13255	13345	13695	13710
	14105	14205	14230	17050			
TEXT\$(275	275	315	315	350	350	380
	380	425	425	465	465	495	505
	505	510	510	520	880	1410	1450
	1660	12005	13005	13205	13255	13345	13375
	13375	13375	13375	13380	13690	13695	14005
	14170	14205					
TFQP\$	1070	10060					
TNAME\$	675	910	940	965	1010	1035	1075
	1510	1515	1520	1525	1530	1550	1555
	1560	1610	12050	12055	12060	12065	12070
	12080	12085	12155	12195	13065	13140	13180
	13280	13320	14075	15020	15050		
TP\$	1060	10055					
TPOS	13375	13375	13375	13375			
TROW	13375	13375	13375	13375	13375	13375	13375
TYPE\$	825	1060	1065	1070	1100	1105	1110
	1240	1300	1325	1440	12165	13465	13465
	13470	13475	13480	13640	13675	13710	14230
	17050						
TYPE\$(605	645	700	760	760	1440	12005
	13005	13245	13245	14005	14050	14155	14185
	14190	14195					
WCOUNT%	15105	15115	15120	15125	15140		
WQUEST\$(15095	15130	15155				
WQUEST\$	15175	15200					
WQUEST%	15175	15200					
WQUEST\$(15095	15130	15155	15155			

YNS

10070 13405 13495 13525 13550 13610 13635

WRITE/BAS Line Number Cross-Reference List

125 =>	675	910	940	965	1010	1035	1075
	1475	1500	1595	11045	12015	12040	12155
	12185	13065	13140	13180	13280	13320	13705
	14075	15020					
150 =>	1055	1160	1265	11080	13095	13200	13410
	13495	13525	13535	13550	13560	13610	13620
	13635	13645					
155 =>	165						
195 =>	210	950	975	1020	1490	1630	12025
	12205	13165	13305	13450	14090	15035	
225 =>	1135	1170	1185	1200	1215	1230	1275
	1290						
245 =>	1080						
255 =>	295	310	330	345	365	415	440
	480	535					
260 =>	265						
305 =>	270						
340 =>	305						
375 =>	340	550					
395 =>	375						
415 =>	395						
450 =>	435						
455 =>	455						
490 =>	460						
495 =>	500						
540 =>	290	450	475				
545 =>	545	550					
560 =>	12160	13715					
625 =>	595						
670 =>	13035	14030					
695 =>	710						
715 =>	695						
765 =>	740						
785 =>	13160	13300					
815 =>	13170	13310	14135				
900 =>	12135	13120					
905 =>	950	975	1020	1455			
915 =>	920						
955 =>	935						
980 =>	960						
1010 =>	990						
1030 =>	1005						
1115 =>	1100						
1120 =>	1140						
1130 =>	1135						
1150 =>	1105						
1165 =>	1170	1175					
1180 =>	1185	1190					
1195 =>	1200	1205					
1210 =>	1215	1220					

1225 =>	1230	1235					
1255 =>	1110						
1270 =>	1275	1280					
1285 =>	1290	1295					
1315 =>	1145	1245	1305				
1465 =>	13020	14025	15010				
1500 =>	1635						
1590 =>	1565						
1620 =>	1600	1605	1610				
1625 =>	1620						
1650 =>	13185	13325					
10000 =>	10						
11000 =>	1515	12055	17055				
11025 =>	12170	13730	14235	15205			
12000 =>	11085						
12015 =>	12215						
12180 =>	12105						
12205 =>	12190	12195					
12215 =>	12210						
13000 =>	11085						
13060 =>	13125	13165	13205	13260	13305	13345	13695
13105 =>	13100						
13130 =>	13100						
13145 =>	13150						
13270 =>	13100						
13285 =>	13290						
13335 =>	13340	13355	13355	13360	13360	13365	13365
	13370	13370	13375	13380	13385		
13390 =>	13350						
13405 =>	13440	13455					
13425 =>	13430						
13445 =>	13435						
13460 =>	13415						
13485 =>	13470	13505					
13500 =>	13500						
13510 =>	13475						
13520 =>	13535						
13540 =>	13530	13590					
13565 =>	13565						
13570 =>	13570						
13575 =>	13575						
13580 =>	13580						
13585 =>	13585						
13595 =>	13480						
13600 =>	13620						
13625 =>	13615						
13630 =>	13665						
13655 =>	13655						
13660 =>	13660						
13670 =>	13500	13555	13640				
13700 =>	13100						
14000 =>	11085						
14065 =>	14050						

14200 => 14185 14190
15000 => 11085
15095 => 15180
15170 => 15120
15185 => 15100
16000 => 11085
17000 => 1515 1585 1640 10025 12125 12215
17045 => 17045

WRITE/BAS BASIC Keywords Cross-Reference List

*	15110						
+	255	285	350	355	425	430	470
	505	505	515				
	520	520	530	600	675	705	735
	870	1000	1400				
	1425	1550	1555	1560	10035	10040	10045
	10045	10045	10045	10045	10055	10060	10065
	10070	12080	12085	12155	13115	13180	13180
	13180	13210	13245	13245	13245	13245	13360
	13360	13375	13375	13380	13690	13705	14060
	15155	15155	15155	17005			
-	175	255	275	315	325	380	500
	505	525	720	730	805	1530	12070
	13165	13250	13305	13355	13355	13360	13365
	13375	13375	13375	13375	13375	13375	13375
	13380						
/	15110						
<	175	210	230	270	305	340	340
	375	395	415	460	515	550	960
	1530	1570	1575	1580	12070	13380	13415
	13500	13500	13530	13555	13565	13570	13575
	13580	13585	13615	13640	13655	13660	14050
	14190	14195	15155	17045			
=	155	160	165	170	175	175	175
	200	205	230	230	250	250	260
	265	275	280	285	290	310	315
	325	350	355	380	425	430	435
	450	455	455	465	470	470	475
	490	495	500	500	505	510	525
	530	545	545	575	580	585	595
	595	600	605	610	615	620	640
	675	675	675	675	690	705	720
	730	735	790	795	795	805	825
	830	835	840	845	850	855	860
	865	875	880	910	910	910	910
	920	925	925	935	935	940	940
	940	940	960	960	965	965	965
	965	985	990	1000	1010	1010	1010
	1010	1035	1035	1035	1035	1055	1060
	1060	1060	1065	1065	1065	1070	1070
	1070	1075	1075	1075	1100	1105	1110
	1135	1135	1140	1155	1160	1160	1170
	1170	1175	1185	1185	1190	1200	1200
	1205	1215	1215	1220	1230	1230	1235
	1240	1260	1265	1265	1275	1275	1280
	1290	1290	1295	1300	1320	1325	1330
	1335	1340	1345	1350	1355	1360	1365
	1370	1375	1395	1400	1405	1410	1425
	1440	1440	1440	1440	1475	1475	1475
	1500	1500	1500	1515	1520	1525	1530

=	1530	1530	1550	1555	1560	1570	1575
	1580	1595	1595	1595	1600	1605	1610
	1655	10030	10035	10040	10045	10050	10055
	10060	10065	10070	11030	11045	11045	11045
	11045	11080	11085	11085	11085	11085	11085
	12015	12015	12015	12015	12040	12040	12040
	12040	12055	12060	12065	12070	12070	12070
	12080	12085	12130	12155	12155	12155	12155
	12185	12185	12185	12185	12190	12195	13005
	13020	13065	13065	13065	13065	13095	13100
	13100	13100	13100	13115	13140	13140	13140
	13140	13150	13160	13165	13180	13180	13180
	13180	13200	13205	13210	13215	13220	13240
	13245	13245	13245	13245	13250	13280	13280
	13280	13280	13290	13300	13305	13320	13320
	13320	13320	13335	13340	13345	13350	13355
	13355	13360	13360	13365	13365	13370	13370
	13375	13375	13375	13375	13380	13380	13380
	13380	13380	13400	13410	13435	13435	13440
	13440	13465	13465	13465	13465	13470	13475
	13480	13495	13500	13525	13535	13535	13550
	13560	13565	13565	13570	13570	13575	13575
	13580	13580	13585	13585	13610	13620	13620
	13635	13640	13645	13655	13655	13660	13660
	13675	13675	13675	13675	13675	13675	13675
	13675	13675	13675	13680	13690	13690	13690
	13690	13705	13705	13705	13705	14015	14020
	14040	14045	14055	14060	14075	14075	14075
	14075	14130	14155	14165	14185	14190	14195
	15005	15010	15020	15020	15020	15020	15110
	15120	15125	15140	15150	17005	17015	17045
>	175	210	230	270	290	305	340
	340	345	375	395	415	460	550
	740	920	935	960	1135	1170	1185
	1200	1215	1230	1275	1290	1530	1570
	1575	1580	12070	13150	13290	13380	13415
	13430	13500	13500	13530	13555	13565	13570
	13575	13580	13585	13615	13640	13655	13660
	14050	14190	14195	15155	17045		
AND	175	340	935	960	1530	12070	13380
	13380	13465	13500	13565	13570	13575	13580
	13585	13655	13660	14190	14195		
ASC	170	375	395	415	415	550	1525
	12065	13345	13350	13355	13360	13365	13370
	13375	13380	13380				
CHR\$	160	175	205	210	270	295	305
	340	340	460	515	540	915	1095
	1120	1125	1130	1155	1165	1180	1195
	1210	1225	1260	1270	1285	1530	12070
	13145	13165	13285	13305	13375	13380	13400
	13405	13405	13420	13425	13445	13450	13490
	13495	13500	13500	13520	13525	13535	13535
	13560	13560	13565	13570	13575	13580	13585

CHRS	13605	13610	13620	13620	13630	13645	13650
	13655	13660	14220	15195	17045		
CLOSE	630	655	715	1515	1570	1575	1580
	1585	1640	12140	12165	12215	13040	13710
	13720	14225	15205	17055			
CLS	130	12170	14235	15205	16010	17010	
DATES	15050						
DIM	1450	12005	13005	13205	13255	13345	13695
	14005	14205	15095				
ELSE	230	500	550	740	920	1135	1170
	1185	1200	1215	1230	1275	1290	11085
	11085	11085	11085	13100	13100	13100	13150
	13290	13355	13360	13365	13370	13435	13500
	13500	13565	13570	13575	13580	13585	13655
	13660	14155					
END	160	205	16010	17060			
EOF	695	15100					
ERASE	400	1450	12165	13205	13255	13345	13695
	13725	14205	14230	15175	15200	17050	
ERL	17025						
ERR	1600	1605	1610	12190	12195	17025	
ERROR	1515	1565	1585	1640	10025	12105	12125
	12215						
FIELD	570	12115	12120	13045	13050	14110	14115
FOR	585	640	730	735	790	865	985
	1155	1260	1395	1520	1655	12060	13210
	13240	13400	13435	13690	14045	14130	14165
	15125	15140	15150	17015			
GET	590	820	870				
GOSUB	675	910	940	950	965	975	1010
	1020	1035	1055	1075	1080	1135	1160
	1170	1185	1200	1215	1230	1265	1275
	1290	1475	1490	1500	1595	1630	11045
	11080	12015	12025	12040	12135	12155	12160
	12185	12205	13020	13035	13065	13095	13120
	13140	13160	13165	13170	13180	13185	13200
	13280	13300	13305	13310	13320	13325	13410
	13450	13495	13525	13535	13550	13560	13610
	13620	13635	13645	13705	13715	14025	14030
	14075	14090	14135	15010	15020	15035	
GOTO	10	295	330	365	440	480	500
	535	710	950	975	1005	1020	1145
	1245	1305	1455	1515	1515	1565	1585
	1600	1605	1610	1635	1640	10025	12055
	12105	12125	12170	12190	12195	12215	12215
	13125	13165	13205	13260	13305	13345	13350
	13355	13360	13365	13370	13375	13380	13385
	13440	13455	13500	13505	13535	13565	13570
	13575	13580	13585	13590	13620	13640	13655
	13660	13665	13695	13730	14185	14190	14235
	15120	15180	15205				
IF	160	165	175	205	210	230	265
	270	290	305	310	340	345	375

IF	395	415	435	450	455	460	475
	500	515	545	550	595	695	740
	795	920	925	935	960	990	1060
	1065	1070	1100	1105	1110	1135	1140
	1170	1175	1185	1190	1200	1205	1215
	1220	1230	1235	1275	1280	1290	1295
	1515	1530	1570	1575	1580	1600	1605
	1610	11085	11085	11085	11085	11085	12055
	12070	12190	12195	13100	13100	13100	13100
	13150	13165	13205	13290	13305	13340	13345
	13350	13355	13355	13360	13360	13365	13365
	13370	13370	13375	13380	13380	13415	13430
	13435	13465	13470	13475	13480	13500	13500
	13530	13555	13565	13565	13570	13570	13575
	13575	13580	13580	13585	13585	13615	13640
	13655	13655	13660	13660	14050	14155	14185
	14190	14195	15100	15120	15155	17045	
INKEY\$	260	455	545	13335	17045		
INPUT	155	200	700	920	1135	1170	1185
	1200	1215	1230	1275	1290	1510	12050
	13150	13290	13430	13500	13565	13570	13575
	13580	13585	13655	13660	15105	15130	
INSTR	165	500	1570	1575	1580	14190	14195
LEFT\$	275	315	380	465	510	13375	
LEN	1520	12060					
LOC	610						
LOF	580	13115					
LPRINT	14140	14145	14150	14155	14155	14160	14170
	14180	14185	14190	14195	14200	14215	14220
	15050	15055	15060	15065	15070	15075	15115
	15145	15155	15170	15170	15190	15195	
LSET	1325	1330	1335	1340	1345	1350	1355
	1360	1365	1370	1405	1410	13215	13220
	13675	13675	13675	13675	13675	13675	13675
	13675	13675	13675	13690	13690		
MID\$	495	1525	1530	12065	12070	13380	
NEXT	625	650	765	770	800	885	995
	1155	1260	1420	1535	1665	12075	13230
	13245	13400	13435	13690	14065	14175	14210
	15135	15160	15165	17015			
ON	1515	1565	1585	1640	10025	12105	12125
	12215						
OPEN	565	635	685	1570	1575	1580	12110
	13040	14105	15090				
OPTION	10025						
OR	230	415	595	925	935	13465	
POS	13355	13360	13365	13365	13370	13370	13375
	13380	13380					
PRINT	130	130	130	130	135	135	135
	255	295	320	360	420	515	520
	540	540	680	915	945	950	970
	975	1015	1020	1040	1045	1050	1055
	1095	1120	1125	1130	1155	1160	1160

PRINT	1165	1180	1795	1210	1225	1260	1265
	1265	1270	1285	1480	1485	1505	1505
	1600	1605	1610	1615	1625	1660	11050
	11055	11060	11065	11070	11075	12020	12025
	12045	12045	12190	12195	12200	12205	13070
	13075	13080	13085	13090	13145	13165	13165
	13165	13195	13285	13305	13305	13305	13330
	13355	13360	13365	13370	13375	13375	13380
	13380	13400	13405	13405	13405	13420	13425
	13445	13450	13450	13490	13495	13495	13500
	13500	13520	13525	13525	13535	13535	13535
	13545	13550	13550	13560	13560	13560	13560
	13565	13570	13575	13580	13585	13605	13610
	13610	13620	13620	13620	13620	13630	13635
	13635	13645	13645	13645	13650	13655	13660
	14080	14085	15025	15030	17015	17015	17015
	17015	17020	17025	17030	17035	17040	
PUT	1380	1415	13225	13685	13690		
REM	1	2	3	4	5	6	7
	8	10	15	100	105	110	115
	120	125	145	150	185	190	195
	220	225	240	245	260	270	300
	305	335	340	345	370	375	390
	395	410	415	445	460	485	555
	560	665	670	725	780	785	810
	815	895	900	905	930	955	980
	1025	1030	1085	1090	1115	1150	1250
	1255	1310	1315	1385	1390	1430	1435
	1445	1460	1465	1470	1495	1540	1545
	1590	1645	1650	1675	10000	10005	10010
	10015	10020	10075	11000	11005	11010	11015
	11020	11025	11035	11040	11090	12000	12010
	12030	12035	12090	12095	12100	12145	12150
	12170	12175	12180	13000	13010	13025	13030
	13055	13060	13105	13110	13130	13135	13155
	13175	13190	13235	13265	13270	13275	13295
	13315	13345	13350	13355	13360	13365	13370
	13375	13380	13385	13390	13395	13460	13485
	13510	13515	13540	13595	13600	13625	13670
	13700	13735	14000	14010	14035	14070	14095
	14100	14120	14125	14235	14240	15000	15015
	15040	15045	15080	15085	15185	15205	15210
	16000	16005	17000				
RESUME	1620	12210	17055				
RETURN	140	180	215	235	385	405	550
	660	775	795	805	890	925	1585
	1640	1670					
RIGHT\$	505	13375					
ROW	13355	13355	13360	13360	13365	13370	13375
	13380	13380					
STEP	15140						

STR\$	1035	1075	1330	1335	1340	1345	1350
	1355	1365	13180	13320	13675	13675	13675
	13675	13675	13675	13675			
STRING\$	350	360	675	10030	10035	10040	10045
	10045	10045	10055	10060	10065	10070	12155
	13180	13180	13220	13630	13705	15050	17005
	17005						
SWAP	745	750	755	760			
TAB(14190	14195	15050	15145			
THEN	160	165	175	205	210	230	265
	270	290	305	310	340	345	375
	395	415	435	450	455	460	475
	500	515	545	550	595	695	740
	795	920	925	935	960	990	1060
	1065	1070	1100	1105	1110	1135	1140
	1170	1175	1185	1190	1200	1205	1215
	1220	1230	1235	1275	1280	1290	1295
	1515	1530	1570	1575	1580	1600	1605
	1610	11085	11085	11085	11085	11085	12055
	12070	12190	12195	13100	13100	13100	13100
	13150	13165	13205	13290	13305	13340	13345
	13350	13355	13355	13360	13360	13365	13365
	13370	13370	13375	13380	13380	13415	13430
	13435	13465	13470	13475	13480	13500	13500
	13530	13555	13565	13565	13570	13570	13575
	13575	13580	13580	13585	13585	13615	13640
	13655	13655	13660	13660	14050	14155	14185
	14190	14195	15100	15155	17045		
TO	585	640	730	735	790	865	985
	1155	1260	1395	1520	1655	12060	13210
	13240	13400	13435	13690	14045	14130	14165
	15125	15140	15150	17015			
USING	15115	15155					
VAL	615	620	830	835	840	845	850
	860						
WRITE	645						

WRITE/BAS Program Listing (TRSDOS Version)

```
1 '*****
2 '* WRITE/BAS - COMPUTER-ASSISTED INSTRUCTION SOFTWARE *
3 '* ROBERT MASON, LT, SC, USN *
4 '* AIR FORCE INSTITUTE OF TECHNOLOGY *
5 '* SCHOOL OF SYSTEMS AND LOGISTICS *
6 '* MAY 1987 *
7 '* TANDY/RADIO SHACK MODEL IV VERSION 01.00.00 *
8 '*****
9 '
10 GOTO 10000 ' JUMP TO START OF MAIN PROGRAM
15 '
100 '*****
105 '* SUBROUTINES *
110 '* (LINES 100-9999) *
115 '*****
120 '
125 ' SUBROUTINE - PRINT SCREEN BOILERPLATE
130 CLS
        :PRINT@(0,0),QNAME$;
        :PRINT@(0,27),QTYPE$;
        :PRINT@(0,76),QP AGE$;
        :PRINT@(1,0),DASH$;
135 PRINT@(22,0),DASH$;
        :PRINT@(23,0),QINST$;
        :PRINT@(2,0),;
140 RETURN
145 '
150 ' SUBROUTINE - WAIT FOR LEGAL LETTER INPUT
155 A$=INPUT$(1)
160 IF A$=CHR$(5) THEN END
165 IF INSTR(LEGAL$,A$)=0 THEN 155
170 TEST%=ASC(A$)
175 IF TEST%>=97 AND TEST%<=122 THEN A$=CHR$(TEST%-32)
180 RETURN
185 '
190 '
195 ' SUBROUTINE - WAIT FOR <ENTER> INPUT
200 A$=INPUT$(1)
205 IF A$=CHR$(5) THEN END
210 IF A$<>CHR$(13) THEN 195
215 RETURN
220 '
225 ' SUBROUTINE - CHECK FOR LEGAL JUMP PAGE NUMBERS
230 IF PTEST%<1 OR PTEST%>9999 THEN FLAG%=1 ELSE FLAG%=0
235 RETURN
240 '
245 ' SUBROUTINE - FULL SCREEN INPUT ROUTINE
250 LC%=1
        :CC%=1
255 PRINT@(LC%+1,CC%-1),;
```

```

260 A$=INKEY$ 'A$=INPUT$(1)
265 IF A$="" THEN 260
270 IF A$<>CHR$(13) THEN 305 ' <ENTER>
275 TEXT$(LC%)=LEFT$(TEXT$(LC%),CC%-1)
280 CC%=1
285 LC%=LC%+1
290 IF LC%>=21 THEN 540
295 PRINT CHR$(30);
      :GOTO 255

300 '
305 IF A$<>CHR$(8) THEN 340 ' BACKSPACE (<-->)
310 IF CC%=1 THEN 255
315 TEXT$(LC%)=LEFT$(TEXT$(LC%),CC%-2)
320 PRINT A$;
325 CC%=CC%-1
330 GOTO 255
335 '
340 IF A$<>CHR$(9) AND A$<>CHR$(25) THEN 375 ' TAB (-->)
345 IF CC%>75 THEN 255 ' NOT ENOUGH SPACE TO TAB
350 TEXT$(LC%)=TEXT$(LC%)+STRING$(5,32)
355 CC%=CC%+5
360 PRINT STRING$(5,32);
365 GOTO 255
370 '
375 IF ASC(A$)<>5 THEN 395 ' CTRL<E> (END PAGE INPUT)
380 TEXT$(LC%)=LEFT$(TEXT$(LC%),CC%-1)
385 RETURN
390 '
395 IF ASC(A$)<>17 THEN 415 ' CTRL<Q> (QUIT PAGE EDITOR
- NO SAVE)
400 ERASE TEXT$
405 RETURN
410 '
415 IF ASC(A$)<32 OR ASC(A$)>126 THEN 255 ' VALID ASCII
CHARACTER
420 PRINT A$;
425 TEXT$(LC%)=TEXT$(LC%)+A$
430 CC%=CC%+1
435 IF CC%=81 THEN 450
440 GOTO 255
445 '
450 IF LC%=20 THEN 540
455 A$=INKEY$
      :IF A$="" THEN 455
460 IF A$<>CHR$(32) THEN 490 ' NO WORD WRAP REQUIRED
465 TEXT$(LC%)=LEFT$(TEXT$(LC%),80)
470 LC%=LC%+1
      :CC%=1
475 IF LC%=21 THEN 540
480 GOTO 255
485 '
490 TEST%=80
495 TEST$=MID$(TEXT$(LC%),TEST%,1)

```

```

500 IF INSTR(" /-",TEST$)=0 THEN TEST%=TEST%-1
      :GOTO 495 ELSE
505 TEXT$(LC%+1)=RIGHT$(TEXT$(LC%),80-TEST%)+A$
510 TEXT$(LC%)=LEFT$(TEXT$(LC%),TEST%)
515 IF TEST%<80 THEN PRINT@(LC%+1,TEST%),CHR$(30);
520 PRINT@(LC%+2,0),TEXT$(LC%+1);
525 CC%=82-TEST%
530 LC%=LC%+1
535 GOTO 255
540 PRINT@(23,0),CHR$(30);"                Page full!   Press Ctrl
      <E> to continue.";
      :PRINT@(23,0),;
545 A$=INKEY$
      :IF A$="" THEN 545
550 IF ASC(A$)<>5 THEN 545 ELSE LC%=20
      :RETURN
555 '
560 '   SUBROUTINE - CREATE LESSON TABLE FILE
565 OPEN "D",1,TEXT$,81
570 FIELD 1,1 AS BUF1$,5 AS BUF2$,5 AS BUF3$,5 AS BUF4$,5 AS
      BUF5$,5 AS BUF6$,5 AS BUF7$,1 AS BUF8$,3 AS BUF9$,46 AS
      DUMMY$
575 COUNT=0
580 LASTREC=LOF(1)
585 FOR I=1 TO LASTREC
590 GET 1,I
595 IF BUF1$=" " OR BUF1$="*" THEN 625
600 COUNT=COUNT+1
605 TYPE$(COUNT)=BUF1$
610 START%(COUNT)=LOC(1)
615 MORE%(COUNT)=VAL(BUF9$)
620 PAGE%(COUNT)=VAL(BUF2$)
625 NEXT I
630 CLOSE 1
635 OPEN "O",2,TABLE$
640 FOR I=1 TO COUNT
645 WRITE#2,PAGE%(I),START%(I),MORE%(I),TYPE$(I)
650 NEXT I
655 CLOSE 2
660 RETURN
665 '
670 '   SUBROUTINE - READ LESSON TABLE INTO MEMORY
675 QNAME$=TNAME$:QINST$=STRING$(20,32)+"Loading lesson tabl
      e...please wait."
      :QPAGE$=""
      :QTYPE$=""
      :GOSUB 125
680 PRINT@(23,0),;
685 OPEN "I",2,TABLE$
690 I=1
695 IF EOF(2) THEN 715
700 INPUT#2,PAGE%(I),START%(I),MORE%(I),TYPE$(I)
705 I=I+1

```

```

710 GOTO 695
715 CLOSE 2
720 NUMPAGES%=I-1
725 '   SORT TABLE INTO PAGE # SEQUENCE
730 FOR I=1 TO NUMPAGES%-1
735 FOR J=I+1 TO NUMPAGES%
740 IF PAGE%(I)>PAGE%(J) THEN ELSE 765
745 SWAP PAGE%(I),PAGE%(J)
750 SWAP START%(I),START%(J)
755 SWAP MORE%(I),MORE%(J)
760 SWAP TYPE$(I),TYPE$(J)
765 NEXT J
770 NEXT I
775 RETURN
780 '
785 '   SUBROUTINE - FIND CORRESPONDING TABLE SUBSCRIPT FOR
      QPAGE%
790 FOR I=1 TO NUMPAGES%
795 IF PAGE%(I)=QPAGE% THEN QMAT%=I
      :RETURN
800 NEXT I
805 QMAT%=-1
      :RETURN
810 '
815 '   SUBROUTINE - READ LESSON PAGE INTO MEMORY
820 GET 1,START%(QMAT%)
825 TYPE$=BUF1$
830 AJUMP%=VAL(BUF3$)
835 BJUMP%=VAL(BUF4$)
840 CJUMP%=VAL(BUF5$)
845 DJUMP%=VAL(BUF6$)
850 EJUMP%=VAL(BUF7$)
855 ANSWER$=BUF8$
860 MORE%=VAL(BUF9$)
865 FOR I=1 TO MORE%
870 GET 1,(START%(QMAT%)+I)
875 DUMMY$=BUF10$
880 TEXT$(I)=BUF11$
885 NEXT I
890 RETURN
895 '
900 '   SUBROUTINE - INPUT LESSON SCREEN
905 '   GET PAGE NUMBER
910 QNAME$=TNAME$
      :QTYPE$=""
      :QPAGE$=""
      :QINST$=QDATA$
      :GOSUB 125
915 PRINT@(3,15),CHR$(30);
920 INPUT"Enter page number: ",PAGE:IF PAGE>9999 THEN 915 EL
      SE PAGE%=PAGE
925 IF PAGE%=9999 OR PAGE%=0 THEN RETURN
930 '   IF FIRST SCREEN, ENSURE NUMBERED AS PAGE 1

```

```

935 IF REC=1 AND PAGE%=1 OR REC>1 THEN 955
940 QNAME$=TNAME$
      :QTYPE$=""
      :QPAGE$=""
      :QINST$=ENTER$
      :GOSUB 125
945 PRINT@(3,15),"The first page of a lesson must be page 1!";
950 PRINT@(23,0),;
      :GOSUB 195
      :GOTO 905
955 ' ENSURE PAGE NUMBER IN LEGAL LIMITS
960 IF PAGE%>=1 AND PAGE%<=9999 THEN 980
965 QNAME$=TNAME$
      :QTYPE$=""
      :QPAGE$=""
      :QINST$=ENTER$
      :GOSUB 125
970 PRINT@(3,15),PAGE%;" is not a valid page number!";
975 PRINT@(23,0),;
      :GOSUB 195
      :GOTO 905
980 ' ENSURE DUPLICATE PAGE NUMBER NOT BEING ENTERED
985 FOR I=1 TO NUMPAGES%
990 IF PAGE%=PAGE%(I) THEN 1010
995 NEXT I
1000 NUMPAGES%=NUMPAGES%+1
1005 GOTO 1030
1010 QNAME$=TNAME$
      :QTYPE$=""
      :QPAGE$=""
      :QINST$=ENTER$
      :GOSUB 125
1015 PRINT@(3,5),"Page #";PAGE%;" has already been used! Do
      not duplicate page numbers!";
1020 PRINT@(23,0),;
      :GOSUB 195
      :GOTO 905
1025 '
1030 ' GET PAGE TYPE TO ENTER
1035 QNAME$=TNAME$
      :QTYPE$=""
      :QPAGE$=STR$(PAGE%)
      :QINST$=PROMPT$
      :GOSUB 125
1040 PRINT@(3,15),"<A> Input text page";
1045 PRINT@(4,15),"<B> Input multiple choice question page";
1050 PRINT@(5,15),"<C> Input true/false question page";
1055 PRINT@(23,0),;
      :LEGAL$="ABCabc"
      :GOSUB 150
1060 IF A$="A" THEN TYPE$="#"
      :QTYPE$=TP$

```

```

1065 IF A$="B" THEN TYPE$="?"
      :QTYPE$=MCQP$
1070 IF A$="C" THEN TYPE$="&"
      :QTYPE$=TFQP$
1075 QNAME$=TNAME$
      :QPAGE$=STR$(PAGE%)
      :QINST$=QEDIT$
      :GOSUB 125
1080 GOSUB 245
1085 '
1090 '   GET ADDITIONAL DATA REQUIRED FOR EACH PAGE TYPE
1095 PRINT@(23,0),CHR$(30);QDATA$;
1100 IF TYPE$="#" THEN 1115
1105 IF TYPE$="?" THEN 1150
1110 IF TYPE$="&" THEN 1255
1115 '   GET ADDITIONAL DATA FOR TEXT PAGE
1120 PRINT@(20,0),CHR$(30);
1125 PRINT@(21,0),CHR$(30);
1130 PRINT@(20,20),CHR$(30);
1135 INPUT"Jump-to page: ",AJUMP:IF AJUMP>9999 THEN 1130 ELS
      E AJUMP%=AJUMP
      :PTEST%=AJUMP%
      :GOSUB 225
1140 IF FLAG%=1 THEN 1120
1145 GOTO 1315
1150 '   GET ADDITIONAL DATA FOR MULTIPLE CHOICE QUESTION
      PAGE
1155 FOR I=15 TO 21
      :PRINT@(I,0),CHR$(30);
      :NEXT I
1160 PRINT@(15,20),"Correct answer: ";
      :LEGAL$="ABCDEabcde"
      :GOSUB 150
      :PRINT A$;
      :ANSWER$=A$
1165 PRINT@(16,20),CHR$(30);
1170 INPUT"A-jump page   : ",AJUMP
      :IF AJUMP>9999 THEN 1165 ELSE AJUMP%=AJUMP
      :PTEST%=AJUMP%
      :GOSUB 225
1175 IF FLAG%=1 THEN 1165
1180 PRINT@(17,20),CHR$(30);
1185 INPUT"B-jump page   : ",BJUMP
      :IF BJUMP>9999 THEN 1180 ELSE BJUMP%=BJUMP
      :PTEST%=BJUMP%
      :GOSUB 225
1190 IF FLAG%=1 THEN 1180
1195 PRINT@(18,20),CHR$(30);
1200 INPUT"C-jump page   : ",CJUMP
      :IF CJUMP>9999 THEN 1195 ELSE CJUMP%=CJUMP
      :PTEST%=CJUMP%
      :GOSUB 225
1205 IF FLAG%=1 THEN 1195

```

```

1210 PRINT@(19,20),CHR$(30);
1215 INPUT"D-jump page  : ",DJUMP
      :IF DJUMP>9999 THEN 1210 ELSE DJUMP%=DJUMP
      :PTEST%=DJUMP%
      :GOSUB 225
1220 IF FLAG%=1 THEN 1210
1225 PRINT@(20,20),CHR$(30);
1230 INPUT"E-jump page  : ",EJUMP
      :IF EJUMP>9999 THEN 1225 ELSE EJUMP%=EJUMP
      :PTEST%=EJUMP%
      :GOSUB 225
1235 IF FLAG%=1 THEN 1225
1240 TYPE$="?"
1245 GOTO 1315
1250 '
1255 '   GET ADDITIONAL DATA FOR TRUE/FALSE QUESTION PAGE
1260 FOR I=17 TO 21:PRINT@(I,0),CHR$(30);
      :NEXT I
1265 PRINT@(18,20),"Correct answer: ";:LEGAL$="Tftf"
      :GOSUB 150
      :PRINT A$;
      :ANSWER$=A$
1270 PRINT@(19,20),CHR$(30);
1275 INPUT"T-jump page  : ",AJUMP
      :IF AJUMP>9999 THEN 1270 ELSE AJUMP%=AJUMP
      :PTEST%=AJUMP%
      :GOSUB 225
1280 IF FLAG%=1 THEN 1270
1285 PRINT@(20,20),CHR$(30);
1290 INPUT"F-jump page  : ",BJUMP
      :IF BJUMP>9999 THEN 1285 ELSE BJUMP%=BJUMP
      :PTEST%=BJUMP%
      :GOSUB 225
1295 IF FLAG%=1 THEN 1285
1300 TYPE$="?"
1305 GOTO 1315
1310 '
1315 '   GET ALL OTHER PAGE DATA AND WRITE HEADER RECORD TO
      DISK
1320 MORE%=LC%
1325 LSET BUF1$=TYPE$
1330 LSET BUF2$=STR$(PAGE%)
1335 LSET BUF3$=STR$(AJUMP%)
1340 LSET BUF4$=STR$(BJUMP%)
1345 LSET BUF5$=STR$(CJUMP%)
1350 LSET BUF6$=STR$(DJUMP%)
1355 LSET BUF7$=STR$(EJUMP%)
1360 LSET BUF8$=ANSWER$
1365 LSET BUF9$=STR$(MORE%)
1370 LSET DUMMY$=""
1375 START%=REC
1380 PUT 1,REC
1385 '

```

```

1390 '   WRITE TEXT RECORDS TO DISK
1395 FOR I=1 TO MORE%
1400 REC=REC+1
1405 LSET BUF10$=" "
1410 LSET BUF11$=TEXT$(I)
1415 PUT 1,REC
1420 NEXT I
1425 REC=REC+1
1430 '
1435 '   UPDATE LESSON TABLE
1440 PAGE%(NUMPAGES%)=PAGE%
      :START%(NUMPAGES%)=START%
      :MORE%(NUMPAGES%)=MORE%
      :TYPE$(NUMPAGES%)=TYPE$
1445 '   RETURN TO GET NEXT PAGE
1450 ERASE TEXT$
      :DIM TEXT$(20)
1455 GOTO 905
1460 '
1465 '   SUBROUTINE - GET DISK FILENAME AND PRINT ERRORS
1470 '   PRINT DISK INSTRUCTIONS
1475 QTYPE$=""
      :QPAGES$=""
      :QINST$=ENTER$
      :GOSUB 125
1480 PRINT@(3,10),"Insert the disk containing the lesson fil
      es in drive 1";
1485 PRINT@(23,0),;
1490 GOSUB 195
1495 '
1500 QTYPE$=""
      :QPAGES$=""
      :QINST$=QDATA$
      :GOSUB 125
1505 PRINT@(3,5),"Enter lesson name (maximum of 8 characters
      ; do not include";
      :PRINT@(4,5),;
1510 INPUT"extension; <ENTER> to abort): ",TNAME$
1515 IF TNAME$="" THEN CLOSE
      :ON ERROR GOTO 17000
      :GOTO 11000
1520 FOR I=1 TO LEN(TNAME$)
1525 TEST%=ASC(MID$(TNAME$,I,1))
1530 IF TEST%>=97 AND TEST%<=122 THEN MID$(TNAME$,I,1)=CHR$(
      TEST%-32)
1535 NEXT I
1540 '
1545 '   CHECK FOR NEEDED FILES ON DISK
1550 TEXT$=TNAME$+"/TXT"
1555 TABLE$=TNAME$+"/TAB"
1560 STUFILE$=TNAME$+"/STU"
1565 ON ERROR GOTO 1590
1570 IF INSTR(NEED$,"A")<>0 THEN QTEST$=TEXT$

```

```

        :OPEN "I",2,QTEST$
        :CLOSE 2
1575 IF INSTR(NEED$, "B") <> 0 THEN QTEST$=TABLE$
        :OPEN "I",2,QTEST$
        :CLOSE 2
1580 IF INSTR(NEED$, "C") <> 0 THEN QTEST$=STUFILES$
        :OPEN "I",2,QTEST$:CLOSE 2
1585 CLOSE
        :ON ERROR GOTO 17000
        :RETURN

1590 '
1595 QNAME$="ERROR"
        :QPAGE$=""
        :QINST$=ENTERS$
        :GOSUB 125
1600 IF ERR=53 THEN PRINT@(3,15),QTEST$;" is not on this dis
        k!";
        :GOTO 1620
1605 IF ERR=57 THEN PRINT@(3,15),"A device input/output erro
        r has occurred!";
        :GOTO 1620
1610 IF ERR=64 THEN PRINT@(3,15),TNAME$;" is not a valid
        lesson name!";
        :GOTO 1620
1615 PRINT@(3,15),"An unknown disk error has occurred!";
1620 RESUME 1625
1625 PRINT@(23,0),;
1630 GOSUB 195
1635 GOTO 1500
1640 CLOSE
        :ON ERROR GOTO 17000
        :RETURN

1645 '
1650 ' SUBROUTINE - DISPLAY LESSON PAGE
1655 FOR I=1 TO MORE%(QMAT%)
1660 PRINT TEXT$(I);
1665 NEXT I
1670 RETURN
1675 '
10000 '*****
10005 '* CONSTANT TABLE AND DEFINED FUNCTIONS *
10010 '* (LINES 10000-10999) *
10015 '*****
10020 '
10025 OPTION BASE 1
        :ON ERROR GOTO 17000
10030 DASH$=STRING$(80,45)
10035 PROMPT$=STRING$(22,32)+"Press <letter> of your choice.
        "
10040 QDATA$=STRING$(14,32)+"Enter requested data and press
        <ENTER> to continue."
10045 QEDIT$=STRING$(10,32)+"Enter Text"+STRING$(10,32)+"Ctr
        l<E> to End"+STRING$(10,32)+"Ctrl<Q> to Quit"

```

```

10050 MCQP$="Multiple Choice Question Page"
10055 TP$=STRING$(10,32)+"Text Page"
10060 TFQP$=STRING$(2,32)+"True/False Question Page"
10065 ENTER$=STRING$(22,32)+"Press <ENTER> to continue."
10070 YN$=STRING$(10,32)+"<Y>es      <N>o"+STRING$(25,32)
10075 '
11000 '*****
11005 '*          MAIN PROGRAM          *
11010 '*          (LINES 11000-39999)  *
11015 '*****
11020 '
11025 '   INITIALIZE COUNTERS
11030 NUMPAGES%=0
11035 '
11040 '   PRINT MAIN MENU AND ROUTE TO PROPER PORTION OF
        PROGRAM
11045 QNAME$="MAIN MENU"
        :QPAGES$=""
        :QINST$=PROMPT$
        :QTYPE$=""
        :GOSUB 125
11050 PRINT@(3,15),"<A> Create a lesson file."
11055 PRINT@(4,15),"<B> Edit a lesson file."
11060 PRINT@(5,15),"<C> Print a lesson file."
11065 PRINT@(6,15),"<D> Print a student file report."
11070 PRINT@(7,15),"<E> Exit WRITE program."
11075 PRINT@(23,0),;
11080 LEGAL$="ABCDEabcde"
        :GOSUB 150
11085 IF A$="A" THEN 12000 ELSE IF A$="B" THEN 13000 ELSE IF
        A$="C" THEN 14000 ELSE IF A$="D" THEN 15000 ELSE IF A$
        ="E" THEN 16000
11090 '
12000 '   CREATE A LESSON FILE
12005 DIM TEXT$(20),PAGE%(200),MORE%(200),TYPE$(200),START%(
        200)
12010 '   PRINT DISK INSTRUCTIONS
12015 QNAME$="CREATE A LESSON FILE"
        :QTYPE$=""
        :QPAGES$=""
        :QINST$=ENTER$
        :GOSUB 125
12020 PRINT@(3,15),"Insert a properly formatted disk in driv
        e 1."
12025 PRINT@(23,0),;
        :GOSUB 195
12030 '
12035 '   GET LESSON FILE NAME
12040 QNAME$="CREATE A LESSON FILE"
        :QTYPE$=""
        :QPAGES$=""
        :QINST$=QDATA$
        :GOSUB 125

```

```

12045 PRINT@(3,5),"Enter lesson name (maximum of 8 character
      s; do not include";
      :PRINT@(4,5),;
12050 INPUT"extension; <ENTER> to abort): ",TNAMES$
12055 IF TNAMES$="" THEN GOTO 11000
12060 FOR I=1 TO LEN(TNAMES$)
12065 TEST%=ASC(MID$(TNAMES$,I,1))
12070 IF TEST%>=97 AND TEST%<=122 THEN MID$(TNAMES$,I,1)=CHR$
      (TEST%-32)
12075 NEXT I
12080 TEXT$=TNAMES$+"/TXT:1"
12085 TABLE$=TNAMES$+"/TAB:1"
12090 '
12095 '   OPEN LESSON FILE BUFFER, INITIALIZE RECORD
      COUNTER, AND START
12100 '   PAGE INPUT
12105 ON ERROR GOTO 12180
12110 OPEN "D",1,TEXT$,81
12115 FIELD 1,1 AS BUF1$,5 AS BUF2$,5 AS BUF3$,5 AS BUF4$,5
      AS BUF5$,5 AS BUF6$,5 AS BUF7$,1 AS BUF8$,3 AS BUF9$,4
      6 AS DUMMY$
12120 FIELD 1,1 AS BUF10$,80 AS BUF11$
12125 ON ERROR GOTO 17000
12130 REC=1
12135 GOSUB 900
12140 CLOSE
12145 '
12150 '   CREATE LESSON TABLE FILE
12155 QNAMES$=TNAMES$
      :QTYPE$=""
      :QPAGE$=""
      :QINST$=STRING$(14,32)+"Writing lesson files to di
      sk...please wait."
      :GOSUB 125
12160 GOSUB 560
12165 CLOSE
      :ERASE TEXT$,PAGE%,MORE%,TYPE$,START%
12170 CLS
      :GOTO 11025 '   RETURN TO MAIN MENU
12175 '
12180 '   ERROR HANDLING ROUTINE FOR FILE NAME TO CREATE
12185 QNAMES$="ERROR"
      :QTYPE$=""
      :QPAGE$=""
      :QINST$=ENTERS$
      :GOSUB 125
12190 IF ERR=57 THEN PRINT@(3,15),"A device input/output err
      or has occurred!"
      :GOTO 12205
12195 IF ERR=64 THEN PRINT@(3,15),TNAMES$;" is not a valid le
      sson name!";
      :GOTO 12205
12200 PRINT@(3,15),"An unknown disk error has occurred!";

```

```

12205 PRINT@(23,0),;
      :GOSUB 195
12210 RESUME 12215
12215 CLOSE
      :ON ERROR GOTO 17000
      :GOTO 12015
13000 ' EDIT A LESSON FILE
13005 QNAME$="EDIT A LESSON FILE"
13010 ' GET LESSON FILE NAME
13015 NEED$="AB"
      :GOSUB 1465
13020 DIM TEXT$(20),PAGE%(200),START%(200),MORE%(200),TYPE$(
200)
13025 '
13030 ' READ TABLE FILE INTO MEMORY
13035 GOSUB 670
13040 CLOSE:
      OPEN "D",1,TEXT$,81
13045 FIELD 1,1 AS BUF1$,5 AS BUF2$,5 AS BUF3$,5 AS BUF4$,5
      AS BUF5$,5 AS BUF6$,5 AS BUF7$,1 AS BUF8$,3 AS BUF9$,4
      6 AS DUMMY$
13050 FIELD 1,1 AS BUF10$,80 AS BUF11$
13055 '
13060 ' DISPLAY EDIT MAIN MENU
13065 QNAME$=TNAME$
      :QTYPE$=""
      :QPAGE$=""
      :QINST$=PROMPT$
      :GOSUB 125
13070 PRINT@(3,15),"<A> Add screen to lesson."
13075 PRINT@(4,15),"<B> Delete screen from lesson."
13080 PRINT@(5,15),"<C> Modify existing screen."
13085 PRINT@(6,15),"<D> Return to WRITE main menu."
13090 PRINT@(23,0),;
13095 LEGAL$="ABCDabcd"
      :GOSUB 150
13100 IF A$="A" THEN 13105 ELSE IF A$="B" THEN 13130 ELSE IF
      A$="C" THEN 13270 ELSE IF A$="D" THEN 13700
13105 ' ADD SCREEN TO LESSON
13110 ' GET CURRENT LAST RECORD
13115 REC=LOF(1)+1
13120 GOSUB 900
13125 GOTO 13060
13130 ' DELETE PAGE FROM EXISTING LESSON FILE
13135 ' GET PAGE NUMBER
13140 QNAME$=TNAME$
      :QTYPE$="DELETE A PAGE"
      :QPAGE$=""
      :QINST$=QDATA$
      :GOSUB 125
13145 PRINT@(3,15),CHR$(30);
13150 INPUT"Enter page number to delete: ",PAGE
      :IF PAGE>9999 THEN 13145 ELSE PAGE%=PAGE

```

```

13155 '   FIND TABLE SUBSCRIPT/READ LESSON PAGE INTO MEMORY
13160 QPAGE%=PAGE%
      :GOSUB 785
13165 IF QMAT%=-1 THEN PRINT@(5,15),"Page not found in lesso
      n table!";
      :PRINT@(23,0),CHR$(30);ENTER$;
      :PRINT@(23,0),;
      :GOSUB 195
      :GOTO 13060
13170 GOSUB 815
13175 '   DISPLAY PAGE
13180 QNAME$=TNAME$
      :QTYPE$="DELETE A PAGE"
      :QPAGE$=STR$(PAGE%)
      :QINST$=STRING$(15,32)+"<D> to Delete Page"+STRING
      $(15,32)+"<Q> to Abort"
      :GOSUB 125
13185 GOSUB 1650
13190 '   GET DELETE DECISION
13195 PRINT@(23,0),;
13200 LEGAL$="QqDd"
      :GOSUB 150
13205 IF A$="Q" THEN ERASE TEXT$
      :DIM TEXT$(20)
      :GOTO 13060
13210 FOR REC=START%(QMAT%) TO START%(QMAT%)+MORE%(QMAT%)
13215 LSET BUF10$="*"
13220 LSET BUF11$=STRING$(80,42)
13225 PUT 1,REC
13230 NEXT REC
13235 '   UPDATE LESSON TABLE
13240 FOR I=QMAT% TO NUMPAGES%
13245 PAGE%(I)=PAGE%(I+1)
      :START%(I)=START%(I+1)
      :MORE%(I)=MORE%(I+1)
      :TYPE$(I)=TYPE$(I+1)
      :NEXT I
13250 NUMPAGES%=NUMPAGES%-1
13255 ERASE TEXT$
      :DIM TEXT$(20)
13260 GOTO 13060
13265 '
13270 '   MODIFY EXISTING PAGE
13275 '   GET PAGE NUMBER
13280 QNAME$=TNAME$
      :QTYPE$="MODIFY A PAGE"
      :QPAGE$=""
      :QINST$=QDATA$
      :GOSUB 125
13285 PRINT@(3,15),CHR$(30);
13290 INPUT"Enter page number to modify: ",PAGE
      :IF PAGE>9999 THEN 13285 ELSE PAGE%=PAGE
13295 '   FIND TABLE SUBSCRIPT/READ LESSON PAGE INTO MEMORY

```

```

13300 QPAGE%=PAGE%
      :GOSUB 785
13305 IF QMAT%=-1 THEN PRINT@(5,15),"Page not found in less
n table!";
      :PRINT@(23,0),CHR$(30);ENTER$;
      :PRINT@(23,0),;
      :GOSUB 195
      :GOTO 13060
13310 GOSUB 815
13315 ' DISPLAY PAGE
13320 QNAME$=TNAME$
      :QTYPE$="MODIFY A PAGE"
      :QPAGE$=STR$(PAGE%)
      :QINST$=" Ctrl <E>nd text edit Ctrl <Q>uit and
cancel Ctrl <D>elete character"
      :GOSUB 125
13325 GOSUB 1650
13330 PRINT@(2,0),;
13335 A$=INKEY$
13340 IF A$="" THEN 13335
13345 IF ASC(A$)=17 THEN ERASE TEXT$
      :DIM TEXT$(20)
      :GOTO 13060 ' QUIT EDITOR
13350 IF ASC(A$)=5 THEN GOTO 13390 ' END TEXT EDITING
13355 IF ASC(A$)=11 THEN IF ROW(1)=2 THEN 13335 ELSE PRINT@
(ROW(1)-1,POS(1)-1),;
      :GOTO 13335 ' UP ARROW
13360 IF ASC(A$)=10 THEN IF ROW(1)=MORE%+1 THEN 13335 ELSE P
RINT@(ROW(1)+1,POS(1)-1),;
      :GOTO 13335 ' DOWN ARROW
13365 IF ASC(A$)=8 THEN IF POS(1)=1 THEN 13335 ELSE PRINT@
(ROW(1),POS(1)-2),;
      :GOTO 13335 ' LEFT ARROW
13370 IF ASC(A$)=9 THEN IF POS(1)=80 THEN 13335 ELSE PRINT@
(ROW(1),POS(1)),;
      :GOTO 13335 ' RIGHT ARROW
13375 IF ASC(A$)=4 THEN TPOS=POS(1)
      :TROW=ROW(1)
      :TEXT$(TROW-1)=LEFT$(TEXT$(TROW-1),TPOS-1)+RIGHT$(
TEXT$(TROW-1),80-TPOS)+CHR$(32)
      :PRINT@(TROW,0),TEXT$(TROW-1);
      :PRINT@(TROW,TPOS-1),;
      :GOTO 13335 ' DELETE CHARACTER
13380 IF ASC(A$)>=32 AND ASC(A$)<=126 THEN MID$(TEXT$(ROW(1)
-1),POS(1),1)=A$
      :PRINT A$;
      :IF ROW(1)=MORE%+2 AND POS(1)=1 THEN PRINT CHR$(24
);
      :GOTO 13335 ' OVERSTRIKE WITH VALID ASCII
CHARACTER
13385 GOTO 13335 ' INVALID KEY ENTRY
13390 ' END TEXT EDITING - CHANGE ADDITIONAL DATA?
13395 ' CHANGE PAGE NUMBER?

```

```

13400 FOR I=19 TO 21
      :PRINT@(I,0),CHR$(30),;
      :NEXT I
13405 PRINT@(20,20),CHR$(30);"Page number: ";PAGE%;
      :PRINT@(23,0),CHR$(30);" Change page number?";YNS;
      :PRINT@(23,0),;
13410 LEGAL$="YyNn"
      :GOSUB 150
13415 IF A$<>"Y" THEN 13460
13420 PRINT@(23,0),CHR$(30);QDATA$;
13425 PRINT@(20,20),CHR$(30);"New page number: ";
13430 INPUT"",PAGE
      :IF PAGE>9999 THEN 13425
13435 FOR I=1 TO NUMPAGES%
      :IF PAGE=PAGE%(I) THEN 13445 ELSE NEXT I
13440 PAGE%=PAGE
      :PAGE%(QMAT%)=PAGE%
      :GOTO 13405
13445 PRINT@(20,20),CHR$(30);PAGE;" already used!";
13450 PRINT@(23,0),CHR$(30);ENTERS;
      :PRINT@(23,0),;
      :GOSUB 195
13455 GOTO 13405
13460 ' ASSIGN TEMPORARY TYPE$ TO T/F QUESTION
13465 IF TYPE$="?" AND (ANSWER$="T" OR ANSWER$="F") THEN TY
      PE$="&"
13470 IF TYPE$="#" THEN 13485
13475 IF TYPE$="?" THEN 13510
13480 IF TYPE$="&" THEN 13595
13485 ' TEXT PAGE - CHANGE JUMP PAGE?
13490 PRINT@(20,20),CHR$(30);"Jump page: ";AJUMP%;
13495 PRINT@(23,0),CHR$(30);" Change jump page?";YNS;
      :PRINT@(23,0),;
      :LEGAL$="YyNn"
      :GOSUB 150
13500 IF A$<>"Y" THEN 13670 ELSE PRINT@(23,0),CHR$(30);QDATA
      $;
      :PRINT@(20,20),CHR$(30);"Jump page: ";
      :INPUT"",AJUMP:IF AJUMP<10000 AND AJUMP>0 THEN AJU
      MP%=AJUMP ELSE GOTO 13500
13505 GOTO 13485
13510 ' MULTIPLE CHOICE QUESTION
13515 ' CHANGE CORRECT ANSWER?
13520 PRINT@(20,20),CHR$(30);"Correct answer: ";ANSWER$;
13525 PRINT@(23,0),CHR$(30);" Change correct answer?";YNS;
      :PRINT@(23,0),;
      :LEGAL$="YyNn"
      :GOSUB 150
13530 IF A$<>"Y" THEN 13540

```

```

13535 PRINT@(23,0),CHR$(30);PROMPT$;
      :PRINT@(20,20),CHR$(30);"Correct answer: ";
      :LEGAL$="ABCDEabcde"
      :GOSUB 150:PRINT A$;
      :ANSWER$=A$
      :GOTO 13520
13540 ' CHANGE ANSWER JUMP PAGES?
13545 PRINT@(20,0)," AJUMP: ";AJUMP%;" BJUMP: ";BJUMP%
      ;" CJUMP: ";CJUMP%;" DJUMP: ";DJUMP%;" EJUMP:
      ";EJUMP%;
13550 PRINT@(23,0)," Change answer jump pages?";YN$;
      :PRINT@(23,0),;
      :LEGAL$="YyNn"
      :GOSUB 150
13555 IF A$<>"Y" THEN 13670
13560 PRINT@(23,0),CHR$(30);PROMPT$;
      :PRINT@(23,0)," Which one?";
      :PRINT@(23,0),;
      :LEGAL$="ABCDEabcde"
      :GOSUB 150
      :PRINT@(24,1),CHR$(30);QDATA$;
      :PRINT@(20,0),CHR$(30);
13565 IF A$="A" THEN PRINT@(20,20),CHR$(30);"AJUMP: ";
      :INPUT"",AJUMP
      :IF AJUMP>0 AND AJUMP<10000 THEN AJUMP%=AJUMP ELSE
      GOTO 13565
13570 IF A$="B" THEN PRINT@(20,20),CHR$(30);"BJUMP: ";
      :INPUT"",BJUMP
      :IF BJUMP>0 AND BJUMP<10000 THEN BJUMP%=BJUMP ELSE
      GOTO 13570
13575 IF A$="C" THEN PRINT@(20,20),CHR$(30);"CJUMP: ";
      :INPUT"",CJUMP
      :IF CJUMP>0 AND CJUMP<10000 THEN CJUMP%=CJUMP ELSE
      GOTO 13575
13580 IF A$="D" THEN PRINT@(20,20),CHR$(30);"DJUMP: ";
      :INPUT"",DJUMP
      :IF DJUMP>0 AND DJUMP<10000 THEN DJUMP%=DJUMP ELSE
      GOTO 13580
13585 IF A$="E" THEN PRINT@(20,20),CHR$(30);"EJUMP: ";
      :INPUT"",EJUMP
      :IF EJUMP>0 AND EJUMP<10000 THEN EJUMP%=EJUMP ELSE
      GOTO 13585
13590 GOTO 13540
13595 ' TRUE/FALSE QUESTION
13600 ' CHANGE CORRECT ANSWER?
13605 PRINT@(20,20),CHR$(30);"Correct answer: ";ANSWER$;
13610 PRINT@(23,0),CHR$(30);" Change correct answer?";YN$;
      :PRINT@(23,0),;
      :LEGAL$="YyNn"
      :GOSUB 150
13615 IF A$<>"Y" THEN 13625

```

```

13620 PRINT@(23,0),CHR$(30);PROMPT$;
      :PRINT@(20,0),CHR$(30);
      :PRINT@ (20,20),"Correct answer: ";
      :LEGAL$="TtFf"
      :GOSUB 150:PRINT A$;
      :ANSWER$=A$
      :GOTO 13600
13625 ' CHANGE ANSWER JUMP PAGES?
13630 PRINT@(20,0),CHR$(30);STRING$(24,32);"TJUMP: "; AJUMP%
; " FJUMP: ";BJUMP%;
13635 PRINT@(23,0)," Change answer jump pages?";YN$;
      :PRINT@(23,0),;
      :LEGAL$="YyNn"
      :GOSUB 150
13640 IF A$<>"Y" THEN TYPE$="?"
      :GOTO 13670
13645 PRINT@(23,0),CHR$(30);PROMPT$;
      :PRINT@(23,0)," Which one?";
      :PRINT@(23,0),;:LEGAL$="TtFf"
      :GOSUB 150
13650 PRINT@(20,0),CHR$(30);
13655 IF A$="T" THEN PRINT@(20,20),CHR$(30);"TJUMP: ";
      :INPUT"",AJUMP
      :IF AJUMP>0 AND AJUMP<10000 THEN AJUMP%=AJUMP ELSE
      GOTO 13655
13660 IF A$="F" THEN PRINT@(20,20),CHR$(30);"FJUMP: ";
      :INPUT"",BJUMP
      :IF BJUMP>0 AND BJUMP<10000 THEN BJUMP%=BJUMP ELSE
      GOTO 13660
13665 GOTO 13630
13670 ' END EDIT - WRITE PAGE TO DISK
13675 LSET BUF1$=TYPE$
      :LSET BUF2$=STR$(PAGE%)
      :LSET BUF3$=STR$(AJUMP%)
      :LSET BUF4$=STR$(BJUMP%)
      :LSET BUF5$=STR$(CJUMP%)
      :LSET BUF6$=STR$(DJUMP%)
      :LSET BUF7$=STR$(EJUMP%)
      :LSET BUF8$=ANSWER$
      :LSET BUF9$=STR$(MORE%)
      :LSET DUMMY$=""
13680 REC=START%(QMAT%)
13685 PUT 1,REC
13690 FOR I=1 TO MORE%
      :REC=REC+1
      :LSET BUF10$=" "
      :LSET BUF11$=TEXT$(I)
      :PUT 1,REC
      :NEXT I
13695 ERASE TEXT$
      :DIM TEXT$(20)
      :GOTO 13060
13700 ' EXIT EDITOR - RETURN TO MAIN MENU

```

```

13705 QNAME$="EXIT EDITOR"
      :QPAGE$=""
      :QTYPE$=""
      :QINST$=STRING$(14,32)+"Writing lesson files to di
      sk...please wait."
      :GOSUB 125
13710 CLOSE
13715 GOSUB 560
13720 CLOSE
13725 ERASE PAGE%,START%,MORE%,TYPE$,TEXT$
13730 GOTO 11025
13735 '
14000 ' PRINT A LESSON FILE
14005 DIM TEXT$(20),PAGE%(200),MORE%(200),TYPE$(200),START%(
200)
14010 ' GET LESSON FILE NAME
14015 QNAME$="PRINT A LESSON FILE"
14020 NEED$="AB"
14025 GOSUB 1465
14030 GOSUB 670
14035 ' ASSIGN QUESTION NUMBERS
14040 QNUM%=1
14045 FOR I=1 TO Numpages%
14050 IF TYPE$(I)<>"?" THEN 14065
14055 QNUM%(I)=QNUM%
14060 QNUM%=QNUM%+1
14065 NEXT I
14070 '
14075 QNAME$=TNAME$
      :QTYPE$="PRINT A LESSON FILE"
      :QPAGE$=""
      :QINST$=ENTER$
      :GOSUB 125
14080 PRINT@(3,15),"Ensure printer is ready for printing.";
14085 PRINT@(23,0),;
14090 GOSUB 195
14095 '
14100 ' OPEN TEXT FILE
14105 OPEN "D",1,TEXT$,81
14110 FIELD 1,1 AS BUF1$,5 AS BUF2$,5 AS BUF3$,5 AS BUF4$,5
      AS BUF5$,5 AS BUF6$,5 AS BUF7$,1 AS BUF8$,3 AS BUF9$,4
      6 AS DUMMY$
14115 FIELD 1,1 AS BUF10$,80 AS BUF11$
14120 '
14125 ' READ PAGES OF TEXT AND OUTPUT TO PRINTER
14130 FOR QMAT%=1 TO Numpages%
14135 GOSUB 815
14140 LPRINT DASH$
14145 LPRINT
14150 LPRINT "Page # ";PAGE%(QMAT%);
14155 IF TYPE$(QMAT%)="?" THEN LPRINT "/ Question #";QNUM%(Q
MAT%) ELSE LPRINT
14160 LPRINT

```

```

14165 FOR J=1 TO MORE%
14170 LPRINT TEXT$(J)
14175 NEXT J
14180 LPRINT
14185 IF TYPE$(QMAT%)="#" THEN LPRINT "Jump:";AJUMP%
      :GOTO 14200
14190 IF TYPE$(QMAT%)="?" AND INSTR("TF",ANSWER$)<>0 THEN LP
RINT"T-jump:";AJUMP%;" F-jump:";BJUMP%; TAB(69);"Corr
ect: ";ANSWER$
      :GOTO 14200
14195 IF TYPE$(QMAT%)="?" AND INSTR("ABCDE",ANSWER$)<>0 THEN
      LPRINT"A-jump:";AJUMP%;" B-jump:";BJUMP%;" C-jump:
";CJUMP%;" D-jump:";DJUMP%;" E-jump:";EJUMP%;TAB(69)
";Correct: ";ANSWER$
14200 LPRINT
14205 ERASE TEXT$
      :DIM TEXT$(20)
14210 NEXT QMAT%
14215 LPRINT DASH$
14220 LPRINT CHR$(12);
14225 CLOSE
14230 ERASE PAGE%,START%,MORE%,TYPE$,TEXT$
14235 CLS
      :GOTO 11025      ' RETURN TO MAIN MENU
14240 '
15000 ' PRINT A STUDENT FILE REPORT
15005 QNAME$="PRINT A STUDENT FILE REPORT"
15010 NEED$="C"
      :GOSUB 1465
15015 '
15020 QNAME$=TNAME$
      :QTYPE$="PRINT A STUDENT FILE"
      :QPAGE$=""
      :QINST$=ENTER$
      :GOSUB 125
15025 PRINT@(3,15),"Ensure printer is ready for printing.";
15030 PRINT@(23,0),;
15035 GOSUB 195
15040 '
15045 ' PRINT HEADER INFORMATION
15050 LPRINT STRING$(26,32);TNAME$;" STUDENT FILE REPORT";TA
B(65);DATE$
15055 LPRINT
15060 LPRINT DASH$
15065 LPRINT"STUDENT NAME/DATE ASKED RIGHT WRONG PCT
      WRONG QUESTIONS-RESPONSES"
15070 LPRINT DASH$
15075 LPRINT
15080 '
15085 ' PRINT STUDENT INFORMATION
15090 OPEN "I",1,STUFILES$
15095 DIM WQUEST%(100),WQUEST$(100)
15100 IF EOF(1) THEN 15185

```

```

15105 INPUT#1,STUDENT$,QDATE$,TCOUNT%,RCOUNT%,WCOUNT%
15110 PCT=(RCOUNT%/TCOUNT%)*100
15115 LPRINT USING "\ \ \ \ \ ### \ \ \ \ \ ### \ \ \ \ \ ###
###.#";STUDENT$,QDATE$,TCOUNT%,RCOUNT%,WCOUNT%,PCT;
15120 IF WCOUNT%=0 GOTO 15170
15125 FOR I=1 TO WCOUNT%
15130 INPUT#1,WQUEST$(I),WQUEST$(I)
15135 NEXT I
15140 FOR I=1 TO WCOUNT% STEP 5
15145 LPRINT TAB(5I);
15150 FOR J=0 TO 4
15155 IF WQUEST$(I+J)<>0 THEN LPRINT USING "###_#! ";WQUEST%
(I+J);WQUEST$(I+J);
15160 NEXT J
15165 NEXT I
15170 LPRINT
: LPRINT
15175 ERASE WQUEST%,WQUEST$
15180 GOTO 15095
15185 ' END OF REPORT ROUTINE
15190 LPRINT DASH$
15195 LPRINT CHR$(12);
15200 ERASE WQUEST%,WQUEST$
15205 CLOSE
:CLS
:GOTO 11025 ' RETURN TO MAIN MENU
15210 '
16000 ' EXIT PROGRAM ROUTINE
16005 '
16010 CLS
:END
17000 ' PROGRAM FATAL ERROR ROUTINE
17005 STAR$=STRING$(10,32)+STRING$(60,42)
17010 CLS
17015 PRINT@(3,0),STAR$
:FOR I=4 TO 15
:PRINT@(I,10),"***";
:PRINT@(I,68),"***";
:NEXT I
:PRINT@(15,0),STAR$
17020 PRINT@(5,21),"FATAL PROGRAM ERROR DURING EXECUTION";
17025 PRINT@(7,25),"Error code ";ERR;" in line ";ERL;
17030 PRINT@(10,15),"Retain above data and refer to WRITE/BA
S User's Guide";
17035 PRINT@(13,23),"Press <ENTER> to restart program.";
17040 PRINT@(13,22),;
17045 A$=INKEY$
:IF A$<>CHR$(13) THEN 17045
17050 ERASE TEXT$,PAGE%,MORE%,TYPE$,START%
17055 CLOSE
:RESUME 11000
17060 END

```

WRITE/BAS Program Listing (MSDOS Version)

```
1 '*****
2 '* WRITE/BAS - COMPUTER-ASSISTED INSTRUCTION SOFTWARE *
3 '* ROBERT MASON, LT, SC, USN *
4 '* AIR FORCE INSTITUTE OF TECHNOLOGY *
5 '* SCHOOL OF SYSTEMS AND LOGISTICS *
6 '* MAY 1987 *
7 '* IBM/PC VERSION 01.00.00. *
8 '*****
9 '
10 GOTO 10000 ' JUMP TO START OF MAIN PROGRAM
15 '
100 '*****
105 '* SUBROUTINES *
110 '* (LINES 100-9999) *
115 '*****
120 '
125 ' SUBROUTINE - PRINT SCREEN BOILERPLATE
130 CLS
      :LOCATE 1,1
      :PRINT QNAME$;
      :LOCATE 1,28
      :PRINT QTYPE$;
      :LOCATE 1,77
      :PRINT QPAGE$;
      :LOCATE 2,1
      :PRINT DASH$;
135 LOCATE 23,1
      :PRINT DASH$;
      :LOCATE 24,1
      :PRINT QINST$;
      :LOCATE 3,1
140 RETURN
145 '
150 ' SUBROUTINE - WAIT FOR LEGAL LETTER INPUT
155 A$=INPUT$(1)
160 IF A$=CHR$(5) THEN END
165 IF INSTR(LEGAL$,A$)=0 THEN 155
170 TEST%=ASC(A$)
175 IF TEST%>=97 AND TEST%<=122 THEN A$=CHR$(TEST%-32)
180 RETURN
185 '
190 '
195 ' SUBROUTINE - WAIT FOR <ENTER> INPUT
200 A$=INPUT$(1)
205 IF A$=CHR$(5) THEN END
210 IF A$<>CHR$(13) THEN 195
215 RETURN
220 '
225 ' SUBROUTINE - CHECK FOR LEGAL JUMP PAGE NUMBERS
230 IF PTEST%<1 OR PTEST%>9999 THEN FLAG%=1 ELSE FLAG%=0
```

```

235 RETURN
240 '
245 '   SUBROUTINE - FULL SCREEN INPUT ROUTINE
250 LC%=1
      :CC%=1
255 LOCATE LC%+2,CC%
260 A$=INKEY$ 'A$=INPUT$(1)
265 IF A$="" THEN 260
270 IF A$<>CHR$(13) THEN 305 ' <ENTER>
275 TEXT$(LC%)=LEFT$(TEXT$(LC%),CC%-1)
280 CC%=1
285 LC%=LC%+1
290 IF LC%>=21 THEN 540
295 PRINT CHR$(30);
      :GOTO 255
300 '
305 IF A$<>CHR$(8) AND A$<>CHR$(0)+CHR$(75) AND A$<>CHR$(0)+
CHR$(83) THEN 340 ' BACKSPACE (<-->)
310 IF CC%=1 THEN 255
315 TEXT$(LC%)=LEFT$(TEXT$(LC%),CC%-2)
320 PRINT CHR$(29);CHR$(32);CHR$(29);
325 CC%=CC%-1
330 GOTO 255
335 '
340 IF A$<>CHR$(9) AND A$<>CHR$(0)+CHR$(77) THEN 375
' TAB (-->)
345 IF CC%>75 THEN 255 ' NOT ENOUGH SPACE TO TAB
350 TEXT$(LC%)=TEXT$(LC%)+STRING$(5,32)
355 CC%=CC%+5
360 PRINT STRING$(5,32);
365 GOTO 255
370 '
375 IF ASC(A$)<>5 THEN 395 ' CTRL<E> (END PAGE INPUT)
380 TEXT$(LC%)=LEFT$(TEXT$(LC%),CC%-1)
385 RETURN
390 '
395 IF ASC(A$)<>17 THEN 415 ' CTRL<Q> (QUIT PAGE EDITOR
- NO SAVE)
400 ERASE TEXTS
405 RETURN
410 '
415 IF ASC(A$)<32 OR ASC(A$)>126 THEN 255 ' VALID ASCII
CHARACTER
420 PRINT A$;
425 TEXT$(LC%)=TEXT$(LC%)+A$
430 CC%=CC%+1
435 IF CC%=81 THEN 450
440 GOTO 255
445 '
450 IF LC%=20 THEN 540
455 A$=INKEY$
      : IF A$="" THEN 455

```

```

460 IF A$=CHR$(8) OR A$=CHR$(0)+CHR$(75) OR A$=CHR$(0)+CHR$(
    83) THEN 305 ELSE IF A$<>CHR$(32) THEN 490 ' NO WORD
    WRAP REQUIRED
465 TEXT$(LC%)=LEFT$(TEXT$(LC%),80)
470 LC%=LC%+1
    :CC%=1
475 IF LC%=21 THEN 540
480 GOTO 255
485 '
490 TEST%=80
495 TEST$=MID$(TEXT$(LC%),TEST%,1)
500 IF INSTR("/- ",TEST$)=0 THEN TEST%=TEST%-1
    :GOTO 495 ELSE
505 TEXT$(LC%+1)=RIGHT$(TEXT$(LC%),80-TEST%)+A$
510 TEXT$(LC%)=LEFT$(TEXT$(LC%),TEST%)
515 LOCATE LC%+2,TEST%+1
    :PRINT STRING$(81-POS(0),32);
520 LOCATE LC%+3,1
    :PRINT TEXT$(LC%+1);
525 CC%=82-TEST%
530 LC%=LC%+1
535 GOTO 255
540 LOCATE 24,1
    :PRINT STRING$(81-POS(0),32);
    :LOCATE 24,1
    :PRINT"                Page full!  Press Ctrl<E> to con
        tinue.";
    :LOCATE 24,1
545 A$=INKEY$
    :IF A$="" THEN 545
550 IF ASC(A$)<>5 THEN 545 ELSE LC%=20
    :RETURN
555 '
560 ' SUBROUTINE - CREATE LESSON TABLE FILE
565 OPEN TEXT$ AS #1 LEN=81
570 FIELD #1,1 AS BUF1$,5 AS BUF2$,5 AS BUF3$,5 AS BUF4$,5 A
    S BUF5$,5 AS BUF6$,5 AS BUF7$,1 AS BUF8$,3 AS BUF9$,46 A
    S DUMMY$
575 COUNT=0
580 LASTREC=LOF(1)/81
585 FOR I=1 TO LASTREC
590 GET 1,I
595 IF BUF1$=" " OR BUF1$="*" THEN 625
600 COUNT=COUNT+1
605 TYPE$(COUNT)=BUF1$
610 START%(COUNT)=LOC(1)
615 MORE%(COUNT)=VAL(BUF9$)
620 PAGE%(COUNT)=VAL(BUF2$)
625 NEXT I
630 CLOSE 1
635 OPEN TABLE$ FOR OUTPUT AS #1
640 FOR I=1 TO COUNT
645 WRITE#1,PAGE%(I),START%(I),MORE%(I),TYPE$(I)

```

```

650 NEXT I
655 CLOSE 2
660 RETURN
665 '
670 ' SUBROUTINE - READ LESSON TABLE INTO MEMORY
675 QNAME$=TNAME$
      :QINST$=STRING$(20,32)+"Loading lesson table...ple
      :ase wait."
      :QPAGE$=""
      :QYTPES$=""
      :GOSUB 125
680 LOCATE 24,1
685 OPEN TABLE$ FOR INPUT AS #2
690 I=1
695 IF EOF(2) THEN 715
700 INPUT#2,PAGE%(I),START%(I),MORE%(I),TYPES(I)
705 I=I+1
710 GOTO 695
715 CLOSE 2
720 NUMPAGES%=I-1
725 ' SORT TABLE INTO PAGE # SEQUENCE
730 FOR I=1 TO NUMPAGES%-1
735 FOR J=I+1 TO NUMPAGES%
740 IF PAGE%(I)>PAGE%(J) THEN ELSE 765
745 SWAP PAGE%(I),PAGE%(J)
750 SWAP START%(I),START%(J)
755 SWAP MORE%(I),MORE%(J)
760 SWAP TYPES(I),TYPES(J)
765 NEXT J
770 NEXT I
775 RETURN
780 '
785 ' SUBROUTINE - FIND CORRESPONDING TABLE SUBSCRIPT FOR
      QPAGE%
790 FOR I=1 TO NUMPAGES%
795 IF PAGE%(I)=QPAGE% THEN QMAT%=I
      :RETURN
800 NEXT I
805 QMAT%=-1
      :RETURN
810 '
815 ' SUBROUTINE - READ LESSON PAGE INTO MEMORY
820 GET 1,START%(QMAT%)
825 TYPES$=BUF1$
830 AJUMP%=VAL(BUF3$)
835 BJUMP%=VAL(BUF4$)
840 CJUMP%=VAL(BUF5$)
845 DJUMP%=VAL(BUF6$)
850 EJUMP%=VAL(BUF7$)
855 ANSWERS$=BUF8$
860 MORE%=VAL(BUF9$)
865 FOR I=1 TO MORE%
870 GET 1,(START%(QMAT%)+I)

```

```

875 DUMMY$=BUF10$
880 TEXT$(I)=BUF11$
885 NEXT I
890 RETURN
895 '
900 '   SUBROUTINE - INPUT LESSON SCREEN
905 '   GET PAGE NUMBER
910 QNAME$=TNAME$
      :QTYPE$=""
      :QPAGE$=""
      :QINST$=QDATA$
      :GOSUB 125
915 LOCATE 4,16
      :PRINT STRING$(81-POS(0),32);
      :LOCATE 4,16
920 INPUT"Enter page number: ",PAGE
      :IF PAGE>9999 THEN 915 ELSE PAGE%=PAGE
925 IF PAGE%=9999 OR PAGE%=0 THEN RETURN
930 '   IF FIRST SCREEN, ENSURE NUMBERED AS PAGE 1
935 IF REC=1 AND PAGE%=1 OR REC>1 THEN 955
940 QNAME$=TNAME$
      :QTYPE$=""
      :QPAGE$=""
      :QINST$=ENTER$
      :GOSUB 125
945 LOCATE 4,16
      :PRINT"The first page of a lesson must be page 1!"
      ;
950 LOCATE 24,1
      :GOSUB 195
      :GOTO 905
955 '   ENSURE PAGE NUMBER IN LEGAL LIMITS
960 IF PAGE%>=1 AND PAGE%<=9999 THEN 980
965 QNAME$=TNAME$
      :QTYPE$=""
      :QPAGE$=""
      :QINST$=ENTER$
      :GOSUB 125
970 LOCATE 4,16
      :PRINT PAGE%;" is not a valid page number!";
975 LOCATE 24,1
      :GOSUB 195
      :GOTO 905
980 '   ENSURE DUPLICATE PAGE NUMBER NOT BEING ENTERED
985 FOR I=1 TO NUMPAGES%
990 IF PAGE%=PAGE%(I) THEN 1010
995 NEXT I
1000 NUMPAGES%=NUMPAGES%+1
1005 GOTO 1030

```

```

1010 QNAME$=TNAME$
      :QTYPE$=""
      :QPAGE$=""
      :QINST$=ENTER$
      :GOSUB 125
1015 LOCATE 4,6
      :PRINT "Page #";PAGE%;" has already been used
      ! Do not duplicate page numbers!";
1020 LOCATE 24,1
      :GOSUB 195
      :GOTO 905

1025 '
1030 '   GET PAGE TYPE TO ENTER
1035 QNAME$=TNAME$
      :QTYPE$=""
      :QPAGE$=STR$(PAGE%)
      :QINST$=PROMPT$
      :GOSUB 125
1040 LOCATE 4,16
      :PRINT"<A> Input text page";
1045 LOCATE 5,16
      :PRINT"<B> Input multiple choice question page";
1050 LOCATE 6,16
      :PRINT"<C> Input true/false question page";
1055 LOCATE 24,1
      :LEGAL$="ABCabc"
      :GOSUB 150
1060 IF A$="A" THEN TYPE$="#"
      :QTYPE$=TP$
1065 IF A$="B" THEN TYPE$="?"
      :QTYPE$=MCQP$
1070 IF A$="C" THEN TYPE$="&"
      :QTYPE$=TFQP$
1075 QNAME$=TNAME$
      :QPAGE$=STR$(PAGE%)
      :QINST$=QEDIT$
      :GOSUB 125
1080 GOSUB 245
1085 '
1090 '   GET ADDITIONAL DATA REQUIRED FOR EACH PAGE TYPE
1095 LOCATE 24,1
      :PRINT STRING$(81-POS(0),32);
      :LOCATE 24,1
      :PRINT QDATA$;
1100 IF TYPE$="#" THEN 1115
1105 IF TYPE$="?" THEN 1150
1110 IF TYPE$="&" THEN 1255
1115 '   GET ADDITIONAL DATA FOR TEXT PAGE
1120 LOCATE 21,1
      :PRINT STRING$(81-POS(0),32);
1125 LOCATE 22,1
      :PRINT STRING$(81-POS(0),32);

```

```

1130 LOCATE 21,21
      :PRINT STRING$(81-POS(0),32);
      :LOCATE 21,21
1135 INPUT"Jump-to page: ",AJUMP
      :IF AJUMP>9999 THEN 1130 ELSE AJUMP%=AJUMP
      :PTEST%=AJUMP%
      :GOSUB 225
1145 GOTO 1315
1150 ' GET ADDITIONAL DATA FOR MULTIPLE CHOICE QUESTION
      PAGE
1155 FOR I=16 TO 22
      :LOCATE I,1
      :PRINT STRING$(81-POS(0),32);
      :NEXT I
1160 LOCATE 16,21:PRINT"Correct answer: ";
      :LEGAL$="ABCDEabcde"
      :GOSUB 150
      :PRINT A$;
      :ANSWER$=A$
1165 LOCATE 17,21
      :PRINT STRING$(81-POS(0),32);
      :LOCATE 17,21
1170 INPUT"A-jump page : ",AJUMP
      :IF AJUMP>9999 THEN 1165 ELSE AJUMP%=AJUMP
      :PTEST%=AJUMP%
      :GOSUB 225
1175 IF FLAG%=1 THEN 1165
1180 LOCATE 18,21
      :PRINT STRING$(81-POS(0),32);
      :LOCATE 18,21
1185 INPUT"B-jump page : ",BJUMP
      :IF BJUMP>9999 THEN 1180 ELSE BJUMP%=BJUMP
      :PTEST%=BJUMP%
      :GOSUB 225
1190 IF FLAG%=1 THEN 1180
1195 LOCATE 19,21
      :PRINT STRING$(81-POS(0),32);
      :LOCATE 19,21
1200 INPUT"C-jump page : ",CJUMP
      :IF CJUMP>9999 THEN 1195 ELSE CJUMP%=CJUMP
      :PTEST%=CJUMP%
      :GOSUB 225
1205 IF FLAG%=1 THEN 1195
1210 LOCATE 20,21
      :PRINT STRING$(81-POS(0),32);
      :LOCATE 20,21
1215 INPUT"D-jump page : ",DJUMP
      :IF DJUMP>9999 THEN 1210 ELSE DJUMP%=DJUMP
      :PTEST%=DJUMP%
      :GOSUB 225
1220 IF FLAG%=1 THEN 1210

```

```

1225 LOCATE 21,21
      :PRINT STRING$(81-POS(0),32);
      :LOCATE 21,21
1230 INPUT"E-jump page   : ",EJUMP
      :IF EJUMP>9999 THEN 1225 ELSE EJUMP%=EJUMP
      :PTEST%=EJUMP%
      :GOSUB 225
1235 IF FLAG%=1 THEN 1225
1240 TYPE$="?"
1245 GOTO 1315
1250 '
1255 '   GET ADDITIONAL DATA FOR TRUE/FALSE QUESTION PAGE
1260 FOR I=18 TO 22
      :LOCATE I,1
      :PRINT STRING$(81-POS(0),32);
      :NEXT I
1265 LOCATE 19,21
      :PRINT"Correct answer: ";
      :LEGAL$="Tftf"
      :GOSUB 150
      :PRINT A$;
      :ANSWER%=A$
1270 LOCATE 20,21
      :PRINT STRING$(81-POS(0),32);
      :LOCATE 20,21
1275 INPUT"T-jump page   : ",AJUMP
      :IF AJUMP>9999 THEN 1270 ELSE AJUMP%=AJUMP
      :PTEST%=AJUMP%
      :GOSUB 225
1280 IF FLAG%=1 THEN 1270
1285 LOCATE 21,21
      :PRINT STRING$(81-POS(0),32);
      :LOCATE 21,21
1290 INPUT"F-jump page   : ",BJUMP
      :IF BJUMP>9999 THEN 1285 ELSE BJUMP%=BJUMP
      :PTEST%=BJUMP%
      :GOSUB 225
1295 IF FLAG%=1 THEN 1285
1300 TYPE$="?"
1305 GOTO 1315
1310 '
1315 '   GET ALL OTHER PAGE DATA AND WRITE HEADER RECORD TO
      DISK
1320 MORE%=LC%
1325 LSET BUF1%=TYPE$
1330 LSET BUF2%=STR$(PAGE%)
1335 LSET BUF3%=STR$(AJUMP%)
1340 LSET BUF4%=STR$(BJUMP%)
1345 LSET BUF5%=STR$(CJUMP%)
1350 LSET BUF6%=STR$(DJUMP%)
1355 LSET BUF7%=STR$(EJUMP%)
1360 LSET BUF8%=ANSWER$
1365 LSET BUF9%=STR$(MORE%)

```

```

1370 LSET DUMMY$=""
1375 START%=REC
1380 PUT 1,REC
1385 '
1390 '   WRITE TEXT RECORDS TO DISK
1395 FOR I=1 TO MORE%
1400 REC=REC+1
1405 LSET BUF10$=" "
1410 LSET BUF11$=TEXT$(I)
1415 PUT 1,REC
1420 NEXT I
1425 REC=REC+1
1430 '
1435 '   UPDATE LESSON TABLE
1440 PAGE%(NUMPAGES%)=PAGE%
      :START%(NUMPAGES%)=START%
      :MORE%(NUMPAGES%)=MORE%
      :TYPE$(NUMPAGES%)=TYPE$
1445 '   RETURN TO GET NEXT PAGE
1450 ERASE TEXT$
      :DIM TEXT$(20)
1455 GOTO 905
1460 '
1465 '   SUBROUTINE - GET DISK FILENAME AND PRINT ERRORS
1470 '   PRINT DISK INSTRUCTIONS
1475 QTYPE$=""
      :QPAGES$=""
      :QINST$=ENTERS$
      :GOSUB 125
1480 LOCATE 4,11
      :PRINT"Insert the disk containing the lesson file
      s in drive A";
1485 LOCATE 24,1
1490 GOSUB 195
1495 '
1500 QTYPE$=""
      :QPAGES$=""
      :QINST$=QDATA$
      :GOSUB 125
1505 LOCATE 4,6
      :PRINT"Enter lesson name (maximum of 8 characters
      ; do not include";
      :LOCATE 5,6
1510 INPUT"extension; <ENTER> to abort): ",TNAME$
1515 IF TNAME$="" THEN CLOSE
      :ON ERROR GOTO 17000
      :GOTO 11000
1520 FOR I=1 TO LEN(TNAME$)
1525 TEST%=ASC(MID$(TNAME$,I,1))
1530 IF TEST%>=97 AND TEST%<=122 THEN MID$(TNAME$,I,1)=CHR$(
TEST%-32)
1535 NEXT I
1540 '

```

```

1545 ' CHECK FOR NEEDED FILES ON DISK
1550 TEXT$="A:"+TNAME$+".TXT"
1555 TABLE$="A:"+TNAME$+".TAB"
1560 STUFILE$="A:"+TNAME$+".STU"
1565 ON ERROR GOTO 1590
1570 IF INSTR(NEED$, "A") <> 0 THEN QTEST$=TEXT$
      :OPEN QTEST$ FOR INPUT AS #2
      :CLOSE #2
1575 IF INSTR(NEED$, "B") <> 0 THEN QTEST$=TABLE$
      :OPEN QTEST$ FOR INPUT AS #2
      :CLOSE #2
1580 IF INSTR(NEED$, "C") <> 0 THEN QTEST$=STUFILE$
      :OPEN QTEST$ FOR INPUT AS #2
      :CLOSE #2
1585 CLOSE
      :ON ERROR GOTO 17000
      :RETURN
1590 '
1595 QNAME$="ERROR"
      :QPAGE$=""
      :QINST$=ENTER$
      :GOSUB 125
1600 IF ERR=53 THEN LOCATE 4,16
      :PRINT QTEST$;" is not on this disk!";
      :GOTO 1620
1605 IF ERR=57 THEN LOCATE 4,16
      :PRINT"A device input/output error has occurred!"
      ;
      :GOTO 1620
1610 IF ERR=64 THEN PRINT@(3,15),TNAME$;" is not a valid les
      son name!";
      :GOTO 1620
1615 LOCATE 4,16
      :PRINT"An unknown disk error has occurred!";
1620 RESUME 1625
1625 LOCATE 24,1
1630 GOSUB 195
1635 GOTO 1500
1640 CLOSE
      :ON ERROR GOTO 17000
      :RETURN
1645 '
1650 ' SUBROUTINE - DISPLAY LESSON PAGE
1655 FOR I=1 TO MORE%(QMAT%)
1660 PRINT TEXT$(I);
1665 NEXT I
1670 RETURN
1675 '
10000 '*****
10005 '* CONSTANT TABLE AND DEFINED FUNCTIONS *
10010 '* (LINES 10000-10999) *
10015 '*****
10020 '

```

```

10025 OPTION BASE 1
      :KEY OFF
      :ON ERROR GOTO 17000
10030 DASH$=STRING$(80,45)
10035 PROMPT$=STRING$(22,32)+"Press <letter> of your choice.
      "
10040 QDATA$=STRING$(14,32)+"Enter requested data and press
      <ENTER> to continue."
10045 QEDIT$=STRING$(10,32)+"Enter Text"+STRING$(10,32)+"Ctr
      l<E> to End"+STRING$(10,32)+"Ctrl<Q> to Quit"
10050 MCQP$="Multiple Choice Question Page"
10055 TP$=STRING$(10,32)+"Text Page"
10060 TFQP$=STRING$(2,32)+"True/False Question Page"
10065 ENTER$=STRING$(22,32)+"Press <ENTER> to continue."
10070 YN$=STRING$(10,32)+"<Y>es      <N>o"+STRING$(25,32)
10075 CHAR8$=CHR$(29)+CHR$(32)+CHR$(29)
11000 '*****
11005 '*          MAIN PROGRAM          *
11010 '*          (LINES 11000-39999)    *
11015 '*****
11020 '
11025 '   INITIALIZE COUNTERS
11030 NUMPAGES%=0
11035 '
11040 '   PRINT MAIN MENU AND ROUTE TO PROPER PORTION OF
      PROGRAM
11045 QNAME$="MAIN MENU"
      :QPAGE$=""
      :QINST$=PROMPT$
      :QTYPE$=""
      :GOSUB 125
11050 LOCATE 4,16
      :PRINT"<A>  Create a lesson file."
11055 LOCATE 5,16
      :PRINT"<B>  Edit a lesson file."
11060 LOCATE 6,16
      :PRINT"<C>  Print a lesson file."
11065 LOCATE 7,16
      :PRINT"<D>  Print a student file report."
11070 LOCATE 8,16
      :PRINT"<E>  Exit WRITE program."
11075 LOCATE 24,1
11080 LEGAL$="ABCDEabcde"
      :GOSUB 150
11085 IF A$="A" THEN 12000 ELSE IF A$="B" THEN 13000 ELSE IF
      A$="C" THEN 14000 ELSE IF A$="D" THEN 15000 ELSE IF A
      $="E" THEN 16000
      $="E" THEN 16000
11090 '
12000 '   CREATE A LESSON FILE
12005 DIM TEXT$(20),PAGE%(200),MORE%(200),TYPE$(200),START%(
      200)
12010 '   PRINT DISK INSTRUCTIONS

```

```

12015 QNAME$="CREATE A LESSON FILE"
      :QTYPE$=""
      :QPAGE$=""
      :QINST$=ENTER$
      :GOSUB 125
12020 LOCATE 4,16
      :PRINT"Insert a properly formatted disk in drive
      A."
12025 LOCATE 24,1
      :GOSUB 195
12030 '
12035 '   GET LESSON FILE NAME
12040 QNAME$="CREATE A LESSON FILE"
      :QTYPE$=""
      :QPAGE$=""
      :QINST$=QDATA$
      :GOSUB 125
12045 LOCATE 4,6
      :PRINT"Enter lesson name (maximum of 8 characters;
      do not include";
      :LOCATE 5,6
12050 INPUT"extension; <ENTER> to abort): ",TNAME$
12055 IF TNAME$="" THEN GOTO 11000
12060 FOR I=1 TO LEN(TNAME$)
12065 TEST%=ASC(MID$(TNAME$,I,1))
12070 IF TEST%>=97 AND TEST%<=122 THEN MID$(TNAME$,I,1)=CHR$
      (TEST%-32)
12075 NEXT I
12080 TEXT$="A:"+TNAME$+".TXT"
12085 TABLE$="A:"+TNAME$+".TAB"
12090 '
12095 '   OPEN LESSON FILE BUFFER, INITIALIZE RECORD
      COUNTER, AND START
12100 '   PAGE INPUT
12105 ON ERROR GOTO 12180
12110 OPEN TEXT$ AS #1 LEN=81
12115 FIELD #1,1 AS BUF1$,5 AS BUF2$,5 AS BUF3$,5 AS BUF4$,5
      AS BUF5$,5 AS BUF6$,5 AS BUF7$,1 AS BUF8$,3 AS BUF9$,
      46 AS DUMMY$
12120 FIELD #1,1 AS BUF10$,80 AS BUF11$
12125 ON ERROR GOTO 17000
12130 REC=1
12135 GOSUB 900
12140 CLOSE
12145 '
12150 '   CREATE LESSON TABLE FILE
12155 QNAME$=TNAME$
      :QYPIE$=""
      :QPAGE$=""
      :QINST$=STRING$(14,32)+"Writing lesson files to d
      isk...please wait."
      :GOSUB 125
12160 GOSUB 560

```

```

12165 CLOSE
      :ERASE TEXT$,PAGE%,MORE%,TYPE$,START%
12170 CLS
      :GOTO 11025      '   RETURN TO MAIN MENU
12175 '
12180 '   ERROR HANDLING ROUTINE FOR FILE NAME TO CREATE
12185 QNAME$="ERROR"
      :QTYPE$=""
      :QPAGE$=""
      :QINST$=ENTERS$
      :GOSUB 125
12190 IF ERR=57 THEN LOCATE 4,16
      :PRINT"A device input/output error has occurred!"
      :GOTO 12205
12195 IF ERR=64 THEN LOCATE 4,16
      :PRINT TNAME$;" is not a valid lesson name!";
      :GOTO 12205
12200 LOCATE 4,16
      :PRINT"An unknown disk error has occurred!";
12205 LOCATE 24,1
      :GOSUB 195
12210 RESUME 12215
12215 CLOSE
      :ON ERROR GOTO 17000
      :GOTO 12015
13000 '   EDIT A LESSON FILE
13005 QNAME$="EDIT A LESSON FILE"
13010 '   GET LESSON FILE NAME
13015 NEED$="AB"
      :GOSUB 1465
13020 DIM TEXT$(20),PAGE%(200),START%(200),MORE%(200),TYPE$(
      200)
13025 '
13030 '   READ TABLE FILE INTO MEMORY
13035 GOSUB 670
13040 CLOSE
      :OPEN TEXT$ AS #1 LEN=81
13045 FIELD #1,1 AS BUF1$,5 AS BUF2$,5 AS BUF3$,5 AS BUF4$,5
      AS BUF5$,5 AS BUF6$,5 AS BUF7$,1 AS BUF8$,3 AS BUF9$,
      46 AS DUMMY$
13050 FIELD #1,1 AS BUF10$,80 AS BUF11$
13055 '
13060 '   DISPLAY EDIT MAIN MENU
13065 QNAME$=TNAME$
      :QTYPE$=""
      :QPAGE$=""
      :QINST$=PROMPT$
      :GOSUB 125
13070 LOCATE 4,16
      :PRINT"<A> Add screen to lesson."
13075 LOCATE 5,16
      :PRINT"<B> Delete screen from lesson."

```

```

13080 LOCATE 6,16
      :PRINT"<C> Modify existing screen."
13085 LOCATE 7,16
      :PRINT"<D> Return to WRITE main menu."
13090 LOCATE 24,1
13095 LEGAL$="ABCDabcd"
      :GOSUB 150
13100 IF A$="A" THEN 13105 ELSE IF A$="B" THEN 13130 ELSE IF
      A$="C" THEN 13270 ELSE IF A$="D" THEN 13700
13105 ' ADD SCREEN TO LESSON
13110 ' GET CURRENT LAST RECORD
13115 REC=(LOF(1)/81)+1
13120 GOSUB 900
13125 GOTO 13060
13130 ' DELETE PAGE FROM EXISTING LESSON FILE
13135 ' GET PAGE NUMBER
13140 QNAME$=TNAME$
      :QTYPE$="DELETE A PAGE"
      :QPAGE$=""
      :QINST$=QDATA$
      :GOSUB 125
13145 LOCATE 4,16
      :PRINT STRING$(81-POS(0),32);
      :LOCATE 4,16
13150 INPUT"Enter page number to delete: ",PAGE
      :IF PAGE>9999 THEN 13145 ELSE PAGE%=PAGE
13155 ' FIND TABLE SUBSCRIPT/READ LESSON PAGE INTO MEMORY
13160 QPAGE%=PAGE%
      :GOSUB 785
13165 IF QMAT%=-1 THEN LOCATE 6,16
      :PRINT"Page not found in lesson table!";
      :LOCATE 24,1
      :PRINT STRING$(81-POS(0),32);
      :LOCATE 24,1
      :PRINT ENTER$;
      :LOCATE 24,1
      :GOSUB 195
      :GOTO 13060
13170 GOSUB 815
13175 ' DISPLAY PAGE
13180 QNAME$=TNAME$
      :QTYPE$="DELETE A PAGE"
      :QPAGE$=STR$(PAGE%)
      :QINST$=STRING$(15,32)+"<D> to Delete Page"+STRING
      $(15,32)+"<Q> to Abort"
      :GOSUB 125
13185 GOSUB 1650
13190 ' GET DELETE DECISION
13195 LOCATE 24,1
13200 LEGAL$="QqDd"
      :GOSUB 150

```

```

13205 IF A$="Q" THEN ERASE TEXT$
      :DIM TEXT$(20)
      :GOTO 13060
13210 FOR REC=START%(QMAT%) TO START%(QMAT%)+MORE%(QMAT%)
13215 LSET BUF10$="*"
13220 LSET BUF11$=STRING$(80,42)
13225 PUT 1,REC
13230 NEXT REC
13235 ' UPDATE LESSON TABLE
13240 FOR I=QMAT% TO NUMPAGES%
13245 PAGE%(I)=PAGE%(I+1)
      :START%(I)=START%(I+1)
      :MORE%(I)=MORE%(I+1)
      :TYPE$(I)=TYPE$(I+1)
      :NEXT I
13250 NUMPAGES%=NUMPAGES%-1
13255 ERASE TEXT$
      :DIM TEXT$(20)
13260 GOTO 13060
13265 '
13270 ' MODIFY EXISTING PAGE
13275 ' GET PAGE NUMBER
13280 QNAME$=TNAME$
      :QTYPE$="MODIFY A PAGE"
      :QPAGE$=""
      :QINST$=QDATA$
      :GOSUB 125
13285 LOCATE 4,16
      :PRINT STRING$(81-POS(0),32);
      :LOCATE 4,16
13290 INPUT"Enter page number to modify: ",PAGE
      :IF PAGE>9999 THEN 13285 ELSE PAGE%=PAGE
13295 ' FIND TABLE SUBSCRIPT/READ LESSON PAGE INTO MEMORY
13300 QPAGE%=PAGE%
      :GOSUB 785
13305 IF QMAT%=-1 THEN LOCATE 6,16
      :PRINT"Page not found in lesson table!";
      :LOCATE 24,1
      :PRINT STRING$(81-POS(0),32);:LOCATE 24,1
      :PRINT ENTER$;
      :LOCATE 24,1
      :GOSUB 195
      :GOTO 13060
13310 GOSUB 815
13315 ' DISPLAY PAGE
13320 QNAME$=TNAME$
      :QTYPE$="MODIFY A PAGE"
      :QPAGE$=STR$(PAGE%)
      :QINST$=" Ctrl <E>nd text edit Ctrl <Q>uit and
      cancel Ctrl <D>elete character"
      :GOSUB 125
13325 GOSUB 1650
13330 LOCATE 3,1

```

```

13335 A$=INKEY$
13340 IF A$="" THEN 13335
13345 IF ASC(A$)=17 THEN ERASE TEXT$
      :DIM TEXT$(20)
      :GOTO 13060      '   QUIT EDITOR
13350 IF ASC(A$)=5 THEN GOTO 13390      '   END TEXT EDITING
13355 IF A$=CHR$(0)+CHR$(72) THEN IF CSRLIN=3 THEN 13335 ELSE
E LOCATE CSRLIN-1,POS(0)
      :GOTO 13335      '   UP ARROW
13360 IF A$=CHR$(0)+CHR$(80) THEN IF CSRLIN=MORE%+2 THEN 133
35 ELSE LOCATE CSRLIN+1,POS(0)
      :GOTO 13335      '   DOWN ARROW
13365 IF A$=CHR$(8) OR A$=CHR$(0)+CHR$(75) THEN IF POS(0)=1
THEN 13335 ELSE LOCATE CSRLIN,POS(0)-1
      :GOTO 13335      '   LEFT ARROW
13370 IF A$=CHR$(0)+CHR$(77) THEN IF POS(0)=80 THEN 13335 EL
SE LOCATE CSRLIN,POS(0)+1
      :GOTO 13335      '   RIGHT ARROW
13375 IF A$=CHR$(4) OR A$=CHR$(0)+CHR$(83) THEN TPOS=POS(0)
      :TROW=CSRLIN
      :TEXT$(TROW-2)=LEFT$(TEXT$(TROW-2),TPOS-1)+RIGHT$
(TEXT$(TROW-2),80-TPOS)+CHR$(32)
      :LOCATE TROW,1
      :PRINT TEXT$(TROW-2);
      :LOCATE TROW,TPOS
      :GOTO 13335      '   DELETE CHARACTER
13380 IF ASC(A$)>=32 AND ASC(A$)<=126 THEN MID$(TEXT$(CSRLIN
-2),POS(0),1)=A$
      :PRINT A$;
      :IF CSRLIN=MORE%+3 AND POS(0)=1 THEN PRINT CHAR$;
      :GOTO 13335      '   OVERSTRIKE WITH VALID ASCII
CHARACTER
13385 GOTO 13335      '   INVALID KEY ENTRY
13390      '   END TEXT EDITING - CHANGE ADDITIONAL DATA?
13395      '   CHANGE PAGE NUMBER?
13400 FOR I=20 TO 22
      :LOCATE I,1
      :PRINT STRING$(81-POS(0),32);
      :NEXT I
13405 LOCATE 21,21
      :PRINT STRING$(81-POS(0),32);
      :LOCATE 21,21
      :PRINT"Page number: ";PAGE%;
      :LOCATE 24,1
      :PRINT STRING$(81-POS(0),32);
      :LOCATE 24,1
      :PRINT" Change page number?";YN$;
      :LOCATE 24,1
13410 LEGAL$="YyNn"
      :GOSUB 150
13415 IF A$<>"Y" THEN 13460

```

```

13420 LOCATE 24,1
      :PRINT STRING$(81-POS(0),32);
      :LOCATE 24,1
      :PRINT QDATA$;
13425 LOCATE 21,21
      :PRINT STRING$(81-POS(0),32);
      :LOCATE 21,21
      :PRINT"New page number: ";
13430 INPUT"",PAGE
      :IF PAGE>9999 THEN 13425
13435 FOR I=1 TO NUMPAGES%
      :IF PAGE=PAGE%(I) THEN 13445 ELSE NEXT I
13440 PAGE%=PAGE
      :PAGE%(QMAT%)=PAGE%
      :GOTO 13405
13445 LOCATE 21,21
      :PRINT STRING$(81-POS(0),32);
      :LOCATE 21,21
      :PRINT PAGE;" already used!";
13450 LOCATE 24,1
      :PRINT STRING$(81-POS(0),32);
      :LOCATE 24,1
      :PRINT ENTER$;
      :LOCATE 24,1
      :GOSUB 195
13455 GOTO 13405
13460 ' ASSIGN TEMPORARY TYPE$ TO T/F QUESTION
13465 IF TYPE$="?" AND (ANSWER$="T" OR ANSWER$="F") THEN TY
      PE$="&"
13470 IF TYPE$="#" THEN 13485
13475 IF TYPE$="?" THEN 13510
13480 IF TYPE$="&" THEN 13595
13485 ' TEXT PAGE - CHANGE JUMP PAGE?
13490 LOCATE 21,21
      :PRINT STRING$(81-POS(0),32);
      :LOCATE 21,21
      :PRINT "Jump page: ";AJUMP%;
13495 LOCATE 24,1
      :PRINT STRING$(81-POS(0),32);
      :LOCATE 24,1
      :PRINT" Change jump page?";YN$;
      :LOCATE 24,1
      :LEGAL$="YyNn"
      :GOSUB 150

```

```

13500 IF A$<>"Y" THEN 13670 ELSE LOCATE 24,1
      :PRINT STRING$(81-POS(0),32);
      :LOCATE 24,1
      :PRINT QDATA$;
      :LOCATE 21,21
      :PRINT STRING$(81-POS(0),32);
      :LOCATE 21,21
      :PRINT"Jump page: ";
      :INPUT"",AJUMP
      :IF AJUMP<10000 AND AJUMP>0 THEN AJUMP%=AJUMP ELSE
        GOTO 13500
13505 GOTO 13485
13510 ' MULTIPLE CHOICE QUESTION
13515 ' CHANGE CORRECT ANSWER?
13520 LOCATE 21,21
      :PRINT STRING$(81-POS(0),32);
      :LOCATE 21,21
      :PRINT"Correct answer: ";ANSWER$;
13525 LOCATE 24,1
      :PRINT STRING$(81-POS(0),32);
      :LOCATE 24,1
      :PRINT" Change correct answer?";YN$;
      :LOCATE 24,1
      :LEGAL$="YyNn"
      :GOSUB 150
13530 IF A$<>"Y" THEN 13540
13535 LOCATE 24,1
      :PRINT STRING$(81-POS(0),32);
      :LOCATE 24,1
      :PRINT PROMPT$;
      :LOCATE 21,21
      :PRINT STRING$(81-POS(0),32);
      :LOCATE 21,21
      :PRINT"Correct answer: ";
      :LEGAL$="ABCDEabcde"
      :GOSUB 150
      :PRINT A$;
      :ANSWER$=A$
      :GOTO 13520
13540 ' CHANGE ANSWER JUMP PAGES?
13545 LOCATE 21,1
      :PRINT"      AJUMP: ";AJUMP%;"      BJUMP: ";BJUMP%;"
      :PRINT"      CJUMP: ";CJUMP%;"      DJUMP: ";DJUMP%;"      EJUM
      :PRINT"      P: ";EJUMP%;
13550 LOCATE 24,1
      :PRINT" Change answer jump pages?";YN$;
      :LOCATE 24,1
      :LEGAL$="YyNn"
      :GOSUB 150
13555 IF A$<>"Y" THEN 13670

```

```

13560 LOCATE 24,1
      :PRINT STRING$(81-POS(0),32);
      :LOCATE 24,1
      :PRINT PROMPT$;
      :LOCATE 24,1
      :PRINT" Which one?";
      :LOCATE 24,1
      :LEGAL$="ABCDEabcde"
      :GOSUB 150
      :LOCATE 24,1
      :PRINT QDATA$;
      :LOCATE 21,1
      :PRINT STRING$(81-POS(0),32);
      :LOCATE 21,1
13565 IF A$="A" THEN LOCATE 21,21
      :PRINT STRING$(81-POS(0),32);
      :LOCATE 21,21
      :PRINT"AJUMP: ";
      :INPUT"",AJUMP
      :IF AJUMP>0 AND AJUMP<10000 THEN AJUMP%=AJUMP ELSE
      GOTO 13565
13570 IF A$="B" THEN LOCATE 21,21
      :PRINT STRING$(81-POS(0),32);
      :LOCATE 21,21
      :PRINT"BJUMP: ";
      :INPUT"",BJUMP
      :IF BJUMP>0 AND BJUMP<10000 THEN BJUMP%=BJUMP ELSE
      GOTO 13570
13575 IF A$="C" THEN LOCATE 21,21
      :PRINT STRING$(81-POS(0),32);
      :LOCATE 21,21
      :PRINT"CJUMP: ";
      :INPUT"",CJUMP
      :IF CJUMP>0 AND CJUMP<10000 THEN CJUMP%=CJUMP ELSE
      GOTO 13575
13580 IF A$="D" THEN LOCATE 21,21
      :PRINT STRING$(81-POS(0),32);
      :LOCATE 21,21
      :PRINT"DJUMP: ";
      :INPUT"",DJUMP
      :IF DJUMP>0 AND DJUMP<10000 THEN DJUMP%=DJUMP ELSE
      GOTO 13580
13585 IF A$="E" THEN LOCATE 21,21
      :PRINT STRING$(81-POS(0),32);
      :LOCATE 21,21
      :PRINT"EJUMP: ";
      :INPUT"",EJUMP
      :IF EJUMP>0 AND EJUMP<10000 THEN EJUMP%=EJUMP ELSE
      GOTO 13585
13590 GOTO 13540
13595 ' TRUE/FALSE QUESTION
13600 ' CHANGE CORRECT ANSWER?

```

```

13605 LOCATE 21,21
      :PRINT STRING$(81-POS(0),32);
      :LOCATE 21,21
      :PRINT"Correct answer: ";ANSWER$;
13610 LOCATE 24,1
      :PRINT STRING$(81-POS(0),32);
      :LOCATE 24,1
      :PRINT" Change correct answer?";YN$;
      :LOCATE 24,1
      :LEGAL$="YyNn"
      :GOSUB 150
13615 IF A$<>"Y" THEN 13625
13620 LOCATE 24,1
      :PRINT STRING$(81-POS(0),32);
      :LOCATE 24,1
      :PRINT PROMPT$;
      :LOCATE 21,1
      :PRINT STRING$(81-POS(0),32);
      :LOCATE 21,21
      :PRINT"Correct answer: ";
      :LEGAL$="TtFf"
      :GOSUB 150
      :PRINT A$;
      :ANSWER$=A$
      :GOTO 13600
13625 ' CHANGE ANSWER JUMP PAGES?
13630 LOCATE 21,1
      :PRINT STRING$(81-POS(0),32);
      :LOCATE 21,1
      :PRINT STRING$(24,32);"TJUMP: ";AJUMP$;"
      FJUMP: ";BJUMP$;
13635 LOCATE 24,1
      :PRINT" Change answer jump pages?";YN$;
      :LOCATE 24,1
      :LEGAL$="YyNn"
      :GOSUB 150
13640 IF A$<>"Y" THEN TYPE$="?"
      :GOTO 13670
13645 LOCATE 24,1
      :PRINT STRING$(81-POS(0),32);
      :LOCATE 24,1
      :PRINT PROMPT$;
      :LOCATE 24,1
      :PRINT" Which one?";
      :LOCATE 24,1
      :LEGAL$="TtFf"
      :GOSUB 150
13650 LOCATE 21,1
      :PRINT STRING$(81-POS(0),32);
      :LOCATE 21,1

```

```

13655 IF A$="T" THEN LOCATE 21,21
      :PRINT STRING$(81-POS(0),32);
      :LOCATE 21,21
      :PRINT"IJUMP: ";
      :INPUT"",AJUMP
      :IF AJUMP>0 AND AJUMP<10000 THEN AJUMP%=AJUMP ELSE
      GOTO 13655
13660 IF A$="F" THEN LOCATE 21,21
      :PRINT STRING$(81-POS(0),32);
      :LOCATE 21,21
      :PRINT"FJUMP: ";
      :INPUT"",BJUMP
      :IF BJUMP>0 AND BJUMP<10000 THEN BJUMP%=BJUMP ELSE
      GOTO 13660
13665 TYPE$="?"
      :GOTO 13630
13670 ' END EDIT - WRITE PAGE TO DISK
13675 LSET BUF1$=TYPE$
      :LSET BUF2$=STR$(PAGE%)
      :LSET BUF3$=STR$(AJUMP%)
      :LSET BUF4$=STR$(BJUMP%)
      :LSET BUF5$=STR$(CJUMP%)
      :LSET BUF6$=STR$(DJUMP%)
      :LSET BUF7$=STR$(EJUMP%)
      :LSET BUF8$=ANSWER$
      :LSET BUF9$=STR$(MORE%)
      :LSET DUMMY$=""
13680 REC=START%(QMAT%)
13685 PUT 1,REC
13690 FOR I=1 TO MORE%
      :REC=REC+1
      :LSET BUF10$=" "
      :LSET BUF11$=TEXT$(I)
      :PUT 1,REC
      :NEXT I
13695 ERASE TEXT$
      :DIM TEXT$(20)
      :GOTO 13060
13700 ' EXIT EDITOR - RETURN TO MAIN MENU
13705 QNAME$="EXIT EDITOR"
      :QPAGE$=""
      :QTYPE$=""
      :QINST$=STRING$(14,32)+"Writing lesson files to di
      sk...please wait."
      :GOSUB 125
13710 CLOSE
13715 GOSUB 560
13720 CLOSE
13725 ERASE PAGE%,START%,MORE%,TYPE$,TEXT$
13730 GOTO 11025
13735 '
14000 ' PRINT A LESSON FILE

```

```

14005 DIM TEXT$(20),PAGE%(200),MORE%(200),TYPE$(200),START%(
      200)
14010 '   GET LESSON FILE NAME
14015 QNAME$="PRINT A LESSON FILE"
14020 NEED$="AB"
14025 GOSUB 1465
14030 GOSUB 670
14035 '   ASSIGN QUESTION NUMBERS
14040 QNUM%=1
14045 FOR I=1 TO Numpages%
14050 IF TYPE$(I)<>"?" THEN 14065
14055 QNUM%(I)=QNUM%
14060 QNUM%=QNUM%+1
14065 NEXT I
14070 '
14075 QNAME$=TNAME$
      :QTYPE$="PRINT A LESSON FILE"
      :QPAGE$=""
      :QINST$=ENTER$
      :GOSUB 125
14080 LOCATE 4,16
      :PRINT"Ensure printer is ready for printing.";
14085 LOCATE 24,1
14090 GOSUB 195
14095 '
14100 '   OPEN TEXT FILE
14105 OPEN TEXT$ AS #1 LEN=81
14110 FIELD #1,1 AS BUF1$,5 AS BUF2$,5 AS BUF3$,5 AS BUF4$,5
      AS BUF5$,5 AS BUF6$,5 AS BUF7$,1 AS BUF8$,3 AS BUF9$,
      46 AS DUMMY$
14115 FIELD #1,1 AS BUF10$,80 AS BUF11$
14120 '
14125 '   READ PAGES OF TEXT AND OUTPUT TO PRINTER
14130 FOR QMAT%=1 TO Numpages%
14135 GOSUB 815
14140 LPRINT DASH$
14145 LPRINT
14150 LPRINT "Page # ";PAGE%(QMAT%);
14155 IF TYPE$(QMAT%)="?" THEN LPRINT "/ Question #";QNUM%(Q
      MAT%) ELSE LPRINT
14160 LPRINT
14165 FOR J=1 TO MORE%
14170 LPRINT TEXT$(J)
14175 NEXT J
14180 LPRINT
14185 IF TYPE$(QMAT%)="#" THEN LPRINT "Jump:";AJUMP%
      :GOTO 14200
14190 IF TYPE$(QMAT%)="?" AND INSTR("TF",ANSWER$)<>0 THEN LP
      RINT"F-jump:";AJUMP%; " F-jump:";BJUMP%; TAB(69);"Corr
      ect: ";ANSWER$
      :GOTO 14200

```

```

14195 IF IYPE$(QMAT%)="?" AND INSTR("ABCDE",ANSWER$)<>0 THEN
      LPRINT"A-jump:";AJUMP%;" B-jump:";BJUMP%;" C-jump:"
      ;CJUMP%;" D-jump:";DJUMP%;" E-jump:";EJUMP%;TAB(69);
      "Correct: ";ANSWER$
14200 LPRINT
14205 ERASE TEXT$
      :DIM TEXT$(20)
14210 NEXT QMAT%
14215 LPRINT DASH$
14220 LPRINT CHR$(12);
14225 CLOSE
14230 ERASE PAGE%,START%,MORE%,TYPE$,TEXT$
14235 CLS
      :GOTO 11025 ' RETURN TO MAIN MENU
14240 '
15000 ' PRINT A STUDENT FILE REPORT
15005 QNAME$="PRINT A STUDENT FILE REPORT"
15010 NEED$="C"
      :GOSUB 1465
15015 '
15020 QNAME$=TNAME$
      :QTYPE$="PRINT A STUDENT FILE"
      :QPAGE$=""
      :QINST$=ENTER$
      :GOSUB 125
15025 LOCATE 4,16
      :PRINT"Ensure printer is ready for printing.";
15030 LOCATE 24,1
15035 GOSUB 195
15040 '
15045 ' PRINT HEADER INFORMATION
15050 LPRINT STRING$(26,32);TNAME$;" STUDENT FILE REPORT";TA
      B(65);DATE$
15055 LPRINT
15060 LPRINT DASH$
15065 LPRINT"STUDENT NAME/DATE ASKED RIGHT WRONG PCT
      WRONG QUESTIONS-RESPONSES"
15070 LPRINT DASH$
15075 LPRINT
15080 '
15085 ' PRINT STUDENT INFORMATION
15090 OPEN STUFILES FOR INPUT AS #1
15095 DIM WQUEST%(100),WQUEST$(100)
15100 IF EOF(1) THEN 15185
15105 INPUT#1,STUDENT$,QDATE$,TCOUNT%,RCOUNT%,WCOUNT%
15110 PCT=(RCOUNT%/TCOUNT%)*100
15115 LPRINT USING "\ \ \ \ ### ### ###
      ###.##";STUDENT$,QDATE$,TCOUNT%,RCOUNT%,WCOUNT%,PCT;
15120 IF WCOUNT%=0 GOTO 15170
15125 FOR I=1 TO WCOUNT%
15130 INPUT#1,WQUEST%(I),WQUEST$(I)
15135 NEXT I
15140 FOR I=1 TO WCOUNT% STEP 5

```

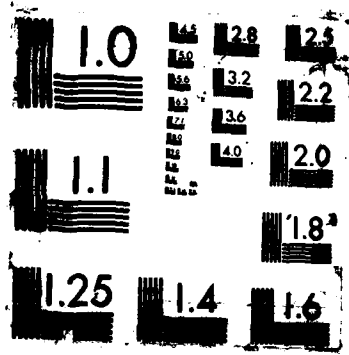
```

15145 LPRINT TAB(51);
15150 FOR J=0 TO 4
15155 IF WQUEST%(I+J)<>0 THEN LPRINT USING "###_! ";WQUEST%
      (I+J);WQUEST$(I+J);
15160 NEXT J
15165 NEXT I
15170 LPRINT
      :LPRINT
15175 ERASE WQUEST%,WQUEST$
15180 GOTO 15095
15185 '   END OF REPORT ROUTINE
15190 LPRINT DASH$
15195 LPRINT CHR$(12);
15200 ERASE WQUEST%,WQUEST$
15205 CLOSE
      :CLS
      :GOTO 11025   '   RETURN TO MAIN MENU

15210 '
16000 '   EXIT PROGRAM ROUTINE
16005 '
16010 CLS
      :END
17000 '   PROGRAM FATAL ERROR ROUTINE
17005 STAR$=STRING$(10,32)+STRING$(60,42)
17010 CLS
17015 LOCATE 4,1
      :PRINT STAR$;
      :FOR I=5 TO 16
      :LOCATE I,11
      :PRINT "***";
      :LOCATE I,69
      :PRINT "***";
      :NEXT I
      :LOCATE 16,1
      :PRINT STAR$;
17020 LOCATE 6,22
      :PRINT"FATAL PROGRAM ERROR DURING EXECUTION";
17025 LOCATE 8,26
      :PRINT"Error code: ";ERR;" in line ";ERL;
17030 LOCATE 11,14
      :PRINT"Retain above data and refer to WRITE/BAS Us
      er's Guide";
17035 LOCATE 14,24
      :PRINT"Press <ENTER> to restart program.";
17040 LOCATE 14,23
17045 A$=INKEY$
      :IF A$<>CHR$(13) THEN 17045
17050 '   ERASE TEXT$,PAGE%,MORE%,TYPE$,START%
17055 CLOSE
      :RESUME 11000
17060 END

```

Appendix E: WRITE/BAS Courseware Example

This appendix contains example courseware generated using the WRITE/BAS program. Figures E.1, E.2, E.3, and E.4 contain hardcopy prints of screens as they appear during lesson creating, editing, and printing. Although all possible screens have not been shown, a representative sample has been illustrated. Figures E.5 and E.6 illustrate the lesson and student file reports generated by the program.

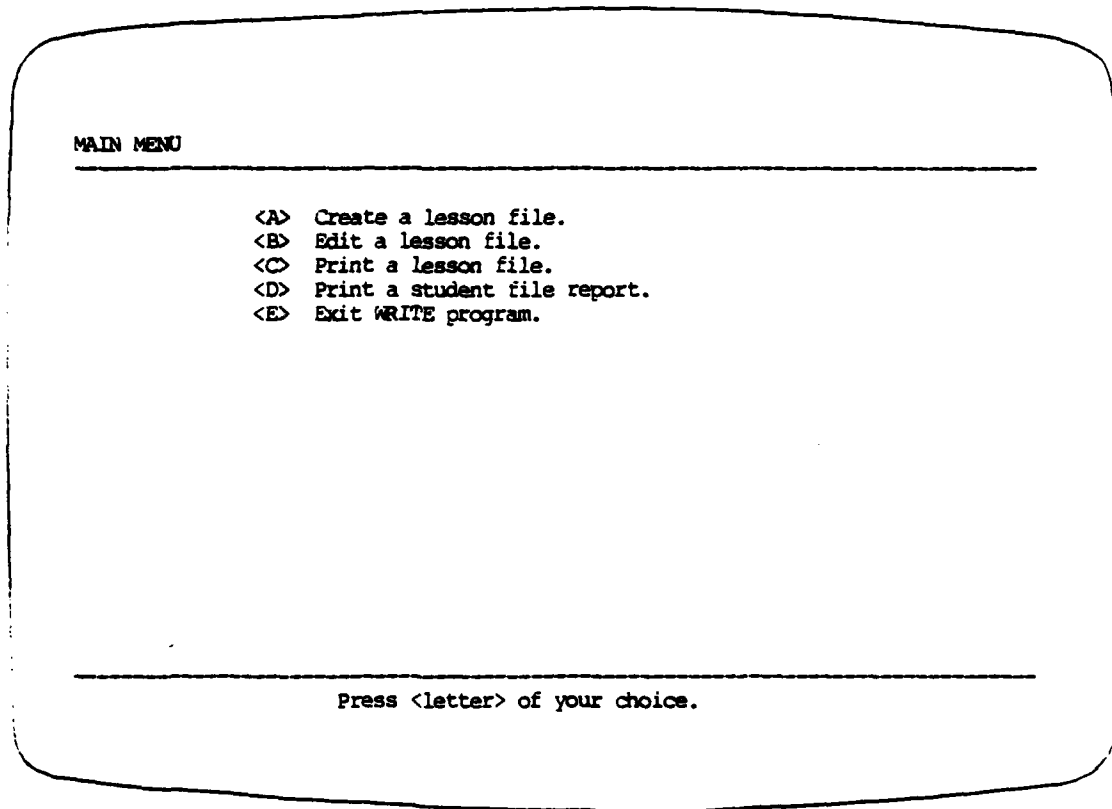

Initial screen of WRITE/BAS program.

Figure E.1: WRITE/BAS Main Menu

CREATE A LESSON FILE

Insert a properly formatted disk in drive 1.

Press <ENTER> to continue.

Disk instructions for creating a lesson file.

Figure E.2: Creating a Lesson File with WRITE/BAS

CREATE A LESSON FILE

Enter lesson name (maximum of 8 characters; do not include extension; <ENTER> to abort):

Enter requested data and press <ENTER> to continue.

Input of lesson file name for creating a lesson file.

Figure E.2: Creating a Lesson File with WRITE/BAS
(continued)

ERRCR

1.LESSON is not a valid lesson name!

Press <ENTER> to continue.

Typical error message following erroneous input of lesson file name. Pressing <ENTER> returns program to enter lesson file name prompt.

Figure E.2: Creating a Lesson File with WRITE/BAS
(continued)

LESSON1

Enter page number:

Enter requested data and press <ENTER> to continue.

Input of lesson screen page number. First page input is validated to ensure it is numbered as page 1. Additional page numbers are validated to ensure they are valid and that page numbers are not duplicated in the lesson.

Figure E.2: Creating a Lesson File with WRITE/BAS
(continued)

LESSON1

1

-
- <A> Input text page
 - Input multiple choice question page
 - <C> Input true/false question page

Press <letter> of your choice.

Input of type of page to generate.

Figure E.2: Creating a Lesson File with WRITE/BAS
(continued)

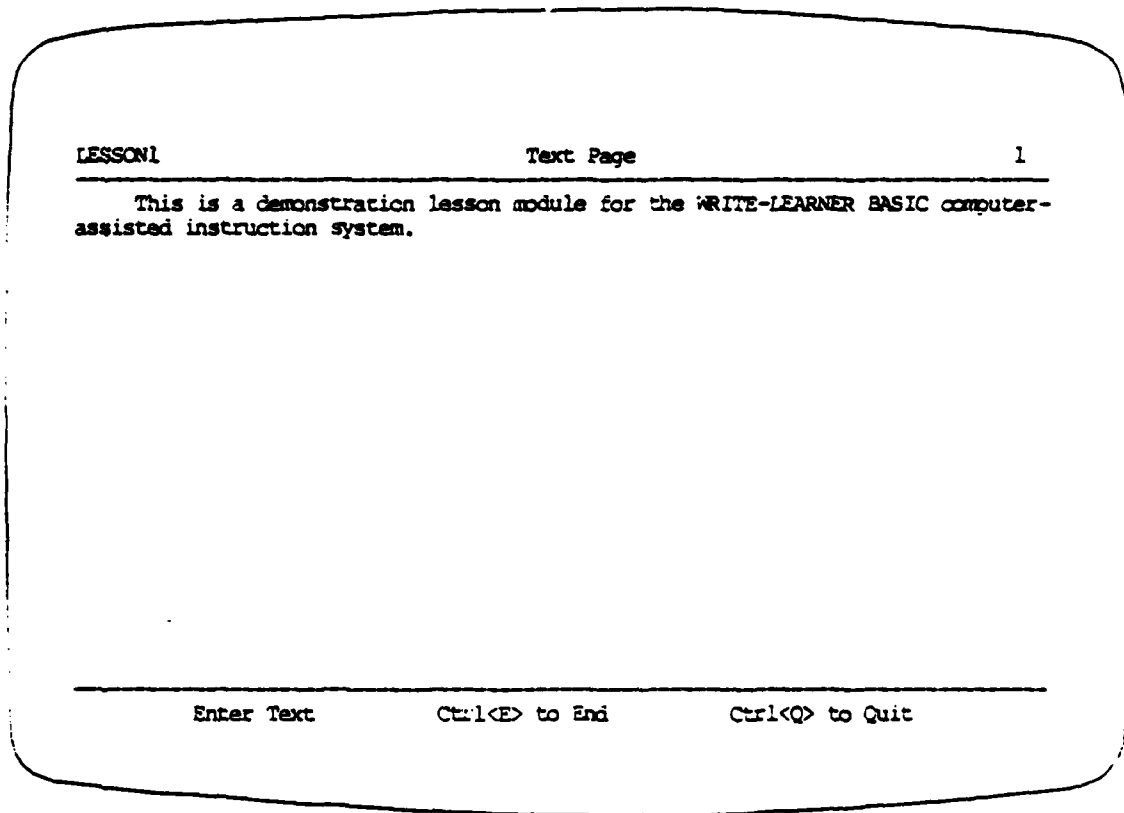

Input of a typical text page. Word wrap is automatic and current line can be corrected by backspacing. <CTRL><Q> erases entire page and returns to page number prompt. <CTRL><E> ends page input.

Figure E.2: Creating a Lesson File with WRITE/BAS
(continued)

LESSON1

Text Page

1

This is a demonstration lesson module for the WRITE-LEARNER BASIC computer-assisted instruction system.

Jump-to page:

Enter requested data and press <ENTER> to continue.

Input of jump-to page following <CTRL><E> input during text entry. Jump-to page number is validated for being within legal limits.

Figure E.2: Creating a Lesson File with WRITE/BAS
(continued)

This is a demonstration lesson module for the WRITE-LEARNER BASIC computer-assisted instruction system. What type of page is this?

- <A> Multiple choice question page.
- Text page.
- <C> True/false question page.
- <D> blank page.
- <E> None of the above.

Correct answer: A
A-jump page : 40
B-jump page : 30
C-jump page : 30
D-jump page : 30
E-jump page : 30

Enter requested data and press <ENTER> to continue.

Input of correct answer and jump-to pages following <CTRL><E> input during multiple-choice question screen text entry. Correct answer is single letter key (A-E) input.

Figure E.2: Creating a Lesson File with WRITE/BAS
(continued)

This is a demonstration lesson module for the WRITE-LEARNER BASIC computer-assisted instruction system. True/False: This page is a true/false question page.

<T> True.
<F> False.

Correct answer: T
T-jump page : 50
F-jump page : 40

Enter requested data and press <ENTER> to continue.

Input of correct answer and jump-to pages following <CTRL><E> input during true/false question screen text entry. Correct answer is single letter key (T/F) input. .

Figure E.2: Creating a Lesson File with WRITE/BAS
(continued)

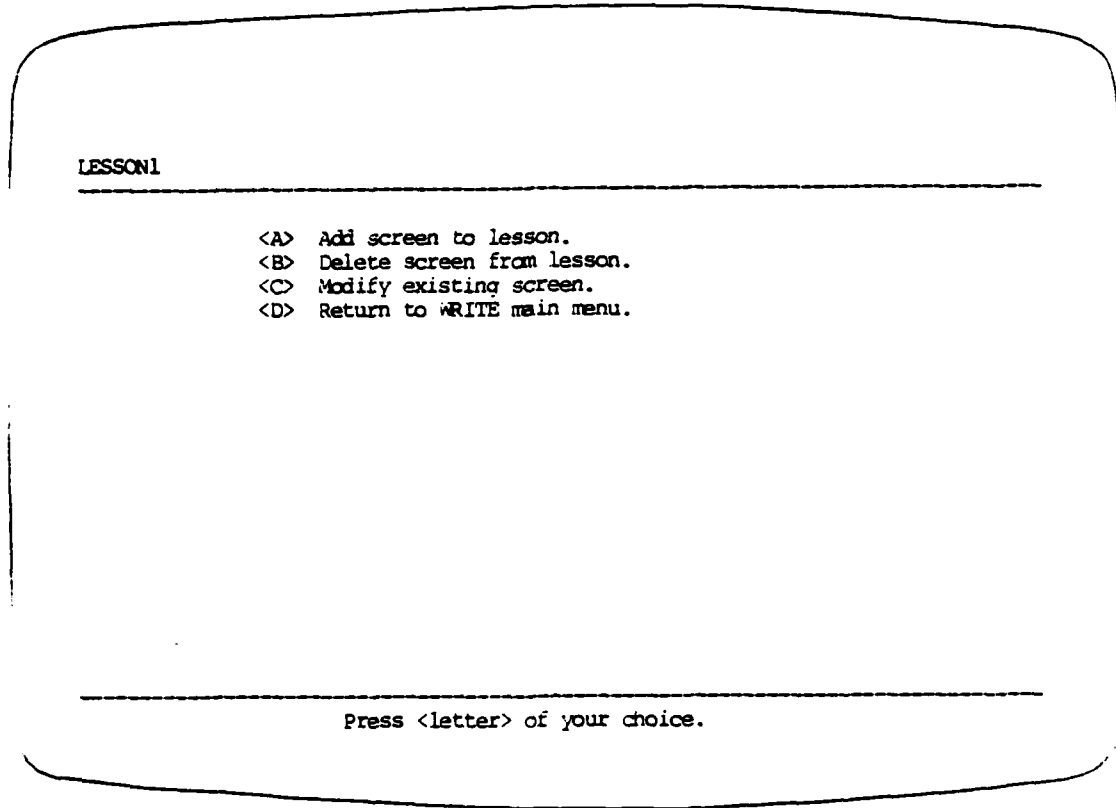

WRITE/BAS edit menu and input of desired function.

Figure E.3: Editing a Lesson File with WRITE/BAS

This is a demonstration lesson module for the WRITE-LEARNER BASIC computer-assisted instruction system. What type of page is this?

- <A> Multiple choice question page.
- Text page.
- <C> True/false question page.
- <D> Blank page.
- <E> None of the above.

<D> to Delete Page

<Q> to Abort

Display of page to delete following page number input and input of delete decision.

Figure E.3: Editing a Lesson File with WRITE/BAS
(continued)

This is a demonstration lesson module for the WRITE-LEARNER BASIC computer-assisted instruction system. True/False: This page is a true/false question page.

<T> True.
<F> False.

Ctrl <E>nd text edit Ctrl <Q>uit and cancel Ctrl <D>elete character

Display of page to modify following page number input. Arrow keys move cursor within limits of current page. Overstriking or deleting of characters is allowed.

Figure E.3: Editing a Lesson File with WRITE/BAS
(continued)

This is a demonstration lesson module for the WRITE-LEARNER BASIC computer-assisted instruction system. True/False: This page is a true/false question page.

- <T> True.
- <F> False.

Page number: 40

Change page number? <Y>es <N>o

Changing lesson screen page number following
<CTRL><E> input during text editing.

Figure E.3: Editing a Lesson File with WRITE/BAS
(continued)

This is a demonstration lesson module for the WRITE-LEARNER BASIC computer-assisted instruction system. True/False: This page is a true/false question page.

- <T> True.
- <F> False.

Correct answer: T

Change correct answer?

<Y>es

<N>o

Changing correct answer for multiple-choice or true/false question page.

Figure E.3: Editing a Lesson File with WRITE/BAS
(continued)

LESSON1

MODIFY A PAGE

40

This is a demonstration lesson module for the WRITE-LEARNER BASIC computer-assisted instruction system. True/False: This page is a true/false question page.

<T> True.
<F> False.

TJUMP: 50

FJUMP: 40

Change answer jump pages?

<Y>es

<N>o

Changing jump-to page numbers.

Figure E.3: Editing a Lesson File with WRITE/BAS
(continued)

LESSON1

MODIFY A PAGE

40

This is a demonstration lesson module for the WRITE-LEARNER BASIC computer-assisted instruction system. True/False: This page is a true/false question page.

<T> True.
<F> False.

TJUMP: 50

FJUMP: 40

Which one?

Press <letter> of your choice.

Changing jump-to page numbers.

Figure E.3: Editing a Lesson File with WRITE/BAS
(continued)

PRINT A LESSON FILE

Enter lesson name (maximum of 8 characters; do not include extension; <ENTER> to abort):

Enter requested data and press <ENTER> to continue.

Input of lesson name to print. The screen for printing a student file report is similar.

Figure E.4: Printing a Lesson File with WRITE/BAS

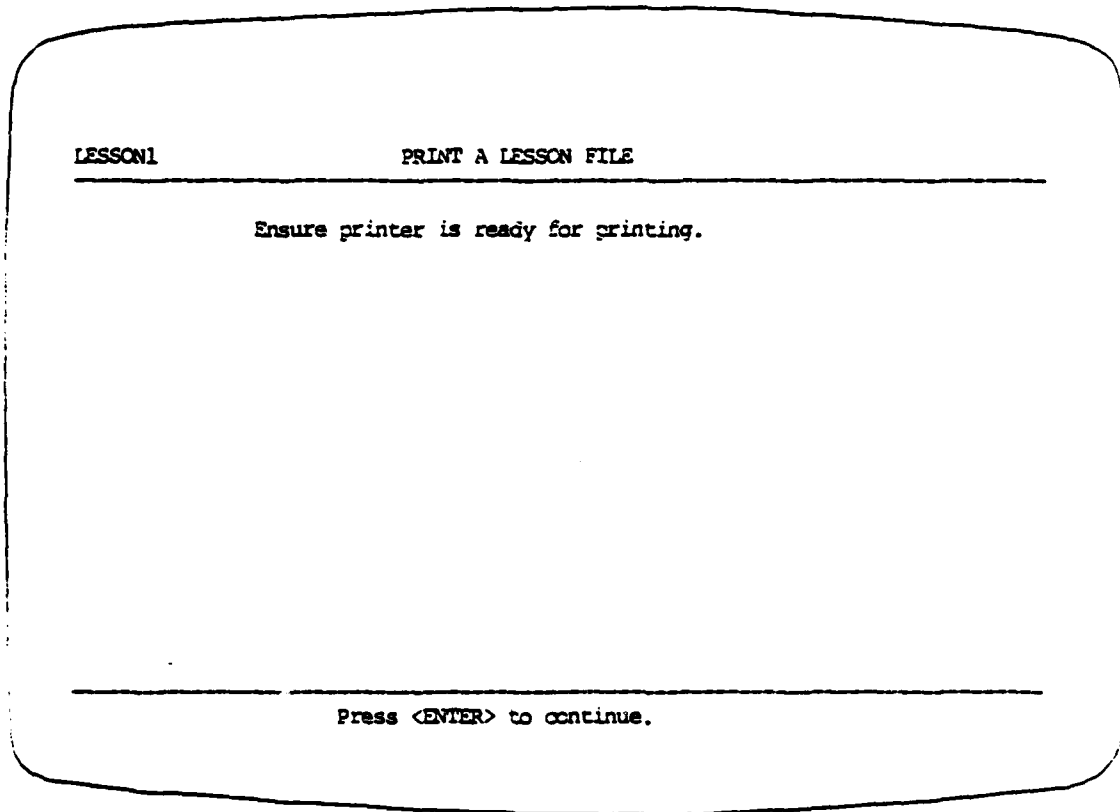

Printer instructions for printing a lesson file. The screen for printing a student file report is similar.

Figure E.4: Printing a Lesson File with WRITE/BAS (continued)

Page = 1

Welcome to the LEARNER computer-assisted instruction program introduction. This is an introductory lesson to provide practice with the computer program before using actual lesson material.

Look at the bottom line of this screen. It tells you to press the <ENTER> key to continue. Each screen of the lesson will remain on the screen until you take the action described on the bottom line of the screen. Don't worry about pressing the wrong key - the computer will not respond until you press one of the allowable keys.

Some computers do not have an <ENTER> key, but have a similar key that performs the same function. This key is the same as the <RETURN> key on a typewriter and should be used whenever you are requested to press the <ENTER> key.

Now let's continue with the rest of this introductory lesson. Look at the bottom line of the screen and press the proper key to continue.

Jump: 10

Page # 10

Good...you understand how to continue the lesson from a page of text!

The screen you are reading and the previous screen are examples of text screens. Text screens will give you factual information about the lesson subject. You should read these pages carefully and attempt to remember the important information. You should not spend too much time on each page trying to memorize each line. Computer-assisted instruction should be fun. Read the material and continue each screen at a comfortable pace. The program will ensure that you have an adequate grasp of the subject material before continuing the lesson.

Now look at the top line of the screen. On the left you will see the title of the lesson you are running. This title is up to eight characters which is the name of the files on the disk. On the right is the screen number of the screen you are reading. Do not worry if these screen numbers do not come in order or jump around. These numbers are used for lesson branching and are simply a reference number for you and the lesson author.

(Before pressing the <ENTER> key to continue this lesson, try pressing other keys to see what effect they have on the computer.)

Jump: 20

Page # 20

Figure E.5: Sample of Printed Lesson File

see? Pressing the wrong key has no effect on the computer program. You cannot damage the program, the computer, or the lesson material by pressing the wrong key on the computer.

Jump: 30

Page # 30 / Question # 1

This screen is a sample of a multiple choice question. Look at the instruction line. It no longer says press the <ENTER> key to continue. Instead, you should press the letter key of your answer choice. Do not press the <ENTER> key after the letter key. Press only the letter key of your answer choice. Also, look at the top line of the screen. The number of this question is displayed on this line as well as the lesson title and screen number. Now the question...

If you press the <ENTER> key now, what effect would this have on the computer?

- <A> No effect - it's not one of the allowable keys on the instruction line.
- The computer would probably break.
- <C> The training supervisor would get very angry.
- <D> All the computer disks would be erased.
- <E> The computer program would be destroyed.

A-jump: 50 B-jump: 40 C-jump= 40 D-jump: 40 E-jump: 40 Correct: A

Page # 40

No...remember pressing a key not allowed has no effect on the computer. You cannot damage the computer, the disks, or programs by pressing the wrong key during lesson execution.

Jump: 50

Page # 50

The correct answer was <A>, of course. Multiple choice questions are one of two types of questions you will encounter during lessons. Remember, press only the <letter> key of your answer choice and do not press the <ENTER> key after the <letter> key. If the computer does not seem to respond to your entry, check the <CAPS LOCK> key to ensure that it is depressed. This program will accept only capital letter input during the lesson.

Figure E.5: Sample of Printed Lesson File (continued)

Jump: 60

Page # 60 Question # 2

This screen is an example of a true/false question. Notice that the allowable letter keys have changed. Now you must press the <T> or <F> key to select your answer. Again, do not press the <ENTER> key after your response. Press only the letter key of your answer.

True/False: To respond with true to a true/false question, you should press the <A> key.

<T>true
<F>alse

T-jump: 70 F-jump: 70

Correct: F

Page # 70

The answer, of course, is false. For true/false questions, the allowable answer keys are <T> and <F>.

Okay, so the program has you read material and answer questions. So what? Well, based on your answers to the various questions, the computer will display different screens. If you get an answer wrong, the computer will probably repeat a page of text or provide you with a new page of text to ensure that you understand the material before proceeding. Pretty neat, huh? Remember, computer assisted-instruction should be fun!

Jump: 80

Page # 90

This completes the introductory lesson to the LEARNER computer-assisted instruction system. You should also read the LEARNER User's Guide for additional information on the computer and this program.

Press <ENTER> now to return to the LEARNER Main Menu.

Jump: 9999

Figure E.5: Sample of Printed Lesson File (continued)

INTRO STUDENT FILE REPORT

07/15/87

STUDENT NAME/DATE	ASKED	RIGHT	WRONG	PCT	WRONG QUESTIONS-RESPONSES
JPERRY 07/15/87	2	2	0	100.0	
OSMITH 07/15/87	2	1	1	50.0	1-E
SMASON 07/15/87	2	1	1	50.0	2-T
DMURPHY 07/15/87	2	0	2	0.0	1-E 2-T

Figure E.6: Sample of Printed Student File Report

Appendix F: WRITE/BAS User's Guide

Contents

	Page
Introduction.	F- 2
Notes for Courseware Administrators	F- 4
Getting Started	F- 6
Creating a Lesson File.	F- 7
Editing a Lesson File	F- 9
Printing Lesson File and Student File Reports	F-11
Lesson File Problems.	F-12
Error Messages.	F-13

Introduction

WRITE/BAS is a program written in the BASIC programming language which is one component of the WRITE-LEARNER computer-assisted instruction system. WRITE will enable you to create interactive, computer-assisted instruction courseware to be administered with the LEARNER/BAS program. This user's guide is intended to provide the knowledge required to use the WRITE program with a minimum of computer knowledge.

The courseware you develop can consist of up to 200 lesson screens consisting of three different types of pages or screens. Text pages contain up to twenty lines of text to present information to the student. Multiple-choice question pages consist of a question and five (letters A-E) allowable question responses. True/false question pages consist of a statement with two allowable question responses (T/F). Each page also has an appropriate number of jump pages to permit variable lesson branching. For example, an incorrect response to a multiple choice question page may branch to a series of text pages containing remedial or amplified information about the subject area while a correct response skips this supplemental information. You should note that a "lesson" can consist only of question pages and can therefore be used as a test generator.

Question responses must be entered as text lines on the screen. Responses to multiple choice questions must be

entered as "<A> answer response". The allowable responses to true/false questions should be entered as "<T>rue/<F>alse". The "< >" symbol (indicating a keyboard key) around the allowable responses is to maintain consistency with the remainder of the program. You should run the introductory lesson of LEARNER/BAS for formats of text, multiple-choice question, and true/false question screens.

Notes for Courseware Administrators

This user's guide was developed primarily for use with a Tandy-Radio Shack Model IV or Zenith Z-248 microcomputer system. With the wide diversity of MS-DOS and TRSDOS computers available and the diversity of operating systems and disk-operating system "shells" in use, an "all-encompassing" user's guide for this system is not practicable. This guide is being copied (as written) in ASCII format on the WRITE-LEARNER distribution disk. Courseware administrators will use this guide to develop local instructions depending on computers available and operating systems in use. Also, the use of job control language files (Model IV) or auto-batch command files (MS-DOS) to start the program is encouraged.

The user may require some BASIC programming knowledge depending on local computer configuration. The WRITE program is configured to operate with the system disk on a disk drive designated drive 1 (TRS-DOS) or A (MS-DOS). If the local computer configuration does not permit this, lines 1550, 1555, and 1560 will require modification to designate the proper drive.

Another problem may exist if numerous pages are deleted from a lesson file. WRITE/BAS does not delete records from the lesson text file but rather fills the records with "*" characters. This may lead to excessively long text files. Due to the large numbers of computer

configurations available, deleting these records and collapsing the text file is not accomplished by this program. Consult a BASIC programmer to develop a utility to accomplish this task. In general, the procedure is to read a number of records from the text file into memory and then write the records not flagged for deletion to a new text file. Following this procedure, a new lesson table file must be created by entering the WRITE/BAS lesson editing module and immediately selecting the exit editor option. This procedure forces recreation of the lesson table file.

In the event that a lesson text file exists on a disk without the corresponding lesson table file (due to data loss or erroneous disk copying) the WRITE/BAS editing module will return an error message. To recover from this error, copy any lesson table file to the disk (such as the LEARNER/BAS introduction lesson table file, INTRO/TAB) to the required disk. Rename the file from "INTRO/TAB" to "<Lesson Filename>/TAB". Enter the WRITE/BAS editing module and immediately select the exit editor option. This procedure forces recreation of the lesson table file. The lesson text file can then be edited or used in a normal manner.

Getting Started

WRITE/BAS operates under the BASIC programming language using data disks from the WRITE-LEARNER package and locally developed courseware data disks. To start the WRITE program, take the following actions:

- Step 1 Turn on the computer and monitor.
- Step 2 Load BASIC into the computer. On AFIT Z-248's, this is accomplished by pressing the key while at the main menu display. On the Model IV, type "BASIC <ENTER>" at the DOS ready prompt.
- Step 3 Insert the WRITE-LEARNER system disk in drive A (Z-248) or drive 1 (Model IV).
- Step 4 Depending on computer configuration, type one of the following line exactly as it appears then press the <ENTER> key:

```
    RUN "A:WRITE.BAS" (Z-248)  
    RUN "WRITE/BAS:1" (Model IV)
```
- Step 5 The WRITE main menu will be displayed at this point. Select the option of your choice and press the corresponding <letter> key. Do not press the <ENTER> key after your selection; press only the <letter> key.
- Step 6 Note that option <E> on the WRITE main menu ends the program. This is the normal termination procedure for this program. Pressing the <E> key will return the computer to the DOS ready prompt.

Creating a Lesson File

To create a new lesson file, take the following actions:

- Step 1 Select <A> at the WRITE main menu.
- Step 2 Insert a properly formatted (recommend a newly formatted disk) in the disk drive when directed.
- Step 3 Enter the lesson filename when directed.
- Step 4 Enter the page number when directed. Page numbers must be between 1 and 9998. The first page of a lesson must be page 1! The program will not allow you to duplicate page numbers.
- Step 5 Select the type of page to enter and press the corresponding <letter> key.
- Step 6 The lesson name, page type, and page number will be displayed on the top line of the screen. You are now in the screen entry mode. Enter up to 20 lines of text as you want it to appear in the lesson. In this mode, word wrap is automatic (i.e., when you continue past the end of a line, the line will be broken at the last space, dash, or slash and the remainder of the line moved to the next text line. The following special keys are available in the screen entry mode:

<BACKSPACE> or <left arrow>: Permits correction of the current line only. Backspaces the cursor and erases any text under the cursor.

<TAB> or <right arrow>: Tabs the cursor 5 spaces; does not function if insufficient room remains on the current line to tab.

<ENTER>: Terminates entry of the current line and moves the cursor to the next line.

<CTRL> and <E> (pressed together): Terminates entry of the current page and requests additional information about the page.

<CTRL> and <Q> (pressed together): Quits entry of the current page without saving! Use to totally erase a page and start over.

Step 7 After pressing <CTRL><E> to end page input, additional data will be requested on the lower 5 lines of the text page. If you have used the full page, some of these text lines will be erased from the screen but are still in the lesson. The lines are erased only to provide room to enter the additional data. Enter the additional data in accordance with the prompts. For correct answer prompts, press only the <letter> key of the correct response (i.e., A-E for multiple choice questions or T/F for true/false questions). Jump pages are the corresponding page of the lesson that will be displayed next depending on the student's answer. Jump pages must be between 1 and 9999 and need not have been already entered to use. A jump page of 9999 will terminate lesson execution when run in the LEARNER program.

Step 8 To terminate lesson input, enter a page number of 9999 when requested. This action will terminate the create lesson module of the program, generate the required files on the disk and return to the WRITE main menu.

Editing a Lesson File

To edit an existing lesson file, take the following actions:

NOTE: To edit a lesson file, the text file and table file must be on the same disk! If you copy a lesson file from one disk to another, ensure that both files are copied!

- Step 1 Select at the WRITE main menu.
- Step 2 Insert the disk containing the lesson files in the disk drive when directed.
- Step 3 Enter the lesson filename when directed.
- Step 4 Select the edit action desired and press the corresponding <letter> key.
- Step 5 Selecting <A> to add page(s) to the lesson enters the same module as creating a lesson file. Add pages to the lesson in accordance with the above instructions. To exit adding pages to the lesson, enter a page number of 9999 when requested. This action will return to the edit menu.
- Step 6 Selecting to delete a page will display the selected page to ensure that you want to delete that page. Press <D> to delete the page or <Q> to return to the edit menu without deleting the page.
- Step 7 Selecting <C> to modify a page will display the selected page and enter a full screen editing mode. This is a limited full screen editor intended to make minor corrections to an existing page. Lines cannot be added to the screen! If major modifications are required, delete the page using the option then add the same numbered page using the <A> option. The following special keys are available in the screen edit mode:

<arrow> keys: Move the cursor around the screen within the confines of the existing page (i.e., you cannot move down past the current last line).

<CTRL> and <D> (pressed together) or <BACKSPACE> or <DELETE>: Deletes the character under the cursor.

<valid ASCII> keys: Replaces the character under the cursor with the input key.

<CTRL> and <Q> (pressed together): Quits the editor without saving any changes to the page.

<CTRL> and <E> (pressed together): Ends text editing and displays additional information to be changed. Answer the prompts by pressing the appropriate <letter> key.

Step 8 Selecting <D> ends lesson editing, updates appropriate files on the disk, and returns to the WRITE main menu.

Printing Lesson Files and Student File Reports

Lesson files and student files can be printed in a formatted manner on any available printer. Select these options at the WRITE main menu and follow the computer prompts to print these files.

Lesson File Problems

This checklist is provided for checking a lesson file printed copy. Use this checklist to verify lesson operation or to identify problems.

- Step 1 A page numbered 1 must exist in each lesson.
- Step 2 A text page cannot jump to itself and all answer jumps of a question cannot jump to itself (i.e., never-ending loop created).
- Step 3 A valid numbered page must exist for all jump pages except 9999.
- Step 4 All branches through a lesson must end with a jump to page 9999 (terminates lesson execution). Recommend that the last page of a lesson be a text page with a jump page of 9999.

Error Messages

As with any computer program, every precaution has been taken to ensure that the program is error free; however, unforeseen errors may occur. In the event that an error occurs, an error message will appear on the screen. Pressing <ENTER> will close all open files and return to the WRITE main menu. You should select the edit option and immediately end editing (option <D>) to force recreation of the lesson table file. Data may be lost depending on the error. Refer to the appropriate BASIC reference for translation of error codes.

Bibliography

1. Bahniuk, Dr. Margaret. "The Value in Computer-Based Training," Office Administration and Automation, 45 (8): 85 (August 1984).
2. Bork, Alfred. Personal Computers for Education. New York NY: Harper & Row, Publishers, Inc., 1985.
3. Boyd, Warren A. and John R. Eldridge. "Beyond User Friendly," Training and Development Journal, 38 (12): 36-8 (December 1984).
4. Burlage, John. "Carrier America Keeps Parts Problems in Check," Navy Times, 36 (4): 4 (November 10, 1986).
5. ----- . "Navy Plans Longer Sea Tours for Some AK's," Navy Times, 36 (2): 2 (October 27, 1986).
6. ----- . "AK Shortage Cited in Parts Tracking Ills," Navy Times, 36 (1): 1+ (October 20, 1986).
7. ----- . "Audit Hits Supply Practices, But Praises Corrective Steps," Navy Times, 35 (52): 4 (October 13, 1986).
8. Fauley, Franz E. "The New Training Technologies: Their Rocky Road to Acceptance," Training and Development Journal, 37 (12): 22-5 (December 1983).
9. ----- . "Computer Based Education," Training and Development Journal, 34 (11): 20-1 (November 1980).
10. General Accounting Office. Navy's Progress in Improving Physical Inventory Controls and the Magnitude, Causes, and Impact of Inventory Record Inaccuracies in the Army, Air Force, and Defense Logistics Agency. GAO/NSIAD-84-9. Gaithersburg MD, November 4, 1983.
11. Govaerts, Kenneth C. and Thomas A. Grillot. "Computer-Based Industrial Training: A Primer," Training and Development Journal, 38 (11): 28-31 (November 1984).
12. Hillelsohn, Michael J. "How to Think About CBT," Training and Development Journal, 38 (12): 42-4 (December 1984).
13. Kearsley, . and Michael J. Hillelsohn. "How and Why (And Why Not) We Use Computer-Based Training," Training and Development Journal, 38 (1): 21-2+ (January 1984).

14. Kindel, Stephen and Ellen Benoit. "Hello, Mr. Chip," Forbes, 133 (9): 132+ (April 23, 1984).
15. Naval Supply Systems Command. Naval Aviation Supply Officer Program. NAVSUP Publication 550. Washington DC, 30 November 1984.
16. Noel, Jr., John V. and Frank E. Bassett. Division Officer's Guide (Second Edition). Annapolis MD: Naval Institute Press, 1976.
17. "Over the Side," Time, 126 (5): 18 (August 5, 1985).
18. Radio Shack Disk System Owner's Manual, TRS-80, Model 4. Fort Worth TX: Tandy Corporation, 1983.
19. Reynolds, Angus. "An Introduction to Computer-Based Learning," Training and Development Journal, 37 (5): 34-8 (May 1983).
20. Reynolds, Angus and Richard Davis. "The Five Most Frequent Questions (Plus One) About Computer-Based Learning," Training and Development Journal, 37 (5): 42+ (May 1983).
21. Tonkin, Bruce. "Choose Your Weapon: Basic, Pascal, or C," 80Micro, 84: 96+ (January 1987).
22. Walker, Decker F. "Reflections on the Educational Potential and Limitations of Microcomputers," Introduction to Microcomputer Applications in Education, edited by Lonnie J. Echternacht and others. Columbia MO: Instructional Materials Laboratory, University of Missouri-Columbia, 1984.

VITA

Lieutenant Robert Mason was born on 15 July 1952 in Dallas, Texas. He graduated from high school in Richmond, Virginia in 1970 and enlisted in the U. S. Navy in November of that year. He was selected for the Navy Enlisted Scientific Education Program (NESEP) in 1974 and attended Auburn University from which he received the degree of Bachelor of Science in Aerospace Engineering in 1978. He was concurrently commissioned as a Naval Supply Officer. He subsequently served as Supply Officer of USS NATHAN HALE (SSBN-623)(GOLD); Aviation Support Officer at Naval Air Station, Key West, Florida; and Aviation Support Officer of USS AMERICA (CV-66). Lieutenant Mason holds warfare qualifications as Submarine Supply Officer and Naval Aviation Supply Officer. He entered the School of Systems and Logistics, Air Force Institute of Technology, in May 1986. He is married to the former Roberta Lynn Johnson of Richmond, Virginia, and has three daughters.

Permanent address: 721 Sunburst Lane
Dallas, Texas 75218

REPORT DOCUMENTATION PAGE

Form Approved
OMB No. 0704-0188

1a. REPORT SECURITY CLASSIFICATION UNCLASSIFIED		1b. RESTRICTIVE MARKINGS	
2a. SECURITY CLASSIFICATION AUTHORITY		3. DISTRIBUTION/AVAILABILITY OF REPORT Approved for public release; distribution unlimited.	
2b. DECLASSIFICATION/DOWNGRADING SCHEDULE			
4. PERFORMING ORGANIZATION REPORT NUMBER(S) AFIT/GLM/LSR/87S-45		5. MONITORING ORGANIZATION REPORT NUMBER(S)	
6a. NAME OF PERFORMING ORGANIZATION School of Systems and Logistics	6b. OFFICE SYMBOL (if applicable) AFIT/LSM	7a. NAME OF MONITORING ORGANIZATION	
6c. ADDRESS (City, State, and ZIP Code) Air Force Institute of Technology Wright-Patterson AFB OH 45433-6583		7b. ADDRESS (City, State, and ZIP Code)	
8a. NAME OF FUNDING/SPONSORING ORGANIZATION	8b. OFFICE SYMBOL (if applicable)	9. PROCUREMENT INSTRUMENT IDENTIFICATION NUMBER	
8c. ADDRESS (City, State, and ZIP Code)		10. SOURCE OF FUNDING NUMBERS	
		PROGRAM ELEMENT NO.	PROJECT NO.
		TASK NO.	WORK UNIT ACCESSION NO.
11. TITLE (Include Security Classification) See Box 19			
12. PERSONAL AUTHOR(S) Robert Mason, B.S., LT, SC, USN			
13a. TYPE OF REPORT MS Thesis	13b. TIME COVERED FROM _____ TO _____	14. DATE OF REPORT (Year, Month, Day) 1987 September	15. PAGE COUNT 234
16. SUPPLEMENTARY NOTATION			
17. COSATI CODES		18. SUBJECT TERMS (Continue on reverse if necessary and identify by block number)	
FIELD	GROUP	SUB-GROUP	
05	12		
06	05		
		Computer-assisted Instruction, Training, Supply, Navy	
19. ABSTRACT (Continue on reverse if necessary and identify by block number)			
Title: A GENERAL APPLICATION COMPUTER-ASSISTED INSTRUCTION SYSTEM FOR MICROCOMPUTERS			
Thesis Chairman: John A. Stibravy, Major, USAF Associate Professor of Technical Communications			
20. DISTRIBUTION/AVAILABILITY OF ABSTRACT <input checked="" type="checkbox"/> UNCLASSIFIED/UNLIMITED <input type="checkbox"/> SAME AS RPT. <input type="checkbox"/> DTIC USERS		21. ABSTRACT SECURITY CLASSIFICATION UNCLASSIFIED	
22a. NAME OF RESPONSIBLE INDIVIDUAL John A. Stibravy, Major, USAF		22b. TELEPHONE (Include Area Code) (513) 255-6761	22c. OFFICE SYMBOL AFIT/LSR

Approved for public release
by E. W. [Signature]
Declassify on:
Air Force [Signature]
Weight-restricted [Signature]

24 Sep 87

UNCLASSIFIED

Block 19.

This study provides supply managers with an alternate method of augmenting Naval aviation storekeeper training to improve supply support management at operating sites. A microcomputer-based computer-assisted instruction system was developed which has much broader and significant application. The system can be used in any subject area to develop, administer, and monitor training and is applicable to all Navy, Air Force, Army, and other Department of Defense components. The potential for cost savings and improved operational capability through the use of this system is unlimited.

The system consists of two computer programs written in the BASIC programming language, program documentation, and a user's guide for the system. The system was developed on a Radio Shack, TRS-80, Model 4 microcomputer and converted to operate on a Zenith, Z-248, IBM-AT/PC compatible microcomputer.

The system creates and administers interactive computer-assisted instruction lessons consisting of up to 200 text, multiple choice question, and true/false question screens. Variable branching is allowed from question pages depending on student answer input.

LEARNER/BAS displays course material to the student. The program requires single key input by the student at the end of each screen. On completion of each lesson, the program records data to a disk file for analysis and lesson improvement.

WRITE/BAS generates the text and branching table files for use with LEARNER/BAS. A courseware author can create new lesson files, edit existing lesson files, print lesson files, and print student file reports.

Program documentation is complete so as to allow modifications and enhancements by the user (BASIC programming ability required) based on unique requirements or desires. The user's guide, although short, is complete and reflects the ease of program use.

END

DATE

FILMED

FEB.

1988