

MICROCOPY RESOLUTION TEST CHART
NATIONAL BUREAU OF STANDARDS 1963-A

DTIC FILE COPY

RSMAS TR-87-006

GAL Report #1004

Copy No. 100

AD-A187 404

A DEEP-WATER OBS ARRAY WITH REAL-TIME TELEMETRY

C.E. Abbott
T. Yamamoto
M. Badiey
A. Turgut

Geo-Acoustic Laboratory
Division of Applied Marine Physics and
Ocean Engineering
Rosenstiel School of Marine and Atmospheric Science
University of Miami

October, 1987

Approved for Public Release;
distribution unlimited

DTIC

ELECTE

NOV 25 1987

prepared for:

OFFICE OF NAVAL RESEARCH
DEPARTMENT OF THE NAVY
ARLINGTON, VA 22217

87 11 10 049

Unclassified

SECURITY CLASSIFICATION OF THIS PAGE

AD-1111/120

Form Approved
OMB No. 0704-0188
Exp. Date: Jun 30, 1986

REPORT DOCUMENTATION PAGE

1a. REPORT SECURITY CLASSIFICATION Unclassified		1b. RESTRICTIVE MARKINGS	
2a. SECURITY CLASSIFICATION AUTHORITY		3. DISTRIBUTION/AVAILABILITY OF REPORT Public Release/Unlimited	
2b. DECLASSIFICATION/DOWNGRADING SCHEDULE		5. MONITORING ORGANIZATION REPORT NUMBER(S)	
4. PERFORMING ORGANIZATION REPORT NUMBER(S)		7a. NAME OF MONITORING ORGANIZATION Office of Naval Research	
6a. NAME OF PERFORMING ORGANIZATION Div. of Applied Marine Physics University of Miami, RSMAS	6b. OFFICE SYMBOL (if applicable)	7b. ADDRESS (City, State, and ZIP Code) Department of the Navy Arlington, VA 22217	
6c. ADDRESS (City, State, and ZIP Code) 4600 Rickenbacker Causeway Miami, Florida 33149		9. PROCUREMENT INSTRUMENT IDENTIFICATION NUMBER N00014-87-G-0116	
8a. NAME OF FUNDING/SPONSORING ORGANIZATION Office of Naval Research	8b. OFFICE SYMBOL (if applicable) ONR	10. SOURCE OF FUNDING NUMBERS	
8c. ADDRESS (City, State, and ZIP Code) Department of the Navy Arlington, VA 22217		PROGRAM ELEMENT NO.	PROJECT NO.
11. TITLE (Include Security Classification) A Deep-Water Array with Real-Time Telemetry		TASK NO.	WORK UNIT ACCESSION NO.
12. PERSONAL AUTHOR(S) Charles Abbott, Tokuo Yamamoto, Mohsen Badiey, Altan Turgut			
13a. TYPE OF REPORT Interim	13b. TIME COVERED FROM _____ TO _____	14. DATE OF REPORT (Year, Month, Day) October 1987	15. PAGE COUNT 28
16. SUPPLEMENTARY NOTATION The views, opinions, and/or findings contained in this report are those of the authors and should not be construed as official Department of the Navy policy.			
17. COSATI CODES		18. SUBJECT TERMS (Continue on reverse if necessary and identify by block number)	
FIELD	GROUP	SUB-GROUP	
19. ABSTRACT (Continue on reverse if necessary and identify by block number) A two-element, ocean bottom seismometer (OBS) array, operating in the ULF/VLF range, has been developed for use at depths to 2000 meters and inter-element spacing to 600 meters. Seismic periods between 1 and 200 seconds, accelerations of 10^{-7} m/sec ² , and pressure fluctuations of 1 pascal are within the system sensing limits. As such, investigations related to ambient ocean noise and low frequency ARI are possible. The array incorporates real-time radio telemetry to provide a user with on-site, quick-look capability while eliminating ship tending and/or anchoring constraints. The array features rapid deployment and retrieval and observational periods of 5 days before recharging the buoy batteries. Total length of array cable is 3020 m. Each element of the array is composed of: a three axis set of medium-period (continued)			
20. DISTRIBUTION/AVAILABILITY OF ABSTRACT <input checked="" type="checkbox"/> UNCLASSIFIED/UNLIMITED <input type="checkbox"/> SAME AS RPT <input type="checkbox"/> DTIC USERS		21. ABSTRACT SECURITY CLASSIFICATION	
22a. NAME OF RESPONSIBLE INDIVIDUAL Tokuo Yamamoto		22b. TELEPHONE (Include Area Code) (305) 361-4637	22c. OFFICE SYMBOL

SECURITY CLASSIFICATION OF THIS PAGE

seismometers, a differential pressure gauge and, to determine package orientation, two inclinometers and a north-seeker. All sensor signals are digitized within the under-water package and a single, coaxial mooring cable couples the seismic data from each element to a surface telemetry buoy where it is relayed, via radio frequency, to a shipboard receiver for immediate storage and real-time analysis.

This report describes the system components, characteristics, and specifications.



Accession For	
NTIS GRA&I	<input checked="" type="checkbox"/>
DTIC TAB	<input type="checkbox"/>
Unannounced	<input type="checkbox"/>
Justification	
By _____	
Distribution/	
Availability Codes	
Avail and/or	
Dist	Special
A-1	

TABLE OF CONTENTS

ABSTRACT	i
LIST OF FIGURES	v
ACKNOWLEDGMENT	vi
I. BACKGROUND	1
II. SYSTEM OVERVIEW	2
III. SYSTEM COMPONENTS	2
IV. SUMMARY	17
REFERENCES	18
APPENDIX A: SYSTEM SPECIFICATIONS	19
APPENDIX B: MOORING CALCULATIONS	25

FIGURE CAPTIONS

- Fig. 1. Ocean bottom seismometer and pressure spectra measured in 76 meters of water on the New Jersey Shelf.
- Fig. 2. Transfer function (seismometer/pressure) and coherence spectra computed from the data in Figure 1.
- Fig. 3. Perspective view of a typical mooring system used in the deep-water array.
- Fig. 4. Plan view of the OBS package showing the two water-tight housings and the pressure sensor contained within the low-profile shroud.
- Fig. 5. Block diagram of the OBS electronic package.
- Fig. 6. Block diagram of the S-750 seismometer.
- Fig. 7. Differential pressure sensor.
- Fig. 8. Gain response of seismometer and pressure filters.
- Fig. 9. Phase response of seismometer and pressure filters.
- Fig. 10. Surface telemetry buoy.
- Fig. 11. Block diagram of telemetry buoy electronics.
- Fig. 12. Block diagram of receiving station electronics.

ACKNOWLEDGMENT

This work was supported under O.N.R. contract no. N00014-87-G-0116. (Dr. R. Fitzgerald, ONR Code #11250A). The authors would like to express their gratitude for Dr. Raymond Fitzgerald's support of this work.

We would also like to acknowledge Systems Planning and Analysis, Inc. (SPA) and specifically, James Dafoe, whose specifications "ULF/VLF PROGRAM SPECIFICATIONS", prepared for US Navy, served as our guide in developing this deep-water array.

One of the authors, Charles E. Abbott, is presently a consultant for Digital Liquid Systems, Inc. 6840 SW 76 Terrace, Miami, FL 33143.

BACKGROUND

Recent successes during OBS array experiments on the New Jersey Shelf¹, using newly developed seismometers and electronic instrumentation in 2 to 7-element arrays, have prompted the design and construction of a new array, deployable in deeper water than our previous designs².

Figures 1 and 2 illustrate typical real-time plots collected in shallow water during the New Jersey Shelf work in 76 meters of water. Fig. 1 is a graph of the power spectral densities measured by a vertical seismometer and simultaneously, by a differential pressure transducer (wave gauge) at the same location. The second graph, Fig. 2, displays the coherence and transfer function for the same two sensors. Quick-look plots, such as Figures 1 and 2 are particularly gratifying during the course of an experiment, both to confirm that the equipment is performing well and, in some instances, to modify the experimental design based on the field observations. Figures 1 and 2 were collected and plotted within hours after arriving on site.

Measurements of ambient ocean noise in the ULF/VLF band have many applications. At the University of Miami, results such as those in Fig. 1 and 2 are presently being analyzed^{3,4} according to the work of Yamamoto⁵, who by using an iterative "inversion" technique, has been able to, remotely and passively, describe the sheer modulus of the underlying sediment.

While the instrumentation performed well, some aspects of the design were not applicable to deeper water investigations. In shallow water it is a relatively simple procedure to deploy the OBS packages and maintain ship station with a 3-point anchoring system. The power and signal cable is then led over the side of the ship into a dry lab.

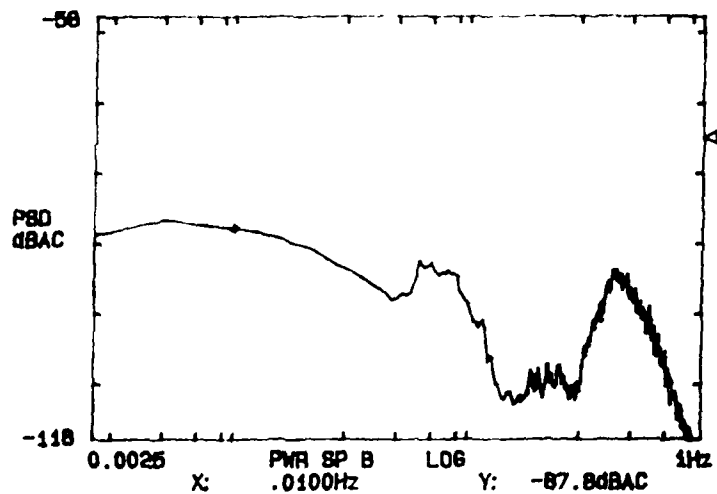
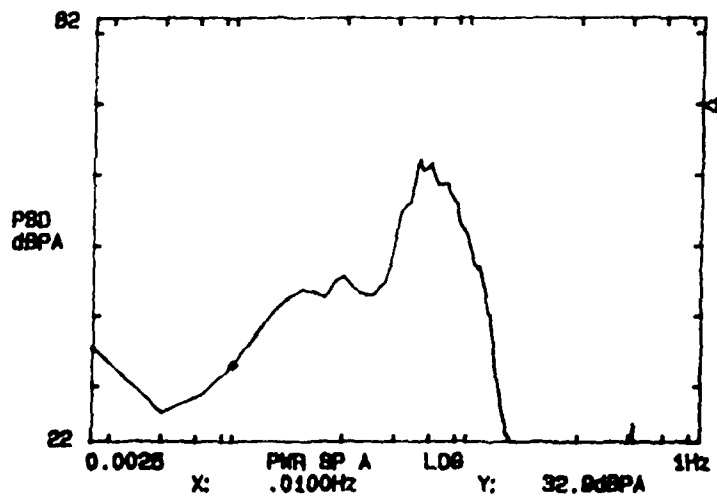

Fig. 1. Ocean bottom seismometer and pressure spectra measured in 76 meters of water on the New Jersey Shelf.



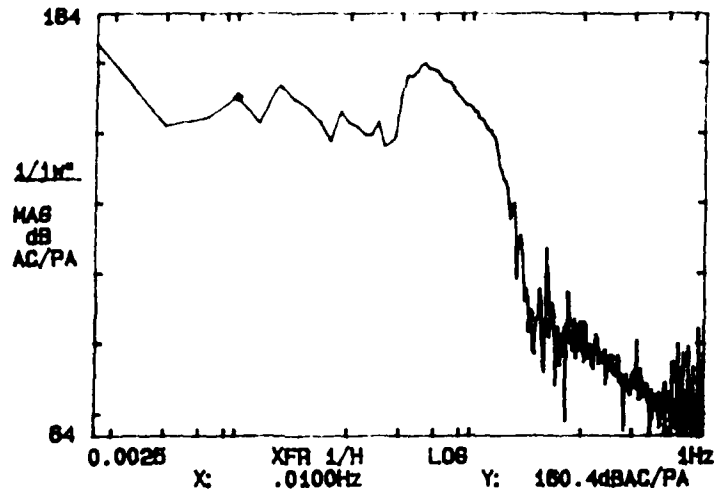
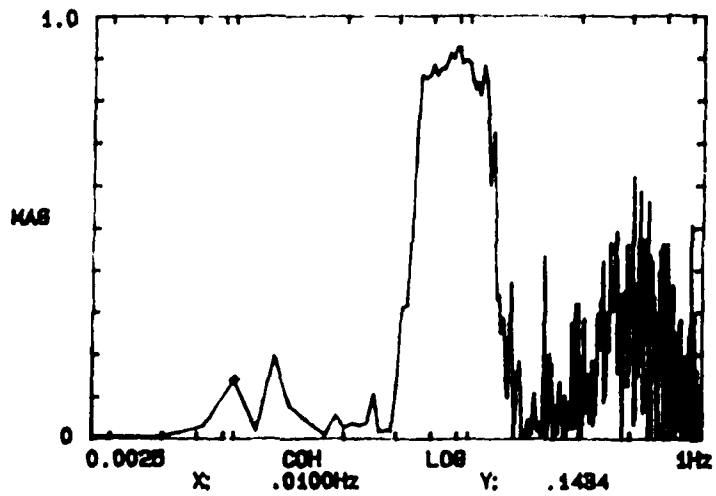

Fig. 2. Transfer function (seismometer/pressure) and coherence spectra computed from the data in Figure 1.



In deep water, however, anticipated station-keeping difficulties while attached to the mooring cable plus the prohibitive cost of 3000 meter lengths of multi-conductor cable led to the development of the new system.

In the deep water array the major changes, and they were significant, were to digitize all signals, multiplex them onto a single conductor coaxial cable and, at the surface, telemeter them to a nearby tender ship which is then able to maneuver at will. The received signals at the ship are then re-converted to their analog form, stored and analyzed as before to retain the same real-time capability as in the prior work, described above.

SYSTEM OVERVIEW

Fig. 3 is a perspective sketch of a typical installation of the deep water OBS array. During deployment, OBS#1 and #2 along with the anchors are first lowered to the bottom. Subsurface buoys are then attached to support the wet weight of the cable and minimize the load on the surface buoy.

At this time, with the surface telemetry buoy still on deck, it is possible to power both OBS packages and confirm that they are functioning properly. The surface buoy is then deployed leaving the ship free to maneuver.

The acoustic transponder at each OBS is used to measure slant range from the ship and thereby, the OBS spacing. The main anchor serves, not only to absorb the excess buoyancy of the subsurface floats, but to isolate the mooring motion from the OBS packages.

SYSTEM COMPONENTS

In this section the function and the operation of the system components are briefly described. Detailed specifications are given later

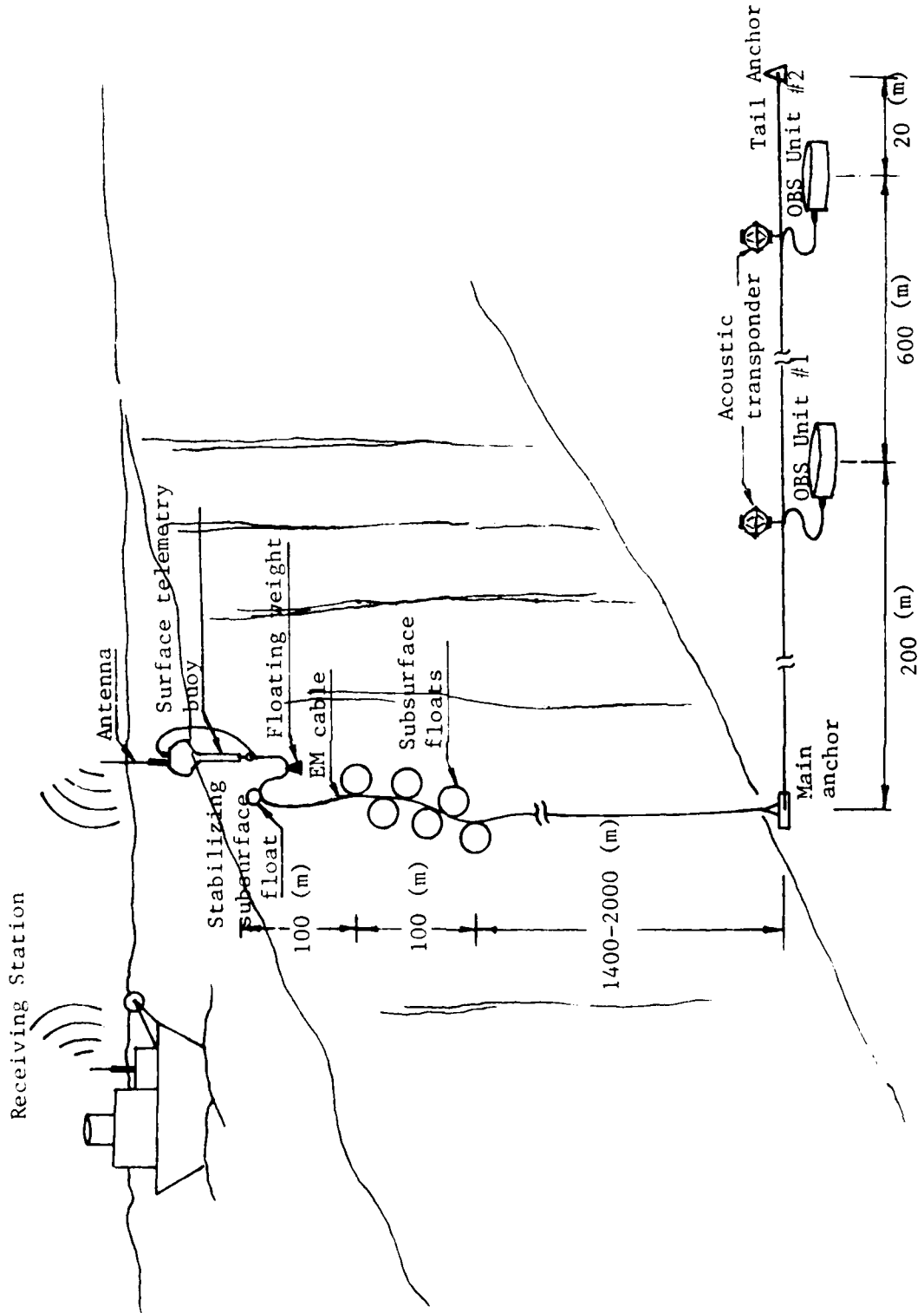

Fig. 3 Perspective view of a typical mooring system used in deep-water array.

in the Appendix.

OBS

The OBS sensors and electronics are mounted within a low-profile, circular shroud (Fig. 4) designed to maximize coupling to the ocean bottom and to minimize coupling to the ocean currents. Package weight in sea water is approximately 34 kg.

Mounted inside the shroud are three separate elements (Fig. 5): the pressure sensor which must be exposed to the ambient environment, a watertight housing containing the seismometers and inclinometers, and a watertight housing containing the signal processing electronics (i.e. digitizer, filters, amplifiers and power conditioners). All three elements are interconnected by multi-conductor underwater cables.

The seismometers (Fig. 6) used were developed by Teledyne Geotech for bore-hole work and have a high pass corner period of 100 sec. The pressure sensor (Fig. 7) selected for this system is patterned after the unit described by Cox, et al⁶ to measure differential pressure in deep ocean.

Two gain channels (Fig. 8 and 9) are provided for each of the seismometers and pressure sensor and, upon reception at the ship receiving station, the channel providing the maximum sensitivity without signal saturation is chosen by the user for recording.

All sensor signals are digitized with a 12 bit A/D converter (resolution of 1 part in 4096) having a channel scan rate of 4 per second. The resultant multiplexed, serial, digital signal then modulates a carrier frequency on the mooring modem board and is transmitted up the coax mooring wire to the surface telemetry buoy.

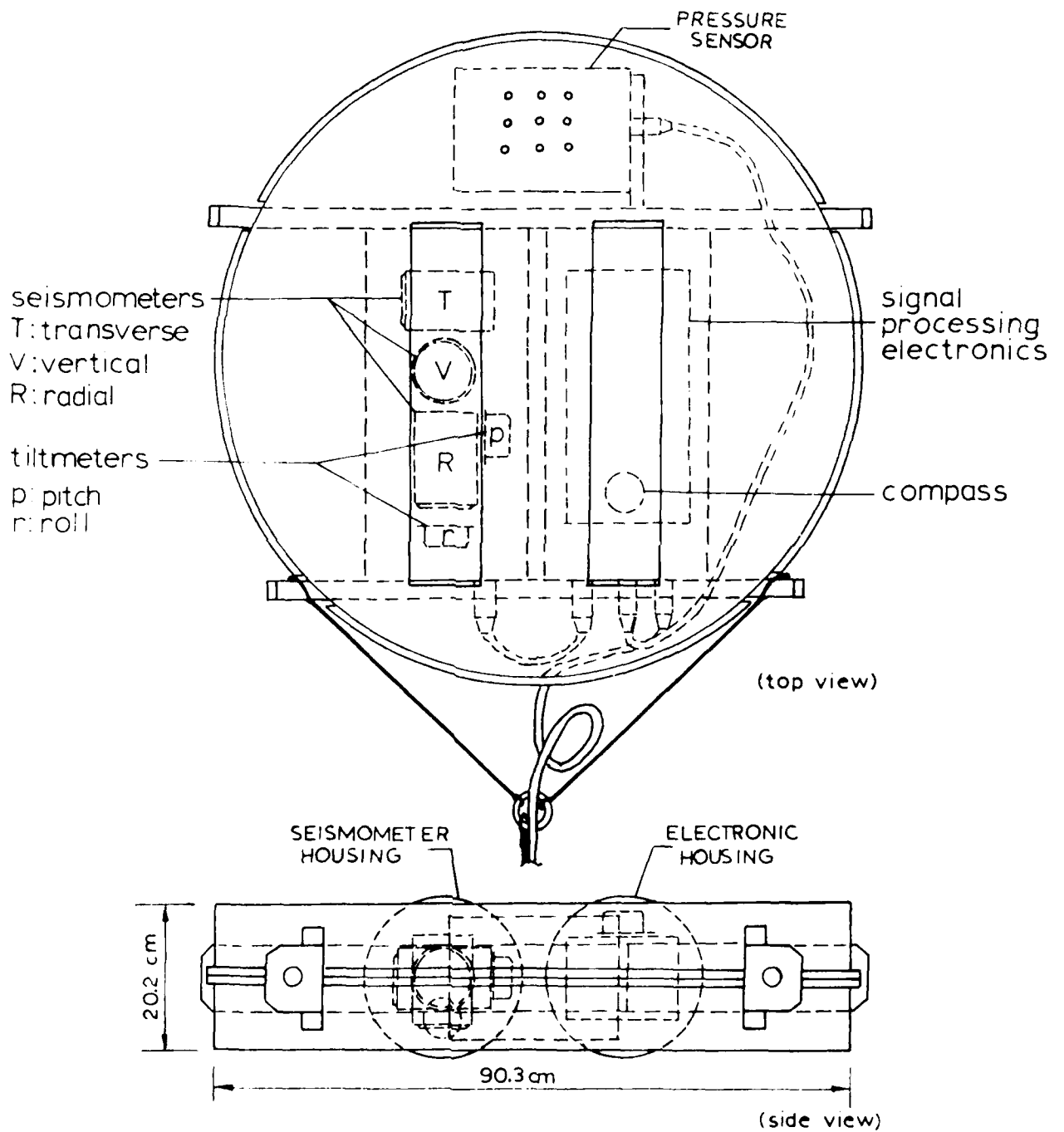

Fig. 4 Plan view of the OBS package showing the two water-tight housings and the pressure sensor contained within the low-profile shroud.

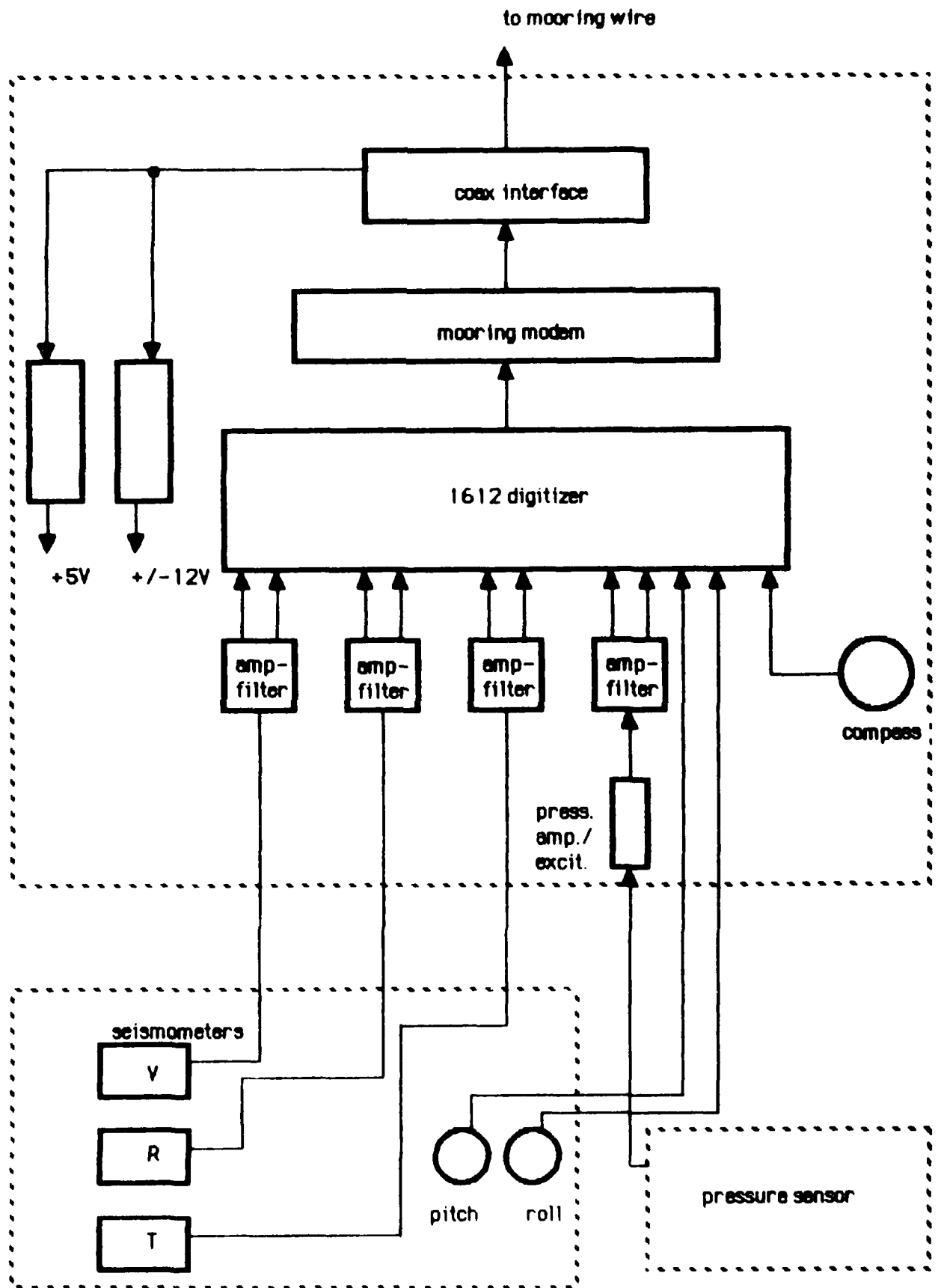

Fig. 5. Block diagram of the OBS electronic package.

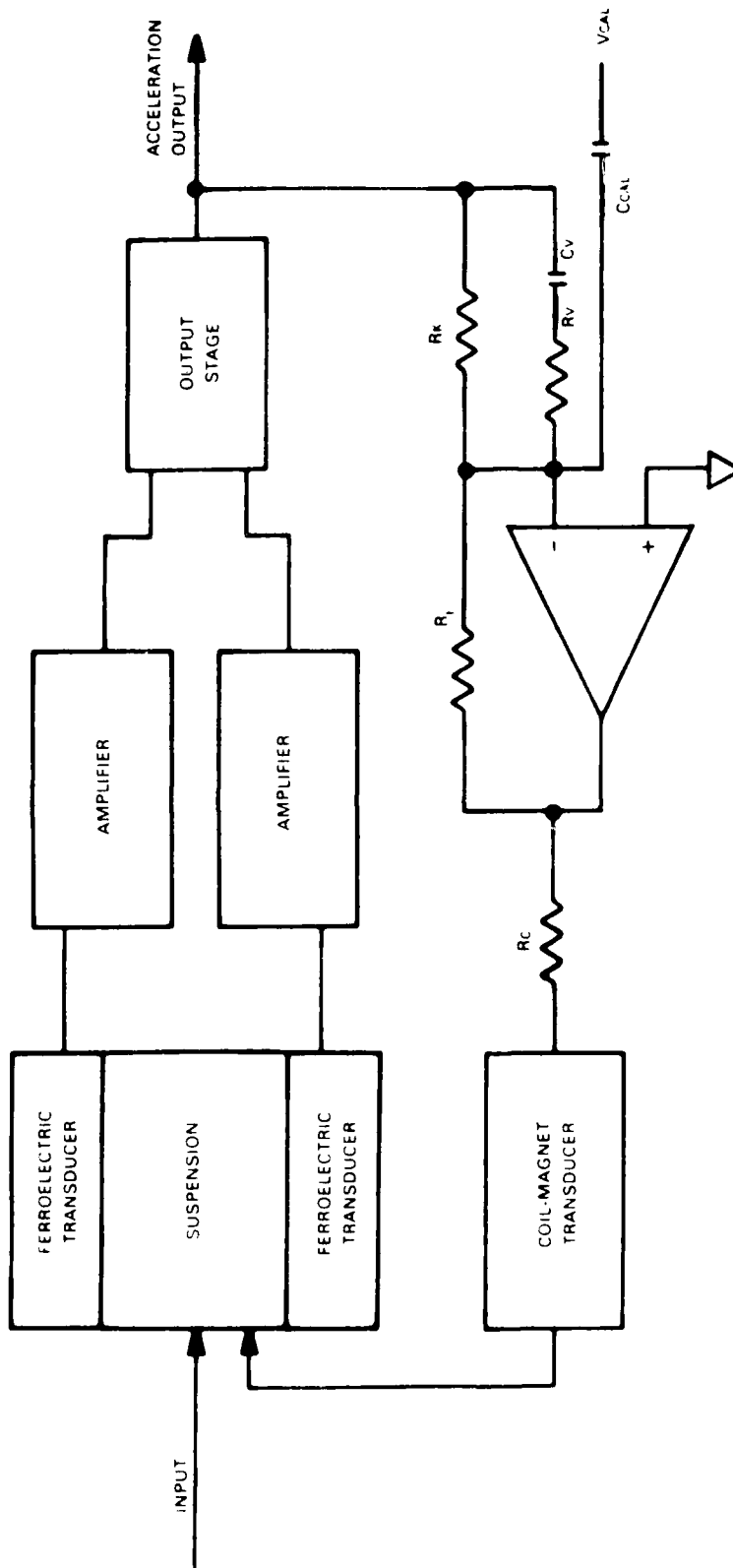

Fig. 6. BLOCK DIAGRAM - S750A SEISMOMETER (Ref. 9)

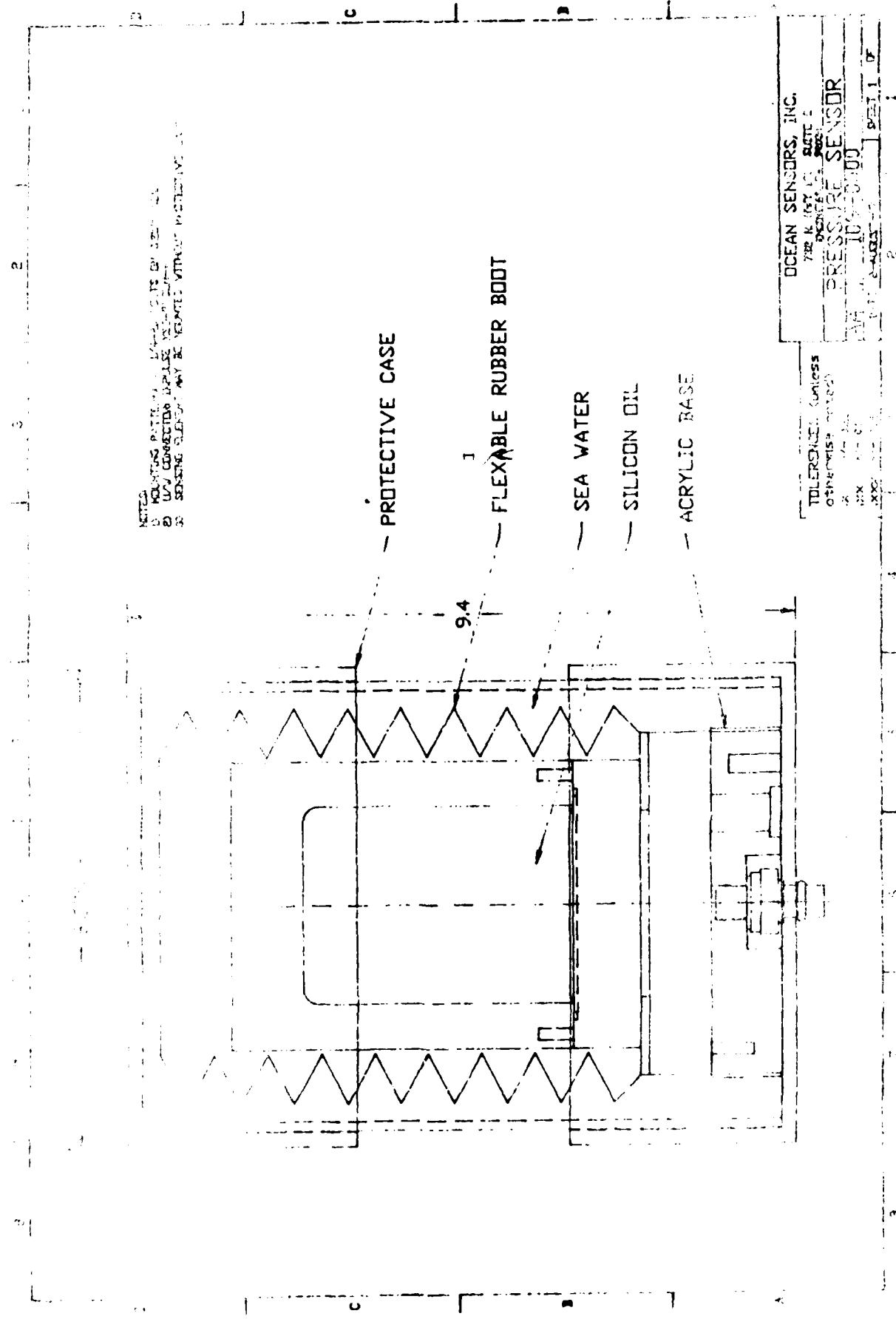
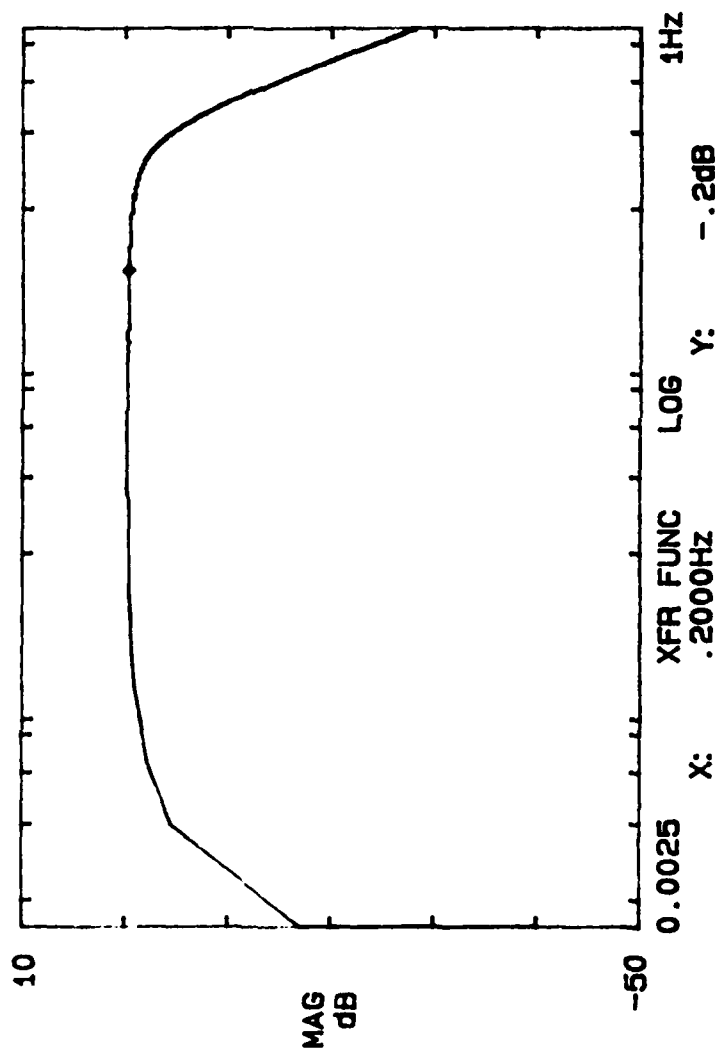

Fig 7. Differential Pressure Sensor

1Hz A: DC/ 1V B: DC/ 1V S: SUM 8192/8192 DUAL 1k



02:02

Fig. 8. Gain response of seismometer and pressure filters.

1HZ A: DC/ 1V B: DC/ 1V S.SUM 8192/8192 DUAL 1K

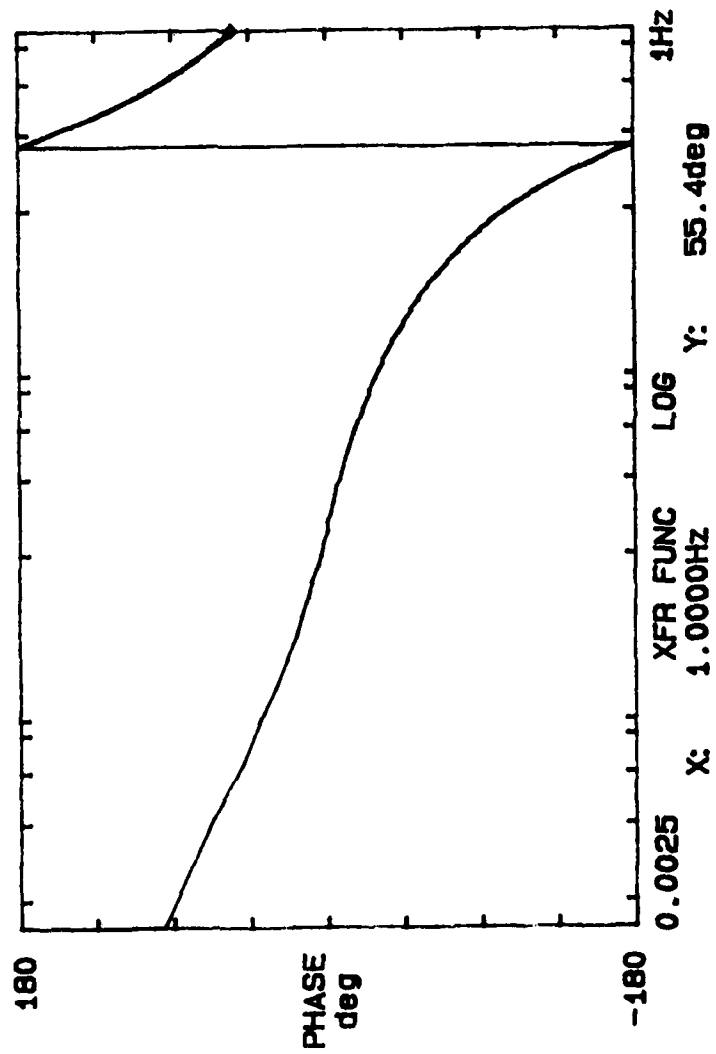

02:04

Fig. 9. Phase response of seismometer and pressure filters.

Mooring

The mooring is a single, 3,000 m section of double armored coaxial cable with 3 electrical taps (one for system expansion) along its length. The center conductor and coax shield supply power down the mooring to each OBS. Signals sent up the mooring to the telemetry buoy use the same coaxial cable and appear as modulation on a carrier frequency supplied by the OBS modem. Expansion to a three-element array has been simplified (\$65K for an additional OBS package) by including a third electrical tap during cable manufacture.

Along the length of the mooring, mechanical tie-points are provided to attach each OBS plus the primary and tail anchors. Near the top of the mooring, cable grips are used to attach six to eight subsurface floats. These floats support the weight of the mooring wire and help offset the horizontal component of the drag due to ocean currents. The size and placement of the floats plus the anchor weight was computed using the model of Skop and Mark⁷. A sample mooring calculation is given in appendix B.

At the surface a mechanical termination and a water-tight electrical connector provide attachments points for the telemetry buoy.

Telemetry Buoy

The telemetry buoy is a 3.1 m long, spar design with flotation collar (Fig. 10). A watertight housing the length of the spar contains the batteries for the OBSs and the two telemetry transmitters. Five circuit cards are (Fig. 11) also contained within the housing. One board acts as a coax interface to combine the DC battery voltage and the modem carrier frequencies. Two boards are voltage conditioners and two boards are modems to demodulate the upcoming signals from each OBS and convert

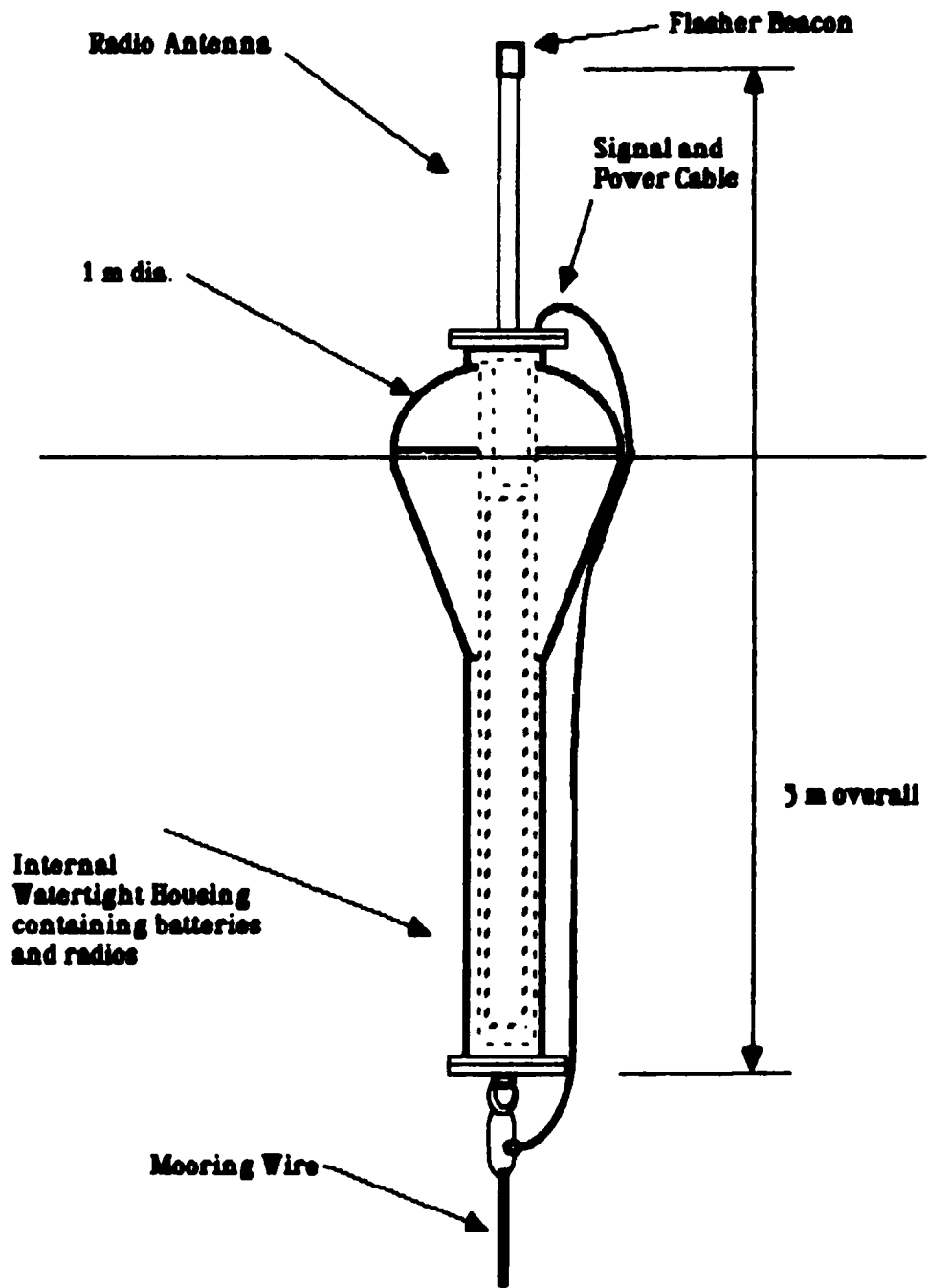

Fig. 10. Surface Telemetry Buoy.

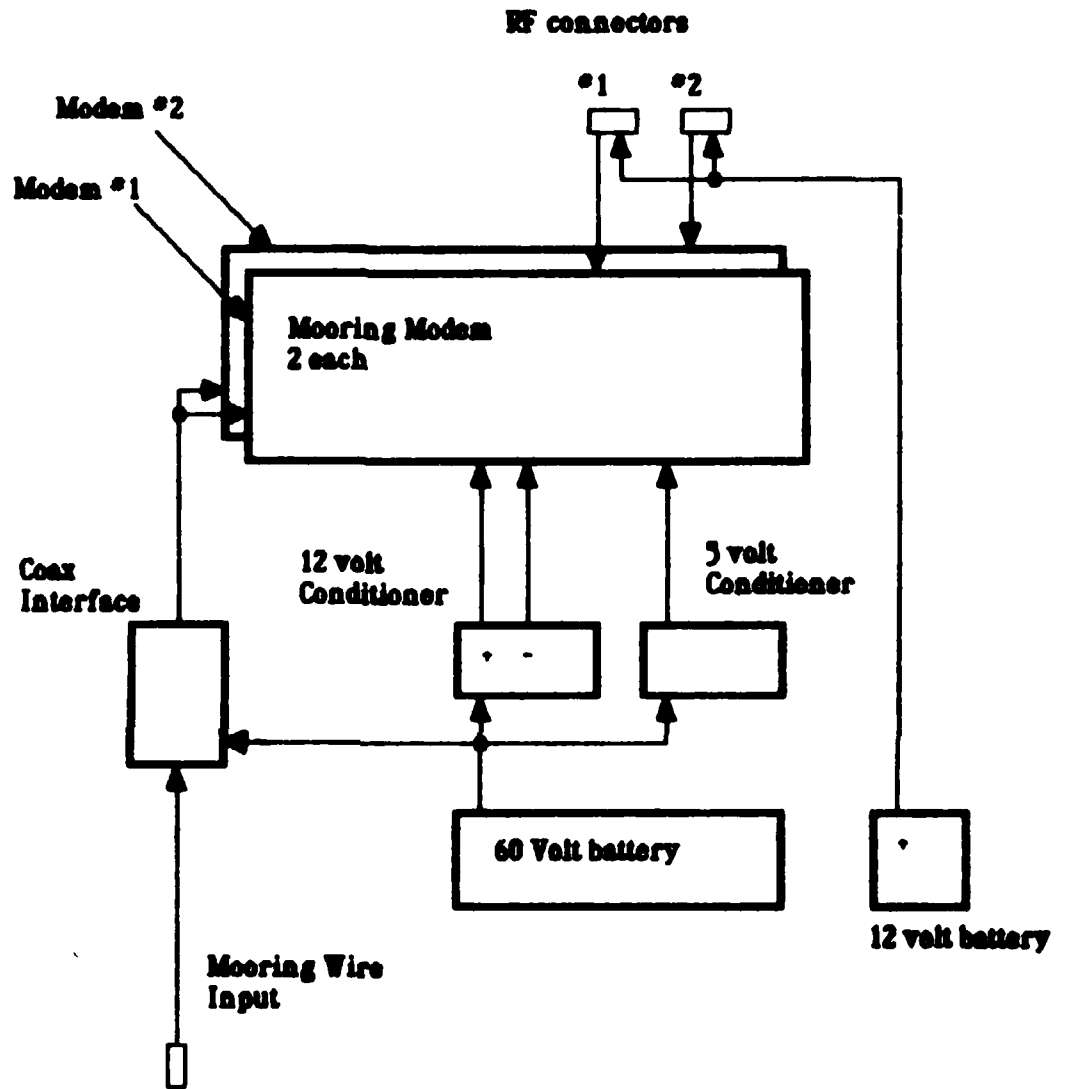

Fig. 11. Block diagram of telemetry buoy electronics.

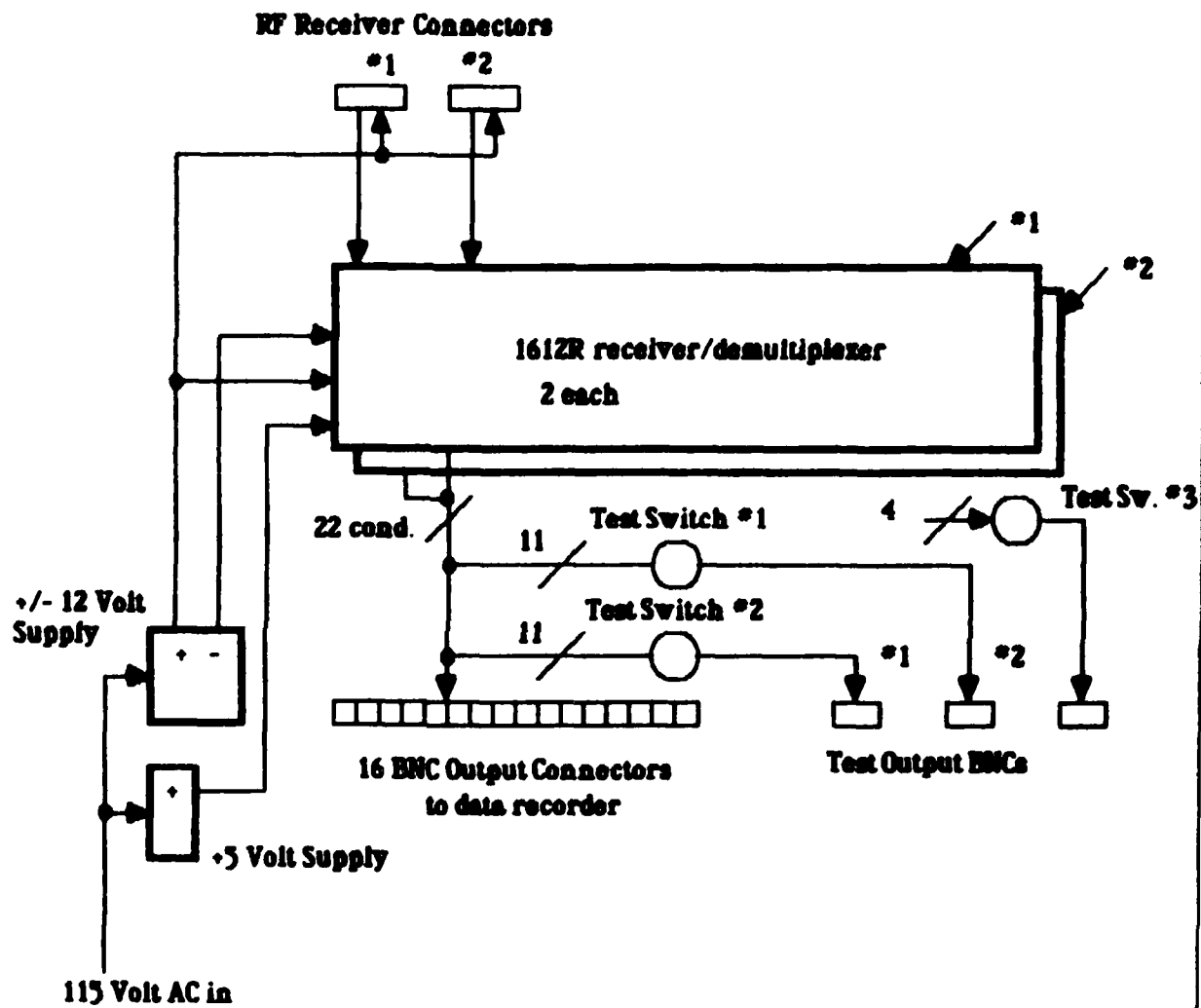

Fig. 12. Block diagram of receiving station electronics.

them to 1200 baud, RS-232 compatible voltages. One of the authors⁸ has used a similar technique at 300 baud to transmit sub-surface current measurements to shore.

The battery pack has two outputs: a 12 volt output to power the transmitters, and a 60 volt output to power the OBSs through the resistive losses of the mooring conductors. The battery capacity provides 120 hours of continuous operation before replacing or recharging. Radio range is approximately 8 km using vertical antennae.

Receiving Station

On-board the tender ship, two UHF receivers convert the incoming radio signals to a serial, digital format (RS-232) compatible with the inputs of two teledyne Geotech 1612R data receivers (Fig. 12) Each Teledyne 1612 then de-multiplexes the serial bit stream and converts the resultant digital data to analog voltages that replicate the OBS sensor voltages. These voltages are recorded on a multi-channel analog instrumentation recorder and, simultaneously, processed by a dual channel FFT analyzer. Hard copy plots are provided by an XY plotter.

SUMMARY

A deep-water OBS array with real-time telemetry has been developed and is now available. This system, composed of two discrete sensing packages and the attendant processing and transmitting electronics, provides a user with all the hardware necessary for seismic measurements in water depths to 2000 meters and real-time (via radio telemetry) recording and field analysis of the resultant data. Operating in the ULF/VLF band, the array provides rapid deployment and measurement of low-frequency, ocean-bottom ambient noise.

The appendix contains detailed engineering specifications.

REFERENCES

1. Yamamoto, T., A. Turgut, M. Badiey, D. Goodman, C.E. Abbott, 1987: High resolution bottom shear modulus profiler experiments on the New Jersey shelf from August 26 to September 4, 1987. Preliminary Research Cruise Report, University of Miami, Miami, FL., 29 pages.
2. Turgut, A., T. Yamamoto, M. Badiey, M. Trevorow, 1987: Bottom shear modulus profiler: a remote sensing instrument. To be presented at the 3rd Symposium of the ETCE, January, 1988, New Orleans, LA.
3. Trevorow, M.V., M. Badiey, A. Turgut, C.S. Conner, and T. Yamamoto, 1987: A quantitative analysis of seabed shear modulus inversions from experiments on the New Jersey Shelf in August, 1986. Technical Report RSMAS TR-87-003. University of Miami, Miami, FL, 131 pages.
4. Trevorow, M., T. Yamamoto, M. Badiey, A. Turgut and C. Conner, 1987: Experimental verification of seabed shear modulus profile inversions using surface gravity (water) wave-induced seabed motion. Submitted to the Geophys. J.R. Astr. Soc.
5. Yamamoto, T., and T. Torii, 1986: Seabed shear modulus profile inversion using surface gravity (water) wave-induced bottom motion. Geophys. J.R. Astr. Soc., 85, 413-431.
6. Cox, C., T. Deaton and S. Webb, 1984: A deep-sea differential pressure gauge. *J. Atmos. and Oceanic Tech.*, 1, No. 3, 237-246.
7. Skop, R.A. and J. Mark, 1973: A Fortran IV program for computing the static deflections of structural cable arrays. Naval Research Laboratory Report 7640, Washington, D.C. (NITS Tech. Report AD-767309).
8. Abbott, C.E., 1986: Telemetry buoy system for half-duplex communication with an S-4 current meter. Marine Data Systems International Symposium (MDS'86), April 30-May 2, New Orleans, LA.
9. Model 54100 3-component Seismometer Description and Performance Characteristics. Teledyne Geotech Manual, Garland, TX 1985.

APPENDIX A

SYSTEM SPECIFICATIONS

OBS SPECIFICATIONS

OBS Dimensions (2 per system):

Diameter: 94 cm Height: 23 cm
Weight in air: 7.26 kg Weight in water: 34 kg

Watertight Housings (2 per OBS):

Diameter: 23 cm Length: 48 cm

Sensors:

Seismometer:

Type: Teledyne Geotech Model S-750 (3 per OBS)
Sensitivity: 10^{-2} meter/second²/volt
Self-noise: 10^{-6} meter/second²/root Hz @ 100 sec
Bandpass: .01 to 100 sec @ 3dB corners

Pressure:

Type: Ocean Sensors Model 109-000
Sensitivity: 3×10^2 Pa/volt
Self-noise: 10^{-4} Pa/Hz @ 100 sec
Bandpass: 1 to 140 sec @ -3 dB corners
Diameter: 17 cm Length: 24 cm

Clinometer (2 per OBS):

Type: Sperry Model 02383-01
Sensitivity: 60 mvolts/deg Range: +/-45 deg linear
Accuracy: +/-1 percent FS Time constant: 0.3 sec

North-Seeker:

Type: Aanderaa Model 1248, clamped resistance
Sensitivity: 14 mvolts/deg Accuracy: +/-2 degrees
Time constant: 3.5 sec

Circuit Cards:

- a. Digitizer (1): 12 bit, 16 channel, 4 scans/sec.
RS-232 serial out, 5 volt bipolar input
- b. Anti-aliasing Filter/ Amp (4): dual gain output, user selectable gain
Bandpass, 2 to 250 sec @ -3 dB corners
- c. Power Conditioner (1): +/-12 volt, 5W
- d. Power Conditioner (1): +5 volt, 2W
- e. Mooring modem (1):
- f. Coax interface (1):
- g. Pressure bridge excitation/amp (1):

OBS Power Consumption: 8.5W

MOORING SPECIFICATIONS

Cable

Type: Brantner & Assoc., double armored coaxial

Length: (3020 meters, 10,000 ft)

Weight in air: 1.1 kg/m (3334 kg total)

Weight in water: .824 kg/m (2513 kg total)

Diameter: 1.93 cm

Min. Bend Diameter: 92 cm

Working load: 2268 kg

Breaking strength: 13610 kg

Conductor Resistance: 17 ohms

Shield Resistance: 10 ohms

OBS Taps: 3 @ 1800, 2400, 3000 meters

Anchors: 590 to 680 kg main, 12 kg tail

Buoys (6): .95 m diameter, steel, 300 kg

Transponders (2 each): Benthos Model XT-6000

Frequency: 10.5 KHz and 13.5 KHz

Transmit Pulse: 10msec

Detection Jitter: +/-0.1 msec

Diameter: 10"OD

Weight in air: 8.6 kg

Buoyancy in seawater: .45 kg

Handling Winch required:

Drum Dimensions:

Diameter: 92 cm Length: 96 cm Flange: 150 cm dia.

Winch HP: 25

TELEMETRY BUOY SPECIFICATIONS

Type: Spar with flotation collar

Length: 3.1 m, excluding antenna mast

Buoy Diameter:

Spar: 24 cm OD, 22 cm ID

Collar: 91 cm

Weight assembled: 250 lb

Buoyancy: 159 kg

Freeboard: 60 cm

Electronic Cards:

- a. Mooring modem (2)
- b. Coax interface (1)
- c. 12V conditioner (1)
- d. 5V conditioner (1)

RF Transmitter (2 each):

Type: MDL 2205, single channel

Modulation: Frequency, +/-3 KHz deviation

Data Input: RS-232

Frequency: 461.025, .125 MHz

Transmit Power: 0.5 watt

Data Rate: 1200 baud

Battery Pack:

Voltage: 60V(40 Amp-hr) and 12V(60 Amp-hr), 120 hour operation

Antenna: unity gain, 1/4 wave vertical mounted on 1.8 m fiberglass mast

Nominal Range: 8 km

RECEIVING STATION SPECIFICATIONS

RF Receiver (2 each):

Type: MDL 2206, single channel

Frequency: 461.025, .125 MHz

IF: triple conversion

Data Rate: 1200 baud

Sensitivity: 0.5 uV for 12 dB SINAD

Data Output: RS-232

Antenna: unity gain 1/4 wave vertical on 3 m fiberglass mast

Electronic Cabinet:

Circuit Cards:

- a. Data Receiver (1): 16 channel, 12 bit D/A, +/-5 volt analog out
- b. Power Supply (1): +/-12 @ 1A, +5 volt @ .2A

Test switches:

- a. OBS#1 signals
- b. OBS#2 signals
- c. RF status and DC voltages

Dimensions: 14"w x 12"d x 8"h Weight: 12 lb

Power Required: 115 VAC, 60 Hz, single phase, 20W

DATA RECORDER SPECIFICATIONS

Type: Teac Model SR-51 multi-channel instrumentation recorder

Channels:

- 12 - data, DC to 150 Hz @ 0.6 cm/sec, with read after write output,
0.2 to 10 volt input range
- 1 - block ID#, with playback search
- 1 - speed servo, for minimum jitter, skew and time base error
- 1 - voice memo, microphone input

Record Speed: switch selectable 0.6 to 152.4 cm/sec (0.6cm/sec - 32 hr/reel)

Record Media: 1/2" magnetic tape, digitally certified, 2300 ft reels

(DT-400-1/2-2300PR)

Accuracy:

Flutter: 0.2% @ 156 Hz

Amplitude: +/-1 dB

Distortion: < 2%

Non-linearity: < 0.4%

Drift: < 0.5%

Self-noise: < 10^{-4} volts/root Hz @ 100 sec

Dimensions: 18 1/4" w x 20 1/4" h x 10 1/2" d Weight: 62 lb

Power Required: 115 VAC, 60 Hz, single phase, 250 VA

FFT ANALYZER SPECIFICATIONS

Type: Ono Sokki Model CF-910, dual channel

Major Functions: Power, Cross, Phase, Complex and Coherent Output Spectrums,
Transfer, Coherence and Cross Correlation Functions.

Outputs: video screen, XY plotter control and GPIB (parallel digital
interface)

Dimensions: 17" w x 10" h x 20" d Weight: 62 lb

Power Required: 115 VAC, 60 Hz, single phase, 300 VA

XY PLOTTER SPECIFICATIONS

Type: Hewlett Packard ColorPro Model HP7440

Paper Size: 8 1/2" x 11", single sheet (ANSI "A" size)

Pens: maximum 8

Interface: GPIB

Dimensions: 18" w x 5" h x 12" d Weight: 12 lb (16 lb with power supply)

Power Required: 115 VAC, 60 Hz, single phase, 20 W

APPENDIX B

MOORING CALCULATIONS

NO ERRORS DETECTED
 PHYSICAL CHARACTERISTICS OF THE STRUCTURAL CABLE ARRAY

NO. OF ANCHORS IS 1
 JUNCTION NO. 1 X-COORDINATE 0.00 Y-COORDINATE 0.00 Z-COORDINATE 0.00

NO. OF JUNCTIONS IN ORIGINAL ARRAY IS 7

NO. OF CUTS MADE IN ORIGINAL ARRAY IS 0

JUNCTION NO. OF CUT AT WHICH CUT MADE

NO. OF CABLES IS 6

CABLE NO.	S=0 JUNC	S=L JUNC	LENGTH	DIAMETER	WEIGHT/LENGTH	DRAG COEFFICIENT	RIGIDITY	CONSTITUTIVE EXPONENT	NO. OF ELEMENTS
1	1	2	4592.0	0.760	-0.554	1.200	0.	0.000	50
2	2	3	54.6	0.760	-0.554	1.200	0.	0.000	4
3	3	4	54.6	0.760	-0.554	1.200	0.	0.000	4
4	4	5	54.6	0.760	-0.554	1.200	0.	0.000	4
5	5	6	54.6	0.760	-0.554	1.200	0.	0.000	4
6	6	7	54.6	0.760	-0.554	1.200	0.	0.000	4

PROPERTIES OF THE DEVICES LOCATED AT JUNCTIONS ARE AS FOLLOWS

DEVICE JUNC. NO.	DEVICE WEIGHT	DEVICE DRAG COEFFICIENT	DEVICE FRONTAL AREA
2	662.00	0.500	9.77
3	662.00	0.500	9.77
4	662.00	0.500	9.77
5	662.00	0.500	9.77
6	662.00	0.500	9.77
7	662.00	0.500	9.77

TOTAL NO. OF INDEXED DEVICES IS 6

CURRENT FIELD OPTION IS 1

Z-COORDINATE OF CURRENT	VELOCITY OF CURRENT AT Z
0.00	0.00
1640.00	0.50
4920.00	0.75

ACCURACY REQUIRED IN CALCULATIONS IS 1.00

DEVICE LOCATION OUTPUT RECORD 1 REFERS TO THIS ARRAY
 LARRAY EQUILIBRIUM WITH NO CURRENT

ARRAY ANCHORS

JUNC. NO. OF ANCHOR	CABLE AT ANCHOR	TENSION AT ANCHOR	X-COMP	Y-COMP	Z-COMP	HOR. -COMP	FORCE COMPONENTS AT ANCHOR	CABLE ANGLES WRT X-AXIS XY-PLANE
1	1	1276.8	0.0	0.0	1276.8	0.0	0.0	90.00

ARRAY CABLES

CABLE NO.	MAXIMUM TENSION	S-COORD OF	MINIMUM TENSION	S-COORD OF	MAXIMUM DISP.	S-COORD OF	LOCATION OF THIS POINT X-COORD Y-COORD Z-COORD	NO CURRENT LOC. OF THIS POINT X-COORD Y-COORD Z-COORD
1	3820.8	4592.0	1276.8	0.0	0.0	0.0	0.0 0.0 0.0	0.0 0.0 0.0
2	3189.0	54.6	3158.8	0.0	0.0	0.0	0.0 0.0 0.0	0.0 0.0 0.0
3	2557.3	54.6	2527.0	0.0	0.0	0.0	0.0 0.0 0.0	0.0 0.0 0.0
4	1925.5	54.6	1895.3	0.0	0.0	0.0	0.0 0.0 0.0	0.0 0.0 0.0
5	1293.8	54.6	1263.5	0.0	0.0	0.0	0.0 0.0 0.0	0.0 0.0 0.0
6	662.0	54.6	631.8	0.0	0.0	0.0	0.0 0.0 0.0	0.0 0.0 0.0

ARRAY JUNCTIONS

JUNC NO.	CABLE AT JUNCTION	TENSION AT JUNCTION	CABLE ANGLES WRT X-AXIS XY-PLANE	X-COORD	Y-COORD	Z-COORD	JUNCTION LOCATION X-COORD Y-COORD Z-COORD	DISPLACEMENT FROM NO CURRENT LOC. X-DISP Y-DISP Z-DISP
1	1	3820.8	-90.00	0.0	0.0	4592.0	0.0 0.0 4592.0	0.0 0.0 0.0
2	2	3158.8	90.00	0.0	0.0	4646.6	0.0 0.0 4646.6	0.0 0.0 0.0
3	3	2527.0	-90.00	0.0	0.0	4701.2	0.0 0.0 4701.2	0.0 0.0 0.0
4	4	1895.3	90.00	0.0	0.0	4755.8	0.0 0.0 4755.8	0.0 0.0 0.0
5	5	1263.5	-90.00	0.0	0.0	4810.4	0.0 0.0 4810.4	0.0 0.0 0.0
6	6	631.8	90.00	0.0	0.0	4865.0	0.0 0.0 4865.0	0.0 0.0 0.0
7	7	662.0	-90.00	0.0	0.0	4865.0	0.0 0.0 4865.0	0.0 0.0 0.0

INDEXED DEVICES ALONG ARRAY CABLES

DEVICE INDEX	CABLE NO.	S COORDINATE	TENSION AT DEVICE	X-COORD	Y-COORD	Z-COORD	DISPLACEMENT FROM NO CURRENT LOC. X-DISP Y-DISP Z-DISP
1	1	1	1276.8	0.0	0.0	1276.8	0.0 0.0 0.0

ARRAY ANCHORS

JUNC. NO. OF ANCHOR	CABLE AT ANCHOR	TENSION AT ANCHOR	X-COMP	Y-COMP	Z-COMP	HOR. -COMP	FORCE COMPONENTS AT ANCHOR	CABLE ANGLES WRT X-AXIS XY-PLANE
1	1	1300.7	339.8	0.0	1255.5	339.8	0.0 0.0 1255.5	0.0 0.0 74.86

ARRAY CABLES

CABLE NO.	MAXIMUM TENSION	S-COORD OF	MINIMUM TENSION	S-COORD OF	MAXIMUM DISP.	S-COORD OF	LOCATION OF THIS POINT	NO CURRENT LOC. OF THIS POINT
							X-COORD Y-COORD Z-COORD	X-COORD Y-COORD Z-COORD
1	3820.9	4592.0	1300.7	0.0	544.7	4592.0	543.0 0.0 4549.1	0.0 0.0 4592.0
2	3189.1	54.6	3158.9	0.0	545.8	54.6	544.1 0.0 4603.7	0.0 0.0 4646.6
3	2557.4	54.6	2527.1	0.0	547.0	54.6	545.3 0.0 4658.3	0.0 0.0 4701.2
4	1925.6	54.6	1895.4	0.0	548.1	54.6	546.4 0.0 4712.9	0.0 0.0 4755.8
5	1293.8	54.6	1263.6	0.0	549.1	54.6	547.4 0.0 4767.4	0.0 0.0 4810.4
6	662.0	54.6	631.8	0.0	550.0	54.6	548.3 0.0 4822.0	0.0 0.0 4865.0

ARRAY JUNCTIONS

JUNC. NO.	CABLE AT JUNCTION	TENSION AT JUNCTION	CABLE ANGLES WRT XY-PLANE	X-COORD	Y-COORD	Z-COORD	DISPLACEMENT FROM NO CURRENT LOC.
							X-DISP Y-DISP Z-DISP
1	3820.9	180.00	-88.86	543.0	0.0	4549.1	543.0 0.0 -42.9
2	3158.9	0.00	88.75	544.1	0.0	4603.7	544.1 0.0 -42.9
3	3189.1	180.00	-88.87	545.3	0.0	4658.3	545.3 0.0 -42.9
4	2527.1	0.00	88.74	546.4	0.0	4712.9	546.4 0.0 -42.9
5	2557.4	180.00	-88.90	547.4	0.0	4767.4	547.4 0.0 -43.0
6	1895.4	0.00	88.74	548.3	0.0	4822.0	548.3 0.0 -43.0
7	1925.6	180.00	-88.94				
8	1263.6	0.00	88.73				
9	1293.8	180.00	-89.04				
10	631.8	0.00	88.72				
11	662.0	180.00	-89.34				

INDEXED DEVICES ALONG ARRAY CABLES

DEVICE INDEX NO.	CABLE NO.	S COORDINATE	TENSION AT DEVICE	X-COORD	Y-COORD	Z-COORD	DISPLACEMENT FROM NO CURRENT LOC.
							X-DISP Y-DISP Z-DISP
1							

END

FEB.

1988

DTIC