

2

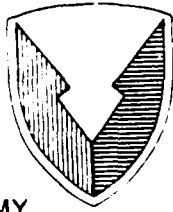

US ARMY
LABORATORY COMMAND
MATERIALS TECHNOLOGY
LABORATORY

AD

DTIC FILE ONLY

MTL TR 87-56

CRACK ARREST FRACTURE TOUGHNESS OF ARMOR STEELS

October 1987

E. J. RIPLING
Materials Research Laboratory, Inc.
One Science Road
Glenwood, IL 60425

FINAL REPORT

Contract DAAG29-81-D-0100

Approved for public release; distribution unlimited.

DTIC
SELECTED
DEC 21 1987
CS
H

Prepared for

U.S. ARMY MATERIALS TECHNOLOGY LABORATORY
Watertown, Massachusetts 02172-0001

87 12 16 024

AD-A187 711

The findings in this report are not to be construed as an official Department of the Army position, unless so designated by other authorized documents.

Mention of any trade names or manufacturers in this report shall not be construed as advertising nor as an official indorsement or approval of such products or companies by the United States Government.

DISPOSITION INSTRUCTIONS

Destroy this report when it is no longer needed
Do not return it to the originator

UNCLASSIFIED

SECURITY CLASSIFICATION OF THIS PAGE (When Data Entered)

REPORT DOCUMENTATION PAGE		READ INSTRUCTIONS BEFORE COMPLETING FORM
1. REPORT NUMBER MTL TR 87-56	2. GOVT ACCESSION NO. A187711	3. RECIPIENT'S CATALOG NUMBER
4. TITLE (and Subtitle) CRACK ARREST FRACTURE TOUGHNESS OF ARMOR STEELS		5. TYPE OF REPORT & PERIOD COVERED Final Report - 31 Jan 86 - 30 Jan 87
7. AUTHOR(s) E. J. Ripling		6. PERFORMING ORG. REPORT NUMBER MRL #7037
9. PERFORMING ORGANIZATION NAME AND ADDRESS Materials Research Laboratory, Inc. One Science Road Glenwood, IL 60425		8. CONTRACT OR GRANT NUMBER(s) DAAG29-81-D-0100
11. CONTROLLING OFFICE NAME AND ADDRESS U.S. Army Materials Technology Laboratory Watertown, MA 02172-0001 ATTN: SLCMT-ISC		10. PROGRAM ELEMENT, PROJECT, TASK AREA & WORK UNIT NUMBERS D/A Project 1L161102AH84 AMCMS Code: 61205.H840011
14. MONITORING AGENCY NAME & ADDRESS (if different from Controlling Office)		12. REPORT DATE October 1987
		13. NUMBER OF PAGES 58
		15. SECURITY CLASS. (of this report) Unclassified
		15a. DECLASSIFICATION/DOWNGRADING SCHEDULE
16. DISTRIBUTION STATEMENT (of this Report) Approved for public release; distribution unlimited.		
17. DISTRIBUTION STATEMENT (of the abstract entered in Block 20, if different from Report)		
18. SUPPLEMENTARY NOTES Administered by Battelle Columbus Laboratories and U.S. Army Research Office.		
19. KEY WORDS (Continue on reverse side if necessary and identify by block number) High strength steels, Fracture toughness, Crack propagations, Armor plate, Mechanical properties, Ballistic testing, Transition temperatures, Dynamic properties,		
20. ABSTRACT (Continue on reverse side if necessary and identify by block number) (SEE REVERSE SIDE)		

DD FORM 1473
1 JAN 73

EDITION OF 1 NOV 65 IS OBSOLETE

UNCLASSIFIED

SECURITY CLASSIFICATION OF THIS PAGE (When Data Entered)



1.0 INTRODUCTION

The reactions that occur when a projectile strikes its target are extremely complex. Nevertheless, there are some general, and relatively simple statements that can be made about the mechanism of penetration. First, penetration can occur by target deformation. Minimizing this involves increasing the target hardness. There is a limit to how much hardness can be increased, however, since increasing hardness increases the tendency for the target to fail by shattering or cracking. Charpy V-notch impact tests have been used for many years for evaluating target break-up, at least for steels. A better method for evaluating break-up, or shattering and cracking may be by the use of the crack arrest fracture toughness, K_a . Use of this property would not be restricted to steels, but could be used for other armor material as well. In addition, K_a may be an important material parameter for computer modeling projectile-target interactions.

K_a is only relevant to the last stages of a projectile-target interaction. At this stage of the event, the cracks are decelerating toward zero velocity so that the statically calculated K_a is reasonable, and it may be the resistance to cracking over this time interval that controls the area of plate damage.

This use of K_a to define plate damage area suggests that projectile-plate interaction can be treated as a crack run-arrest event. Hence the complete reaction of the plate to the projectile impact can be discussed in terms of the effect of driving force, K , on crack velocity, \dot{a} . All of the materials for which measurements of this type have been made to date; and these include metals [1], adhesives [2] and, plastics [3], are represented by an inverted "L" shaped curve of the type shown in Fig. 1.



If it is assumed that this target plate is initially unflawed at the location of impact, the projectile would first have to initiate a crack. The crack at this time would be small so that K would be small, and hence deformation might occur prior to cracking. After some initial crack formed, however, its further extension could be described by the techniques of fracture mechanics, and the stress intensity factor at which rapid cracking would initiate is shown schematically as K_0 in Fig. 1b. K would increase rapidly as the crack expanded so that during the early part of the event, the $K-\dot{a}$ relationship is shown by the right hand end of the chart, where crack branching, i.e. shattering, occurs. As the initial impact energy is dissipated, the driving force, K , decreased so that \dot{a} would also decrease, as shown by the curve, and arrest would occur at K_a .

A large number of measurements have been made on crack velocity during run-arrest segments of crack extension. Typically, higher crack velocities are obtained on intermediate strength steels than on high strength steels [4]. The lower velocities found in the higher strength materials are consistent with their smoother fracture surfaces, and suggest that the crack initiates at a K value close to the vertical branch of the curve shown in Fig. 1b. This is the behavior expected in high strength armor steels where the K -value for branch cracking, K_b , may be not much higher than K_a .

For both high and intermediate strength steels, most of the cracking occurred at the higher velocity shortly after initiation. In spite of the fact that less crack extension occurs at the lower velocity, most of the cracking time is consumed by slower cracking. It is because of the long time required for the slower cracking that a statically calculated value of crack arrest is applicable.



2.0 EARLIER CRACK ARREST FRACTURE TOUGHNESS DATA ON HIGH STRENGTH STEEL

Plane strain crack arrest fracture toughness, K_{Ia} , had been measured on AISI 4340, 4140 and 1340 steels heat treated to various strength levels, and tested over a range of temperatures on earlier projects, [5] and [6]. It is helpful to review these data before discussing that collected on the present project. K_{Ia} is plotted as a function of test temperature for the three steels in Figs. 2, 3 and 4 for yield strength levels of 965, 1100 and 1240 MPa, respectively. Although the steels were tested in different thicknesses, in all cases the specimens were through-hardened and they cracked under conditions of plane strain.

The most conspicuous feature of these data is that they generally show a pronounced transition temperature. Further, at any combination of strength level and test temperature, the AISI 4340 steel was tougher than 4140, which in turn was tougher than 1340. These toughness comparisons as a function of yield strength at a high, intermediate and low test temperature are shown more clearly in Figures 5, 6, and 7. The sensitivity of K_{Ia} to slack quenching was also investigated in one of the earlier studies. The AISI 4140 steel through-hardened in thicknesses of 13 and 19 mm but not in a thickness of 25 mm. Tests conducted on this thicker plate are compared with the data shown in Figure 3, for the 13 mm thick plate in Figure 8. Obviously, crack arrest fracture toughness is sensitive to micro-structure as well as to steel strength level and composition.



3.0 TEST RESULTS OBTAINED ON THE PRESENT STUDY

3.1 Test Materials

Test materials were supplied by AMTL to MRL as blanks roughly 155 x 155 x 13 mm thick. Thirty-two blanks were supplied: one-half identified as VAR 4340 and the other half as "Rare Earth Modified" (REM) 4130. The VAR 1340 steel was in the annealed condition, and the REM 4130 steel was in the quenched and tempered condition (Rc 52). The rolling direction was indicated on each plate with an arrow.

The AISI 4340 steel blanks were heat treated at MRL prior to machining because there was some concern that the pieces might warp or crack if the specimens were machined before heat treated. The heat treat recommended by Materials Technology Laboratory was as follows:

- A. Austenitized at 845°C for one hour, water quench.
- B. Temper at 200°C for two hours, air cool.

The REM 4130 plates were supplied as heat treated, and the heat treatment consisted of the following:

- A. Normalized at 1,040°C for one hour, air cool.
- B. Austenitized at 900°C for 15 minutes, water quench.
- C. Temper at 205°C for 30 minutes, air cool.



3.2 Test Procedure

A detailed description of the test procedure used on high strength metals is given in Appendix 2. The type of test specimen used for measuring crack arrest fracture toughness in this project is shown in Figure 9. Most tests were made with side grooved specimens, but a few had smooth sides.

The side-groove assured plane strain cracking across the full specimen thickness; the un-grooved specimen allowing the specimen surfaces that crack in plane stress, rather than plane strain, to contribute to crack resistance. For the grooved specimens, the crack fronts were generally straight, while for the un-grooved ones it was generally tunnelled, leaving an uncracked ligament at each of the specimens surfaces, Figure 10. This ligament becomes a shear lip if the crack extends far enough. The side-groove specimens are probably a better model of the type of cracking that occurs in armor plate.

3.3 Data

The test results are tabulated in Tables 1 and 2, and are plotted in Figs. 11 and 12.

3.3.1 Side-Grooved Specimen Data

The crack arrest toughness of REM 4130 steel is shown in Fig. 11, and of the VAR 4340 in Fig. 12. The scatter in both these charts is greater than that found in earlier tests on similar steels. In spite of the scatter, the curve representing the AISI 4130 data is shown to have a transition temperature mainly because this is the behavior found in the earlier studies. If the steels do, indeed, exhibit a transition temperature, the data collected on the 4340 suggest that the transition temperature would be above 38C.



The most conspicuous feature of the data, however, is that the REM 4130 is tougher than the VAR 4340 at all temperatures.

3.3.2 Un-side Grooved Specimens

Very little un-side grooved data were collected, although enough were obtained to note that the depth of the uncracked surface ligament, and subsequent shear lip, is dependent on test temperature. At the lowest test temperature the surface ligament thickness is so small that it contributes almost nothing to crack resistance, Figure 10a. Indeed, as a result of scatter, the ungrooved specimen toughness was lower than the grooved specimen at -74°C for the REM 4130 steel. At 38°C on the other hand, the surface ligament for the ungrooved specimen is larger, Figure 10b, and hence the toughnesses of REM 4130 and VAR 4340 is $1\text{-}1/2$ and $1\text{-}3/4$ times the grooved toughnesses, respectively.

4.0 CONCLUSIONS

The crack arrest fracture toughness, K_{Ia} , of the two steels were shown to be different, the 4140 being tougher than 4340. The significance of this can only be ascertained by comparing these results with firing data.



REFERENCES

1. Eftis, A. and Krafft, J. M., Jour. Basic Eng., Trans., Series D, ASME, Vol 87, 1965.
2. Mostovoy, S. Crosley, P.B. and Ripling, E. J., "Note on the Dependence of Crack Velocity on Driving Force for an Epoxy Adhesive," ASTM, STP 601, 1976.
3. Green, A. K. and Pratt, P. L., Engineering Fracture Mechanics, Vol. 6, No. 1, 1974.
4. Crosley, P. B. and Ripling, E. J., "Characteristics of a Run-Arrest Segment of Crack Extension," ASTM, STP 627, 1977.
5. Ripling, E. J., Mulherin, J. H., and Crosley, P.B., "Crack Arrest Toughness of Two High Strength Steels (AISI 4140 and AISI 4340)," Met. Trans. A, Volume 13A, April, 1982, pp. 657-664.
6. Ripling, E. J., Mulherin, J. H. and Crosley, P. B., "Comparison of the Plane Strain Crack Arrest Fracture Toughness of 4340, 4140, and 1340 Steel," Met. Trans. A., Volume 14A, July, 1983, pp. 1459-1465.



TABLE 1

K_{Ia} vs. Test Temperature (Side-Grooved Specimens)

Spec. No.	Test Temp. Deg. C	K_{Ia} MPa-m	Spec. No.	Test Temp. Deg. C	K_{Ia} MPa-m
REM 4130					
1-6	38	91	1-7	-18	109
1-5	38	110	1-4	-40	53
1-1	22	88	1-8	-40	81
1-9	22	101	1-13	-74	75
1-2	0	94	1-11	-74	89
1-16	0	112	1-14	-74	*
1-3	-18	95			
VAR 4340					
3-2	38	62.7	3-1	-18	46.9
3-6	38	62.9	3-10	-40	*
3-5	22	56.6	3-11	-40	53.2
3-12	22	55.6	3-3	-40	*
3-14	0	35.1	3-16	-74	40.4
3-4	0	57.3	3-15	-74	43.6

*Crack ran too far.



TABLE 2

K_{Ia} vs. Test Temperature (Un-grooved Specimens)

Spec. No.	Test Temp Deg. C	K_{Ia} MPa \sqrt{m}	Spec. No.	Test Temp. Deg. C	K_{Ia} MPa \sqrt{m}
REM 4130					
1-15	38	147	1-12	-74	81
1-10	-74	58			
VAR 4340					
3-8	38	122	3-13	-40	91
3-9	0	81	3-7	-74	55

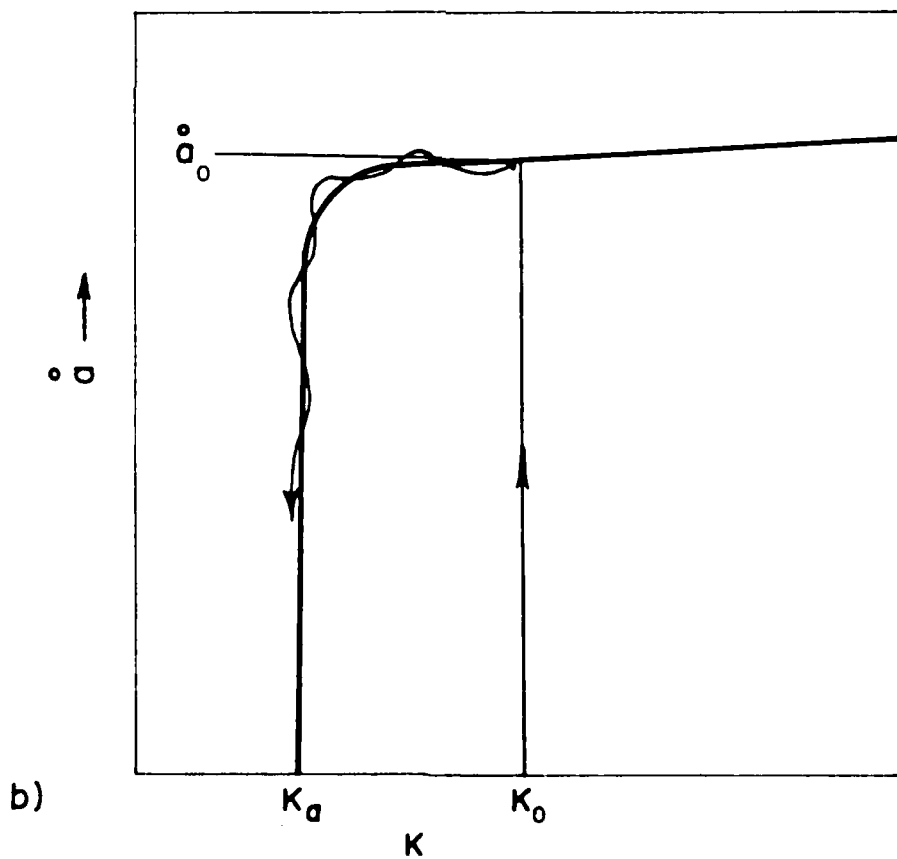
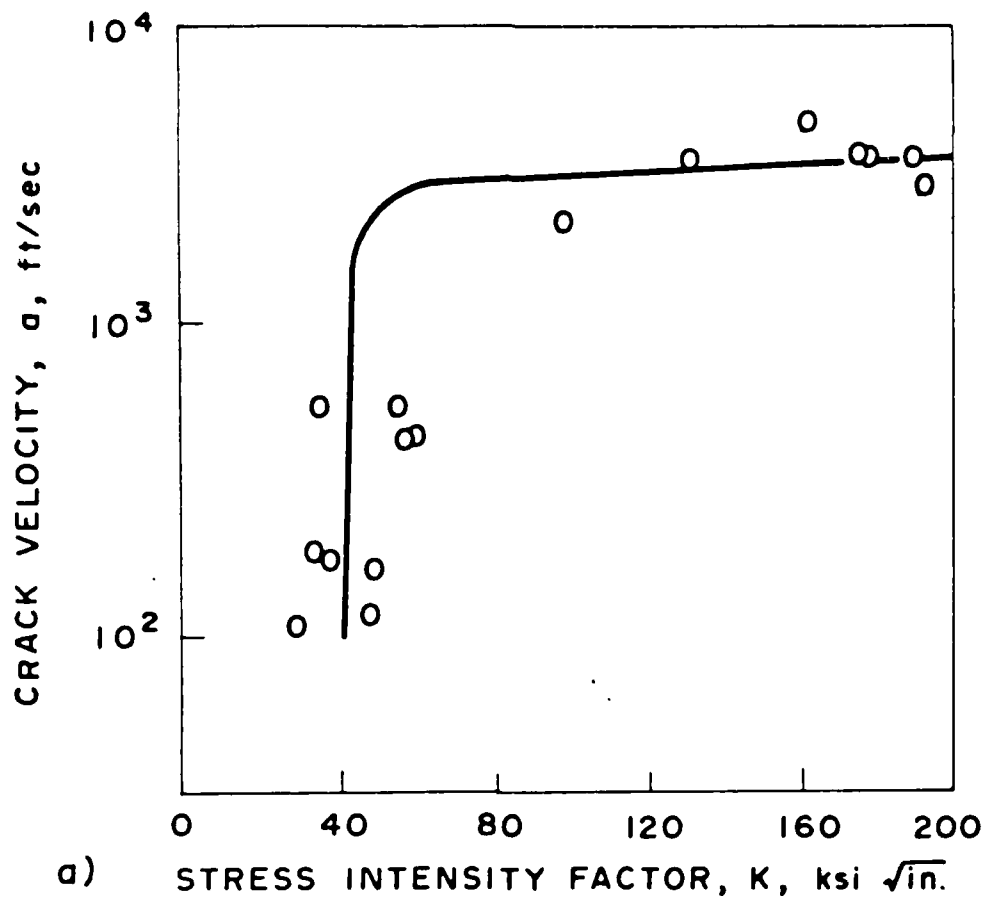

Fig. 1 (a) Dependence of crack velocity on stress intensity factor for AISI 1020 steel at 12°F (NDT = 20°F) (4).
 (b) Schematic drawing of a run-arrest segment of crack extension.

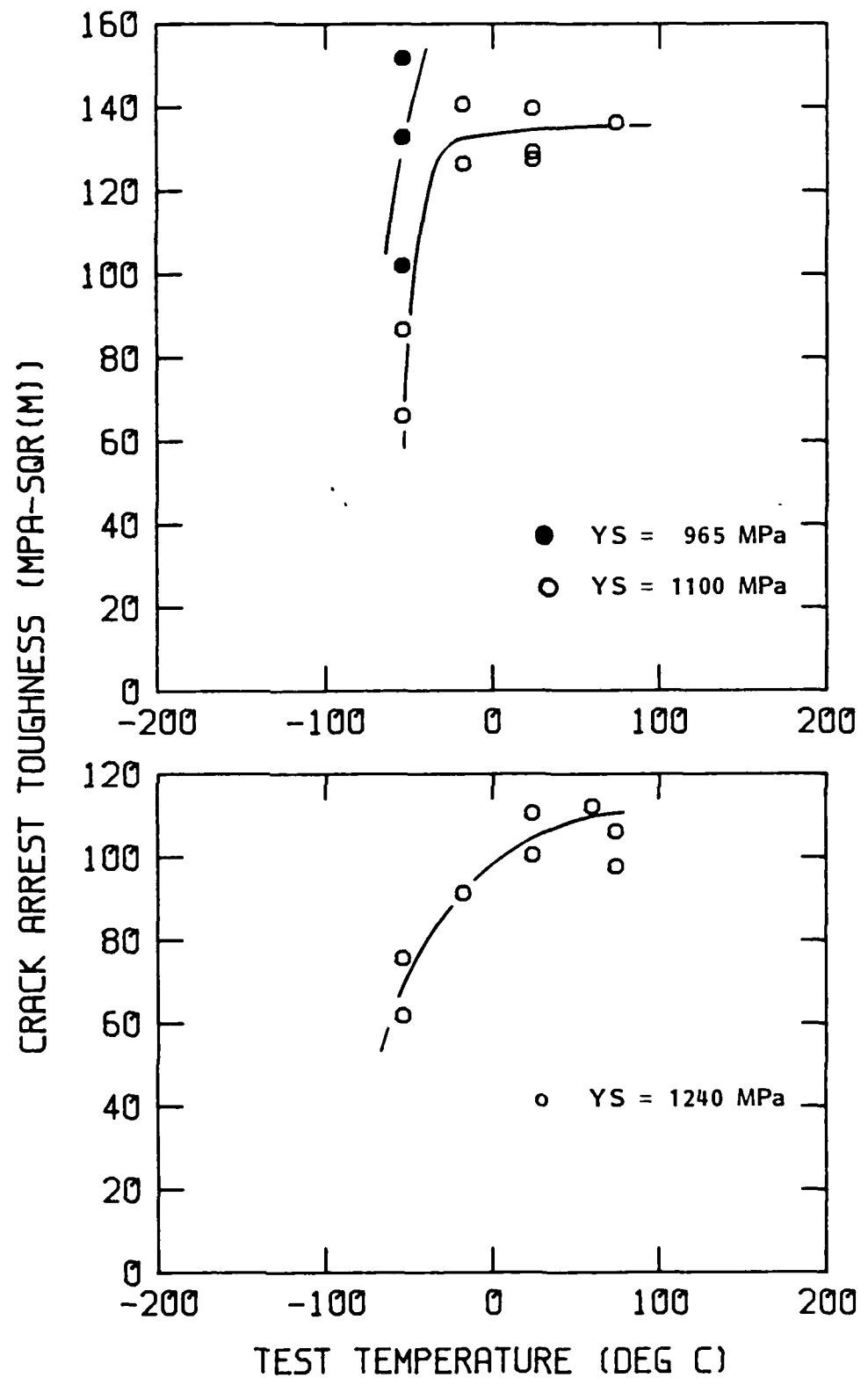

Fig. 2 Crack arrest fracture toughness of 4340 steel as a function of test temperature (25 mm thick plate) [5].

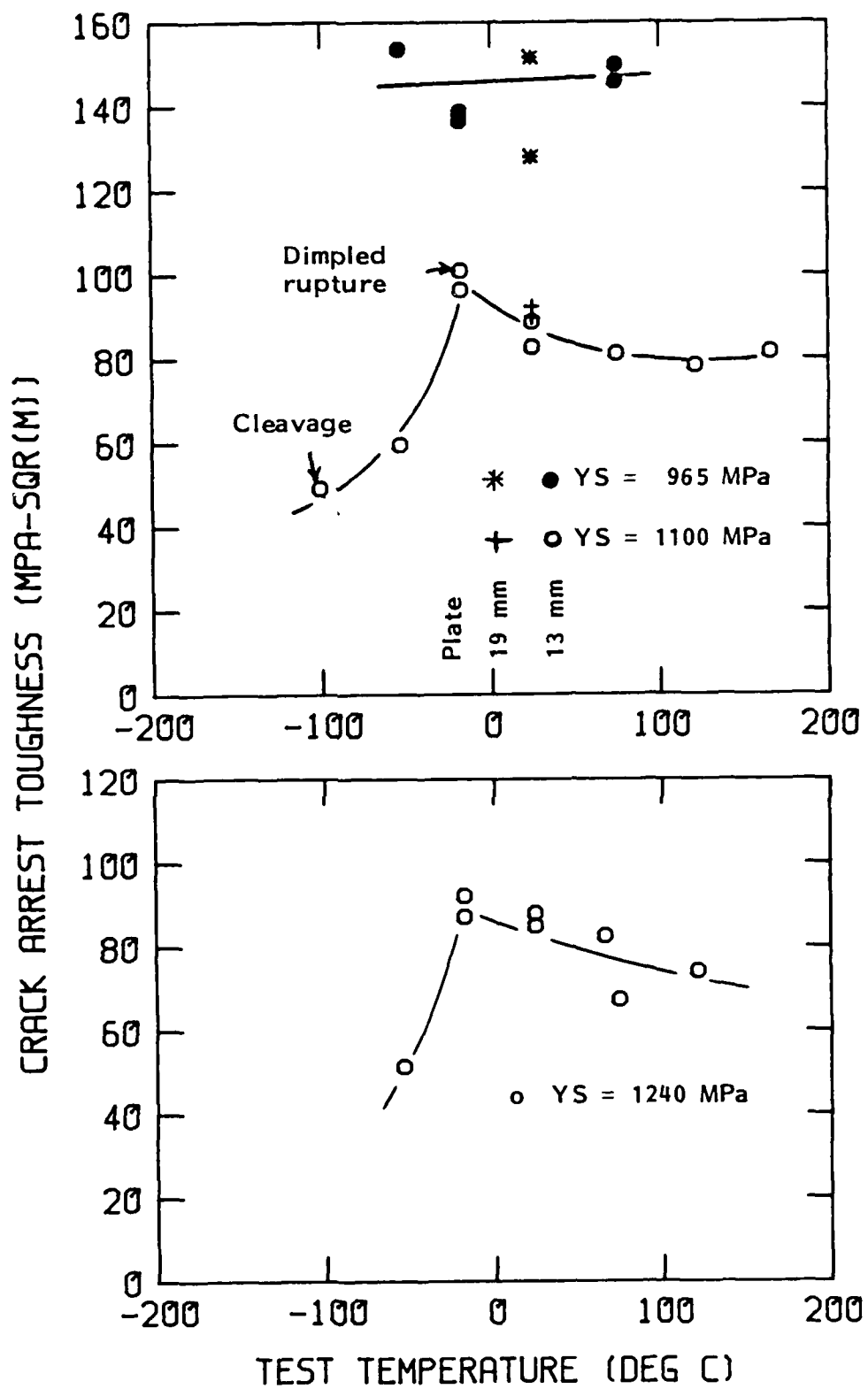

Fig. 3 Crack arrest fracture toughness of 4140 steel as a function of test temperature (13 and 19 mm thick plate) [4].

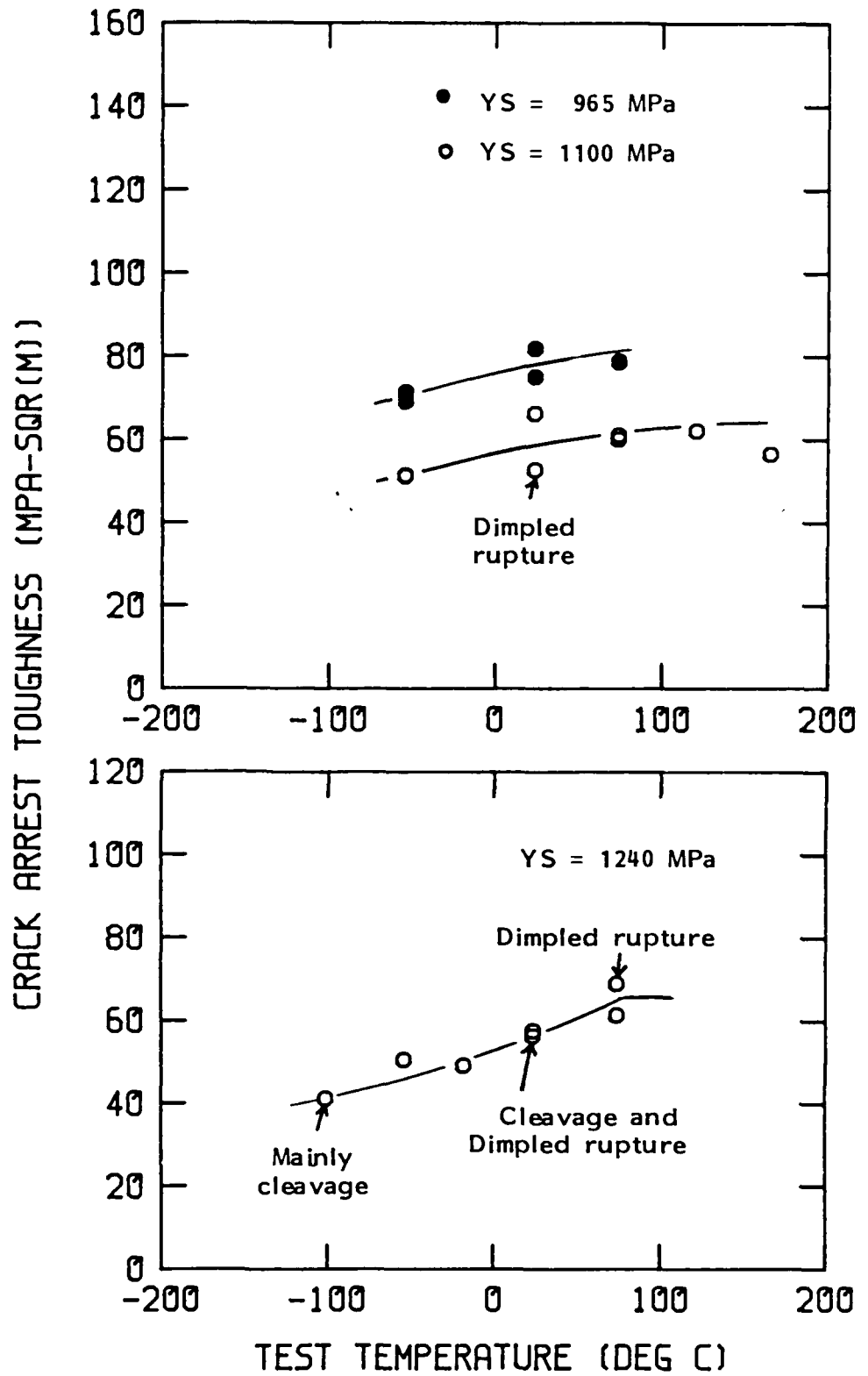

Fig. 4 Crack arrest fracture toughness of 1340 steel as a function of test temperature (13 mm thick plate) [4].

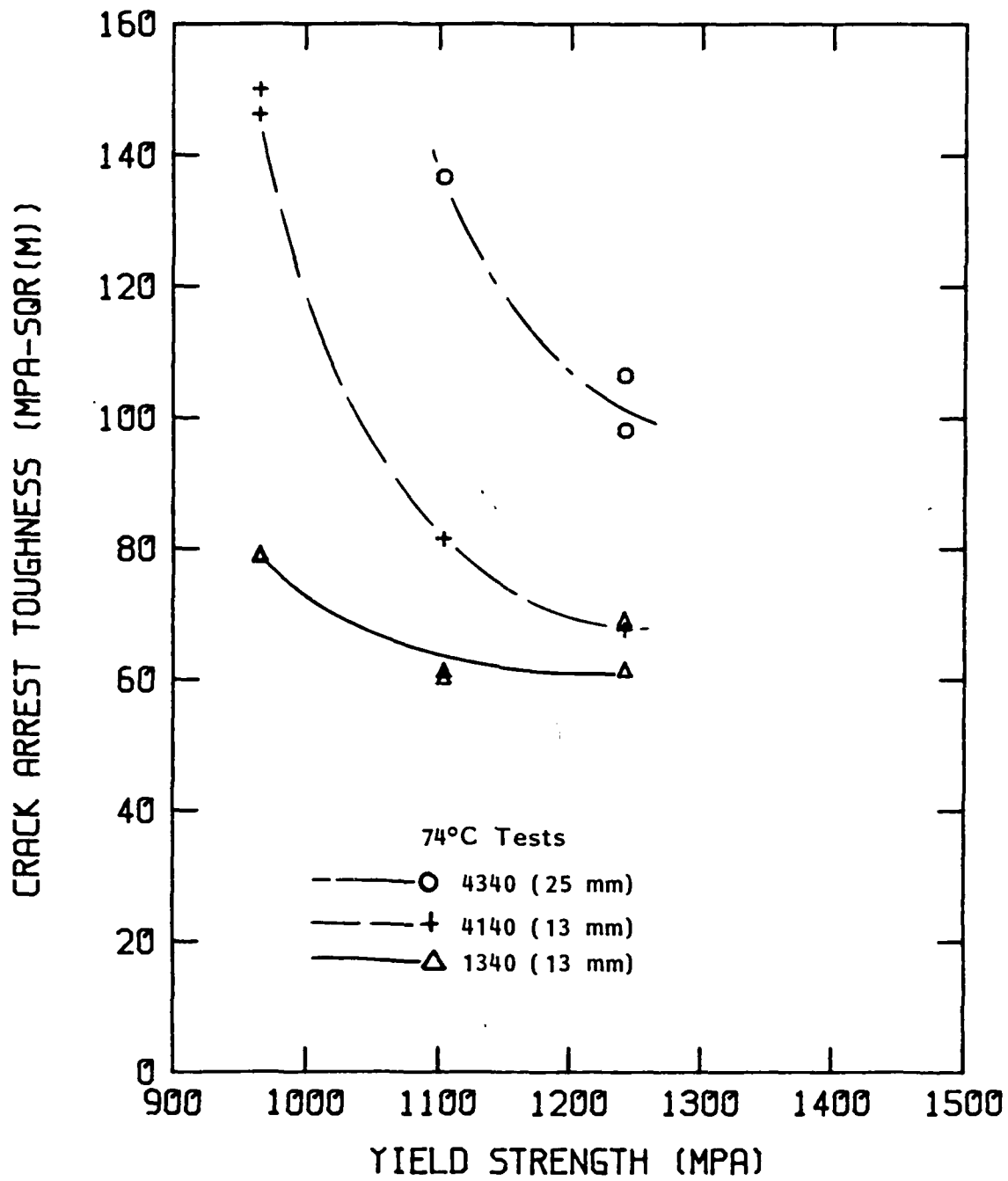

Fig. 5 Comparison of the crack arrest toughness of the three steels when tested at +74°C [4].

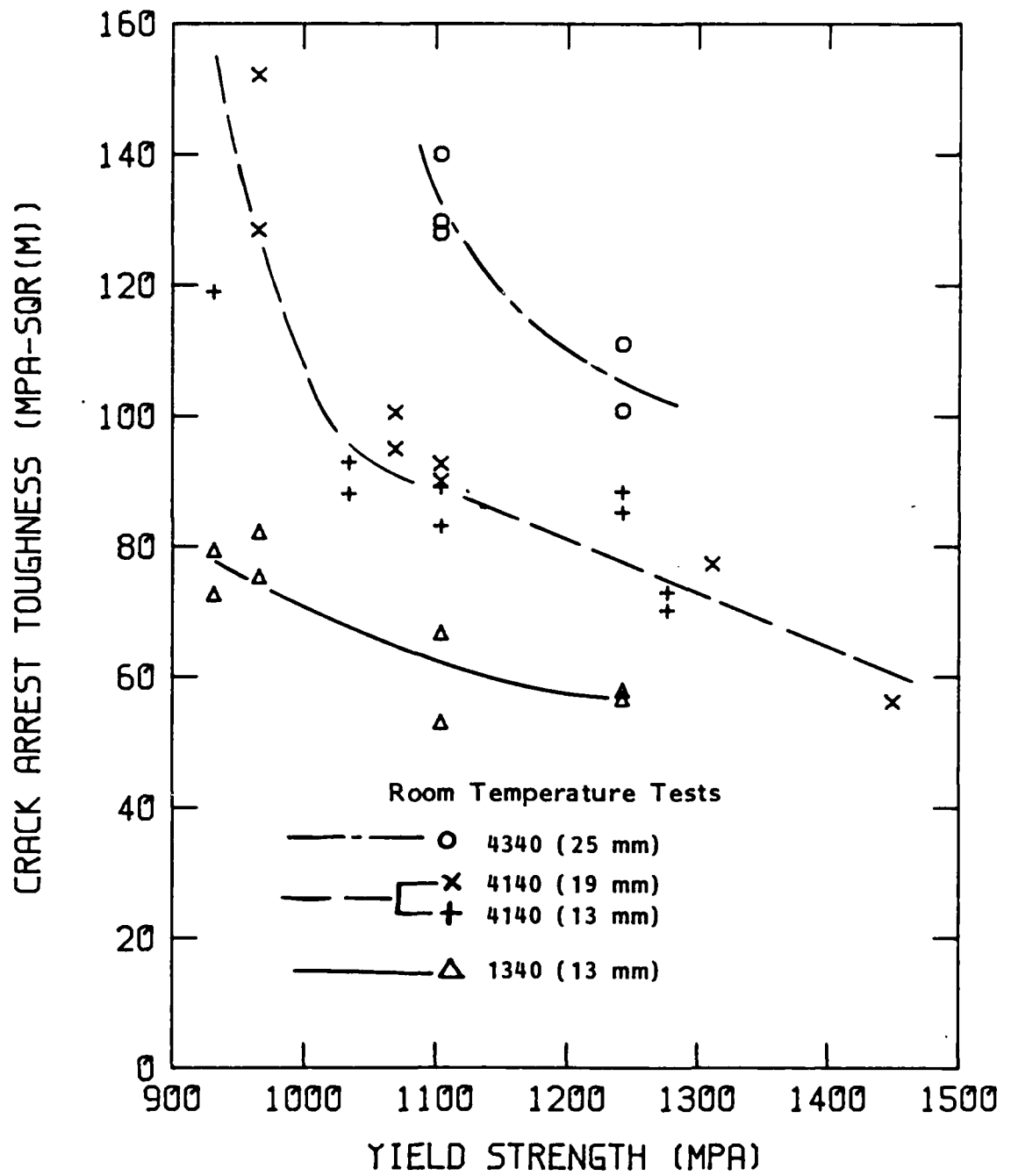

Fig. 6 Comparison of the crack arrest toughness of the three steels when tested at room temperature [4].

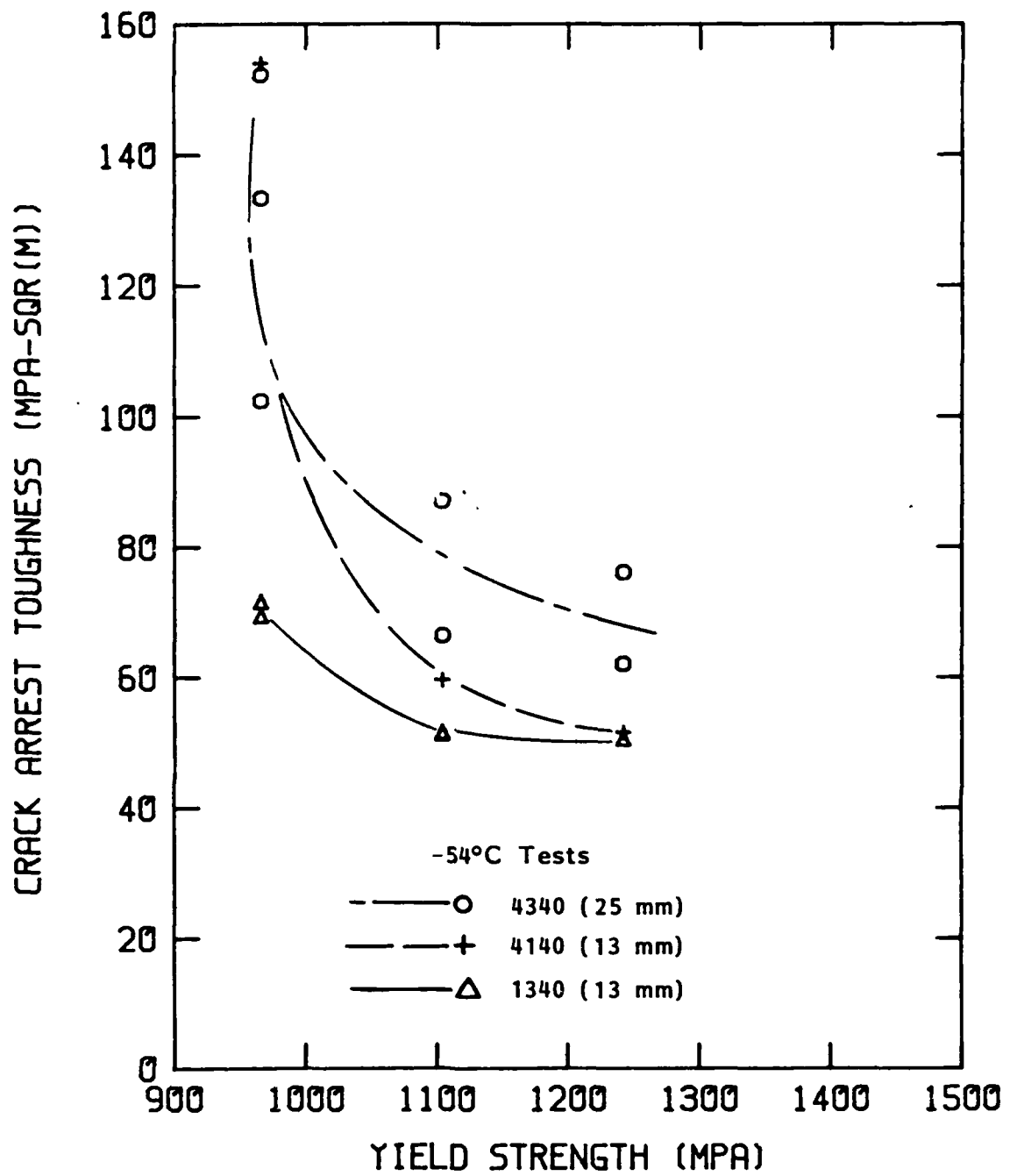

Fig. 7 Comparison of the crack arrest toughness of the three steels when tested at -54°C [4].

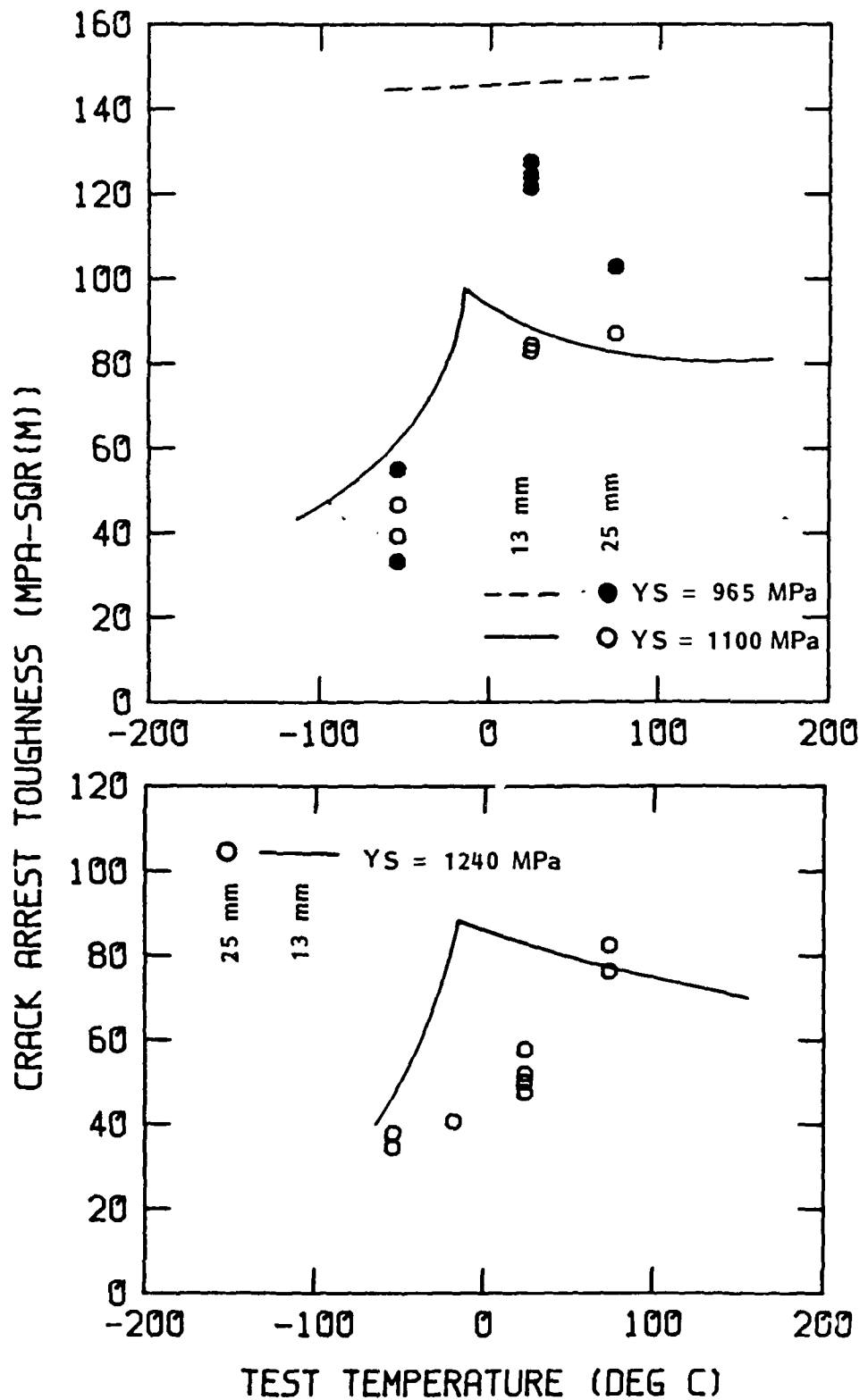
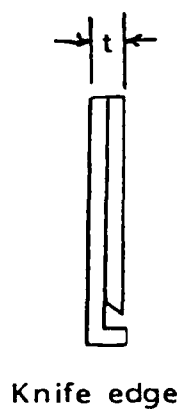
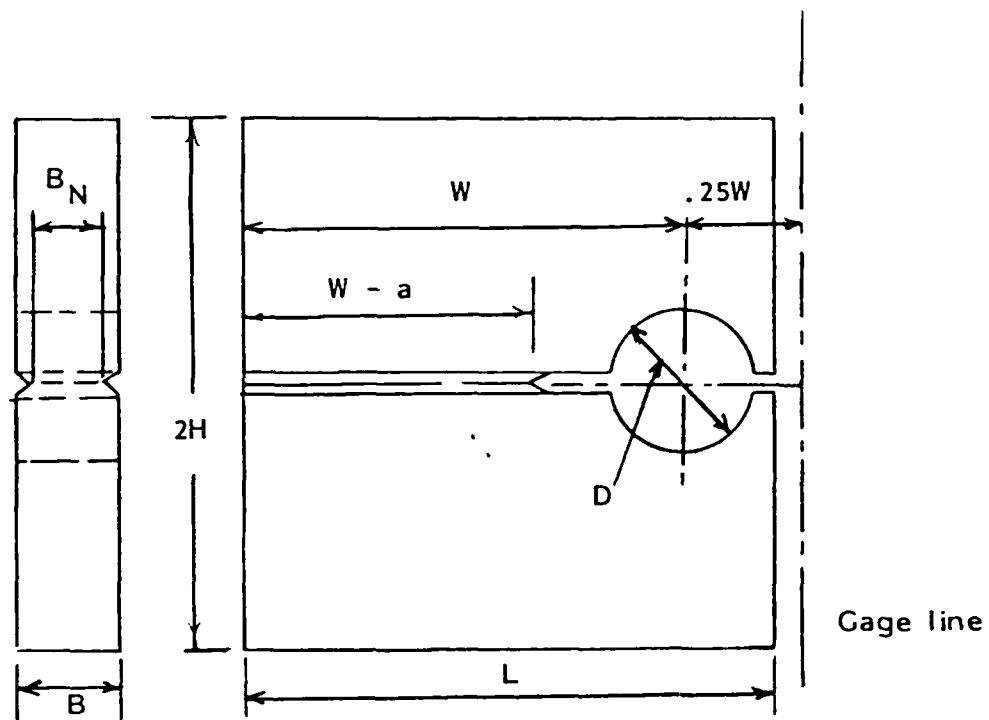

Fig. 8 Comparison of K_{Ia} for fully hardened 13 mm thick plate of 4140 (curves) and plate that did not through-harden (circles), 22 mm thick [4].



W	=	122
W - a	=	80
D	=	25.4 + 1.00 - 0.00
2H	=	153
L	=	150
B_N/B	=	0.75
t	=	3.0

(All dimensions mm)

Fig. 9 Dimensions of compact crack arrest (CCA) test specimen.
(Some specimens did not have side-grooves.)



Fig. 10a Fracture appearance at an elevated temperature (38 C).

top side-grooved
bottom unside-grooved

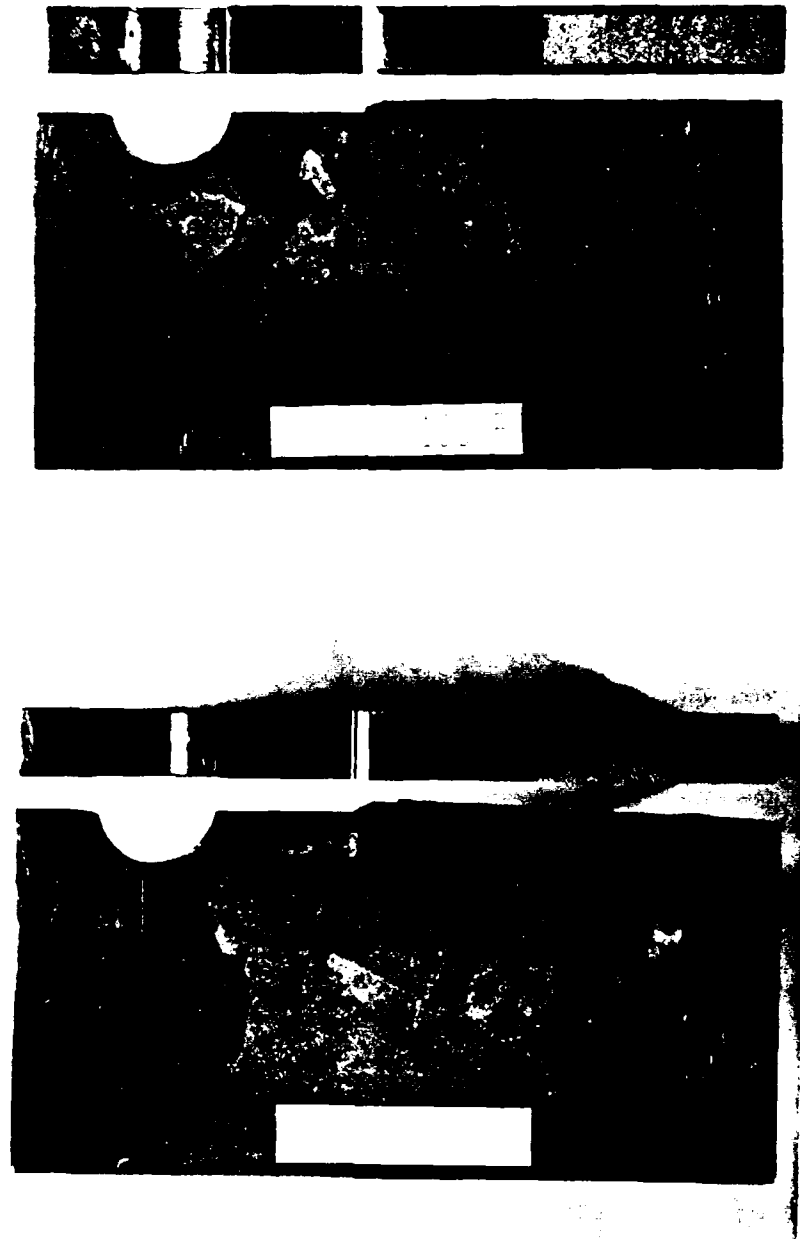

Fig. 10b Fracture appearance at a low temperature (-73 C).

top side-grooved
bottom inside-grooved

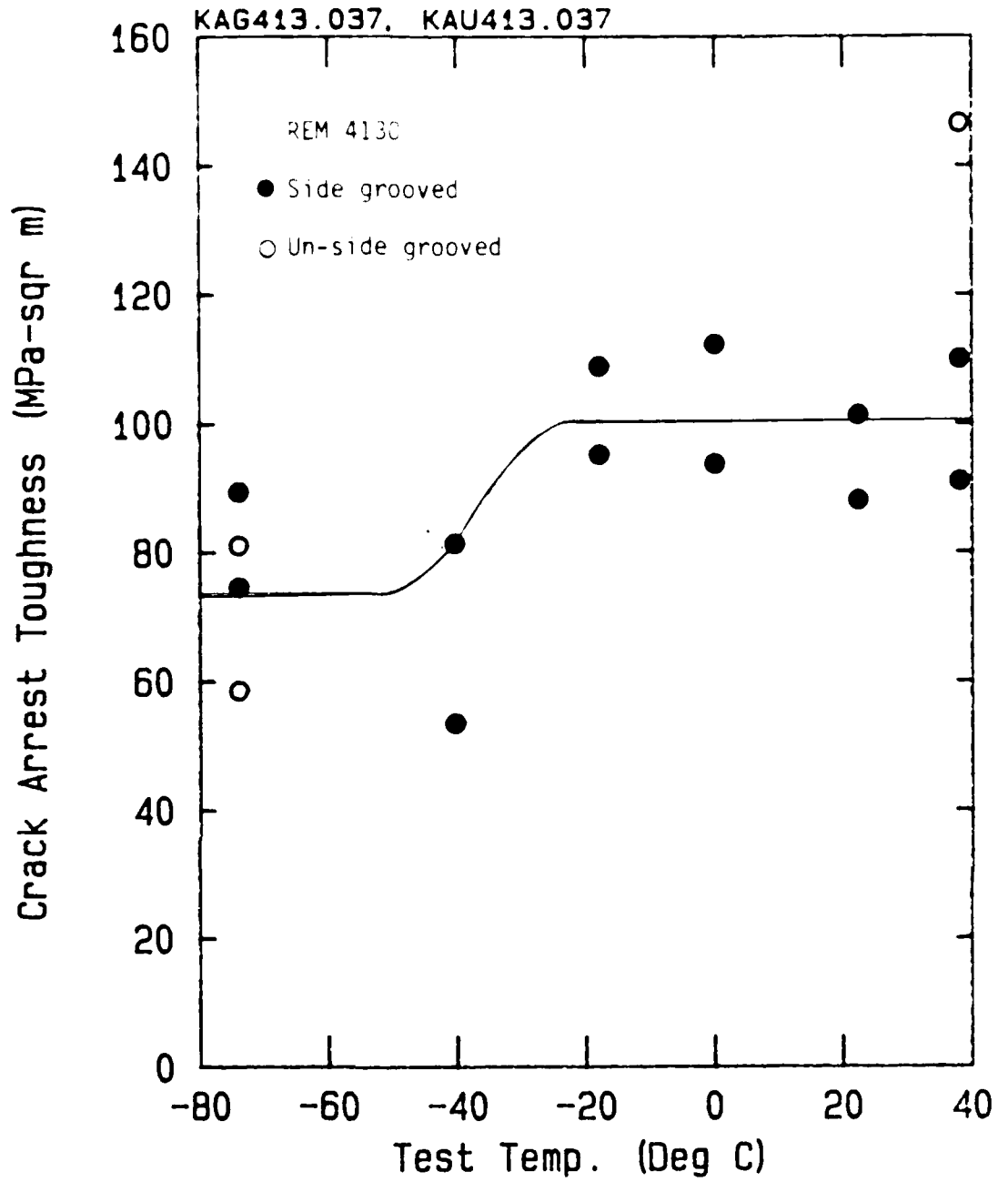

Fig. 11 Crack arrest fracture toughness of REM 4130 steel as a function of test temperature.

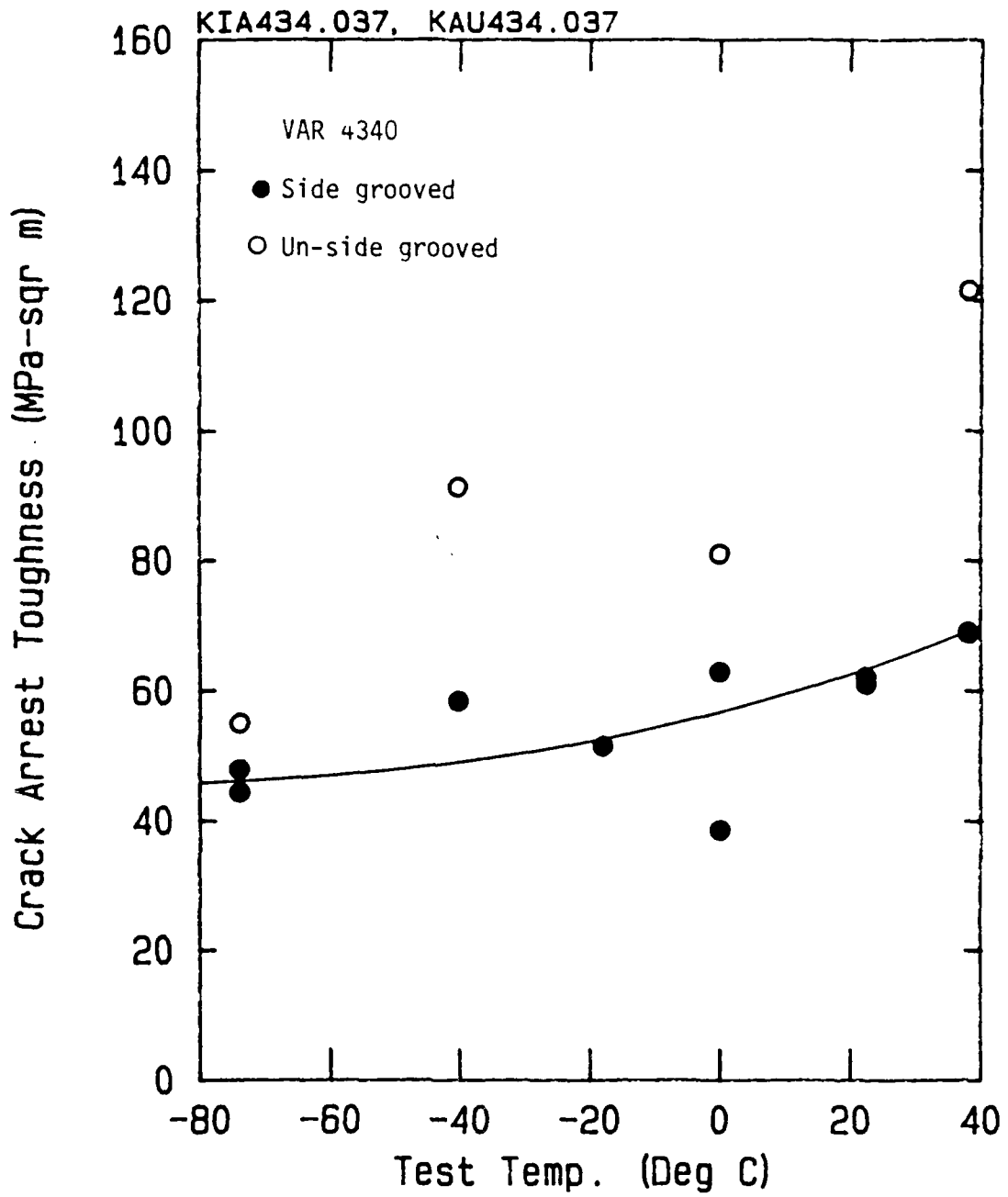

Fig. 12 Crack arrest fracture toughness of VAR 4340 steel as a function of test temperature.



"APPENDIX 1"

Computer Printout Of
Individual Specimen Data

CRACK ARREST FRACTURE TOUGHNESS

COMPACT CRACK ARREST (CCA) SPECIMEN

TEST IDENTIFICATION FILE NAME: 703711
 DATE: 5-2-86
 CUSTOMER OR JOB NO.: 7037
 SPECIMEN NO.: 1-1
 CRACK PLANE ORIENTATION:

MATERIAL

MATERIAL TYPE: 4130
 YOUNG'S MODULUS (KSI): 29000 (200,000 MPa)
 MEASURED YIELD STRENGTH (KSI): 210 (1448 MPa)
 ESTIMATED YIELD STRENGTH (KSI): 0 (0 MPa)

TEST CONDITIONS

TEMPERATURE: 72 F
 ENVIROMENT: AIR

STARTER NOTCH

WAS A BRITTLE WELD USED? IF SO
 WHAT KIND? IF NOT TYPE 'N'. :N
 NOTCH RADIUS, R (MILS): 10 (0.25 mm)

DIMENSIONS

THICKNESS, B (INCHES): .53 (13.5 mm)
 B(N)/B: .75
 WIDTH, W (INCHES): 4.832 (122.7 mm)

CRACK LENGTHS

ORIGINAL CRACK LENGTH, A(O) (INCHES): 1.725 (43.8 mm)
 FINAL CRACK LENGTH, A(F) (INCHES):
 A2 (EDGE): 3.945 (100.2 mm)
 A3 (QUARTER POINT): 3.98 (101.1 mm)
 A4 (CENTER): 3.96 (100.6 mm)
 A5 (QUARTER POINT): 3.965 (100.7 mm)
 A6 (EDGE): 3.945 (100.2 mm)

TEST RECORD

DELTA(O) (INCHES): .05215 (1.32 mm)
 DELTA(F) (INCHES): .0585 (1.49 mm)

1.0 TEST RESULTS:

1.1	K(O) (KSI-SQR(IN))	194.4 (213.7 SI)
1.11	K(O) PLASTIC ZONE CORRECTED (KSI-SQR(IN))	186.5 (205.0 SI)
1.2	K(F) (KSI-SQR(IN))	81.5 (89.6 SI)
1.21	K(F) PLASTIC ZONE CORRECTED (KSI-SQR(IN))	80.2 (88.1 SI)
1.3	PLASTIC ZONE AT INITIATION, RY(O) (IN.)	0.126 (3.2 mm)
1.4	PLASTIC ZONE AT ARREST, RY(F) (IN.)	0.023 (0.6 mm)
1.5	AVERAGE CRACK LENGTH AT ARREST, (IN.)	3.968 (100.8 mm)
1.5	CRACK JUMP DISTANCE, DELTA A (IN.)	2.243 (57.0 mm)
1.6	UNCRACKED LIGAMENT LENGTH, W-AF (IN.)	0.864 (21.9 mm)

2.0 VALIDITY REQUIREMENTS (RATIO >=1):

2.1	PLANE STRAIN, B/(K(F)/YS) ²	3.52
2.2	CRACK JUMP LENGTH, (AF-AO)/RY(O)	17.87
2.3	UNCRACKED LIGAMENT LENGTH, (W-AF)/(8*RY(F))	4.65

CRACK ARREST FRACTURE TOUGHNESS

COMPACT CRACK ARREST (CCA) SPECIMEN

TEST IDENTIFICATION FILE NAME: 703712
 DATE: 5-2-86
 CUSTOMER OR JOB NO.: 7037
 SPECIMEN NO.: 1-2
 CRACK PLANE ORIENTATION:

MATERIAL

MATERIAL TYPE: 4130
 YOUNG'S MODULUS (KSI): 29000 (200,000 MPa)
 MEASURED YIELD STRENGTH (KSI): 210 (1448 MPa)
 ESTIMATED YIELD STRENGTH (KSI): 0 (0 MPa)

TEST CONDITIONS

TEMPERATURE: 32 F
 ENVIROMENT: SILICONE FLUID

STARTER NOTCH

WAS A BRITTLE WELD USED? IF SO
 WHAT KIND? IF NOT TYPE 'N'. :N
 NOTCH RADIUS, R (MILS): 10 (0.25 mm)

DIMENSIONS

THICKNESS, B (INCHES): .535 (13.6 mm)
 B(N)/B: .75
 WIDTH, W (INCHES): 4.83 (122.7 mm)

CRACK LENGTHS

ORIGINAL CRACK LENGTH, A(0) (INCHES): 1.72 (43.7 mm)
 FINAL CRACK LENGTH, A(F) (INCHES):
 A2 (EDGE): 3.755 (95.4 mm)
 A3 (QUARTER POINT): 3.79 (96.3 mm)
 A4 (CENTER): 3.815 (96.9 mm)
 A5 (QUARTER POINT): 3.845 (97.7 mm)
 A6 (EDGE): 3.86 (98.0 mm)

TEST RECORD

DELTA(0) (INCHES): .0525 (1.33 mm)
 DELTA(F) (INCHES): .0564 (1.43 mm)

1.0 TEST RESULTS:

1.1	K(0) (KSI-SQR(IN))	196.1 (215.5 SI)
1.11	K(0) PLASTIC ZONE CORRECTED (KSI-SQR(IN))	187.9 (206.5 SI)
1.2	K(F) (KSI-SQR(IN))	86.8 (95.4 SI)
1.21	K(F) PLASTIC ZONE CORRECTED (KSI-SQR(IN))	85.4 (93.8 SI)
1.3	PLASTIC ZONE AT INITIATION, RY(0) (IN.)	0.127 (3.2 mm)
1.4	PLASTIC ZONE AT ARREST, RY(F) (IN.)	0.026 (0.7 mm)
1.5	AVERAGE CRACK LENGTH AT ARREST, (IN.)	3.817 (96.9 mm)
1.5	CRACK JUMP DISTANCE, DELTA A (IN.)	2.097 (53.3 mm)
1.6	UNCRACKED LIGAMENT LENGTH, W-AF (IN.)	1.013 (25.7 mm)

2.0 VALIDITY REQUIREMENTS (RATIO >=1):

2.1	PLANE STRAIN, B/(K(F)/YS) ²	3.13
2.2	CRACK JUMP LENGTH, (AF-A0)/RY(0)	16.45
2.3	UNCRACKED LIGAMENT LENGTH, (W-AF)/(8*RY(F))	4.82

CRACK ARREST FRACTURE TOUGHNESS

COMPACT CRACK ARREST (CCA) SPECIMEN

TEST IDENTIFICATION FILE NAME: 703713
 DATE: 5-2-86
 CUSTOMER OR JOB NO.: 7037
 SPECIMEN NO.: 1-3
 CRACK PLANE ORIENTATION:

MATERIAL MATERIAL TYPE: 4130
 YOUNG'S MODULUS (KSI): 29000 (200,000 MPa)
 MEASURED YIELD STRENGTH (KSI): 210 (1448 MPa)
 ESTIMATED YIELD STRENGTH (KSI): 0 (0 MPa)

TEST CONDITIONS TEMPERATURE: 0 F
 ENVIROMENT: SILICONE FLUID

STARTER NOTCH WAS A BRITTLE WELD USED? IF SO
 WHAT KIND? IF NOT TYPE 'N'. :N
 NOTCH RADIUS, R (MILS): 10 (0.25 mm)

DIMENSIONS THICKNESS, B (INCHES): .53 (13.5 mm)
 B(N)/B: .75
 WIDTH, W (INCHES): 4.827 (122.6 mm)

CRACK LENGTHS ORIGINAL CRACK LENGTH, A(0) (INCHES): 1.713 (43.5 mm)
 FINAL CRACK LENGTH, A(F) (INCHES):
 A2 (EDGE): 3.738 (94.9 mm)
 A3 (QUARTER POINT): 3.778 (96.0 mm)
 A4 (CENTER): 3.778 (96.0 mm)
 A5 (QUARTER POINT): 3.768 (95.7 mm)
 A6 (EDGE): 3.743 (95.1 mm)

TEST RECORD DELTA(0) (INCHES): .0497 (1.26 mm)
 DELTA(F) (INCHES): .0559 (1.42 mm)

1.0 TEST RESULTS:

1.1 K(0) (KSI-SQR(IN))	186.0 (204.4 SI)
1.11 K(0) PLASTIC ZONE CORRECTED (KSI-SQR(IN))	179.0 (196.7 SI)
1.2 K(F) (KSI-SQR(IN))	88.1 (96.9 SI)
1.21 K(F) PLASTIC ZONE CORRECTED (KSI-SQR(IN))	86.7 (95.3 SI)
1.3 PLASTIC ZONE AT INITIATION, RY(0) (IN.)	0.116 (2.9 mm)
1.4 PLASTIC ZONE AT ARREST, RY(F) (IN.)	0.027 (0.7 mm)
1.5 AVERAGE CRACK LENGTH AT ARREST, (IN.)	3.775 (95.9 mm)
1.5 CRACK JUMP DISTANCE, DELTA A (IN.)	2.062 (52.4 mm)
1.6 UNCRACKED LIGAMENT LENGTH, W-AF (IN.)	1.052 (26.7 mm)

2.0 VALIDITY REQUIREMENTS (RATIO >=1):

2.1 PLANE STRAIN, B/(K(F)/YS)^2	3.01
2.2 CRACK JUMP LENGTH, (AF-A0)/RY(0)	17.83
2.3 UNCRACKED LIGAMENT LENGTH, (W-AF)/(8*RY(F))	4.85

CRACK ARREST FRACTURE TOUGHNESS

COMPACT CRACK ARREST (CCA) SPECIMEN

TEST IDENTIFICATION FILE NAME: 703714
 DATE: 5-5-86
 CUSTOMER OR JOB NO.: 7037
 SPECIMEN NO.: 1-4
 CRACK PLANE ORIENTATION:

MATERIAL MATERIAL TYPE: 4130
 YOUNG'S MODULUS (KSI): 29000 (200,000 MPa)
 MEASURED YIELD STRENGTH (KSI): 210 (1448 MPa)
 ESTIMATED YIELD STRENGTH (KSI): 0 (0 MPa)

TEST CONDITIONS TEMPERATURE: -40 F
 ENVIROMENT: SILICONE FLUID

STARTER NOTCH WAS A BRITTLE WELD USED? IF SO
 WHAT KIND? IF NOT TYPE 'N'. : N
 NOTCH RADIUS, R (MILS): 10 (0.25 mm)

DIMENSIONS THICKNESS, B (INCHES): .534 (13.6 mm)
 B(N)/B: .75
 WIDTH, W (INCHES): 4.826 (122.6 mm)

CRACK LENGTHS ORIGINAL CRACK LENGTH, A(O) (INCHES): 1.718 (43.6 mm)
 FINAL CRACK LENGTH, A(F) (INCHES):
 A2 (EDGE): 4.648 (118.1 mm)
 A3 (QUARTER POINT): 4.673 (118.7 mm)
 A4 (CENTER): 4.668 (118.6 mm)
 A5 (QUARTER POINT): 4.658 (118.3 mm)
 A6 (EDGE): 4.578 (116.3 mm)

TEST RECORD DELTA(O) (INCHES): .0645 (1.64 mm)
 DELTA(F) (INCHES): .0904 (2.30 mm)

1.0 TEST RESULTS:

1.1 K(O) (KSI-SQR(IN))	241.0 (264.9 SI)
1.11 K(O) PLASTIC ZONE CORRECTED (KSI-SQR(IN))	226.6 (249.0 SI)
1.2 K(F) (KSI-SQR(IN))	50.2 (55.1 SI)
1.21 K(F) PLASTIC ZONE CORRECTED (KSI-SQR(IN))	48.7 (53.6 SI)
1.3 PLASTIC ZONE AT INITIATION, RY(O) (IN.)	0.185 (4.7 mm)
1.4 PLASTIC ZONE AT ARREST, RY(F) (IN.)	0.009 (0.2 mm)
1.5 AVERAGE CRACK LENGTH AT ARREST, (IN.)	4.666 (118.5 mm)
1.5 CRACK JUMP DISTANCE, DELTA A (IN.)	2.948 (74.9 mm)
1.6 UNCRACKED LIGAMENT LENGTH, W-AF (IN.)	0.160 (4.1 mm)

2.0 VALIDITY REQUIREMENTS (RATIO >=1):

2.1 PLANE STRAIN, B/(K(F)/YS) ²	9.36
2.2 CRACK JUMP LENGTH, (AF-AO)/RY(O)	15.92
2.3 UNCRACKED LIGAMENT LENGTH, (W-AF)/(8*RY(F))	2.33

CRACK ARREST FRACTURE TOUGHNESS

COMPACT CRACK ARREST (CCA) SPECIMEN

TEST IDENTIFICATION FILE NAME: 703715
 DATE: 5-6-86
 CUSTOMER OR JOB NO.: 7037
 SPECIMEN NO.: 1-5

CRACK PLANE ORIENTATION:

MATERIAL

MATERIAL TYPE: 4130
 YOUNG'S MODULUS (KSI): 29000 (200,000 MPa)
 MEASURED YIELD STRENGTH (KSI): 210 (1448 MPa)
 ESTIMATED YIELD STRENGTH (KSI): 0 (0 MPa)

TEST CONDITIONS

TEMPERATURE: 100 F
 ENVIROMENT: SILICONE FLUID

STARTER NOTCH

WAS A BRITTLE WELD USED? IF SO
 WHAT KIND? IF NOT TYPE 'N'. :N

NOTCH RADIUS, R (MILS): 10 (0.25 mm)

DIMENSIONS

THICKNESS, B (INCHES): .526 (13.4 mm)

B(N)/B: .75

WIDTH, W (INCHES): 4.827 (122.6 mm)

CRACK LENGTHS

ORIGINAL CRACK LENGTH, A(0) (INCHES): 1.717 (43.6 mm)

FINAL CRACK LENGTH, A(F) (INCHES):

A2 (EDGE): 3.652 (92.8 mm)

A3 (QUARTER POINT): 3.697 (93.9 mm)

A4 (CENTER): 3.717 (94.4 mm)

A5 (QUARTER POINT): 3.757 (95.4 mm)

A6 (EDGE): 3.722 (94.5 mm)

TEST RECORD

DELTA(0) (INCHES): .06025 (1.53 mm)

DELTA(F) (INCHES): .06295 (1.60 mm)

1.0 TEST RESULTS:

1.1 K(0) (KSI-SQR(IN)) 225.2 (247.5 SI)

1.11 K(0) PLASTIC ZONE CORRECTED (KSI-SQR(IN)) 213.2 (234.3 SI)

1.2 K(F) (KSI-SQR(IN)) 102.3 (112.5 SI)

1.21 K(F) PLASTIC ZONE CORRECTED (KSI-SQR(IN)) 100.2 (110.1 SI)

1.3 PLASTIC ZONE AT INITIATION, RY(0) (IN.) 0.164 (4.2 mm)

1.4 PLASTIC ZONE AT ARREST, RY(F) (IN.) 0.036 (0.9 mm)

1.5 AVERAGE CRACK LENGTH AT ARREST, (IN.) 3.724 (94.6 mm)

1.5 CRACK JUMP DISTANCE, DELTA A (IN.) 2.007 (51.0 mm)

1.6 UNCRACKED LIGAMENT LENGTH, W-AF (IN.) 1.103 (28.0 mm)

2.0 VALIDITY REQUIREMENTS (RATIO >=1):

2.1 PLANE STRAIN, B/(K(F)/YS)² 2.22

2.2 CRACK JUMP LENGTH, (AF-A0)/RY(0) 12.23

2.3 UNCRACKED LIGAMENT LENGTH, (W-AF)/(B*RY(F)) 3.81

CRACK ARREST FRACTURE TOUGHNESS

COMPACT CRACK ARREST (CCA) SPECIMEN

TEST IDENTIFICATION FILE NAME: 703716
 DATE: 5-6-86
 CUSTOMER OR JOB NO.: 7037
 SPECIMEN NO.: 1-6
 CRACK PLANE ORIENTATION:

MATERIAL MATERIAL TYPE: 4130
 YOUNG'S MODULUS (KSI): 29000 (200,000 MPa)
 MEASURED YIELD STRENGTH (KSI): 210 (1448 MPa)
 ESTIMATED YIELD STRENGTH (KSI): 0 (0 MPa)

TEST CONDITIONS TEMPERATURE: 100 F
 ENVIROMENT: SILICONE FLUID

STARTER NOTCH WAS A BRITTLE WELD USED? IF SO
 WHAT KIND? IF NOT TYPE 'N'. : N
 NOTCH RADIUS, R (MILS): 10 (0.25 mm)

DIMENSIONS THICKNESS, B (INCHES): .53 (13.5 mm)
 B(N)/B: .75
 WIDTH, W (INCHES): 4.825 (122.6 mm)

CRACK LENGTHS ORIGINAL CRACK LENGTH, A(0) (INCHES): 1.715 (43.6 mm)
 FINAL CRACK LENGTH, A(F) (INCHES):
 A2 (EDGE): 4.085 (103.8 mm)
 A3 (QUARTER POINT): 4.075 (103.5 mm)
 A4 (CENTER): 4.075 (103.5 mm)
 A5 (QUARTER POINT): 4.07 (103.4 mm)
 A6 (EDGE): 4.065 (103.3 mm)

TEST RECORD DELTA(0) (INCHES): .0608 (1.54 mm)
 DELTA(F) (INCHES): .06585 (1.67 mm)

- 1.0 TEST RESULTS:
- 1.1 K(0) (KSI-SQR(IN)) 227.4 (249.9 SI)
 - 1.11 K(0) PLASTIC ZONE CORRECTED (KSI-SQR(IN)) 215.1 (236.4 SI)
 - 1.2 K(F) (KSI-SQR(IN)) 84.6 (92.9 SI)
 - 1.21 K(F) PLASTIC ZONE CORRECTED (KSI-SQR(IN)) 82.9 (91.1 SI)
 - 1.3 PLASTIC ZONE AT INITIATION, RY(0) (IN.) 0.167 (4.2 mm)
 - 1.4 PLASTIC ZONE AT ARREST, RY(F) (IN.) 0.025 (0.6 mm)
 - 1.5 AVERAGE CRACK LENGTH AT ARREST, (IN.) 4.073 (103.5 mm)
 - 1.5 CRACK JUMP DISTANCE, DELTA A (IN.) 2.358 (59.9 mm)
 - 1.6 UNCRACKED LIGAMENT LENGTH, W-AF (IN.) 0.752 (19.1 mm)
- 2.0 VALIDITY REQUIREMENTS (RATIO >=1):
- 2.1 PLANE STRAIN, B/(K(F)/YS)² 3.27
 - 2.2 CRACK JUMP LENGTH, (AF-A0)/RY(0) 14.12
 - 2.3 UNCRACKED LIGAMENT LENGTH, (W-AF)/(8*RY(F)) 3.79

CRACK ARREST FRACTURE TOUGHNESS

COMPACT CRACK ARREST (CCA) SPECIMEN

TEST IDENTIFICATION FILE NAME: 703717
 DATE: 5-9-86
 CUSTOMER OR JOB NO.: 7037
 SPECIMEN NO.: 1-7
 CRACK PLANE ORIENTATION:

MATERIAL

MATERIAL TYPE: 4130
 YOUNG'S MODULUS (KSI): 29000 (200,000 MPa)
 MEASURED YIELD STRENGTH (KSI): 210 (1448 MPa)
 ESTIMATED YIELD STRENGTH (KSI): 0 (0 MPa)

TEST CONDITIONS

TEMPERATURE: 0 F
 ENVIRONMENT: SILICONE FLUID

STARTER NOTCH

WAS A BRITTLE WELD USED? IF SO
 WHAT KIND? IF NOT TYPE 'N', :N
 NOTCH RADIUS, R (MILS): 10 (0.25 mm)

DIMENSIONS

THICKNESS, B (INCHES): .53 (13.5 mm)
 B(N)/B: .75
 WIDTH, W (INCHES): 4.844 (123.0 mm)

CRACK LENGTHS

ORIGINAL CRACK LENGTH, A(0) (INCHES): 1.707 (43.4 mm)
 FINAL CRACK LENGTH, A(F) (INCHES):
 A2 (EDGE): 3.025 (76.8 mm)
 A3 (QUARTER POINT): 3.2 (81.3 mm)
 A4 (CENTER): 3.26 (82.8 mm)
 A5 (QUARTER POINT): 3.275 (83.2 mm)
 A6 (EDGE): 3.205 (81.4 mm)

TEST RECORD

DELTA(0) (INCHES): .0452 (1.15 mm)
 DELTA(F) (INCHES): .0483 (1.23 mm)

1.0 TEST RESULTS:

1.1 K(0) (KSI-SQR(IN)) 169.5 (186.3 SI)
 1.11 K(0) PLASTIC ZONE CORRECTED (KSI-SQR(IN)) 164.2 (180.5 SI)
 1.2 K(F) (KSI-SQR(IN)) 100.9 (110.8 SI)
 1.21 K(F) PLASTIC ZONE CORRECTED (KSI-SQR(IN)) 99.2 (109.0 SI)
 1.3 PLASTIC ZONE AT INITIATION, RY(0) (IN.) 0.097 (2.5 mm)
 1.4 PLASTIC ZONE AT ARREST, RY(F) (IN.) 0.036 (0.9 mm)
 1.5 AVERAGE CRACK LENGTH AT ARREST, (IN.) 3.245 (82.4 mm)
 1.5 CRACK JUMP DISTANCE, DELTA A (IN.) 1.538 (39.1 mm)
 1.6 UNCRACKED LIGAMENT LENGTH, W-AF (IN.) 1.599 (40.6 mm)

2.0 VALIDITY REQUIREMENTS (RATIO >=1):

2.1 PLANE STRAIN, B/(K(F)/YS)² 2.30
 2.2 CRACK JUMP LENGTH, (AF-A0)/RY(0) 15.81
 2.3 UNCRACKED LIGAMENT LENGTH, (W-AF)/(8*RY(F)) 5.63

CRACK ARREST FRACTURE TOUGHNESS

COMPACT CRACK ARREST (CCA) SPECIMEN

TEST IDENTIFICATION FILE NAME: 703718
 DATE: 5-12-86
 CUSTOMER OR JOB NO.: 7037
 SPECIMEN NO.: 1-8
 CRACK PLANE ORIENTATION:

MATERIAL MATERIAL TYPE: 4130
 YOUNG'S MODULUS (KSI): 29000 (200,000 MPa)
 MEASURED YIELD STRENGTH (KSI): 210 (1448 MPa)
 ESTIMATED YIELD STRENGTH (KSI): 0 (0 MPa)

TEST CONDITIONS TEMPERATURE: -40 F
 ENVIROMENT: SILICONE FLUID

STARTER NOTCH
 WAS A BRITTLE WELD USED? IF SO
 WHAT KIND? IF NOT TYPE 'N'. :N
 NOTCH RADIUS, R (MILS): 10 (0.25 mm)

DIMENSIONS THICKNESS, B (INCHES): .528 (13.4 mm)
 B(N)/B: .75
 WIDTH, W (INCHES): 4.844 (123.0 mm)

CRACK LENGTHS ORIGINAL CRACK LENGTH, A(0) (INCHES): 1.705 (43.3 mm)
 FINAL CRACK LENGTH, A(F) (INCHES):
 A2 (EDGE): 3.905 (99.2 mm)
 A3 (QUARTER POINT): 3.91 (99.3 mm)
 A4 (CENTER): 3.885 (98.7 mm)
 A5 (QUARTER POINT): 3.85 (97.8 mm)
 A6 (EDGE): 3.77 (95.8 mm)

TEST RECORD DELTA(0) (INCHES): .0449 (1.14 mm)
 DELTA(F) (INCHES): .05056 (1.28 mm)

- 1.0 TEST RESULTS:
- 1.1 K(0) (KSI-SQR(IN)) 168.5 (185.2 SI)
 - 1.11 K(0) PLASTIC ZONE CORRECTED (KSI-SQR(IN)) 163.3 (179.4 SI)
 - 1.2 K(F) (KSI-SQR(IN)) 75.1 (82.5 SI)
 - 1.21 K(F) PLASTIC ZONE CORRECTED (KSI-SQR(IN)) 74.1 (81.4 SI)
 - 1.3 PLASTIC ZONE AT INITIATION, RY(0) (IN.) 0.096 (2.4 mm)
 - 1.4 PLASTIC ZONE AT ARREST, RY(F) (IN.) 0.020 (0.5 mm)
 - 1.5 AVERAGE CRACK LENGTH AT ARREST, (IN.) 3.882 (98.6 mm)
 - 1.5 CRACK JUMP DISTANCE, DELTA A (IN.) 2.177 (55.3 mm)
 - 1.6 UNCRACKED LIGAMENT LENGTH, W-AF (IN.) 0.962 (24.4 mm)
- 2.0 VALIDITY REQUIREMENTS (RATIO >=1):
- 2.1 PLANE STRAIN, B/(K(F)/YS)² 4.13
 - 2.2 CRACK JUMP LENGTH, (AF-A0)/RY(0) 22.62
 - 2.3 UNCRACKED LIGAMENT LENGTH, (W-AF)/(8*RY(F)) 6.07

CRACK ARREST FRACTURE TOUGHNESS

COMPACT CRACK ARREST (CCA) SPECIMEN

TEST IDENTIFICATION FILE NAME: 703719
 DATE: 5-8-86
 CUSTOMER OR JOB NO.: 7037
 SPECIMEN NO.: 1-9
 CRACK PLANE ORIENTATION:

MATERIAL

MATERIAL TYPE: 4130
 YOUNG'S MODULUS (KSI): 29000 (200,000 MPa)
 MEASURED YIELD STRENGTH (KSI): 210 (1448 MPa)
 ESTIMATED YIELD STRENGTH (KSI): 0 (0 MPa)

TEST CONDITIONS

TEMPERATURE: 72 F
 ENVIROMENT: SILICONE FLUID

STARTER NOTCH

WAS A BRITTLE WELD USED? IF SO
 WHAT KIND? IF NOT TYPE 'N'. :N
 NOTCH RADIUS, R (MILS): 10 (0.25 mm)

DIMENSIONS

THICKNESS, B (INCHES): .532 (13.5 mm)
 B(N)/B: .75
 WIDTH, W (INCHES): 4.83 (122.7 mm)

CRACK LENGTHS

ORIGINAL CRACK LENGTH, A(O) (INCHES): 1.7 (43.2 mm)
 FINAL CRACK LENGTH, A(F) (INCHES):
 A2 (EDGE): 3.62 (91.9 mm)
 A3 (QUARTER POINT): 3.63 (92.2 mm)
 A4 (CENTER): 3.615 (91.8 mm)
 A5 (QUARTER POINT): 3.585 (91.1 mm)
 A6 (EDGE): 3.505 (89.0 mm)

TEST RECORD

DELTA(O) (INCHES): .052 (1.32 mm)
 DELTA(F) (INCHES): .0541 (1.37 mm)

1.0 TEST RESULTS:

1.1 K(O) (KSI-SQR(IN))	195.5 (214.8 SI)
1.11 K(O) PLASTIC ZONE CORRECTED (KSI-SQR(IN))	187.4 (206.0 SI)
1.2 K(F) (KSI-SQR(IN))	93.9 (103.1 SI)
1.21 K(F) PLASTIC ZONE CORRECTED (KSI-SQR(IN))	92.3 (101.4 SI)
1.3 PLASTIC ZONE AT INITIATION, RY(O) (IN.)	0.127 (3.2 mm)
1.4 PLASTIC ZONE AT ARREST, RY(F) (IN.)	0.031 (0.8 mm)
1.5 AVERAGE CRACK LENGTH AT ARREST, (IN.)	3.610 (91.7 mm)
1.5 CRACK JUMP DISTANCE, DELTA A (IN.)	1.910 (48.5 mm)
1.6 UNCRACKED LIGAMENT LENGTH, W-AF (IN.)	1.220 (31.0 mm)

2.0 VALIDITY REQUIREMENTS (RATIO >=1):

2.1 PLANE STRAIN, B/(K(F)/YS) ²	2.66
2.2 CRACK JUMP LENGTH, (AF-AO)/RY(O)	15.07
2.3 UNCRACKED LIGAMENT LENGTH, (W-AF)/(B*RY(F))	4.96

CRACK ARREST FRACTURE TOUGHNESS

COMPACT CRACK ARREST (CCA) SPECIMEN

TEST IDENTIFICATION FILE NAME: 037110
 DATE: 5-16-86
 CUSTOMER OR JOB NO.: 7037
 SPECIMEN NO.: 1-10
 CRACK PLANE ORIENTATION:

MATERIAL
 MATERIAL TYPE: 4130
 YOUNG'S MODULUS (KSI): 29000 (200,000 MPa)
 MEASURED YIELD STRENGTH (KSI): 210 (1448 MPa)
 ESTIMATED YIELD STRENGTH (KSI): 0 (0 MPa)

TEST CONDITIONS
 TEMPERATURE: -100 F
 ENVIROMENT: N2

STARTER NOTCH
 WAS A BRITTLE WELD USED? IF SO
 WHAT KIND? IF NOT TYPE 'N'. :N
 NOTCH RADIUS, R (MILS): 10 (0.25 mm)

DIMENSIONS
 THICKNESS, B (INCHES): .533 (13.5 mm)
 B(N)/B: 1
 WIDTH, W (INCHES): 4.826 (122.6 mm)

CRACK LENGTHS
 ORIGINAL CRACK LENGTH, A(O) (INCHES): 1.691 (43.0 mm)
 FINAL CRACK LENGTH, A(F) (INCHES):
 A2 (EDGE): 4.249 (107.9 mm)
 A3 (QUARTER POINT): 4.505 (114.4 mm)
 A4 (CENTER): 4.53 (115.1 mm)
 A5 (QUARTER POINT): 4.515 (114.7 mm)
 A6 (EDGE): 4.305 (109.3 mm)

TEST RECORD
 DELTA(O) (INCHES): .054 (1.37 mm)
 DELTA(F) (INCHES): .07985 (2.03 mm)

1.0 TEST RESULTS:

1.1 K(O) (KSI-SQR(IN))	176.3 (193.7 SI)
1.11 K(O) PLASTIC ZONE CORRECTED (KSI-SQR(IN))	170.3 (187.2 SI)
1.2 K(F) (KSI-SQR(IN))	54.2 (59.6 SI)
1.21 K(F) PLASTIC ZONE CORRECTED (KSI-SQR(IN))	53.3 (58.5 SI)
1.3 PLASTIC ZONE AT INITIATION, RY(O) (IN.)	0.105 (2.7 mm)
1.4 PLASTIC ZONE AT ARREST, RY(F) (IN.)	0.010 (0.3 mm)
1.5 AVERAGE CRACK LENGTH AT ARREST, (IN.)	4.517 (114.7 mm)
1.5 CRACK JUMP DISTANCE, DELTA A (IN.)	2.826 (71.8 mm)
1.6 UNCRACKED LIGAMENT LENGTH, W-AF (IN.)	0.309 (7.9 mm)

2.0 VALIDITY REQUIREMENTS (RATIO >=1):

2.1 PLANE STRAIN, B/(K(F)/YS) ²	8.00
2.2 CRACK JUMP LENGTH, (AF-AO)/RY(O)	26.99
2.3 UNCRACKED LIGAMENT LENGTH, (W-AF)/(B*RY(F))	3.78

CRACK ARREST FRACTURE TOUGHNESS

COMPACT CRACK ARREST (CCA) SPECIMEN

TEST IDENTIFICATION FILE NAME: 037111
 DATE: 5-19-86
 CUSTOMER OR JOB NO.: 7037
 SPECIMEN NO.: 1-11
 CRACK PLANE ORIENTATION:

MATERIAL

MATERIAL TYPE: 4130
 YOUNG'S MODULUS (KSI): 29000 (200,000 MPa)
 MEASURED YIELD STRENGTH (KSI): 210 (1448 MPa)
 ESTIMATED YIELD STRENGTH (KSI): 0 (0 MPa)

TEST CONDITIONS

TEMPERATURE: -100 F
 ENVIROMENT: N2

STARTER NOTCH

WAS A BRITTLE WELD USED? IF SO
 WHAT KIND? IF NOT TYPE 'N'. :N
 NOTCH RADIUS, R (MILS): 10 (0.25 mm)

DIMENSIONS

THICKNESS, B (INCHES): .53 (13.5 mm)
 B(N)/B: .75
 WIDTH, W (INCHES): 4.83 (122.7 mm)

CRACK LENGTHS

ORIGINAL CRACK LENGTH, A(0) (INCHES): 1.697 (43.1 mm)
 FINAL CRACK LENGTH, A(F) (INCHES):
 A2 (EDGE): 2.83 (71.9 mm)
 A3 (QUARTER POINT): 2.98 (75.7 mm)
 A4 (CENTER): 2.98 (75.7 mm)
 A5 (QUARTER POINT): 2.975 (75.6 mm)
 A6 (EDGE): 2.91 (73.9 mm)

TEST RECORD

DELTA(0) (INCHES): .02788 (0.71 mm)
 DELTA(F) (INCHES): .0351 (0.89 mm)

1.0 TEST RESULTS:

1.1 K(0) (KSI-SQR(IN))	104.9 (115.3 SI)
1.11 K(0) PLASTIC ZONE CORRECTED (KSI-SQR(IN))	103.6 (113.8 SI)
1.2 K(F) (KSI-SQR(IN))	82.2 (90.4 SI)
1.21 K(F) PLASTIC ZONE CORRECTED (KSI-SQR(IN))	81.4 (89.5 SI)
1.3 PLASTIC ZONE AT INITIATION, RY(0) (IN.)	0.039 (1.0 mm)
1.4 PLASTIC ZONE AT ARREST, RY(F) (IN.)	0.024 (0.6 mm)
1.5 AVERAGE CRACK LENGTH AT ARREST, (IN.)	2.978 (75.6 mm)
1.5 CRACK JUMP DISTANCE, DELTA A (IN.)	1.281 (32.5 mm)
1.6 UNCRACKED LIGAMENT LENGTH, W-AF (IN.)	1.852 (47.0 mm)

2.0 VALIDITY REQUIREMENTS (RATIO >=1):

2.1 PLANE STRAIN, B/(K(F)/YS) ²	3.46
2.2 CRACK JUMP LENGTH, (AF-A0)/RY(0)	33.09
2.3 UNCRACKED LIGAMENT LENGTH, (W-AF)/(8*RY(F))	9.68

CRACK ARREST FRACTURE TOUGHNESS

COMPACT CRACK ARREST (CCA) SPECIMEN

TEST IDENTIFICATION FILE NAME: 037112
 DATE: 5-19-86
 CUSTOMER OR JOB NO.: 7037
 SPECIMEN NO.: 1-12
 CRACK PLANE ORIENTATION:

MATERIAL MATERIAL TYPE: 4130
 YOUNG'S MODULUS (KSI): 29000 (200,000 MPa)
 MEASURED YIELD STRENGTH (KSI): 210 (1448 MPa)
 ESTIMATED YIELD STRENGTH (KSI): 0 (0 MPa)

TEST CONDITIONS TEMPERATURE: -100 F
 ENVIROMENT: N2

STARTER NOTCH
 WAS A BRITTLE WELD USED? IF SO
 WHAT KIND? IF NOT TYPE 'N'. :N
 NOTCH RADIUS, R (MILS): 10 (0.25 mm)

DIMENSIONS THICKNESS, B (INCHES): .529 (13.4 mm)
 B(N)/B: 1
 WIDTH, W (INCHES): 4.831 (122.7 mm)

CRACK LENGTHS ORIGINAL CRACK LENGTH, A(0) (INCHES): 1.696 (43.1 mm)
 FINAL CRACK LENGTH, A(F) (INCHES):
 A2 (EDGE): 3.115 (79.1 mm)
 A3 (QUARTER POINT): 3.37 (85.6 mm)
 A4 (CENTER): 3.35 (85.1 mm)
 A5 (QUARTER POINT): 3.305 (83.9 mm)
 A6 (EDGE): 2.97 (75.4 mm)

TEST RECORD DELTA(0) (INCHES): .0374 (0.95 mm)
 DELTA(F) (INCHES): .04325 (1.10 mm)

1.0 TEST RESULTS:
 1.1 K(0) (KSI-SQR(IN)) 121.9 (134.0 SI)
 1.11 K(0) PLASTIC ZONE CORRECTED (KSI-SQR(IN)) 119.9 (131.7 SI)
 1.2 K(F) (KSI-SQR(IN)) 74.5 (81.9 SI)
 1.21 K(F) PLASTIC ZONE CORRECTED (KSI-SQR(IN)) 73.8 (81.1 SI)
 1.3 PLASTIC ZONE AT INITIATION, RY(0) (IN.) 0.052 (1.3 mm)
 1.4 PLASTIC ZONE AT ARREST, RY(F) (IN.) 0.020 (0.5 mm)
 1.5 AVERAGE CRACK LENGTH AT ARREST, (IN.) 3.342 (84.9 mm)
 1.5 CRACK JUMP DISTANCE, DELTA A (IN.) 1.646 (41.8 mm)
 1.6 UNCRACKED LIGAMENT LENGTH, W-AF (IN.) 1.489 (37.8 mm)
 2.0 VALIDITY REQUIREMENTS (RATIO >=1):
 2.1 PLANE STRAIN, B/(K(F)/YS)² 4.20
 2.2 CRACK JUMP LENGTH, (AF-A0)/RY(0) 31.74
 2.3 UNCRACKED LIGAMENT LENGTH, (W-AF)/(B*RY(F)) 9.46

CRACK ARREST FRACTURE TOUGHNESS

CONTACT CRACK ARREST (CCA) SPECIMEN

TEST IDENTIFICATION FILE NAME: 037113
 DATE: 5-13-86
 CUSTOMER OR JOB NO.: 7037
 SPECIMEN NO.: 1-13
 CRACK PLANE ORIENTATION:

MATERIAL MATERIAL TYPE: 4130
 YOUNG'S MODULUS (KSI): 29000 (200,000 MPa)
 MEASURED YIELD STRENGTH (KSI): 210 (1448 MPa)
 ESTIMATED YIELD STRENGTH (KSI): 0 (0 MPa)

TEST CONDITIONS TEMPERATURE: -100 F
 ENVIROMENT: N2

STARTER NOTCH WAS A BRITTLE WELD USED? IF SO
 WHAT KIND? IF NOT TYPE 'N'. :N
 NOTCH RADIUS, R (MILS): 10 (0.25 mm)

DIMENSIONS THICKNESS, B (INCHES): .532 (13.5 mm)
 B(N)/B: .75
 WIDTH, W (INCHES): 4.829 (122.7 mm)

CRACK LENGTHS ORIGINAL CRACK LENGTH, A(O) (INCHES): 1.7 (43.2 mm)
 FINAL CRACK LENGTH, A(F) (INCHES):
 A2 (EDGE): 2.945 (74.8 mm)
 A3 (QUARTER POINT): 2.975 (75.6 mm)
 A4 (CENTER): 2.99 (75.9 mm)
 A5 (QUARTER POINT): 3.005 (76.3 mm)
 A6 (EDGE): 2.99 (75.9 mm)

TEST RECORD DELTA(O) (INCHES): .02532 (0.64 mm)
 DELTA(F) (INCHES): .02935 (0.75 mm)

1.0 TEST RESULTS:
 1.1 K(O) (KSI-SQR(IN)) 95.2 (104.6 SI)
 1.11 K(O) PLASTIC ZONE CORRECTED (KSI-SQR(IN)) 94.2 (103.5 SI)
 1.2 K(F) (KSI-SQR(IN)) 68.4 (75.2 SI)
 1.21 K(F) PLASTIC ZONE CORRECTED (KSI-SQR(IN)) 67.9 (74.6 SI)
 1.3 PLASTIC ZONE AT INITIATION, RY(O) (IN.) 0.032 (0.8 mm)
 1.4 PLASTIC ZONE AT ARREST, RY(F) (IN.) 0.017 (0.4 mm)
 1.5 AVERAGE CRACK LENGTH AT ARREST, (IN.) 2.990 (75.9 mm)
 1.5 CRACK JUMP DISTANCE, DELTA A (IN.) 1.290 (32.8 mm)
 1.6 UNCRACKED LIGAMENT LENGTH, W-AF (IN.) 1.839 (46.7 mm)
 2.0 VALIDITY REQUIREMENTS (RATIO >=1):
 2.1 PLANE STRAIN, B/(K(F)/YS)² 5.01
 2.2 CRACK JUMP LENGTH, (AF-AO)/RY(O) 40.30
 2.3 UNCRACKED LIGAMENT LENGTH, (W-AF)/(B*RY(F)) 13.81

CRACK ARREST FRACTURE TOUGHNESS

COMPACT CRACK ARREST (CCA) SPECIMEN

TEST IDENTIFICATION FILE NAME: 037115
 DATE: 5-6-86
 CUSTOMER OR JOB NO.: 7037
 SPECIMEN NO.: 1-15
 CRACK PLANE ORIENTATION:

MATERIAL

MATERIAL TYPE: 4130
 YOUNG'S MODULUS (KSI): 29000 (200,000 MPa)
 MEASURED YIELD STRENGTH (KSI): 210 (1448 MPa)
 ESTIMATED YIELD STRENGTH (KSI): 0 (0 MPa)

TEST CONDITIONS

TEMPERATURE: 100 F
 ENVIROMENT: SILICONE FLUID

STARTER NOTCH

WAS A BRITTLE WELD USED? IF SO
 WHAT KIND? IF NOT TYPE 'N'. :N
 NOTCH RADIUS, R (MILS): 10 (0.25 mm)

DIMENSIONS

THICKNESS, B (INCHES): .53 (13.5 mm)
 B(N)/B: 1
 WIDTH, W (INCHES): 4.831 (122.7 mm)

CRACK LENGTHS

ORIGINAL CRACK LENGTH, A(O) (INCHES): 1.697 (43.1 mm)
 FINAL CRACK LENGTH, A(F) (INCHES):
 A2 (EDGE): 2.495 (63.4 mm)
 A3 (QUARTER POINT): 2.94 (74.7 mm)
 A4 (CENTER): 3.005 (76.3 mm)
 A5 (QUARTER POINT): 2.99 (75.9 mm)
 A6 (EDGE): 2.435 (61.8 mm)

TEST RECORD

DELTA(O) (INCHES): .06547 (1.66 mm)
 DELTA(F) (INCHES): .06765 (1.72 mm)

1.0 TEST RESULTS:

1.1 K(O) (KSI-SQR(IN))	213.3 (234.5 SI)
1.11 K(O) PLASTIC ZONE CORRECTED (KSI-SQR(IN))	203.1 (223.2 SI)
1.2 K(F) (KSI-SQR(IN))	137.3 (150.9 SI)
1.21 K(F) PLASTIC ZONE CORRECTED (KSI-SQR(IN))	133.5 (146.8 SI)
1.3 PLASTIC ZONE AT INITIATION, RY(O) (IN.)	0.149 (3.8 mm)
1.4 PLASTIC ZONE AT ARREST, RY(F) (IN.)	0.064 (1.6 mm)
1.5 AVERAGE CRACK LENGTH AT ARREST, (IN.)	2.978 (75.6 mm)
1.5 CRACK JUMP DISTANCE, DELTA A (IN.)	1.281 (32.5 mm)
1.6 UNCRACKED LIGAMENT LENGTH, W-AF (IN.)	1.853 (47.1 mm)

2.0 VALIDITY REQUIREMENTS (RATIO >=1):

2.1 PLANE STRAIN, B/(K(F)/YS) ²	1.24
2.2 CRACK JUMP LENGTH, (AF-AO)/RY(O)	8.61
2.3 UNCRACKED LIGAMENT LENGTH, (W-AF)/(B*RY(F))	3.60

CRACK ARREST FRACTURE TOUGHNESS

COMPACT CRACK ARREST (CCA) SPECIMEN

TEST IDENTIFICATION FILE NAME: 037116
 DATE: 5-8-86
 CUSTOMER OR JOB NO.: 7037
 SPECIMEN NO.: 1-16
 CRACK PLANE ORIENTATION:

MATERIAL

MATERIAL TYPE: 4130
 YOUNG'S MODULUS (KSI): 29000 (200,000 MPa)
 MEASURED YIELD STRENGTH (KSI): 210 (1448 MPa)
 ESTIMATED YIELD STRENGTH (KSI): 0 (0 MPa)

TEST CONDITIONS

TEMPERATURE: 32 F
 ENVIROMENT: SILICONE FLUID

STARTER NOTCH

WAS A BRITTLE WELD USED? IF SO
 WHAT KIND? IF NOT TYPE 'N'. :N
 NOTCH RADIUS, R (MILS): 10 (0.25 mm)

DIMENSIONS

THICKNESS, B (INCHES): .524 (13.3 mm)
 B(N)/B: .75
 WIDTH, W (INCHES): 4.831 (122.7 mm)

CRACK LENGTHS

ORIGINAL CRACK LENGTH, A(0) (INCHES): 1.702 (43.2 mm)
 FINAL CRACK LENGTH, A(F) (INCHES):
 A2 (EDGE): 3.425 (87.0 mm)
 A3 (QUARTER POINT): 3.415 (86.7 mm)
 A4 (CENTER): 3.41 (86.6 mm)
 A5 (QUARTER POINT): 3.4 (86.4 mm)
 A6 (EDGE): 3.395 (86.2 mm)

TEST RECORD

DELTA(0) (INCHES): .05132 (1.30 mm)
 DELTA(F) (INCHES): .0541 (1.37 mm)

1.0 TEST RESULTS:

1.1	K(0) (KSI-SQR(IN))	192.8 (211.9 SI)
1.11	K(0) PLASTIC ZONE CORRECTED (KSI-SQR(IN))	185.1 (203.4 SI)
1.2	K(F) (KSI-SQR(IN))	104.2 (114.5 SI)
1.21	K(F) PLASTIC ZONE CORRECTED (KSI-SQR(IN))	102.3 (112.4 SI)
1.3	PLASTIC ZONE AT INITIATION, RY(0) (IN.)	0.124 (3.1 mm)
1.4	PLASTIC ZONE AT ARREST, RY(F) (IN.)	0.038 (1.0 mm)
1.5	AVERAGE CRACK LENGTH AT ARREST, (IN.)	3.408 (86.6 mm)
1.5	CRACK JUMP DISTANCE, DELTA A (IN.)	1.706 (43.3 mm)
1.6	UNCRACKED LIGAMENT LENGTH, W-AF (IN.)	1.423 (36.1 mm)

2.0 VALIDITY REQUIREMENTS (RATIO ≥ 1):

2.1	PLANE STRAIN, B/(K(F)/YS) ²	2.13
2.2	CRACK JUMP LENGTH, (AF-A0)/RY(0)	13.81
2.3	UNCRACKED LIGAMENT LENGTH, (W-AF)/(8*RY(F))	4.71



"APPENDIX 2"

Test Method Used to Measure the
Crack Arrest Fracture Toughness
of High Strength Metals



1.0 INTRODUCTION

ASTM is presently balloting a "PROPOSED ASTM STANDARD TEST METHOD FOR DETERMINING THE PLANE STRAIN CRACK ARREST FRACTURE TOUGHNESS, K_{Ia} , OF FERRITIC MATERIALS". This method is generally directed toward very thick, intermediate strength steels of the type used in nuclear reactor pressure vessels. The procedure described in this appendix extracts the information in this method that is applicable to high strength metals having a ratio (K_a /yield strength)² that is considerably less than unity. This restriction eliminates some of the testing, and analytical complexities that are associated with the more general method.

2.0 SUMMARY OF METHOD

This test method evaluates the stress intensity factor at which a fast running crack will arrest. The test is made by forcing a wedge into a split pin which develops an opening force across the crack face of a compact type specimen causing a run-arrest segment of crack extension.

Certain specimen size requirements must be maintained: The in-plane dimensions must be large enough to allow the specimen to be analyzed by elastic methods. Testing is done on full thickness plates so that a condition of plane strain may not be developed, but it generally will for the high strength metals that are the subject of this method. The minimum in-plane specimen dimensions are a function of the crack arrest toughness and the yield strength so that a range of specimen sizes is provided.

During the earlier portion of the run arrest event, dynamic effects are large because of the abrupt acceleration of the



initially stationary crack tip. During the later portions of the event, while the crack velocity decreases toward arrest, these dynamic effects become negligible so that the value of K at the moment of arrest can be calculated by equations that have been established on the basis of a static elastic stress analysis of the compact specimen.

Since only the arrest toughness is being evaluated, the method is independent of the manner in which the crack is initiated.

Calculation of the initiation toughness is based on measurements of the machined notch length and displacement at initiation. The arrest toughness is based on the measurements of crack length and displacement at arrest.

3.0 SIGNIFICANCE

The significance of the test with respect to armor behavior has not been established as yet. It is expected, however, that the crack arrest fracture toughness values will assist in selecting armor materials so as to have a minimum area of shatter and a minimal amount of cracking.

The parameter K_a may also be useful as a material parameter for computer modeling armor behavior.

4.0 DEFINITIONS

4.1 Stress intensity at crack initiation, K_0 ($FL^{-3/2}$)--the value of K calculated on the basis of the original, machined crack length, and the critical displacement at which the run-arrest segment of crack extension is initiated.



Note: Since cracks are initiated from machined, relatively blunt notches, the singularity associated with a sharp notch does not exist. Nevertheless, the pseudo K-value is calculated for initiation in order to have a measure of the driving force used to start the event. K_0 is not a material property, but is a function of the type of starter notch used.

4.2 Crack arrest toughness, CAT, $FL^{-3/2}$ --the value of K_1 calculated on the basis of the crack length and displacement at arrest.

4.2.1 Plane strain crack arrest toughness, K_{Ia} , $FL^{-3/2}$ --the value of CAT for a crack extending under a condition of crack-tip plane strain. Full thickness plates are tested in this method. Whether or not a condition of plane strain is attained is specified by the definition in Section 8.4.

5.0 APPARATUS

5.1 The procedure involves testing of compact specimens that have been notched by machining. Because the load required to start a crack from the machined notch is large compared with the load needed to maintain extension after a natural crack forms, the loading system must have a low compliance compared with the test specimen. Hence, a wedge and split pin assembly are used to apply a load on the crack line. This loading arrangement does not permit easy measurement of opening loads, so that displacement measurements are used for calculating K_0 and K_a .

5.2 Loading Train - A typical loading train is shown in Figure 1. The specimen is mounted on a base block that contains a hole that is aligned with the specimen hole. The load that forces the wedge into the split pin is transmitted through a load cell.



5.2.1 Lubricant should be provided between the base-plate and specimen. Sheet or tapes of TFE-fluorocarbon, heavy oils or dry lubricants can be used.

5.2.2 A low taper-angle wedge with a polished finish and split pin arrangement is used. The dimensions of a wedge and split-pin assembly that has been found satisfactory for a specimen containing a 25.4 mm hole is shown in Figure 2.

The split-pin must be long enough to contact the full specimen thickness, and the diameter large enough to avoid upsetting the test specimen. The wedge must be long enough to develop the maximum expected crack-opening displacement. Any air or oil hardening tool steel is suitable for making the wedge and a hard bronze is recommended for the split pins. A hardness in the range 45 to 55 R_C has been used for the wedge.

The wedge, split-pin and specimen hole should be lubricated. Wrapping the wedge and split-pin with TFE-fluorocarbon tape has been found to be satisfactory. With the small wedge angle and proper lubrication, a loading machine producing 1/5 or 1/10 the expected maximum opening load is adequate.

5.3 Displacement Gages - Displacement gages are used to accurately measure the crack-opening displacement at 0.25W from the load-line. The gage recommended in Method E399 is satisfactory. However, it is necessary to attach the gage in a fashion such that it will not lose contact with the specimen during the run-arrest event. A method that has proven satisfactory for doing this is shown in Figure 3. Other gages might be used so long as their precision is consistent with the calibration procedure outlined in of Method E399. Absolute accuracy within two percent over the working range is required.



6.0 Specimen Configuration, Dimensions, and Preparation

6.1 Standard Specimen - The geometry of a compact crack arrest (CCA) specimen that is satisfactory for high steels is shown in Figure 3.

6.1.1 The thickness, B. shall be full product plate thickness.

6.1.2 Side grooves shall be used. These have a root radius of 0.010 in (0.25 mm), a 45° included angle, and a depth = B/8 per side.

6.1.3 The specimen width, W. shall not be less than 2B.

6.1.4 The loading hole diameter, D, shall be within the range $0.25W \leq D \leq 0.5W$.

6.1.5 The length of the crack starter notch, a_0 , shall be within the range $0.30W \leq a_0 \leq 0.35W$.

6.1.6 The displacement gage centerline shall be at an offset by 0.25W.

6.2 Specimen Dimensions - In order for a measurement of K_a (or K_{Ia}) to be valid by this method, the size requirements of 8.3 (and 8.4) must be met. The minimum allowable specimen depth, W. is therefore determined by the value of K_a (or K_{Ia}) to be measured. The K_a (or K_{Ia}) measurement capacity is approximately $0.6 (\sigma_{ys} + \sigma_0) \sqrt{W}$ where σ_{ys} and σ_0 are as defined in 8.3.2.

6.2.1 For a plane strain test the specimen thickness, B. must meet the requirement of 8.4.



6.3 Starting Notch - The function of the starting notch is to produce crack initiation at a load line displacement (or wedging force) which will cause the crack to arrest after an appropriate length of extension. It is convenient to express the crack initiation condition in terms of a formally calculated stress intensity factor, K_o , based on the crack line displacement and the initial machine notch length. A machined notch rather than a fatigue pre-crack is used.

7.0 Procedure

7.1 Number of Tests - It is recommended that at least three replicate tests be made.

7.2 Specimen Measurement - Measure the thickness, B , and the crack plane width, B_N to $\pm 1\%$ of B at four locations between the end of the machined notch crack starter and the unnotched edge of the specimen. Measure the specimen width, W , to $\pm 0.5\%$ of W .

7.3 Preliminary Calculations - In order to meet the requirement of 8.3 the value of K_o should be limited to $0.75 (\sigma_{ys} + \sigma_o) \sqrt{W}$. To achieve this the displacement, V_o , should be limited to $V_o < [K_o \sqrt{W/Ef} (a/w)] (B_N/B)^{1/2}$ where the terms are as defined in 8.2. This initial displacement will permit K_a measurement between approximately $0.25 (\sigma_{ys} + \sigma_o) \sqrt{W}$ and $0.60 (\sigma_{ys} + \sigma_o) \sqrt{W}$. If values below $0.25 (\sigma_{ys} + \sigma_o) \sqrt{W}$ are anticipated, the displacement V_o should be restricted to correspondingly lower values.

7.4 Loading Procedure - The specimen is loaded until the crack extends or until a pre-selected displacement is reached. During the



loading, autographic records of displacement versus time and of load versus time are obtained. Alternatively, a single record of load versus displacement may be adequate. Specimen displacement measurements, only, are used in the calculations; the wedge load measurement, however, gives supplementary information about the nature of the crack propagation.

7.4.1 To measure K_a or K_{Ia} a segment of unstable crack extension as defined in 8.1.1 must occur. The occurrence of unstable crack extension will normally be apparent to the operator, both audibly and as an abrupt load drop on the test record. The operator should continue the test until loading of the specimen just resumes, and then remove the loading on the wedge to avoid further crack propagation.

7.4.2 If cracking has not occurred by the time a preselected displacement, V_o , has been attained, the load may be released; and an attempt can be made to induce cracking by repeated loading of the specimen. If multiple loading is used, the permanent displacement remaining after the wedge is removed, V_a , must be measured and recorded after each load application. The total accumulated permanent displacement, ΣV_a , is used in calculating K_o and K_a .

7.5 Marking the Arrested Crack - The position of the arrested crack can be marked by heat tinting. For steels, heating at 260-370C for 10-30 minutes has proved successful; for some aluminum alloys heating for 24 hours has proved successful. Any time and temperature combination which clearly marks the arrested crack front is acceptable. The appearance of heat tinting on freshly machined (or ground and sanded) surfaces may provide a clue to the heat tinting progress on the fracture surfaces. If the fracture surfaces are to be examined microscopically, lower heat tinting temperatures are recommended.



An alternative to heat tinting is to extend the crack by fatigue.

7.5.1 After heat tinting, the specimen is broken completely in two. This can usually be done with the wedging apparatus used in testing the specimen. The breaking open of steel specimens may be facilitated by cooling them in dry ice or liquid nitrogen.

7.5.2 Measurement of Arrested Crack Length - Measure the crack length on the heat tinted fracture surface to the nearest 1.0 percent at the following three positions: at the center (mid-thickness) of the specimen, and midway between the center and the bottom of the side groove on each side. The average of these three measurements defines the arrested crack length, a_f .

8.0 Calculations and Interpretation of Results

8.1 Interpretation of Test Record - The displacement, V_o , corresponding to crack initiation, is shown on the test records in Figure 4. The initial displacement, V_o , used in calculating K_o is the sum of V_o' and ΣV_a , the accumulated permanent displacement in previous loading cycles as described in 7.4.3.

8.1.1 The displacement, V_f' , corresponding to crack arrest, is shown on the test record in Figure 4. The final displacement, V_f used in calculating K_f is the sum of V_f' and ΣV_a .

8.1.2 In order to establish a proper value for V_f , it must be verified that unstable cracking occurred. Evidence of the occurrence of unstable cracking is a load drop of at least 10 percent from P_{max} . This should occur in a time interval of less than 100 msec (interval B-C in the load time record, Figure 4a).



8.1.3 The arrest displacement V_f' is the displacement read from the test record at the time corresponding to point C, which is the time at which the wedge load passes through a minimum.

8.2 Calculation of K_o and K_f - Calculate K_o and K_f from the following equation

$$K = (VEf(a/W)/W^{1/2})(B/B_N)^{1/2}$$

where:

$$f(a/w) = \frac{2.24 [1.72 - 0.9 (a/W) + (a/W)^2][1 - (a/W)]^{1/2}}{[9.85 - 0.17 (a/W) + 11.0 (a/W)^2]}$$

where:

V = initial displacement, V_o , or arrest displacement, V_f , as determined in 8.1,

E = Young's modulus, MPa,

a = initial slot length, a_o , or final crack length, a_f , as determined in 7.5.2,

W = specimen depth, mm

B = specimen thickness as shown in Figure 4, mm, and

B_N = specimen width at crack plane as shown in

Figure 4,

To calculate K_o , use $a = a_o$ and $V = V_o$. To calculate K_f , use $a = a_f$ and $V = V_f$.



8.2.1 To facilitate calculation of K_{Ic} and K_{Ic} values of $f(a/W)$, are tabulated below for specific values of a/W . (Linear interpolation between tabled values gives satisfactory results.)

a/W	$f(a/W)$	a/W	$f(a/W)$
0.30	0.268	0.60	0.159
0.35	0.248	0.65	0.143
0.40	0.228	0.70	0.128
0.45	0.210	0.75	0.113
0.50	0.192	0.80	0.098
0.55	0.175	0.85	0.082

8.3 Size Requirements - In order for K_{Ic} to be a valid measure of K_{Ia} or K_{Ic} , the following requirements must be met.

8.3.1 The unbroken ligament, $W - a_f$, shall exceed $0.1W$.

8.3.2 The unbroken ligament, $W - a_f$, shall exceed $(4/\pi)[K_{Ic}/(\sigma_{ys} + \sigma_o)]^2$ where σ_{ys} is the 0.2 percent offset yield strength of the test material (measured by Method E8) at the test temperature, and σ_o is a strain rate correction equal to 205 MPa for steels.

8.4 Plane Strain - In order for K_{Ic} to be a valid measure of K_{Ia} the thickness, B , must exceed $1.25 [K_{Ic}/(\sigma_{ys} + \sigma_o)]^2$.

9.0 Report

9.1 Test identification.

9.1.1 Date.

9.1.2 Specimen number.



- 9.1.3 Crack plane orientation.
- 9.2 Material.
 - 9.2.1 Material type.
 - 9.2.2 Young's modulus.
 - 9.2.3 Yield strength (offset = 0.2%) as determined by Method E8.
- 9.3 Test temperature.
 - 9.3.2 Notch depth.
- 9.4 Specimen dimensions.
 - 9.4.1 Thickness, B.
 - 9.4.2 B_N/B .
 - 9.4.3 Width, W.
- 9.5 Crack length measurements.
 - 9.5.1 At machined notch, a_0 .
 - 9.5.2 At arrest.
 - 9.5.2.2 at 1/4 points.
 - 9.5.2.3 Average crack length at arrest, a_f .
- 9.6 Test record.
 - 9.6.1 Load and displacement records and associated calculations.
 - 9.6.2 Critical displacements.
 - 9.6.2.1 Accumulated permanent displacement in previous loading cycles, if any, ΣV_a .
 - 9.6.2.2 Displacement (on last cycle) corresponding to crack initiation, V_0' .
 - 9.6.2.3 Total displacement corresponding to crack initiation, $V_0 = V_0' + \Sigma V_a$.
 - 9.6.2.4 Displacement (on last cycle) corresponding to crack arrest, V_f' .
 - 9.6.2.5 Total displacement corresponding to crack arrest, $V_f = V_f' + \Sigma V_a$.
 - 9.6.3 Load drop as percent of P_{max} .
- 9.7 Calculated values of crack initiation and crack arrest.



- 9.7.1 K_o and K_a (K_{Ia}).
- 9.8 Validity requirements.
- 9.8.1 Load drop.
- 9.9.2 Uncracked ligament length.

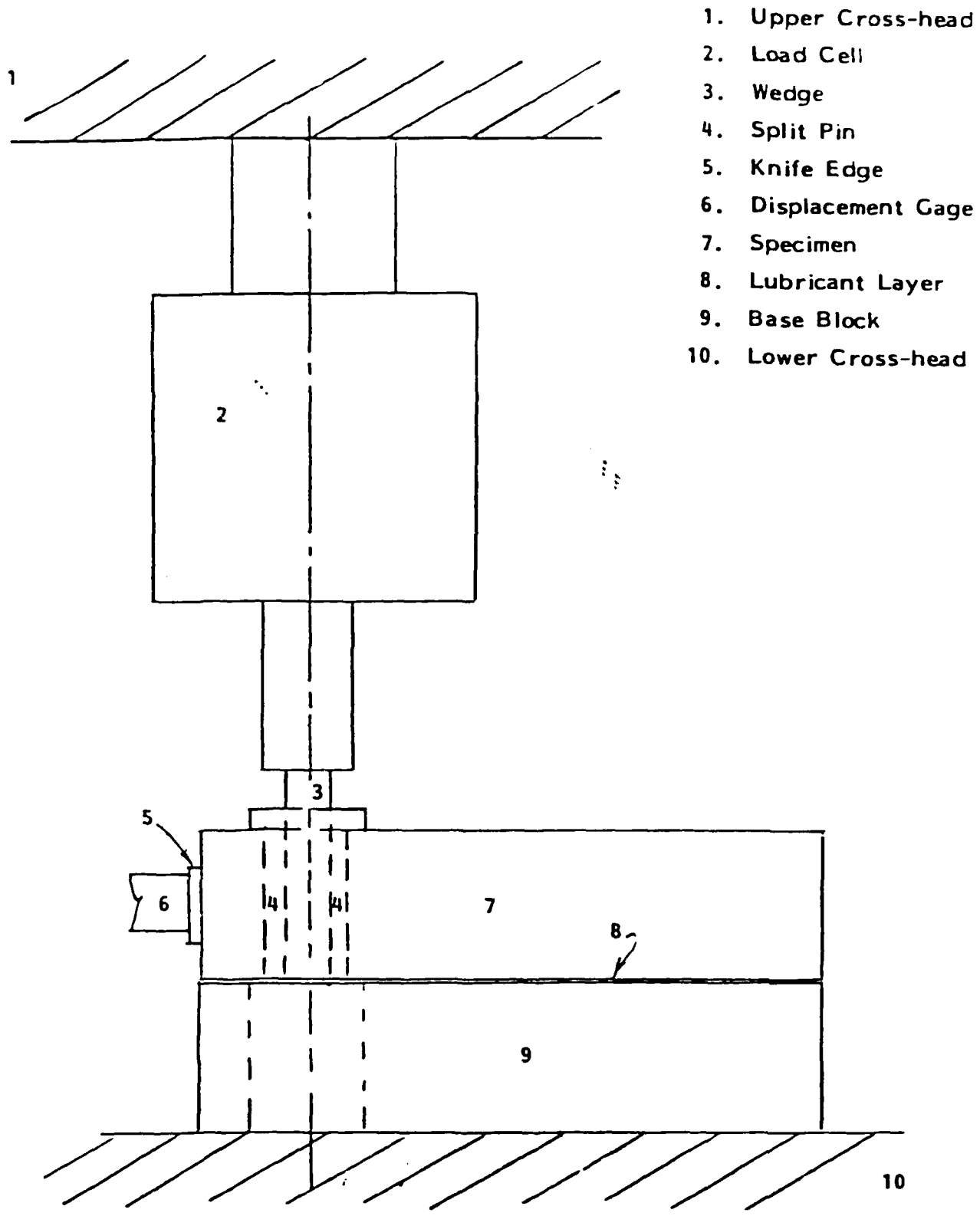
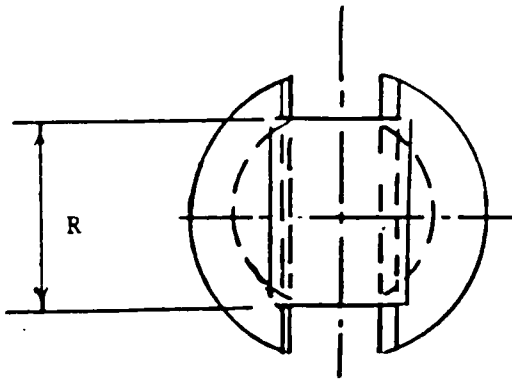

Fig. A2-1 Typical Load Train



Suggested Wedge and Split-Pin Dimensions:

W	D	R	S*
50.8	19	16	16.2
101.6	25.4	21.6	16.2

T depends on plate thickness and test machine requirements

*S may be larger or smaller depending on "T"

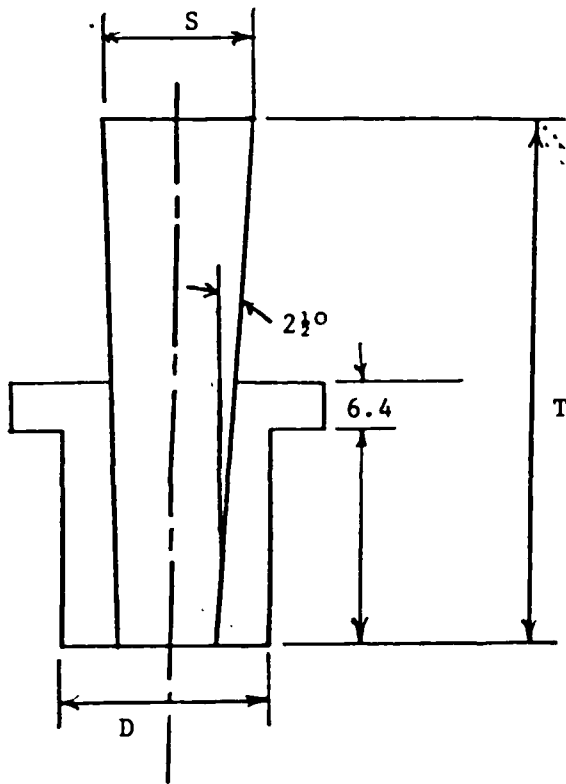
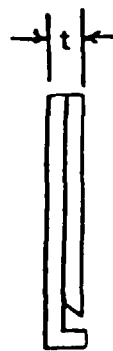
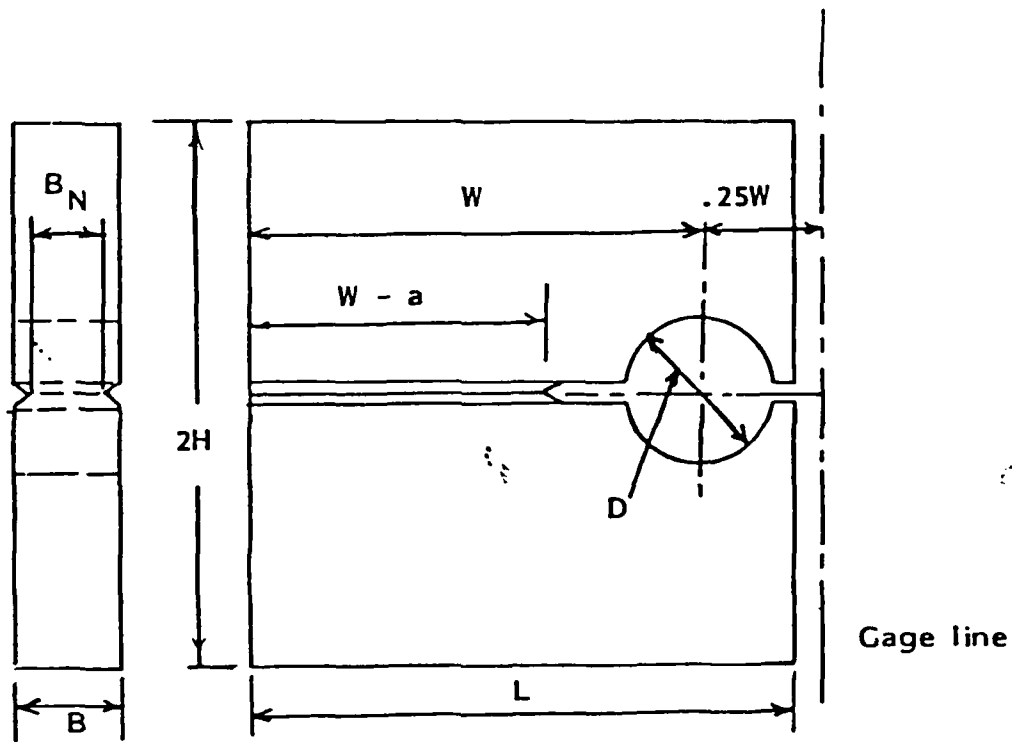

Fig. A2-2 Wedge and split-pin loading assembly, (mm)



Knife edge

W	=	122
W - a	=	80
D	=	25.4 + 1.00 - 0.00
2H	=	153
L	=	150
B_N/B	=	0.75
t	=	3.0

(All dimensions mm)

Fig. A2-3 Dimensions of compact crack arrest (CCA) test specimen.
(Some specimens did not have side-grooves.)

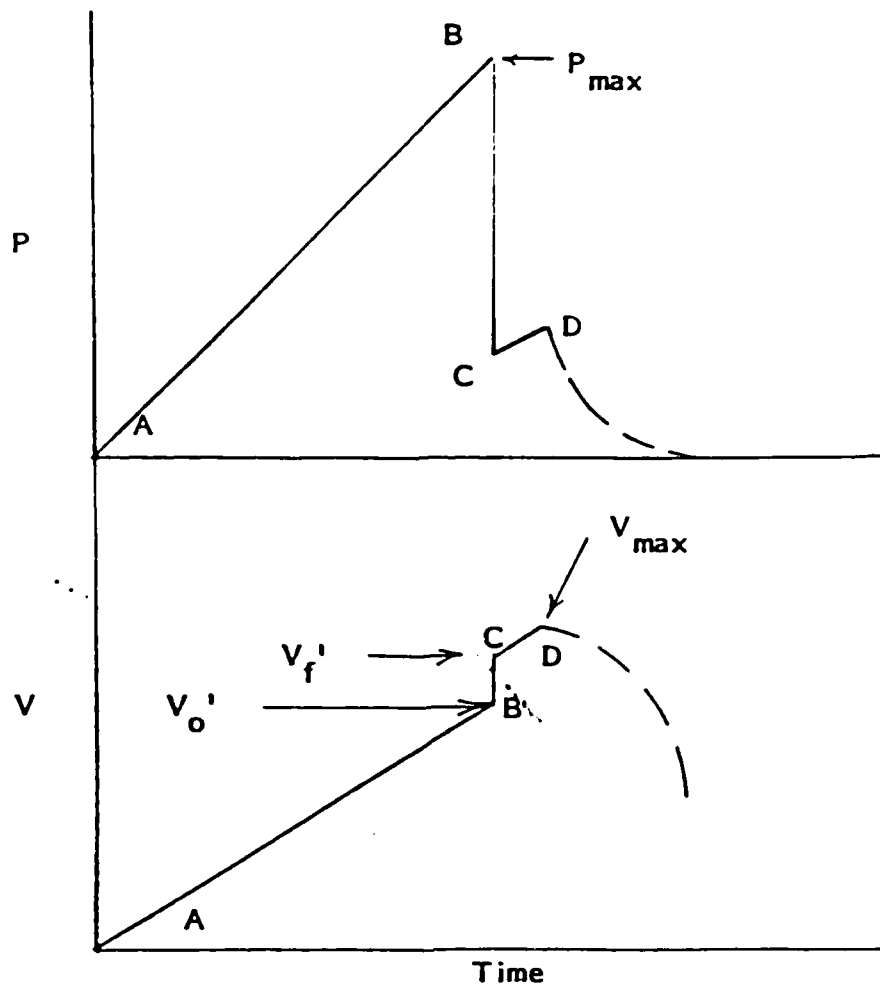

(a)

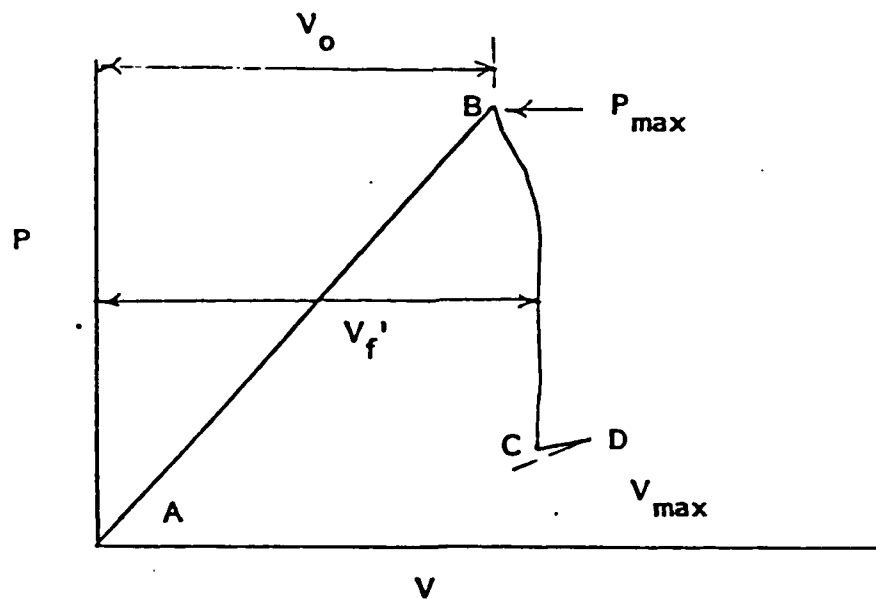

(b)

Fig. A2-4 (a) Typical load and displacement vs. time diagrams.
 (b) Typical load-displacement diagram.

DISTRIBUTION LIST

No. of Copies	To
1	Office of the Under Secretary of Defense for Research and Engineering, The Pentagon, Washington, DC 20301
	Commander, U. S. Army Laboratory Command, 2800 Powder Mill Road, Adelphi, MD 20783-1145
1	ATTN: SLCIS-IM-TL
	Commander, Defense Technical Information Center, Cameron Station, Building 5, 5010 Duke Street, Alexandria, VA 22304-6145
2	ATTN: DTIC-FDAC
1	Metals and Ceramics Information Center, Battelle Columbus Laboratories, 505 King Avenue, Columbus, OH 43201
	Commander, Army Research Office, P. O. Box 12211, Research Triangle Park, NC 27709-2211
1	ATTN: Information Processing Office
	Commander, U.S. Army Materiel Command, 5001 Eisenhower Avenue, Alexandria, VA 22333
1	ATTN: AMCLD
	Commander, U.S. Army Materiel Systems Analysis Activity, Aberdeen Proving Ground, MD 21005
1	ATTN: AMXSJ-MP, H. Cohen
	Commander, U.S. Army Electronics Research and Development Command, Fort Monmouth, NJ 07703
1	ATTN: AMDSD-L
1	AMDSD-E
	Commander, U.S. Army Missile Command, Redstone Scientific Information Center, Redstone Arsenal, AL 35898-5241
1	ATTN: AMSMI-RKP, J. Wright, Bldg. 7574
1	AMSMI-RD-CS-R/ILL Open Lit
1	AMSMI-RLM
	Commander, U.S. Army Armament, Munitions and Chemical Command, Dover, NJ 07801
2	ATTN: Technical Library
1	AMDAR-LCA, Mr. Harry E. Peibly, Jr., PLASTECH, Director
	Commander, U.S. Army Natick Research, Development, and Engineering Center, Natick, MA 01760
1	ATTN: Technical Library
	Commander, U.S. Army Satellite Communications Agency, Fort Monmouth, NJ 07703
1	ATTN: Technical Document Center
	Commander, U.S. Army Tank-Automotive Command, Warren, MI 48090
1	ATTN: AMSTA-ZSK
2	AMSTA-TSL, Technical Library
	Commander, White Sands Missile Range, NM 88002
1	ATTN: STEWS-WS-VT

No. of Copies	To
1	President, Airborne, Electronics and Special Warfare Board, Fort Bragg, NC 28307 ATTN: Library
1	Director, U.S. Army Ballistic Research Laboratory, Aberdeen Proving Ground, MD 21005 ATTN: AMDAR-TSB-S (STINFO)
1	Commander, Dugway Proving Ground, Dugway, UT 84022 ATTN: Technical Library, Technical Information Division
1	Commander, Harry Diamond Laboratories, 2800 Powder Mill Road, Adelphi, MD 20783 ATTN: Technical Information Office
1	Director, Benet Weapons Laboratory, LCWSL, USA AMCCOM, Watervliet, NY 12189 ATTN: AMSMC-LCB-TL
1	AMSMC-LCB-R
1	AMSMC-LCB-RM
1	AMSMC-LCB-RP
1	Commander, U.S. Army Foreign Science and Technology Center, 220 7th Street, N.E., Charlottesville, VA 22901 ATTN: Military Tech
1	Commander, U.S. Army Aeromedical Research Unit, P.O. Box 577, Fort Rucker, AL 36360 ATTN: Technical Library
1	Director, Eustis Directorate, U.S. Army Air Mobility Research and Development Laboratory, Fort Eustis, VA 23604-5577 ATTN: SAVDL-E-MOS (AVSCOM)
1	U.S. Army Aviation Training Library, Fort Rucker, AL 36360 ATTN: Building 5906-5907
1	Commander, U.S. Army Agency for Aviation Safety, Fort Rucker, AL 36362 ATTN: Technical Library
1	Commander, USACDC Air Defense Agency, Fort Bliss, TX 79916 ATTN: Technical Library
1	Commander, U.S. Army Engineer School, Fort Belvoir, VA 22060 ATTN: Library
1	Commander, U.S. Army Engineer Waterways Experiment Station, P. O. Box 631, Vicksburg, MS 39180 ATTN: Research Center Library
1	Technical Director, Human Engineering Laboratories, Aberdeen Proving Ground, MD 21005 ATTN: Technical Reports Office
1	Commandant, U.S. Army Quartermaster School, Fort Lee, VA 23801 ATTN: Quartermaster School Library

No. of
Copies

To

1 Naval Research Laboratory, Washington, DC 20375
1 ATTN: Code 5830
2 Dr. G. R. Yoder - Code 6384

Chief of Naval Research, Arlington, VA 22217
1 ATTN: Code 471

1 Edward J. Morrissey, AFWAL/MLTE, Wright-Patterson Air Force, Base, OH 45433

Commander, U.S. Air Force Wright Aeronautical Laboratories,
Wright-Patterson Air Force Base, OH 45433
1 ATTN: AFWAL/MLC
1 AFWAL/MLLP, M. Forney, Jr.
1 AFWAL/MLBC, Mr. Stanley Schulman

National Aeronautics and Space Administration, Marshall Space Flight Center,
Huntsville, AL 35812
1 ATTN: R. J. Schwinghammer, EH01, Dir, M&P Lab
1 Mr. W. A. Wilson, EH41, Bldg. 4612

U.S. Department of Commerce, National Bureau of Standards, Gaithersburg,
MD 20899
1 ATTN: Stephen M. Hsu, Chief, Ceramics Division, Institute for Materials
Science and Engineering

1 Committee on Marine Structures, Marine Board, National Research Council,
2101 Constitution Ave., N.W., Washington, DC 20418

1 Librarian, Materials Sciences Corporation, Guynedd Plaza 11, Bethlehem Pike,
Spring House, PA 19477

1 The Charles Stark Draper Laboratory, 68 Albany Street, Cambridge, MA 02139

Wyman-Gordon Company, Worcester, MA 01601
1 ATTN: Technical Library

Lockheed-Georgia Company, 86 South Cobb Drive, Marietta, GA 30063
1 ATTN: Materials and Processes Engineering Dept. 71-11, Zone 54

General Dynamics, Convair Aerospace Division, P.O. Box 748, Fort Worth, TX 76101
1 ATTN: Mfg. Engineering Technical Library

1 Mechanical Properties Data Center, Belfour Stulen Inc., 13917 W. Bay Shore Drive,
Traverse City, MI 49684

1 Mr. R. J. Zentner, EAI Corporation, 198 Thomas Johnson Drive, Suite 16,
Frederick, MD 21701

4 Dr. E. J. Ripling, Materials Research Laboratory, One Science Road, Glenwood,
IL 60425

Director, U.S. Army Materials Technology Laboratory, Watertown, MA 02172-0001
2 ATTN: SLCMT-IML
1 SLCMT-IMA-P
1 SLCMT-TMT, Pat Gaw
1 SLCMT-ISC
15 SCLMT-EMM, Mr. J. Cowie

U.S. Army Materials Technology Laboratory,
Watertown, MA 02172-0001
CRACK ARREST FRACTURE TOUGHNESS OF
ARMOR STEELS -
E. J. Ripling
Materials Research Laboratory, Inc.
One Science Road
Glenwood, IL 60425
Technical Report MTL TR 87-56, October 1987
58 pp - illus.-tables, Contract DAAG29-81-D-0100
D/A Project IL161102AH84
Final Report, January 31, 1986 - January 30, 1987

A method for evaluating break-up, or shattering and cracking may be by the use of the crack arrest fracture toughness, K_a . Use of this K_a would not be restricted to steels, but could be applied to other armor materials also. The crack arrest fracture toughness, K_{Ia} , of the two steels were shown to be different, the 4130 being tougher than 4340. The significance of this can only be ascertained by comparing these results with ballistic test data.

AD UNCLASSIFIED
UNLIMITED DISTRIBUTION
Key Words
High strength steels
Armor plate
Transition temperatures

U.S. Army Materials Technology Laboratory,
Watertown, MA 02172-0001
CRACK ARREST FRACTURE TOUGHNESS OF
ARMOR STEELS -
E. J. Ripling
Materials Research Laboratory, Inc.
One Science Road
Glenwood, IL 60425
Technical Report MTL TR 87-56, October 1987
58 pp - illus.-tables, Contract DAAG29-81-D-0100
D/A Project IL161102AH84
Final Report, January 31, 1986 - January 30, 1987

A method for evaluating break-up, or shattering and cracking may be by the use of the crack arrest fracture toughness, K_a . Use of this K_a would not be restricted to steels, but could be applied to other armor materials also. The crack arrest fracture toughness, K_{Ia} , of the two steels were shown to be different, the 4130 being tougher than 4340. The significance of this can only be ascertained by comparing these results with ballistic test data.

U.S. Army Materials Technology Laboratory,
Watertown, MA 02172-0001
CRACK ARREST FRACTURE TOUGHNESS OF
ARMOR STEELS -
E. J. Ripling
Materials Research Laboratory, Inc.
One Science Road
Glenwood, IL 60425
Technical Report MTL TR 87-56, October 1987
58 pp - illus.-tables, Contract DAAG29-81-D-0100
D/A Project IL161102AH84
Final Report, January 31, 1986 - January 30, 1987

A method for evaluating break-up, or shattering and cracking may be by the use of the crack arrest fracture toughness, K_a . Use of this K_a would not be restricted to steels, but could be applied to other armor materials also. The crack arrest fracture toughness, K_{Ia} , of the two steels were shown to be different, the 4130 being tougher than 4340. The significance of this can only be ascertained by comparing these results with ballistic test data.

AD UNCLASSIFIED
UNLIMITED DISTRIBUTION
Key Words
High strength steels
Armor plate
Transition temperatures

U.S. Army Materials Technology Laboratory,
Watertown, MA 02172-0001
CRACK ARREST FRACTURE TOUGHNESS OF
ARMOR STEELS -
E. J. Ripling
Materials Research Laboratory, Inc.
One Science Road
Glenwood, IL 60425
Technical Report MTL TR 87-56, October 1987
58 pp - illus.-tables, Contract DAAG29-81-D-0100
D/A Project IL161102AH84
Final Report, January 31, 1986 - January 30, 1987

A method for evaluating break-up, or shattering and cracking may be by the use of the crack arrest fracture toughness, K_a . Use of this K_a would not be restricted to steels, but could be applied to other armor materials also. The crack arrest fracture toughness, K_{Ia} , of the two steels were shown to be different, the 4130 being tougher than 4340. The significance of this can only be ascertained by comparing these results with ballistic test data.

END

DATE

FILMED

3-88

DTIC