

NO-A107 017

PARAMETRIC DEPENDENCE IN THE EQUILIBRIUM DYNAMICS OF
ROTATING STRUCTURES(U) BOSTON UNIV MA COLL OF
ENGINEERING J BAILLIEUL 01 JUN 87 AFOSR-RR-87-1487

1/1

UNCLASSIFIED

AFOSR-85-0144

F/G 20/11

NL



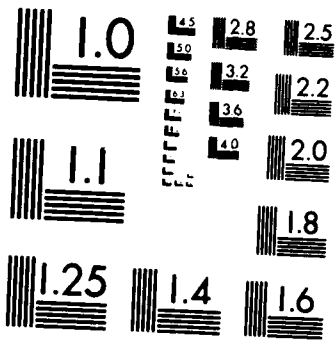

MICROCOPY RESOLUTION TEST CHART
NATIONAL BUREAU OF STANDARDS-1963-A

AD-A187 817

REPORT DOCUMENTATION PAGE

DTIC ELECTE NOV 16 1987 S D 2

1a. REPORT SECURITY CLASSIFICATION UNCLASSIFIED		1b. RESTRICTIVE MARKINGS ESH	
2a. SECURITY CLASSIFICATION AUTHORITY		3. DISTRIBUTION/AVAILABILITY OF REPORT Approved for public release; distribution unlimited.	
2b. DECLASSIFICATION/DOWNGRADING SCHEDULE			
4. PERFORMING ORGANIZATION REPORT NUMBER(S)		5. MONITORING ORGANIZATION REPORT NUMBER(S) AFOSR-TR-87-1487	
6a. NAME OF PERFORMING ORGANIZATION College of Engineering Boston University	6b. OFFICE SYMBOL (If applicable) AE/ME	7a. NAME OF MONITORING ORGANIZATION Air Force Office of Scientific Research	
6c. ADDRESS (City, State and ZIP Code)		7b. ADDRESS (City, State and ZIP Code) Directorate of Mathematical & Information Sciences, Bolling AFB DC 20332-6448 <i>Bolling 410</i>	
8a. NAME OF FUNDING/SPONSORING ORGANIZATION AFOSR	8b. OFFICE SYMBOL (If applicable) NM	9. PROCUREMENT INSTRUMENT IDENTIFICATION NUMBER AFOSR-85-0144	
8c. ADDRESS (City, State and ZIP Code) Bolling AFB DC 20332-6448 <i>Bolling 410</i>		10. SOURCE OF FUNDING NOS.	
		PROGRAM ELEMENT NO. 61102F	PROJECT NO. 2304
		TASK NO. A1	WORK UNIT NO.
11. TITLE (Include Security Classification) Parametric Dependence in the Equilibrium Dynamics of Rotating Structures (unclassified)			
12. PERSONAL AUTHOR(S) Prof. John Baillieul			
13a. TYPE OF REPORT Interim	13b. TIME COVERED FROM 4/15/86 TO 4/14/87	14. DATE OF REPORT (Yr., Mo., Day) 6/1/87	15. PAGE COUNT 10
16. SUPPLEMENTARY NOTATION			
17. COSATI CODES		18. SUBJECT TERMS (Continue on reverse if necessary and identify by block number)	
FIELD	GROUP	Classical mechanics, beam theories, equilibrium dynamics, kinematic chains ←	
	SUB. GR.		
19. ABSTRACT (Continue on reverse if necessary and identify by block number) This report summarizes work done by the author during the past twelve months on the dynamics of complex rotating systems. Our recent work on the mechanics of rotating elastic structures shows a complex dependency of asymptotic equilibrium states on physical parameters such as elasticity of the material and total momentum of the structure. For multiply articulated rigid bodies undergoing large angle rotations, it is shown explicitly how there can be a sensitive dependence of equilibrium states on parameters of inertia and angular momentum. This suggests that recent work on <i>geometrically nonlinear</i> beam theories may be significant not only for transient analysis, but for accurately modeling asymptotic dynamics as well. <i>Key words</i>			
20. DISTRIBUTION/AVAILABILITY OF ABSTRACT UNCLASSIFIED/UNLIMITED <input checked="" type="checkbox"/> SAME AS RPT. <input type="checkbox"/> DTIC USERS <input type="checkbox"/>		21. ABSTRACT SECURITY CLASSIFICATION UNCLASSIFIED	
22a. NAME OF RESPONSIBLE INDIVIDUAL Major James Crowley, Dir. Math and Inf. Sciences		22b. TELEPHONE NUMBER (Include Area Code) (202) 767-	22c. OFFICE SYMBOL NM

PARAMETRIC DEPENDENCE IN THE EQUILIBRIUM
DYNAMICS OF ROTATING STRUCTURES*

by **AFOSR-TR-87-1407**

J. Baillieul
Aerospace/Mechanical Engineering
Boston University
Boston, MA 02215

Abstract

Recent work on the qualitative dynamics of rotating elastic structures is summarized, showing a complex dependency of asymptotic equilibrium states on physical parameters such as elasticity of the material and total momentum of the structure. For multiply articulated rigid bodies undergoing large angle rotations, it may also be shown explicitly how there can be a sensitive dependence of equilibrium states on parameters of inertia and angular momentum. This suggests that recent work on *geometrically nonlinear* beam theories may be significant not only for transient analysis, but for accurately modeling asymptotic dynamics as well.

1. INTRODUCTION

Several interesting results have been reported in the recent literature dealing with the nonlinear mechanics of rotating elastic structures. Baillieul and Levi (1987) have given a detailed description (by means of a geometric Lagrangian formulation of the basic governing equations) of the asymptotic equilibrium behavior of several prototypical structures. For one such structure, consisting of a rigid body with a simple (Bernoulli-Euler) elastic beam attached, it has been shown how the transient dynamics involve an interplay between inertial forces due to rotation and viscoelastic damping of vibrations of the beam. More specifically, it has been shown that in the absence of external forcing, the damping will have a dominant influence on the long term dynamics, and ultimately all movement of the appendage with respect to the rigid body coordinate frame will disappear. Moreover, in asymptotic steady state, rotations always tend to a constant angular velocity, and this velocity vector is aligned with a principal axis of the steady state inertia tensor of the body-beam complex.

With a slightly different focus, Simo and Vu-Quoc (1987) have shown that in modeling the dynamics of

* The author gratefully acknowledges support from the Air Force Office of Scientific Research under Grant No. AFOSR 85-0144



or

on
n/

ty Codes
and/or
ial

A-1		
-----	--	--

rotating beams one requires the use of *geometrically nonlinear* beam theories to adequately account for the influence of centrifugal forces on bending stiffness. The essential feature in these theories is their incorporation of higher order strain energies. While the geometric formalism and the simple beam model used by Baillieul and Levi (1987) incorporates many of the effects of inertial forces, it does not capture the phenomenon of increased bending stiffness, and this suggests that such a model must be refined to provide a faithful representation of transient behavior during rapid, large-angle slewing of the beam. The extent to which more complex continuum mechanical models are also required for asymptotic stability analysis is the subject of current research.

In Section 2 of this report, we summarize our recent work on the asymptotic equilibrium dynamics of a rotating structure consisting of a rigid body with a simple elastic beam attached. A more detailed account is given in Section 3 of the equilibrium dynamics of a kinematic chain being rotated about an axis aligned with the force of gravity. In this case a detailed account of the dependence of the equilibria on the various mechanical parameters points to a high degree of complexity that must be accounted for in any theory of the mechanics of rotating structures having elastic and articulated components.

2. EQUILIBRIA IN ROTATING STRUCTURES

In Baillieul and Levi (1987) a general theory of rotational mechanics is applied to a detailed study of the stability and equilibrium dynamics of a structure consisting of a rigid body with a cantilevered beam attachment.

This structure is depicted in Figure 2.1

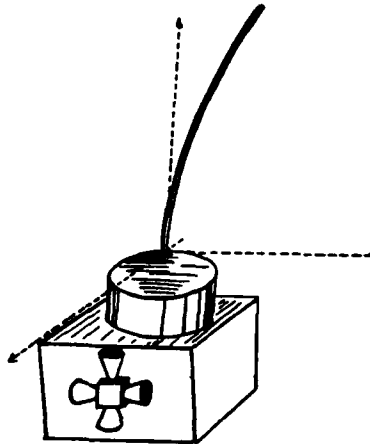

Figure 2.1: A rigid body with cantilevered beam attachment.

Following the general modeling procedure outlined in this reference, we affix a 'body coordinate frame' so that the origin coincides with the point of attachment of the beam, and the z_3 -axis is aligned with the axis of the undeflected beam. Elastic deformations of the beam are described in terms of a function $u(z, t)$ which specifies the position at time t of a particle whose neutral (or undeflected) position is $(0, 0, z)$ in the chosen

body coordinate system.

To form a complete model of the dynamics of this structure, we must describe the time evolution of the body coordinate system with respect to a fixed inertial frame together with motions of $u(z, t)$ with respect to the body system. The position and orientation of the body frame with respect to the inertial frame is described at each time t by a pair $Y(t) \in SO(3)$ (giving the orientation) and $y(t) \in \mathbb{R}^3$ (locating the origin of the body frame with respect to the inertial frame). If the position of a point is prescribed by a vector u in the body frame and by a vector U in the inertial frame, then u and U are related by $U = Y(t)u + y(t)$. The corresponding velocities are given by

$$U_t = Y(\Omega u + u_t) + \dot{y}$$

where $\Omega(t)$ is the skew-symmetric matrix

$$\Omega = \begin{pmatrix} 0 & -\omega_3 & \omega_2 \\ \omega_3 & 0 & -\omega_1 \\ -\omega_2 & \omega_1 & 0 \end{pmatrix}$$

of angular velocities about the corresponding body axes.

With these notational conventions, we may prescribe the kinetic energy by

$$T = \frac{1}{2} \omega^T I \omega + m_b \dot{y}^T Y \Omega \bar{c} + \frac{1}{2} m_b \|\dot{y}\|^2 + \frac{1}{2} \int_0^\ell \|Y(\Omega u + u_t) + \dot{y}\|^2 dz.$$

Here $\omega = (\omega_1, \omega_2, \omega_3)^T$ is a vector whose entries are the above angular velocities, \bar{c} is the center of mass of the rigid body in the body frame, m_b is the mass of the rigid body, we have scaled the linear mass density of the beam to be one, and the inertia tensor with respect to the body frame is given by

$$I = \begin{pmatrix} I_x & I_{xy} & I_{xz} \\ I_{xy} & I_y & I_{yx} \\ I_{xz} & I_{yx} & I_z \end{pmatrix},$$

where I_x is the moment of inertia with respect to the x -axis ($= z_1$ -axis), etc. Since the beam is clamped at the origin of the (z_1, z_2, z_3) -coordinate system and free at its other end, the following boundary conditions are assumed:

$$u_i(0, t) = \frac{\partial u_i}{\partial z}(0, t) = \frac{\partial^2 u_i}{\partial z^2}(l, t) = \frac{\partial^3 u_i}{\partial z^3}(l, t) = 0, \quad i = 1, 2.$$

and $u_3(0, t) = \frac{\partial u_3}{\partial z}(\ell, t) = 0$. These boundary conditions are standard in the theory of clamped-free beams. Here u_1, u_2, u_3 are the deflections: $u = (u_1, u_2, z + u_3)$. Note that u_3 is *not* the z -coordinate of u .

The equations of motion for our rotating structure are obtained by means of a geometric formalism, the details of which appear in Baillieul and Levi (1987). Thus we look for extremals of the Lagrangian $L = T - V$ where T is the kinetic energy given above and potential V is an appropriately chosen measure of *strain energy*. In the analysis detailed below, we focus on the very simple strain energy

$$V(u) = \frac{1}{2} \int_0^\ell [\mu_1(u_1'')^2 + \mu_2(u_2'')^2 + \mu_3(u_3')^2] dz, \quad ' = \frac{\partial}{\partial z},$$

where only quadratic terms were retained and the material is assumed to obey a linear Hooke's law. Here μ_1 (respectively μ_2) gives the bending elasticity within the zz -plane (yz -plane respectively), and μ_3 is the Hooke's constant giving the beam's stretching elasticity. We believe the asymptotic analysis based on this expression gives a physically realistic picture, but Simo and Vu-Quoc (1987) have pointed out that certain important features of the nonlinear dynamics are not captured by so simple a model.

Viscous damping is modeled along classical lines suggested by Kelvin and Voigt by introducing the dissipation function

$$D = D(u, \dot{u}) = \frac{1}{2} \int_0^\ell [k_1(\dot{u}_1'')^2 + k_2(\dot{u}_2'')^2 + k_3(\dot{u}_3')^2] dz, \quad \dot{} = \frac{\partial}{\partial t}, \quad ' = \frac{\partial}{\partial z}, \quad (2.1)$$

where \dot{u}_1'', \dot{u}_2'' can be thought of as the rates of change of appropriate curvatures, while \dot{u}_3' is the rate of change of the contraction coefficient u_3' . The k_i 's are positive constants reflecting the rates of energy dissipation due to deformation of material in the beam.

The following theorem is proved in Baillieul and Levi (1987) using a geometric theory of Lagrangian mechanics with damping.

Theorem 2.1. *Given the system depicted in Figure 2.1 and with the kinetic energy, potential energy, and dissipation functions described above, the equations of motion are given by*

$$Da + (\mathbf{m}_b \bar{c} + \int_0^\ell \mathbf{u}) \times Y^{-1} \bar{\mathbf{y}} = 0 \quad (2.2)$$

$$D^2 \mathbf{u} + \mu \partial \mathbf{u} + k \bar{c} \cdot Y^{-1} \bar{\mathbf{y}} = 0 \quad (2.3)$$

$$\mathbf{m}_b (\mathbf{y} + Y \bar{c}) - \int_0^\ell Y D^2 \mathbf{u} dz = 0 \quad (2.4)$$

where the quantities in these equations are given as follows. $D(\cdot) = \frac{d}{dt}(\cdot) + \omega \times (\cdot)$, $a(t) = I\omega(t) + \int_0^l u \times (Du)dz$, I is the inertia tensor in the body frame defined above, m_b is the mass of the rigid body component, $\dot{Y} = Y\Omega$, and ∂ is the differential operator defined by $\partial = (\partial_z^4, \partial_z^4, -\partial_z^2)$, $\mu = \text{diag}(\mu_1, \mu_2, \mu_3)$ and $k = \text{diag}(k_1, k_2, k_3)$.

For finite dimensional dissipative mechanical systems, LaSalle's invariance principle can be used to show that states asymptotically approach a minimal invariant subset of the zero set of the dissipation function. To some extent this type of analysis may be carried out for dynamical models of the form (2.2)-(2.4) as illustrated by the following two theorems.

Theorem 2.2: *Solutions of (2.2)-(2.4) which are asymptotic equilibria (i.e. solutions which also satisfy $D = 0$ with D as defined in (2.1)) have the following properties:*

- (i) *there is no dependence on the time variable t in the beam function: $u(z, t) = u_\infty(z)$;*
- (ii) *the angular velocity ω is a constant ω_∞ ;*
- (iii) *the equilibrium angular momentum is a constant. $a_\infty = J_\infty \omega_\infty$, with the equilibrium inertia tensor of the combined body-beam system given by*

$$J_\infty = I + \int_0^l u^T u E - u u^T dz - m(C_m^T C_m E - C_m C_m^T) \quad (2.5)$$

where $E =$ the identity matrix and $C_m = \frac{1}{m} (m_b \bar{c} + \int_0^l u dz)$ is the center of mass of the body-beam system (expressed in the body frame).

- (iv) *equilibrium rotations are aligned with a principal axis of the equilibrium inertia tensor. and thus*

$$J_\infty \omega_\infty = \lambda \omega_\infty \quad (2.6)$$

Theorem 2.3: *The asymptotic equilibrium beam function $u_\infty(\cdot)$ and the asymptotic equilibrium angular velocity ω_∞ are related by equations (2.5), (2.6) together with the fourth order system of ordinary differential equations*

$$\mu \partial u = -\Omega_\infty^2 (u - C_m), \quad (2.7)$$

where C_m is the center of mass of the body-beam system in the body frame, $u = (u_1, u_2, u_3 + z)$, and Ω_∞ is the skew symmetric matrix whose entries correspond in the appropriate way to the entries in ω_∞ . and where the boundary conditions are as prescribed above.

(2.7) prescribes a nonlinear boundary value problem since Ω_∞ depends on $u_\infty(\cdot)$ through equations (2.5) and (2.6). Some idea of the complexity involved in explicitly determining $u_\infty(\cdot)$ may be gleaned from our analysis of the rotating chain system in the following section.

3. CLASSIFICATION OF EQUILIBRIA IN A ROTATING CHAIN

While a primary goal of much of the work reported in the recent literature on the rotational dynamics has dealt with stability issues for systems undergoing three degree-of-freedom rotations in space, valuable insight may also be gained from selected restricted problems involving single degree-of-freedom rotations. One such problem involves the rotating simple kinematic chain depicted in Figure 3.1. Here a certain number, n , of links of various lengths are connected to form a single-strand planar kinematic chain. We suppose this chain is suspended in such a way that the force of gravity tends to extend the chain to its maximum total length. We further assume there is free rotation (with no actuation or friction) about all joints in the planar chain, but that torque may be applied about the vertical axis (which passes through all links when the linkage is in the fully extended configuration). An alternative description can be given in terms of the Denavit-Hartenberg (1955) parameters:

$$(\alpha_1, a_1, d_1) = \left(\frac{\pi}{2}, 0, 0\right)$$

$$(\alpha_i, a_i, d_i) = (0, l_i, 0), \quad i = 2, \dots, n+1.$$

There is free rotation about the axes z_1, \dots, z_n depicted in Figure 3.1, and an angular rate ω about the z_0 axis can be prescribed. We suppose the links are massless, but each joint in the planar chain has mass m_{i-1} ($i = 2, \dots, n$), and there is a mass m_n located at the tip of the final link. The angles ψ_i depicted in Figure 3.1 measure deviation of each link from its neutral vertical position. We also let ψ_0 denote the angle of rotation of the mechanism about the vertical axis z_0 . (ψ_0 is measured with respect to an arbitrarily chosen reference.)

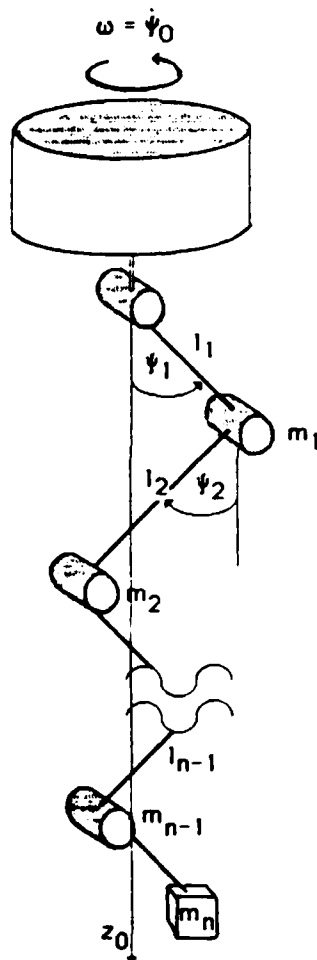

Figure 3.1: An n -degree of freedom planar kinematic chain in a gravitational field rotated about its neutral axis

Following a geometric formalism along lines similar to those detailed in Baillieul and Levi (1987) it is straightforward to write down the dynamical equations of this rotating chain. At present, however, we are simply interested in the special case where $\dot{\psi}_0 = \omega$ (a constant) and $\dot{\psi}_j = 0$ for $j = 1, \dots, n$. Such equilibrium solutions to the dynamical equations are also given as the zeros of the gradient system

$$\frac{\partial L}{\partial \psi} = 0$$

where

$$\begin{aligned} L &= L(\omega; \psi_1, \dots, \psi_n) \\ &= -\frac{1}{2} [m_1(\ell_1 \sin \psi_1)^2 + m_2(\ell_1 \sin \psi_1 + \ell_2 \sin \psi_2)^2 + \dots + m_n(\ell_1 \sin \psi_1 + \dots + \ell_n \sin \psi_n)^2] \omega^2 \\ &\quad - [m_1 \ell_1 \cos \psi_1 + m_2(\ell_1 \cos \psi_1 + \ell_2 \cos \psi_2) + \dots + m_n(\ell_1 \cos \psi_1 + \dots + \ell_n \cos \psi_n)] g \end{aligned}$$

with g designating acceleration due to gravity. This system of equations may be explicitly written out

$$\begin{aligned} &[(m_1 + \dots + m_n)\ell_1 s_1 + (m_2 + \dots + m_n)\ell_2 s_2 + \dots + m_n \ell_n s_n] c_1 \omega^2 \\ &\quad - (m_1 + \dots + m_n) s_1 g = 0 \end{aligned}$$

$$\begin{aligned} &[(m_2 + \dots + m_n)\ell_1 s_1 + (m_2 + \dots + m_n)\ell_2 s_2 + \dots + m_n \ell_n s_n] c_2 \omega^2 \\ &\quad - (m_2 + \dots + m_n) s_2 g = 0 \end{aligned}$$

...

$$[m_n \ell_1 s_1 + m_n \ell_2 s_2 + \dots + m_n \ell_n s_n] c_n \omega^2 - m_n s_n g = 0. \quad (3.1)$$

where, as usual, $s_i = \sin \psi_i$ and $c_i = \cos \psi_i$.

Before showing how the bifurcations and stability characteristics of solutions to (3.1) depend on various parameters in the special case that $n = 2$, we present some general results to the effect that the number of distinct solutions (for arbitrary n) is not less than 2^n and not greater than 4^n , with the exact number of solutions depending on the values of the parameters ℓ_i , m_i , and ω .

Theorem 3.1: For small values of $|\omega|$, there are precisely 2^n distinct solutions to the system (3.1). These solutions are given explicitly by $\{(\psi_1, \dots, \psi_n) : \psi_i = 0 \text{ or } \pi\}$. The index (= number of negative eigenvalues of the Hessian $(\frac{\partial^2 L}{\partial \psi_i^2})$) of any such solution is the number of vector entries, ψ_j , which are equal to π .

This theorem is proved in Baillieul (1987). Physical intuition suggests that there will be more than 2^n equilibrium solutions as the parameter ω is increased in (3.1). To count the total possible number of these solutions, we transform (3.1) into a systems of algebraic (polynomial) equations by means of the trigonometric substitutions $x_i = \cos \psi_i$, $y_i = \sin \psi_i$. The resulting equations together with the auxiliary relations $x_i^2 + y_i^2 - 1 = 0$ ($i = 1, \dots, n$) define a system of $2n$ quadratic hypersurfaces in C^n . We have the following Bezout-type theorem regarding these algebraic equilibrium equations.

Theorem 3.2: For generic choice of parameters $m_1, \dots, m_n; \ell_1, \dots, \ell_n; \omega$ there are 4^n (some possibly complex) solutions to the algebraic equilibrium equations.

Again, this theorem is proved in Baillieul (1987). Because there is a one-to-one correspondence between solutions to (3.1) and real solutions to the corresponding algebraic equilibrium equations. Theorems 3.1 and 3.2 taken together imply the result announced above that

Corollary: Given any values of the parameters $m_1, \dots, m_n; \ell_1, \dots, \ell_n; \omega$, there are at least 2^n but no more than 4^n solutions to the system (3.1).

A precise description of the way in which the numbers and stability characteristics of solutions to (3.1) depend on the parameters in the problem will be given in the case $n = 2$. It is convenient to reformulate the equations by letting $\ell = \ell_1$, $\ell_2 = r\ell$, and $\alpha = m_2/(m_1 + m_2)$. If we moreover assume g has been normalized to be 1, we obtain from (3.1)

$$\begin{aligned} (\ell \sin \psi_1 + \alpha r \ell \sin \psi_2) \cos \psi_1 \omega^2 - \sin \psi_1 &= 0 \\ (\ell \sin \psi_1 + r \ell \sin \psi_2) \cos \psi_2 \omega^2 - \sin \psi_2 &= 0. \end{aligned} \tag{3.2}$$

The following theorem gives a substantial answer to the question of parametric dependence.

Theorem 3.3: Let α and r be fixed in the system of equations (3.2), and suppose $r > 1$.

When $\alpha r > 1$, there is a monotonically increasing dependence of the number of solutions to (3.2) on the parameter $|\omega|$, and as $|\omega|$ increases from 0 to ∞ there are (counting multiplicities) 4, 6, 8, 10, or 12 solutions.

When $\alpha r \leq 1$, there are (counting multiplicities) 4, 6, 8, 10, 12 or 16 solutions to (3.2). In this case, however, there will not in general be a monotone dependence of the number of solutions on the value of $|\omega|$.

Figure 3.2 depicts the parametric dependence of solutions to (3.2) on the parameters α and $|\omega|$ when $r = 1.5$; ℓ has been normalized to be 1.

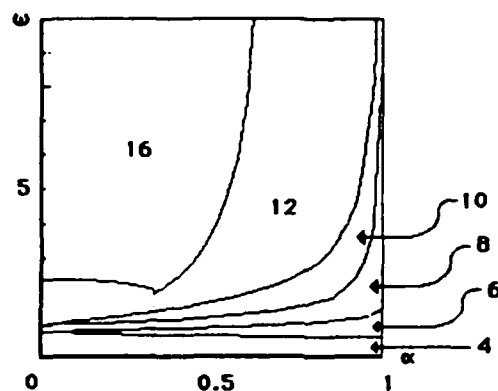

Figure 3.2: Bifurcation locus of equations (3.2) in the case $r = 1.5$. The top curve is cusped at approx $\alpha = 0.33$.

The tables in figure 3.3 show the number of solutions to (3.2) with each possible index of the Hessian of L . These indices of course give the dimension of the unstable manifold associated with each equilibrium.

i	c_1	c_2	c_3	c_4	c_5
0	1	2	2	2	2
1	2	3	4	5	6
2	1	1	2	3	4
total	4	6	8	10	12

Figure 3.3(a): When $\alpha r > 1$ the number of critical points of L (= solutions to (3.2)) increases with $|\omega|$ from 4 to 12. The table gives the number of critical points of each index.

i	c_1	c_2	c_3	c_4	c_5	c_6
0	1	2	2	2	2	4
1	2	3	4	5	6	8
2	1	1	2	3	4	4
total	4	6	8	10	12	16

Figure 3.3(b): When $\alpha r \leq 1$ the number of critical points of L also depends on $|\omega|$. This is no longer a monotonic dependence, however, as indicated by the cusped bifurcation locus illustrated in Fig. 2. The table gives the number of critical points of each index corresponding to each possible number of solutions to (3.2).

4. CONCLUSION

A detailed account has been given of the way in which the equilibria in a rotating kinematic chain depend on a set of parameters (which are easily related to the physical parameters of momentum and inertia in each link in the chain). The intricacy of these results points to a corresponding degree of complexity that may be expected in the equilibrium dynamics of rotating structures where elasticity or fluid dynamics must also be accounted for. For rotating elastic structures, we may ask whether the higher order strain energies of the form advocated by Simo and Vu-Quoc (1987) will lead to equilibrium dynamics which differ qualitatively from the rotating linear beam models studied by Baillieul and Levi (1987).

Near term research goals include extension of this type of equilibrium analysis to articulated structures in a zero gravity environment. Also, dynamic simulations and empirical studies will be carried out to obtain a more detailed understanding of stable equilibria.

REFERENCES

1. Baillieul, J. (1987) "The Equilibrium Dynamics of a Simple Rotating Kinematic Chain," to appear in Proc. of Henniker Conf. Qualitative Methods for the Analysis of Nonlinear Dynamics, SIAM.
2. Baillieul, J., and Levi, M. (1987) "Rotational Elastic Dynamics," *PHYSICA D*, June.
3. Denavit, J., and Hartenberg, R.S. (1955) "A Kinematic Notation for Lower-Pair Mechanisms Based on Matrices," *Trans. ASME: J. of App. Mech., Series E*, June.
4. Simo, J., and Vu-Quoc, L. (1987) "The Role of Nonlinear Theories in Transient Dynamic Analysis of Flexible Structures," to appear *J. of Sound and Vibration*.

END

FILMED

MARCH, 19 88

DTIC