

AD-A100 001

DEPOSITION OF DEVICE QUALITY EPITAXIAL LAYERS OF
GALLIUM NITRIDE AND INDI. (U) ILLINOIS UNIV AT URBANA
COORDINATED SCIENCE LAB 09 OCT 87 TR-2

1/1

UNCLASSIFIED

NO0014-86-K-0274

F/G 7/2

ML



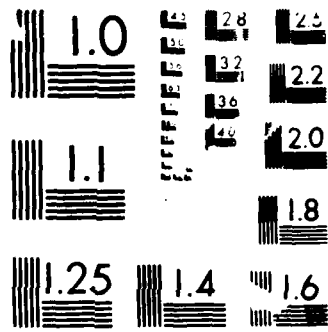

MICROCOPY RESOLUTION TEST CHART
1010A

AD-A188 001

ANNUAL LETTER REPORT

Number: 2
Date: 10/9/87
Period: 5/21/86-10/1/87

CONTRACT

TITLE: Deposition of Device Quality Epitaxial Layers of Gallium Nitride and Indium Nitride for Electronic Applications

NUMBER: N00014-86-K-0274

CONTRACTOR: University of Illinois
Coordinated Science Laboratory
1101 West Springfield Avenue
Urbana, Illinois 61801-3082

DTIC
ELECTE
DEC 02 1987
S H D

CONTRACT PERIOD:
May 21, 1986 to May 20, 1989

PROGRESS:

Project Schedule Relative to Proposed Schedule

The contract authorized the program to begin on May 21, 1986. However, as described in our Semi-Annual Progress Report (dated 4/15/87), major activity on the program did not begin until October 1986 with the arrival of graduate student Rick Powell. Thus this report describes essentially the first year's activities.

The major activity scheduled for the first year of the program was the design and construction of a suitable ultra-high vacuum deposition apparatus and the initiation of shakedown experiments. The apparatus has essentially been completed and shakedown experiments are beginning. The apparatus design and the experimental plan for the shakedown experiments are described in this report.

Project Expenditures

The budget for the first year of the research program was \$149,701. The total funds spent or obligated as of 30 August 1987 were \$113,656. Thus the project spending is consistent with the progress that has been made.

Design of the Deposition Chamber

The overall design of the experimental apparatus was described in the Semi-Annual Progress Report. An essential feature of the design is the use of an extensively equipped analytical chamber, which is shared between the ONR project and a DOE project that is investigating the surface chemistry associated with the deposition of $CuInSe_2$. This configuration will enhance the substrate analysis capabilities that will be available for the ONR apparatus by

DISTRIBUTION STATEMENT A
Approved for public release:
Distribution Unlimited

providing *in situ* ESCA, and possibly ion scattering spectroscopy, as well as the originally planned Auger electron spectroscopy.

A 1/16 scale drawing of the overall apparatus is shown in Fig. 1. The deposition chamber for the ONR project is shown at the right. A similar chamber, which will be used for the DOE project, is shown at the left. The apparatus is designed to accommodate 1 cm x 1 cm substrates. The substrates are introduced through a load lock, shown at the center of the figure. The load lock is evacuated by a 50 l/sec turbomolecular pump and has provisions for substrate bake-out. The substrate insertion arm is then used to move the substrates into a transfer chamber, where they can be picked up by a second manipulation arm and transferred to the substrate holder in the deposition chamber. After deposition the substrates can be passed back through the transfer chamber and into the analytical chamber. Figure 2 shows a photograph of the system.

The ONR deposition chamber is designed to facilitate three types of experiments selected to promote the deposition of stoichiometric GaN and InN.

- 1) Ion-assisted deposition where a modest energy (< 200 eV) nitrogen ion beam will be used in combination with an evaporated flux of Ga or In to increase the nitrogen incorporation probability during film growth.
- 2) A remote plasma-assisted deposition method where N_2 or NH_3 , which is dissociated in a dc hollow cathode, rf or microwave discharge, will be directed onto the substrate surface in combination with an evaporated flux of Ga or In. The apparatus is designed so that this approach can be used in an atomic-layer epitaxy mode.
- 3) A remote gas phase plasma-assisted deposition method where, for example, a dissociated flux of N_2 or NH_3 , produced by a dc hollow cathode, rf or microwave discharge, interacts with a $Ga(CH_3)_3$ which is introduced in the gas phase as indicated schematically in Fig. 3. This approach, which involves reactions in the gas phase as well as at the substrate, is based on the basic instability of the $Ga(CH_3)_3$ molecule.

The internal arrangement of the ONR deposition chamber is shown schematically in Fig. 4. The chamber can be seen at the left side of the photograph shown in Fig. 2. The chamber is 25 cm in diameter by 48 cm long. Pumping is provided by a 500 l/sec Balzers turbomolecular pump, which can be seen in the photograph at the top of the chamber. The overall design of the chamber is similar to that used in an MBE system. Thus the chamber contains about 14,000 l/sec of liquid nitrogen cryopumping for water vapor, as indicated schematically in Fig. 4. The chamber also contains a port for mounting a roots blower pumping system for use with the gas phase remote plasma studies described under item (3) above. However, this pumping system has not been installed at the present time.

The source flange which mounts effusion cells for the Ga and In evaporation, a nitrogen ion beam or plasma source, and a port for a modulated beam mass spectrometer, can be seen on the lower front of the chamber in the photograph. The effusion cells are of the Radak II type with a capacity of 10 gms. Mechanical choppers are suitably placed so that the evaporated beams can be modulated to facilitate characterization studies and the use of deposition methods such as atomic layer epitaxy. Quartz crystal rate monitors are suitably placed to monitor the flux from each of the evaporation sources, as indicated in Fig. 4.

The chamber is equipped with a Eiko Engineering reflection electron diffraction system. The RHEED camera can be seen in the photograph just above the source flange.

The substrate holder is designed to permit rotation in support of the RHEED studies. In the initial configuration substrate heating will be provided by two 200W quartz heating lamps. More heating capacity will be added later, if required, in order to permit substrate temperatures of up to about 1000°C to be obtained. The substrate holder mounting flange also contains the Ga(CH₃)₃ injection ports for the gas phase remote plasma assisted deposition studies. Chamber ports are also available to permit optical spectroscopy measurements in the gas phase region above the substrates.

The analytical section, which can be seen at the rear of the photograph, consists of a custom built vacuum chamber mounted on a Perkin-Elmer Series 1000 ultra-high vacuum system. Specifications for the purchase of an Auger - ESCA electron spectroscopy system, which would be attached to one of the 20 cm flanges on the chamber, have been submitted to the University procurement process. Our future plans call for adding an ion gun to facilitate Auger and ESCA depth profiling and an ion scattering spectroscopy system to provide an independent surface composition measurement capability.

Status of Experimental Program

The initial shakedown experiments will use the ion beam assisted deposition method. The method will be applied to both GaN and InN so that the performance of both evaporation sources can be evaluated.

The ion source is a 3 cm Kaufman type manufactured by Commonwealth Scientific. Since the ion flux is expected to have a high incorporation probability, any impurities in the N₂ working gas delivered to the ion source are expected to have a much greater effect on the purity of the semiconductor films than would residual gases in the deposition chamber. A simple calculation shows that outgassing from the walls of the gas feed system is a potentially serious problem. Thus considerable attention was given to the design of the gas feed system which is shown schematically in Fig. 5. The essential feature of the system is that it is of minimal length and permits gas gettering and high temperature baking in the section between the flow meter and the ion gun.

Experiments are just beginning to evaluate the performance of the ion gun in the low ion energy (single grid) configuration. A multigrid electrostatic energy analyzer has been designed and constructed and is being mounted on the substrate holder. This unit will be used to determine the ion flux and energy that can be obtained under various operating conditions for the gun. A moveable Faraday cup has also been designed for measuring the ion beam profile. The energy range of interest is from about 50 to 200 eV.

Following completion of the ion beam calibration experiments, the performance of the evaporation sources will be evaluated and the rate monitors will be calibrated. Initially aluminum oxide crucibles will be used for both the Ga and In evaporation sources. The same procedures will be followed that are used in GaAs molecular beam epitaxy, including, if necessary the use of boron nitride crucibles. An aluminum oxide crucible will be used for the In evaporation source. We expect the ion beam shakedown tests to be completed by the end of November and the evaporation source shakedown tests to be completed by the end of December. Serious attempts at depositing epitaxial layers will begin the first of January with GaN deposition using aluminum oxide substrates with a (0112) orientation supplied by Insaco of Quakertown, PA. This substrate configuration was selected because it provides a reasonable lattice match to

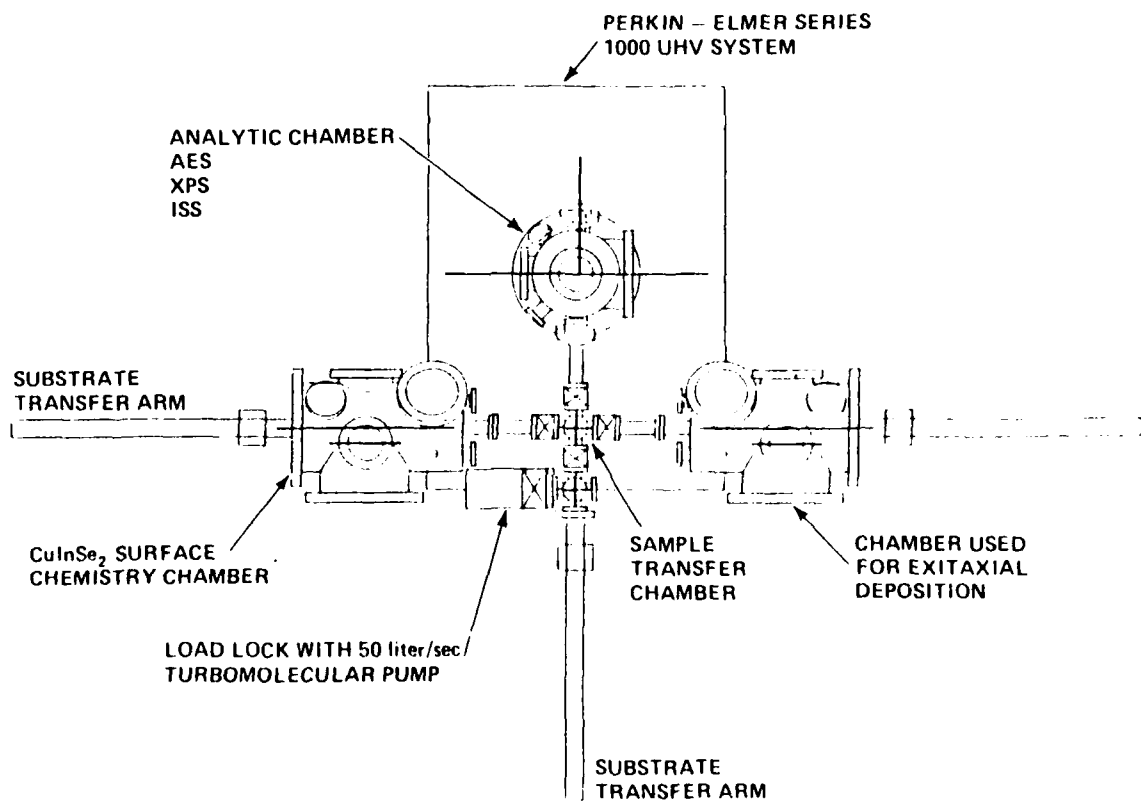

Fig. 1. Plan view of overall apparatus (1/20 scale).

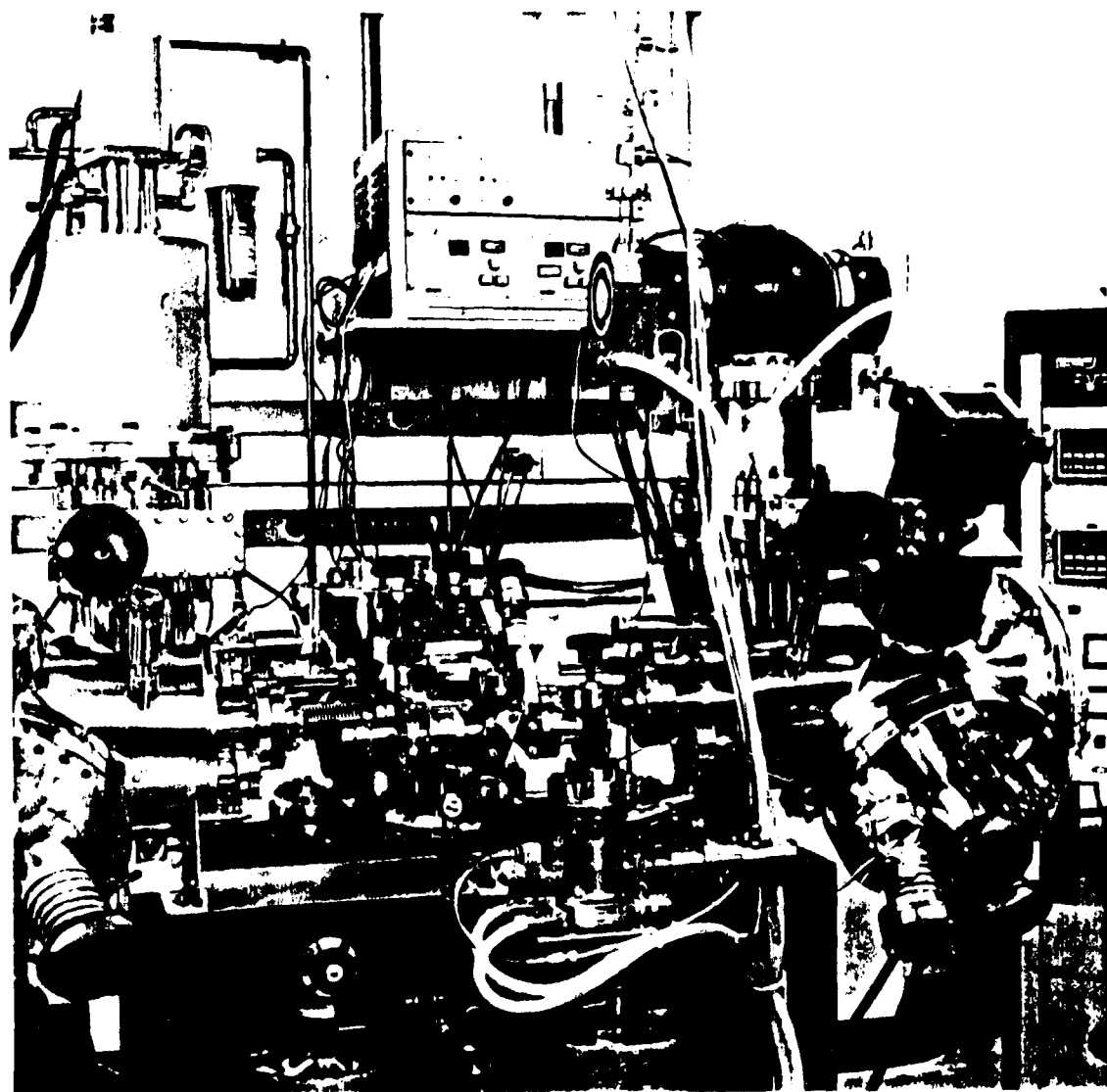

Fig. 2. Photograph of experimental apparatus ONR deposition chamber is at left. Analytical chamber is at center rear.

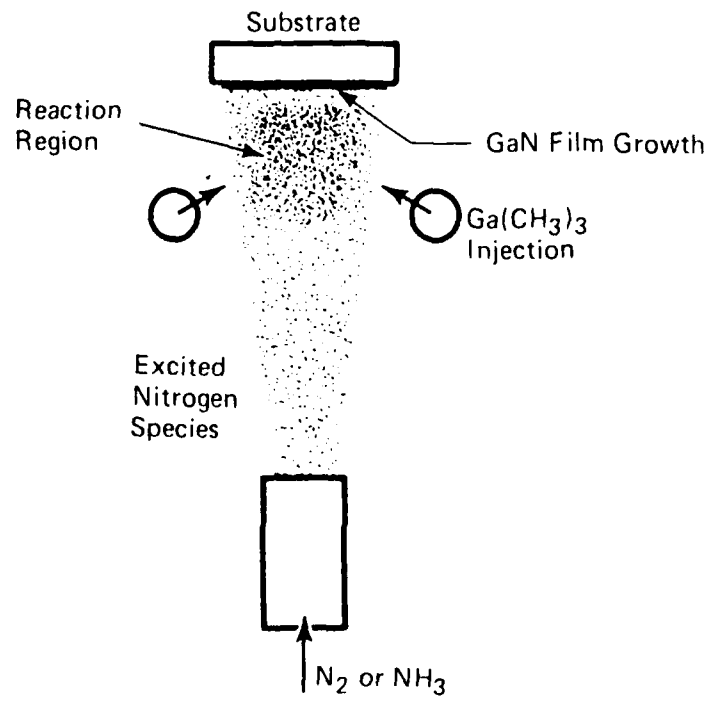
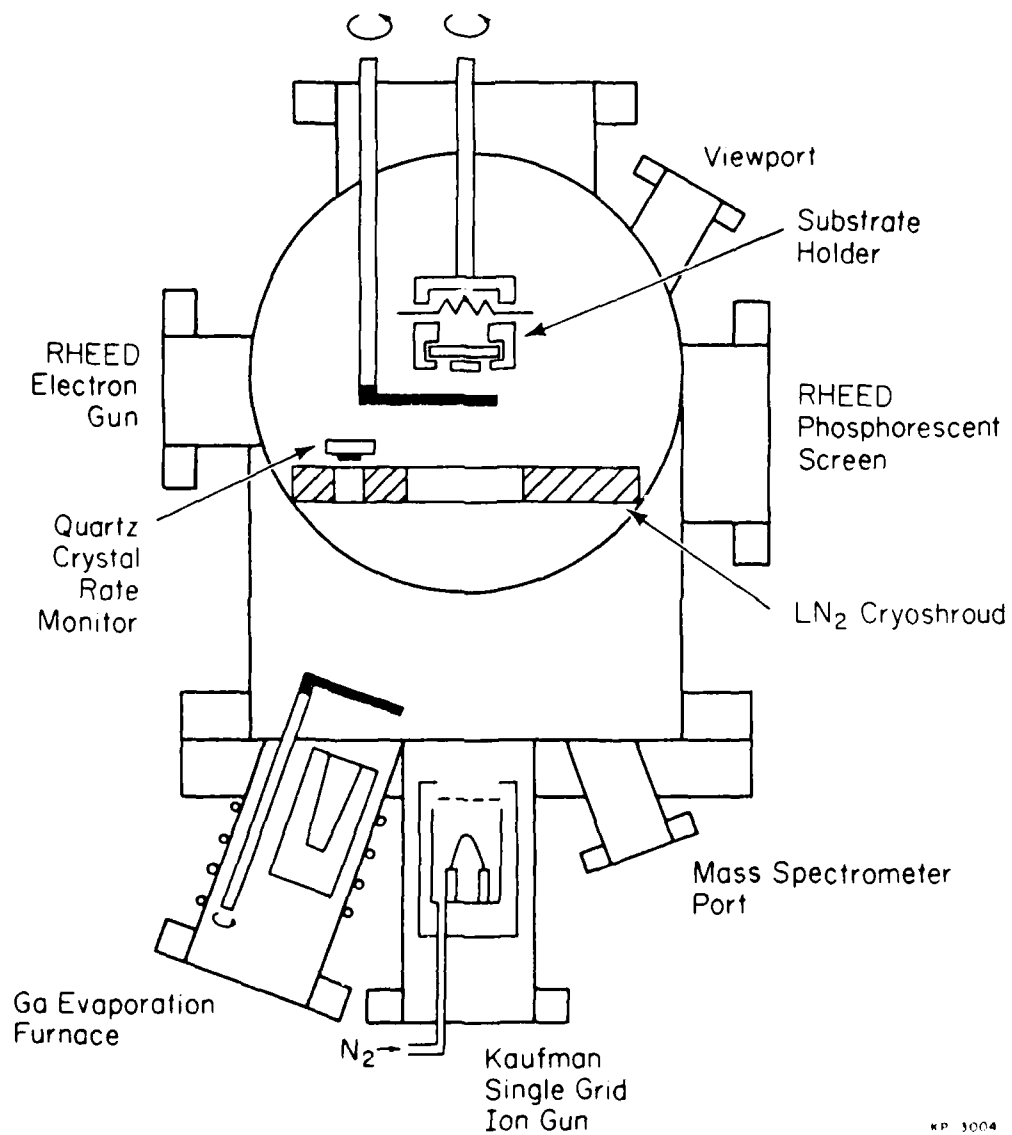
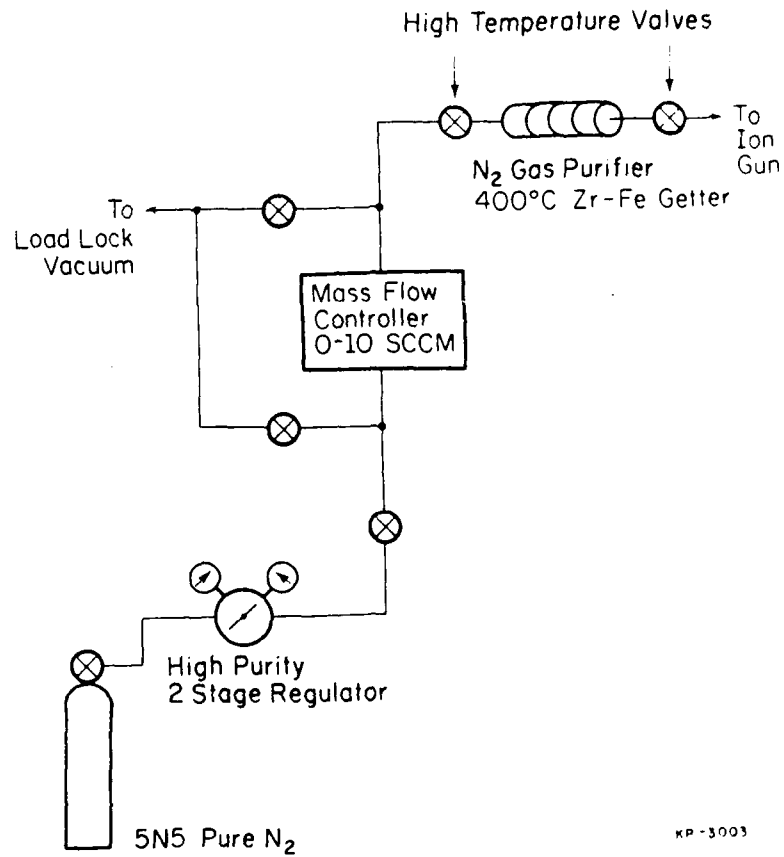

Fig. 3. Schematic illustration of gas phase plasma-assisted deposition process.



KP 3004

Fig. 4. Internal arrangement of ONR deposition chamber.



KP-3003

Fig. 5. Schematic illustration of nitrogen gas feed system designed for ion beam assisted deposition studies.

END
FILMED
FEB. 1988
DTIC