

AD-A188 827

THE PIERCE DIODE WITH AN EXTERNAL CIRCUIT II
NON-UNIFORM EQUILIBRIA(U) CALIFORNIA UNIV BERKELEY
ELECTRONICS RESEARCH LAB M S LANSON 22 JUL 87

1/1

UNCLASSIFIED

UCB/ERL-A87/52 N00014-85-K-8809

F/G 9/1

ML

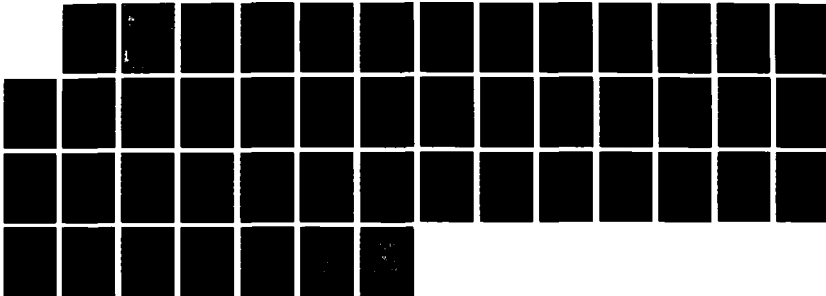

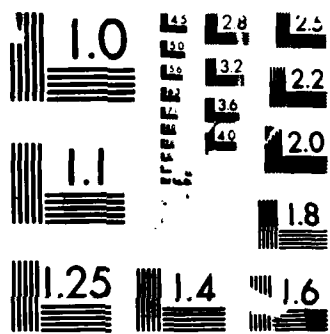

MICROCOPY RESOLUTION TEST CHART
NS 1963 A

DTIC FILE COPY

AD-A188 027

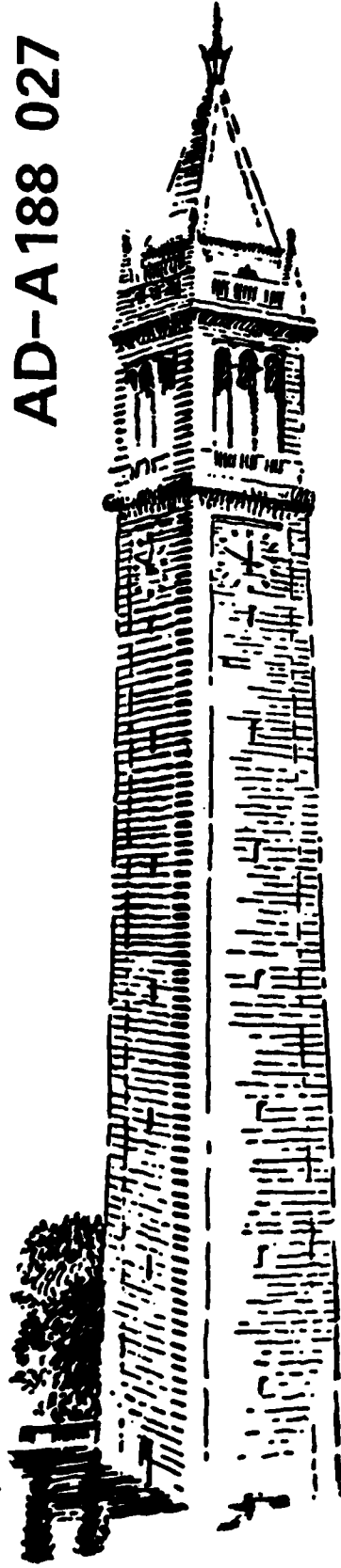

THE PIERCE DIODE WITH
AN EXTERNAL CIRCUIT. II.
NON-UNIFORM EQUILIBRIA

by
William S. Lawson

Contract N00014-85-K-0809

DTIC
ELECTE
NOV 16 1987
S D

Memorandum No. UCB/ERL M87/52

22 July 1987

DISTRIBUTION STATEMENT A
Approved for public release;
Distribution Unlimited

ELECTRONICS RESEARCH LABORATORY
College of Engineering
University of California, Berkeley, CA 94720

87 10 14 126

**THE PIERCE DIODE WITH AN EXTERNAL CIRCUIT. II.
NON-UNIFORM EQUILIBRIA**

by

William S. Lawson



Memorandum No. UCB/ERL M87/52

22 July 1987

Accession For	
NTIS CPA&I	<input checked="" type="checkbox"/>
DTIC TAB	<input type="checkbox"/>
Unannounced	<input type="checkbox"/>
Justification:	
By <i>per tti</i>	
Distribution/	
Availability Codes	
Dist	Avail and/or Status
<i>A-1</i>	

ELECTRONICS RESEARCH LABORATORY

College of Engineering
University of California, Berkeley
94720

THE PIERCE DIODE WITH AN EXTERNAL CIRCUIT. II. NON-UNIFORM EQUILIBRIA

William S. Lawson

21 July 1987

Abstract

The non-uniform (non-linear) equilibria of the classical (short circuit) Pierce diode and the extended (series RLC external circuit) Pierce diode are described theoretically, and explored via computer simulation. It is found that most equilibria are correctly predicted by theory, but that the continuous set of equilibria of the classical Pierce diode at $\alpha = 2\pi$ are not observed. The stability characteristics of the non-uniform equilibria are also worked out, and are consistent with the simulations.

Introduction

The classical Pierce diode is a theoretical model which was introduced by J. R. Pierce [1] to predict the maximum electron current which could be passed through a plasma device without instability. It consists of two parallel planes (plates or grids) and a cold electron beam traveling between them. The electrons are neutralized by a background population of infinitely massive ions. (In Pierce's model, this background was stationary, but for the purposes of this article it is better to think of them as co-moving.) The planes are connected by a wire, and so are at the same potential. The linearized behavior of this model has been studied in detail [2,3].

The extended Pierce diode is a similar device which has a passive circuit element — either a capacitor, resistor, or inductor — in place of the short circuit between the electrodes (see Fig. 1). This device is interesting as a second approximation to real bounded plasma systems. The linear behavior of this device has been worked out by Kuhn and Hörhager [4], and verified by simulation [5].

Godfrey [6] has analyzed the stationary equilibria for the classical Pierce diode, and I shall describe these first. Next the equilibria of the extended Pierce diode will be investigated by expanding on the formulas derived by Godfrey. Finally, particle simulations will be presented which test and support the predictions of the theory.

In his investigations of the classical Pierce diode, Godfrey has discovered an elegant integral equation formulation of the Pierce diode with the single requirement that the velocity of the beam be a single-valued function of position. This integral equation formulation is easily modified to cover the extended Pierce diode, and is also ideally suited for linearization about any equilibrium.

Equilibrium Theory

Although Godfrey gives the equilibrium solution, he does not derive it, so I will give a brief derivation here. The equilibrium equations are

$$\rho(x)v(x) = \rho_0 v_0 \quad (1)$$

$$v \frac{dv}{dx} = \frac{q}{m} E(x) \quad (2)$$

$$\frac{dE}{dx} = \frac{\rho - \rho_0}{\epsilon_0} \quad (3)$$

with boundary conditions

$$\rho(0) = \rho_0 \quad (4)$$

$$v(0) = v_0 \quad (5)$$

$$\int_0^l E(x) dx = -V(E(0)) \quad (6)$$

where ρ , v , E , V , q/m , and ϵ_0 represent the electron charge density, electron velocity, electric field, potential drop across the diode, electron charge-to-mass ratio, and the dielectric constant of the vacuum. The first three of these are functions of the position x . The potential drop V may be a function of the electric field because of the external circuit element. For the classical Pierce diode, $V = 0$. The potential drop cannot depend on the time derivatives of the electric field, since the problem is a static one, but this implies that there can be no current flowing in the external circuit (unless one considers the constant injection flux of electrons to be balanced by an external current instead of an equal flux of massive ions). This in turn implies that *the external resistance or inductance will have no effect on the equilibria*. Only the capacitive case will produce new equilibria.

The equations can be made dimensionless by renormalizing as follows.

$$\alpha^2 = \frac{q\rho_0 l^2}{\epsilon_0 m v_0^2} = \left(\frac{\omega_{p0} l}{v_0} \right)^2$$

$$\rho' = \frac{\rho}{\rho_0}$$

$$v' = \frac{v}{v_0}$$

$$x' = \frac{x}{l}$$

$$E' = \frac{q l}{m v_0^2} E$$

$$V' = \frac{q}{m v_0^2} V$$

Note that the charge of the electron has been absorbed into the electric field, so that the electric field is of the opposite sign as the physical electric field.

The resulting equations (dropping the primes) are

$$\rho v = 1 \quad (7)$$

$$v \frac{dv}{dx} = E \quad (8)$$

$$\frac{dE}{dx} = \alpha^2 (\rho - 1) \quad (9)$$

with boundary conditions

$$\rho(0) = 1 \quad (10)$$

$$v(0) = 1 \quad (11)$$

$$\int_0^1 E(x) dx = -V(E(0)) \quad (12)$$

To solve these equations define t such that

$$\frac{dx}{dt} = v$$

and $t = 0$ at $x = 0$. This t represents the time it took a fluid element (or particle) to arrive at position x from its time of injection. Equations 8 and 9 become

$$\frac{dv}{dt} = E \quad (13)$$

$$\frac{dE}{dt} = \alpha^2 (1 - v) \quad (14)$$

(Equation 7 was used to derive (14), and is now superfluous.) Either E or v may be eliminated to yield a harmonic oscillator equation. The solution, taking the boundary condition (11) into account is

$$E = E_0 \cos \alpha t \quad (15)$$

$$v = 1 + \frac{E_0}{\alpha} \sin \alpha t \quad (16)$$

$$x = t + \frac{E_0}{\alpha^2} (1 - \cos \alpha t) \quad (17)$$

The constant of integration E_0 represents the electric field at the injection plane, and may be either positive or negative.

A new condition is implicit in this solution; x must be a monotonically increasing function of t , so that $dx/dt = v$ must be greater than zero. Therefore we must require that

$$1 + \frac{E_0}{\alpha} \sin \alpha t > 0 \quad (18)$$

for $0 < t < T$. For most cases, this will imply the condition $|E_0| < \alpha$. Note that since v is a single-valued function of t , the condition (18) is enough to ensure that v is a single-valued function of x , which is necessary for the fluid approximation to be valid.

The condition that v be single-valued is not at all restrictive, since all equilibria of interest must satisfy this condition anyway. When the system is in equilibrium, the total energy of an electron is constant, and equal to $1/2mv^2 + q\phi$. Thus only two values of v are possible at any given position, implying that the electron trajectory can either go from the injection plane to the opposite plane without turning around at all, or it can turn around once and return to the injection plane. The case in which the electrons are turned around implies a large potential barrier, which cannot be created by the background ions, and cannot be sustained by a passive external circuit element in the face of the large ion current. Therefore, only the case in which v is a single-valued function of x is of interest.

Equation 17 applied at $x = 1$ gives an important relation between the time T that a particle or fluid element takes to transit the system, and E_0 ,

$$T = 1 - \frac{E_0}{\alpha^2} (1 - \cos \alpha T) \quad (19)$$

The second boundary condition (12) can now be applied. Let T be the time it takes a fluid element (or particle) to transit the system. The new boundary condition involves the potential drop across the system,

$$\begin{aligned}
 -V(E) &= \int_0^1 E dx \\
 &= \int_0^T E \frac{dx}{dt} dt \\
 &= \int_0^T E_0 \cos \alpha t \cdot \left(1 + \frac{E_0}{\alpha} \sin \alpha t\right) dt \\
 -V(E) &= \frac{E_0}{\alpha} \sin \alpha T \cdot \left(1 + \frac{E_0}{2\alpha} \sin \alpha T\right)
 \end{aligned} \tag{20}$$

Equilibria without a Capacitor

Let us first consider the classical Pierce diode. In this case, $V(E) = 0$, so

$$E_0 = 0 \tag{i}$$

or

$$\sin \alpha T = 0 \tag{ii}$$

or

$$\left(1 + \frac{E_0}{2\alpha} \sin \alpha T\right) = 0 \tag{iii}$$

The first case (i) is the uniform equilibrium, and the third case (iii) implies that $v(1) = -1$ which violates the condition that the velocity be positive, so the second case (ii) is the interesting one.

The solution is simply

$$T = \frac{\pi n}{\alpha} \tag{21}$$

Putting this into (19) yields two results depending on whether n is even or odd. If n is even,

$$\alpha = n\pi \tag{22}$$

and E_0 is unconstrained (except for condition (18)). If n is odd,

$$E_0 = \frac{\alpha}{2}(\alpha - n\pi) \tag{23}$$

The condition that the velocity be positive requires (except for $n = 1$ when $E_0 > 0$) that $|E_0|/\alpha < 1$. For any given n this condition limits the range of α over which a valid solution

exists. The case $n = 1$ is different for $E_0 > 0$, since $\sin \alpha t$ is always positive in this case. Thus for $n = 1$, there is no upper bound on E_0 . This equilibrium structure can be diagrammed as in Godfrey (see Fig. 2). The stability of these modes will not be dealt with systematically yet, but the equilibria with $E_0 < 0$ are, in fact, unstable while those with $E_0 > 0$ are stable. If the initial value of the electric field at the injection plane is less slightly less negative than the value E_0 for an unstable equilibrium, then the system will decay either to the uniform equilibrium (if the uniform equilibrium is stable), or to an oscillating state. If E_0 is more negative than the equilibrium value, then the growth of the unstable mode requires that a virtual cathode form.

Equilibria with a Capacitor

When the external circuit contains a capacitor, the equations become more complicated. First, let us derive the proper expression for $V(E(0))$ (which can also be written as $V(E_0)$). The voltage across the capacitor is

$$V = \frac{Q}{C}$$

where the sign of Q is chosen as in Fig. 1. The total surface charge on the injection plane must be $\sigma = Q/A$ (where A is the area of the injection plane) if the unperturbed state $E_0 = V = 0$ is to be accessible. This surface charge gives rise to the electric field at the injection plane, E_0 , such that

$$E_0 = \frac{\sigma}{\epsilon_0}$$

Putting all this together,

$$V(E_0) = \frac{\epsilon_0 A}{C} E_0 \quad (24)$$

Converting to normalized units gives

$$\begin{aligned} V'(E'_0) &= \frac{\epsilon_0 A}{lC} E'_0 \\ &= \frac{C_0}{C} E'_0 \end{aligned}$$

Where C_0 is the vacuum capacitance between the injection and collection planes. Thus, defining

$$C' = \frac{C}{C_0}$$

yields the dimensionless equation (again dropping the primes)

$$V = \frac{E_0}{C} \quad (25)$$

Equation 20 now becomes

$$\frac{E_0}{\alpha} \sin \alpha T \cdot \left(1 + \frac{E_0}{2\alpha} \sin \alpha T \right) = -\frac{E_0}{C} \quad (26)$$

This equation can be solved parametrically by setting a phase variable $\phi = \alpha T$, and combining it with (19). The result is

$$\alpha = \frac{\phi \cdot \frac{1}{2} \sin^2 \phi - \sin \phi \cdot (1 - \cos \phi)}{\frac{1}{2} \sin^2 \phi + \frac{1}{C}(1 - \cos \phi)} \quad (27)$$

$$\frac{E_0}{\alpha} = -\frac{\sin \phi + \frac{\phi}{C}}{\frac{1}{2} \sin^2 \phi + \frac{1}{C}(1 - \cos \phi)} \quad (28)$$

Figure 3 shows several diagrams like Fig. 2 which give the equilibrium values of E_0 as a function of α for various values of C . For finite values of the capacitor, it can be seen that the modes which were at $\alpha = 2n\pi$ merge with the modes which are at the next smallest value of α . For large values of C and small values of α , this merging occurs at values of E_0 which exceed the constraint (18), and so are not seen in the graphs. When the graphs are extended to unphysical values of E_0 (Fig. 4), it is seen that the curve doubles back in order to connect these modes.

Some interesting points can be shown analytically; for instance, the points at which there are bifurcations with the uniform equilibrium (*i.e.*, when $E_0 \rightarrow 0$), (26) reduces to

$$\sin \alpha = -\frac{\alpha}{C} \quad (27)$$

(since $E_0 = 0$ implies $T = 1$). These are the values of α at which the uniform equilibrium goes from stable to unstable behavior. Note that this equation has only a *finite* number of roots, implying that beyond a certain value of α (for a given C), there are no more bifurcations.

The different branches of the curves in Fig. 3 correspond to ranges of ϕ which are bounded below by an odd multiple of π , and above by an even multiple of π . Other ranges of ϕ yield a very negative E_0 . As might be expected, as $C \rightarrow \infty$, the sloping part of each branch corresponds to ϕ near to the odd multiple of π , and the part of the branch which is approaching vertical corresponds to ϕ near to the even multiple of π . It is useful to note that at $\phi = \pi$, the limit of E/α is $-\pi/2$ regardless of the value of C . While this solution at $\alpha = 0$ is of no interest physically, since it violates condition (18), it does constrain the first branch of the curve.

Simulation Results

The particle simulation code PDW1 [7] was used to simulate the expected equilibria. As with the theory, the simulation results will be broken up into classical (short circuit) and extended (capacitive external circuit). The simulation parameters are shown in Table I.

Classical Pierce Diode

The easiest equilibria to simulate are the stable ones. To simulate these, the uniform equilibrium was given a slight perturbation, and the equilibria came about naturally. Figures 5-7 show the phase space plots after equilibrium has been reached, and time histories of the electric field at $x = 0$ as the simulation approaches equilibrium for α equal to $3\pi/2$, $7\pi/2$, and $11\pi/2$. These equilibria were observed by Crystal and Kuhn [3], although they did not compare them with theory. While in all three cases the electric field at $x = 0$ settles down rapidly to the average value predicted by (23), the results are not without surprises. The electric field at $x = 0$ for both $\alpha = 7\pi/2$ and $\alpha = 11\pi/2$ shows oscillations about the equilibrium value which are only weakly damped. These oscillations will be examined shortly, when the general issue of stability will be addressed.

The stable equilibrium with $n = 1$ extends to all values of $\alpha > \pi - 2$. This can also be simulated in regions where other equilibria are preferred, such as $\alpha = 5\pi/2$. To do this, it is not enough to perturb the uniform equilibrium, since this perturbation will not grow to the desired equilibrium. Instead, the electric field at the injection plane E_0 is held fixed at the predicted equilibrium value, overriding the circuit condition for one transit time. This constraint should force the desired equilibrium. After a transit time (or more), the constraint can be removed, and the self-consistent circuit condition reinstated. The result for $\alpha = 5\pi/2$ is shown in Fig. 8. There are no oscillations about the equilibrium value of E_0 . Table II summarizes the results for the stable equilibria. The values for $\alpha = 3\pi/2$ and $\alpha = 5\pi/2$ are extraordinarily accurate, but the values for $\alpha = 7\pi/2$ and $\alpha = 11\pi/2$ seem to deviate significantly. Halving the grid spacing and the time step reduced the error for $\alpha = 11\pi/2$ from 5% to 1.5%, and Richardson extrapolation assuming second order accuracy reduces this to 0.5%, so it appears that the deviation is of numerical rather than physical origin.

The unstable equilibria are rather difficult to simulate. One approach is to again fix E_0 , overriding the circuit constraint, at a value either above or below the predicted equilibrium value of E_0 for a transit time, then restore the circuit constraint and see whether the simulation moves away from the predicted equilibrium. This was done for the $\alpha = \pi/2$ equilibrium. The predicted value for E_0 in equilibrium is $E_0 = -\pi^2/8 \approx -1.23$, so two simulations were run at initial values of E_0 at -1.2 and -1.3 (recall that the sign of E_0 is different in the theory from the simulations with negatively charged electrons). The results of the simulation starting at $E_0 = -1.2$ are shown in Fig. 9. The system quickly settles to the stable uniform equilibrium ($E_0 = 0$, $v = 1$). When $E_0 = -1.3$,

however, a virtual cathode forms (see Fig.10). If the duration of the simulation is increased, it is seen that a very regular, though non-sinusoidal, virtual cathode oscillation has set in (see Fig. 11). Recall that this oscillation occurs at a value of α which is only half of the value at which the Pierce diode first becomes linearly unstable.

The unstable equilibrium at $\alpha = 5\pi/2$ was also simulated. The results are shown in Fig. 12. Since no regular virtual cathode oscillations were expected (and none were found), E_0 was again fixed for a transit time, this time at exactly the value predicted for the equilibrium. There are two pieces of evidence that the predicted equilibrium exists at very nearly the predicted value of E_0 . First, the potential returns almost to zero at $x = 1$, and second, when released, the growth away from the equilibrium appears to be exponential rather than linear. The equilibrium is marred by the presence of two trapped electrons (just visible near $x = .75$ and $x = .85$, slightly below the passing electrons). According to continuum theory, these trapped particles should not be there, but the errors inherent in simulation allow them to become trapped during the initial transient (the diode is initially in the uniform state). If these particles were not there, the agreement might be even better.

The equilibria at $\alpha = 2n\pi$ are especially interesting because any value of E_0 which does not violate (18) should be a valid equilibrium. Trouble can be expected, however, since the dispersion relation of the uniform equilibrium has a double root of zero at $\alpha = 2n\pi$, implying a secular instability (linear growth with time). This secular instability may (and the section on stability will show shortly that it does) extend to the non-uniform equilibria. This secular instability is of interest, but my simulation efforts have not met with success. Particle simulation at $\alpha = 2\pi$ produces a slowly but exponentially growing mode, and a simulation based on Godfrey's integral equation formulation produces a mode which oscillates slowly about the uniform equilibrium with large amplitude. The reason for the failure of these simulations seems to be the singular nature of the $\alpha = 2n\pi$ points. For values of α near these points, the dominant solution of the dispersion relation varies as $\theta \sim (2n\pi - \alpha)^{1/2}$. Thus, a very small numerical error can produce relatively large deviations. For instance an error which alters the effective value of α by 1/1000, may create a growth rate or frequency of 1/30, which is quite noticeable in simulation.

Equilibria with External Capacitor

To test the predictions for the equilibria with an external capacitor, α was again chosen to be half-integer multiples of π in the simulations. The results for the stable equilibria are in Table III.

The results are very good for $\alpha = 3\pi/2$, and somewhat less good for $\alpha = 7\pi/2$. As was demonstrated for the short circuit case, this less-accurate agreement is most likely due to the error inherent in the simulation, since the time step is larger relative to a plasma period (i.e., $\omega_p \Delta t$ is larger).

Interestingly, the equilibrium for $\alpha = 7\pi/2$ and $C = 20$ is not truly stable. There is an oscillatory mode which has a small but unmistakable growth rate (see Fig. 13). This growth will be explained in the next section.

The unstable equilibrium at $\alpha = 7\pi/2$ and $C = 10$ was also simulated, and the phase space plot is shown in Fig. 14. The growth rate for this mode is quite slow relative to the unstable equilibria in the short circuit case.

Stability of Non-uniform Equilibria

The most direct method of analyzing the stability of an equilibrium is to compute the spectrum of linear perturbations about that equilibrium. Fortunately this is possible for the extended Pierce diode. One simple method of doing this is to extend the set of integral equations discovered by Godfrey for the classical Pierce diode. Godfrey's integral formulation of the Pierce diode, extended to the case with an external circuit, is comprised of the two integro-differential equations

$$T(t) - 1 = -\frac{1}{\alpha} \int_{t-T}^t E(\tau) \sin \alpha(t - \tau) d\tau \quad (28)$$

and

$$\left(L \frac{d^2}{dt^2} + R \frac{d}{dt} + \frac{1}{C} + 1 \right) E(t) = \frac{\alpha^2}{2} (1 - T(t)^2) - \alpha \int_{t-T}^t E(\tau)(t - \tau) \sin \alpha(t - \tau) d\tau \quad (29)$$

where x and t represent position and time respectively, E represents the e^+ field at the injection plane, T represents the transit time of the electron just leaving the system, α is the classical Pierce parameter, and R , L , and C represent the external resistance, inductance, and capacitance. All these quantities have been normalized (see Appendix A for a complete description of the normalization factors and a derivation of (28) and (29)).

These equations are ideally suited to linearization about non-uniform equilibria.

Linearization About an Equilibrium

Assume that $E = E_0$, $T = T_0$ is a solution of (28) and (29) for some given α and C , then (28)

and (29) can be linearized.

$$\begin{aligned}\delta T &= -\frac{1}{\alpha} \int_{t-T}^t \delta E(\tau) \sin \alpha(t-\tau) d\tau - \frac{1}{\alpha} \int_{t-T}^{t-T_0} E_0 \sin \alpha(t-\tau) d\tau \\ &\approx -\frac{1}{\alpha} \int_{t-T_0}^t \delta E(\tau) \sin \alpha(t-\tau) d\tau - \frac{E_0}{\alpha} \sin \alpha T_0 \cdot \delta T\end{aligned}$$

so

$$\left(1 + \frac{E_0}{\alpha} \sin \alpha T_0\right) \delta T = -\frac{1}{\alpha} \int_{t-T_0}^t \delta E(\tau) \sin \alpha(t-\tau) d\tau \quad (30)$$

The equation for $E(t)$ can be similarly linearized.

$$\begin{aligned}\left(L \frac{d^2}{dt^2} + R \frac{d}{dt} + \frac{1}{C} + 1\right) \delta E &= -\alpha^2 T_0 \delta T - \frac{\alpha^2}{2} (\delta T)^2 \\ &\quad - \alpha \int_{t-T}^t \delta E(\tau)(t-\tau) \sin \alpha(t-\tau) d\tau \\ &\quad - \alpha \int_{t-T}^{t-T_0} E_0(t-\tau) \sin \alpha(t-\tau) d\tau \\ &\approx -\alpha^2 T_0 \left(1 + \frac{E_0}{\alpha} \sin \alpha T_0\right) \delta T - \int_{t-T_0}^t \delta E(\tau)(t-\tau) \sin \alpha(t-\tau) d\tau\end{aligned}$$

Substituting in (30),

$$\begin{aligned}\left(L \frac{d^2}{dt^2} + R \frac{d}{dt} + \frac{1}{C} + 1\right) \delta E &= \alpha \int_{t-T_0}^t \delta E(\tau)(T_0 - t + \tau) \sin \alpha(t-\tau) d\tau \\ &= \alpha \int_0^{T_0} \delta E(t-t')(T_0 - t') \sin \alpha t' dt'\end{aligned} \quad (31)$$

Both sides of (31) are linear in δE , so a solution of the form $\delta E = \exp(\theta t)$ can be sought. When this form for δE is substituted into (31), the result is

$$\begin{aligned}L\theta^2 + R\theta + \frac{1}{C} + 1 &= \alpha \int_0^{T_0} e^{-\theta t'} (T_0 - t') \sin t' dt' \\ &= \frac{\alpha^2 T_0}{\alpha^2 + \theta^2} - \frac{\alpha}{(\alpha^2 + \theta^2)^2} [2\alpha\theta (1 - e^{-T_0\theta} \cos \alpha T_0) + (\alpha^2 - \theta^2) \sin \alpha T_0] \quad (32)\end{aligned}$$

Note that this equation does not contain E_0 .

This formula (without the external circuit elements) was first derived by Godfrey. It can now be applied to some special cases of interest.

Uniform Equilibrium

In the uniform ($E = 0$ for all x) equilibrium $T_0 = 1$, so

$$L\theta^2 + R\theta + \frac{1}{C} + \frac{\theta^2}{\alpha^2 + \theta^2} + \frac{\alpha}{(\alpha^2 + \theta^2)^2} [2\alpha\theta (1 - e^{-\theta} \cos \alpha) + (\alpha^2 - \theta^2) \sin \alpha] = 0 \quad (33)$$

This is the dispersion relation found by Kuhn and Hörhager [4], which has been verified by simulations [5].

Non-uniform Equilibrium with Short Circuit

As Godfrey showed, the non-uniform equilibria when the external circuit is a short (classical Pierce diode) are of two classes depending on whether an integer parameter n is odd or even. When n is even, the equilibrium is given by $\alpha = n\pi$, $T_0 = 1$, and E_0 with any value as long as $-\alpha < E_0 < \alpha$ (as per Equation 22). Putting these values into (32) with $L = R = 1/C = 0$ gives

$$\frac{\theta^2}{n^2\pi^2 + \theta^2} + \frac{2n^2\pi^2\theta}{(n^2\pi^2 + \theta^2)^2} (1 - e^{-\theta}) = 0 \quad (34)$$

Note that the same dispersion equation applies for all values of E_0 . The dominant root of this equation is $\theta = 0$, which is a double root, implying that a secular instability is possible. As was mentioned, this secular instability was not observed in simulations, and the singular behavior near $\alpha = n\pi$ with n even seems to be responsible for the poor simulation results.

When n is odd, $T_0 = n\pi/\alpha$, and $E_0 = \frac{1}{2}\alpha(\alpha - n\pi)$. Substituting these values into (32) gives

$$1 - \frac{n\pi\alpha}{\alpha^2 + \theta^2} + \frac{2\alpha^2\theta}{(\alpha^2 + \theta^2)^2} \left[1 + \exp\left(-\frac{n\pi}{\alpha}\theta\right) \right] = 0 \quad (35)$$

Figures 15-17 show the dominant solutions of this dispersion relation as a function of α for the regions of interest ($n\pi - 2 < \alpha < n\pi + 2$) for $n = 1, 3, 5$. For $n\pi - 2 < \alpha < n\pi$, the dominant mode is purely growing in all cases. For $n\pi < \alpha < n\pi + 2$, the dominant mode is always purely damped for $n = 1$, but for $n > 1$ a second mode, which is damped and oscillatory, appears, and seems to touch $\text{Re}\theta = 0$. This is not an illusion, and the values of α at which the real part of the eigenvalue θ is zero can be found by setting $\theta = i\omega$ and setting the real and imaginary parts of (35) to zero. The result is a Diophantine equation,

$$\frac{\alpha}{\pi} - n = \frac{nm^2}{n^2 - m^2} \quad (36)$$

in which m must be odd. Only values of $\alpha/\pi - n$ between $-2/\pi$ and $2/\pi$ are of interest. In this region, one quickly finds that

$$n > \left(\frac{\pi}{2} + \frac{1}{n}\right)m^2$$

is a necessary condition. From this it is plain that for $n = 1$, no such solutions are expected, and for $n = 3$ and $n = 5$, one such solution is expected. Two solutions will not appear until $n = 15$.

The simulations from the previous article agree with the predictions of this dispersion relation as well as can be determined from the graphs (the eigenvalues were not computed numerically from the simulations).

The case in which θ is purely imaginary is of special interest, since any growth or decay must be determined by non-linear effects. Figure 18 shows the result of simulating the marginally stable case at $\alpha = (3 + 3/8)\pi$. The simulation moves toward equilibrium and quickly reaches a steady oscillation of small amplitude about the equilibrium.

Equilibria with an External Capacitor

The equilibria with external capacitance were worked out earlier, such that α , T_0 , and E_0 are all functions of $\phi = \alpha T_0$. These can be plugged into (32), and (32) can then be solved numerically. Figures 19-21 show the eigenvalues, θ , as functions of α for several different values of C . The range of α in the plots is again from $n\pi - 2$ to $n\pi + 2$, although this is no longer quite the right range physically. Note that the oscillatory modes which were stable in the short circuit case have become unstable for some values of α with the addition of an external capacitor, counter to the stabilizing influence of the capacitor on the modes of the uniform equilibrium. These theoretical results agree with the simulation results obtained earlier.

The newly unstable modes are the most interesting ones. A natural question is whether they saturate at some finite amplitude due to non-linear effects. Figure 22 shows that for $C = 20$, the $\alpha = 7/2\pi$ case, at least, does not. The initial transient brings the system close to the (unstable) equilibrium (at $t \sim 10$), but then the instability takes over, and grows until finally electrons are turned back to the injection plane. Since their charge remains on the left side of the system (and the left side of the external capacitor), the system is no longer in a state which allows the unperturbed ($E_0 = 0$, $V = 0$) equilibrium, and so the resulting equilibrium (shown at $t = 64$) has not been included in my analysis of equilibria. (Such equilibria could be worked out, but require the addition of another parameter, specifically, the sum of the charge on the injection plane and the side of the capacitor tied to it.)

Once a certain amount of charge has been returned to the emission plane, the system is in an equilibrium which has a stable spectrum. Interestingly, the potential drop across the system in this new equilibrium is nearly zero. It seems unlikely that this could be coincidence, but it also seems

unlikely that a gross process such as virtual cathode formation could return precisely the correct amount of charge for this to occur.

Conclusion

The theory for non-uniform (non-linear) equilibria of the Pierce diode with an external capacitor instead of a short circuit between its electrodes was worked out, and simulations were performed which verified the theory for both the capacitive Pierce diode, and the classical Pierce diode.

The spectra of oscillations about non-uniform equilibria of the Pierce diode with and without an external capacitor have also been calculated and the results are consistent with the simulation results, although the simulations were not examined to high precision.

Of particular interest is the observation that strong, regular virtual cathode oscillations can occur at current levels which are much smaller than the current level at which the Pierce diode becomes linearly unstable (simulations were performed at one quarter of this current value). As Godfrey showed, it is also possible to exceed the current level at which the Pierce diode becomes unstable by any amount desired, *if the proper stable non-uniform equilibrium can be attained.*

The effect of the external capacitor is to stabilize the linear modes somewhat, and also to increase the current value at which virtual cathode oscillations can be excited. The external capacitance has the detrimental effect, however, of limiting the maximum current which can be carried by the non-linear modes. The most useful mode ($n = 1$) ceases to exist for values of α greater than some maximum, and the other modes tend to become unstable.

Acknowledgments

I gratefully acknowledge the valuable advice and assistance of Professor C. K. Birdsall and Dr. T. L. Crystal. I also thank Dr. B. Godfrey for his assistance and encouragement. This work was performed under Department of Energy contract DE-AT03-76ET53064 and Office of Naval Research contract N00014-85-K-0809. The simulations were performed on the computers of the National Magnetic Fusion Energy Computer Center at the Lawrence Livermore National Laboratory.

APPENDIX A: Derivation of Integral Equations

Renormalization of Equations

The physical equations of evolution are

$$\frac{\partial \rho}{\partial t} + \frac{\partial}{\partial x}(\rho v) = 0 \quad (a1)$$

$$\left(\frac{\partial}{\partial t} + v \frac{\partial}{\partial x} \right) v = \frac{q}{m} E \quad (a2)$$

$$\frac{\partial E}{\partial x} = \frac{\rho - \rho_0}{\epsilon_0} \quad (a3)$$

and

$$V = L \frac{d^2 Q}{dt^2} + R \frac{dQ}{dt} + \frac{Q}{C} \quad (a4)$$

with boundary conditions of, respectively,

$$\rho(x=0) = \rho_0 \quad (a5)$$

$$v(x=0) = v_0 \quad (a6)$$

$$E(x=0) = \frac{Q}{A\epsilon_0} \quad (a7)$$

$$\int_0^l E dx = -V \quad (a8)$$

The initial conditions must also be specified. The independent variables are x (position) and t (time). The dependent variables are ρ (charge density), v (velocity), E (electric field), V (voltage across the system), and Q (charge on the capacitor). The last two (V and Q) depend only on time. The constants in the equations are q/m (electron charge-to-mass ratio), ϵ_0 (dielectric constant of the vacuum), ρ_0 (equilibrium charge density), v_0 (injection velocity), l (length of the system), A (area of end plates), L (external inductance), R (external resistance), C (external capacitance), Q_0 (initial charge on capacitor), I_0 (initial current through external circuit). The condition that the electric field at $x=0$ be proportional to the charge on the capacitor could be relaxed to allow for a constant offset, but then the $Q = E = 0$ state would not be an allowed state, and this is the desired equilibrium.

These equations can be renormalized reducing them to two independent variables, three independent variables, four parameters and initial conditions as follows. First define

$$\alpha^2 = \frac{q\rho_0 l^2}{\epsilon_0 m v_0^2} = \left(\frac{\omega_p l}{v_0} \right)^2$$

and

$$E_0(t) = E(x = 0, t)$$

then setting

$$x' = \frac{x}{l}$$

$$t' = \frac{v_0}{l} t$$

$$\rho' = \frac{\rho}{\rho_0}$$

$$v' = \frac{v}{v_0}$$

$$E' = \frac{ql}{mv_0^2} E$$

$$C' = \frac{l}{A\epsilon_0} C$$

$$R' = \frac{v_0 A \epsilon_0}{l^2} R$$

$$L' = \frac{v_0^2 A \epsilon_0}{l^3} L$$

yields the equations (dropping the primes)

$$\frac{\partial \rho}{\partial t} + \frac{\partial}{\partial x}(\rho v) = 0 \quad (\text{a9})$$

$$\left(\frac{\partial}{\partial t} + v \frac{\partial}{\partial x} \right) v = E \quad (\text{a10})$$

$$\frac{\partial E}{\partial x} = \alpha^2(\rho - 1) \quad (\text{a11})$$

and

$$\int_0^1 E dx = - \left(L \frac{d^2}{dt^2} + R \frac{d}{dt} + \frac{1}{C} \right) E_0 \quad (\text{a12})$$

with boundary conditions

$$\rho(x = 0) = 1$$

and

$$v(x = 0) = 1$$

Derivation of Integro-differential Equations

We begin by taking the partial derivative with respect to time of (a11), and using (a9) to substitute for the partial derivative of ρ with respect to time. The result is the familiar (aside from

the appearance of α^2) equation

$$\frac{\partial}{\partial x} \left(\frac{\partial E}{\partial t} + \alpha^2 \rho v \right) = 0$$

This equation implies that the quantity inside the parentheses is a function only of time. We can therefore take its value for any value of x to be its value at $x = 0$, so that

$$\frac{\partial E}{\partial t} + \rho v = \frac{\partial E_0}{\partial t} + \alpha^2 \quad (a13)$$

The left-hand side of this equation can be rewritten as

$$\begin{aligned} \frac{\partial E}{\partial t} + \rho v &= \frac{\partial E}{\partial t} + v \frac{\partial E}{\partial x} + v \left(\rho - \frac{\partial E}{\partial x} \right) \\ &= \frac{dE}{dt} + \alpha^2 v \\ &= \frac{d^2 v}{dt^2} + \alpha^2 v \end{aligned}$$

yielding

$$\frac{d^2 v}{dt^2} + \alpha^2 v = \frac{dE_0}{dt} + \alpha^2 \quad (a14)$$

This equation is analogous to the Llewellyn equation [8] for electron beams ($\bar{v} = J(t)$). Since $v = dx/dt$, this equation can be integrated once with respect to time. Let t_0 be the time at which a particle (or fluid element) at time t and position x was emitted at $x = 0$, then

$$\begin{aligned} \frac{dv}{dt} \Big|_t - \frac{dv}{dt} \Big|_{t_0} + \alpha^2 x &= E_0(t) - E_0(t_0) + \alpha^2(t - t_0) \\ \frac{d^2 x}{dt^2} + \alpha^2 x &= E_0 + \alpha^2(t - t_0) \end{aligned} \quad (a15)$$

The boundary conditions on this equation are

$$x(t = t_0) = 0$$

and

$$\frac{dx}{dt} \Big|_{t=t_0} = 1$$

The solution, by standard methods of calculus, is

$$x = t - t_0 + \frac{1}{\alpha} \int_{t_0}^t \dot{E}_0(\tau) \sin \alpha(t - \tau) d\tau \quad (a16)$$

Let T be the transit time of the particles just leaving the system, i.e., $x = 1$ when $t - t_0 = T$. Note that T is a function of time. The first of the two integro-differential equations to be derived is

$$T - 1 = -\frac{1}{\alpha} \int_{t-T}^t E_0(\tau) \sin \alpha(t - \tau) d\tau \quad (\text{a17})$$

So far, t_0 has been viewed as a parameter in a solution by characteristics, but a more powerful, and now necessary view is that we have made a change in independent variable. To consider t_0 to be an independent variable, and x a function of it, it is necessary only to show that the differential operator we have been denoting as d/dt is actually the partial derivative with respect to t with t_0 held fixed.

$$\begin{aligned} \left. \frac{\partial}{\partial t} \right|_x + v \left. \frac{\partial}{\partial x} \right|_t &= \left. \frac{\partial}{\partial t} \right|_{t_0} + \left. \frac{\partial t_0}{\partial t} \right|_x \cdot \left. \frac{\partial}{\partial t_0} \right|_t + v \left. \frac{\partial t_0}{\partial x} \right|_t \cdot \left. \frac{\partial}{\partial t_0} \right|_t \\ &= \left. \frac{\partial}{\partial t} \right|_{t_0} - \left. \frac{\partial x}{\partial t} \right|_{t_0} \cdot \left. \frac{\partial t_0}{\partial x} \right|_t \cdot \left. \frac{\partial}{\partial t_0} \right|_t + v \left. \frac{\partial t_0}{\partial x} \right|_t \cdot \left. \frac{\partial}{\partial t_0} \right|_t \\ &= \left. \frac{\partial}{\partial t} \right|_{t_0} \end{aligned}$$

We are now free to make use of t_0 as an independent variable.

Using this change of variable, we can integrate the electric field to find the potential drop across the system, in order to convert (a12) into an integro-differential equation.

$$\int_0^1 E(x, t) dx = \int_t^{t-T} E(t_0, t) \frac{dx}{dt_0} dt_0 \quad (\text{a18})$$

Note that it is necessary to assume at this point that x is a monotonic function of t_0 . Since dx/dt_0 is negative for small values of E_0 , it follows that the condition

$$-\frac{dx}{dt_0} = 1 + \frac{1}{\alpha} E_0(t_0) \sin \alpha(t - t_0) > 0 \quad (\text{a19})$$

be true for all $t - T < t_0 < t$. This condition will always be satisfied if $|E + 0| < \alpha$.

Since x is known explicitly as a function of t and t_0 , and

$$E = \frac{d^2 x}{dt^2}$$

the integral can be reduced to a single explicit integral. The algebra is lengthy but straight-forward, and will not be reproduced here. The only difficult points come when one must use the identities

$$\begin{aligned} \int_a^b dx \int_x^b dy f(y) &= \int_a^b dy \int_a^y dy f(y) \\ &= \int_a^b (y - a) f(y) dy \end{aligned}$$

and

$$\int_a^b dx \int_x^b dy f(x)f(y) = \frac{1}{2} \left[\int_a^b f(x) dx \right]^2$$

The final result is

$$\int_0^1 E(x, t) dx = E_0 - \frac{\alpha^2}{2}(1 - T^2) + \alpha \int_{t-T}^t E_0(\tau)(t - \tau) \sin \alpha(t - \tau) d\tau \quad (a20)$$

Plugging this into (a12) gives the desired integro-differential equation

$$\left(L \frac{d^2}{dt^2} + R \frac{d}{dt} + \frac{1}{C} + 1 \right) E_0 = \frac{\alpha^2}{2}(1 - T^2) - \alpha \int_{t-T}^t E_0(\tau)(t - \tau) \sin \alpha(t - \tau) d\tau \quad (a21)$$

References

- [1] J. R. Pierce, *J. Appl. Phys.* 15(1944), 721
- [2] J. R. Cary and D. S. Lemons, *J. Appl. Phys* 53(1982), 3303
- [3] T. L. Crystal and S. Kuhn, *Phys. Fluids* 28(1985), 2116
- [4] S. Kuhn and Hörhager, *J. Appl. Phys.* 60(1986), 1952
- [5] Wm. S. Lawson, "The Pierce Diode with an External Circuit. I. Simulations in the Linear Regime" to be submitted to *Phys. Fluids*
- [6] B. B. Godfrey, *Phys. Fluids* 30(1987), 1553
- [7] Wm. S. Lawson, "PDW1 User's manual", University of California, Berkeley, Electronics Research Laboratory memo UCB/ERL M84/37, 1984
- [8] F. B. Llewelyn, "Electron Inertia Effects", Cambridge University Press, London and New York, 1941

System length	1
Number of grid cells	128
Time step	1/128
Number of time steps	2048
ϵ_0	1
q_e/m_e	-1
m_i	∞
v_0	1
Injected electron current	$-\alpha^2$
Background current	α^2
Injected electron flux	2048

Table I. Simulation parameters

EQUILIBRIA FOR CLASSICAL PIERCE DIODE

α	E_0 Theory	E_0 Simulation
$3\pi/2$	-3.70110	-3.7009
$5\pi/2$	-18.50551	-18.5061
$7\pi/2$	-8.63590	-8.528
$11\pi/2$	-13.57071	-12.895 (-13.357)*

Table II. Values of the electric field at the cathode for different values of α .* Δx and Δt reduced by half

EQUILIBRIA FOR EXTENDED PIERCE DIODE

<i>C</i>	E_0 Theory	E_0 Simulation	α
20	-3.1399	-3.1398	$3\pi/2$
10	-2.5306	-2.5306	
5	-0.4863	-0.4885	
20	-5.3689	-5.336	$7\pi/2$

Table III. Values of the electric field at the cathode for different values of α and C .

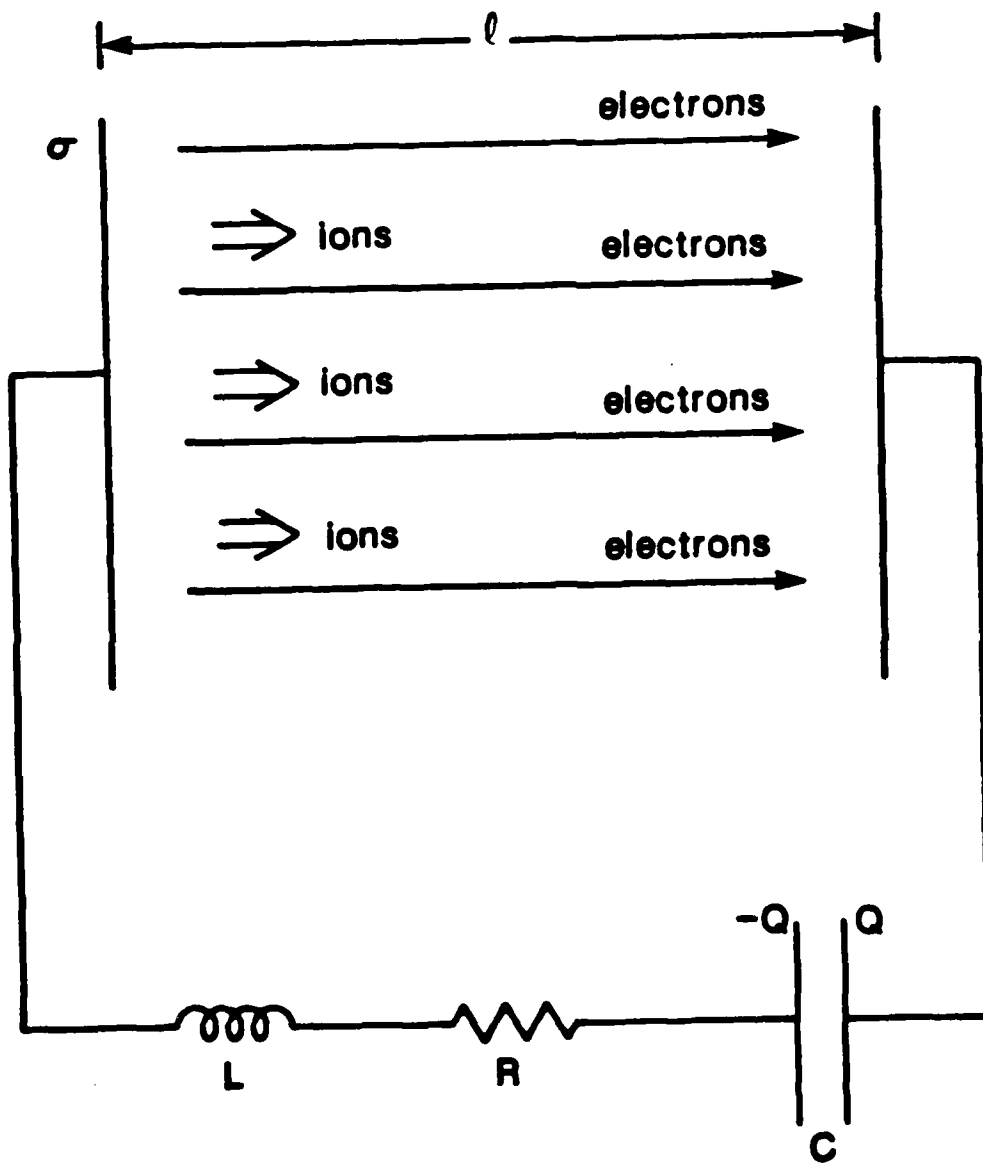

Fig. 1. Extended Pierce Diode model

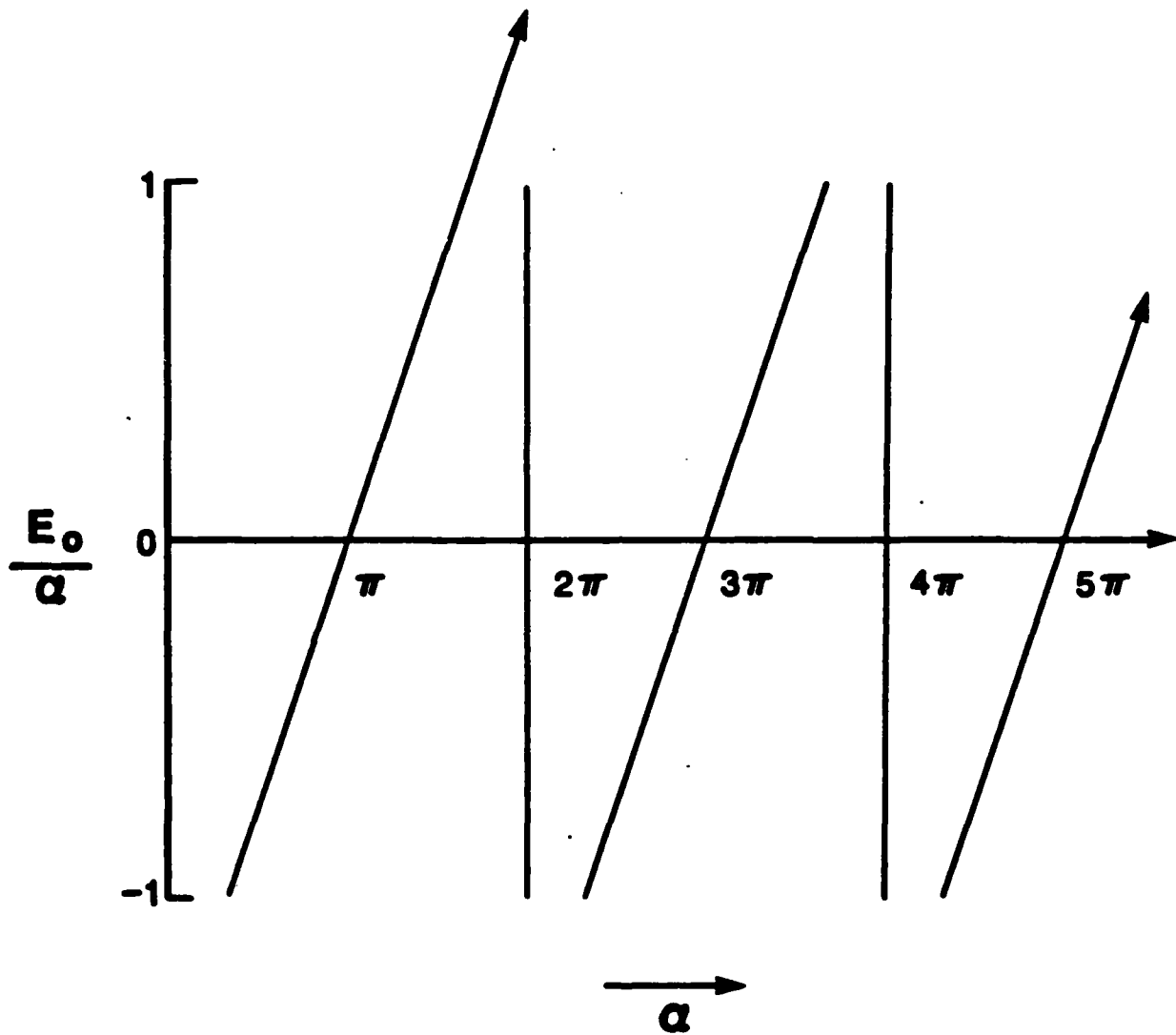
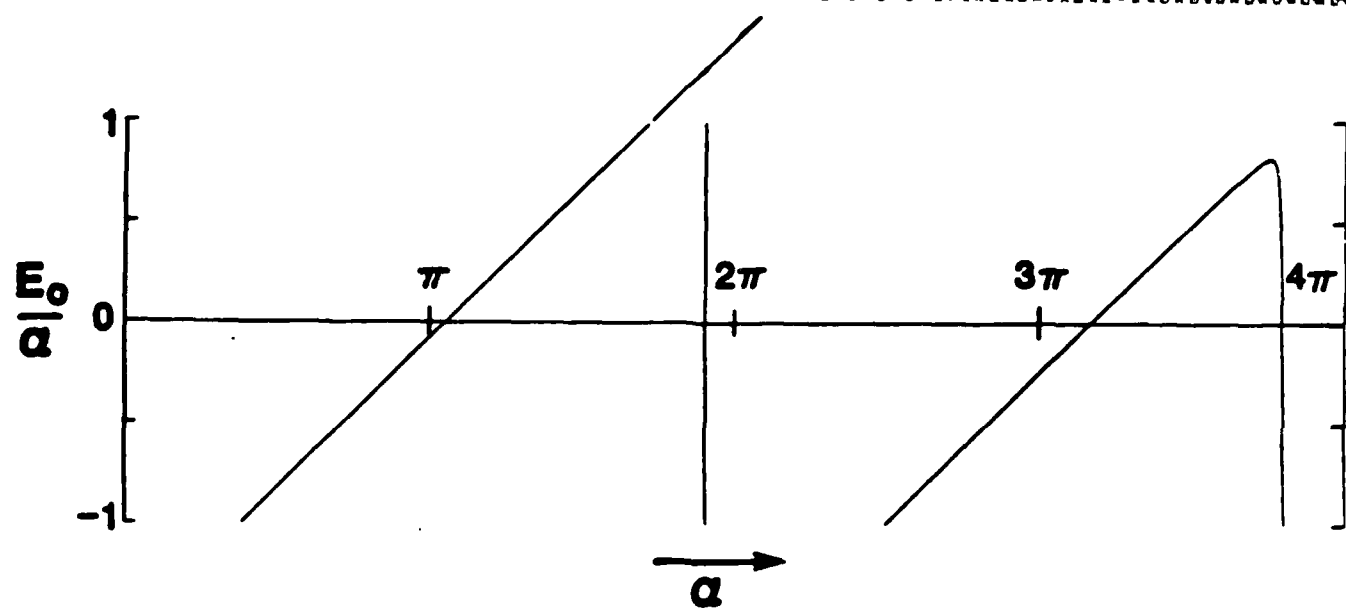
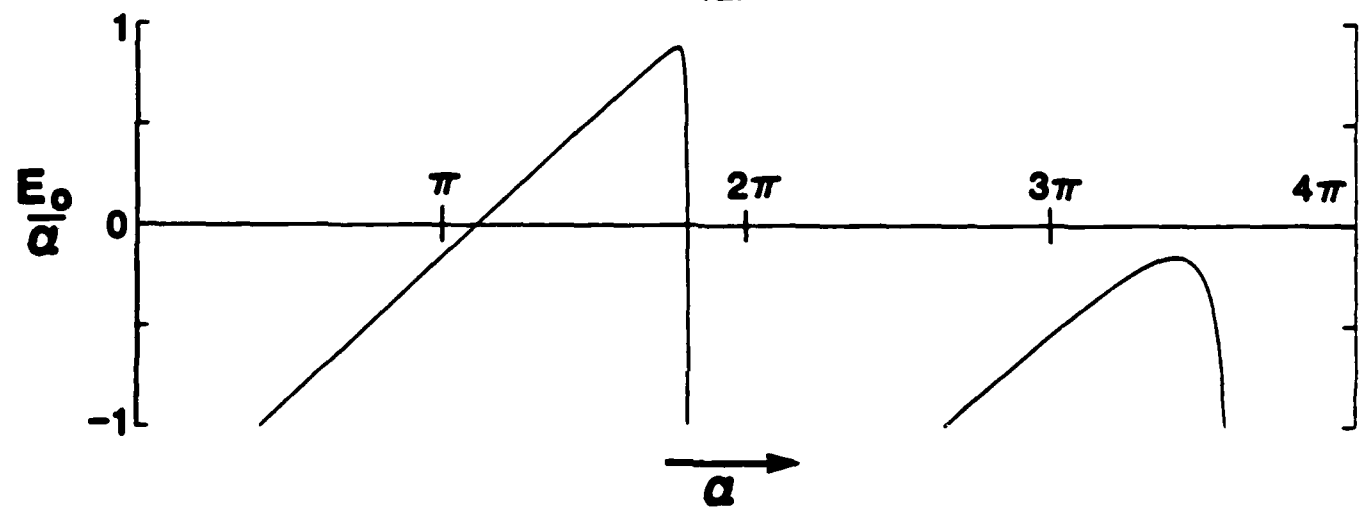

Fig. 2. Non-uniform equilibria for short circuit ($C = \infty$) case. All lines end at $|E_0| = \alpha$, except for first line (with arrow), which extends indefinitely.



(a)



(b)

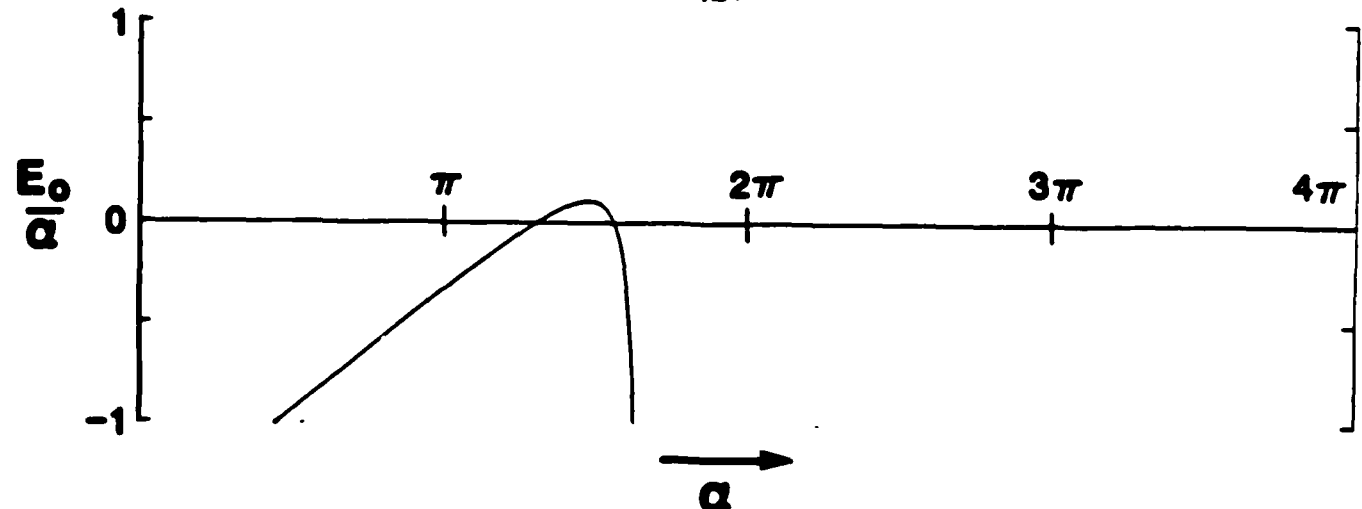

(c)

Fig. 3. Non-uniform equilibria for (a) $C = 20$, (b) $C = 10$, and (c) $C = 5$. Note that in (a), the first line does not go on indefinitely, but ends as shown.

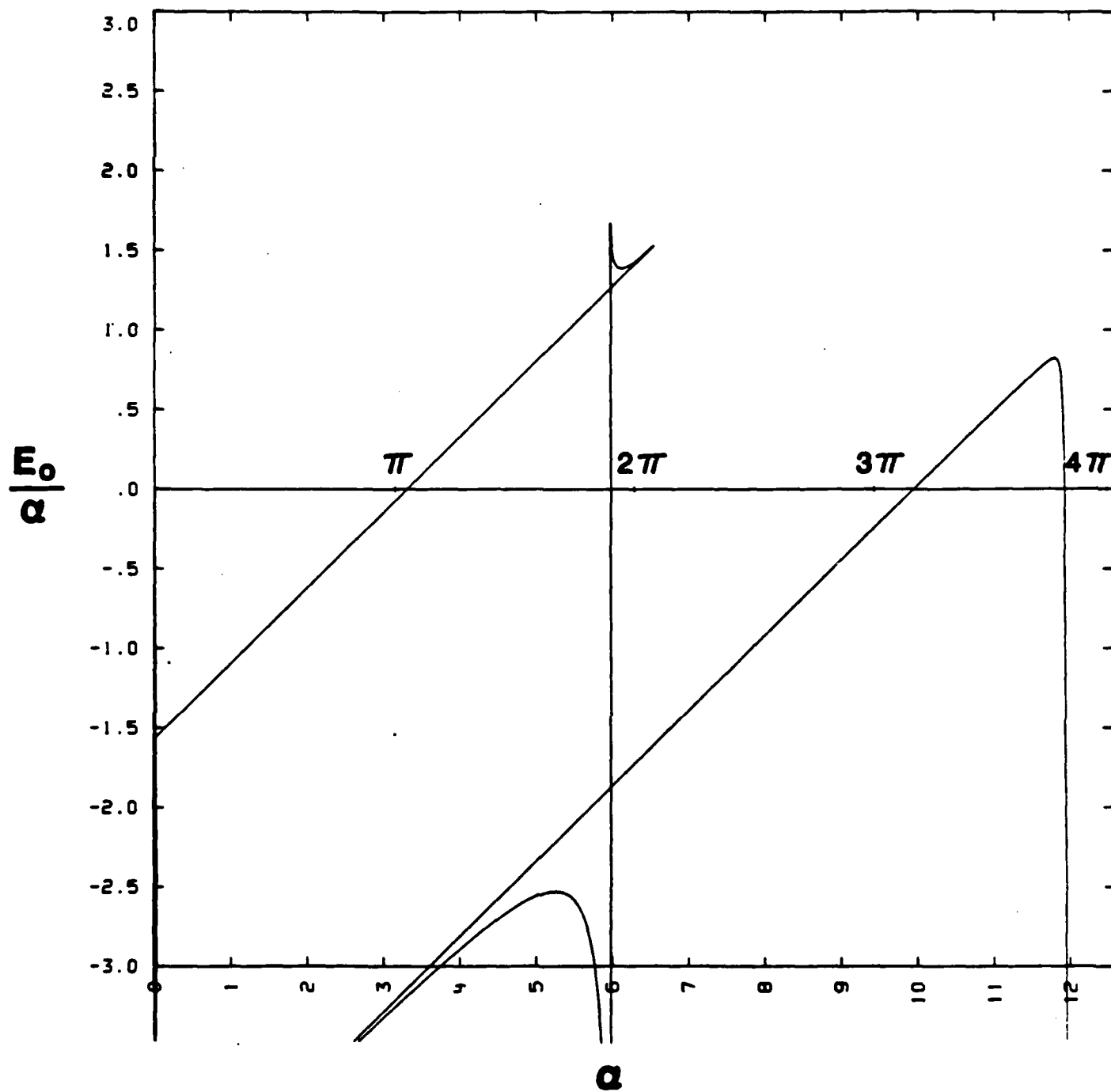

Fig. 4. Non-uniform equilibria for $C = 20$ without requirement that potential be a single-valued function of position

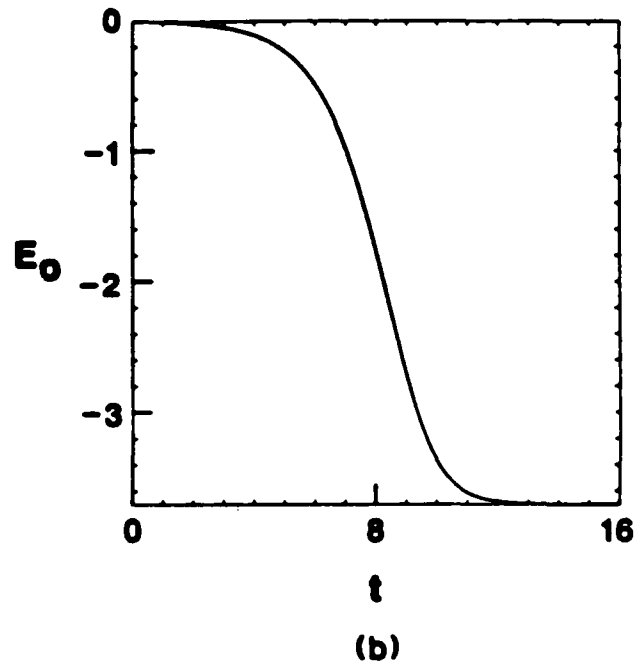
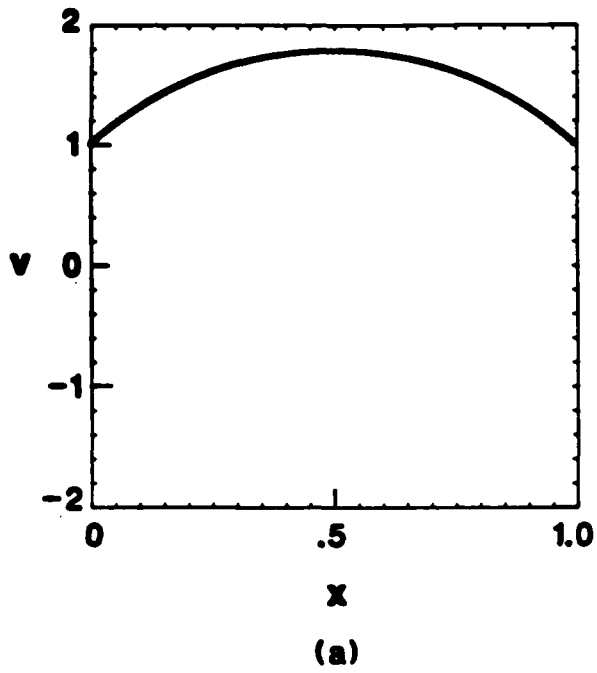

Fig. 5. Phase space at end of run and history of E_0 for short circuit case with $\alpha = 3\pi/2$. (Phase space plot is actually comprised of many particles, and not a single curve, as it appears.)

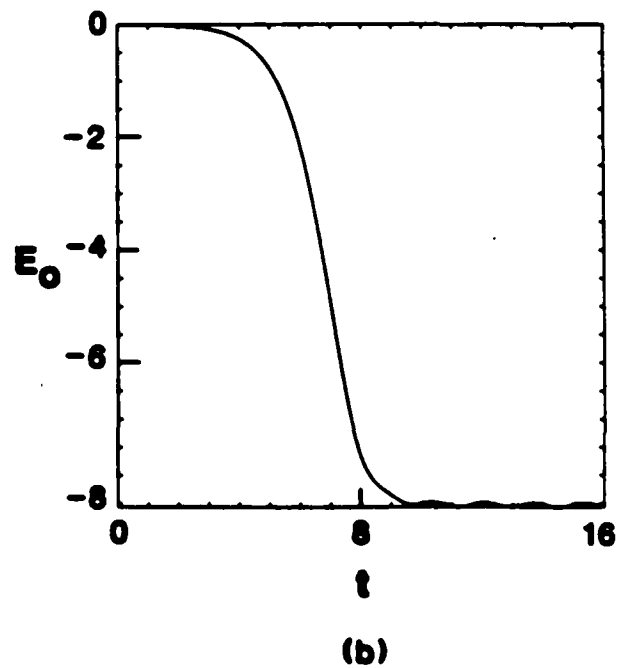
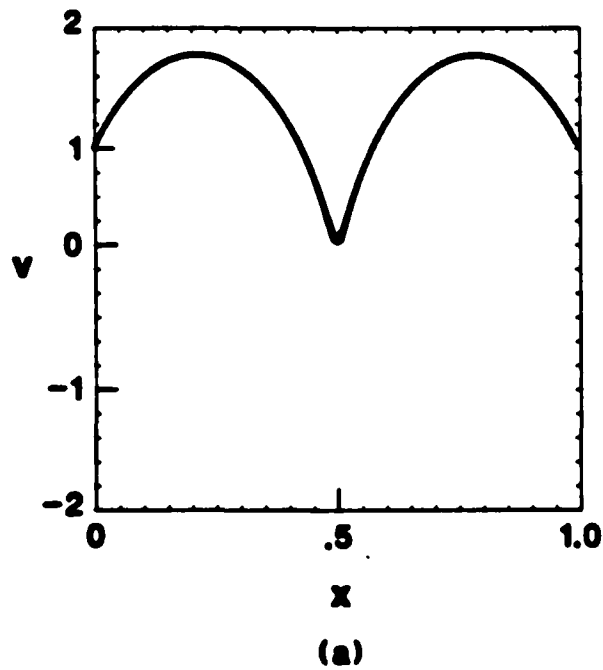
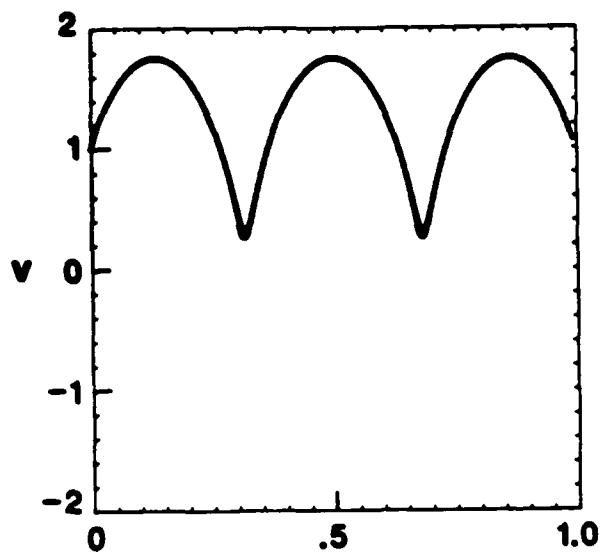
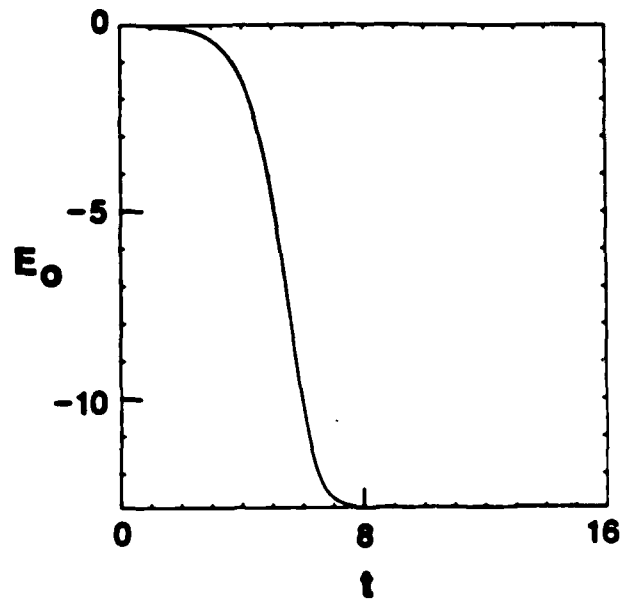

Fig. 6. Phase space at end of run and history of E_0 for short circuit case with $\alpha = 7\pi/2$



(a)



(b)

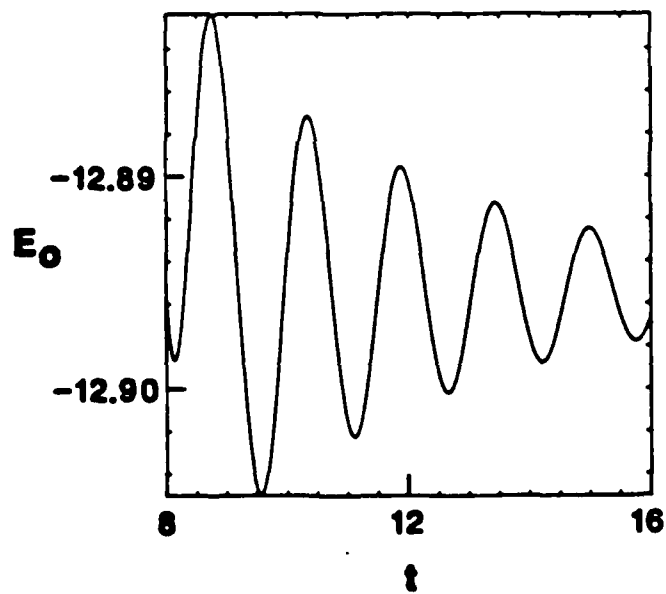

(c)

Fig. 7. Phase space at end of run and history of E_0 for short circuit case with $\alpha = 11\pi/2$. (Figure (c) is a blow-up of the last half of fig. (b).)

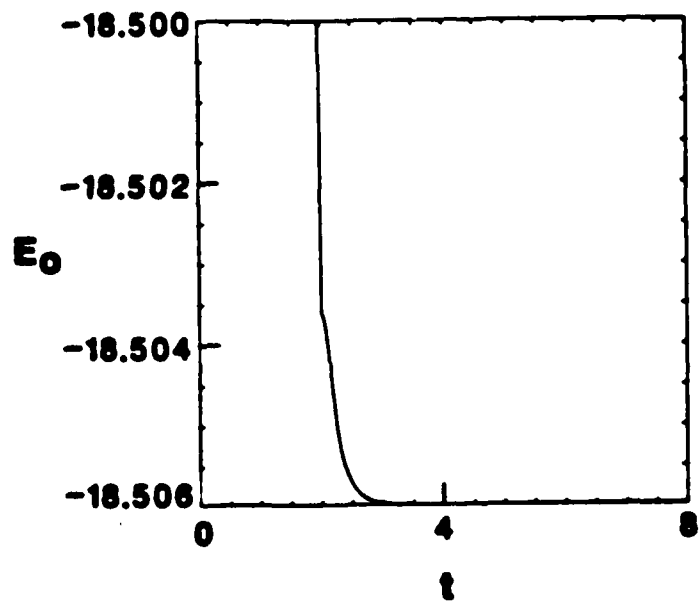
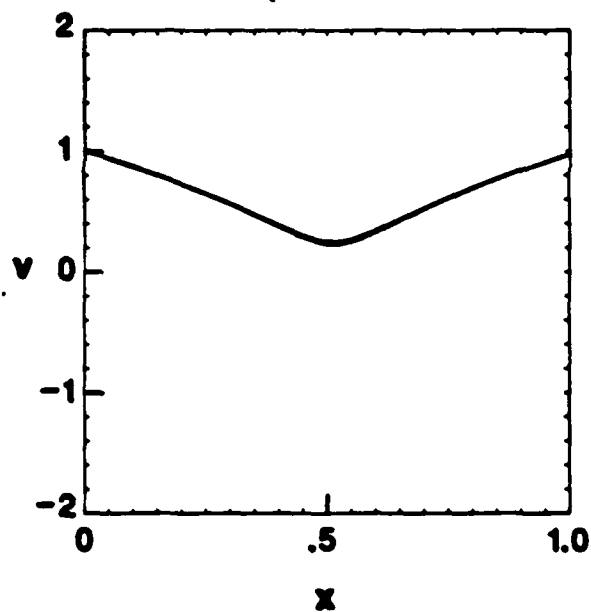
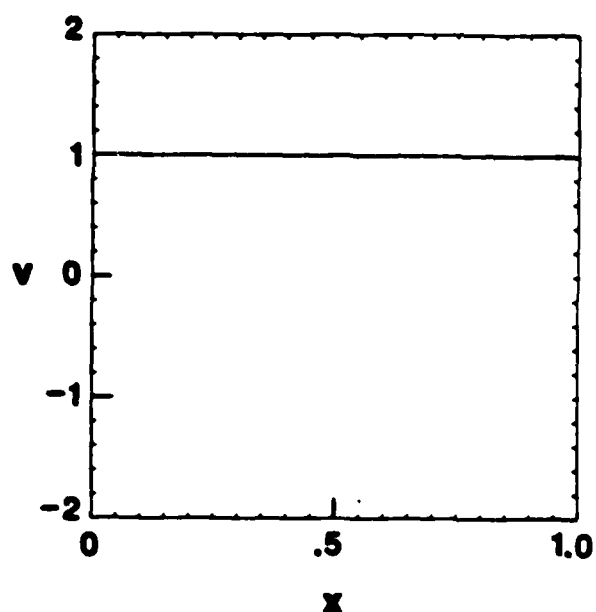

Fig. 8. History of E_0 for short circuit case with $\alpha = 5\pi/2$ ($n = 1$ branch).



(a)



(b)

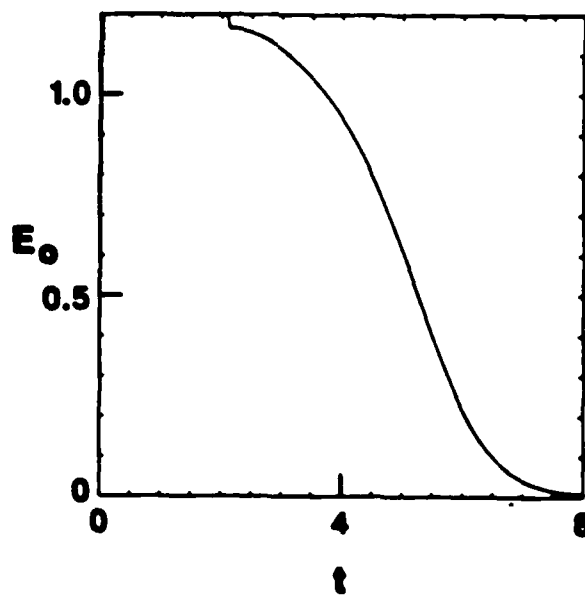

(c)

Fig. 9. Early and late phase space plots (a) and (b) with history of E_0 (c) for short circuit case with an initial $E_0 = -1.2$

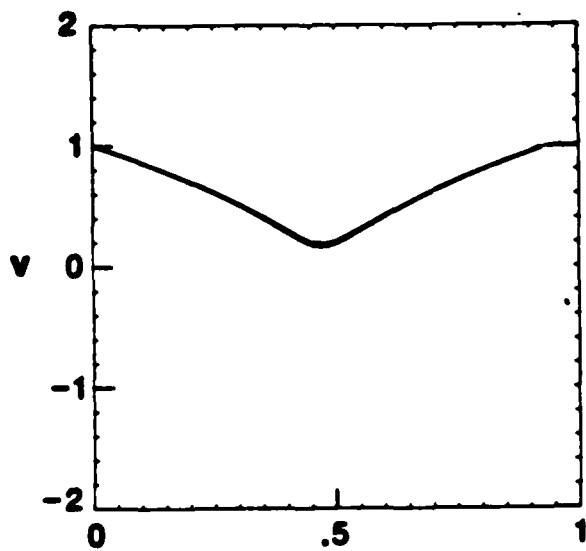

(a)

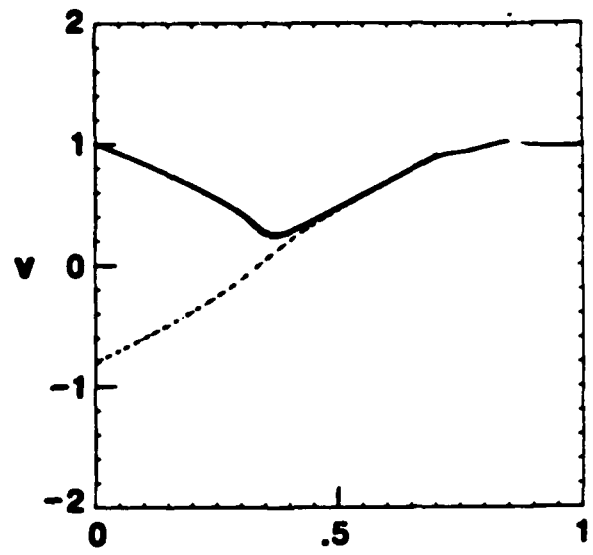

(b)

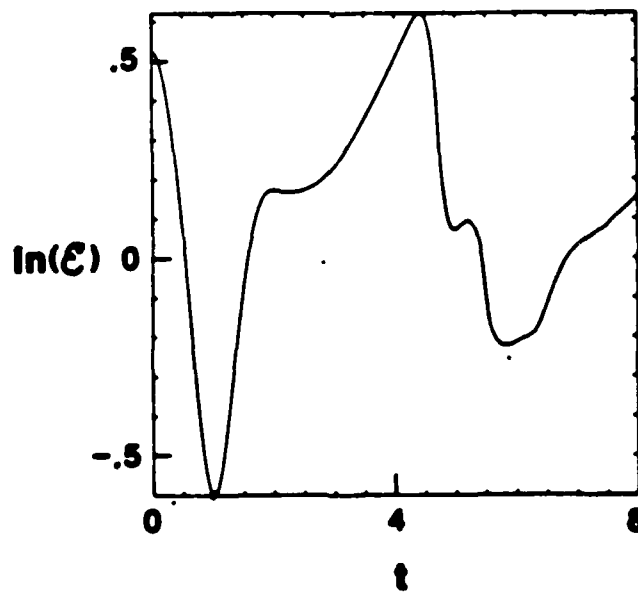

(c)

Fig. 10. Early and late phase space plots (a) and (b) with history of the natural log of the electrostatic energy \mathcal{E} (c) for short circuit case with an initial $E_0 = -1.3$

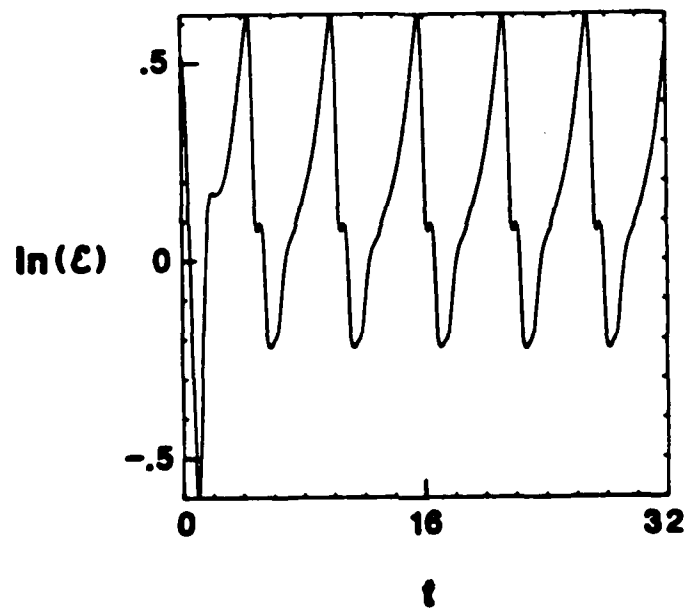
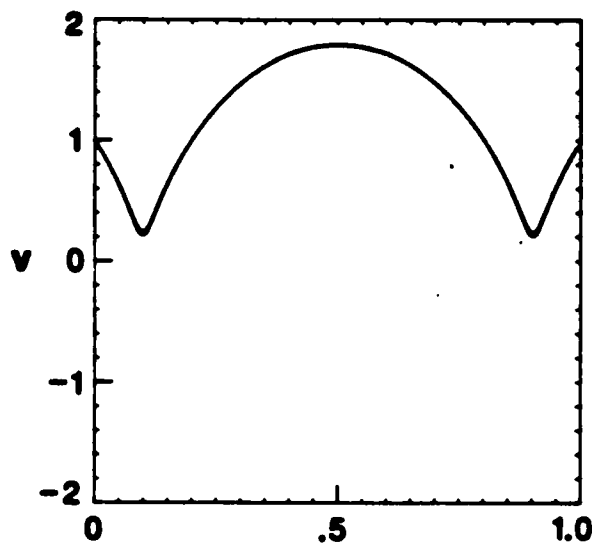
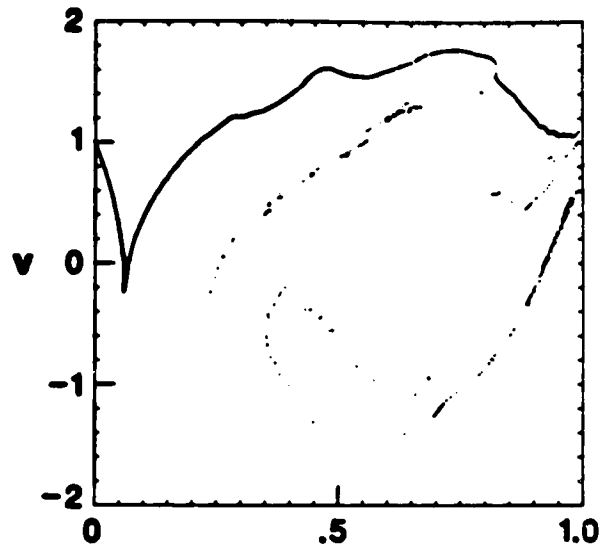

Fig. 11. Virtual cathode oscillations in stable region with initial $E_0 = -1.3$. \mathcal{E} represents the total electrostatic energy.



(a)



(b)

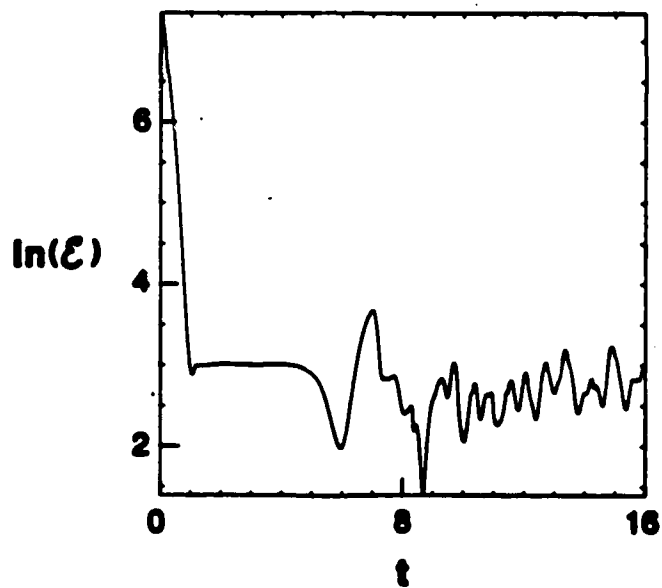

(c)

Fig. 12. Early and late phase space plots and history of E_0 for unstable equilibrium in short circuit case with $\alpha = 5\pi/2$. Again, \mathcal{E} represents the total electrostatic energy.

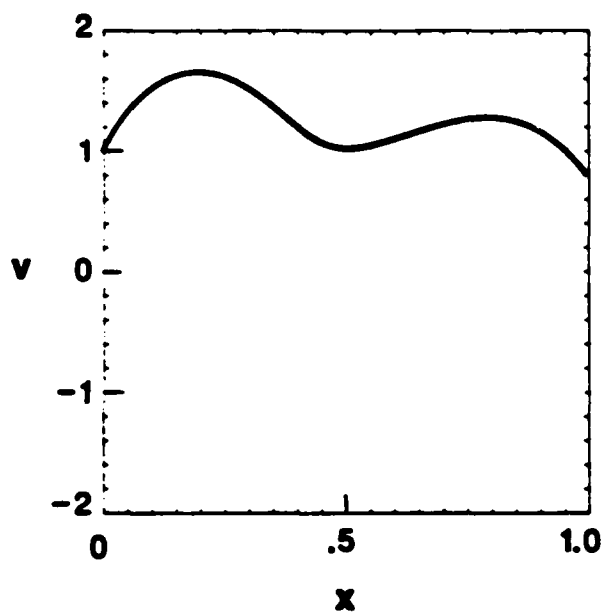

(a)

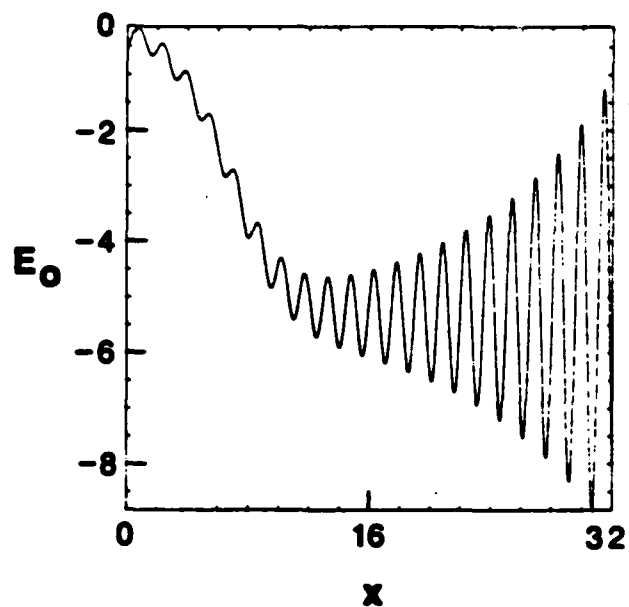

(b)

Fig. 13. Phase space plot and history of E_0 for almost-stable mode at $\alpha = 7\pi/2$ with $C = 20$

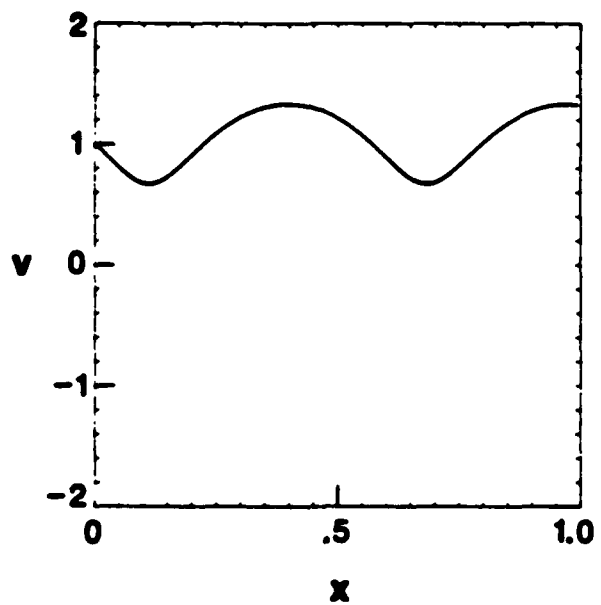

(a)

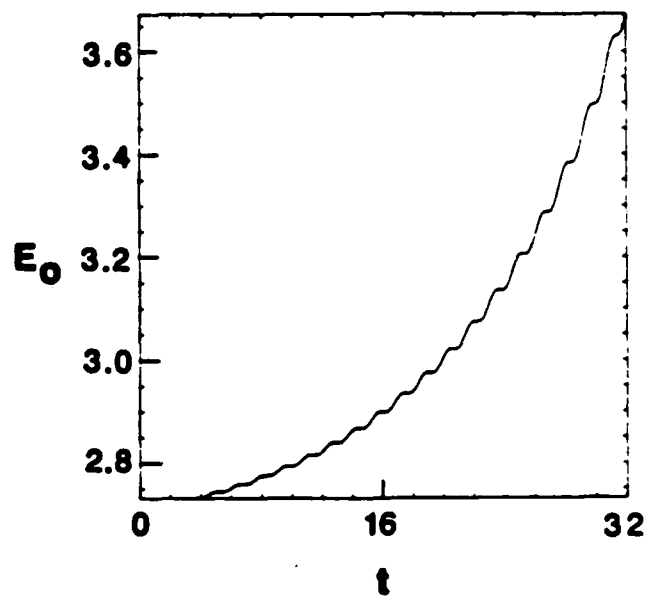

(b)

Fig. 14. Phase space plot and history of E_0 for almost stable mode at $\alpha = 7\pi/2$ with $C = 10$ and initial E_0 near equilibrium value

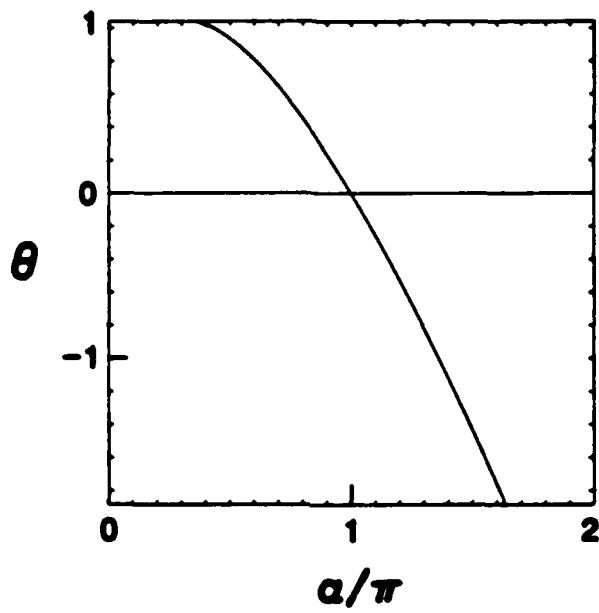
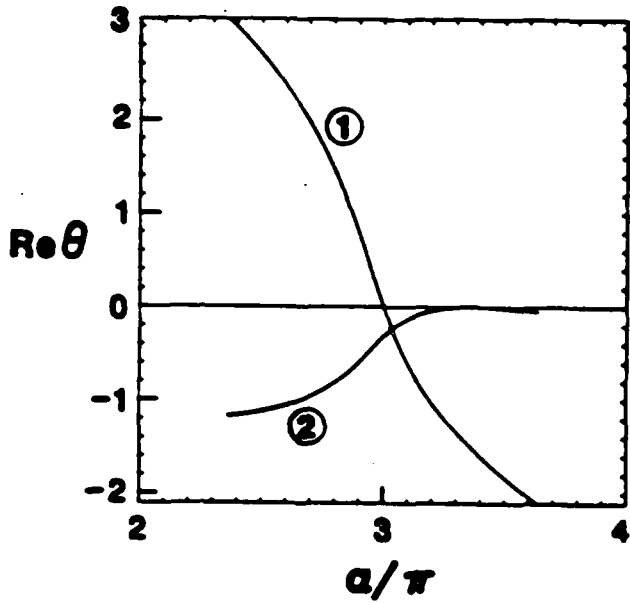
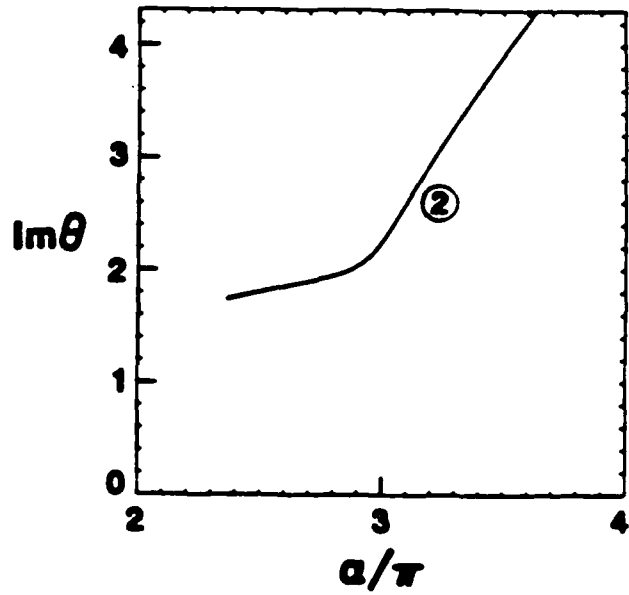

Fig. 15. Dispersion curve for dominant mode of non-uniform equilibrium in short circuit case for $0 < \alpha < 2\pi$ ($Im \theta$ is zero for this mode)



(a)



(b)

Fig. 16. Dispersion curves for dominant modes of non-uniform equilibrium in short circuit case for $2\pi < \alpha < 4\pi$. The mode which is dominant for $\alpha/\pi < 3$ is purely growing.

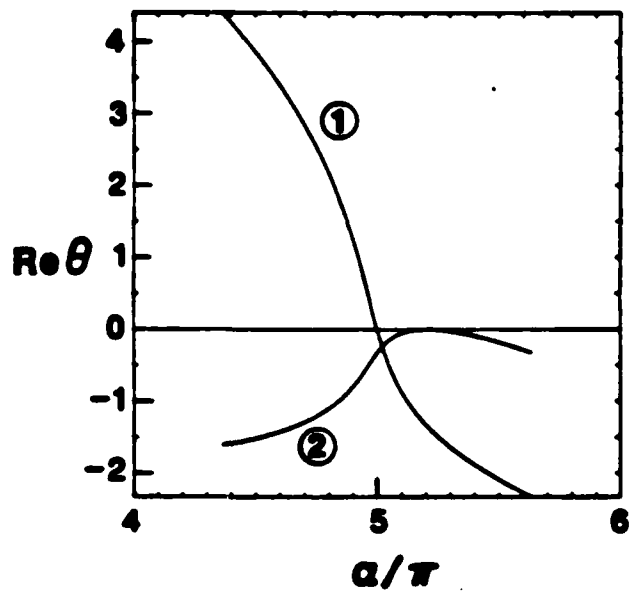

(a)

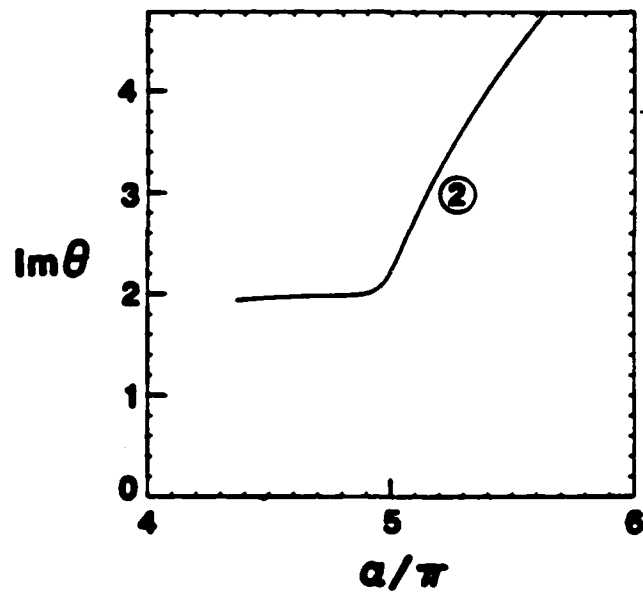

(b)

Fig. 17. Dispersion curves for dominant modes of non-uniform equilibrium in short circuit case for $4\pi < a < 6\pi$. The mode which is dominant for $a/\pi < 5$ is purely growing.

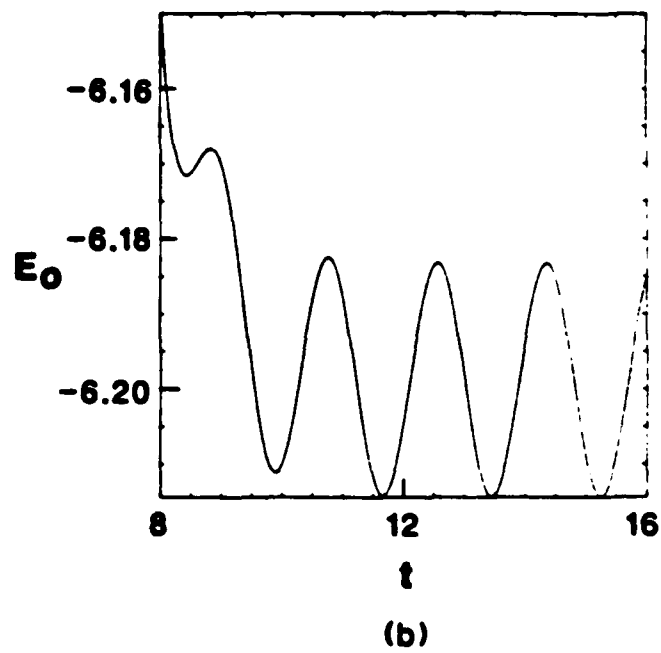
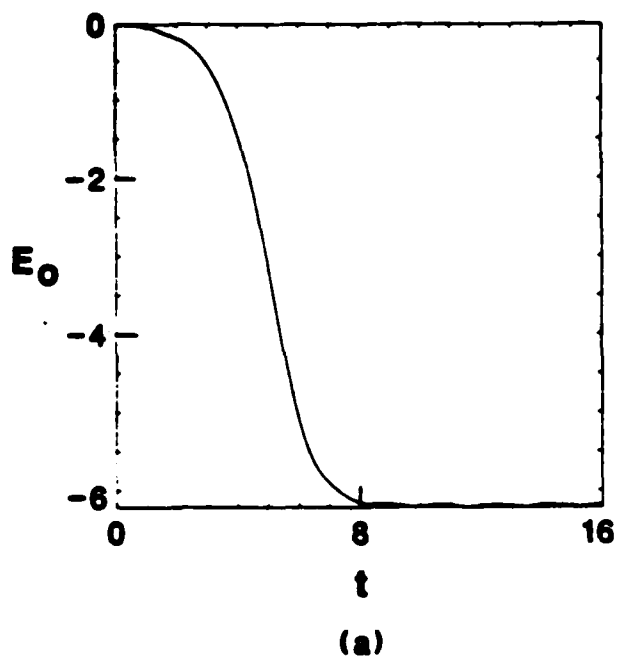

Fig. 18. History of E_0 for marginally stable equilibrium in short circuit case at $\alpha = 3 - 3/8 \pi$. Figure (b) is a blow-up of the last half of fig. (a).

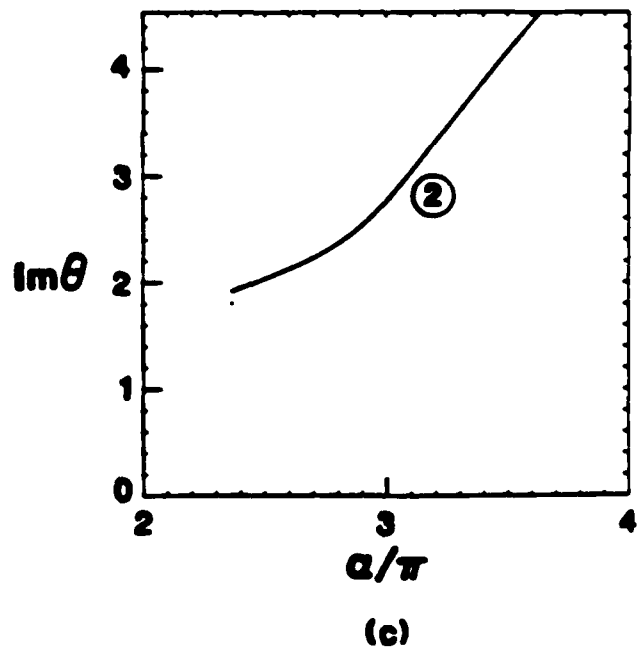
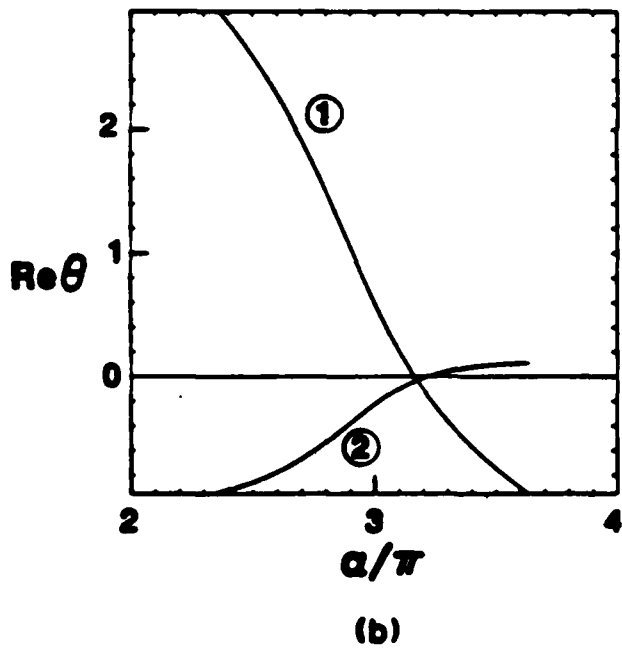
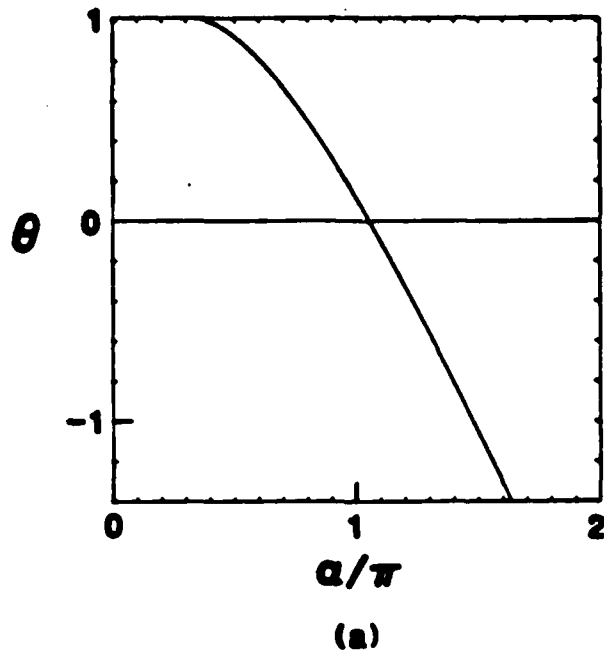
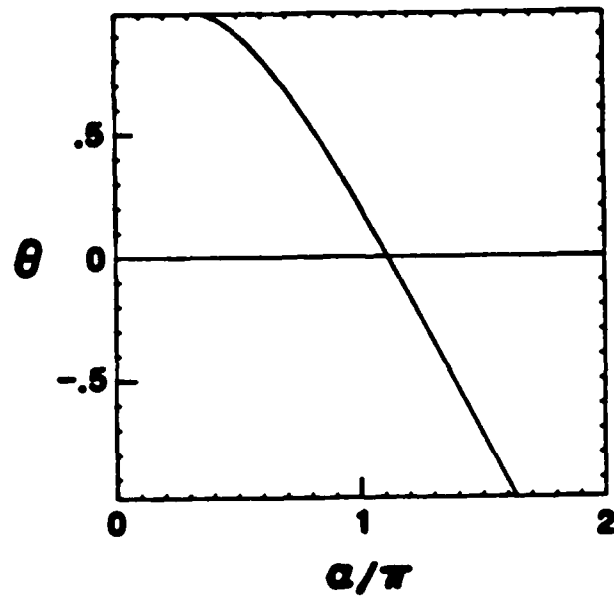
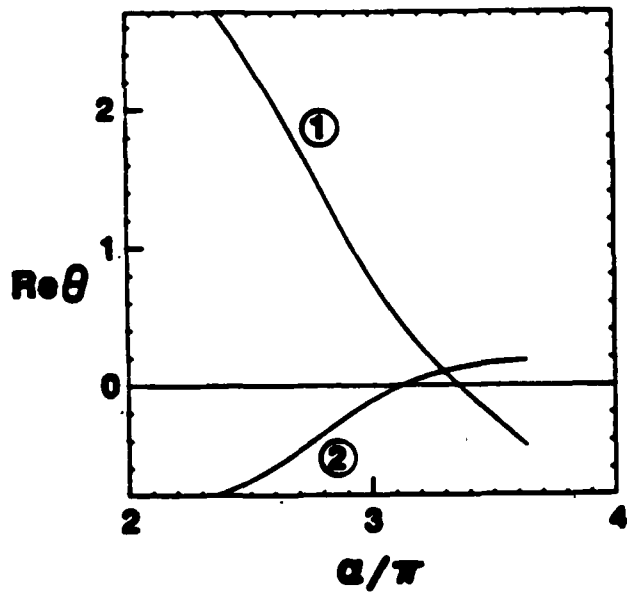

Fig. 19. Dispersion curves for dominant modes of non-uniform equilibrium for $C = 20$. Mode which is dominant for $2 < a/\pi < 3$ is purely growing.



(a)



(b)

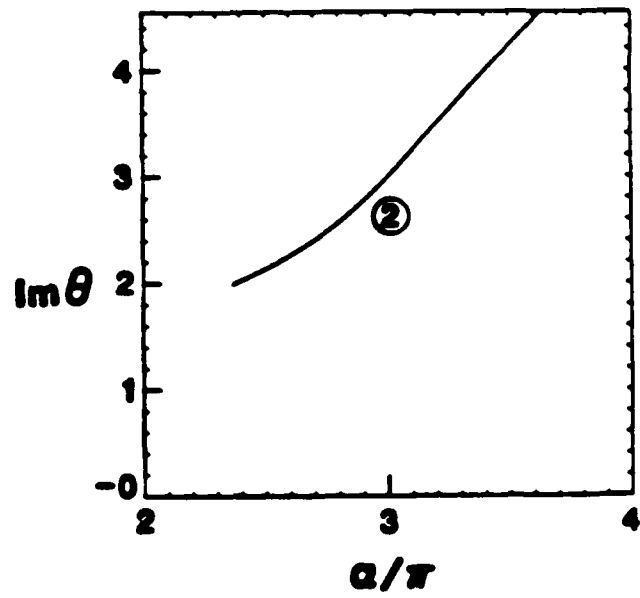

(c)

Fig. 20. Dispersion curves for dominant modes of non-uniform equilibrium for $C = 10$. Mode which is dominant for $2 < a/\pi < 3$ is purely growing.

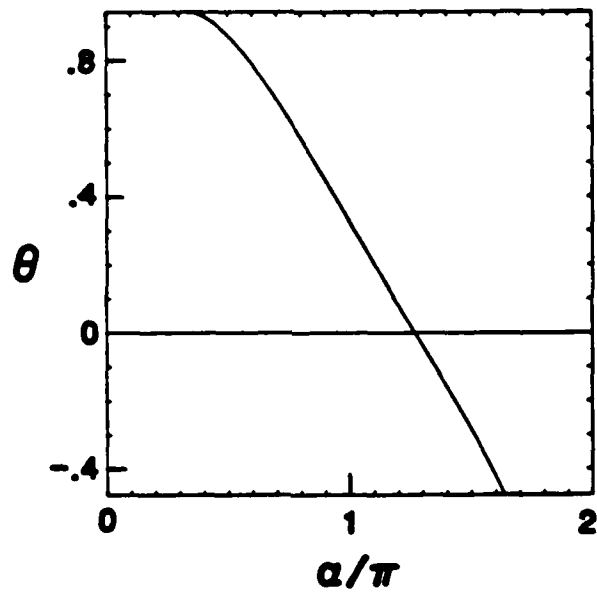
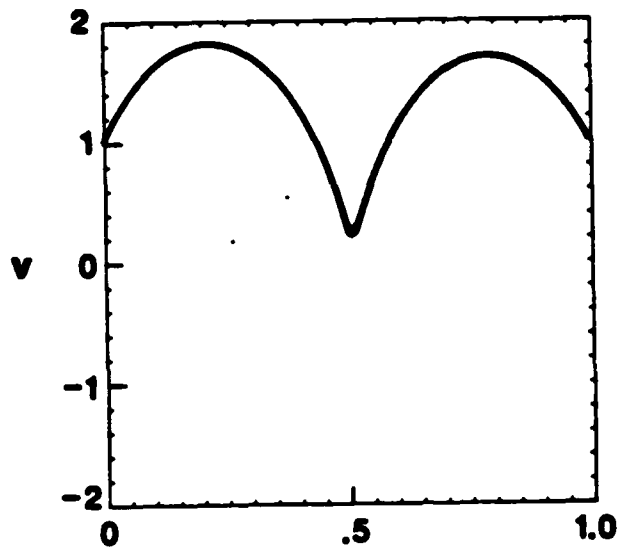
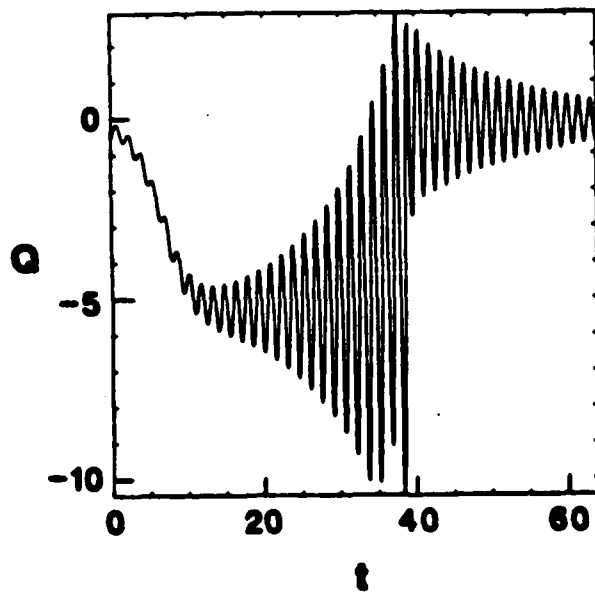

Fig. 21. Dispersion curve for dominant mode of non-uniform equilibrium for $C = 5$



(a)



(b)

Fig. 22. Phase space at $t = 64$ and history of charge on external capacitor Q . Between $t = 35$ and $t = 40$, electrons are turned back to the injection plane, producing a state which cannot return to the uniform equilibrium. Note there are two trapped electrons in the first half of the system.

END
FILMED
FEB. 1988
DTIC