

Unclassified

AD-A188305

SECURITY CLASSIFICATION OF THIS PAGE

Form Approved
OMB No 0704-0188
Exp Date Jun 30, 1986

REPORT DOCUMENTATION PAGE

1a REPORT SECURITY CLASSIFICATION Unclassified		1b RESTRICTIVE MARKINGS	
2a SECURITY CLASSIFICATION AUTHORITY		3 DISTRIBUTION / AVAILABILITY OF REPORT Approved for public release; distribution unlimited.	
2b DECLASSIFICATION / DOWNGRADING SCHEDULE		4 MONITORING ORGANIZATION REPORT NUMBER(S)	
4 PERFORMING ORGANIZATION REPORT NUMBER(S) Technical Report ITL-87-7		5 MONITORING ORGANIZATION REPORT NUMBER(S)	
6a. NAME OF PERFORMING ORGANIZATION See reverse	6b OFFICE SYMBOL (if applicable) See reverse	7a NAME OF MONITORING ORGANIZATION	
6c. ADDRESS (City, State, and ZIP Code) US Army Engineer Waterways Experiment Station PO Box 631 Vicksburg, MS 39180-0631		7b ADDRESS (City, State, and ZIP Code)	
8a. NAME OF FUNDING / SPONSORING ORGANIZATION See reverse	8b OFFICE SYMBOL (if applicable) CELMV-ED-G	9 PROCUREMENT INSTRUMENT IDENTIFICATION NUMBER	
8c. ADDRESS (City, State, and ZIP Code) PO Box 80 Vicksburg, MS 39180-0080		10 SOURCE OF FUNDING NUMBERS	
		PROGRAM ELEMENT NO	PROJECT NO
		TASK NO	WORK UNIT ACCESSION NO
11 TITLE (Include Security Classification) Comparison of Axial Capacity of Vibratory-Driven Piles to Impact-Driven Piles			
12 PERSONAL AUTHOR(S) Mosher, Reed L.			
13a TYPE OF REPORT Final report	13b TIME COVERED FROM Oct 84 to Sep 87	14 DATE OF REPORT (Year, Month, Day) September 1987	15 PAGE COUNT 58
16 SUPPLEMENTARY NOTATION Available from National Technical Information Service, 5285 Port Royal Road, Springfield, VA 22161.			
17 COSATI CODES		18 SUBJECT TERMS (Continue on reverse if necessary and identify by block number)	
FIELD	GROUP	Lock and Dam No. 1 (Red River) (LC) Piling (Civil engineering)	
		Locks (Hydraulic engineering)	
		Pile Drivers (LC)	
19 ABSTRACT (Continue on reverse if necessary and identify by block number) <p>This technical report documents the findings of an investigation into the effects on the axial capacity of piles driven by vibratory pile-driving hammers. The investigation stems from the concern that foundation engineers in the Lower Mississippi Valley Division of the US Army Corps of Engineers had over the unexpected low capacities found during the pile test at Red River Lock and Dam No. 1. While driving piles with a vibratory hammer increases productivity up to 10 to 20 times over the use of an impact hammer, there is a significant reduction in the axial capacity of the piles driven with a vibratory hammer. The study revealed that this reduction was a result of a loss in the load carried by the tip. The report documents a number of pile testing programs that were performed to make direct comparison between vibratory-driven piles and impact-driven piles.</p>			
20 DISTRIBUTION / AVAILABILITY OF ABSTRACT <input checked="" type="checkbox"/> UNCLASSIFIED/UNLIMITED <input type="checkbox"/> SAME AS RPT <input type="checkbox"/> DTIC USERS		21 ABSTRACT SECURITY CLASSIFICATION Unclassified	
22a NAME OF RESPONSIBLE INDIVIDUAL		22b TELEPHONE (include Area Code)	22c OFFICE SYMBOL

Unclassified

SECURITY CLASSIFICATION OF THIS PAGE

6a. & 6b. NAME OF PERFORMING ORGANIZATION AND OFFICE SYMBOL (Continued).

Engineering Application Office	CEWES-KA-E
Information Technology Laboratory	CEWES-IM-R

8a. NAME OF FUNDING/SPONSORING ORGANIZATION (Continued).

US Army Engineer Division
Lower Mississippi Valley

Unclassified

SECURITY CLASSIFICATION OF THIS PAGE

PREFACE

This report investigates the effect of uses of vibratory pile-driving hammers on axial capacity of piles. This study concentrated on field tests that were conducted for direct comparison between vibratory-driven piles and impact-driven piles. The results show that vibratory-driven piles generally have a significantly lower ultimate axial capacity than similar impact-driven piles.

The work was conducted during the period 1984 through 1987 as part of the assistance provided by the Engineering Application Office (EAO), formerly Engineering Application Group, Scientific and Engineering Application Division (SEAD), Automation Technology Center (ATC), US Army Engineer Waterways Experiment Station (WES), to the US Army Engineer Division, Lower Mississippi Valley (LMVD). Work on the project was coordinated with LMVD with Messrs. Frank J. Weaver and James A. Young, Geology, Soils, and Materials Branch, Engineering Division, LMVD. Mr. Young acted as technical monitor for the project.

The work was accomplished in the Information Technology Laboratory (ITL) by Mr. Reed L. Mosher, EAO, with assistance from Virginia Noddin, EAO, under the general supervision of Mr. Paul K. Senter, Acting Chief, Information Research Division (IRD), ITL, formerly Chief, SEAD, and Dr. N. Radhakrishnan, Acting Chief, ITL, former Chief, ATC, WES. Final editing for the publication of this report was done by Mrs. Gilda Miller, Information Products Division, WES.

COL Allen F. Grum, USA, was the previous Director of WES. COL Dwayne G. Lee, CE, is the present Commander and Director. Dr. Robert W. Whalin is Technical Director.



Accession	
NTIS	CS&M <input checked="" type="checkbox"/>
DTIC	TPS <input type="checkbox"/>
DAIR	CS&M <input type="checkbox"/>
JAN 1988	
By	
Date	
Approved	
Date	
A-1	

CONTENTS

	<u>Page</u>
PREFACE.....	1
CONVERSION FACTORS, NON-SI TO SI (METRIC) UNITS OF MEASUREMENT.....	3
PART I: INTRODUCTION.....	4
Background.....	4
Purpose.....	4
Scope.....	5
PART II: PILE DRIVERS.....	6
Introduction.....	6
Impact Driving.....	6
Type of Impact Hammers.....	6
Vibratory Driving.....	8
PART III: FIELD PILE TESTS.....	10
Arkansas River Lock and Dam No. 4.....	10
Arkansas River Lock and Dam No. 3.....	15
Crane Rail Tracks (Mazurkiewicz 1975).....	21
Geochemical Building, Harvard University and Wall No. 7, I-95, Providence, Rhode Island.....	26
PART IV: SUMMARY AND CONCLUSIONS.....	31
Summary of Field Tests.....	31
Conclusions.....	35
REFERENCES.....	36
APPENDIX A: PILE TESTS, ARKANSAS RIVER LOCK AND DAM NO. 4.....	A1
APPENDIX B: PILE TESTS, ARKANSAS RIVER LOCK AND DAM NO. 3.....	B1

CONVERSION FACTORS, NON-SI TO SI (METRIC)
UNITS OF MEASUREMENT

Non-SI units of measurement used in this report can be converted to SI
(metric) units as follows:

<u>Multiply</u>	<u>By</u>	<u>To Obtain</u>
degrees (angle)	0.01745329	radians
feet	0.3048000	metres
foot/pound (force)	1.355818	metre-newtons
inches	2.54	centimetres
miles	1.609347	kilometres
pounds (force)	4.448222	newtons
tons (force)	8.896444	kilonewtons

COMPARISON OF AXIAL CAPACITY OF VIBRATORY-DRIVEN
PILES TO IMPACT-DRIVEN PILES

PART I: INTRODUCTION

Background

1. In recent years the use of vibratory pile-driving hammers has gained popularity with contractors because of the increased productivity realized with their use. The time required to drive a 100-ft* pile with a vibratory hammer is approximately 1 to 2 min as compared to 10 to 20 min with an impact hammer. A pile foundation for one of the US Army Corps of Engineers navigational structures may require as many as 5,000 to 8,000 piles to be driven. An increase in productivity of 10 to 20 times is very attractive and profitable to contractors.

2. Foundation engineers have been concerned about the effect on the axial capacity of piles driven by vibratory hammers. The installation of a pile inescapably results in altering the stresses in the soil surrounding the pile. Studies by Meyerhof (1959), Robinsky and Morrison (1964), and Ellison (1969) have revealed that impact driving in granular soils causes compaction of the soil in the vicinity of the pile, and the stress levels are consequently increased. Less is known about the changes that the soil undergoes in the vicinity of a vibratory-driven pile.

Purpose

3. During the construction of Lock and Dam No. 1 on the Red River, a pile testing program was undertaken to verify the pile design for the dam. The piles at the site were driven with a vibratory hammer. The piles tested were H-piles with lengths between 55 and 70 ft. The capacities of the piles tested were 70 percent less than the expected values. As a result of these pile tests, the Lower Mississippi Valley Division (LMVD) has become interested

* A table of factors for converting non-SI units of measurement to SI (metric) units is presented on page 3.

in whether or not the reduced capacity was due to the driving of the piles with a vibratory hammer. To investigate these concerns, LMVD instituted this study.

Scope

4. The primary objective of this report is to investigate the effects of vibratory driving on the axial pile capacity by examining available pile test data. The pile load test has long been known as the only true measure of axial capacity for a given site. A load test permits the direct measurement of pile capacity under the actual construction and soil conditions that prevail at the site. This study has concentrated on test programs at sites where tests were performed on piles driven by both vibratory and impact hammers.

5. In Part II, a brief history and description of impact and vibratory pile-driving hammers is given. The site conditions, the pile descriptions, and the results of the tests investigated in this study are presented in Part III. The results of the investigation are summarized and the conclusions are presented in Part IV.

PART II: PILE DRIVERS

Introduction

6. Piles are often classified by the methods of installation. Current construction practices for installing piles may be divided into four basic categories: driven, bored and cast-in-place, driven and cast-in-place, and jetted. Jetted and bored piles, seldom used in sand, are not discussed in this report.

7. The driving of piles is one of the most common methods of installing a pile and can be characterized as the operation of forcing the pile into the ground by applying a dynamic load at the pile head. The driving of piles is well suited for the installation of small displacement piles in loose to medium-dense granular soils. Pile driving can be categorized by the method used to develop the dynamic load that forces the pile into the ground. The two most common methods for driving piles are impact and vibratory driving.

Impact Driving

8. The oldest and most common method of pile driving is impact driving. Impact hammers or drop hammers originated with the Romans who used a stone block hoisted by rope over a pulley guide and then dropped. The block was guided to its destination by vertical poles. Today impact hammers operate between a pair of vertical guides called leads suspended from the boom of a crane. The leads have rails similar to the Romans' vertical poles which guide the hammer during its descent. The leads are linked to the head of the crane jib and to control their verticality or batter the leads are connected to the base of the crane by a horizontal member called a spotter.

Types of Impact Hammers

9. Under the classification impact driving there are four basic types of pile-driving hammers:

- a. Drop hammer
- b. Single-action steam/air hammer

- c. Double-action steam/air hammer
- d. Diesel hammer (single and double action)

Drop hammer

10. The drop hammer is the most simple hammer, consisting of a ram made of cast steel that is raised by a cable over a pulley guide at the top of a framework. The cable is attached to a winch or a gear shaft and has a tripping mechanism to release the ram once it reaches the top of the guide rails. Once released, the ram free falls along the guide rails and strikes the head of the pile, thus driving it into the ground. Drop hammers are extremely slow and are used only on small jobs where the cost of other equipment is not warranted.

Single-action steam/air hammer

11. The single-action steam/air hammer is a relatively long-stroke machine which uses steam or compressed air to lift the ram. The steam or air is then released to allow the ram to drop on the pile head. The energy for this type of hammer is simply the weight of the ram times the height of the fall. The mass of the rams for these types of hammers range from 3,000 to 175,000 lb with energy ratings of 7,260 to 868,000 ft-lb per blow. The maximum height of the drop of the ram is usually about 4.5 ft and the hammer can be operated at rates up to 60 strokes per minute.

Double-action steam/air hammer

12. The double-action steam/air hammer makes use of steam or compressed air, both to lift the ram and to accelerate it downward. The blows are more rapid, but the weight of the ram is considerably less as compared to the single-action hammer of similar energy. The mass of the ram ranges from 200 to 40,000 lb with energy ratings from 1,200 to 113,000 ft-lb per blow and the hammers have stroke rates of 100 to 300 blows per minute. The hammers are light, self contained, and especially well suited for heavy piling such as H-piles, pipe piles, and timber piles.

Diesel hammer

13. The principle behind the diesel hammer is that as the falling ram compresses air in the cylinder, diesel fuel is injected into the cylinder and this is atomized by the impact of the ram on the concave base of the cylinder. The impact ignites the fuel and the resulting explosion contributes an additional "kick" to the head of the pile, which is already receiving a blow from the ram. Thus, the blow is sustained and imparts energy over a longer period

than the simple blow of a single-action steam/air hammer. The ram rebounds after the explosion and scavenges the burnt gases from the chamber. The mass of the ram ranges from 500 to 33,000 lb with energy ratings of 800 to 286,000 ft-lb per blow and has stroke rates of 40 to 60 blows per minute.

Vibratory Driving

14. The first low-frequency vibratory pile driver was used in the construction of a hydroelectric project at Gorky, in the Soviet Union in 1957 (Barkan 1957). The vibratory hammer, BT-5 type, was used to drive 3,700 sheet piles to depths ranging from 28 to 40 ft into a saturated sand in about 2 to 3 min per pile. Comparisons between the vibratory hammer and the pneumatic hammer indicated that the vibratory hammer drove about 60 percent more sheet piles than the pneumatic hammer in an 8-hr shift and required 25 percent less power to operate.

Resonant hammers

15. A second type of vibratory hammer known as the resonant vibrator or the sonic pile driver was first introduced by Albert G. Bodine, Jr., of California. This type of hammer operates at high frequencies causing the pile to oscillate near its own half-wave frequency. In 1961, the C. L. Guild Co. of Providence, R. I., gave a spectacular demonstration of this hammer. In this demonstration, the Bodine hammer drove a closed-end pipe pile 71 ft, while an adjacent steam hammer drove an identical pile just 3 in. in the same time period (Engineering News Record (ENR) 1961).

Vibratory hammers

16. Vibrators consist of a pair of axles geared together to rotate at equal speeds in opposite directions. The axles carry eccentric weights and are driven by an electric motor. A hydraulic clamp at the base of the vibrator is used to attach the hammer to the pile head. The principle on which this type of hammer works is that when the counter-rotating eccentric masses are phased together and driven at the same speed, the horizontal components of the resulting rotational force cancel, while the vertical components combine. The vertical components are cyclic and they are directed first upward and then downward. The pile moves downward due to the weight of the hammer and the pile.

17. Vibratory hammers can be classified into low-frequency and

high-frequency (resonant) vibrators, according to the range of their operating frequency. Low-frequency vibratory hammers operate at frequencies in the range of 5 to 50 Hz. High-frequency vibratory hammers such as the Bodine hammer operate at frequencies in the range of 40 to 140 Hz.

18. Vibratory hammers operate most effectively when driving small displacement piles such as H-sections or open-end pipe piles in loose to medium-dense granular soils. Vibratory hammers have an advantage over impact hammers in that the noise and shock wave associated with blows delivered by the ram are eliminated. They also cause less damage to the piles and have a significantly faster rate of penetration in favorable soil conditions such as sands.

PART III: FIELD PILE TESTS

19. The five testing programs that directly compared impact- and vibratory-driven piles are:

- a. Arkansas River Lock and Dam No. 4
- b. Arkansas River Lock and Dam No. 3
- c. Crane rail tracks
- d. Geochemical Building, Harvard University
- e. Wall No. 7, I-95, Providence, Rhode Island

Arkansas River Lock and Dam No. 4

20. The pile testing program for Lock and Dam No. 4 was instituted as the primary source of information for the design and construction of the four locks and dams along the lower Arkansas River Valley. In view of the magnitude of the projects and the lack of factual information regarding the driving and axial and lateral load capacities of piles in the lower Arkansas River Valley, a comprehensive pile testing program was conducted by the US Army Engineer District, Little Rock. The purpose of the tests were to develop criteria for the design and construction of pile foundations for the future locks and dams. The general objectives of the pile investigation were to establish criteria for the design and construction of axially loaded piles. Parameters included were the size and penetration of various types of piles for both compression and tension, the type and size of pile-driving hammers required for economical installation, and the design and construction of laterally loaded piles including the effects of batter and cyclic loading. Compression test results are shown for 12 different piles in Appendix A (Fruco and Associates, 1964).

Site description

21. Soil conditions in the lower Arkansas River Valley are typical of an alluvial pastoral zone. In general, they consist of alluvial deposits of loose surface silts, sandy silts, and clays of variable thickness underlain by a zone of medium to dense silty sand with a thickness ranging from 70 to 150 ft. This all overlies a stratum of deeply bedded Tertiary clays.

22. The test site was located on the east bank of the Arkansas River about 20 miles downstream from Pine Bluff and 9 miles upstream from the future

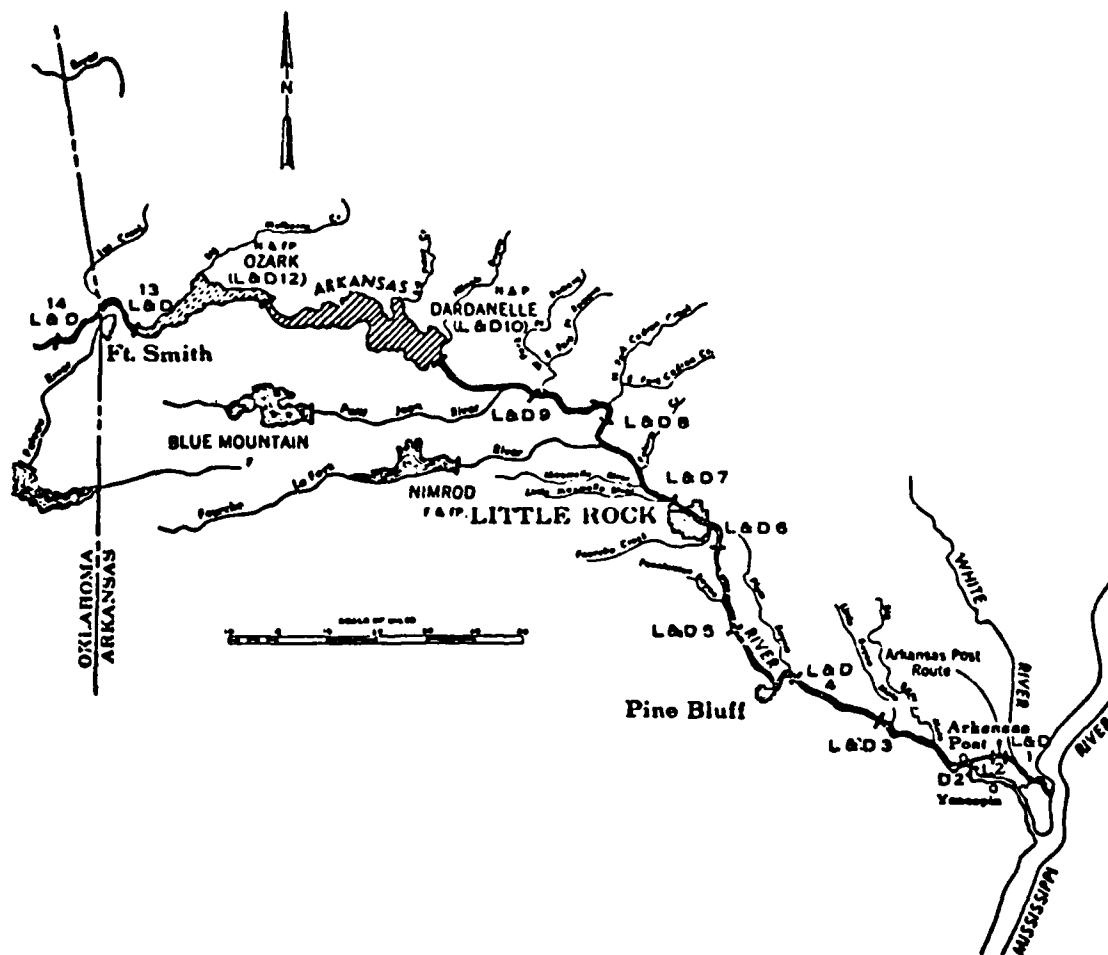

Figure 1. Arkansas River Navigation Project

site of Lock and Dam No. 3 (Figure 1). The soil conditions at the pile testing site were determined by exploratory borings and laboratory tests made in connection with the foundation investigation for Lock and Dam No. 4, and further explorations were made specifically for the pile testing program. These explorations indicated that three major soil strata exist at the test site: a surface blanket of silts and clays which extends about 15 ft below the ground surface, a deep stratum of relatively dense, fine to medium sand which extends about 100 ft, and a basal stratum of Tertiary clay of undetermined thickness. Discontinuous thin seams of silt and clay were encountered in sand stratum at depths between 30 to 50 ft.

23. The test area was prepared by excavating approximately 20 ft of silty surface soils which exposed the underlying stratum of sand. Post-excavation standard penetration resistances increased with depth ranging from

20 to 40 blows per foot, with an average of about 27 blows per foot. The dry density of the sand ranged from 90 to 109 pcf, but showed no significant trend with depth. The ground-water level was held at 2 to 3 ft below the surface of the site. Figure 2 shows a generalized profile for the test site.

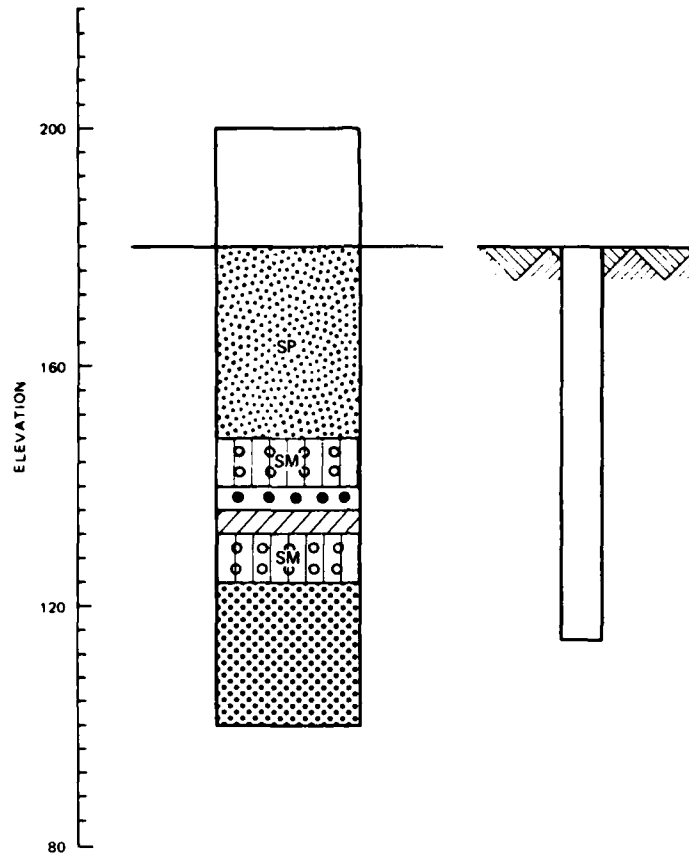

Figure 2. Generalized soil profile for Lock and Dam No. 4 pile test site

Description of testing program and results

24. The basic pile investigation included field driving and load tests on a variety of pile types. Tests were performed on square prestressed concrete piles, steel pipe piles, and steel H-piles that were driven with both a double-action steam and a Bodine sonic vibratory hammer. The field load tests included compression, tension, and lateral loading of single piles. Strain instruments were attached to steel piles to determine the distribution of stresses in the piles under compression, tension, and lateral loads.

25. Table 1 presents a summary of the axial load tests performed at the site. The table shows the type of pile tested, the penetration, the type of hammer used for installation, and the reported average failure loads for

compression and tension. The plots of the individual load tests are provided in Appendix A. Comparisons between impact and vibratory driven piles can be made with the 16-in. pipe piles, the H-piles, and the 16-in. concrete piles.

26. In Table 2, the distribution of the load being carried by the side and the tip of the pile is given for pipe sections. In Figure 3, the tip and the side loads at failure are plotted against the pile diameters for the

Table 1
Summary of Arkansas River Lock and Dam No. 4 Pile Tests

Test No.	Type	Penetration ft	Hammer Type	Average Pile Failure Load, tons	
				Compression	Tension
1	12 in. pipe	53.1	140C	140	70
2	16 in. pipe	52.8	140C	195	91
2X	16 in. pipe	52.8	140C	210	-
3	20 in. pipe	53.0	140C	215	90
4	16 in. concrete	40.2	140C	170	71
5	16 in. concrete	51.0	140C	240	-
6	14 BP 73	40.0	80C	140	-
7	14 BP 73	52.1	80C	190	45
8	Timber	38.6	65C	80	25
9	14 BP 73	53.2	Bodine	210	-
10	16 in. pipe	53.1	Bodine	180	87
11	16 in concrete	38.8	Bodine	150	-

Table 2
Load Distribution in Pipe Piles

Test No.	Nominal Diameter in.	Penetration ft	Average Failure Load tons	Load Distribution			
				Tip Load		Skin Friction	
				Tons	Percent	Tons	Percent
1	12	53.1	140	34	24	106	76
2	16	52.8	195	58	30	137	70
2X	16	52.8	210	67	32	143	68
3	20	53.0	215	77	36	138	64
10	16	53.1	180	46	26	134	74

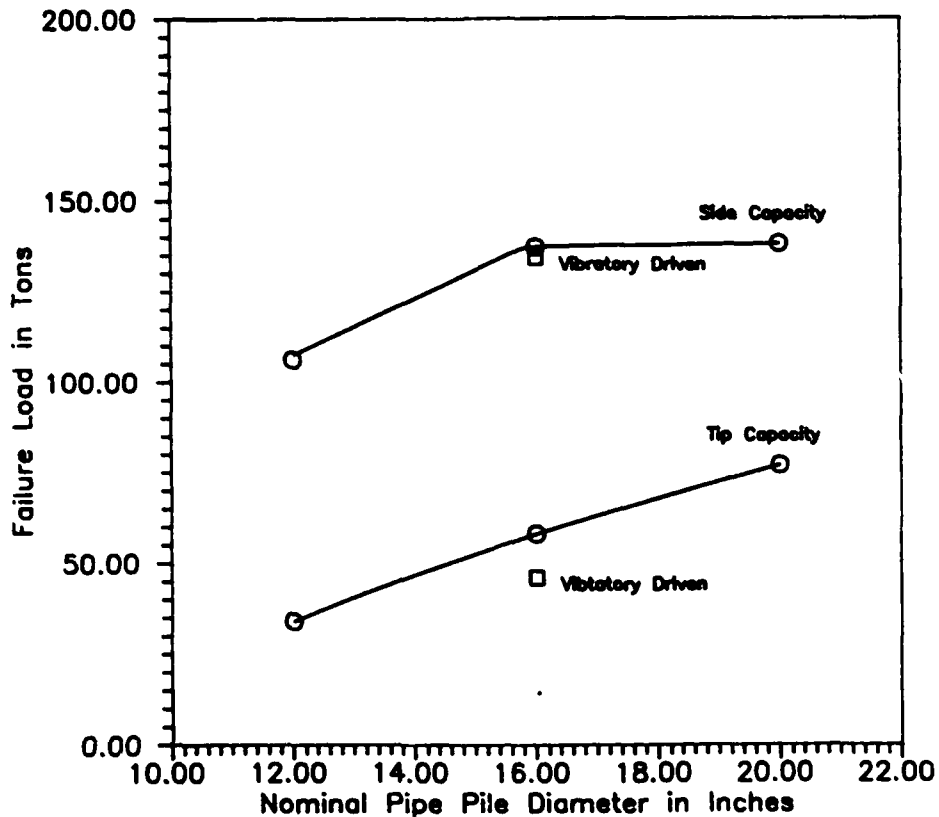

Figure 3. Failure load versus pipe pile diameter for Lock and Dam No. 4

various pipe piles tested. Test piles 2 and 10, being spaced just 8 ft apart, give a direct comparison between a pile installed by a Bodine sonic hammer (high frequency vibratory hammer) and similar pile driven with a Vulcan steam impact hammer. Comparing the load carried by the tip and side for test piles 2 and 10, 16-in. pipe piles, shows that the impact-driven pile has significantly more capacity, 58 tons, than the vibratory-driven pile, 46 tons, while the side capacities differed only by 3 tons.

27. Table 3 presents the distribution of the load being carried by the side and tip for the H-piles tested. Comparisons can be made between test piles 7 and 9. Test pile 9, which was driven with the Bodine sonic hammer, and had a capacity 30 tons greater than test pile 7 which was impact driven. Examination of the distribution of the load in the piles reveals that the vibratory-driven pile, test pile 9, had 14 tons less tip capacity than the impact-driven pile, test pile 7, but had substantially greater side-capacity by 34 tons.

Table 3
Load Distribution for H-Piles

Test No.	Penetration ft.	Average Failure Load tons	Load Distribution			
			Tip Load		Skin Friction	
			Tons	Percent	Tons	Percent
6	40.0	140	21	15	119	85
7	52.1	190	39	21	151	79
9	53.2	210	25	12	185	88

Arkansas River Lock and Dam No. 3

28. Exploration prior to the construction showed a stratigraphy of the site typical of Arkansas River alluvial soils and comparable to that found at Lock and Dam No. 4. However, during the initial pile driving and load testing, it became apparent that the soil characteristics at the site were not as anticipated. The initial compression and tension tests indicated that the design pile lengths would not carry the required loads with appropriate safety factors. Additional soil borings and field and laboratory tests were made. The results of these tests indicated that the removal of the overburden and/or scour during the cofferdam construction caused a stress relaxation within the soil mass resulting in a much looser foundation than initially determined. To determine the required pile lengths for the unexpected soil conditions and to investigate the acceptability of the contractor's proposal to drive the bearing piles with a Foster vibratory hammer, the US Army Engineer District, Little Rock, initiated a pile testing program (US Army Engineer District, Little Rock 1967). Appendix B includes compression and tension test results for six different piles.

Site description

29. Arkansas River Lock and Dam No. 3* is located at Arkansas River navigational mile 49.3, approximately 30 miles downstream from Pine Bluff, Arkansas (Figure 3). The geological conditions and stratigraphy are similar to those previously described for Lock and Dam No. 4.

30. The tests of interest were performed in the vicinity of the left

* US Army Engineer District, Little Rock. 1965. "Foundation Design for Lock and Dam No. 3, Arkansas River Navigation Project," unpublished.

riverbank. The top stratum varied from 0 to 30 ft in thickness and consisted of erratically stratified silt and lean clay. These surface soils are underlain by 90 to 130 ft of sand which is primarily gray and brown, clean, fine to medium sand with frequent lenses of clay, silt, and silty sand mixed with gravel lenses and occasional boulders. Below the sand deposit lies a Tertiary formation of stiff to hard, overly consolidated clay of low to high plasticity. The generalized soil profile shown in Figure 4 was derived for the test area. Prior to pile driving, the test site was excavated into the thick sand stratum. Approximately 40 to 50 ft of the surface stratum was removed.

Description of test-
ing program and results

31. Load tests were preformed to determine the axial capacity for different driving equipment, the lateral capacity of piles, load versus length curves for the site, and water table correction factors for the submerged condition. For each of the piles tested, a cluster of at least nine piles was driven with the center pile being the designated test pile. Tests were performed on piles in Monoliths L-7, L-14, R-8, R-9, R-19, SB-4, 10, 16, and 23 (Figure 5). The test program consisted of 15 compression, 7 tension, and 10 lateral load tests.

32. For this study, focusing on the comparison of capacities between vibratory-driven piles and impact-driven piles, only pile tests relevant to the objectives of this study are examined. The piles of interest were 14 BP 73, of lengths 45, 50, 55, 65, and 75 ft. Table 4 presents a summary of pile types, lengths, penetrations, hammer types, and failure loads for the piles that were examined for this study. The piles for tests 1, 3, 3A, 3B, and 9 were driven by a Foster 2-50, low-frequency, vibratory hammer and the piles for tests 2, 2A, 5, 6, and 7 were driven by a Vulcan 140C steam hammer.

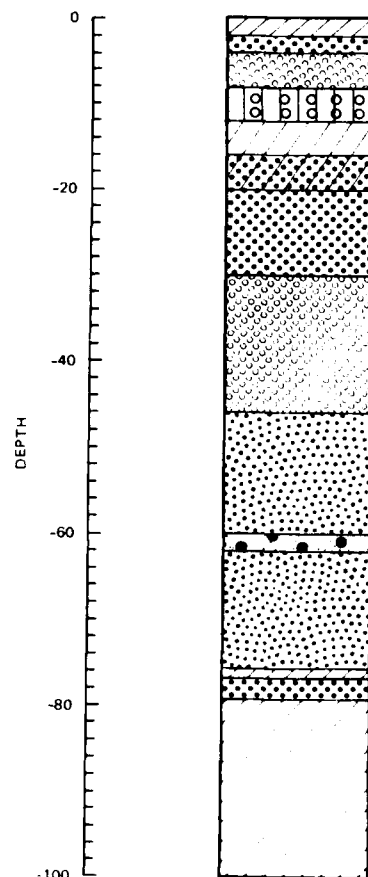
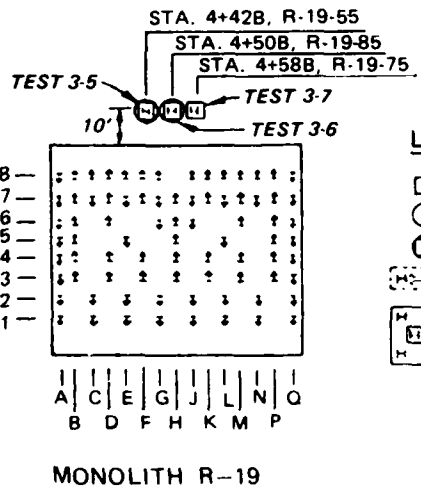
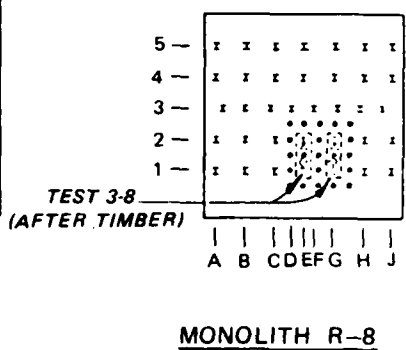
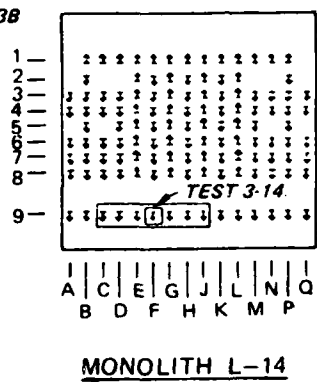
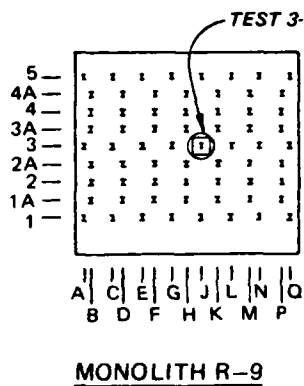
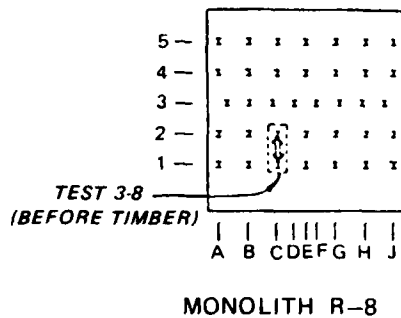
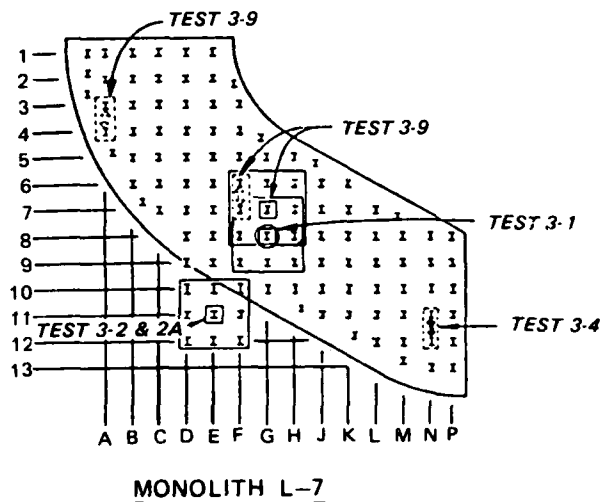

Figure 4. Generalized soil profile for Lock and Dam No. 3 pile test site



- LEGEND**
- COMPRESSION TEST
 - TENSION TEST
 - ◐ TENSION & COMPRESSION TEST
 - ▨ LATERAL TEST
 - ⊞ PILE CLUSTER (TEST PILE)
 - ▬ TIMBER PILE

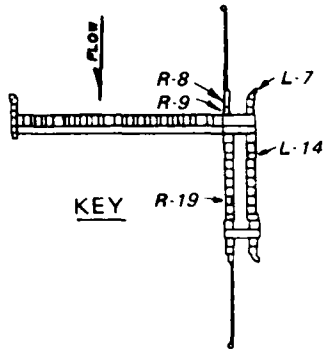
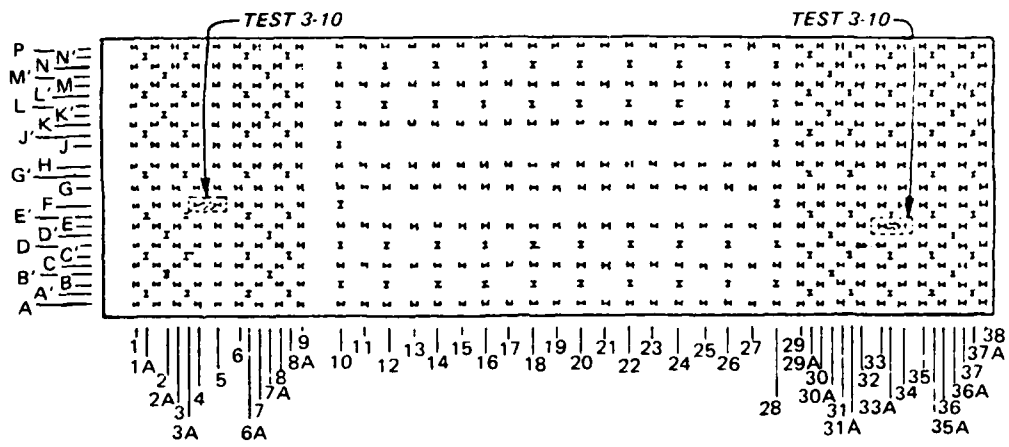
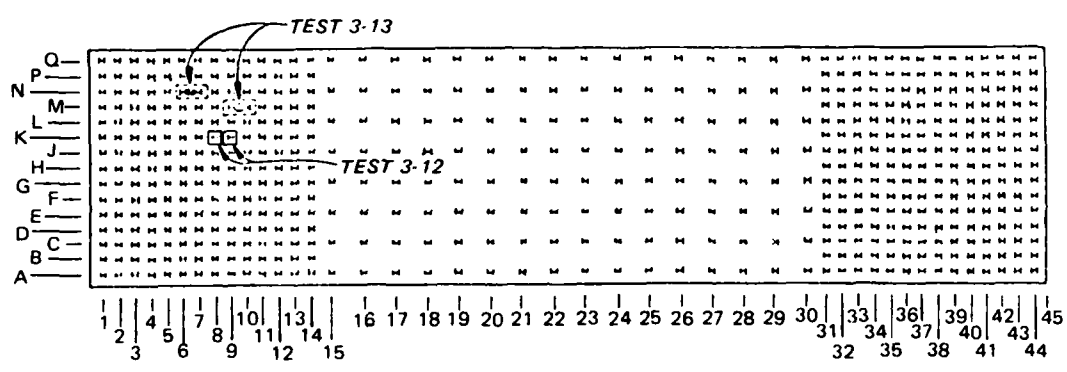

Figure 5. Location of pile tests (Continued)



MONOLITH 10



MONOLITH 23

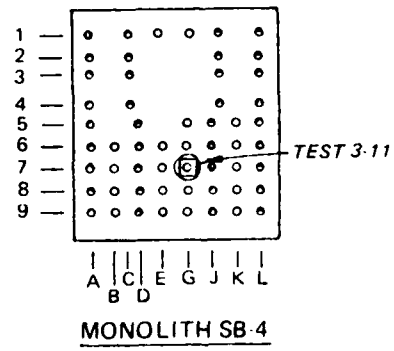

MONOLITH SB-4

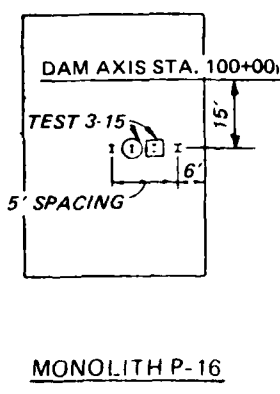

MONOLITH P-16

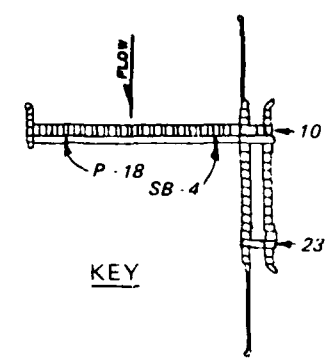

LEGEND

- COMPRESSION TEST
- TENSION TEST
- ⊙ TENSION & COMPRESSION TEST
- ⊞ LATERAL TEST

Figure 5. (Cont'd)

Table 4
Summary of Arkansas River Lock and Dam No. 3
H-Pile Tests

Test No.	Hammer*	Penetration ft	Failure Loads			
			Compression, tons		Tension, tons	
			As Tested	Adjusted**	As Tested	Adjusted**
1	FR 2-50	42.3	85	71	25	22
2	VC 140C	42.8	134	104	34	27
2A	VC 140C	61.8	185	145	-	-
3	FR 2-50	46.7	105	80	-	-
3A	FR 2-50	46.7	120	92	31	23
3B	FR 2-50	61.8	145	117	-	-
5	VC 140C	52.8	150	128	39	32
6	VC 140C	63.0	175	155	51	44
7	VC 140C	73.0	215	190	-	-
9	FR 2-50	42.9	127	88	-	-

* FR2-50 = Foster vibratory hammer; VC 140C = Vulcan steam hammer.

** Adjusted for water level.

33. During the driving of the piles for these tests, the sand surrounding the piles loosened and voids, 5 to 10 ft deep, formed between the flanges near the surface. Attempts were made to fill the voids and to compact the sand surrounding the piles. For pile test 3A and 3B, a concrete vibrator was used to place and increase the density of the sand in the flanges around the top of the pile. For test 2A, the voids in the flanges were filled with sand and water without compaction. For test 9, the voids were filled with sand and water and the area surrounding the pile was compacted by vibroflotation.

34. The main objectives of this portion of the testing program were to obtain data for determining the pile lengths needed for this lock and dam and to make a direct comparison between piles driven with a vibratory and an impact hammer. Figure 6 shows the failure loads versus depth of penetration for the compression tests. This figure shows that the impact-driven piles have a substantially higher capacity than the vibratory-driven piles by an average of 32 tons. Figure 7 presents the tension failure loads versus the depth of penetration. This figure reveals that the impact-driven piles have only a slightly greater capacity, 5 tons, than the vibratory-driven piles.

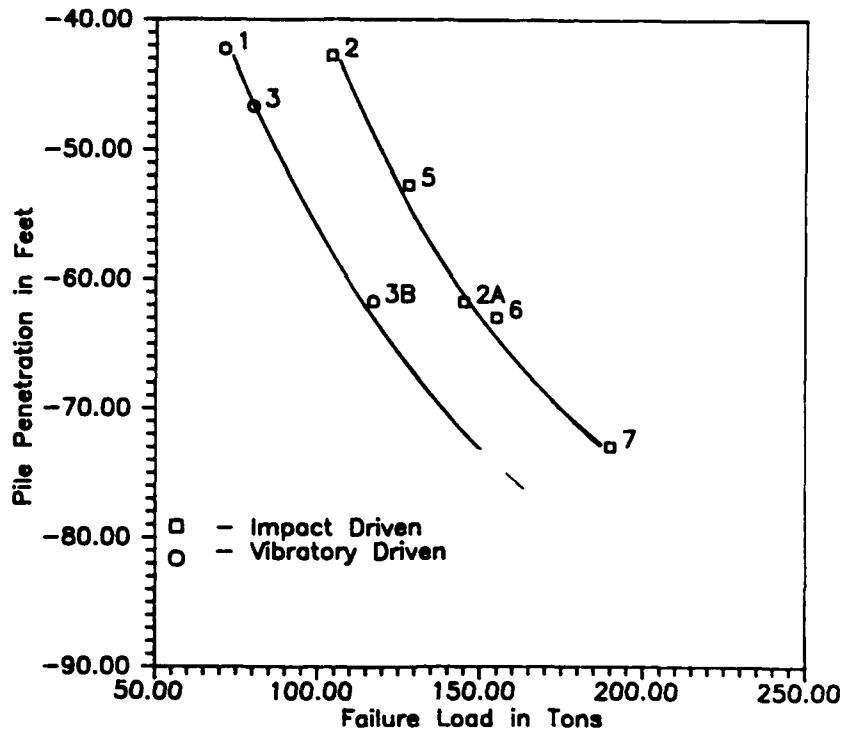

Figure 6. Failure load versus depth for compression tests for Lock and Dam No. 3

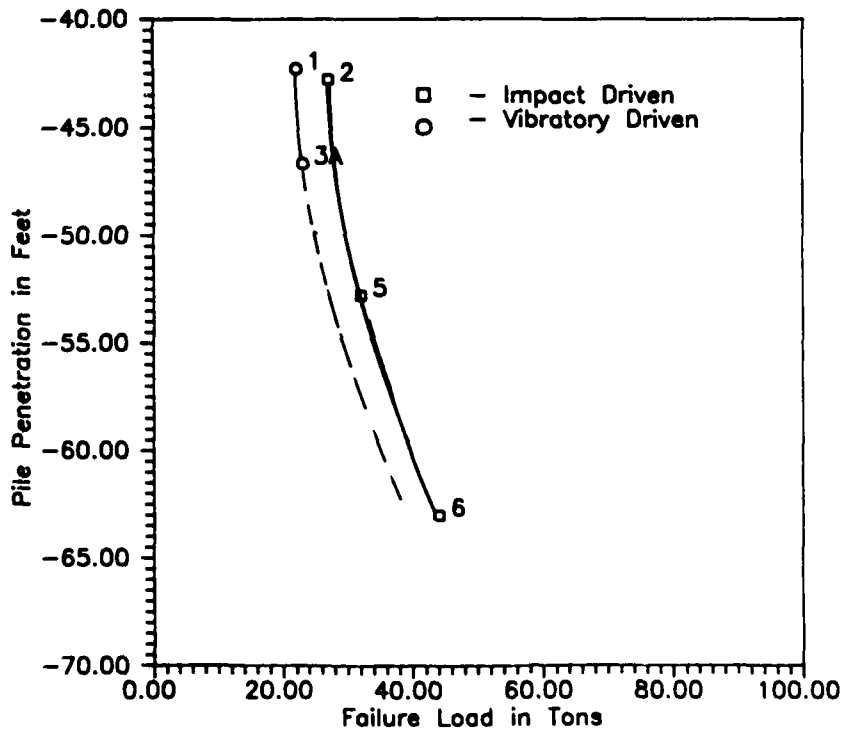

Figure 7. Failure load versus depth for tension tests for Lock and Dam No. 3

Crane Rail Tracks (Mazurkiewicz 1975)

35. During the construction of pile foundations for crane rail tracks for jib and gantry cranes it was decided to investigate the use of a vibratory hammer for the pile driving instead of a drop hammer. It was believed for the subsoil conditions at the sites that the vibratory-driven piles should give the same bearing capacities as the impact-driven piles and would shorten the construction time. To substantiate this assumption, a series of pile load tests were conducted to make direct comparisons between piles driven with a vibratory hammer and an impact hammer. Mazurkiewicz (1975) reported the results and his conclusions from the pile testing program. Site and pile descriptions and test results have been summarized in this section.

36. In the vicinity of the construction sites and pile tests, the subsurface profile consisted of a 3- to 5-ft layer of fill over a 3- to 6-ft layer of peat. The peat is underlain by layers of fine to medium sand and sandy gravels which overlie a stratum of silty clay. Penetration tests show a linear increase with depth through the sand and no trend in the clay. The stratification and representative penetration records are shown in Figure 8.

37. The load tests were performed on prestressed concrete piles with a diameter of 13.4 in. (34 mm) and lengths from 42.7 ft (13 m) to 88.6 ft (27 m). The comparison tests were made for 11 piles driven by a drop hammer and 11 by a vibratory pile driver. The distance between the two piles used for comparison, one impact driven and one vibratory driven, was 10 to 25 ft. The impact driving was performed with a drop hammer with a weight of 5 tons and a free-fall distance of 15.8 in. (40 cm). The vibratory hammer had a frequency of 18.3 Hz, an amplitude of 0.39 in. (9.8 mm), and a vibratory weight of 5.6 tons.

38. Table 5 shows the failure loads obtained from the 11 sets of load tests. Also, the ratios between the failure loads of the vibratory-driven and impact-driven piles are given. The load settlement curves for three typical test sets are presented in Figures 9, 10, and 11. Figure 12 is a plot of failure loads versus depth of penetrations for the 11 test sets. For each test set of piles, the impact-driven piles showed substantially higher failure load than the vibratory-driven piles.

39. The influence of time on the ratio of axial capacity of the vibratory- and impact-driven piles was also studied. It was found, if the

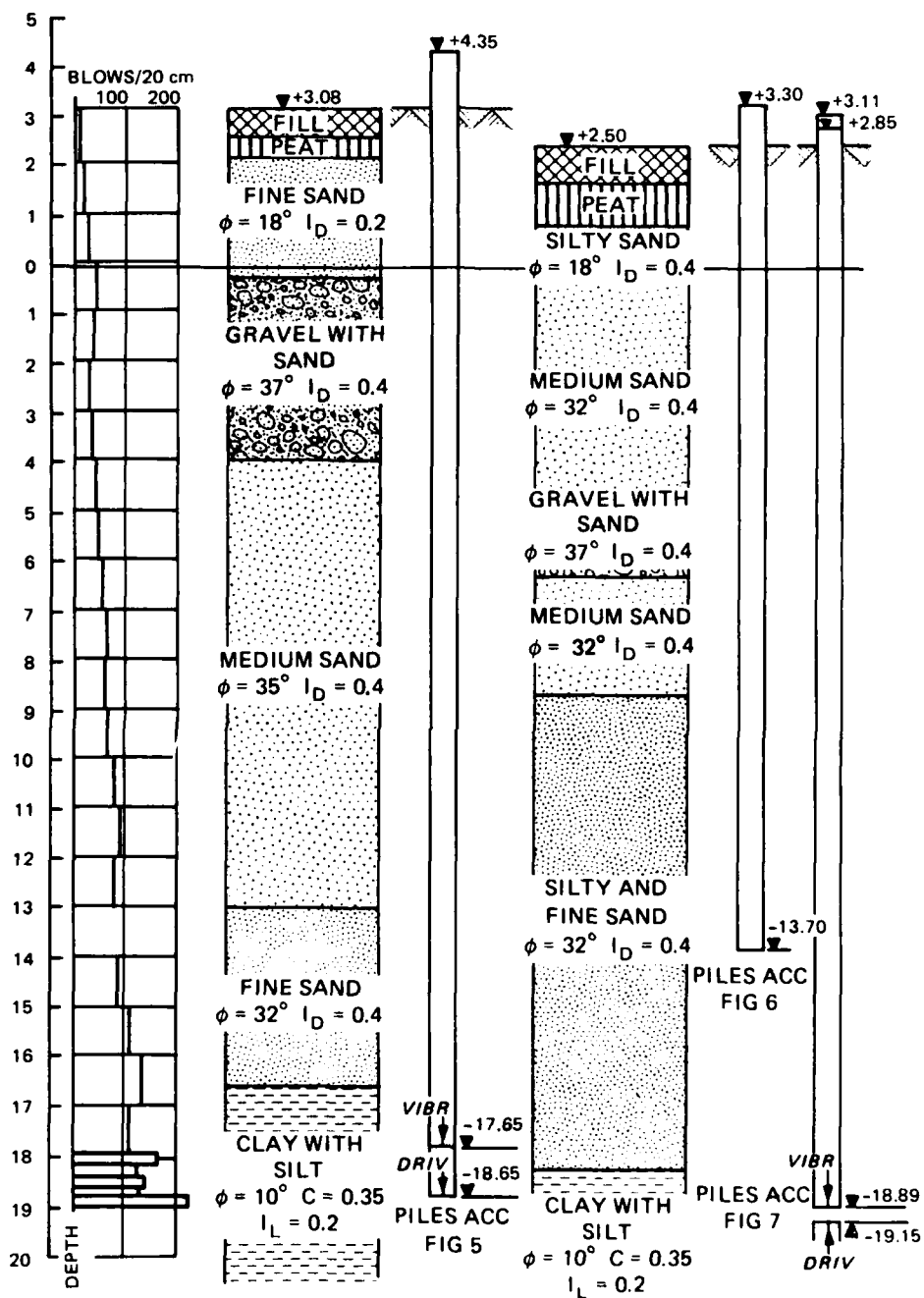

Figure 8. Stratification for the crane rail track test sites

Table 5
Summary of Crane Rail Tracks Pile Testing Program

<u>Pile Test Set</u>	<u>Length ft (m)</u>	<u>Failure Load in Compression</u>		<u>Ratio</u>
		<u>Vibratory Driven tons (mtons)</u>	<u>Impact Driven tons (mtons)</u>	
1	42.7 (13)	38.5 (35)	92.4 (84)	0.42
2	42.7 (13)	46.2 (42)	52.8 (48)	0.88
3	42.7 (13)	71.5 (65)	93.5 (85)	0.76
4	57.8 (17)	44.0 (40)	69.3 (63)	0.63
5	57.8 (17)	50.6 (46)	124.3 (113)	0.41
6	59.1 (18)	28.6 (26)	115.5 (105)	0.25
7	72.2 (22)	103.4 (94)	159.5 (145)	0.65
8	75.5 (23)	55.0 (55)	82.5 (75)	0.67
9	75.5 (23)	77.0 (70)	148.5 (135)	0.52
10	75.5 (23)	38.5 (35)	66.0 (60)	0.54
11	88.6 (27)	93.5 (85)	115.5 (105)	0.81

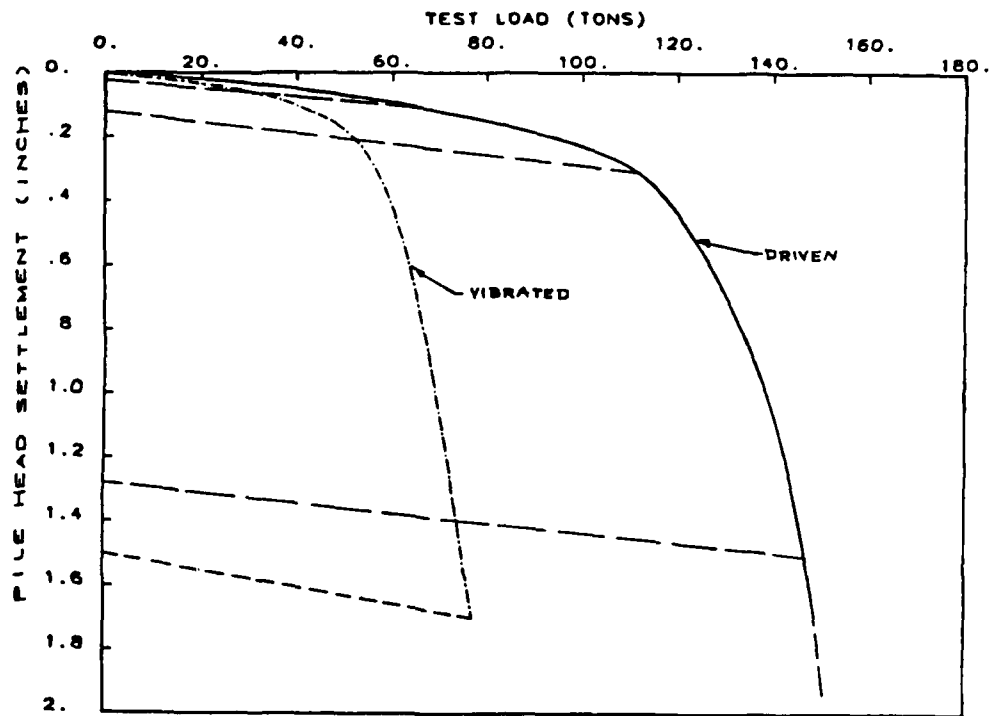

Figure 9. Crane rail tracks load tests for 17-m pile

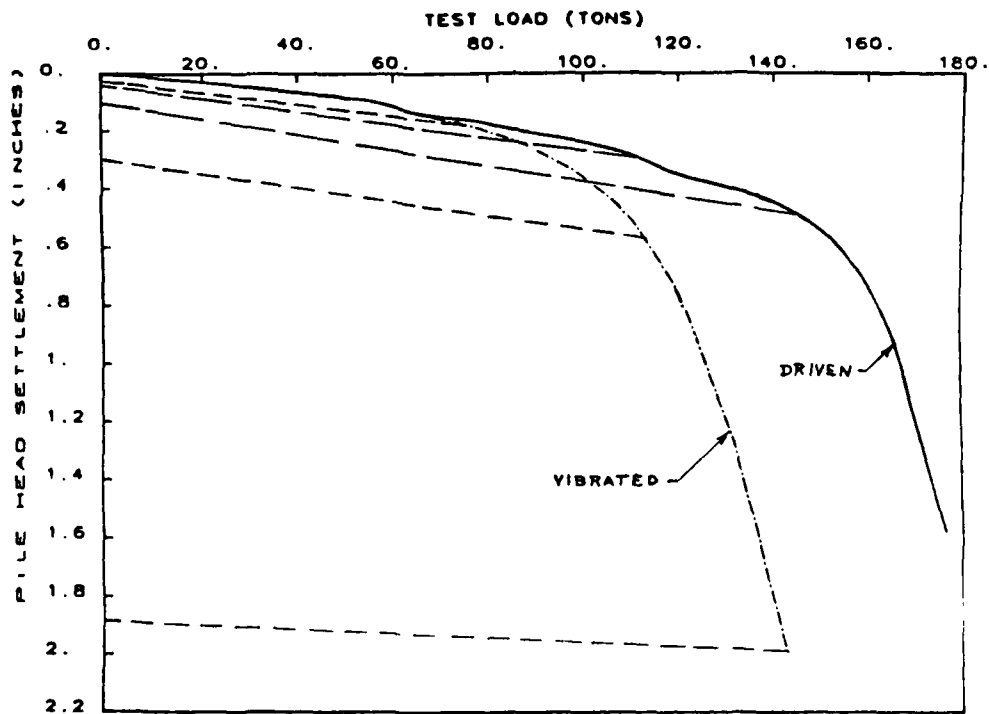

Figure 10. Crane rail tracks load tests for 22-m pile

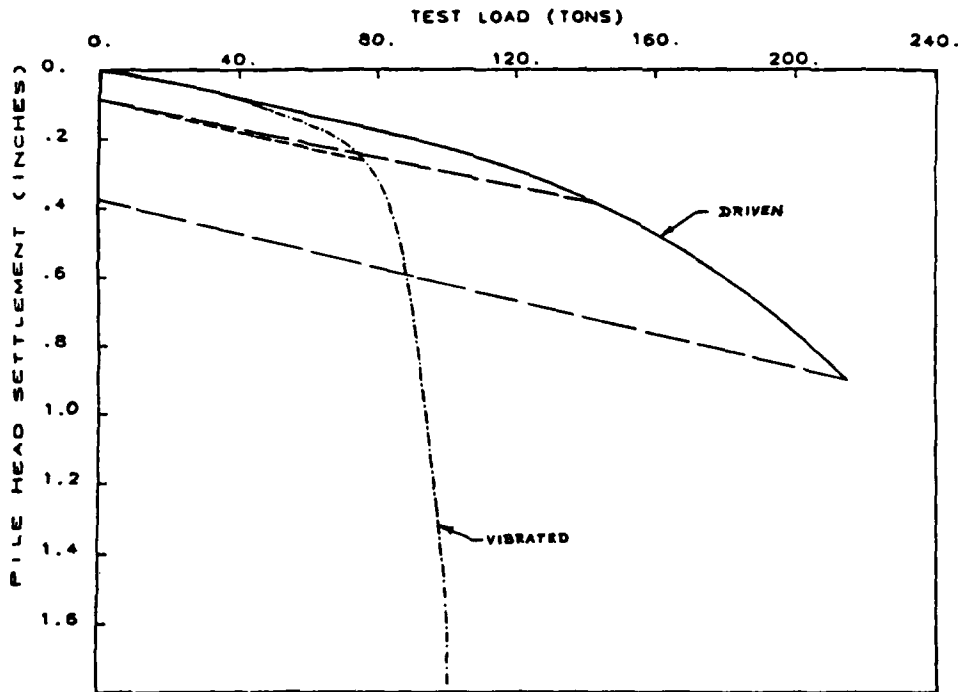

Figure 11. Crane rail tracks load tests for 23-m pile

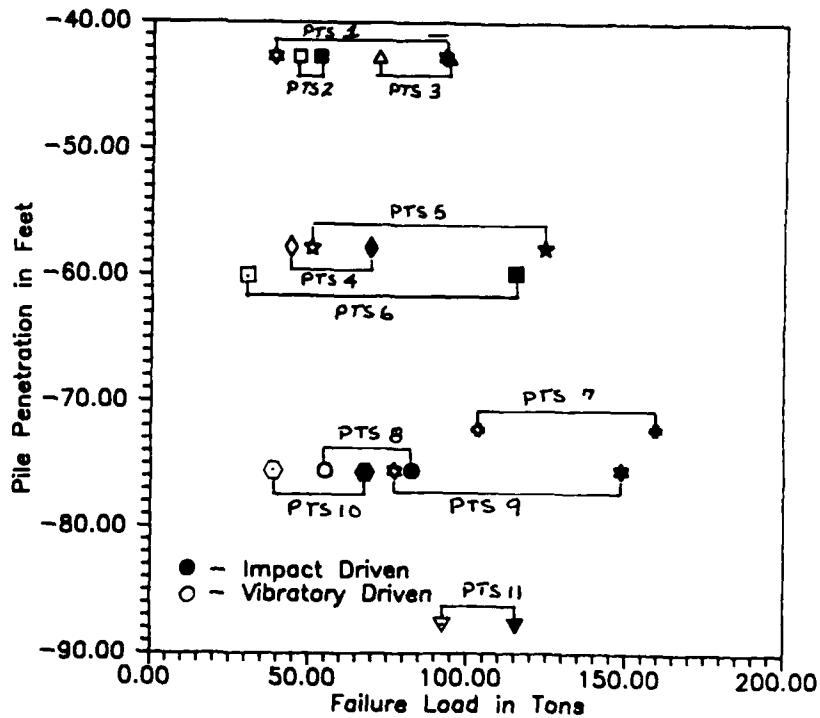

Figure 12. Failure load versus depth of penetration for the crane rail tracks pile testing program

piles were tested after 4, 12, 30, or more days, the difference in capacity remained unchanged. However, it could be stated that with time some increase in capacity did occur for both methods of installation.

Geochemical Building, Harvard University and Wall
No. 7, I-95, Providence, Rhode Island

40. These are two sets of tests reported by Jeyapalan (1983)*. These tests were conducted to compare the performance of impact-driven piles with piles driven with a Bodine sonic hammer. The tests at Harvard University were conducted in preparation of the foundation for a new Geochemical Building and the tests at the Wall No. 7, I-95, site were carried out as part of the general testing program for the wall. The piles were cast-in-place concrete piles formed by driving corrugated steel shells with an internal mandrel. After driving, the mandrel is collapsed and withdrawn and the shell is filled with concrete. The soil profiles and the pile descriptions are presented in Figures 13 and 14. The test results are presented in Figures 15 and 16. The results from these tests indicate that the sonically driven piles performed superiorly to the impact-driven piles.

* J. K. Jeyapalan. 1983. "Axial Capacity of Vibro-Driven Piles," Draft report submitted to the US Army Engineer Waterways Experiment Station, Vicksburg, Miss.

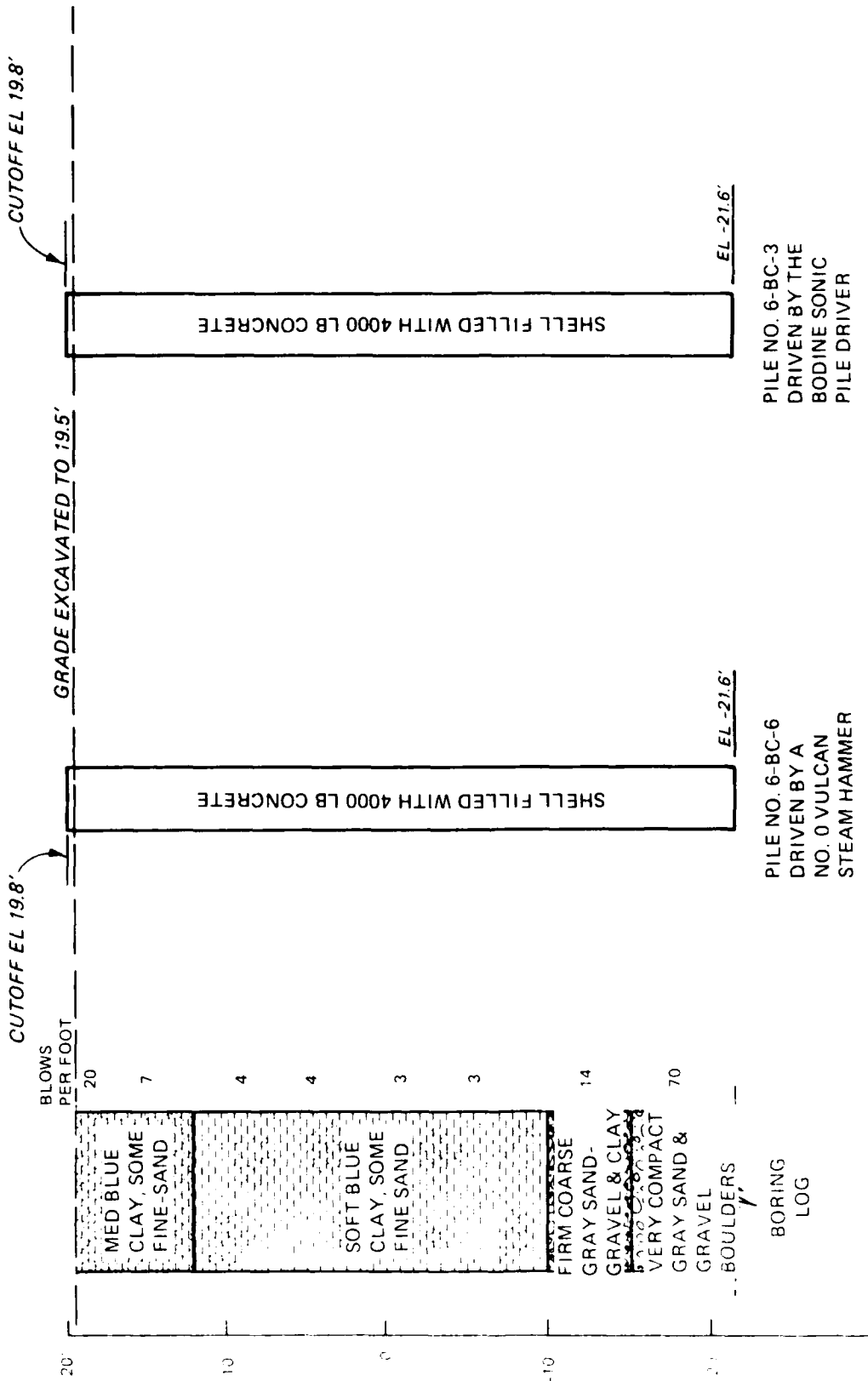

Figure 13. Soil profile for the Geochemical Building site

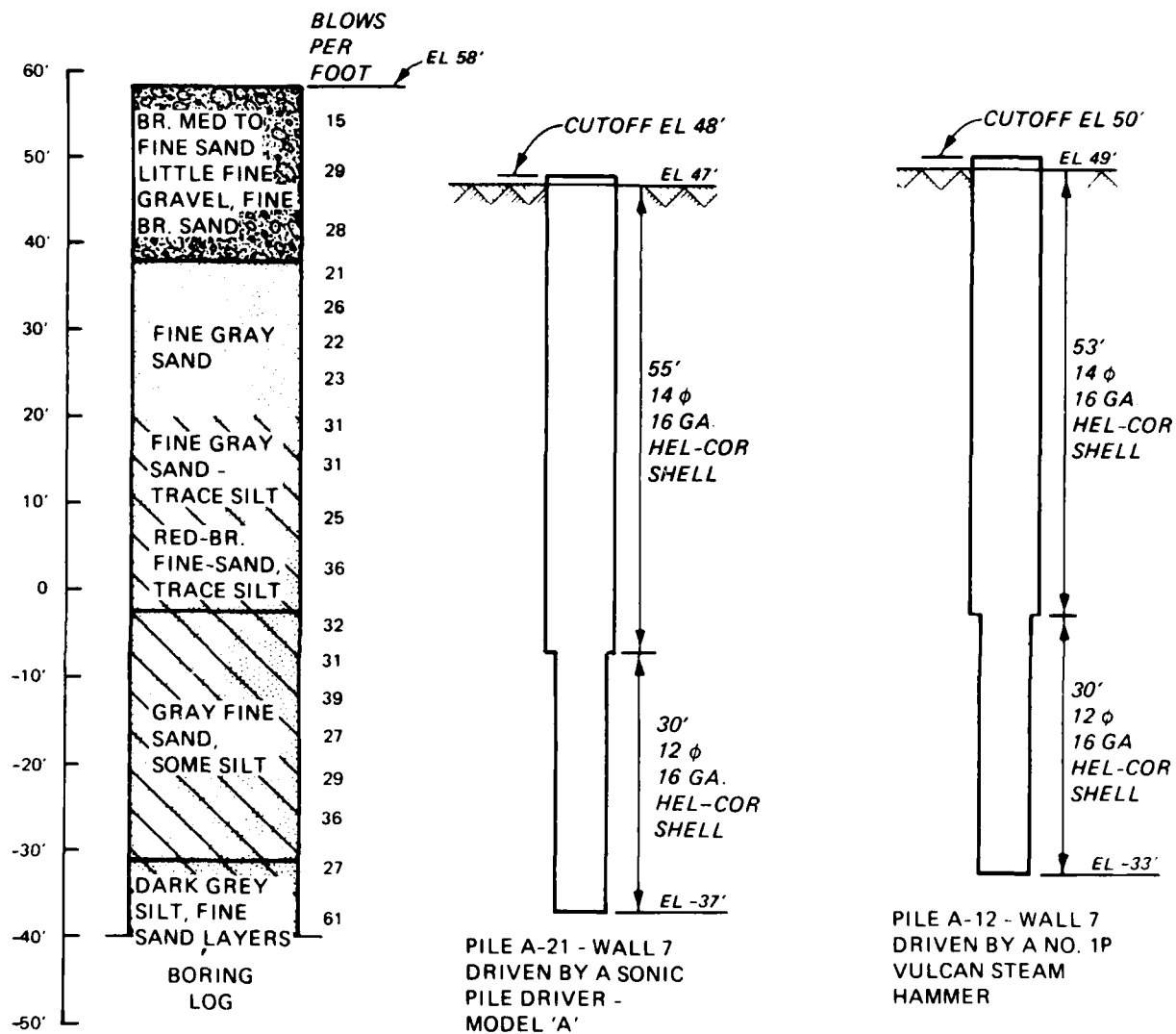

Figure 14. Soil profile for Wall No. 7, I-95

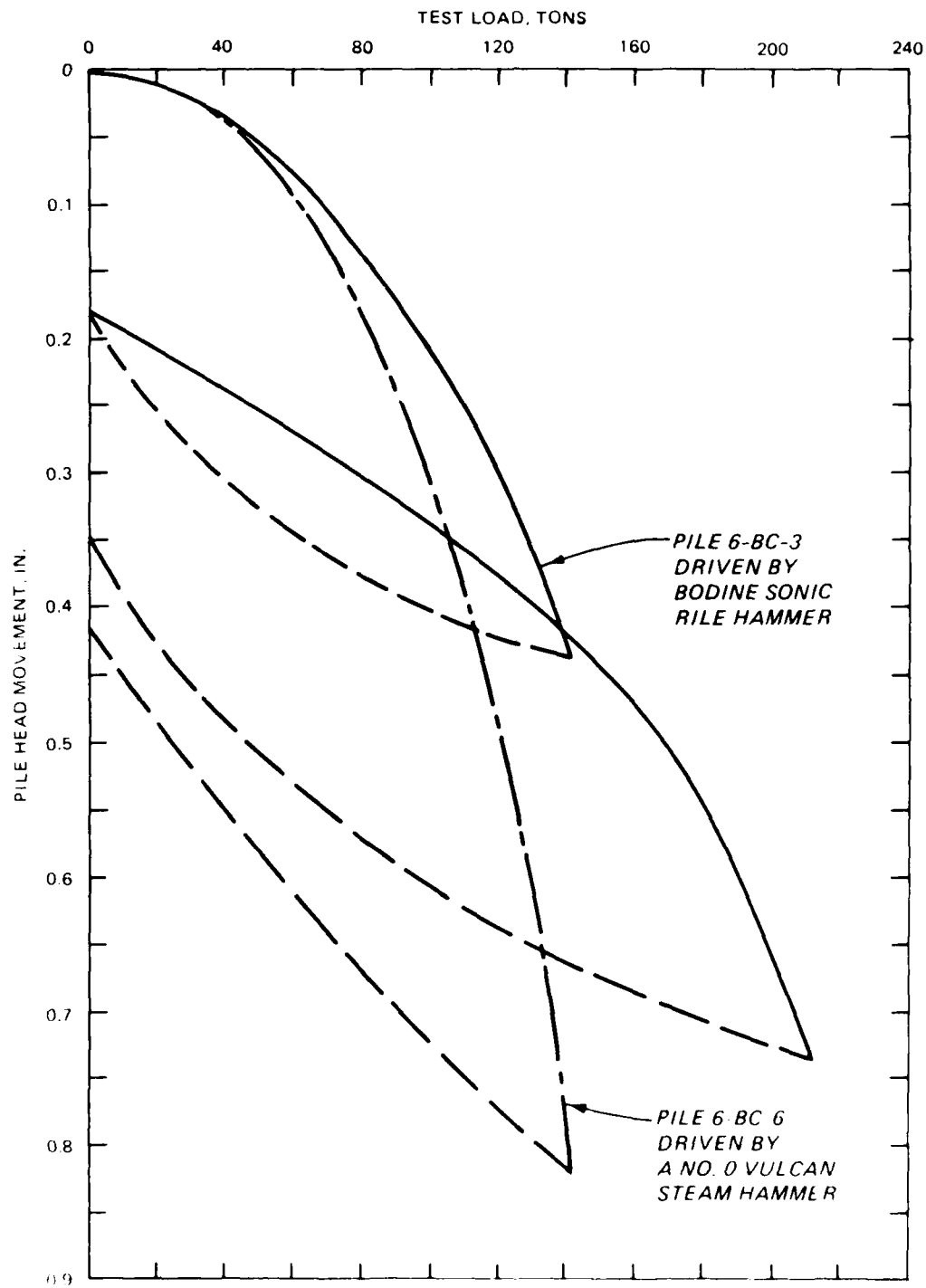

Figure 15. Pile load tests for Geophysical Building

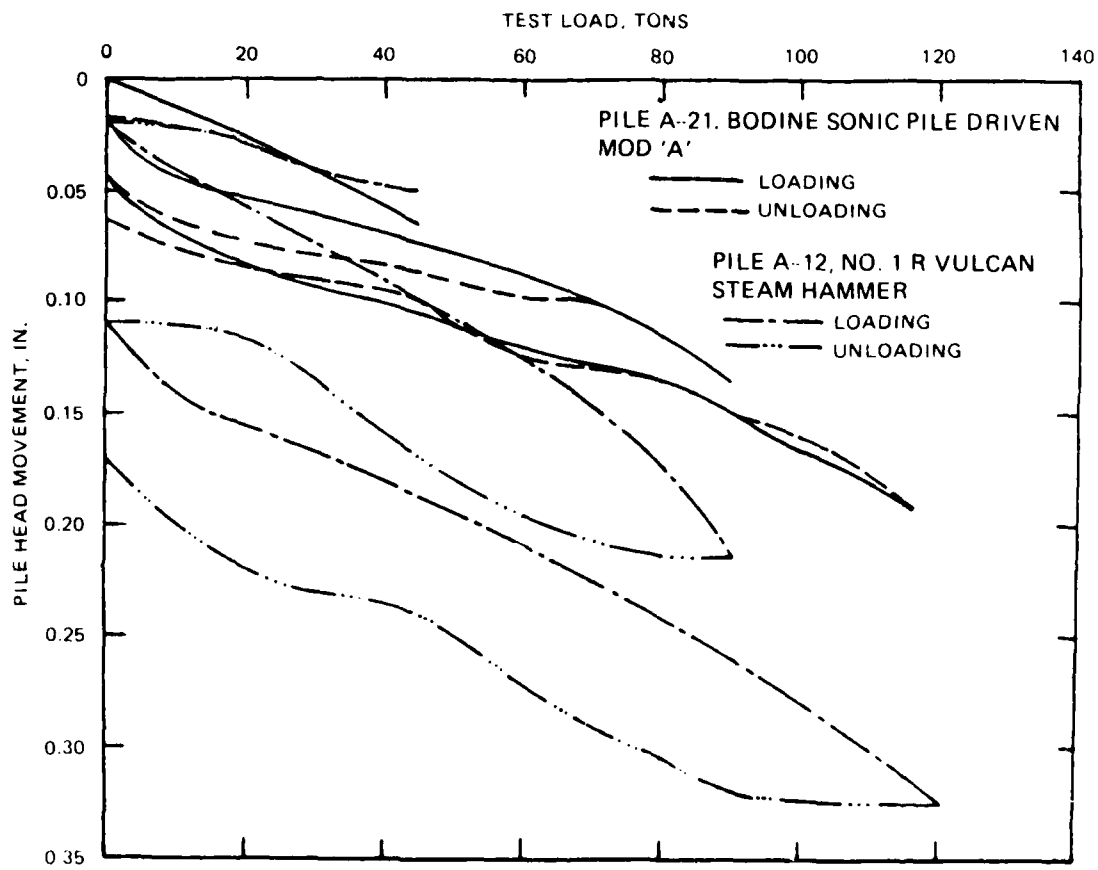

Figure 16. Pile load tests for Wall No. 7, I-95

PART IV: SUMMARY AND CONCLUSIONS

Summary of Field Tests

41. With the exceptions of the Harvard University, I-95, and Arkansas River Lock and Dam No. 4 H-pile tests, the piles driven by the impact hammers had a significantly greater axial capacity than those driven with vibratory hammers. In Figure 17, the failure load for the impact-driven piles is plotted versus the failure load of the vibratory-driven piles. The diagonal line in the plot represents a one-to-one correspondence between the impact and vibratory capacity. Points below this line show a greater capacity for impact-driven piles and points above this line show a greater capacity for vibratory-driven piles. This plot shows that for the majority of the pile tests examined in this study the vibratory-driven piles have less axial capacity than impact-driven piles.

Reduced capacity for vibratory-driven piles

42. A possible explanation for the reduced capacity for vibratory-driven piles is that the vibratory-driven process results in less compaction at the pile tip, thus lowering the tip capacity. Hunter and Davisson (1969), in their investigation of the Arkansas River Lock and Dam No. 4 pile tests, explained the difference in capacities by examining the driving process. They state that a vibratory hammer is very effective in overcoming the side resistance or skin friction along a pile in sand, but the very nature of the longitudinal pile vibration requires a small tip force. Therefore, the soil beneath the tip of a vibratory-driven pile remains relatively undisturbed as compared to its state before driving. In comparison, Meyerhof (1959) showed that impact driving in sand results in substantial compaction beneath the tip which prestresses the surrounding soil mass.

43. Evidence of this can be found in the Arkansas River Lock and Dam No. 4 pile testing program. Figure 18 presents a plot of the tip load, skin friction, and total pile load at failure for impact-driven piles versus the vibratory-driven piles for Lock and Dam No. 4. The plot reveals that for each comparable set of piles the tip load at failure for the vibratory-driven piles is lower than that for the impact-driven piles. Even for the set of H-piles, for which the vibratory-driven pile had a greater total load at failure, the

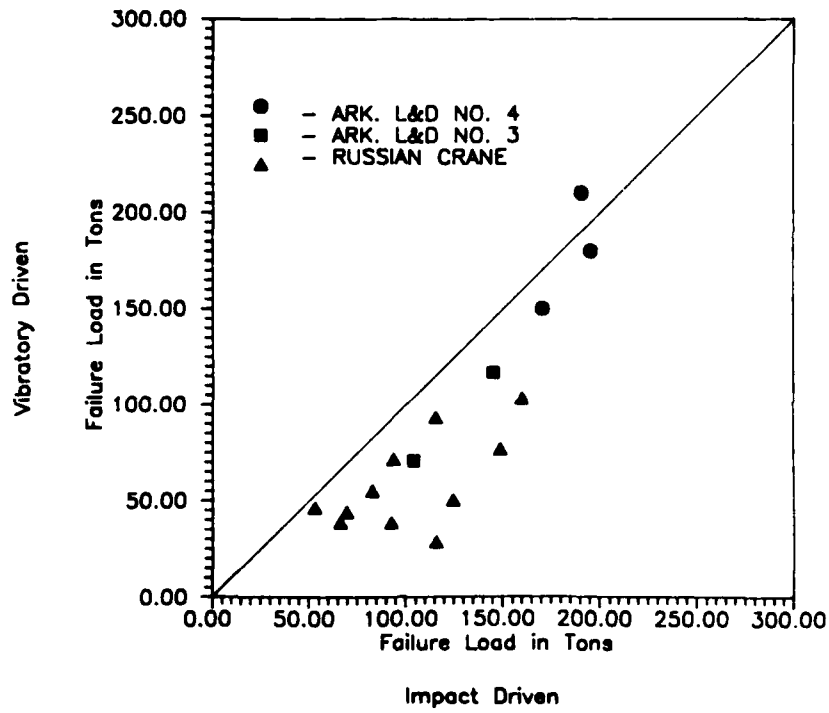

Figure 17. Comparison of impact- and vibratory-driven piles

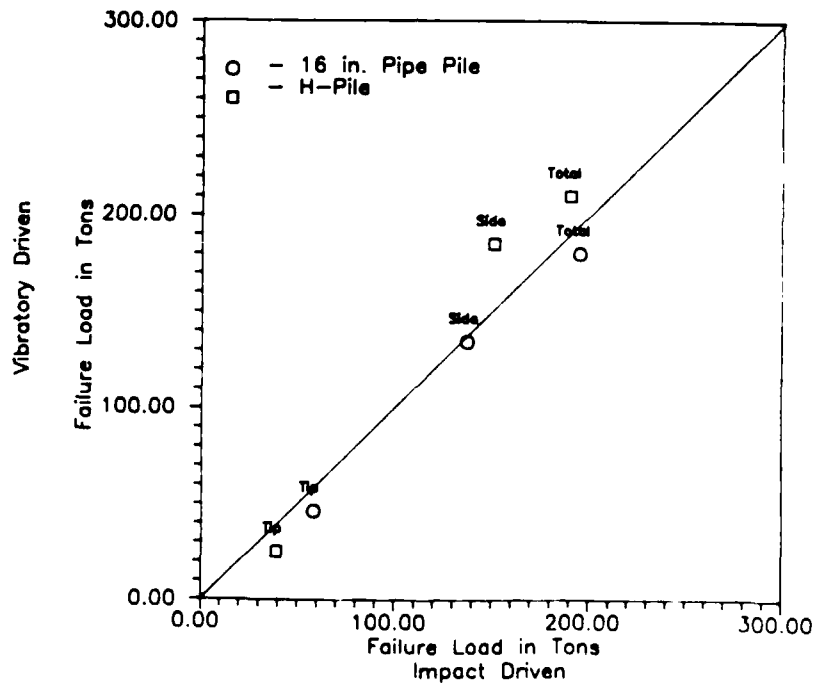

Figure 18. Comparison of load distribution of impact- and vibratory-driven piles for Look and Lam No. 4

load carried by the tip of the vibratory-driven pile was 14 tons less than the impact-driven pile.

44. Further supporting evidence of this can be found in the crane rail testing program. To investigate whether a pile previously vibrated into place, and then driven a short distance by drop hammer would achieve the same ultimate capacity as a pile completely driven with a drop hammer, some additional tests were performed in the crane rail testing program. From these tests it was discovered that vibratory-driven piles which had the last 9 ft of penetration driven by a drop hammer would reach the same failure load as purely impact-driven piles with the same penetration.

Piles retested

45. As mentioned in the introduction of this report, the axial capacity of the piles at Red River Lock and Dam No. 1 were significantly less than anticipated. In an attempt to investigate possible reasons for the reduced capacity, several of the piles were retested. Figures 19, 20, and 21 show plots of the tip load versus displacement for three of the load tests and their retest at Red River Lock and Dam No. 1. In these plots, the retests have significantly greater load carrying capacity than when previously tested.

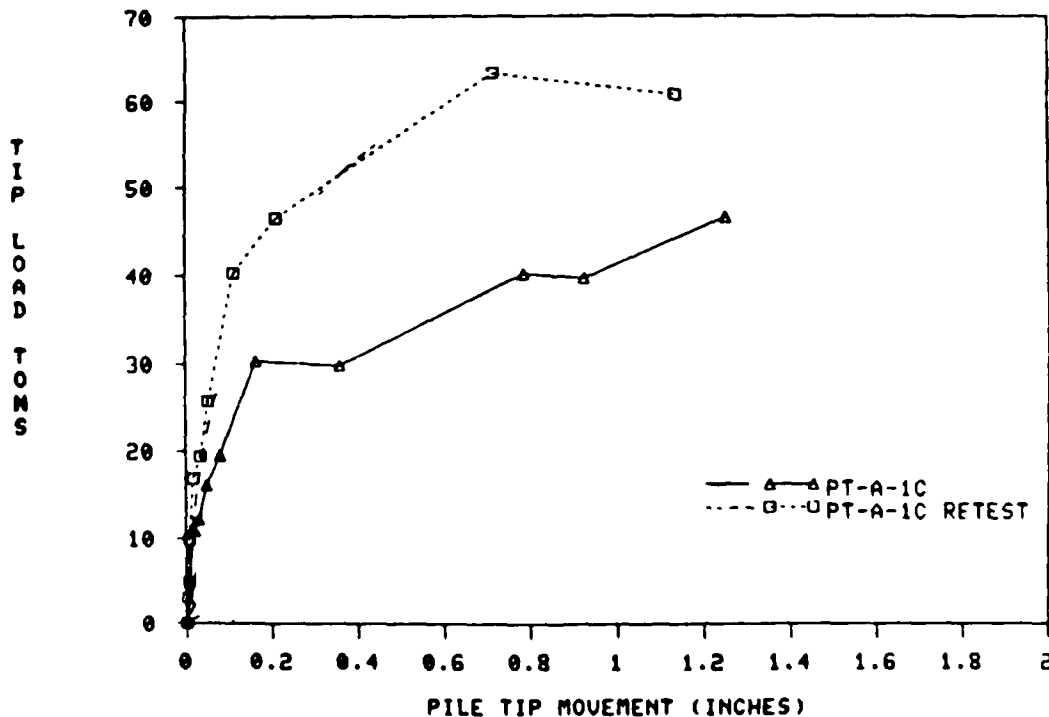

Figure 19. Tip load versus pile tip movement for Pile A-1C, Red River Lock and Dam No. 1 (Mosher 1984)

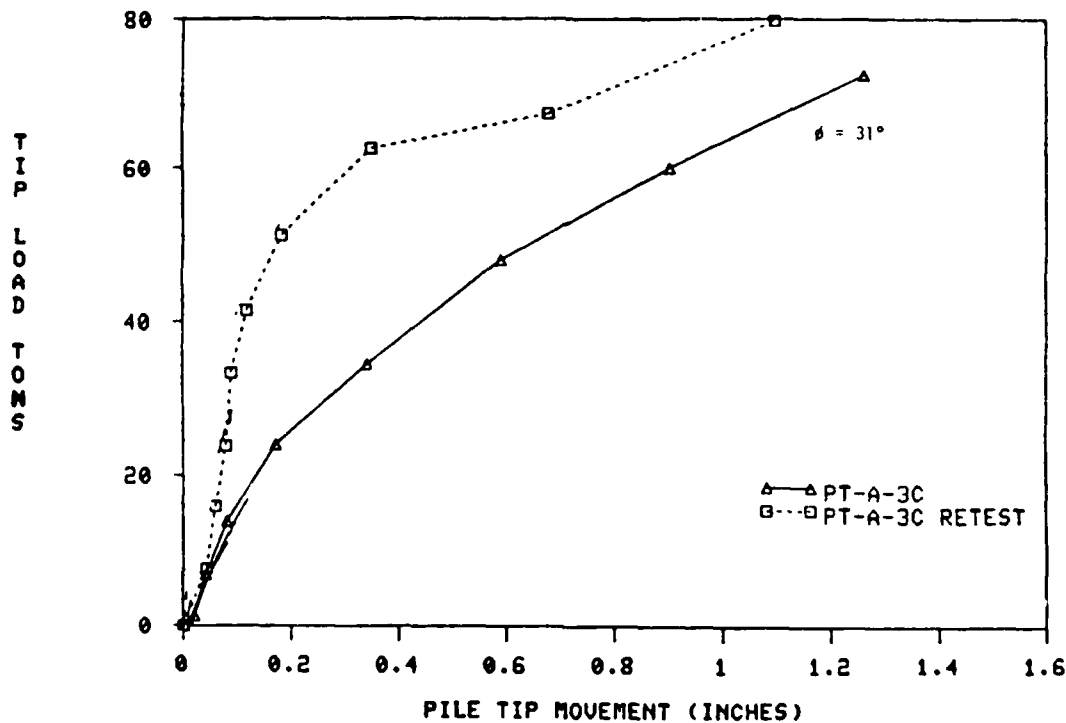

Figure 20. Tip load versus pile tip movement for Pile A-3C, Red River Lock and Dam No. 1 (Mosher 1984)

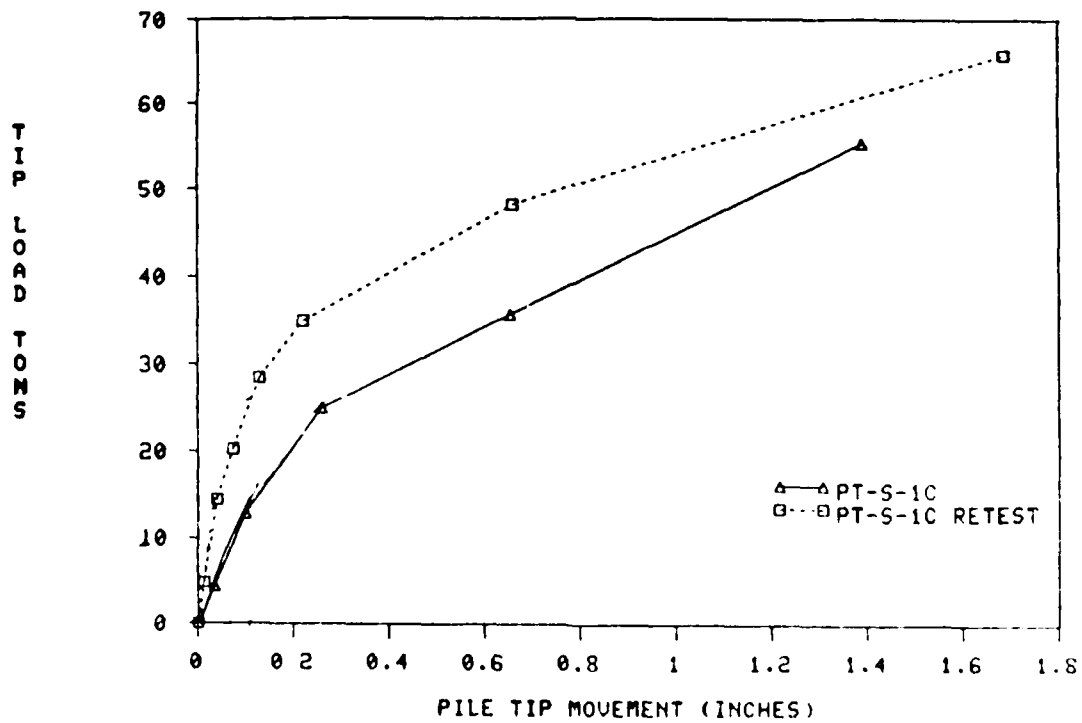

Figure 21. Tip load versus pile tip movement for Pile S-1C, Red River Lock and Dam No. 1 (Mosher 1984)

A large portion of the additional capacity exhibited by the retested piles resulted from the compaction of the soil surrounding the tip during the first load tests. The influence of time may also have had a small effect on the increased capacities.

Conclusions

46. The results of the field tests presented in this report show that for a significant majority of cases, the installation of piles in sand with a vibratory hammer of any type (high or low frequency) resulted in less axial capacity than impact-driven piles at the same site. Additional information was found showing that the influence of time affects piles driven by both methods equally and that additional driving by an impact hammer of vibratory-placed pile causes an increased in its axial capacity to that of a pile driven totally by an impact hammer.

REFERENCES

- Barkan, D. D. (1957). "Foundation Engineering and Drilling by the Vibratory Method," Proceedings of the 4th International Conference on Soil Mechanics and Foundation Engineering, London, pp 3-7.
- Ellison, R. D. (1969). "An Analytical Study of the Mechanics of Single Pile Foundations," Ph.D. dissertation, Carnegie-Mellon University, Pittsburg, Pa.
- Engineering News Record. 1961 (Nov). "Sonics Drive a Pile 71 Feet While Steam Drives Another 3 Inches," Vol 167, No. 19.
- Fruco and Associates. (1964). "Pile Driving and Loading Tests," US Army Engineer District, Little Rock, Ark.
- Hunter, A. A., and Davisson, M. T. (1969). "Measurement of Pile Load Transfer," Performance of Deep Foundations, American Society for Testing Materials, STP 444, pp 106-117.
- Mazurkiewicz, B. K. (1975). "Influence of Vibration of Piles on their Bearing Capacity," Proceedings First Baltic Conference, Soil Mechanics and Foundation Engineering, Gdansk, Poland, Vol 3, Sec III, pp 143-153.
- Meyerhof, G. G. (1959). "Compaction of Sands and Bearing of Piles," Journal, Soil Mechanics and Foundations Division, American Society of Civil Engineers, Vol 85, No. SM6, Proceedings Paper 2292, pp 1-29.
- Mosher, R. L. (1984). "Load-Transfer Criteria for Numerical Analysis of Axially Loaded Piles in Sand," Technical Report K-84-1, US Army Engineer Waterways Experiment Station, Vicksburg, Miss.
- Robinsky, E. I., and Morrison, C. F. (1964). "Sand Displacement and Compaction Around Model Friction Piles," Canadian Geotechnical Journal, Vol 1, No. 4, pp 189-204.
- US Army Engineer District, Little Rock. (1967). "Data and Recommendation for Steel Bearing Pile Foundation in Sand Based on Experience at Lock and Dam No. 3 and David D. Terry Lock and Dam (No. 6), Arkansas River Navigation Project," Little Rock, Ark.

APPENDIX A: PILE TESTS,
ARKANSAS RIVER LOCK AND DAM NO. 4

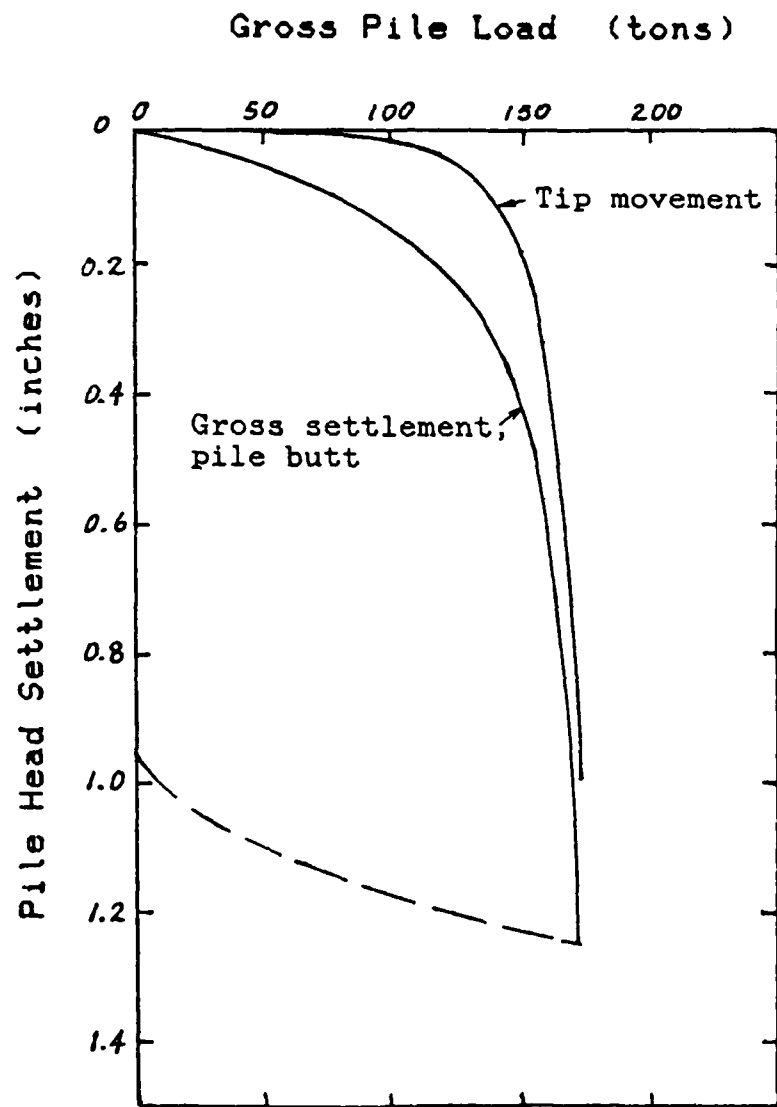

Figure A1. Compression test results - Test Pile 1 (12.75-in. pipe pile)

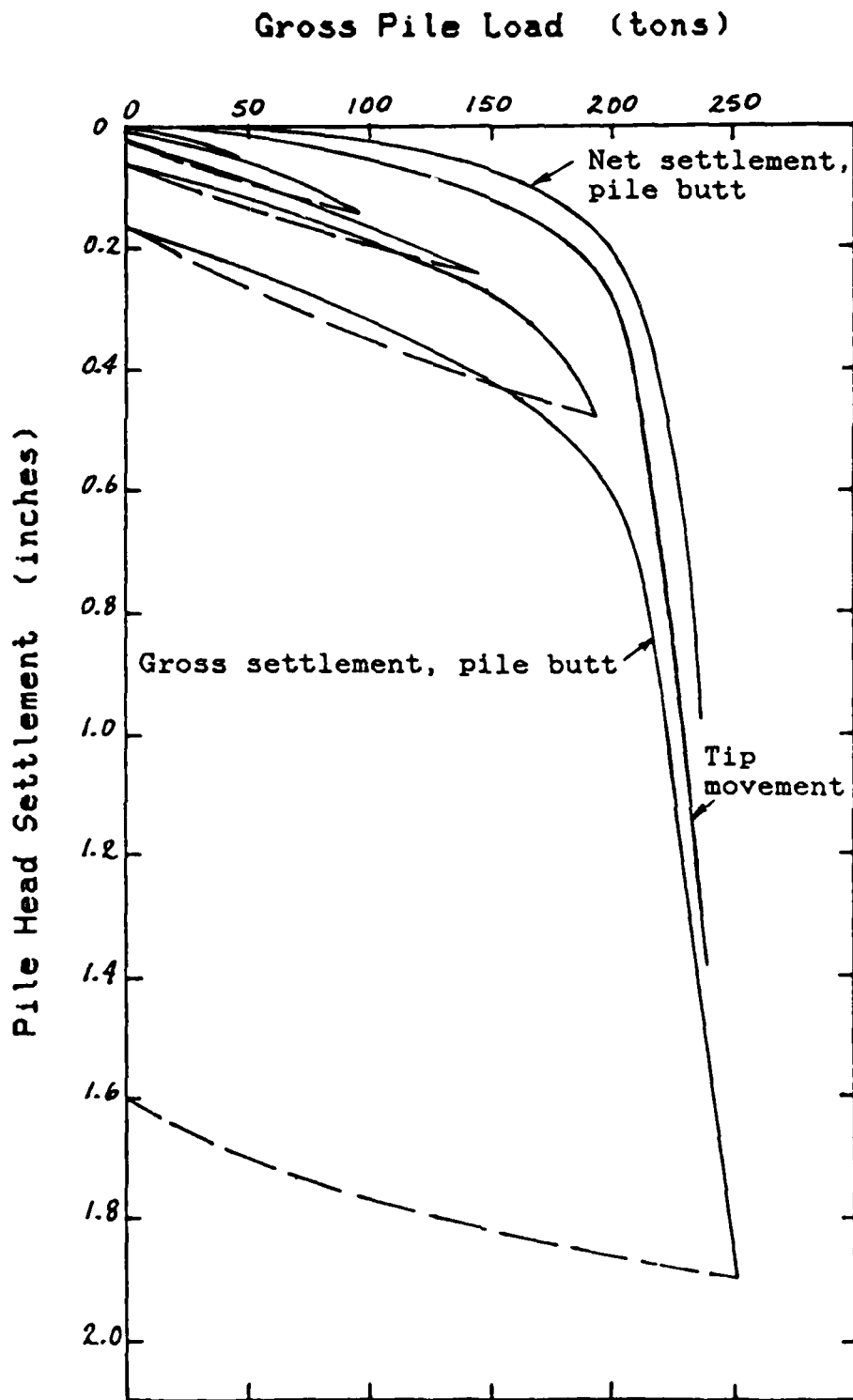

Figure A2. Compression test results - Test Pile 2
Test 1 (16-in. pipe pile)

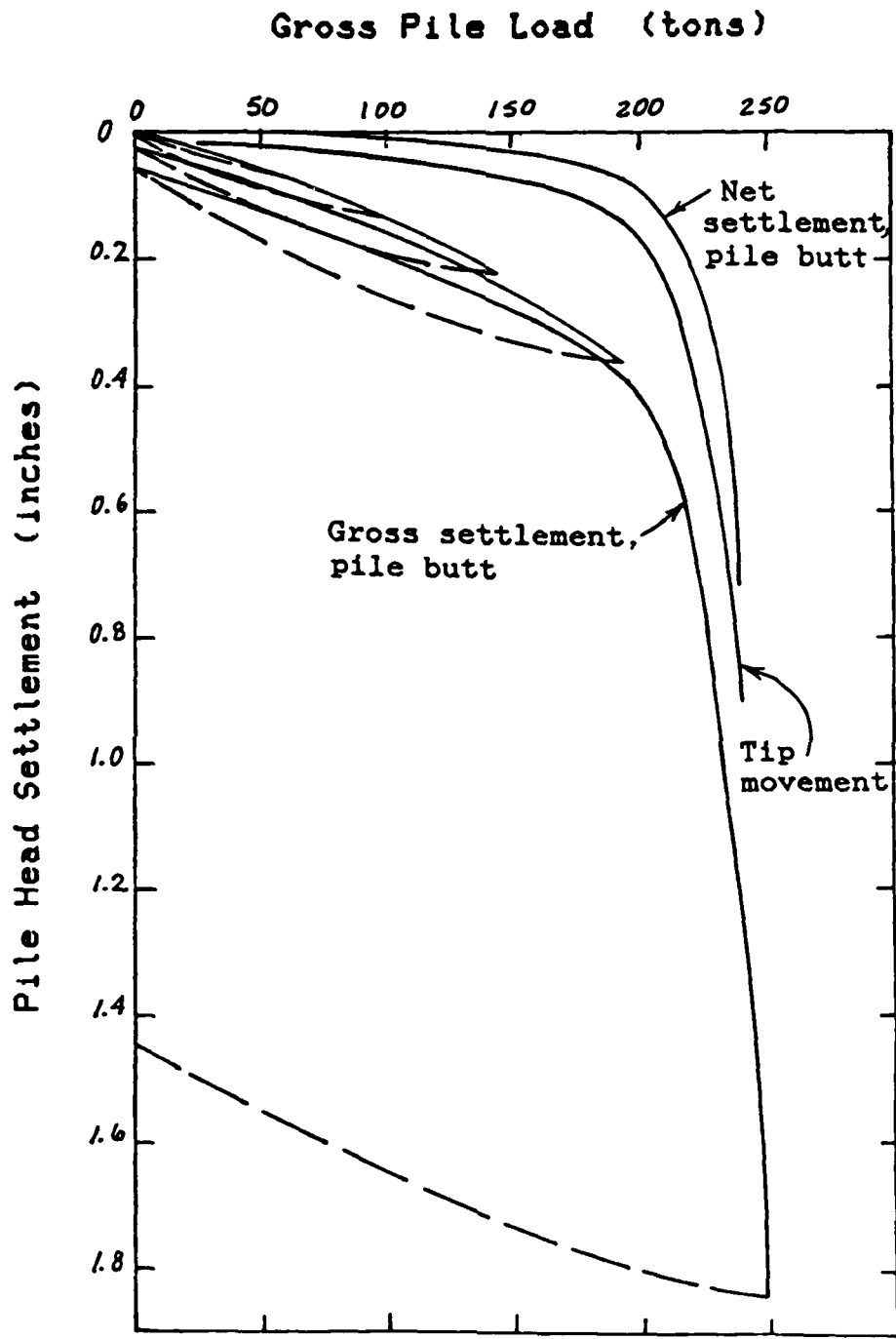

Figure A3. Compression test results - Test Pile 2
Test 2 (16-in. pipe pile)

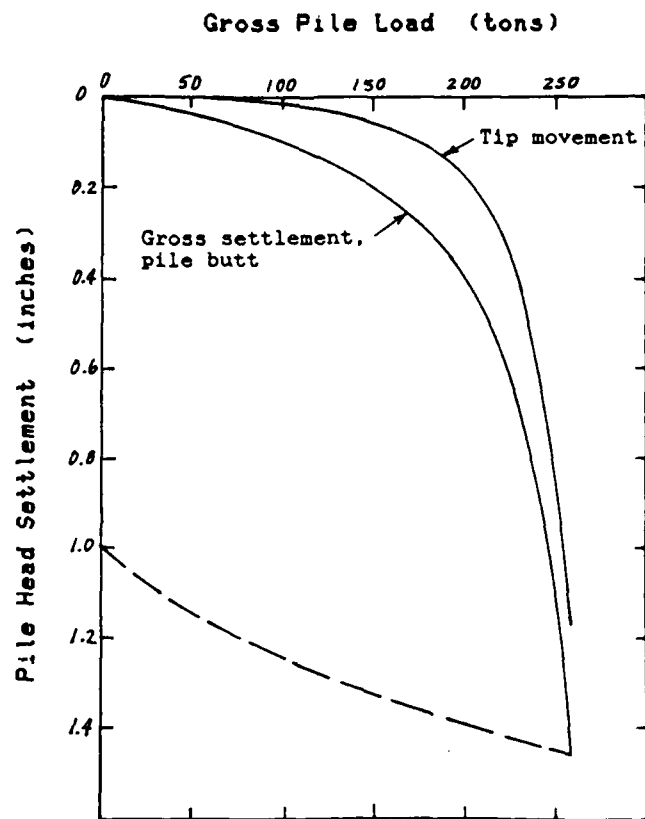

Figure A4. Compression test results - Test Pile 3 (20-in. pipe pile)

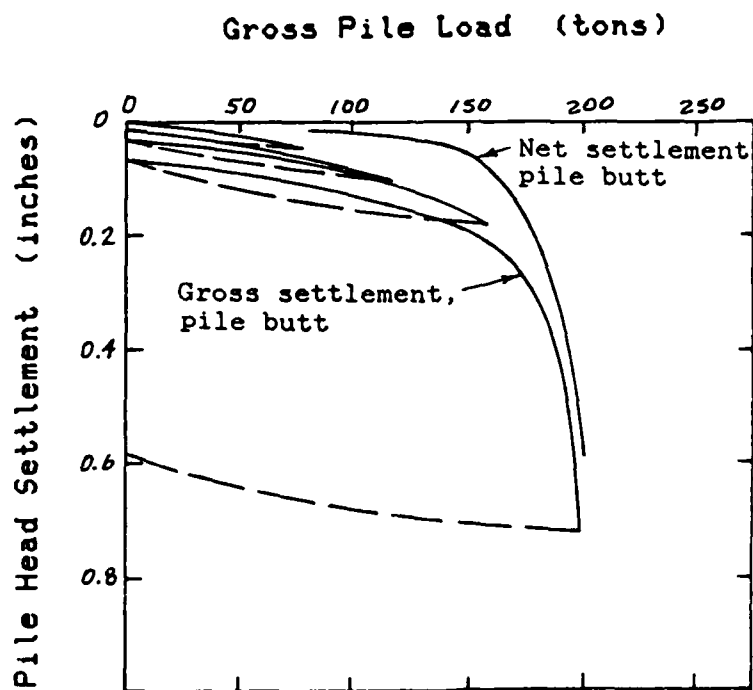

Figure A5. Compression test results - Test Pile 4 (16-in. concrete pile)

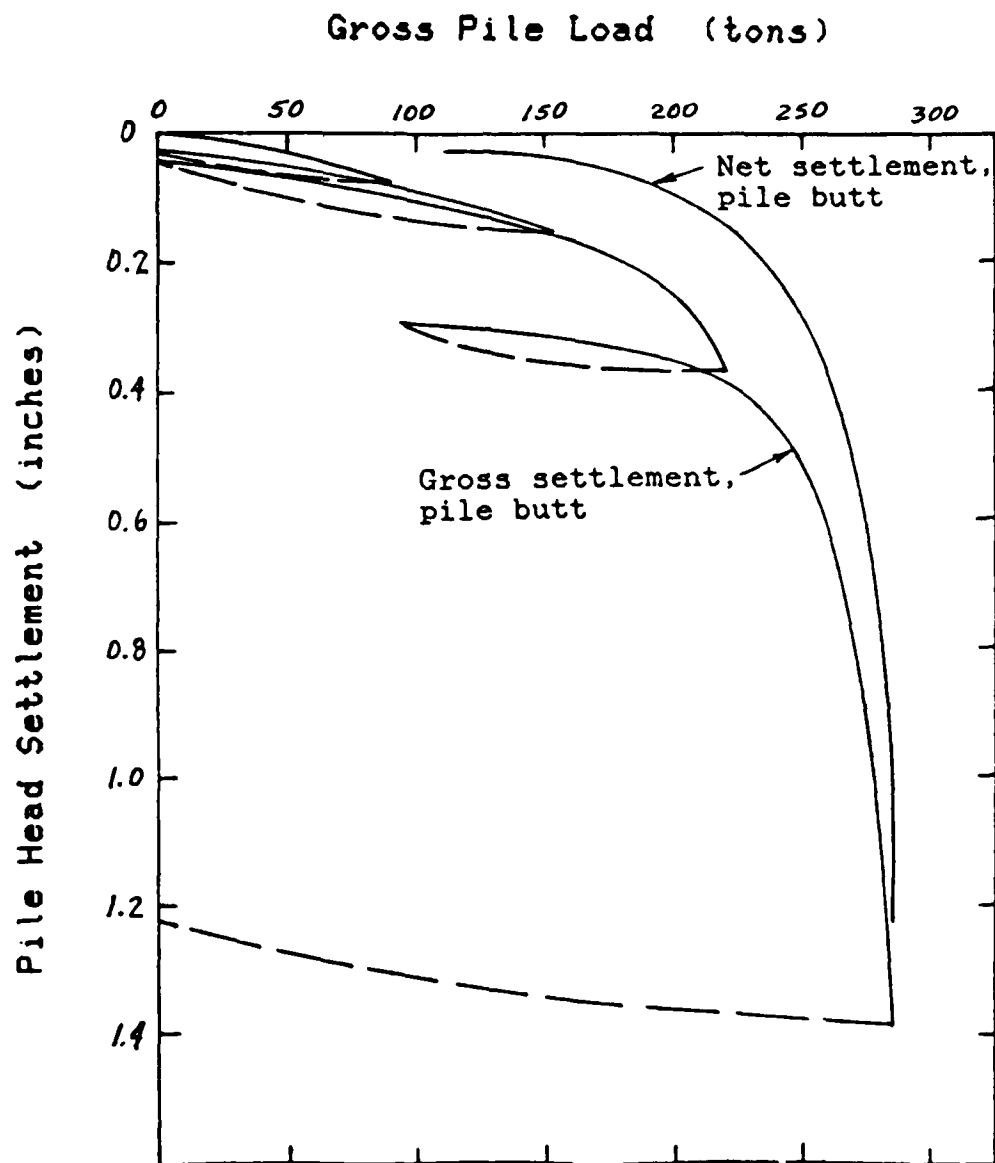

Figure A6. Compression test results - Test Pile 5
(16-in. concrete pile)

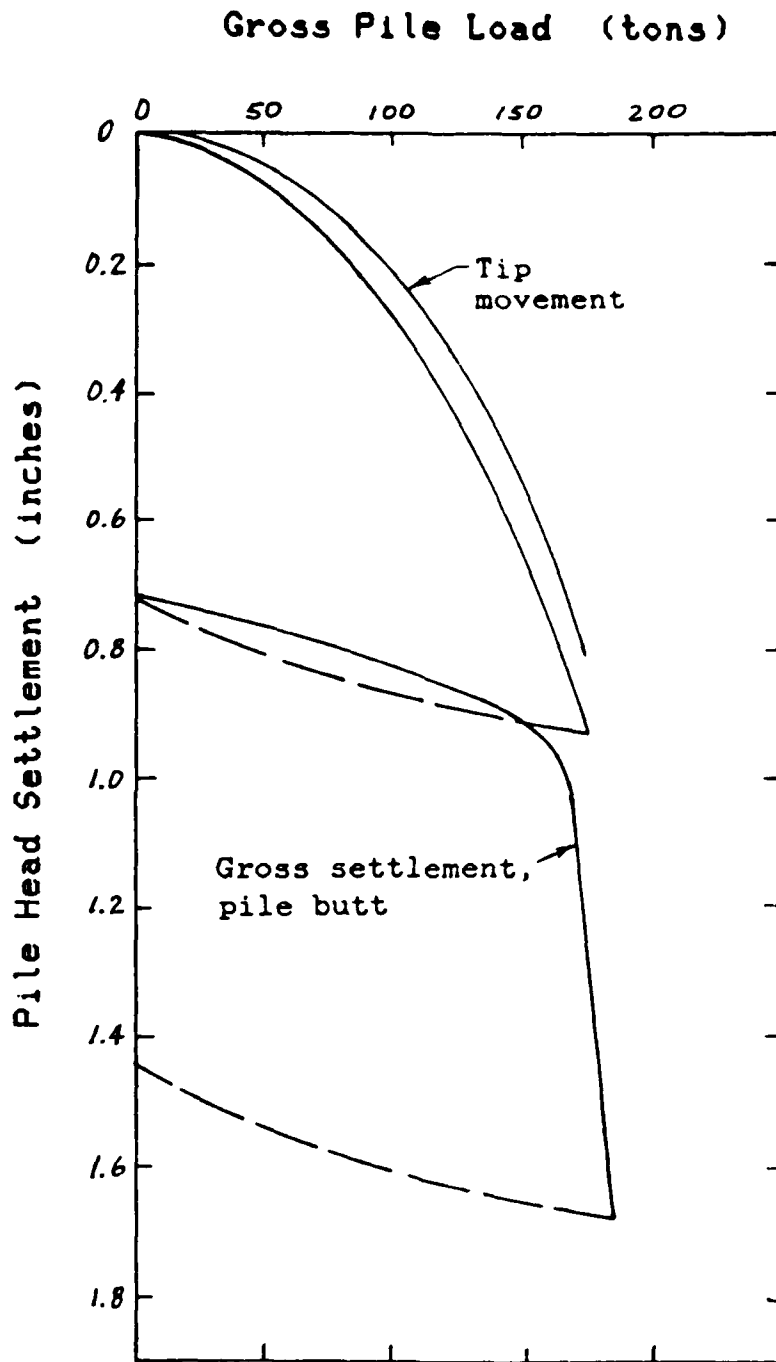

Figure A7. Compression test results - Test Pile 6
(14 BP 73)

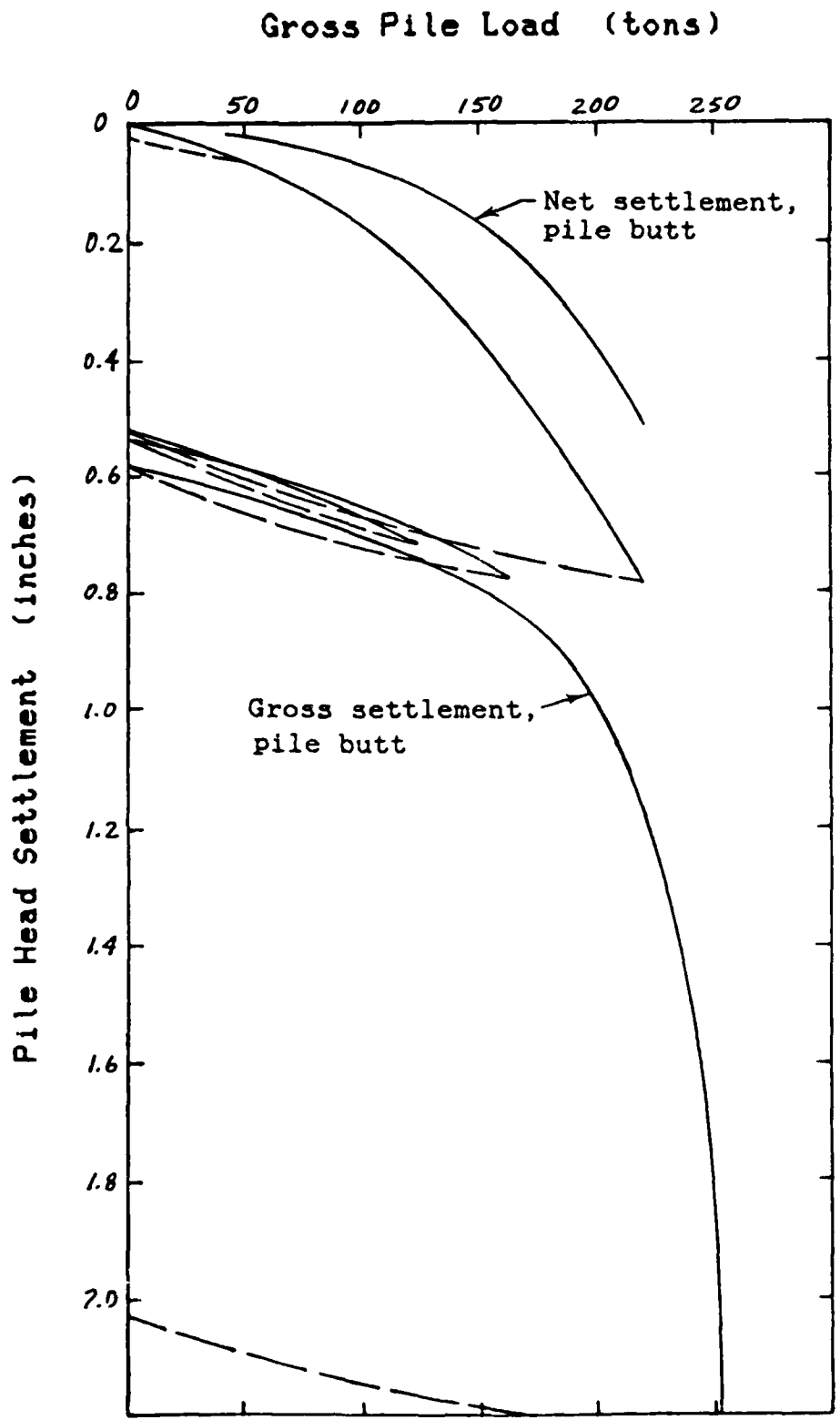

Figure A8. Compression test results - Test Pile 7 (14 BP 73)

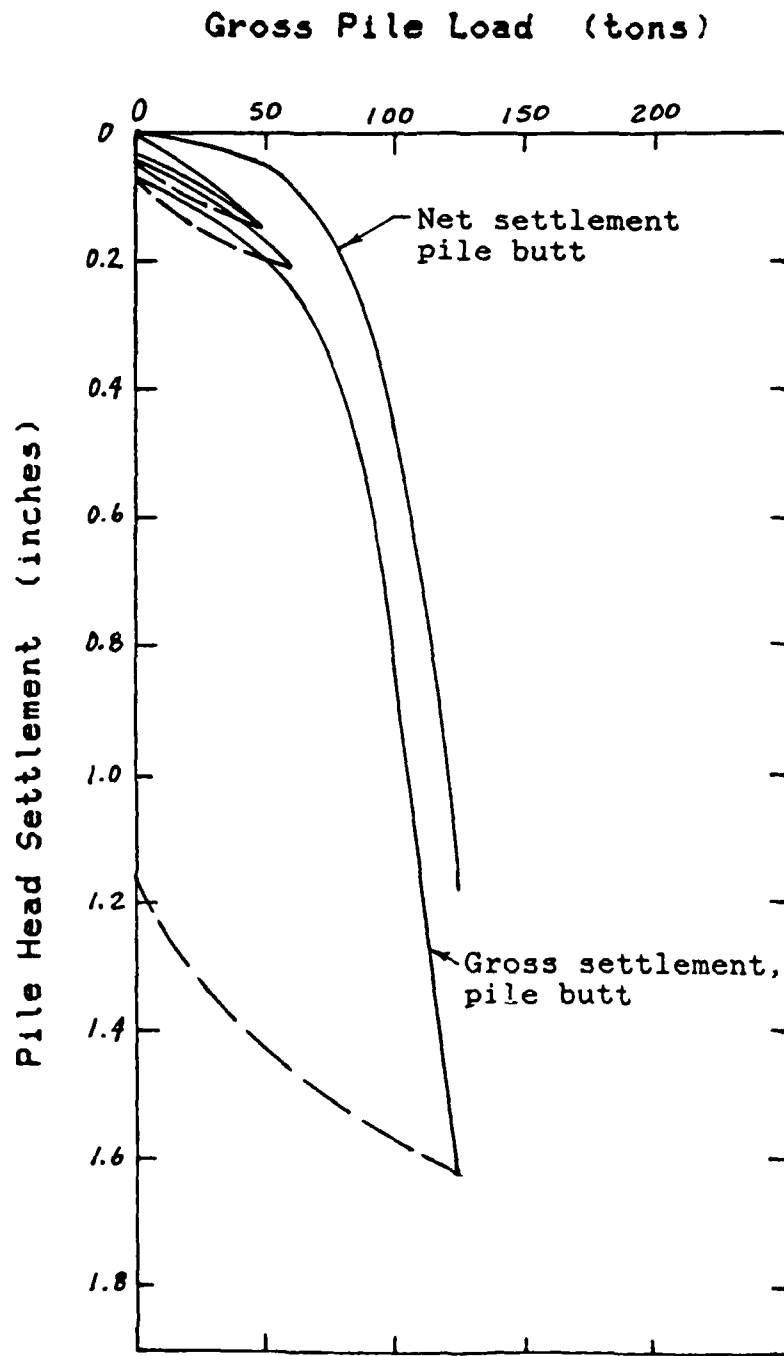

Figure A9. Compression test results - Test Pile 8 (timber pile)

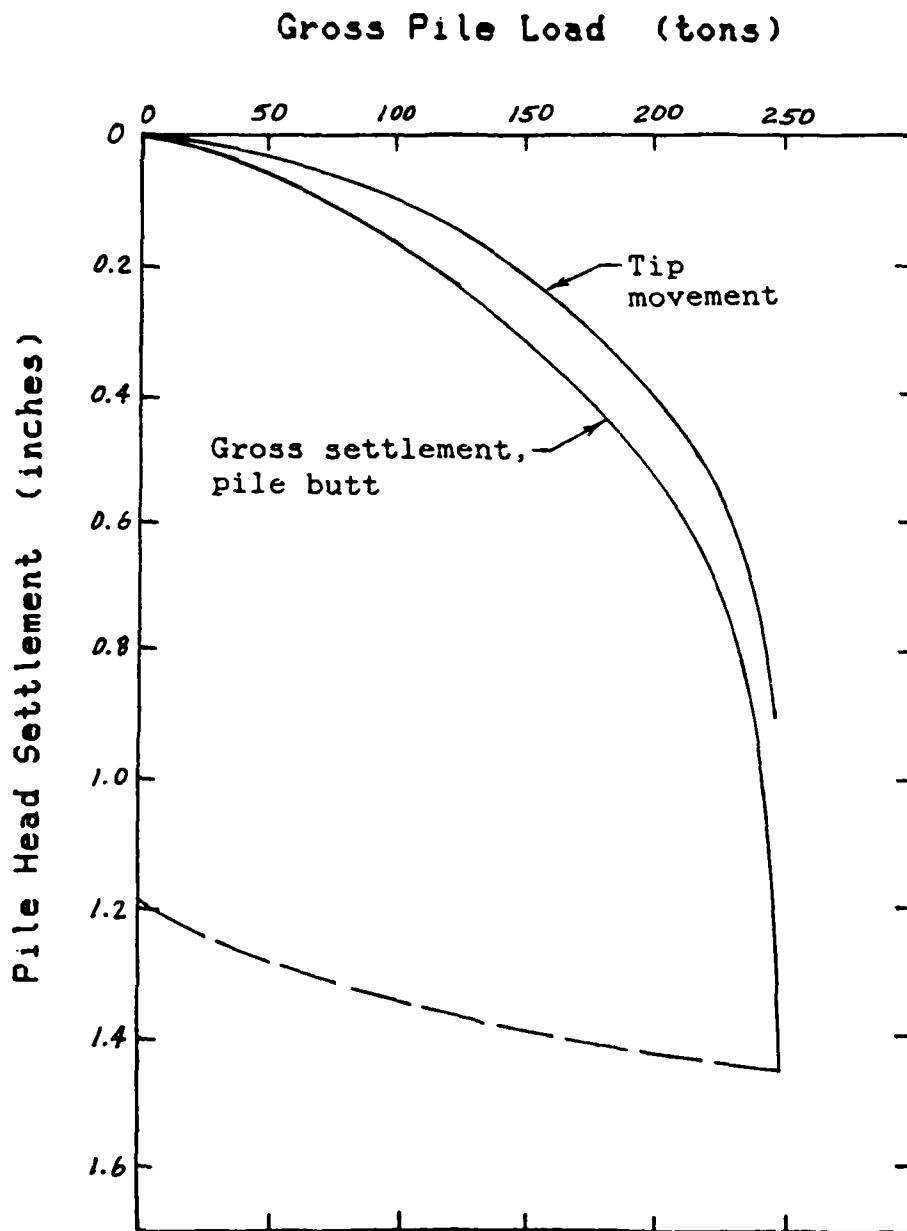

Figure A10. Compression test results - Test Pile 9
(14 BP 73)

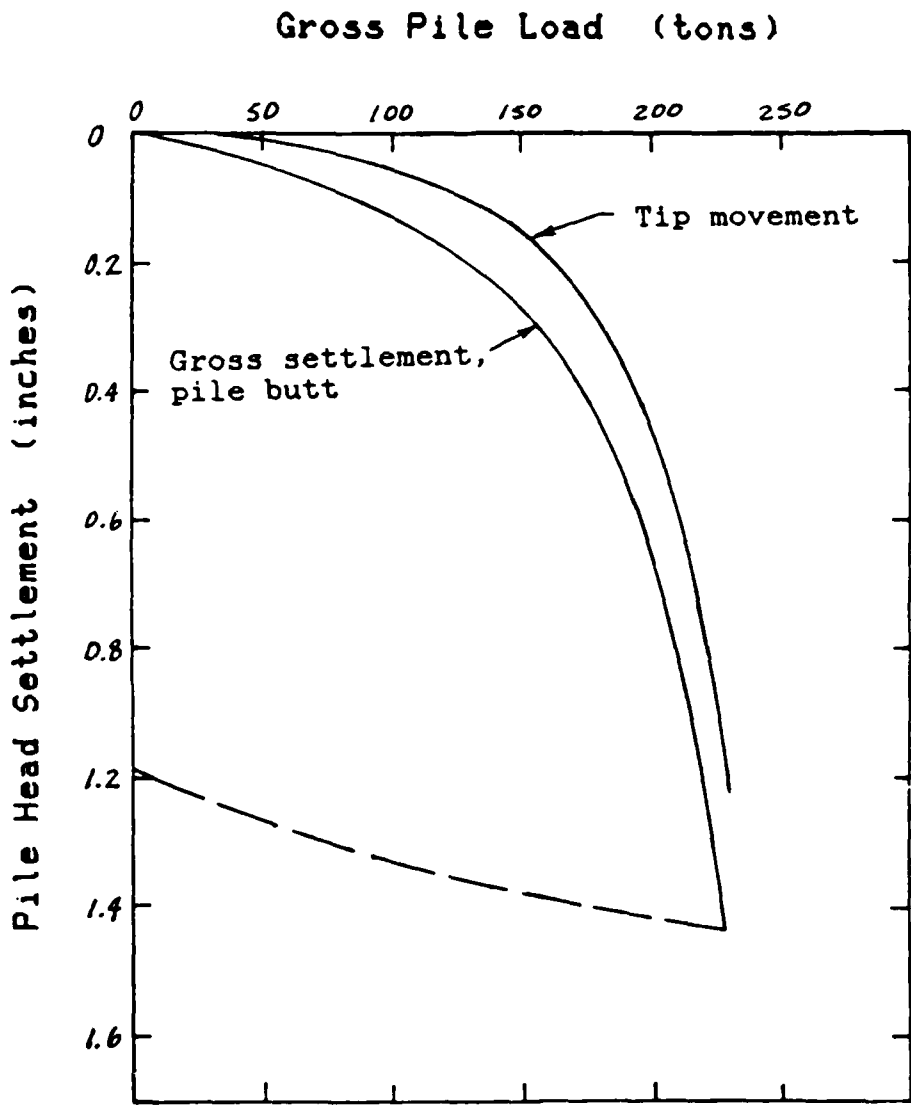

Figure A11. Compression test results- Test Pile 10 (16-in. pipe pile)

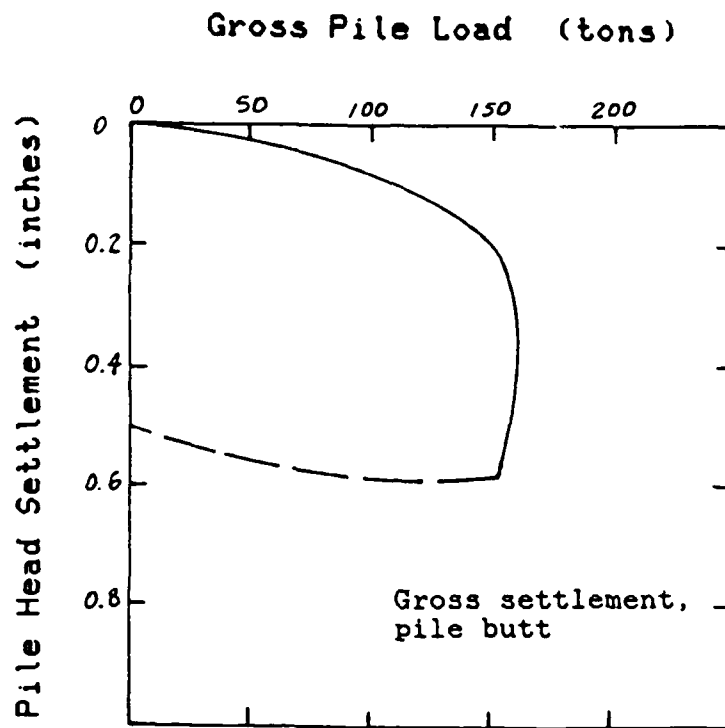

Figure A12. Compression test results - Test Pile 11 (16-in. concrete pile)

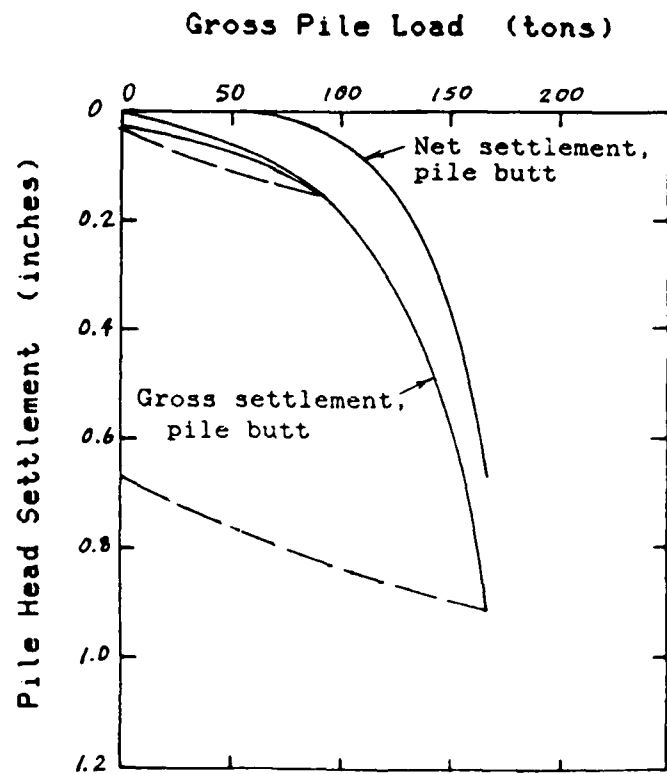

Figure A13. Compression test results - Test Pile 16 (16-in. pipe pile)

APPENDIX B: PILES TESTS,
ARKANSAS RIVER LOCK AND DAM NO. 3

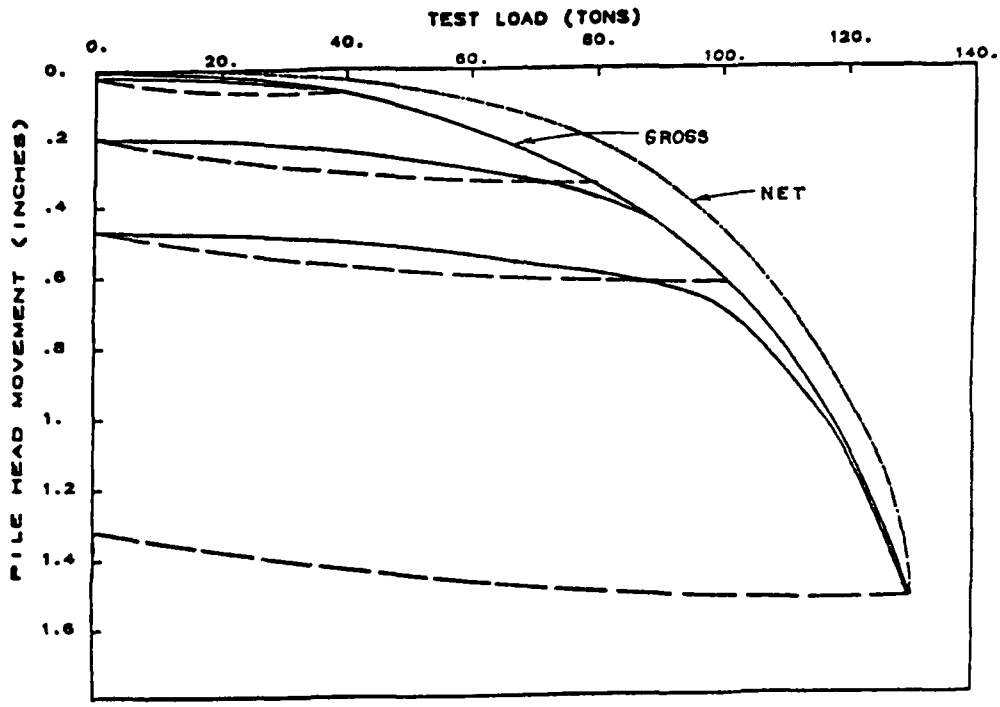

Figure B1. Test Pile 1, compression

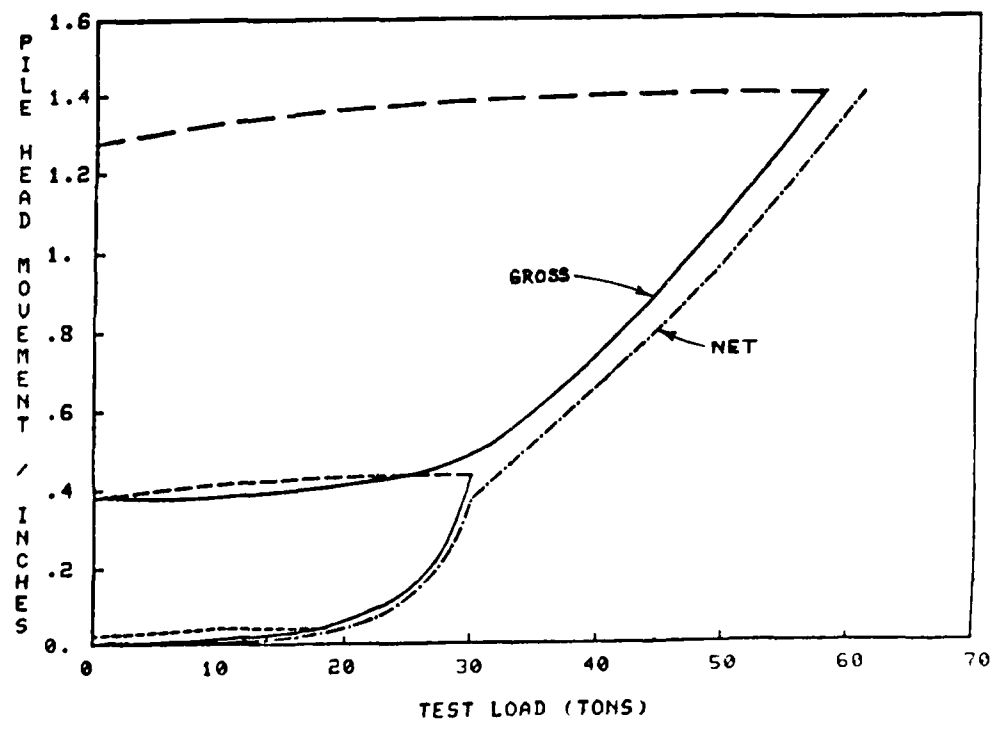

Figure B2. Test Pile 1, tension

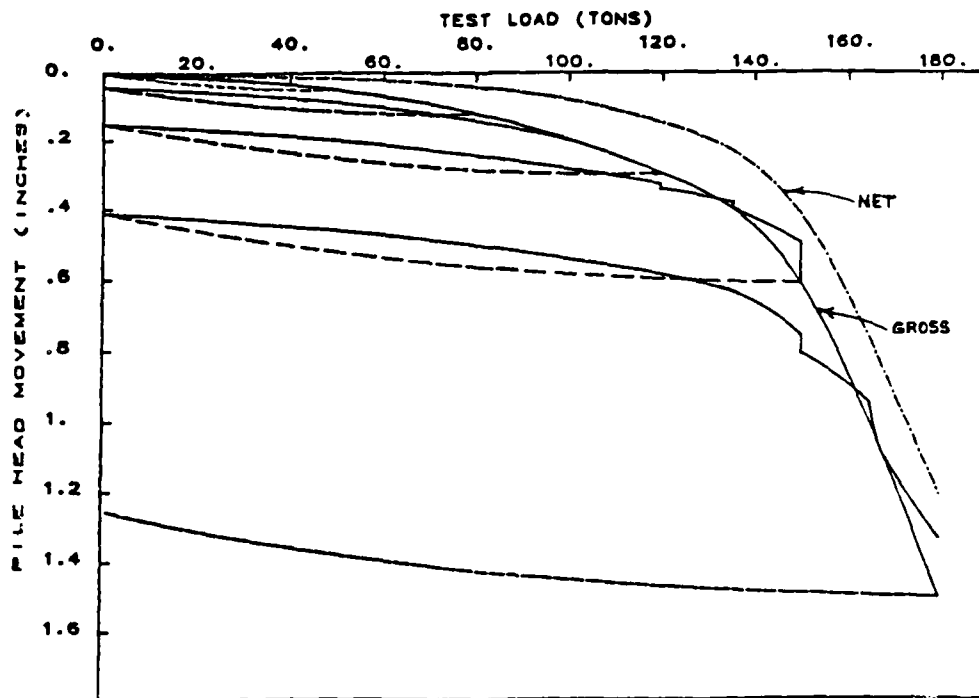

Figure B3. Test Pile 2, compression

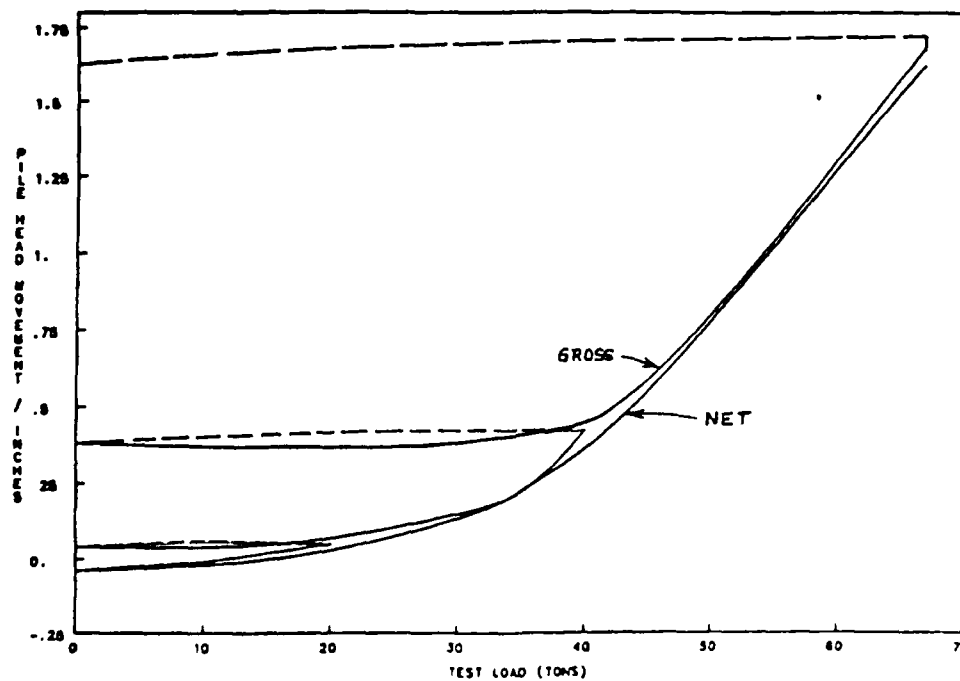

Figure B4. Test Pile 2, tension

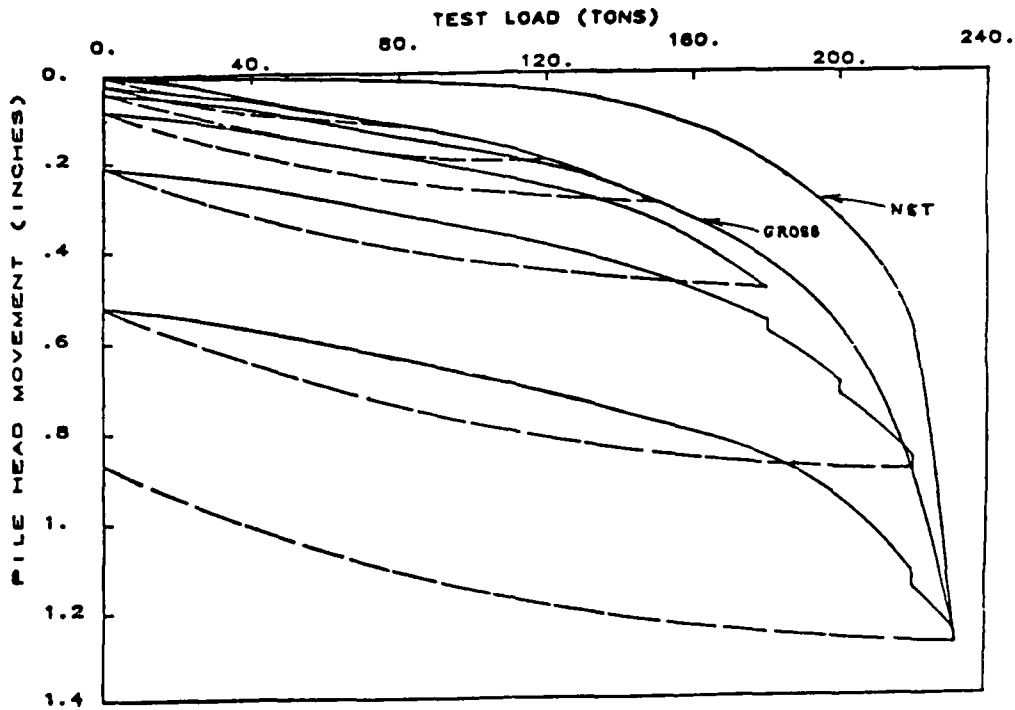

Figure B5. Test Pile 2A, compression

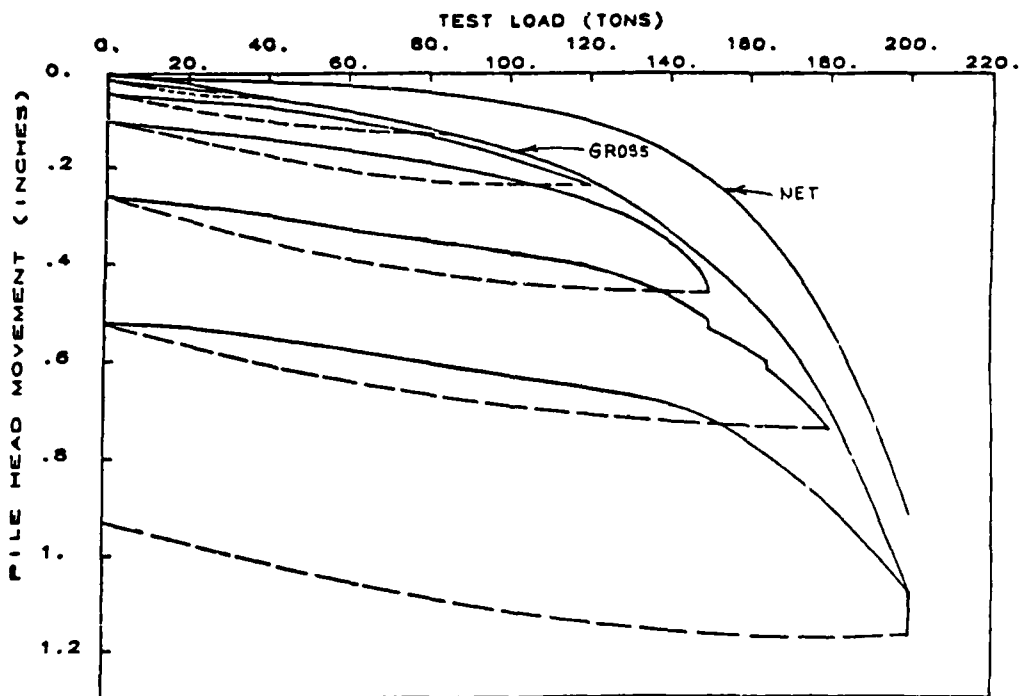

Figure B6. Pile Test 3B, compression

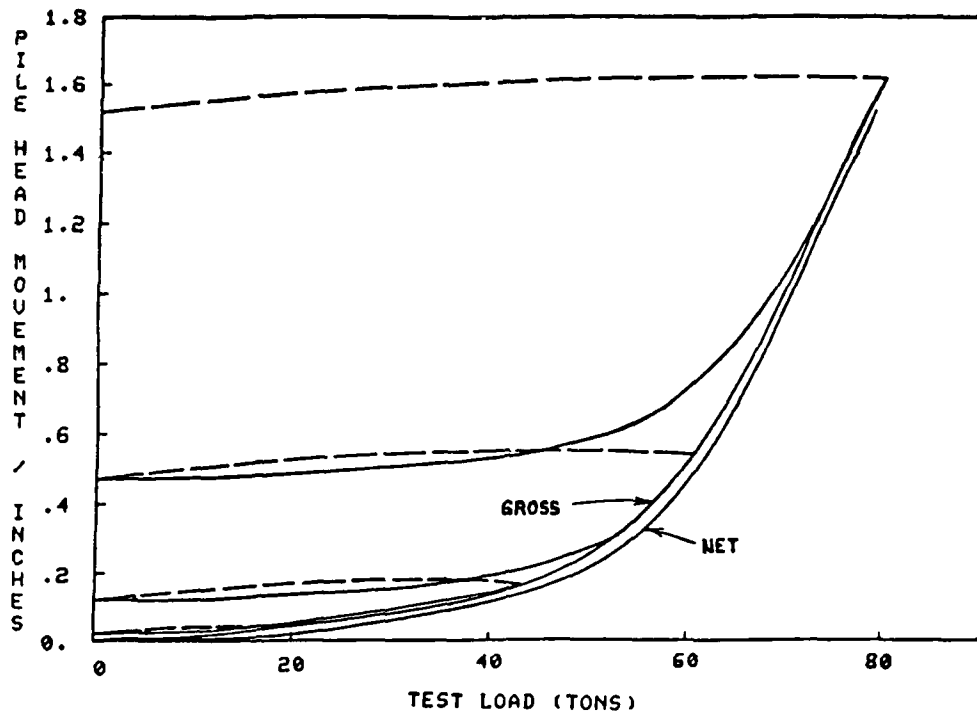

Figure B7. Test Pile 3B, tension

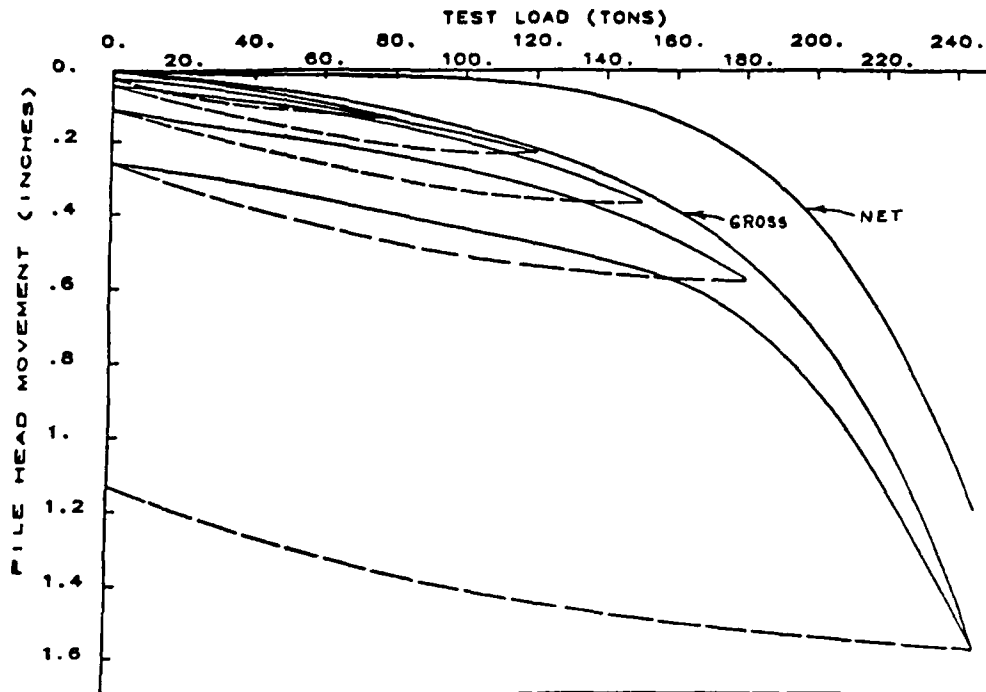

Figure B8. Test Pile 6, compression

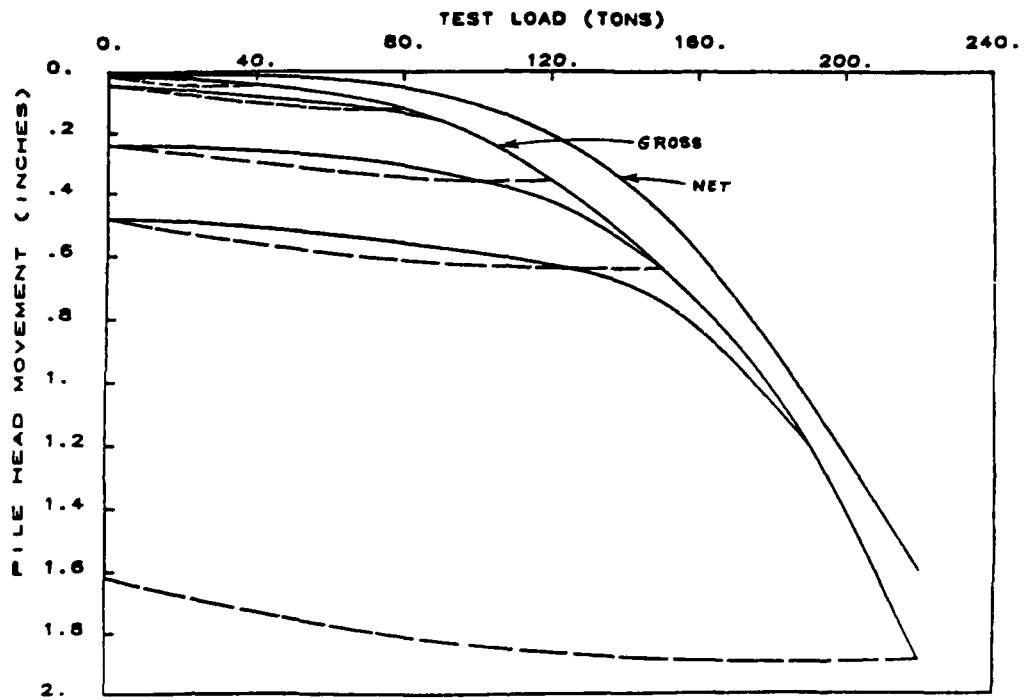

Figure B9. Test Pile 9, compression

END

FILMED

MARCH, 19 88

DTIC