

Resolution Test Chart

AD-A188 835

1

DTIC FILE COPY



ELECTRON TEMPERATURE MEASUREMENTS  
 IN AN ARGON/CESIUM PLASMA DIODE  
 THESIS  
 Michael J. Ward  
 Second Lieutenant, USAF  
 AFIT/GEP/ENP/87D-9

DTIC  
 ELECTE  
 FEB 10 1988  
 S & E D

DEPARTMENT OF THE AIR FORCE  
 AIR UNIVERSITY  
**AIR FORCE INSTITUTE OF TECHNOLOGY**

Wright-Patterson Air Force Base, Ohio

This document has been approved  
 for public release and sale; its  
 distribution is unlimited.

88 2 4 0 4 2

①

AFIT/GEP/ENP/87D-9

ELECTRON TEMPERATURE MEASUREMENTS  
IN AN ARGON/CESIUM PLASMA DIODE

THESIS

Michael J. Ward  
Second Lieutenant, USAF

AFIT/GEP/ENP/87D-9

SEARCHED  
SERIALIZED  
FEB 10 1988  
S E D

Approved for public release; distribution unlimited.

ELECTRON TEMPERATURE MEASUREMENTS  
IN AN ARGON/CESIUM PLASMA DIODE

THESIS

Presented to the Faculty of the School of Engineering  
of the Air Force Institute of Technology

Air University

In Partial Fulfillment of the  
Requirements for the Degree of  
Master of Science in Engineering Physics



Michael J. Ward, B.S.  
Second Lieutenant, USAF

December 1987

Accession For	
NTIS GRA&I	<input checked="" type="checkbox"/>
DTIC TAB	<input type="checkbox"/>
Unannounced	<input type="checkbox"/>
Justification	
By _____	
Distribution/	
Availability Codes	
Dist	Avail and/or Special
A-1	

Approved for public release; distribution unlimited

## Acknowledgements

This study was by no means an individual effort. Instead it represents the commitment and hard work of several individuals. In particular, I thank Dr. William Bailey, my faculty advisor, for his patient effort in assisting me to understand the physics of plasmas and for helping me to address the difficult questions that arose in the course of this study. I also thank Dr. Biswa Ganguly, my laboratory advisor, who provided the conceptual and procedural basis for this study and who was always most willing to help. I owe thanks to Dr. S. Douglas Marcum and Mr. Mark Gieske, both of Miami University at Oxford, OH, for designing, constructing, and trouble-shooting the experimental apparatus and for providing important advice. I extend my gratitude to the the personnel of the Advanced Plasma Research Group, for their expertise and support. I also express my sincere thanks to my family and friends for their prayers and encouragement. But most of all, I wish to acknowledge the LORD, because He has been my strength and my hope through all of this.

Table of Contents

	Page
Acknowledgements . . . . .	ii
List of Figures . . . . .	v
List of Tables . . . . .	vi
Abstract . . . . .	vii
I. Introduction . . . . .	1
Objective . . . . .	1
Background . . . . .	2
II. Theory . . . . .	9
The Rate Equation . . . . .	10
Analysis of Discharge Processes . . . . .	11
Electron Impact Excitation . . . . .	11
Radiative Recombination . . . . .	16
Radiative Losses . . . . .	17
Electron Impact De-Excitation . . . . .	19
Quenching Losses . . . . .	22
Resultant Expression . . . . .	24
III. Experimental Apparatus . . . . .	25
The Diode System . . . . .	25
The Diode Structure . . . . .	25
Discharge Behavior . . . . .	27
The Spectroscopic System . . . . .	29
The Vacuum System . . . . .	32
The Heating System . . . . .	32
IV. Experimental Procedure . . . . .	35
Breaking in the System . . . . .	35
Calibration of Spectrometer . . . . .	35
Spectral Measurements . . . . .	36
Determining Which Transitions to Observe . . . . .	39
V. Data Analysis and Results . . . . .	43
Calculating the Intensity . . . . .	43
Calculations . . . . .	47

VI. Conclusions and Recommendations . . . . .	49
Appendix A: Estimating the Integral in the Calculation of the Average Rate of Electron Impact Excitation . . . . .	52
Appendix B: Plots of G(E) for Argon and Cesium Spectral Emission Data at Various Spatial Locations . . . . .	54
Bibliography . . . . .	61
Vita . . . . .	62

List of Figures

Figure	Page
1 General Discharge Structure . . . . .	3
2 Electron Energy Dist. in Negative Glow . . . . .	5
3 Length of Negative Glow . . . . .	7
4 Cesium I Energy Level Diagram . . . . .	18
5 Diode System . . . . .	26
6 Schematic of Visual Discharge Structure . . . . .	28
7 Spectroscopic System . . . . .	30
8 Vacuum System . . . . .	33
9 Spectral Calibration Curve . . . . .	37
10 Enhancement of $10D_{3/2}$ State . . . . .	42
11 Sample Spectrum 5450-8150 A . . . . .	44
12 Detail of Spectral Intensity Measurements . . . . .	45
13-25 Experimental Results in Graphical Form . . . . .	55-67

List of Tables

Figure		Page
1	Excitation Cross Sections in Argon . . . . .	13
2	Excitation Cross Sections in Cesium . . . . .	14
3	Transition Probabilities/Radiative Loss in Argon	20
4	Transition Probabilities/Radiative Loss in Cesium	21

Abstract

Line intensity measurements in an argon/cesium plasma diode were made at various locations within the discharge, yielding a spatially resolved electron temperature distribution. This device operated at 0.9 Torr argon, 0.04 Torr cesium, and at a current density of  $1.05 \text{ mA/cm}^2$ . Observations of the spectral line intensities of the  $6P \rightarrow nS$  and  $6P \rightarrow nD$  transitions of cesium yielded an average electron temperature of 8200 K throughout most of the discharge region. In contrast, the argon line emission data yields an average electron temperature of 13500 K. The difference between these two measured electron temperatures suggests that the electron energy distribution function is non-Maxwellian under the measured plasma conditions.

ELECTRON TEMPERATURE MEASUREMENTS  
IN AN ARGON/CESIUM PLASMA DIODE

I. Introduction

Objective

Selection of the proper plasma diagnostic is crucial to any examination of plasma phenomena. Hence, as the Advanced Plasma Research Group at the Air Force Wright Aeronautical Laboratories (AFWAL) began a study of the behavior of argon/cesium plasmas, it was first necessary to select and test a diagnostic method. In pursuit of this goal, this present study employs spectral intensity measurements as a means to characterize the electron energy distribution in an argon/cesium diode.

The device examined consisted of two 2.54 cm diameter molybdenum electrodes separated by a 1.8 cm gap. Due to the onset of discharge instabilities at higher gas pressures and current densities, the device was operated at 0.9 Torr argon, 0.04 Torr cesium, and at a current density of 1.05 mA/cm<sup>2</sup>. Due to the small dimension of the inter-electrode gap, insertion of an electrostatic probe for diagnostic purposes would disrupt discharge behavior. For this reason, the non-intrusive character of spectral diagnostics is attractive. Additionally, a spectral analysis yields information of the gas composition. This information is

useful in comparing the relative effects of argon and cesium in the discharge. We now take a closer look at the expected behavior of such a device.

### Background

The primary mechanism by which gas discharges are sustained is release of electrons from the cathode surface due to ion bombardment. The ejected electron creates electron-ion pairs as it moves towards the anode. In turn, the newly created ions are accelerated back to the cathode. When the ion flux at the cathode is sufficient to eject one replacement electron, the ionization process is continued and the discharge is said to be self-maintaining.

A close examination of a gas discharge reveals much more structure than accounted for in the above explanation. As an example, Figure 1 displays the general structure of the gas discharge. The various regions may be broken down as follows:

(A) Aston's dark space is the region in which the electrons are being accelerated by the applied field but do not yet have enough energy to ionize or excite any gas species.

(B) The first cathode layer is the region in which the electrons have acquired sufficient energy to excite. Depending on the structure of the gas atom, several such layers may exist.

(C) The cathode dark space evidences continued

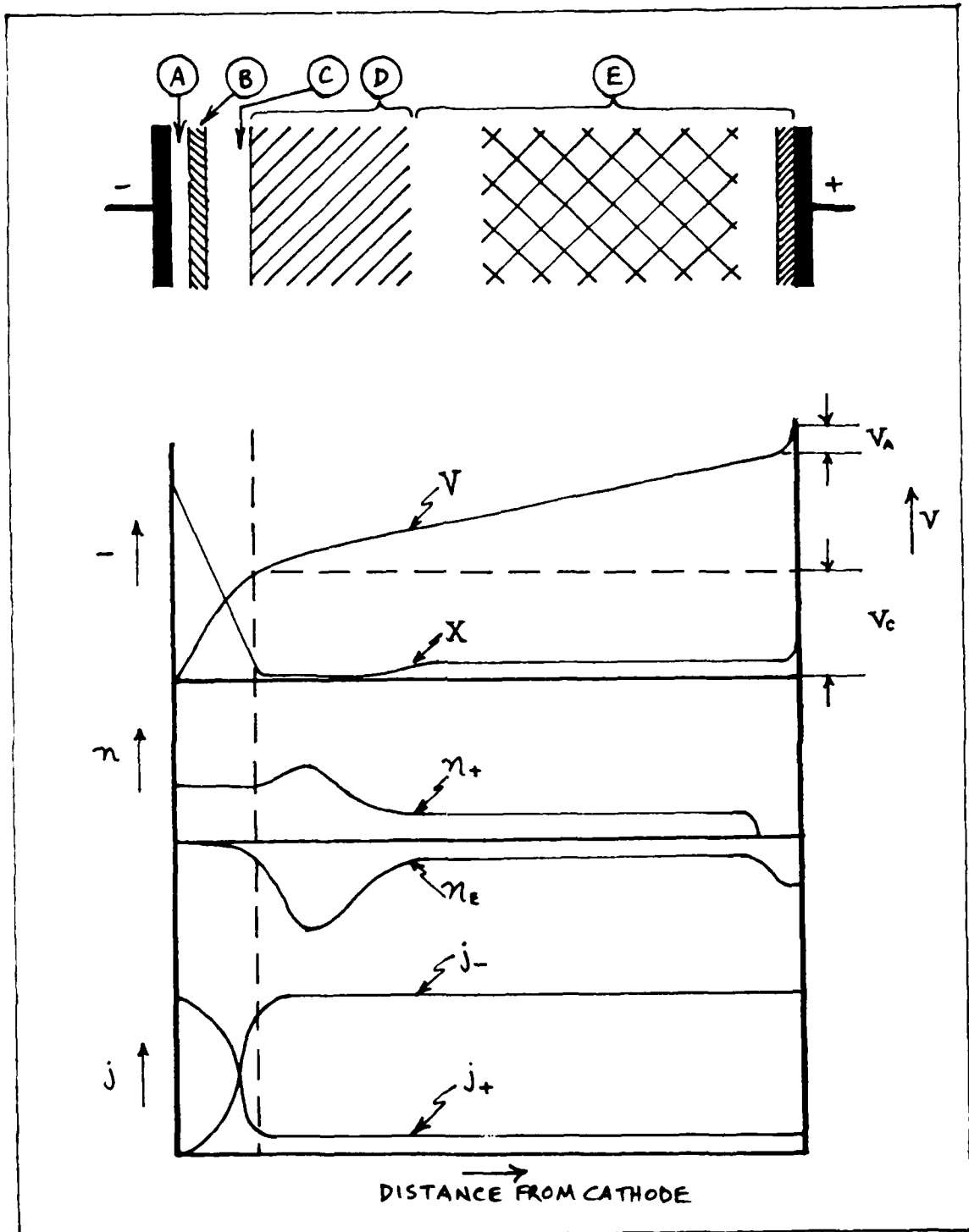

FIG. 1: General features of a glow discharge, where X is the electric field,  $n_+$  and  $n_-$  the space charge densities, and  $j_+$  and  $j_-$  the current densities. (Ref. 1:218)

acceleration of the electrons. At this point they have surpassed the excitation energy and so ionization becomes the dominant process. As the electrons near the far boundary of this region, they have experienced nearly the entire cathode fall voltage, thereby giving them beam-like properties.

(D) In the negative glow, ionization processes continue but there are also sufficient numbers of slower electrons to initiate excitation as well. This highly non-equilibrium region marks the transition from a beam-like distribution to a thermalized distribution. Figure 2 displays the shift of the electron energy distribution from higher to lower energies as the electrons penetrate further into the negative glow region. However, one notes that if the peaks of these distributions can be described by a characteristic temperature, then the negative glow has two groups of electrons--a "fast" beam-like group, which is characterized by a large electron temperature, and a "slow" thermalized group, which is characterized by a smaller electron temperature.

By operating the discharge in argon (threshold energy  $>13$  eV) and cesium (threshold energy  $<1$  eV) we might sample both electron groups. Argon will only be sensitive to the fast electrons while cesium is more likely to interact with the slow electrons. Therefore an analysis of the argon spectrum might yield a different electron temperature than measured by an analysis of the cesium spectrum.

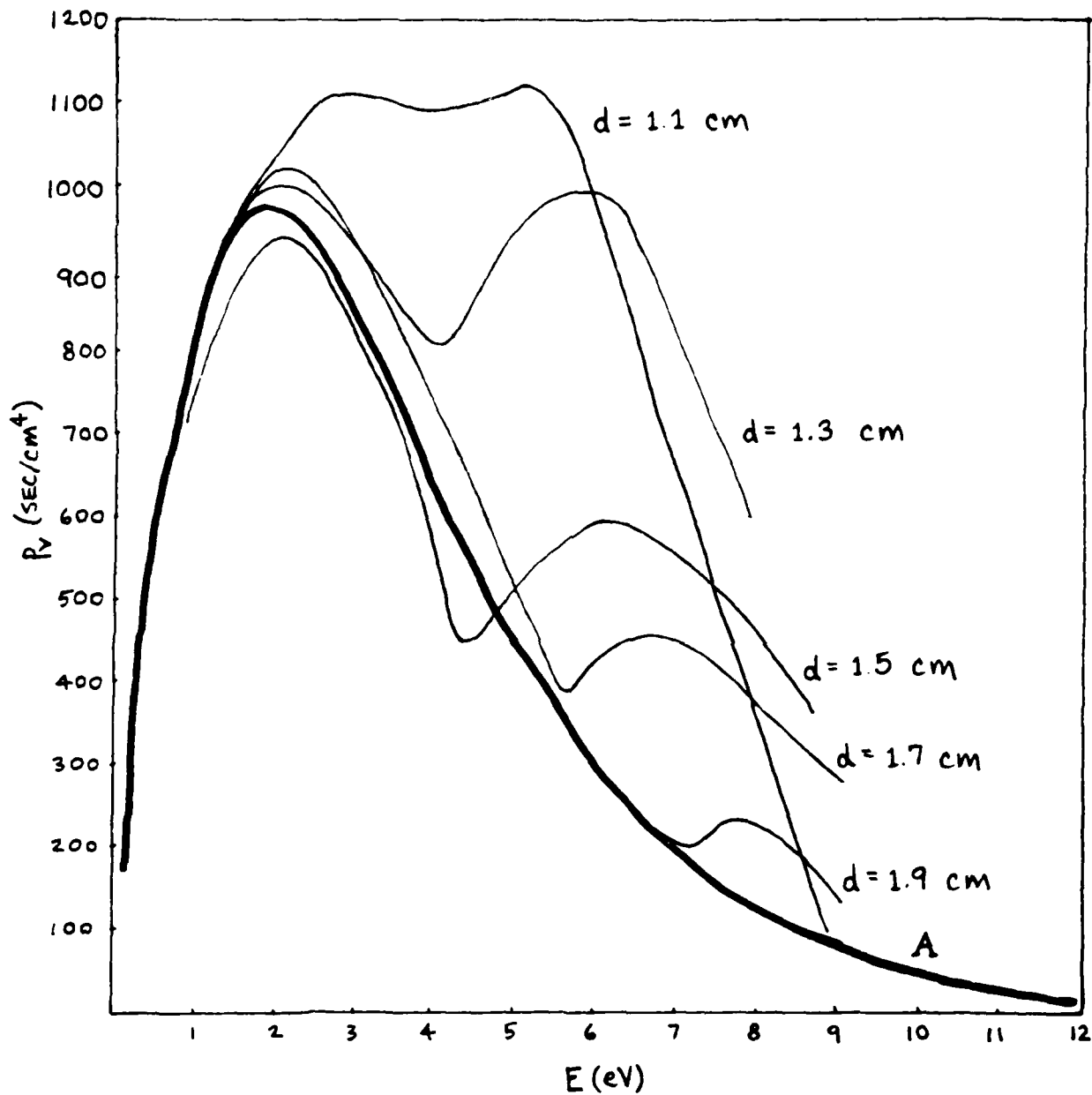

FIG. 2: Electron velocity distribution in the negative glow and Faraday dark space of a neon discharge operating at a current of 1.8 A, with a tube diameter of 2.8 cm, and a pressure of 4.7 Torr. Curve "A" is a Maxwellian which represents the thermalized electrons.  $d$  is the distance from the cathode. (Ref. 2:207)

In order to establish relevant scale lengths for the discharge sheath structure and relate these to the present discharge geometry, we review the work of Brewer and Westhaver (Ref. 3:779). They measured the lengths of the negative glow region in various gases, for a variety of pressures and cathode fall voltages. Their results are shown in Figure 3. Examination of the argon curve for a cathode fall voltage of 200 volts establishes the length of the negative glow to be 1 cm. Considering the dimensions of the device used in this study, we expect to be dealing with an obstructed discharge (Ref. 1:234). The highly non-equilibrium and beam-like structure of the electron energy distribution should be reflected in the spectroscopic observations.

(E) If the electrode separation is larger than the sheath dimensions, a positive column will be formed. However, since the gap is nearly the same size as the expected length of the negative glow, it is doubtful that the remaining discharge regions would be established.

#### Order of Presentation

Having discussed general discharge behavior, Chapter II of this report examines the theoretical framework around which the spectral diagnosis of such a discharge is built. This consists of a detailed comparison of the various discharge processes which results in the derivation of a relationship between spectral intensity and the electron temperature. Chapter III describes the experimental

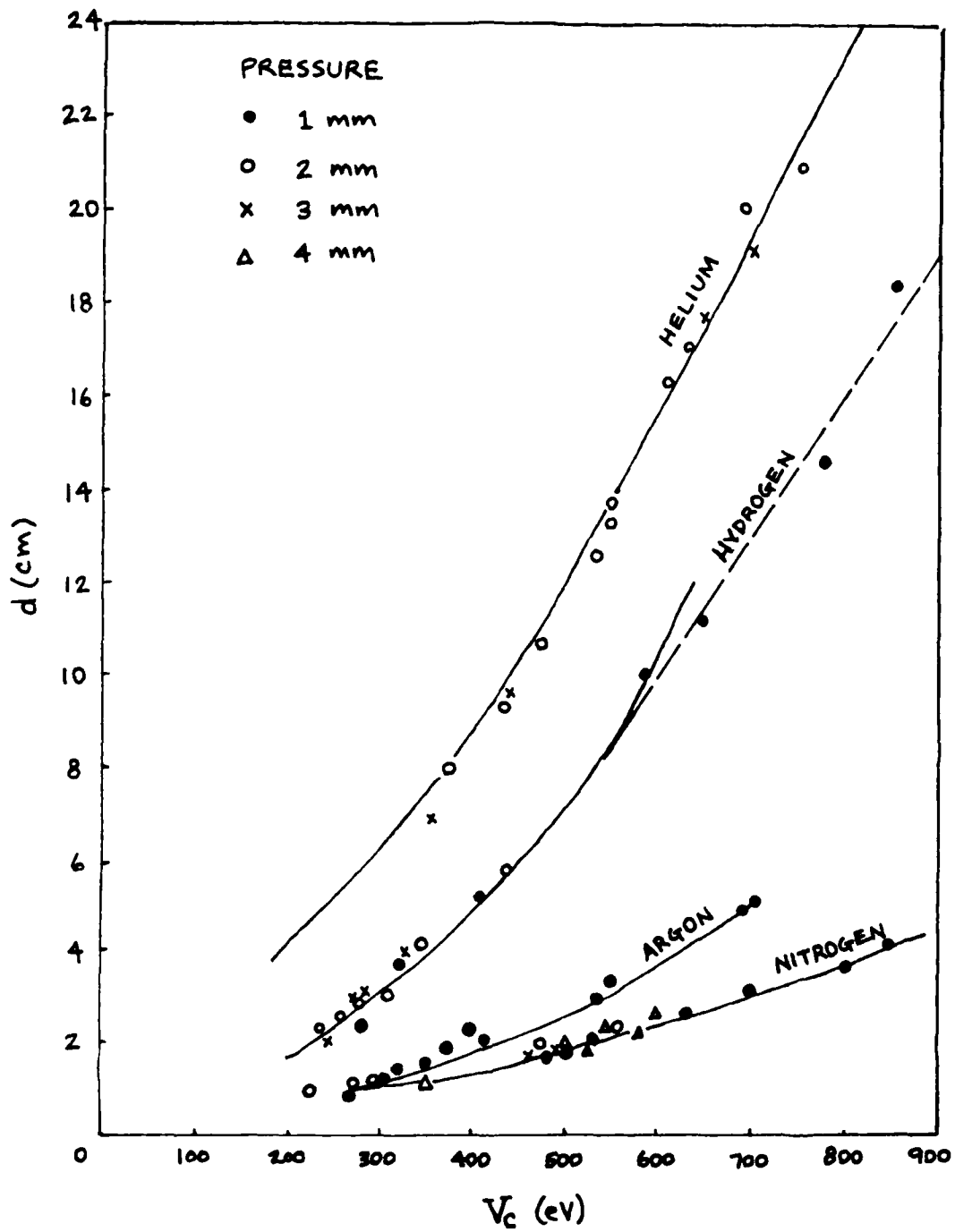

FIG. 3: Length of negative glow for various values of the cathode fall in various gases.  
(Ref. 3:779)

apparatus and Chapter IV explains the method by which this apparatus was used to gather data. A description of the data analysis and quantifiable results is presented in Chapter V, from which conclusions and recommendations are made in Chapter VI.

## II. Theory of Extracting the Electron Temperature From Line Intensity Measurements

The electron temperature,  $T_e$ , is a measure of the average kinetic energy of the electrons present in a discharge. If the dominant form of excitation in the discharge is electron impact and if radiation is the primary decay mechanism, then we see that the excited state populations are linked to the energy distribution,  $f(E)$ , of free electrons. If the distribution is a Maxwellian that peaks near  $E=E_U$  and has a smaller value at  $E=E_L$ , then one would expect the electron impact excitation of the upper level to be enhanced over the excitation of the lower level. Therefore, the radiative decay of these states should reveal a similar enhancement of the intensity of those lines which are characteristic of  $E_U$  over those which are characteristic of  $E_L$ . A measurement of the line intensities will then be a direct means of probing the electron energies and the corresponding electron temperatures.

But by neglecting the other mechanisms of excitation and decay, this description has been overly simplified. The following discussion remedies this situation by analyzing the various processes which alter the population of state  $E_U$ . These are incorporated into a rate equation, and the significance of each term is examined. This examination reveals that the assumption regarding the dominant discharge processes is well justified for the discharge which was studied. Solving the resultant equation in a steady state

relates measurement of spectral intensities to a value for  $T_e$ .

### The Rate Equation

The mechanisms by which the upper state can be populated include electron impact excitation and recombination. Therefore the upper state is populated according to the rate  $(dN_u/dt)_+$ , where

$$\left(\frac{dN_u}{dt}\right)_+ = \langle R_{exc} \rangle n_0 n_e + \langle R_{rec} \rangle n_+ n_e \quad (1)$$

$\langle R_{exc} \rangle$  is the frequency of electron impact excitation, and  $\langle R_{rec} \rangle$  is the frequency of the recombination of free electrons.  $n_0$ ,  $n_+$ , and  $n_e$  are respectively the neutral, ion, and electron number densities.

The population of the excited state is depleted by radiative losses, electron collision de-excitation, and quenching collisions with heavy neutrals at the rate  $(dN_u/dt)_-$ , which is given by

$$\left(\frac{dN_u}{dt}\right)_- = N_u (A_{u1} + A_{u2} + A_{u3} + \dots) + \langle R_Q \rangle n_0 n_e + \langle R_{dex} \rangle n_e N_u \quad (2)$$

where  $A_{ul}$  is the spontaneous transition rate coefficient from a state with energy  $E_u$  to some lower state with energy  $E_l$ ,  $\langle R_Q \rangle$  is quenching collision frequency, and  $\langle R_{dex} \rangle$  is the frequency of electron impact de-excitation.

In a steady-state,  $(dN_u/dt)_+ = (dN_u/dt)_-$ . Using this condition and Equations (1) and (2),  $N_u$  is solved for:

$$N_u = \frac{\langle R_{EXC} \rangle n_0 n_E + \langle R_{REC} \rangle n + n_E}{\sum_l A_{ul} + \langle R_Q \rangle n_0 + \langle R_{DEXC} \rangle n_E} \quad (3)$$

The intensity  $I_{uL}$  of the transition from state  $u$  to state  $l$  is expressed by

$$I_{uL} = N_u A_{uL} (E_u - E_L) \quad (4)$$

Hence, Equation (3) may be rewritten as

$$I_{uL} = N_u A_{uL} (E_u - E_L) \frac{\langle R_{EXC} \rangle n_0 n_E + \langle R_{REC} \rangle n + n_E}{\sum_l A_{ul} + \langle R_Q \rangle n_0 + \langle R_{DEXC} \rangle n_E} \quad (5)$$

Now take a closer look at each of the terms in this equation.

### Analysis of Discharge Processes

Electron Impact Excitation. One of the means of populating an excited state is by electron impact excitation from lower lying levels. In Equation (5), this contribution is expressed as  $\langle R_{EXC} \rangle n_0 n_E$ .  $\langle R_{EXC} \rangle$  is obtained by integrating the product of the distribution function  $f(v)$  and  $R_{EXC}$  ( $=Q_{EXC} v$ ) over all electron velocities, where  $Q_{EXC}$  is the excitation cross section:

$$\langle R_{EXC} \rangle = \int_0^{\infty} Q_{EXC}(\vec{v}) \cdot \vec{v} \cdot f(\vec{v}) d\vec{v} \quad (6)$$

Zapesochnyi, et al., measured excitation cross-sections in both argon (Ref. 4:291) and cesium (Refs. 5:421, 6:6,

7:504). Tables I and II tabulate the maximum value of the cross section,  $Q_{MAX}$ , and the corresponding energy,  $E_{MAX}$ . To a good approximation, the excitation cross section varies linearly near the threshold energy. Hence, in the following treatment,  $Q_{EXC}(E)$  is modeled as a linear function.

Upon viewing the cesium cross section data, one notes that  $Q_{MAX}$  is reached within only 1 eV of threshold. Since the cross section falls as  $\sim 1/E$  for electron energies greater than 1 eV, the linear approximation is no longer valid. However, we expect the thermal electrons, to which cesium is most sensitive, to have energies of less than 1 eV. We will see that the results of this study satisfy this expectation.

Literature values for the excitation cross section for the  $4D_{1/2}$  and  $7S_{3/2}$  states in argon were not found. Therefore, an analytical model developed by Drawin (Ref. 8) was employed in calculating the cross section of electron impact excitation,  $Q_{EXC}(E)$  from lower state  $l$  to upper state  $u$ . The formula for this model is expressed as

$$Q_{UL}(E) = 4\pi a_0^2 \left(\frac{E_{H+}}{E_{UL}}\right)^2 f_{UL} B_1 \frac{\left(\frac{E}{E_u} - 1\right)}{\left(\frac{E}{E_u}\right)^2} \ln\left(1.25 B_2 \frac{E}{E_u}\right) \quad (7)$$

where  $a_0$  is the Bohr radius,  $E_{H+}$  is the ionization energy of hydrogen,  $f_{UL}$  is the absorption oscillator strength,  $B_1$  and  $B_2$  are adjustable constants of order unity (Ref. 9:27).  $B_1$  and  $B_2$  were determined using partial argon cross-section data from Petersen and Allen (Ref. 10:6068),

Table I

Maximum Values of Low-Energy Electron Impact Excitation  
Cross Sections for Selected Transitions in Argon\*

<u>Level</u>	<u><math>E_{TH}</math> (eV)</u>	<u><math>E_{MAX}</math> (eV)</u>	<u><math>Q_{MAX}</math> (<math>10^{-19}</math> cm<sup>2</sup>)</u>
7S <sub>3/2</sub> <sup>o</sup>	15.17	(58)**	(79.7)**
4D <sub>1/2</sub> <sup>o</sup>	14.71	(58)**	(78.2)**
4P' <sub>1/2</sub>	13.32	24	57.1
4P' <sub>3/2</sub>	13.29	21	84.4
4P <sub>1/2</sub>	13.27	20.6	46.7
4P <sub>3/2</sub>	13.16	22.5	129.8
4P <sub>3/2</sub>	13.15	21	78.0
4P <sub>5/2</sub>	13.07	22	136

\* (Ref. 4:291)

\*\* Calculated using Drawin's formula (Ref 8)

Table II

Maximum Values of Low-Energy Electron Impact Excitation  
Cross Sections for Selected Transitions in Cesium\*

<u>Level</u>	<u><math>E_{TH}</math> (eV)</u>	<u><math>E_{max}</math> (eV)</u>	<u><math>Q_{max}</math> (<math>10^{-16}</math> cm<sup>2</sup>)</u>
9D <sub>3/2</sub>	3.8	4.25	4.0
9S <sub>1/2</sub>	3.5	4.0	7.6
9S <sub>1/2</sub>	3.5	4.25	15.3
7D <sub>3/2</sub>	3.0	4.0	19.5
7D <sub>5/2</sub>	3.2	4.0	34.0
8S <sub>1/2</sub>	3.0	3.5	19.0
8S <sub>1/2</sub>	3.0	3.6	39.0

\* (Ref. 7:504)

and argon oscillator strength data from Wiese, et al. (Ref. 11:192). This analysis yielded excitation cross section data for the ground state ( $3P_0$ ) to  $4D_{1/2}^o$  and  $7S_{3/2}^o$  transitions. These values are expressed parenthetically in Table I.

Modeling the excitation cross-section as a positive ramp function, we approximate  $Q_{EXC}(E)$  as

$$Q_{EXC}(E) \approx M(E - E_{TH}) \quad (8)$$

where  $E_{TH}$  is the threshold energy and  $M$  is the slope, given by

$$M = \frac{Q_{MAX}}{E_{MAX} - E_{TH}} \quad (9)$$

Therefore

$$Q(E) = Q_{MAX} \left( \frac{E - E_{TH}}{E_{MAX} - E_{TH}} \right) \quad (10)$$

If we assume a Maxwellian distribution of electron energies and if we rewrite the integral in Equation (6) in terms of the electron energy, we obtain

$$\langle R_{EXC} \rangle = \frac{2}{\sqrt{\pi}} \left( \frac{1}{kT_e} \right)^{\frac{3}{2}} \int_0^{\infty} R_{EXC} E^{\frac{1}{2}} e^{-E/kT_e} dE \quad (11)$$

For  $T_e \ll E_{TH}$ , the major contribution to the integral occurs in a limited energy range near the excitation threshold. Under these conditions, the integral may be reduced to an analytic form. This analysis, carried out in Appendix A, enables Equation (11) to be rewritten as

$$\langle R_{EXC} \rangle = 2 \sqrt{\frac{kT_e}{\pi}} E_{TH}^{\frac{1}{2}} e^{-E_{TH}/kT_e} \left. \frac{\partial R_{EXC}}{\partial E} \right|_{E=E_{TH}} \quad (12)$$

Using Equation (9), and knowing that  $v = (2E/m)^{1/2}$ ,

$$R_{EXC} = Q_{MAX} \left( \frac{E - E_{TH}}{E_{MAX} - E_{TH}} \right) \sqrt{\frac{2E}{m}}$$

$$\left. \frac{\partial R_{EXC}}{\partial E} \right|_{E=E_{TH}} = \frac{Q_{MAX}}{E_{MAX} - E_{TH}} \sqrt{\frac{2E_{TH}}{m}} = \sqrt{\frac{2}{m}} Q_{MAX} \frac{E_{TH}^{\frac{1}{2}}}{E_{MAX} - E_{TH}} \quad (13)$$

Now when Equation (13) is substituted back into Equation (12), the expression for  $\langle R_{EXC} \rangle$  becomes

$$\langle R_{EXC} \rangle = \sqrt{\frac{8kT_e}{m\pi}} e^{-E_{TH}/kT_e} Q_{MAX} \left( \frac{E_{TH}}{E_{MAX} - E_{TH}} \right) \quad (14)$$

In the analysis of Equation (11) in Appendix A, it was assumed that  $kT_e \ll E_{TH}$ . At this point, we must consider whether or not this was true for the observed gas constituents. This assumption may be verified by numerically integrating Equation (11) and comparing the results to Equation (14). Such an analysis was performed (Ref. 12) for  $T_e = 1$  eV and  $E_{TH} = 2$  eV. For these conditions, similar to cesium, the numerical integration and the analytic form agree to within 60%. If  $T_e = 1$  eV and  $E_{TH} = 10$  eV, conditions similar to argon, the agreement is better than 80%. Hence, the approximation inherent in Equation (14) is considered acceptable.

Radiative Recombination Losses. The capture of a free electron into a bound atomic state is another means of populating the upper state. This process may be represented

for atomic species B as  $B^* + e^- \rightarrow B^* + hf$ , where  $f$  is the frequency of the resultant photon. In Equation (5) the rate of this interaction is represented as  $\langle R_{REC} \rangle n_e$ . A typical interaction cross section is on the order of  $10^{-19}$  cm<sup>2</sup> (Ref. 13). Hence, for an electron with a velocity of  $10^7$  cm/sec, and for an electron number density on the order of  $10^9$ /cm<sup>3</sup>, we find that  $\langle R_{REC} \rangle n_e$  is approximately  $10^{-3}$ /sec. It will be seen in the next section that this process is negligible.

Radiative Losses. In Equation (5), it is seen that a mechanism by which an excited state is depopulated is by radiative decay to lower lying states. Consider the 8S state in cesium shown in Figure 4. Obeying the selection rules, a radiative transition from this state is allowed to the  $7P_{3/2}$ ,  $7P_{1/2}$ ,  $6P_{3/2}$ , and  $6P_{1/2}$  states. If the A coefficients are  $A_1$ ,  $A_2$ ,  $A_3$ , and  $A_4$ , respectively, then the total loss to the 8S state may be expressed as  $(A_1 + A_2 + A_3 + A_4) N_U$ . Where  $N_U$  is the population of the uppermost lying state, which in this case is 8S. This is a fairly simple expression for a state such as 8S, but the number of terms that need to be included increases as one considers states of higher  $n$  values. In general, the rate of loss to various lower states  $l$  is expressed as  $N_U \sum_l A_{UL}$ .

Tables III and IV list the radiative loss term,  $\sum_l A_{UL}$ , for each of the observed transitions in argon and cesium. The values for  $A_{UL}$  for argon were obtained from Weise, et al (Ref. 11:192), with uncertainties ranging from 25% to 50%. The listed values for  $A_{UL}$  for cesium were calculated

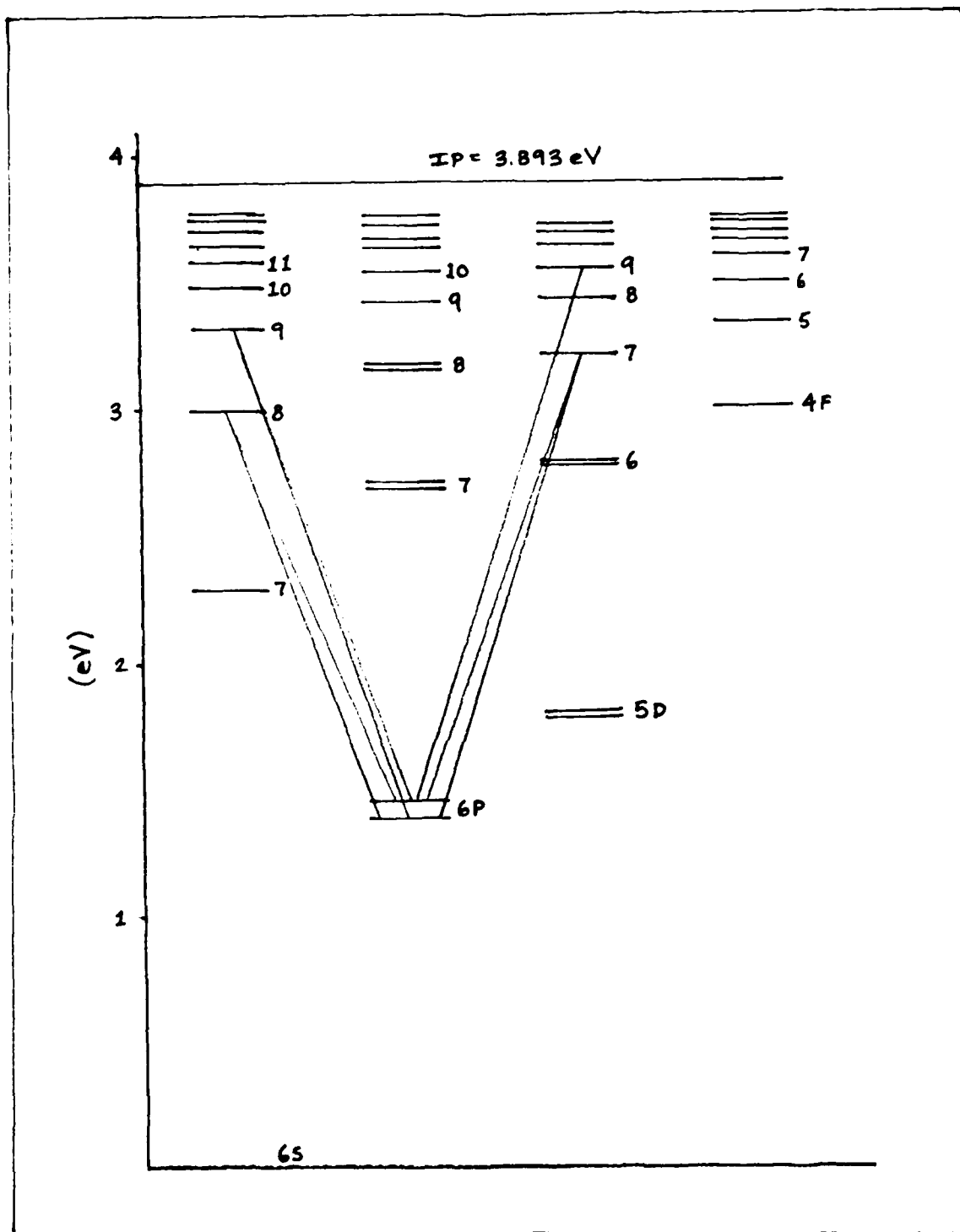

FIG. 4: Energy level diagram for Cs I. Transitions observed in this experiment have been sketched in.

from oscillator strength data collected by Fabry and Cussenot (Ref. 14:836), but no estimate of the uncertainty is given. However, Stone (Ref. 15:1151) calculated the same quantity for cesium and estimated the error to be within 50%. From Table III, the radiative losses for argon are seen to be on the order of  $10^7$ /sec. In Equation (5), this term appears in the denominator along with the radiative recombination term, which was earlier found to be on the order of  $10^{-9}$ /sec. Clearly, radiative recombination processes are negligible.

Electron Impact De-excitation Losses. Another process of depopulating an excited state is by electron impact de-excitation, denoted in Equation (5) by  $\langle R_{DEXC} \rangle_{NE}$ . A general result of detailed balance is that the cross section of de-excitation,  $Q_{DEXC}$ , may be expressed in terms of the cross section,  $Q_{EXC}$ , of the reverse process:

$$Q_{DEXC}(E) = \frac{(E + E_U - E_L) Q_{EXC}(E + E_U - E_L)}{E} \quad (15)$$

where  $E$  is the electron energy, and  $E_U$  and  $E_L$  are the levels of any two states in the atom. But for our purposes here, due to the large population of the ground state relative to any excited state, we assume that most collisions will excite from the ground state, therefore  $E_L = 0$ . Using the data in Table I and assuming a 1 eV electron, a typical value for  $Q_{DEXC}(E)$  is  $10^{-17} \text{ cm}^2$ . A similar analysis for cesium produces a value of  $10^{-15} \text{ cm}^2$ . With the electron velocity  $V$  on the order of  $5 \times 10^7 \text{ cm/sec}$

Table III

Relative Transition Probabilities and Radiative  
Loss Terms for Selected Transitions in Argon\*

<u>TRANSITION</u>	<u><math>\lambda</math> (Å)</u>	<u><math>A(10^8/\text{sec})</math></u>	<u><math>\Sigma/A(10^8/\text{sec})</math></u>
$4P_{5/2} \rightarrow 7S_{3/2}^{\circ}$	5928.8	0.011	0.052
$4P_{1/2} \rightarrow 4D_{1/2}^{\circ}$	6871.3	0.0290	0.116
$4S_{3/2}^{\circ} \rightarrow 4P'_{1/2}$	6965.4	0.067	0.857
$4S_{3/2}^{\circ} \rightarrow 4P'_{3/2}$	7067.2	0.0395	0.720
$4S_{3/2}^{\circ} \rightarrow 4P'_{3/2}$	7384.0	0.087	0.720
$4S_{3/2}^{\circ} \rightarrow 4P_{1/2}$	7514.7	0.430	0.716
$4S_{3/2}^{\circ} \rightarrow 4P_{3/2}$	7635.1	0.274	0.753
$4S_{3/2}^{\circ} \rightarrow 4P_{3/2}$	8006.2	0.0468	0.753
$4S_{3/2}^{\circ} \rightarrow 4P_{3/2}$	8103.7	0.277	0.753
$4S_{3/2}^{\circ} \rightarrow 4P_{5/2}$	8115.3	0.366	0.478

\*(Ref. 11:192)

Table IV

Relative Transition Probabilities and Radiative  
Loss Terms for Selected Transitions in Cesium\*

<u>TRANSITION</u>	<u><math>\lambda</math> (Å)</u>	<u><math>A(10^8/\text{sec})</math></u>	<u><math>\Sigma A(10^8/\text{sec})</math></u>
6P <sub>1/2</sub> ->9D <sub>3/2</sub>	5664.0	0.0226	0.0644
6P <sub>1/2</sub> ->9S <sub>1/2</sub>	6354.6	0.0103	0.0550
6P <sub>3/2</sub> ->9S <sub>1/2</sub>	6586.5	0.0181	0.0550
6P <sub>1/2</sub> ->7D <sub>3/2</sub>	6723.3	0.0711	0.1124
6P <sub>3/2</sub> ->7D <sub>5/2</sub>	6973.3	0.1957	0.2265
6P <sub>1/2</sub> ->8S <sub>1/2</sub>	7608.9	0.0214	0.0997
6P <sub>3/2</sub> ->8S <sub>1/2</sub>	7943.9	0.0385	0.0997

\* (Refs. 14:836, 15:1151)

and an electron number density  $n_e$  of  $10^{20}/\text{cm}^3$ , then the term  $\langle R_{\text{DEXC}} \rangle n_e$  is approximately  $10^{-1}/\text{sec}$  for argon and  $10/\text{sec}$  for cesium. But this competes with radiative losses, which were found earlier to be on the order of  $10^7/\text{sec}$ . Hence, electron impact de-excitation is safely ignored for both argon and cesium.

Quenching Losses. If the excited atom collides with a neutral particle, the electronic energy may be "quenched" when it is transferred into the kinetic or electronic energy of the neutral. Consider the following quenching interactions in an argon/cesium low pressure plasma:

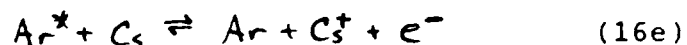
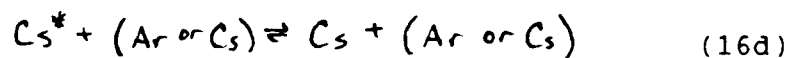
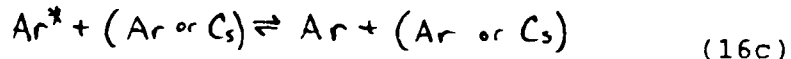
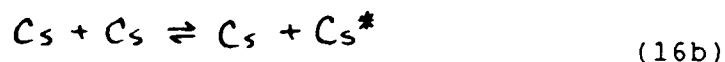

The first two processes are of little interest because they do not change the net composition of the plasma. The second two processes are true quenching interactions in which the colliding neutral particle gains kinetic energy. The last process, commonly called Penning ionization, also serves to deplete the excited state population of argon. There is not an analogous interaction which describes ionization or excitation of argon by cesium for the simple reason that

argon excited states lie at  $\sim 13$  eV, while excited cesium states do not exceed 3.9 eV.

These processes are represented in Equation (5) by  $\langle R_{\alpha} \rangle n_{\alpha}$ , or by  $\langle QV_{\alpha} \rangle$ .  $V_{\alpha}$  is the velocity of the neutral and, strictly speaking,  $Q$  should be the cross section for those atom-ion collisions which results in one of the above listed interactions. Making the hard sphere approximation, and assuming that 100% of excited atom collisions with neutrals result in quenching,  $Q$  may be estimated to be to be on the order of  $10^{-15}$  cm<sup>2</sup> and at a gas temperature of 500 K, the neutral particle velocity will be  $5 \times 10^4$  cm/sec. At operating pressures of 1.0 Torr argon and 0.04 Torr cesium, the number density of neutral argon is  $3 \times 10^{16}$ /cm<sup>3</sup>, and for neutral cesium it is  $10^{15}$ /cm<sup>3</sup>. For the processes indicated in equations (16c) and (16d),  $\langle R_{\alpha} \rangle n_{\alpha}$  is about  $10^5$ /sec, and for the Penning ionization interaction,  $\langle R_{\alpha} \rangle n_{\alpha}$  is about  $10^4$ /sec. However, both of these are small in comparison to the rate of radiative loss which is on the order of  $10^7$ /sec. Hence, quenching effects are ignored. This is a useful simplification for most transitions. However, one will note that several transitions in argon have radiative loss terms which are as low as  $10^5$ /sec. In these situations, quenching effects may play a role. But this analysis does not take this into account.

### The Resultant Expression

We have considered each term in Equation (5) and have found that electron impact excitation and radiative de-excitations are the dominant processes within a low pressure argon/cesium plasma. In comparison to these processes, radiative recombination, electron impact de-excitation and quenching losses were found to be small enough to ignore. Therefore, Equation (5) may be written as

$$I_{UL} = \frac{A_{UL} (E_U - E_L) \langle R_{EXC} \rangle n_0 n_E}{\sum_L A_{UL}} \quad (17)$$

We substitute for  $\langle R_{EXC} \rangle$  from Equation (14), and knowing that  $E_U - E_L = hc / \lambda_{UL}$ , we may re-express Equation (17) as

$$G(E) \equiv \ln \left\{ \frac{I_{UL} \lambda_{UL} \sum_L A_{UL}}{A_{UL} C} \right\} = \frac{-E_U}{kT_E} + B(n_E, T_E) \quad (18)$$

where

$$C = \frac{Q_{MAX} (E_{MAX} - E_{TH})}{E_{TH}} \quad (19)$$

and

$$B(n_E, T_E) = \ln \left\{ hc \sqrt{\frac{8kT_E}{m\pi}} n_0 n_E \right\} \quad (20)$$

At a given spatial location within the discharge  $n_E$  and  $T_E$  will be constant, thereby rendering  $B(n_E, T_E)$  constant as well. This enables Equation (18) to be viewed as a linear equation in which the slope of  $E_U$  vs.  $G(E)$  will be inversely proportional to the electron temperature. These are the equations upon which the results of this study are based.

### III. Experimental Apparatus

The apparatus described in this chapter enables spectral intensity of an argon/cesium discharge to be measured. This apparatus can be divided into several distinct subsystems: the diode, the spectroscopic, the data collection, and the vacuum and heating systems. Each of these is described below.

#### The Diode System

The Diode Structure. The heart of the experimental apparatus is the two molybdenum electrodes suspended in the center of a five-way stainless steel cross, as depicted in Figure 5. The electrodes are 2.54 cm diameter disks with a 1.8 cm gap.

Three arms of the five-way cross terminate in a conflat-type flange mounted sapphire window. Spectroscopic measurements are taken through one of these windows, visual observations are made through another, and the third window allows future experimenters to direct a laser beam into the discharge region. The electrodes are suspended through a glass-metal seal installed at the top of the fourth stainless steel arm. The fifth arm gives the discharge region access to the reservoir of cesium and to the vacuum/gas handling system. A stainless steel nipple, 7.6 cm in length and 1.9 cm outer diameter, serves as a reservoir for the cesium. The reservoir was located 14 cm from the discharge region.

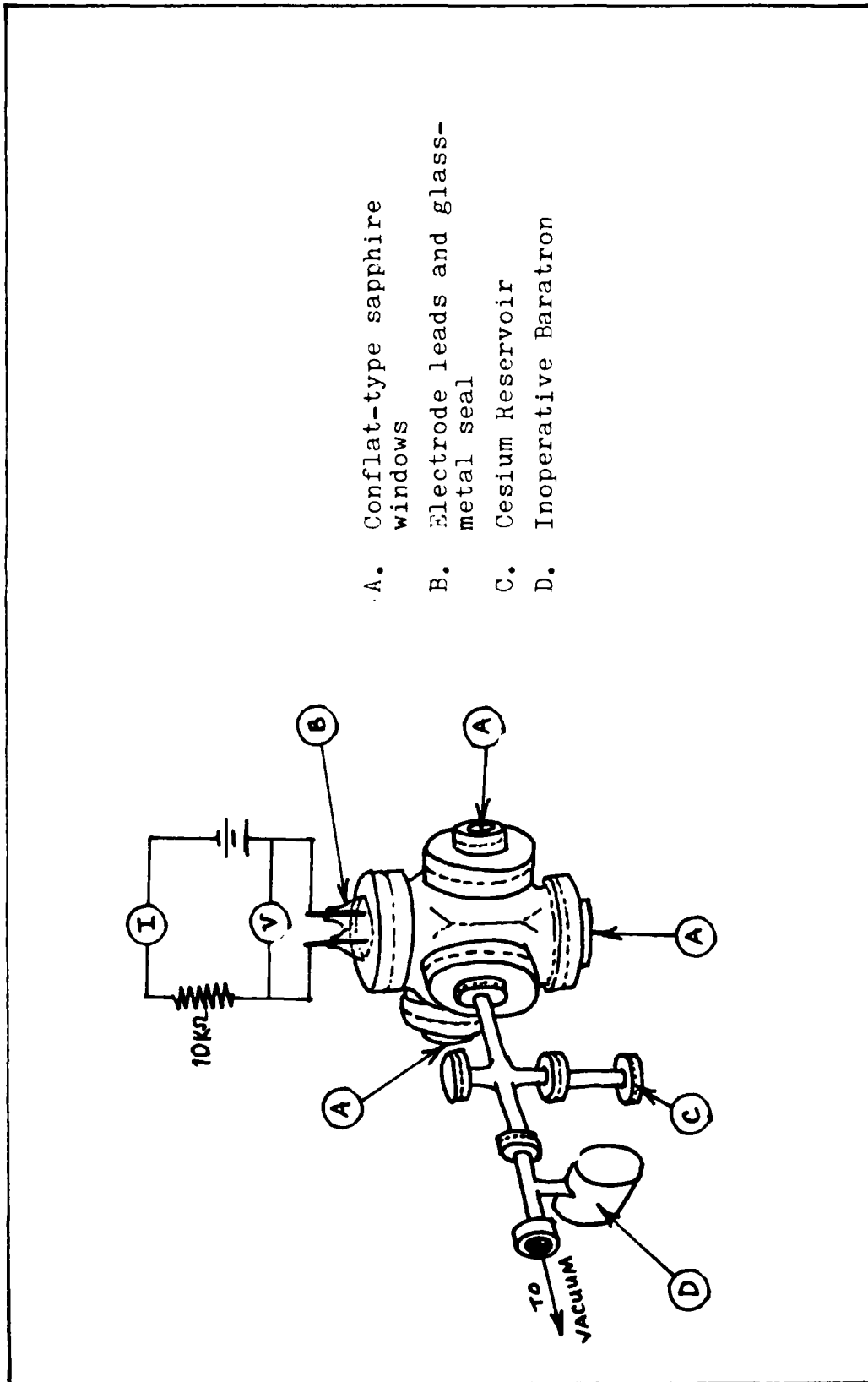

FIG. 5: Diode System

A tubular quartz shield, 6.0 cm outer diameter, is placed around the electrodes to prevent the discharge from striking between the back side of the cathode and the nearby wall of stainless steel. The shield is perforated with three 3.2 cm holes. This gives the cesium vapor freedom to diffuse into the discharge region and permits spectroscopic and visual observations to be made without having to look through what would effectively be a poor quality quartz lens.

The electrodes are connected in series with a 10 K $\Omega$  resistor, a Simpson 270 multimeter acting as an ammeter, and a Keithley constant voltage power supply. A Triplet 630-PLK multimeter, acting as a voltmeter, is installed in parallel with the electrodes.

Discharge Behavior. Visually, the discharge appeared as shown in Figure 6, where each of the labeled regions are described below. Aston's dark space, (A), was approximately 0.1 cm in width. The cathode glow, (B), was a bright lavender and was less than 0.1 cm wide. The non-equilibrium character of the discharge in these regions leads to a violation of the assumption that the plasma is in a "quasi-neutral" state. The characteristic length, L, is a measure of the distance over which quasi-neutrality is not maintained. We know that

$$L = \sqrt{\frac{kT_e}{4\pi n_e e^2}} \quad (21)$$

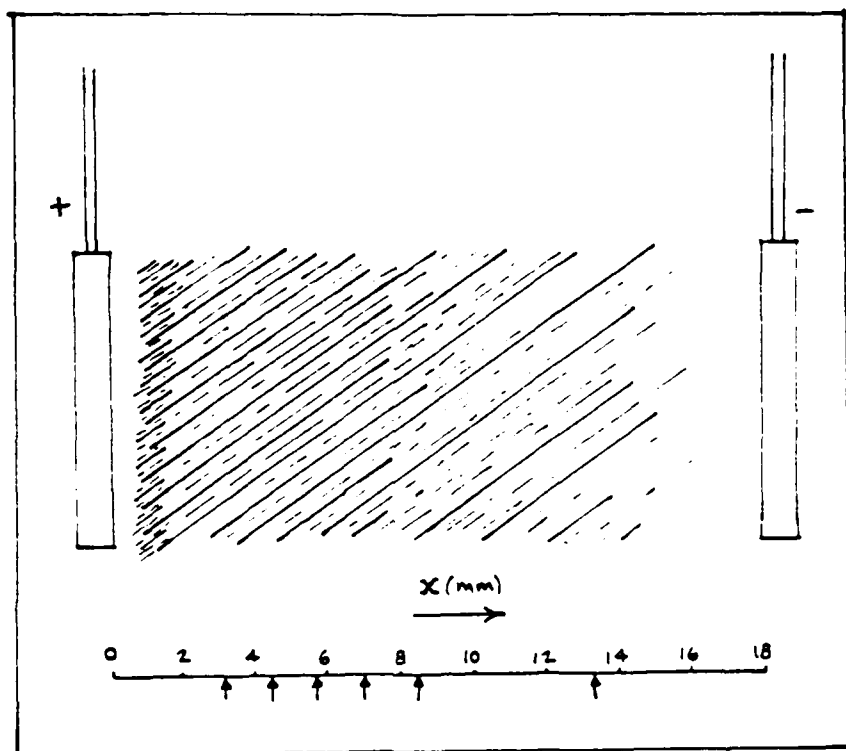

FIG. 6: Schematic diagram of visual appearance of argon/cesium discharge operating at 0.9 Torr argon, 0.04 Torr cesium, and a current density of  $1.05 \text{ mA/cm}^2$ . Arrows point to locations in discharge which were spectroscopically observed.

where  $T_E$  is in eV,  $n_E$  is in  $\text{cm}^{-3}$ , and  $L$  is in cm. For a cathode fall voltage of 170 volts and an electron number density of  $10^{19}/\text{cm}^{-3}$ , we find that  $L=0.3$  cm. This is very close to the dimensions of regions A and B in Figure 6.

The negative glow, (C), appeared to continuously merge with the cathode glow, hence the cathode dark space was not observed. The negative glow began as a bright lavender at the boundary with the cathode glow. It gradually faded to a dim purple 1.2-1.5 cm from this boundary. This dimension compares well with the expected length of 1.0 cm, as discussed in Chapter I.

#### The Spectroscopic System

The purpose of the spectroscopic system was to isolate a particular region of the plasma, image the optical radiation from that region onto a spectrometer, and convert the optical signal into an electrical signal. The arrangement of components necessary to fulfill this task is shown in Figure 7.

The radiation generated by the discharge passes through the hole in the quartz tube and then encounters the sapphire window, which has at least 80% transmission in the wavelength region 250-5500 nm. Upon leaving the diode system, the radiation passes through the first of two slits. The pair of slits, the first with a width of 0.2 cm and the second with a width of 0.5 cm, are mounted on a single micrometer-driven translatable stage, which can be moved so as to optically isolate a particular slice of the plasma.

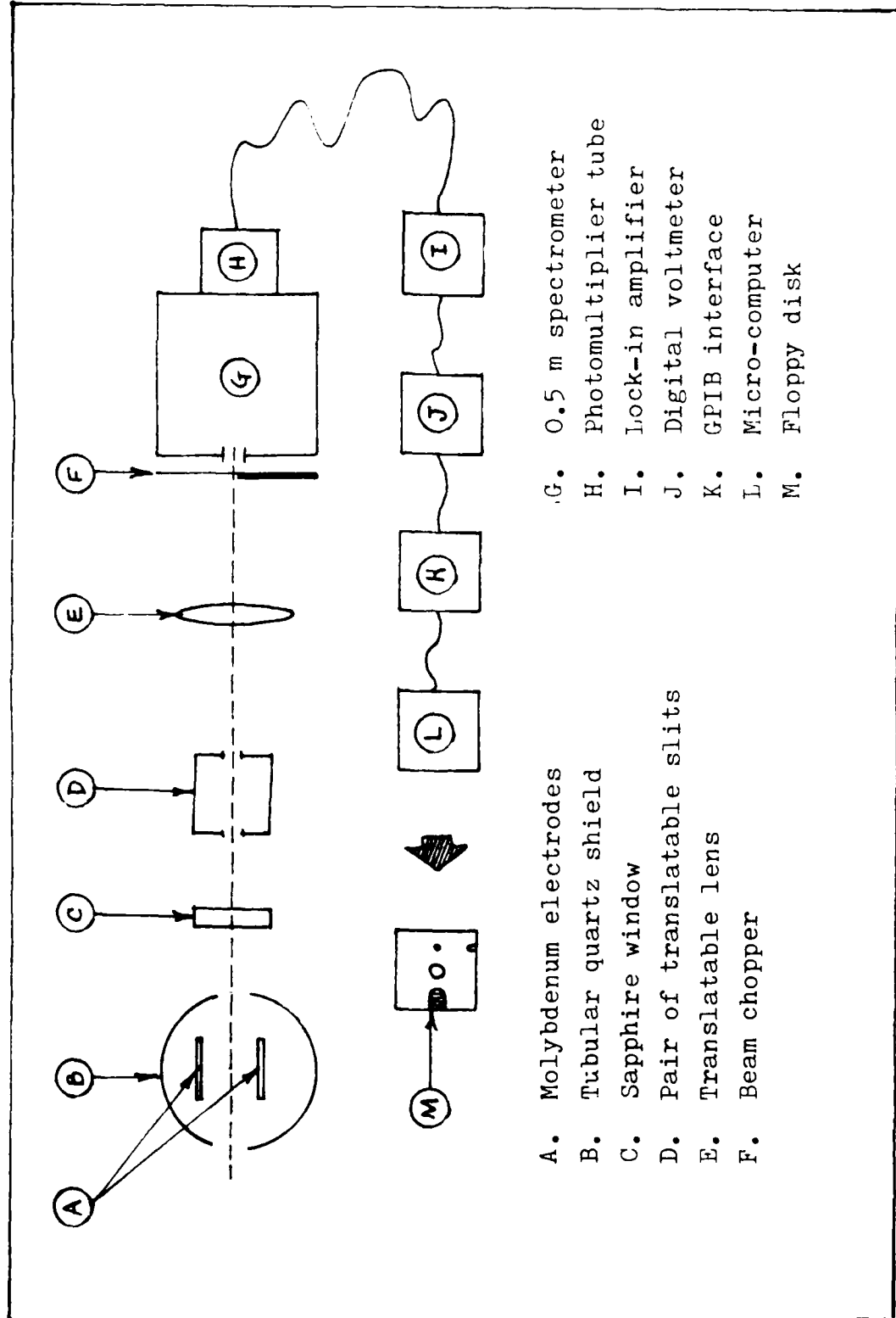

- A. Molybdenum electrodes
- B. Tubular quartz shield
- C. Sapphire window
- D. Pair of translatable slits
- E. Translatable lens
- F. Beam chopper

- G. 0.5 m spectrometer
- H. Photomultiplier tube
- I. Lock-in amplifier
- J. Digital voltmeter
- K. GPIB interface
- L. Micro-computer
- M. Floppy disk

FIG. 7: Spectroscopic System

All of the radiation which passes through the slit then falls onto a separately translatable, 10 cm focal length, 7.62 cm diameter lens. The lens is positioned to ensure that the radiation which passes through the slits is imaged onto the entrance slit of the spectrometer (0.5 mm slit widths). Knowing the widths of each slit and the magnification of the optical system, it is determined that the typical width of any observed slice of the plasma was 0.5 mm.

Before entering the spectrometer, the radiation encounters a beam chopper with a 50% duty cycle. This chopper provides a synchronizing signal to the lock-in amplifier described below. The 0.5 m Spex 1870 spectrometer, driven by a Spex CD2 CompuDrive, selects the desired wavelength and images it on the Hamamatsu R763 photomultiplier tube.

The PMT output is routed to a lock-in amplifier (10M $\Omega$  input impedance, EG&G Model 117) which converts the PMT current to a voltage signal. The output of the amplifier is detected and digitized by a Hewlett-Packard 3457A digital voltmeter. A parallel GPIB interface (Seitz 6450A) then routes the DVM signal to an HP 9836 micro-computer system, where it is recorded onto a floppy disk. Alternatively, the analog data can also be recorded onto an HP 7132A strip recorder.

Because we have chosen the spectral line intensity method of measuring the electron temperature, it is not

necessary to measure absolute intensities or to use high spectral resolution. This leads to significant experimental simplification in the sense that, although the optics are carefully aligned, high precision is not necessary.

#### The Vacuum System

The vacuum system depicted in Figure 8 consists of a small Welch roughing pump and a Varian model 0159 2-inch air cooled diffusion pump. It is capable of evacuating the diode to pressures of  $10^{-6}$  Torr. Initially, pressures were measured using a baratron attached to the diode structure. But this baratron failed at the high operating temperatures of the diode system. After this failure, an MKS model 77 differential baratron was installed as shown in Figure 8. This enables the argon pressure to be measured at room temperature prior to being introduced into the diode. An ion gauge and Granville Phillips 260 gauge controller serves to measure the pressure of the empty cell.

#### The Heating System

The stainless steel structure is heated with six 4-foot long heat tapes. The tapes are serially connected to one another in three sets of two. These three sets are also connected in parallel with one another to an HP 6443B power supply. An insulating jacket of aluminum-oxide fiber is wrapped around the entire structure. The cesium reservoir is heated with a separate heat tape, controlled by a Variac auto transformer. The reservoir is not wrapped with

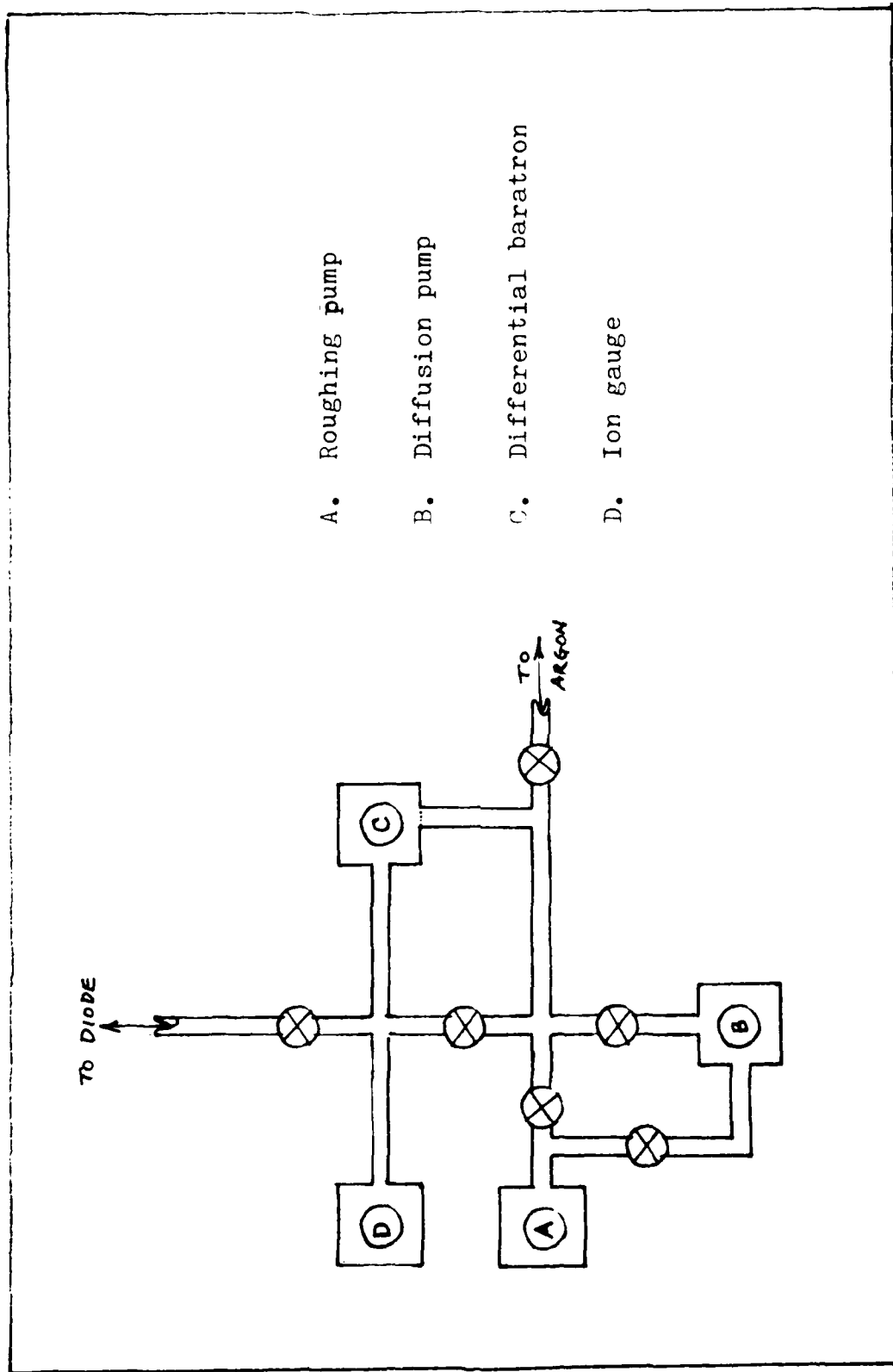

- A. Roughing pump
- B. Diffusion pump
- C. Differential baratron
- D. Ion gauge

FIG. 8: Vacuum System

aluminum oxide, which allows for rapid cooling.

Temperatures are monitored in three different locations. One K-type bead probe (Chromel-Alumel) is placed at the junction of the sapphire window and the stainless steel flange. The seal around this window has an upper temperature limit of 250°C. By monitoring the temperature at this location, we ensure that the seal does not overheat. We also ensure that this temperature remains well above that of the reservoir in order to prevent cesium from condensing onto the window.

A similar probe is located at the glass-metal seal where the electrode leads enter the cell. Due to the shape of this seal, portions of the glass are exposed to the air, despite the aluminum-oxide wrap. Hence, this is the coolest temperature of the entire cell. But since this temperature is kept well above the temperature of the reservoir, the cesium vapor in the system does not condense on this relatively cool portion of the cell.

A K-Type junction probe lies between the stainless steel exterior of the cesium reservoir and the heat tape. The temperatures measured here are assumed to be the temperature of the cesium inside the reservoir. The vapor pressure at this temperature is then obtained by means of a vapor pressure curve for cesium (Ref. 16:475). As with the other two probes, measurements are taken with a Fluke digital multimeter equipped with a linearization module.

#### IV. Experimental Procedure

Using the equipment described in the previous section, the spectral intensities of the plasma are measured with the procedure detailed below. This procedure is presented in three stages: the preliminary processes needed to "break-in" the new system, calibrating the spectroscopic system, and the spectral measurements themselves.

##### Breaking the System In

Prior to obtaining the spectral measurements, it was necessary to perform a variety of preliminary procedures. First, after wrapping the entire cell in heat tapes and aluminum-oxide blanket, it was necessary to wait for the apparatus to come to a thermal equilibrium with its surroundings. The thirty pounds of stainless steel provided enough thermal "inertia" to make the process of stabilizing at 250°C a two-day process. When a stable temperature was achieved, the cell was then left at 250°C under a vacuum of  $10^{-6}$  Torr for several more days to allow the impurities to be "baked-out" of the system.

Additionally, over a span of a few weeks, the operating voltage dropped steadily. It eventually stabilized at about 130 volts, at which point it was assumed that the system had been "broken-in" and that we could proceed with the measurements.

##### Calibration of Spectrometer

The spectrometer was calibrated using a Photon Technol-

ogies, NBS traceable calibration lamp. The spectral response of the spectroscopic system to this source was then compared to the known blackbody calibration spectrum, provided by the lamp's manufacturer, over the wavelength range of 320-820 nm. The ratio of the blackbody intensity to the measured intensity provided a calibration factor for any wavelength within this range.

The resulting calibration curve, which was normalized at 600 nm, is shown in Figure 9. The sharp peak at 680 nm is due to a sharp drop in the spectral response of the spectrometer. It was thought that this effect was an effect of the grating blazing, commonly called a Wood's anomaly. However, in discussions with the manufacturer, it was found that the grating used in this experiment is blazed for a maximum response at 700 nm.

Although this spike is not understood, it is believed to be a real effect of the spectrometer. If this were not the case, then the calibrated intensities of those spectral lines which fall between 660-710 nm would be expected to deviate substantially from those lines which are in the flatter portions of the spectral response. However, no such deviation is observed.

#### Spectral Measurements

The spectral measurements began once the above procedures had been carried out. The process of taking these measurements can be broken down into the following steps:

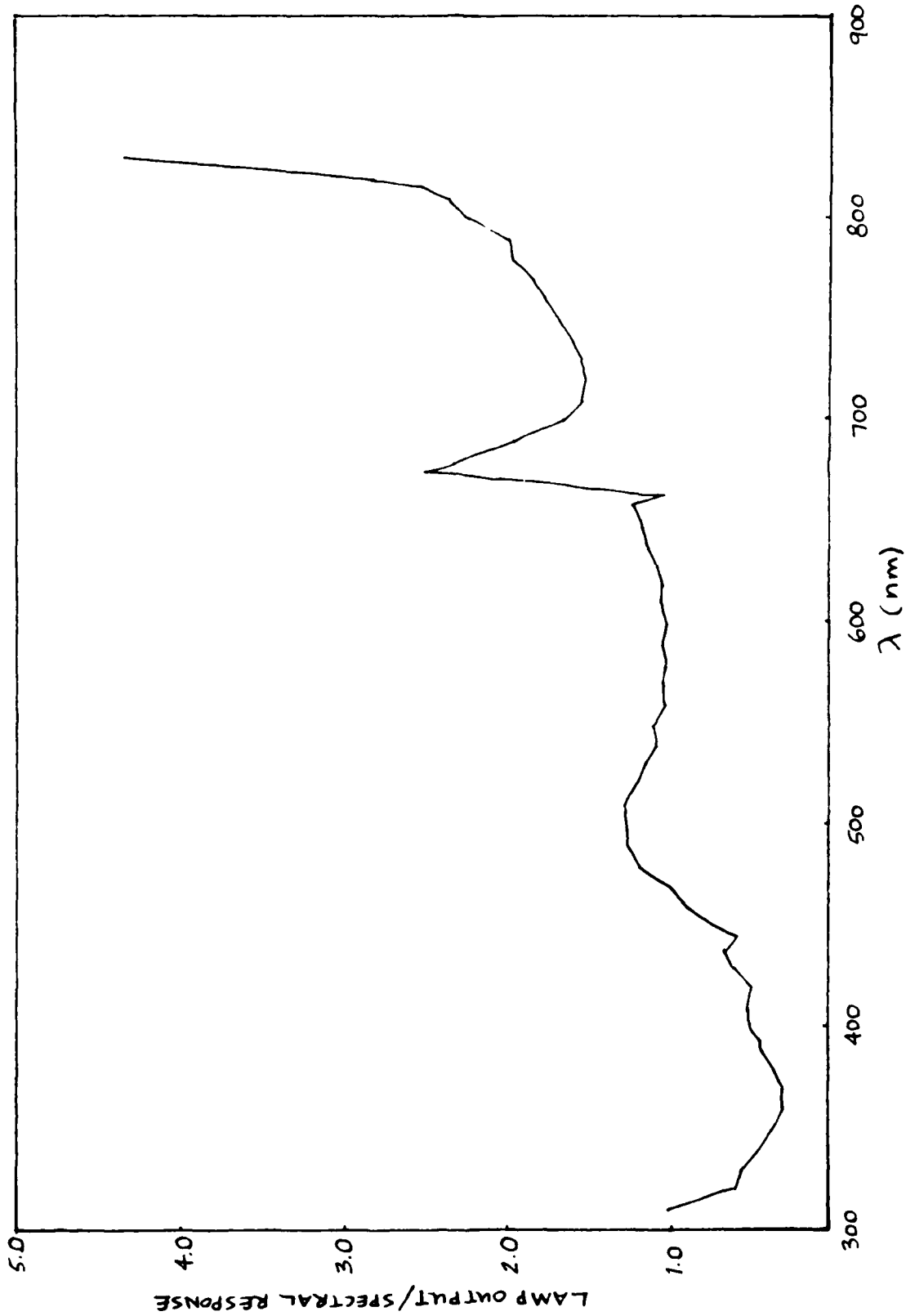

FIG. 9: Normalized calibration curve for the spectroscopic system. The vertical axis is the ratio of the blackbody intensity of the calibration lamp to the measured spectral response.

- (1) Position the double slits at the desired spatial location. This study observed the discharge at 3.18, 4.45, 5.72, 6.99, 8.26, and 13.34 mm from the cathode.
- (2) Using the spectrometer driver, slew the spectrometer to the wavelength of a bright spectral line. Observing the amplifier response, adjust the position of the lens until the response is maximized. When this occurs, it is assumed that the image of the discharge region has been centered on the spectrometer entrance slit.
- (3) Record the current, the amplifier scale, and the width of the spectrometer slits. The data presented here was taken within one twelve hour period, but during that time the current drifted in the region of 4.7-5.9 mA. Both the entrance and exit slits of the spectrometer were set at 0.5 mm.
- (4) Scan the spectrometer over the region of interest. Typically, these scans were taken over wavelength regions of 100 nm or less and were intended only to capture those spectral lines which were of particular interest. Hindsight suggests that a more thorough method would include the entire wavelength region 400-820 nm in one scan. This would facilitate both the data collection and data

analysis processes. However, in taking longer scans, one would sacrifice the ability to optimize the scanning speed and amplifier response for a small wavelength region.

- (5) Store the data on floppy disk. Using a software package originally designed by Dr. Charles deJoseph and subsequently modified by Lieutenant James Shoemaker, both of the Air Force Wright Aeronautical Laboratories, the spectrometer scans and data collection were fully automated. This same software proved useful in the data analysis described in the next chapter.

#### Determining Which Transitions to Observe

Before taking the spectral scans, it was important to ascertain which lines were of most importance. By identifying these particular lines, we could ensure that the data would be sufficient to measure the electron temperature. The selection of lines depended on the criterion described below.

- (1) The sensitivity of the photomultiplier tube limited the observations to those lines in the region of 300-820 nm.
- (2) Spatial resolution of the electron temperature demanded that the chosen lines be observable throughout the length of the discharge region.

(3) Radiative trapping eliminated some lines from being selected. The process of radiative trapping implies that every photon produced by spontaneous emission is reabsorbed before it leaves the plasma. For example, the 6S-nP series in cesium were indistinguishable from the noise even though these should have been among the strongest lines in the spectrum. This was attributed to radiative trapping.

(4) An observed line must not overlap a neighboring line to the extent that they become indistinguishable from one another.

(5) In order to obtain data over a range of energies, it was helpful to choose a complete series of transitions. In cesium, the 6P-nD and 6P-nS series were observed. Due to an oversight by this experimenter, a similar series in argon was not selected, even though an abundance of argon lines lie in the 300-500 nm range. This error resulted in a large gap in the range of energies covered by the argon spectral data.

(6) A result which is clearly evident in the cesium emission spectra is the significant enhancement of the intensity of the  $6P_{1/2} \rightarrow 10D_{3/2}$  transition ( $\lambda = 546.6$  nm). One would have expected this transition to be much less intense than the  $6P_{1/2} \rightarrow 9D_{3/2}$  ( $\lambda = 566.4$  nm) transition because of the larger value of n. But

as shown in Figure 10, such is not the case. A similar effect is also suspected for the  $6P_{1/2} \rightarrow 11S_{1/2}$  transition. Those lines which were thus enhanced were not used in the spectral analysis.

The transitions which were chosen on the basis of these criteria are listed in Tables III and IV. Hereafter, this set of transitions will be referred to as the "transitions of interest" or "spectral lines of interest."

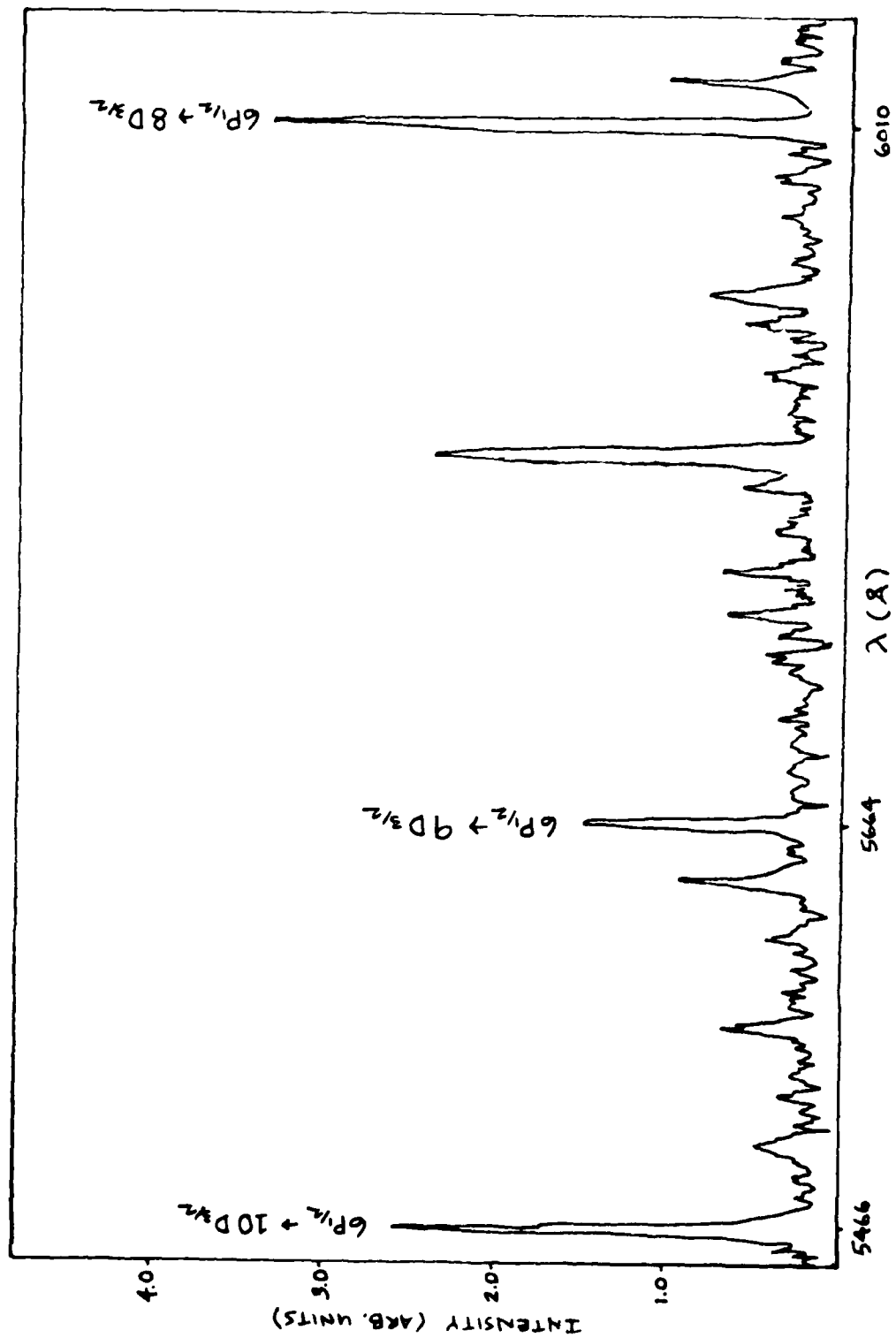

FIG. 10: Enhancement of the  $6P(1/2) \rightarrow 10D(3/2)$  transition. Due to this unexplained enhancement, this transition was not used in the spectral analysis of this study.

## VI. Data Analysis and Results

The above procedure garnered a set of several spectral scans at each of six spatial locations. At each of these locations, various portions of the emission spectrum from 545-815 nm were observed. Each of these scans included one or more spectral lines of interest in either argon or cesium. This raw data, of which an example appears in Figure 11, was reduced in order to yield a relative spectral intensity. Then using the equations derived in chapter II, these intensities were used to calculate the electron temperature of the plasma. This chapter explains each of these steps in the process of transforming the raw data into a measurement of electron temperature.

### Calculating the Intensity

Taking a closer look at the data in Figure 11, we select one of the lines of interest and reproduce it in more detail in Figure 12. In order to calculate the full intensity of this line, we follow this procedure:

- (1) Estimate the average level of the background,  $H_B$ .
- (2) Measure the height of the peak,  $H_P$ , and define the total height,  $H_T$ , as  $H_T = H_B + H_P$ .
- (3) If  $H_{1/2}$  is the half-maximum height of the peak as measured from the background level, then

$$H_{1/2} = (H_T - H_B) / 2$$

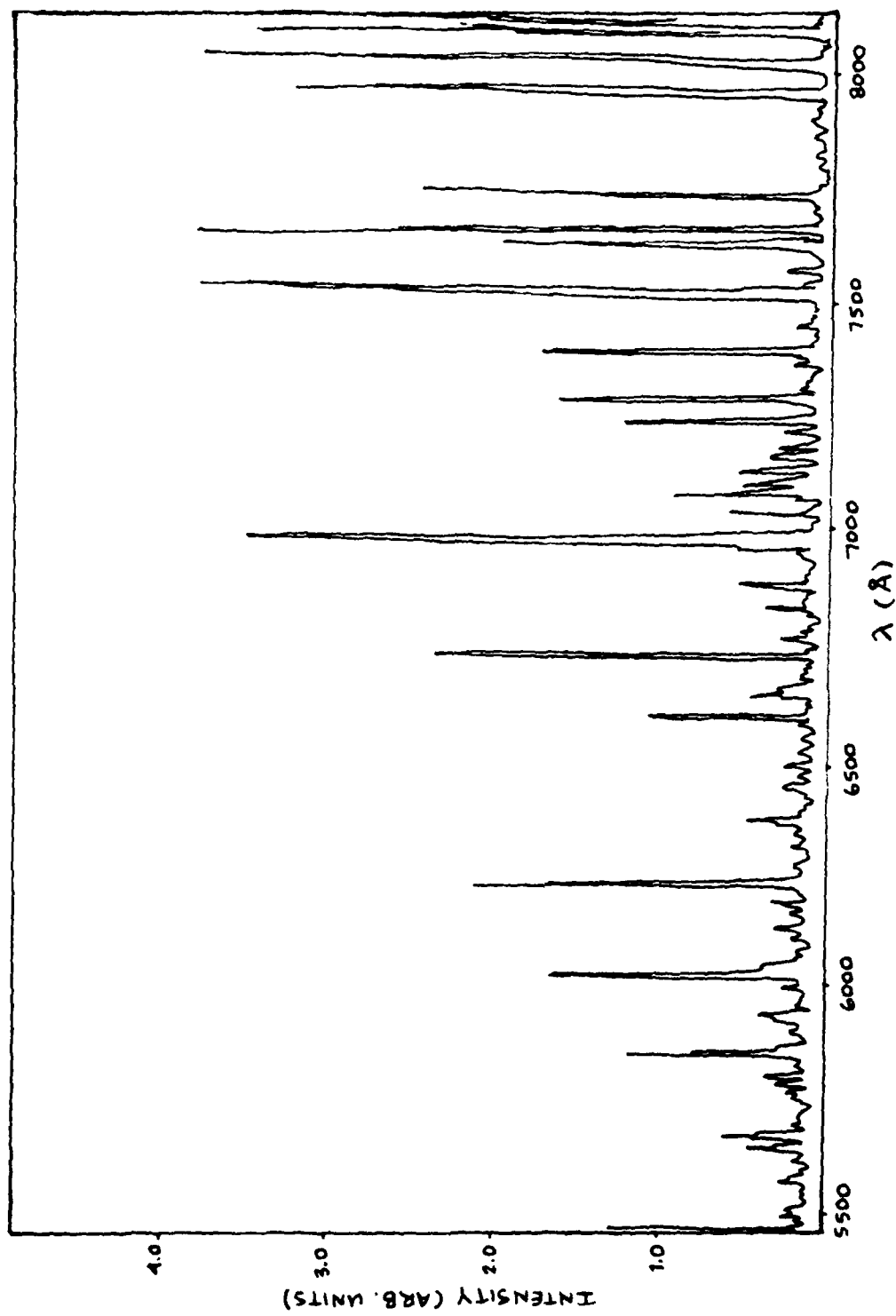

FIG. 11: Sample spectral scan of 5450-8150 Å.

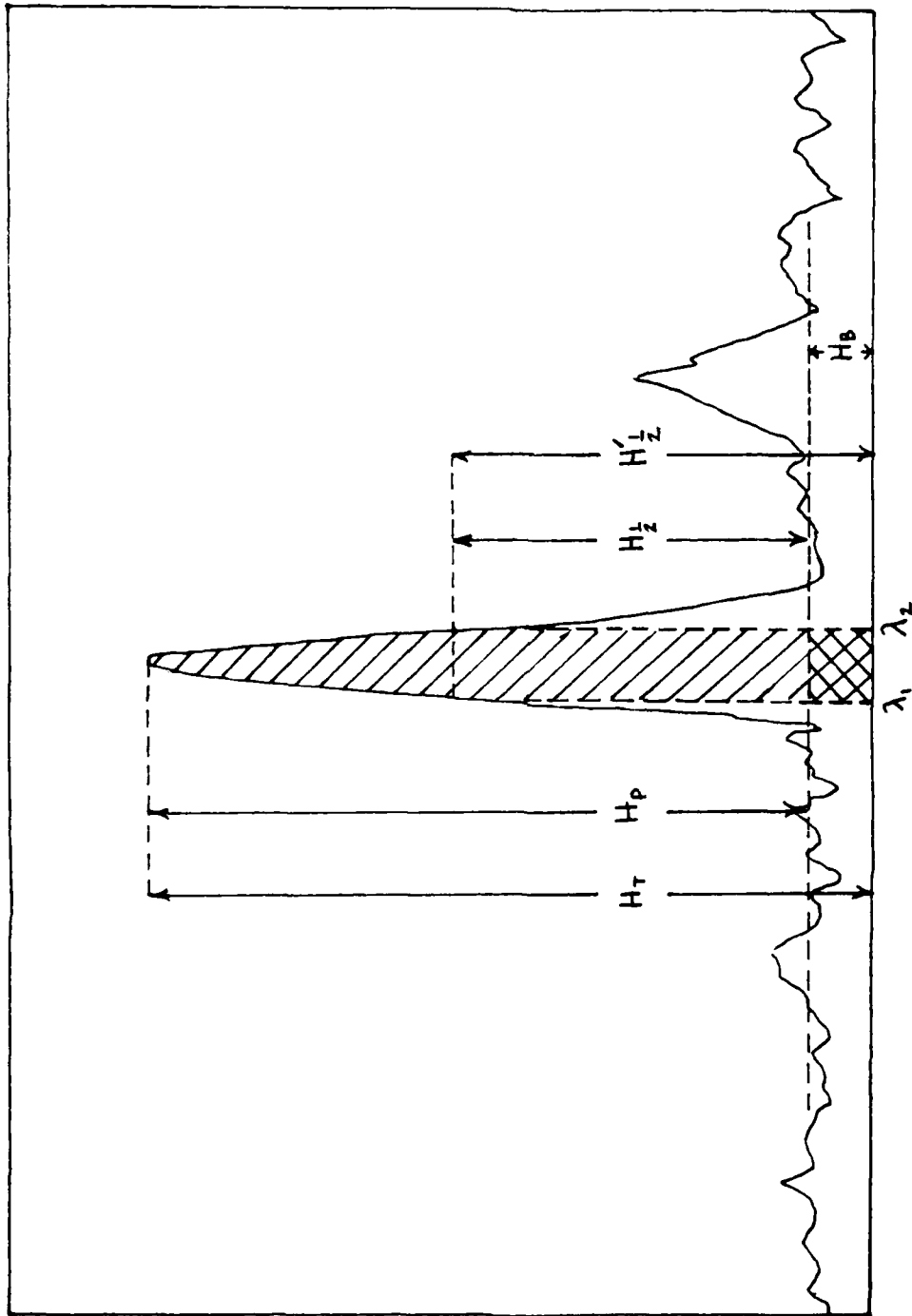

FIG. 12: Detail of how spectral intensities were measured

But the software gave intensity values as measured from the zero intensity level, without subtracting the background. Hence, we define  $H'_{1/2}$  to be the half-maximum height as measured from the zero intensity level, where  $H'_{1/2} = H_{1/2} + H_B$ . Therefore

$$H'_{1/2} = \frac{H_T + H_B}{2}$$

(4) By marking the locations of the half-maximum intensity, the corresponding values of  $\lambda_1$  and  $\lambda_2$  are obtained, where  $FWHM = \lambda_2 - \lambda_1$ .

(5) The software which is responsible for collecting the data also integrates the area under the entire spectral output. This yields a value for the integrated area,  $A(\lambda)$ , at any point in the spectrum. Hence,  $A(\lambda_2) - A(\lambda_1)$  is the area of the shaded portion of the line profile in Figure 12.

(6) The background area, which has been cross-hatched in Figure 12, is subtracted from the quantity  $A(\lambda_2) - A(\lambda_1)$  in order to find the total area,  $A_T(\lambda)$ :

$$A_T(\lambda) = (A(\lambda_2) - A(\lambda_1)) - H_B(\lambda_2 - \lambda_1)$$

(7) Before obtaining a final value for the integrated intensity, two more terms need to be evaluated. The calibration factor,  $C(\lambda)$ , is assumed to be constant in the wavelength region between  $\lambda_1$  and  $\lambda_2$ . A value for  $C(\lambda)$  is taken from Figure 9. The multiplier on the

lock-in amplifier also needs to be taken into account. Denote this factor by  $W$ . Therefore, the integrated intensity  $I$  is given by

$$I = \left( (A(\lambda_2) - A(\lambda_1)) - H_B(\lambda_2 - \lambda_1) \right) C(\lambda) W \quad (22)$$

### Calculations

Following the procedure outlined above, the integrated intensity values,  $I$ , are calculated from the raw spectral data. But this information needs to be processed through Equation (18),

$$G(E) = \ln \left\{ \frac{I_{UL} \lambda_{UL} \sum A_{UL}}{A_{UL} C} \right\} = \frac{-E_U}{kT_E} + B(\eta_E, T_E) \quad (18)$$

before the electron temperature can be determined. The values for  $A_{UL}$  and  $\sum A_{UL}$  are taken from Tables III and IV. The quantity  $C$  is defined in Equation (19) and is calculated from the data listed in Tables I and II. Knowing the characteristic wavelength,  $\lambda_{UL}$ , of the transition,  $G(E)$  is calculated for the spectral lines of interest in both argon and cesium at six spatial locations within the discharge.

The results are presented in Appendix B in the plots of  $G(E)$  vs  $E$  for both argon and cesium spectral emission data at each spatial location. Using a least squares fitting program, a linear fit is then applied to the data. This produces a value for the slope and standard deviation of the slope, where the slope is inversely proportional to electron temperature.

One will note that no line has been plotted for the

argon emission data at 13.34 mm from the cathode. At this distance into the negative glow, argon emission intensities had dropped significantly. Therefore, at this spatial location the sample of lines was deemed as insufficient to determine a line. The data is only presented for the sake of completeness.

A prominent feature of these results is the large uncertainty in the calculated slope of  $G(E)$  vs.  $E$ , and hence in the uncertainty of the value for  $T_e$ . The uncertainty calculations reveal that the experimental uncertainty of 12% is dwarfed by the uncertainties in the literature values for oscillator strengths and transition probabilities, which vary from 25% to 60%. These large uncertainties in literature values are the limiting factor in assessing the reliability of the measurements.

Another outstanding feature is that two electron temperatures are measured by observing the emission spectra of the two different gas species. The argon data measures an average electron temperature of 13,500 K throughout the entire discharge region, while the average temperature measured by the cesium data is 8200 K. This result is discussed in the following chapter.

## VII. Conclusions and Recommendations

The purpose of this study was to apply spectral intensity measurements as a means to measure the electron temperature in a low pressure argon/cesium plasma. The device was operated at 0.9 Torr argon, 0.04 Torr cesium, and at a current density of  $1.05\text{mA/cm}^2$ . The electron temperature was determined spectroscopically using the line intensity technique outlined in Chapter II. This method was applied to the 6P-nS and 6P-nD series in cesium and to a set of transitions in argon. The cesium emission data characterize the low-energy electrons as an 8200 K Maxwellian, whereas the argon emission data a temperature of 13500 K. Within the uncertainties of the results, it is not possible to discern any spatial variation in these temperatures.

If the distribution of electron energies was purely Maxwellian, as assumed in the theoretical discussion of Chapter II, then one would have expected both argon and cesium data to reveal a single electron temperature. The fact that this study yields two distinct temperatures based on a measurement of the emission by the argon/cesium plasma confirms that under the given highly non-equilibrium plasma conditions, the electron energy distribution is non-Maxwellian.

Referring to the electron energy distributions sketched in Figure 2, we expected the negative glow to contain two groups of electrons. The "fast" group, which retain much of the energy from the cathode fall, are characterized by a large electron temperature. The "slow" group, which grow in

number as the beam-like particles become thermalized, would correspond to a smaller temperature. In this study, argon is found to be sensitive to the fast electrons, while cesium is more affected by the slower electrons.

To facilitate future study, the following recommendations concerning the apparatus are proposed:

(1) One limiting factor on the diode operation was a tendency for the discharge to jump to the inside walls of the stainless steel system, particularly to the welded joints. This could be offset by moving the electrodes closer together or by using a larger stainless steel structure. Using glass instead of steel would eliminate this problem altogether.

(2) In order to prevent the cathode from sputtering cesium onto the sapphire windows, the current was kept below 10 mA. A glass shroud placed around the cathode would reduce the sputtering problem and would also discourage the discharge from jumping to the stainless steel wall behind the cathode. However, installing such a shroud might necessitate bringing the electrodes in from the side of the cell rather than from the top.

(3) The considerable thermal "inertia" of the stainless steel cell led to a wait of several days as the system was brought to a stable temperature of 250°C. From this standpoint, a quickly heating glass system,

would be preferable. However, glass does not distribute heat as evenly as the stainless steel.

(4) The time spent in changing the cesium pressure could be reduced if the cesium reservoir were moved closer to the electrode gap. At the reservoir location depicted in Figure 5, it is a several hour process for the cesium to distribute itself evenly throughout the cell volume.

The following recommendations concern the experimental and analytical approach:

(1) The argon spectral emission data can be made more complete if the 300-500 nm range is scanned.

(2) The accuracy of this method can not be improved until literature values with smaller uncertainties can be found for transition probabilities, absorption oscillator strengths, and excitation cross sections for both argon and cesium.

(3) The calibration of the spectrometer was not done in absolute units. Hence, measured intensities are only useful when they are compared to one another. It is suggested that, in future studies, an absolute calibration be made. This would be useful in determining the number densities of the gas species (Ref. 17:997).

Appendix A: Estimating the Integral in the Calculation of the Average Rate of Electron Impact Excitation

We begin with the following integral:

$$\Pi = \int_0^{\infty} R_{\text{EXC}} E^{\frac{1}{2}} e^{-E/kT_E} dE$$

As noted in the text, the overlap between  $E^{1/2} \exp(-E/kT_E)$  and  $R_{\text{EXC}}$  is small. Since  $R_{\text{EXC}}$  and  $E^{1/2}$  are slowly varying functions in this region, they may be approximated by linear functions whose slopes are given by the slopes of the original functions at  $E=E_{\text{TH}}$ . This suggests redefining the coordinate origin to  $E=E_{\text{TH}}$ , and defining a new coordinate  $E^*$ , where  $E^*=(E-E_{\text{TH}})/kT_E$ . Hence, the linear approximations to  $R_{\text{EXC}}$  and  $E^{1/2}$  may be written as

$$H_1(E^*) = (kT_E E^* + E_{\text{TH}})^{\frac{1}{2}} \approx M_1 E^* + B_1$$

$$H_2(E^*) = R_{\text{EXC}} \approx M_2 E^* + B_2$$

where  $M_1$ ,  $M_2$  are the slopes and  $B_1$ ,  $B_2$  are the ordinate intercepts. These are given by

$$M_1 = \left. \frac{\partial H_1}{\partial E^*} \right|_{E^*=0} = \left. \frac{kT_E}{2} (kT_E E^* + E_{\text{TH}})^{-\frac{1}{2}} \right|_{E^*=0} = \frac{kT_E}{2\sqrt{E_{\text{TH}}}}$$

$$M_2 = \left. \frac{\partial H_2}{\partial E^*} \right|_{E^*=0} = \left. \frac{\partial R_{\text{EXC}}}{\partial E^*} \right|_{E^*=0} = kT_E \left. \frac{\partial R_{\text{EXC}}}{\partial E} \right|_{E=E_{\text{TH}}}$$

$$B_1 = H_1 \Big|_{E^*=0} = \sqrt{E_{\text{TH}}}$$

$$B_2 = H_2 \Big|_{E^*=0} = R_{\text{EXC}} \Big|_{E=E_{\text{TH}}} = 0$$

Pulling this together, we have the following linear approximations

$$H_1(E^*) = \frac{kT_E}{2\sqrt{E_{TH}}} + E_{TH}^{\frac{1}{2}} = E_{TH}^{\frac{1}{2}} \left( \frac{kT_E E^*}{2E_{TH}} + 1 \right)$$

$$H_2(E^*) = \left( \frac{\partial R_{exc}}{\partial E} \right) \Big|_{E=E_{TH}} E^* kT_E$$

So the integral may be rewritten as

$$\begin{aligned} \text{II} &= \int_0^{\infty} H_1(E^*) H_2(E^*) e^{-(kT_E E^* + E_{TH})/kT_E} kT_E dE^* \\ &= E_{TH}^{\frac{1}{2}} \frac{\partial R_{exc}}{\partial E} \Big|_{E=E_{TH}} e^{-E_{TH}/kT_E} (kT_E)^2 \int_0^{\infty} E^* \left( \frac{kT_E E^*}{2E_{TH}} + 1 \right) e^{-E^*} dE^* \end{aligned}$$

Going only to first order in  $kT_E/E_{TH}$ , since  $kT_E \ll E_{TH}$ , the integral becomes

$$\text{II} = E_{TH}^{\frac{1}{2}} e^{-E_{TH}/kT_E} \frac{\partial R_{exc}}{\partial E} \Big|_{E=E_{TH}} (kT_E)^2$$

Appendix B: Plots of G(E) vs E for Argon and Cesium  
Spectral Emission Data at Various Spatial Locations

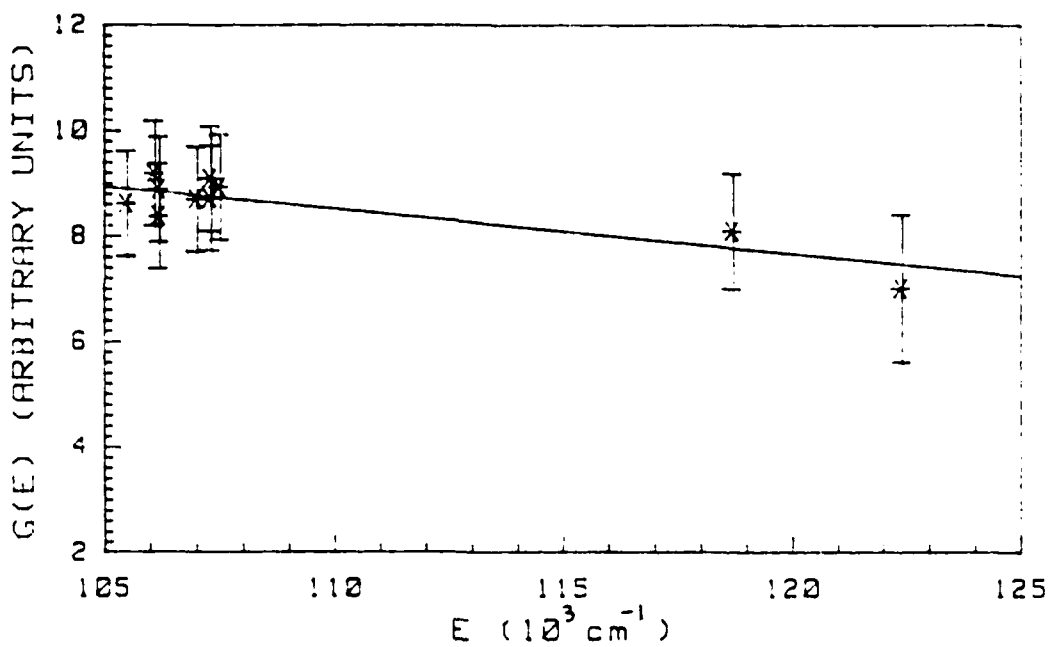

FIG.13 :Ar TRANSITIONS AT 3.18 mm FROM CATHODE

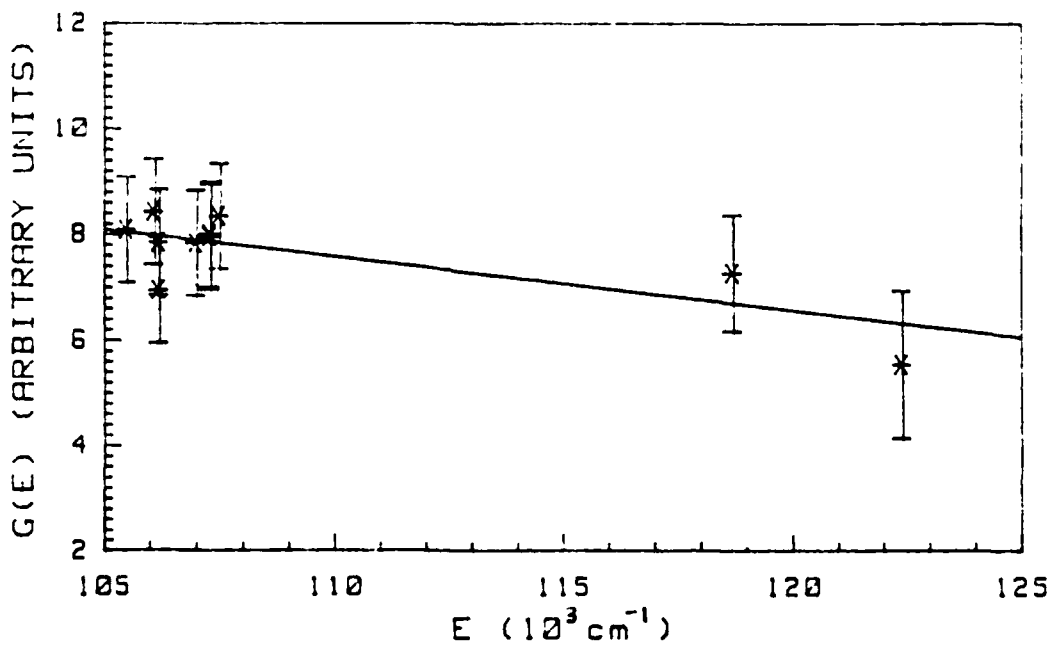

FIG.14 :Ar TRANSITIONS AT 4.45 mm FROM CATHODE

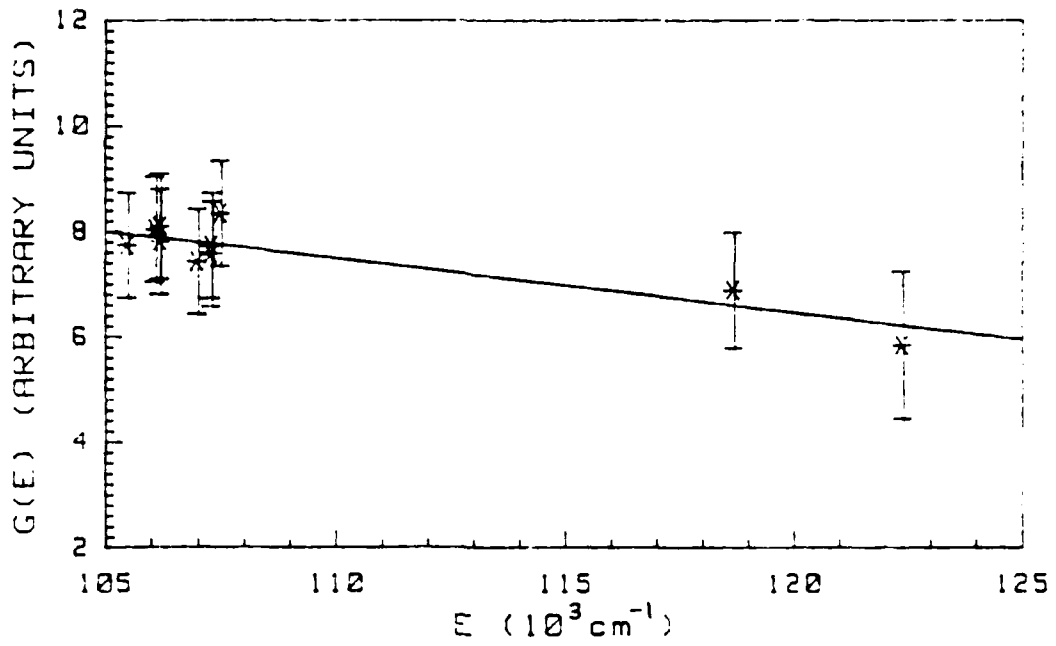

FIG. 15: Ar TRANSITIONS AT 5.72 mm FROM CATHODE

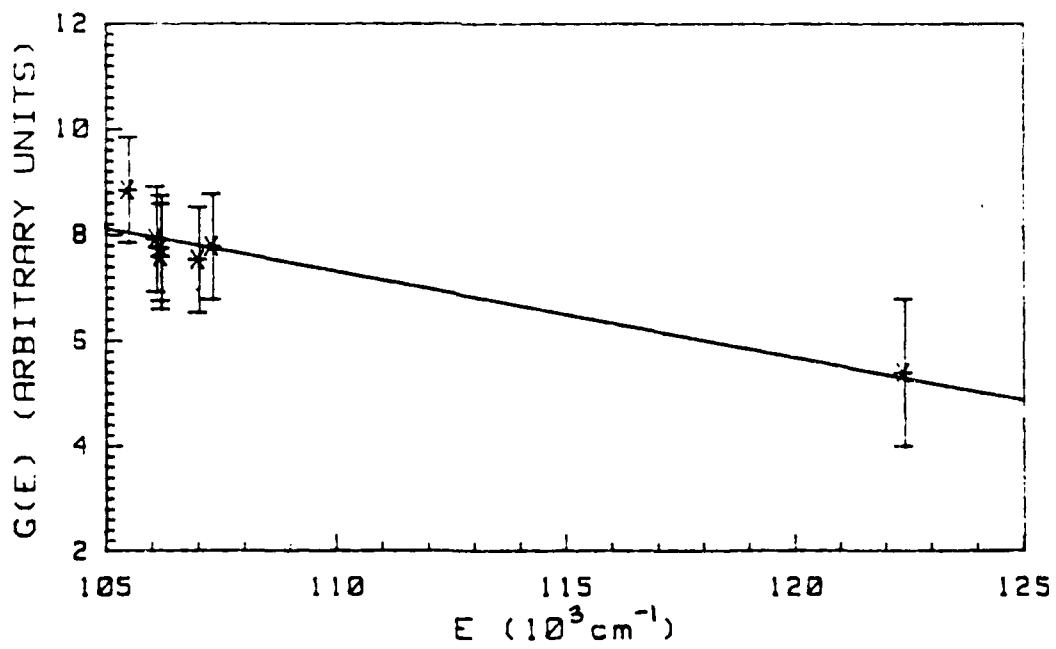

FIG. 16: Ar TRANSITIONS AT 6.99 mm FROM CATHODE

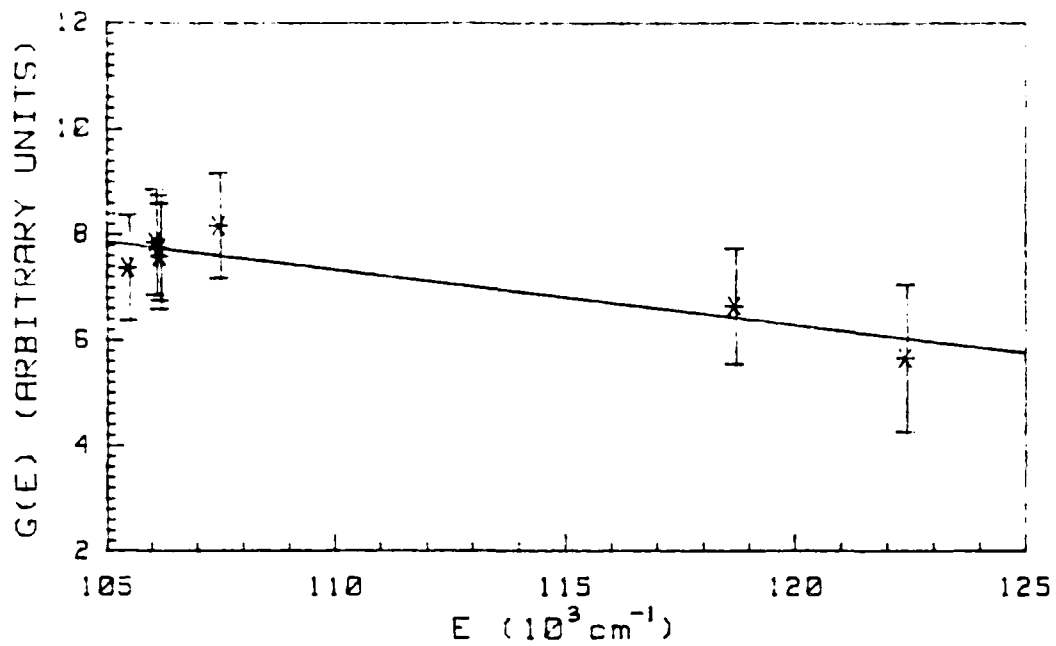

FIG. 17: Ar TRANSITIONS AT 8.25 mm FROM CATHODE

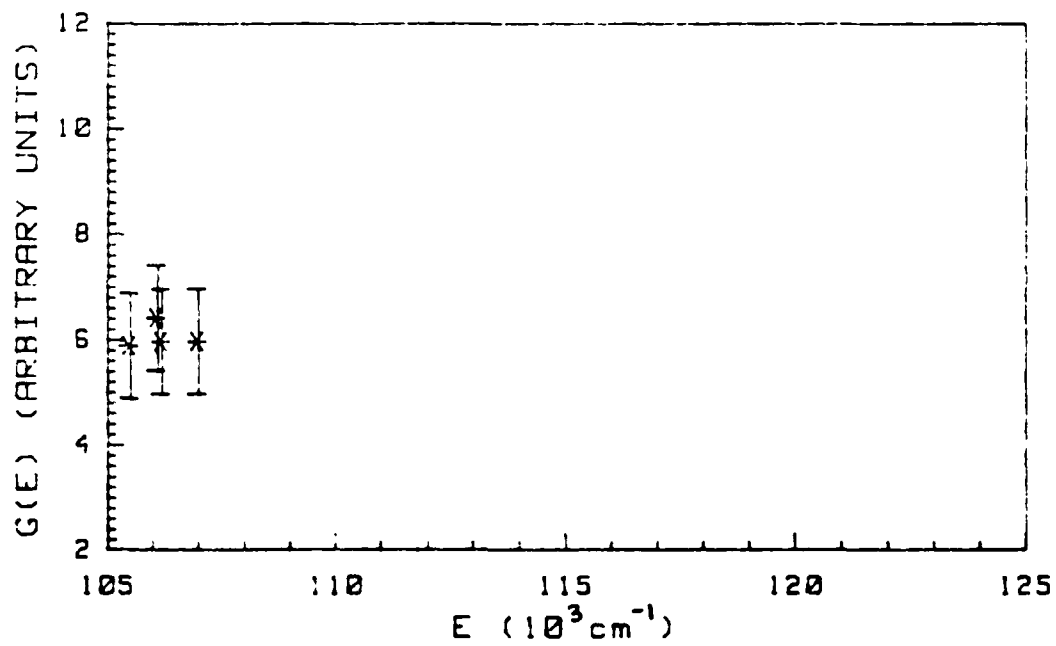

FIG. 18: Ar TRANSITIONS AT 13.34 mm FROM CATHODE

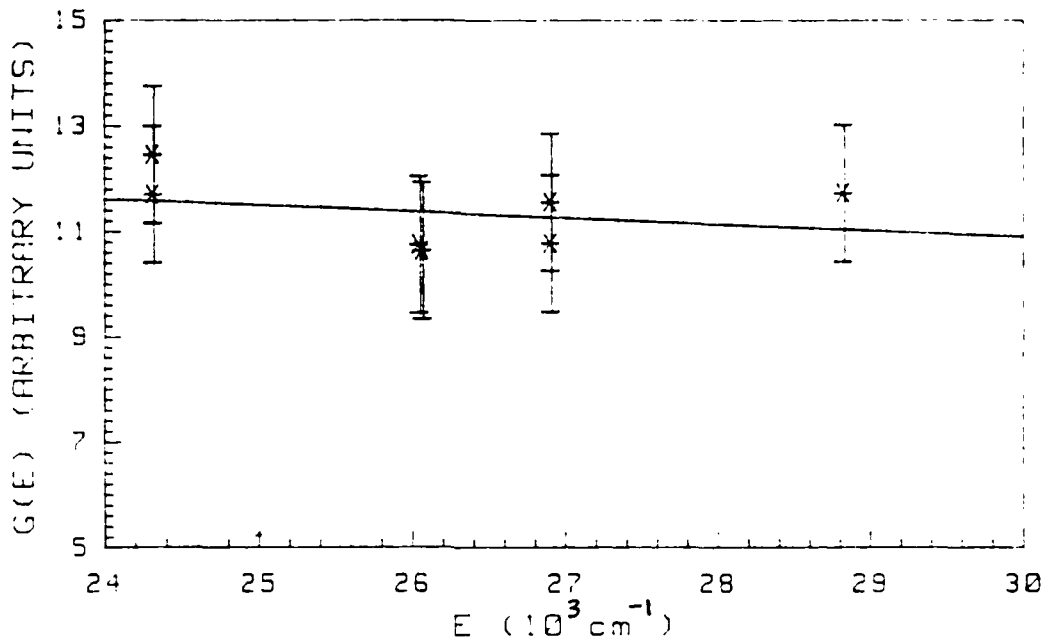

FIG. 19: Cs TRANSITIONS AT 3.18 mm FROM CATHODE

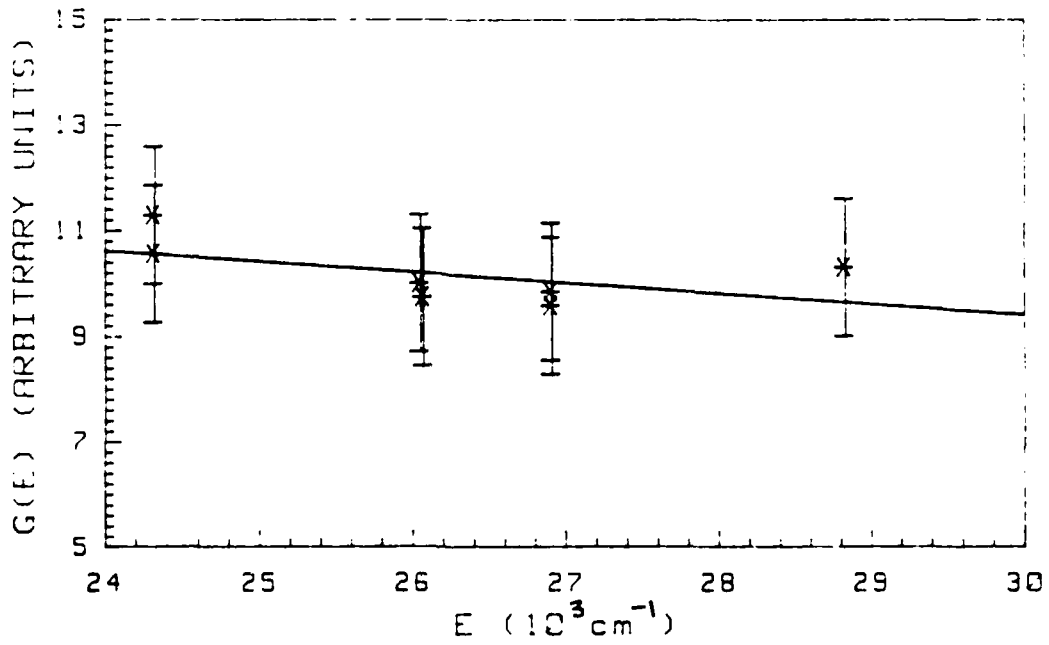

FIG. 20: Cs TRANSITIONS AT 4.45 mm FROM CATHODE

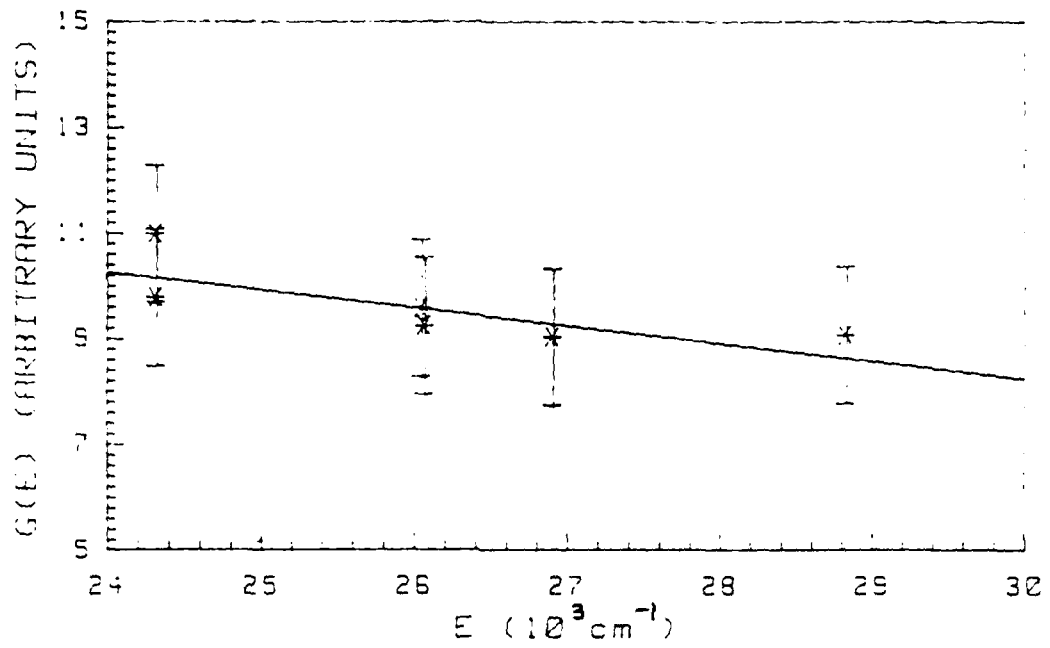

FIG. 21: Cs TRANSITIONS AT 5.72 mm FROM CATHODE

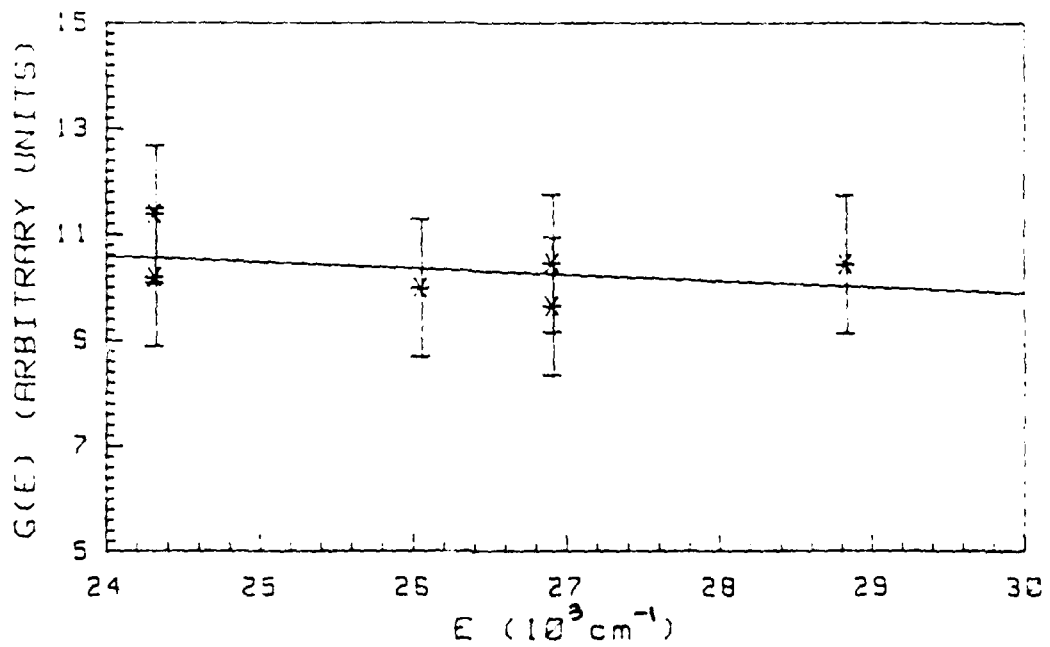

FIG. 22: Cs TRANSITIONS AT 6.99 mm FROM CATHODE

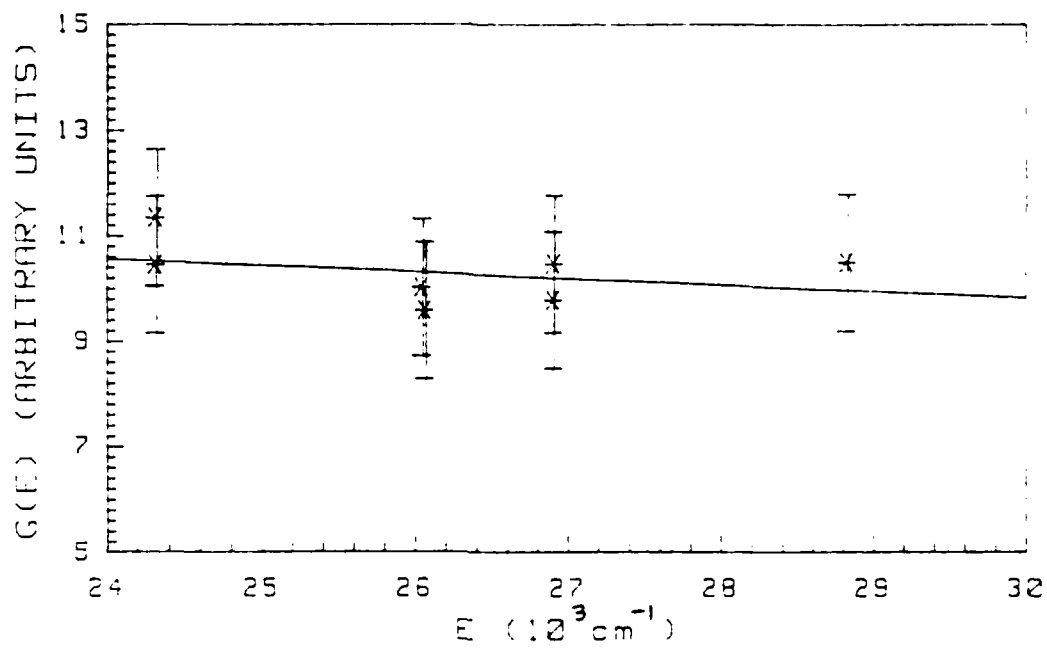

FIG.23 : Cs TRANSITIONS AT 8.26 mm FROM CATHODE

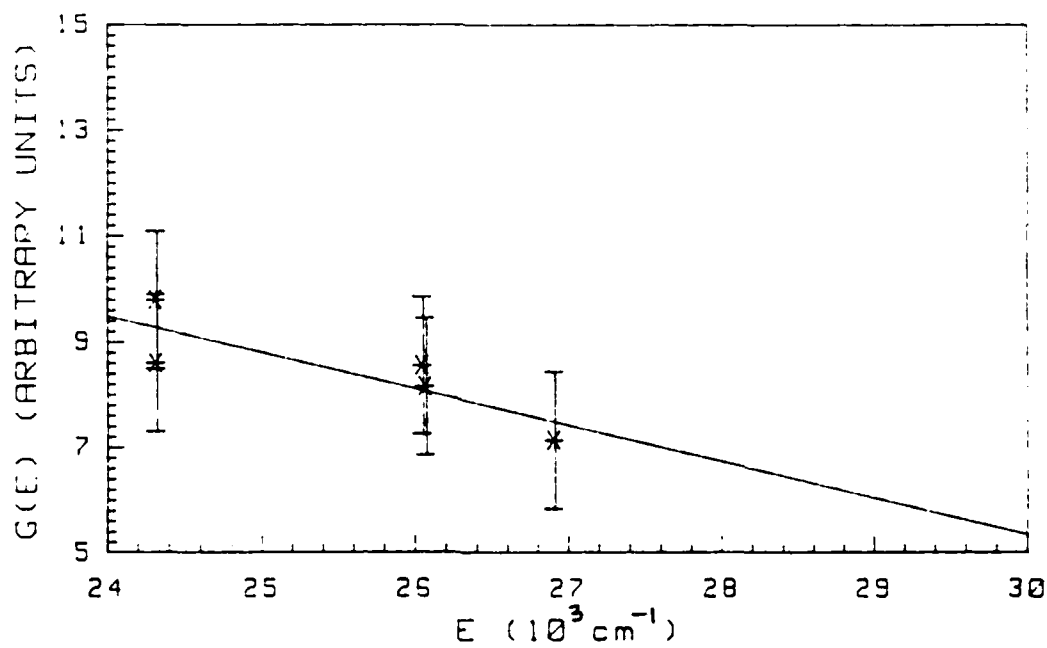

FIG.24 : Cs TRANSITIONS AT 13.34 mm FROM CATHODE

## Bibliography

1. von Engel, A. Ionized Gases, Oxford University Press, London, 217, (1965).
2. van Gorcum, A.H. Physica, Haag, 3:207 (1936).
3. Brewer, A.K. and J.W. Westhaver. Jour. App. Phys., 8:779 (1937).
4. Zapesochnyi, I.P., P.V. Feltsan. Opt. Spect., 20:291 (1966).
5. Zapesochnyi, I.P., L.L. Shimon. Opt. Spect., 20:421 (1965).
6. Zapesochnyi, I.P. High Temp., 5:6 (1967).
7. Zapesochnyi, I.P., L.L. Shimon. Opt. Spect., 16:504 (1964).
8. Drawin, H.W. "Atomic Cross-Sections for Inelastic Electronic Collisions," Report EUR-CEA-FC236, (1963).
9. Mitchner, M., C.H. Kruger. Partially Ionized Gases, John Wiley and Sons, New York, 27, (1973).
10. Petersen, L.R., J.E. Allen Jr. Jour. Chem. Phys., 56:6068 (1972).
11. Wiese, W.L., et al. Transition Probabilities, vol. 2. National Standard Reference Data System-National Bureau of Standards 22, 192, (1968).
12. Bailey, W.F. Air Force Institute of Technology. Private discussions. Air Force Institute of Technology, Wright-Patterson A.F.B., OH, Oct-Nov 1987.
13. Bioni, M.A. "Recombination," Principles of Laser Plasmas, ed. G. Bekefi, John Wiley and Sons, New York, (1976).
14. Fabry, M., J.R. Cussenot. Can. Jour. Phys., 54:836 (1976).
15. Stone, P.M. Phys. Rev., 127:1151 (1962).
16. Honig, R.E. "Vapor Pressure Data for the Elements," The Characterization of High-Temperature Vapors, ed. J.L. Margrave, John Wiley and Sons, New York 475 (1967).
17. Robinson, D.R., P.D. Lenn. App. Opt., 6:983 (1967).

## VITA

Lieutenant Michael J. Ward was born on 29 July 1964 in Hollywood, California. He graduated from high school in Newbury Park, California in 1982 and attended Harvey Mudd College in Claremont, California until May 1986, at which time he received the degree of Bachelor of Science in Physics. Upon graduation, he received a commission in the USAF through ROTC Detachment 060. He entered the School of Engineering, Air Force Institute of Technology, in June 1986.

Permanent Address: 4411 Burkhardt Ave., Apt. A7  
Dayton, OH 45431

REPORT DOCUMENTATION PAGE

Form Approved  
 OMB No. 0704-0188

1a. REPORT SECURITY CLASSIFICATION UNCLASSIFIED		1b. RESTRICTIVE MARKINGS	
2a. SECURITY CLASSIFICATION AUTHORITY		3. DISTRIBUTION/AVAILABILITY OF REPORT Approved for public release; distribution unlimited.	
2b. DECLASSIFICATION/DOWNGRADING SCHEDULE		4. PERFORMING ORGANIZATION REPORT NUMBER(S) AFIT/GE/GEF/87D-9	
4. PERFORMING ORGANIZATION REPORT NUMBER(S) AFIT/GE/GEF/87D-9		5. MONITORING ORGANIZATION REPORT NUMBER(S)	
6a. NAME OF PERFORMING ORGANIZATION School of Eng.	6b. OFFICE SYMBOL (If applicable) AFIT/ENG	7a. NAME OF MONITORING ORGANIZATION	
6c. ADDRESS (City, State, and ZIP Code) Air Force Institute of Technology Wright-Patterson AFB, OH 45433-6583		7b. ADDRESS (City, State, and ZIP Code)	
8a. NAME OF FUNDING/SPONSORING ORGANIZATION AF Wright-Aero. Prop. Lab Adv. Plasma Research Gp.	8b. OFFICE SYMBOL (If applicable) AFWAL/PCOC-3	9. PROCUREMENT INSTRUMENT IDENTIFICATION NUMBER	
8c. ADDRESS (City, State, and ZIP Code) Air Force Wright-Aero. Propulsion Lab Wright-Patterson AFB, OH 45433-5000		10. SOURCE OF FUNDING NUMBERS	
		PROGRAM ELEMENT NO.	TASK NO.
		PROJECT NO.	WORK UNIT ACCESSION NO.
11. TITLE (Include Security Classification) ELECTRON TEMPERATURE MEASUREMENTS IN AN ARGON/CESIUM PLASMA DIODE (UNCLASSIFIED)			
12. PERSONAL AUTHOR(S) Ward, Michael J., B.S., 2d Lt, USAF			
13a. TYPE OF REPORT MS Thesis	13b. TIME COVERED FROM _____ TO _____	14. DATE OF REPORT (Year, Month, Day) 1987 December	15. PAGE COUNT 71
16. SUPPLEMENTARY NOTATION			
Approved for Public Release: 1997 APR 13 Lynn E. Wolaver Dean for Research and Professional Development Air Force Institute of Technology (AFIT)			
17. COSATI CODES		18. SUBJECT TERMS (Continue on reverse if necessary and identify by block number)	
FIELD	GROUP	SUB-GROUP	
20	9	Plasma Diagnostics, Electric Discharge, Cesium, Spectroscopy, Spectral Lines, Argon, Electron Energy	
19. ABSTRACT (Continue on reverse if necessary and identify by block number) Thesis Chairman: William F. Bailey, Professor of Physics. Line intensity measurements in an argon/cesium plasma diode were made at various locations within the discharge, yielding a spatially resolved electron temperature distribution. This device operated at 0.9 Torr argon, 0.04 Torr cesium, and at a current density of 1.05 mA/cm <sup>2</sup> . Observations of the spectral line intensities of the 6P→nS and 6P→nD transitions of cesium yielded an average electron temperature of 8200 K throughout most of the discharge region. In contrast, the argon line emission data yields an average electron temperature of 13500 K. The difference between these two measured "electron temperatures" suggests that the electron energy distribution function is non-Maxwellian under the measured plasma conditions			
20. DISTRIBUTION/AVAILABILITY OF ABSTRACT <input checked="" type="checkbox"/> UNCLASSIFIED/UNLIMITED <input type="checkbox"/> SAME AS RPT. <input type="checkbox"/> DTIC USERS		21. ABSTRACT SECURITY CLASSIFICATION Unclassified	
22a. NAME OF RESPONSIBLE INDIVIDUAL William F. Bailey		22b. TELEPHONE (Include Area Code) (513) 255-2012	22c. OFFICE SYMBOL AFIT/ENG

END

DATE

FILMD

3-88

DTIC