

AD-A189 359

IMPROVED OIL-OFF SURVIVABILITY OF TAPERED ROLLER
BEARINGS(U) TIMKEN CO CANTON OHIO G E KREIDER ET AL.
OCT 87 NASA-CR-188804 NASA-23689

1/1

UNCLASSIFIED

F/G 13/9

NL

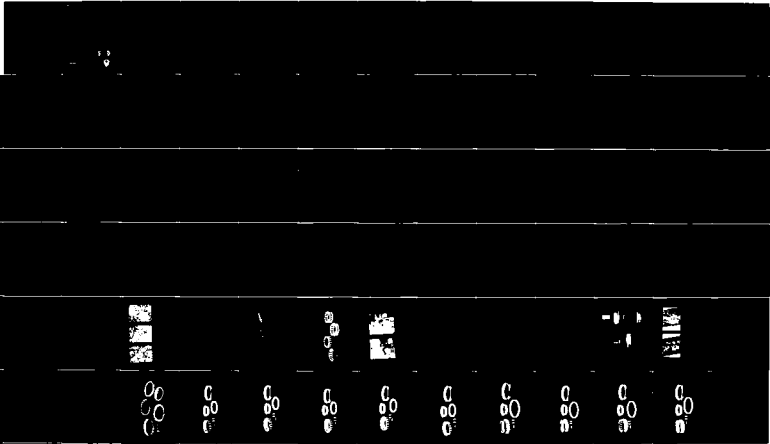

1
2
3
4
5
6
7
8
9
10

END
DATE
FILMED
3 8 8
DTI

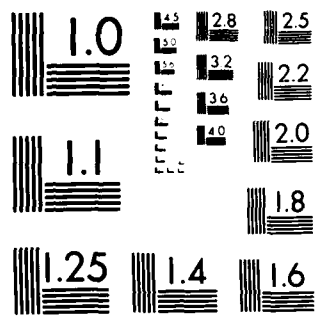

MICROCOPY RESOLUTION TEST CHART
NATIONAL BUREAU OF STANDARDS-1963-A

DTIC FILE COPY



NASA
Contractor Report 180804

AVSCOM
Technical Report 87-C-29

AD-A189 359

**Improved Oil-Off Survivability of
Tapered Roller Bearings**

G.E. Kreider and P.W. Lee
The Timken Company
Canton, Ohio

October, 1987

Prepared for the
Lewis Research Center
Under Contract NAS3-23689

NASA

National Aeronautics and
Space Administration

DTIC
ELECTE
DEC 31 1987
S **D**
E



87 12 22 091

This document has been approved
for public release and sale its
distribution is unlimited

Product Development - Bearings
Application Testing - Research

Contract Number NAS3-23689
Project Number 81035
Final Report

IMPROVED OIL-OFF SURVIVABILITY OF
TAPERED ROLLER BEARINGS

by
G. E. Kreider
P. W. Lee

September 8, 1987

Keywords: Tapered Roller Bearing, Ribbed Cup, Ribbed Cone, VIMVAR CBS600,
Powder Metal, CBS1000M, M2 High Speed Steel, Oil-Off Survivability,
Minimum Oil Flow, Porosity, Reduced Density Powder Metal

This document has been approved
for public release and sale; its
distribution is unlimited.

Forward

This program was performed under NASA Contract NAS3-23689. The NASA project managers were Mr. R. J. Parker succeeded by Mr. H. W. Scibbe succeeded by Mr. H. H. Coe.

Accession For		
NTIS GRA&I	<input checked="" type="checkbox"/>	
DTIC TAB	<input type="checkbox"/>	
Unannounced	<input type="checkbox"/>	
Justification		
By _____		
Distribution/ _____		
Availability Codes		
Avail and/or		
Dist Special		
A-1		

Table of Contents

	Page
Summary	1
Introduction	2
Background and Related Work	2
Scope	5
Materials Tested	6
Bearings Tested	11
Test Apparatus	13
Test Procedure	14
Results and Discussion	17
Summary of Results	26
References	28

Tables I - XXIV

Figures 1 - 31

List of Tables

Table

I	Chemical Analysis of CBS1000M, M2 H.S.S. and T15 H.S.S.
II	Particle Size Distribution
III	Bearing Material and Specifications
IV	Data Acquisition - Instrumentation
V	Bearings Tested and Serial Numbers
VI	Spring Rates of Helicopter Transmissions
VII	Bearing Stress Survey SI Units
VIII	Bearing Stress Survey English Units
IX	Test Bearing Loads, Stress and FV Coefficients
X	Material Screening Test Results
XI	Performance Data of Ribbed Cone TSMR-S M2 H.S.S. 65% Density
XII	Performance Data of Ribbed Cone TSMR-S CBS1000M 65% Density
XIII	Performance Data of Ribbed Cone TSMR-S CBS1000M 75% Density
XIV	Performance Data of Ribbed Cup TSRC-S M2 H.S.S. 65% Density
XV	Performance Data of Ribbed Cup TSRC-S CBS1000M 65% Density
XVI	Performance Data of Ribbed Cup TSRC-S CBS1000M 75% Density
XVII	Performance Data of Ribbed Cone TSMR VIMVAR CBS600
XVIII	Performance Data of Ribbed Cup TSRC VIMVAR CBS600
XIX	Performance Data of Ribbed Cone TSMA VIMVAR CBS600
XX	Performance Data of Ribbed Cup TSRC-ML VIMVAR CBS600
XXI	Oil-Off Test Results TSMR, TSMA, and TSMR-S
XXII	Oil-Off Test Results TSRC, TSRC-ML, and TSRC-S
XXIII	Microhardness of Rib Ring
XXIV	Retained Austenite in Rib Rings Determined by X-Ray Diffraction

List of Figures

Figure

- 1 Compacting Curve for Annealed CBS1000M Steel Powder
- 2 Compacting Curve for Commercially Available Annealed M2 High Speed Steel Powder
- 3 Compacting Curve for Annealed T15 High Speed Steel Powder
- 4 Typical Pore and Carbide Distribution of the Pressed, Sintered, Hardened, and Tempered Wear Test Blocks
- 5 Test Bearing Styles
- 6 EX1292AB TSRC-ML Cage
- 7 EX1292AB Cages with Microporous Polymer Lubricant and EX1292AC Standard Cage
- 8 Timken Lubricant and Wear Test Machine
- 9 Test Rig Cross Section
- 10 Lubrication System for the Test Rig
- 11 Data Acquisition Flow Chart
- 12 Test Block Condition of (a) CBS1000M Block With CBS600 Ring, (b) Silicon Nitride Test Block With CBS600 Ring, (c) Standard Case Carburized Bearing Material
- 13 Damaged CBS1000M 65% Rib Number 84-77 and Rib Number 84-78
- 14 JEX1292CE, TSRC, CBS600 Cup Rib Wear
- 15 JEX1292CF, TSRC-S, M2 H.S.S. 65% Density Cup Rib Wear
- 16 JEX1292CF, TSRC-S, CBS1000M 65% and 75% Cup Rib Wear
- 17 Temperature and Torque vs. Flow Rate at 24,000 rpm, CBS1000M 75% Density and CBS600 Ribbed Cup
- 18 JEX1292CD, TSMR-S, CBS1000M 75% Density Damaged at 37,000 rpm (2.4 Million DN)
- 19 JEX1292CC, TSMR, CBS600, 8.3 Minutes Oil-Off at 11,000 rpm (0.72 million DN)
- 20 JEX1292CD, TSMR-S, M2 H.S.S. 65% Density, 7.1 Minutes Oil-Off at 11,000 rpm (0.72 million DN)

- 21 JEX1292CD, TSMR-S, CBS1000M 65% Density, 12.8 Minutes Oil-Off at 11,000 rpm (0.72 million DN)
- 22 JEX1292CD, TSMR-S, CBS1000M 75% Density, 12.4 Minutes Oil-Off at 11,000 rpm (0.72 million DN)
- 23 JEX1292CD, TSMR-S, CBS1000M 65% Density, 5.1 Minutes Oil-Off at 17,000 rpm (1.1 million DN)
- 24 JEX1292CF, TSRC-S, M2 H.S.S. 65% Density, 22.1 Minutes Oil-Off at 12,000 rpm (0.78 million DN)
- 25 JEX1292CF, TSRC-S, CBS1000M 65% Density, 18.1 Minutes Oil-Off at 12,000 rpm (0.78 million DN)
- 26 JEX1292CF, TSRC-S, CBS1000M 75% Density, 11.2 Minutes Oil-Off at 12,000 rpm (0.78 million DN)
- 27 JEX1292CF, TSRC-S, CBS1000M 65% Density, Electro-Etched Rib Face Oil-Off at 12,000 rpm (0.78 million DN)
- 28 Oil-Off Temperature and Torque vs. Time at 11,000 rpm (0.72 million DN) TSRC-S CBS1000M 65% Density
- 29 Oil-Off Temperature and Torque vs. Time at 12,000 rpm (0.78 million DN) TSRC-S CBS1000M 65% Density
- 30 CBS1000M P/M Rib Ring After Oil-Off Test
- 31 CBS1000M P/M Rib Ring After "Break-In" Test

SUMMARY

The objective of this effort is to develop a tapered roller bearing and/or lubrication requirement that would provide 30 minutes of satisfactory operation after the oil supply was shut-off. This oil-off condition is to be performed while running under typical loads from a helicopter transmission input pinion gear and at speeds to 2.4 million DN. This program was to apply to a tapered roller bearing a fabricated powder metal rib ring with a reduced density containing a residual oil supply to lubricate the roller large end/rib face conjunction when the external oil supply was lost.

A preliminary screening study of powder metal materials, densities, coatings, and treatments was conducted in a Timken Lubricant and Wear Machine. The candidate materials were CBS1000M at 65%, 75%, and 85% density; M2 high speed steel at 65%, 75%, and 85% density; T15 high speed steel at 65%, 75%, and 85% density; M2 high speed steel with 5% copper at 65% density; M2 high speed steel with 5% MoS₂ at 75%; M2 high speed steel with ion nitrides, PSZ (partially stabilized zirconia) at 98% density; and silicon nitride with aluminum oxide at 89% density. Three of the candidate materials were selected for continued evaluation of bearing components. The three materials, CBS1000M at 65%, CBS1000M at 75%, and M2 high speed steel with Cu at 65% densities, were then used to fabricate rib rings for use in a tapered roller bearing. The rib rings were evaluated at six speeds from 0.26 million DN to 2.4 million DN for the 65 mm (2.6 inch) bore bearing of a ribbed cone and a ribbed cup design. The performance of the powder metal components were compared with the performance of VIMVAR CBS600 as the standard material. The VIMVAR CBS600 was also used for the raceways, rollers, and ribs.

The powder metal components were compacted, sintered, heat treated, ground, etched in Vilella's etch to remove the Bielby layer (grinding smear), then oil impregnated. The Vilella's etch was a tedious procedure which required the powder metal rings to be dry ground, keeping the grinding coolant out of the porous rings. This dry grinding can retemper the surface, resulting in a loss of hardness. At the end of the program, an alternate electro-etch technique was used which allowed the rib rings to be ground using a coolant since the rib ring can be impregnated with oil prior to grinding. The oil in the rib ring does not have an adverse effect on the electro-etch method.

The bearing tests with normal lubrication indicated surface damage of a few ribs at speeds above 24,000 rpm (1.6 million DN) as a result of grinding dry and retempering. Minimum oil flow requirements were also established for speeds up through 2.4 million DN for both the ribbed cone style and ribbed cup

style bearings. At 30,000 rpm (2.0 million DN) the ribbed cone was operated with 0.2 L/min (0.5 pt/min) to the small end of the roller and 1.7 L/min (3.5 pt/min) through the inner race to the large end of the roller. The ribbed cup bearing was operated at 30,000 rpm (2.0 million DN) with 1.2 L/min (2.5 pt/min) of oil to the small end of the roller. The outer race temperatures of the ribbed cone and ribbed cup at these conditions were 448°K (346°F) and 477°K (399°F) respectively.

The "standard" bearing oil-off performance was 10 minutes at 4,000 rpm (0.26 million DN). The oil-off tests showed the ribbed cup bearing with the powder metal cup rib to be the style having the longest lives. The ribbed cup style achieved the 30 minute goal at 11,000 rpm (0.72 million DN) for the M2 65% and CBS1000M 75% material while the ribbed cone achieved only 7.1 minutes and 12.4 minutes for the same materials respectively. The CBS1000M 65% density cup rib survived for 10 minutes at 13,000 rpm (0.84 million DN); however, at speeds from 17,000 rpm (1.1 million DN) through 37,000 rpm (2.4 million DN) the oil-off bearing lives were generally only a few seconds.

The ribbed cup tapered roller bearing with a powder metal rib made to a reduced density of 65% or 75% can operate at 11,000 (0.72 million DN) for 30 minutes without an external supply of oil.

The residual oil impregnated into the cup rib and cone rib will bleed out to the roller end/rib conjunction through capillary action initiated by the thermal effect and the difference in the coefficient of thermal expansion of the oil and the powder metal rib.

INTRODUCTION

Background and Related Work

Since the late 1960's, The Timken Company has been actively developing technology and manufacturing tapered roller bearings for high speed aircraft applications. The first object was to increase speed capabilities. The objectives achieved progressively increased from 1.5 million DN to 3.5 million DN. At the higher speeds existing, cage designs were shown to be insufficient. New cage designs meet operational requirements. Coincident with these efforts, materials and processes were refined with high temperature capabilities, fatigue resistance, and fracture toughness. Further design flexibility has been demonstrated with integral shaft/inner race designs and ribbed cups.

Portions of these R & D programs were addressed to meeting the military requirement of 30 minutes of normal transmission operation after loss of lubricant supply. In these cases, the work was a sub-task or extension, cursory in nature and performed with existing bearing specimens and test rigs.

The objective being to measure survivability rather than to improve. The test configurations produced extremely adverse interactions between bearing and housing/shaft systems. This present program focused on improving oil-off survivability under realistic operating conditions.

Oil-off survivability of helicopter transmission systems for 30 minutes has been a long sought goal by the military. Two approaches have been used in seeking to achieve this requirement. One has been to design into the system an auxiliary source that would provide minimal lubrication following oil supply interruption. This lubricant could either be supplied continuously or activated by changes in various performance parameters. The other approach has been to design into the bearing a greater tolerance to operate under extreme lubrication starvation conditions. Whether either of these methods provide a 30 minute fail-safe helicopter transmission system has not been established. Clearly the ball, spherical, and cylindrical bearing designs to-date have shown longer operating times.

Beginning in 1968, The Timken Company undertook research programs to develop high speed tapered roller bearings to support spiral bevel gearing in advanced helicopter transmissions and drive systems. The first of these programs evaluated high speed tapered bearing performance to 1.42 million DN (diameter of bore in mm x speed in rpm), fail safe materials applied to the cone ribs, roller spherical end radii and the cages [Ref. 1]. The second program evaluated a high speed tapered bearing at 1.78 million DN for support of spiral bevel gearing for a Heavy Lift Helicopter aft and combining transmission [Ref. 2].

In the early 1970's, the National Aeronautics and Space Administration Lewis Research Center began a sequence of research programs directed toward extending the speed and performance capabilities of tapered roller bearings. These programs showed the influence of bearing design parameters and materials. Successful performance was achieved up to 2.4 million DN, and endurance lives up to 24 times the rated catalog life were reported for this 120.6 mm (4.75 in.) bore bearing.

In 1972, Timken was awarded a sequence of two contracts under the sponsorship of AFAPL, Wright-Patterson Air Force Base. The first three years sought to investigate the feasibility of operating tapered roller bearings under future gas turbine engine requirements of speed and load. Performance at 3.5×10^6 DN and a 22.2 kN (5000-lb) thrust load were set as goals. A bearing with a 107.95 mm (4.250 in.) bore and a 146.05 mm (5.75 in.) outer diameter (O.D.) was chosen for that program. Test results [Ref. 3] showed that tapered roller bearings were capable of operating at high speeds and high loads. The test program also showed that additional development would be required to provide a cage with sufficient strength to eliminate the plastic deformation of the cage under the high-inertia loading.

The objective of the second contract (1976-1979) was to enhance the state of the art of ultra-high-speed tapered roller bearings. The three tasks successfully accomplished were (1) the development of a reliable cage design for 3.5 million DN service; (2) the definition of bearing performance as related to lubrication effects, heat generation, and 30-sec oil-off survival; and (3) the experimental determination of fatigue life at 3 million DN. A final technical report covering this second contract is numbered AFAPL-TR-79-2007 [Ref. 4].

In mid 1977, Timken became a subcontractor for the Vertol Division's "Advanced Input Bevel Pinion Tapered Roller Bearing Development Program" under the sponsorship of the U.S. Army, Applied Technology Laboratory (ATL) [Ref. 5]. The program objective was to design, fabricate, and demonstrate an input bevel tapered roller bearing for an advanced concept helicopter transmission.

From 1972 to the present, The Timken Company has been actively investigating materials as possible candidates for tapered roller bearing oil-off survival conditions. This work has given the insight to develop safe, high speed, tapered roller bearings. Within the framework of the program plan, the first priority would be the rib-roller spherical end conjunction. Secondly, the cage designs would be enhanced considering the guided surfaces and structural strength. A third aspect would be to include a material within the bearing envelope that would lubricate upon demand the rolling conjunctions.

The Timken Company has invented a porous powder metal material, "having pores that are exposed at the surface against which the large ends of the rollers bear, so that the rib ring will absorb a lubricant and release it to lubricate the roller ends when the bearing loses its normal supply of lubrication." Extracted from U.S. Patent number 4,601,592 [Ref. 6].

The initial test results of the powder metal material indicated a valid concept was at hand. This concept of utilizing a reduced density powder metal bearing material for tapered bearing ribs was the main issue addressed in this program. The program consisted of evaluated numerous powder metal candidates in a friction and wear condition without external lubrication, then apply these results to a bearing rib for evaluation in a simulated helicopter transmission environment.

SCOPE

The program was comprised of seven tasks. An overview of the program tasks is shown below.

Task I	Preliminary Screening Study
Task II	Bearing Design and Fabrication
Task III	Test Rig Preparation
Task IV	Performance - Normal Lubrication
Task V	Minimum Lubrication/Oil-Off Tests - Conventional Design
Task VI	Minimum Lubrication/Oil-Off Tests - Survivable Design
Task VII	Monthly Report/Final Report

Task I was the preliminary screening study of processes, coatings, and P/M (powder metal) material that will allow the rib-roller end conjunction to operate 30 minutes without lubricant supply. The three leading performers, CBS1000M 65%, CBS1000M 75%, and M2 high speed steel 65% density levels were selected for full scale bearing tests out of 17 combinations of candidates [Ref. 7]. Task II, Bearing Design and Fabrication, consisted of the design of two styles of bearings from the same base bearing series 29500. A ribbed cone (inner race) and ribbed cup (outer race) bearing was designed to evaluate the performance of each style.

There were two prime reasons for selecting this series. The internal geometry is near optimum for a 65 mm (2.56 inch) bore high speed helicopter transmission bearing application. It was readily available in a standard commercial design. The rig design and rig preparation was Task III, which included the study of existing helicopter transmission designs to establish housing stiffnesses to utilize in the test housing. These characteristics were then designed and fabricated into the test housing at the position where the oil-off bearing would be tested.

Task IV was the performance test of the survivable design bearings with normal lubrication. This task was the shakedown for the test machine and the evaluation of the bearings' performance with the powder metal ribs and cage pilots. The ribbed cone and ribbed cup style bearings were evaluated in this task.

The minimum lubrication and oil-off tests for the conventional steel ribbed cone and ribbed cup bearings were tested in Task V. The minimum lubrication was supplied and monitored through flow meters located in the oil supply lines. The oil-off tests were accomplished by solenoid valves in the supply lines that were remotely controlled to stop the lubricant flow.

Task VI was the testing of the survivable design for minimum oil flow and oil-off. The ribbed cup and ribbed cone style bearings were tested using powder metal ribs made from M2 H.S.S. to a 65% density and CBS1000M high temperature steel to a 65% and 75% density level.

Task VII is the reporting phase of the program. Monthly status and financial reports throughout the program were submitted.

MATERIALS TESTED

Task I - Preliminary Screening Study

1. Material Selection

The following materials with various density levels (65%, 75%, and 85% of theoretical density) were selected for a screening study to evaluate candidate materials with the Timken lube test machine.

- A. CBS1000M at 65%, 75%, and 85% density
- B. M2 high speed steel at 65%, 75%, and 85% density
- C. T15 high speed steel at 65%, 75%, and 85% density
- D. PSZ (partially stabilized zirconia) at 98% density (Two grades, MS and TS)
- E. M2 with 5% copper at 65% density
- F. M2 with 5% MoS₂ at 75% density
- G. CBS1000M with TiC and TiN coating
- H. M2 with TiC and TiN coating
- I. CBS1000M with ion nitriding
- J. Silicon nitride 89% density

2. Powder Preparation

A. CBS1000M Powder

A 454 kg (1000 lb.) batch of CBS1000M powder was water atomized by Metallurgical Industries, Inc., Tinton Falls, New Jersey. As atomized powder was cleaned by a linear motor cleaner at Latrobe Steel Company (wholly owned subsidiary of The Timken Company).

The powder was batch annealed at Timken Research in a vacuum furnace with the following cycle for 22.7 kg (50 lbs.) of powder:

1. 13 hours to complete outgassing
2. 4 hours at 1255°K (1800°F)
3. 8 hours to cool to 1005°K (1350°F)
4. Hold for 15 hours at 1005°K (1350°F)
5. 9.5 hours to cool to room temperature

Note: All data measurements were taken in English units for this program then converted to SI units for the report.

The chemical analyses including oxygen level and particle hardness are given in Table 1. CBS1000M powder was blended with 0.5% by weight of graphite powder and 1.0% of Acrawax C powder.

B. M2 High Speed Steel Powder

A 45.4 kg (100 lbs.) batch of water atomized and fully annealed powder was purchased from Glidden Metals Division of SCM Corporation. The chemical analyses including oxygen level are given in Table I. M2 powder was blended with 0.2% graphite and 1.0% of Acrawax C powders.

C. T15 High Speed Steel Powder

A 45.4 kg (100 lbs.) batch of water atomized and fully annealed powder was purchased from Glidden Metals Division of SCM Corporation. The chemical analyses are given in Table I. T15 powder was blended with 0.3% of graphite and 1.0% Acrawax C powders.

3. Compaction

Three powders were compacted into 31.8 mm x 12.7 mm x 12.7 mm (1.25 in. x 0.5 in. x 0.5 in.) blocks with 65%, 75%, and 85% of theoretical density levels. Compacting load was selected from the compactability curves shown in Figures 1 to 3 for CBS1000M, M2 high speed steel, and T15 high speed steel, respectively. The powder metal particle size distribution is shown for the three materials in Table II.

4. Delubrication and Sintering

All the blocks were delubricated at 1033°K (1400°F) for 20 minutes under a nitrogen atmosphere in a 152 mm (6 in.) tube furnace. The delubricated blocks were then sintered at 1394°K (2050°F) for 30 minutes in a vacuum furnace.

5. Heat Treatment and Oil Impregnation

Each test block was hardened and tempered according to the following procedures.

A. CBS1000 Steel

1. Preheat to 1061°K (1450°F), then raise to 1366°K (2000°F) in vacuum and hold for 10 minutes maximum.
2. Quench in N₂.
3. Wrap sample with metal foil.
4. Cold treat at 194°K (-110°F) for 2 hours within 4 hours of hardening.
5. Unwrap sample.
6. Triple temper at 811°K (1000°F) for 2 + 2 + 2 hours in vacuum.
7. After third 811°K (1000°F) temper, specimen should be cooled in a vacuum to room temperature and then coated with neutral oil.

B. M2 High Speed Steel

1. Preheat to 1061°K (1450°F) in vacuum for 30 minutes, then raise to 1464°K (2175°F) and hold for 5 minutes.
2. Quench in N₂.
3. Double temper at 811°K (1000°F) for 2 + 2 hours in vacuum.
4. After second 811°K (1000°F) temper, specimen should be cooled in a vacuum to room temperature and then coated with neutral oil.

C. T15 High Speed Steel

1. Preheat to 1061°K (1450°F), then raise to 1491°K (2225°F) in vacuum and hold for 10 minutes.
2. Quench in N₂ gas.

3. Wrap sample with metal foil.
4. Cold treat at 194°K (-110°F) for 2 hours.
5. Unwrap sample.
6. Triple temper at 811°K (1000°F) for 2 + 2 + 2 hours in vacuum.
7. After third temper, specimen should be cooled in a vacuum to room temperature and then coated with neutral oil.

Particle hardness after heat treatment ranged from 61 to 63 HRC for all the steel types. Microstructures for both M2 and T15 high speed steel powder showed tempered martensite with finely distributed carbide particles. CBS1000M powder showed tempered martensite with very few carbide particles. All three powders showed an insignificant amount of the retained austenite. Typical microstructures for three steel types are given in Figure 4.

PSZ (Partially Stabilized Zirconia) Test Specimens

The PSZ material was supplied by Nilsen (U.S.A.), Glendale Heights, Illinois, a member of the Nilsen Industrial Group, Melbourne, Australia. The 38.1 mm x 12.7 mm x 12.7 mm (1.5 in. x 0.5 in. x 0.5 in.) test specimens were cut from a solid block compacted by Nilsen. The PSZ was 98% dense and was supplied in a MS grade (maximum strength and wear resistant) and a TS grade (maximum thermal shock resistant).

Silicon Nitride

The silicon nitride material was manufactured by Greenleaf Carbide Corporation, Sagertown, Pennsylvania. The material was compacted to a theoretical density of 89%. The proportion of the aluminum oxide additive is considered proprietary by the Greenleaf Carbide Corporation.

CBS600 Test Rings

The test rings were manufactured from Vacuum Arc Remelted (VAR) CBS600 steel by the Faville-LaVally Corporation, Aurora, Illinois. The steel was manufactured by The Latrobe Steel Company and shipped to Faville-LaVally Corporation.

Control Test Blocks and Rings

Test blocks (SAE 4319 steel) and test cups (SAE 8720 steel) were case carburized and hardened, and were tested to use as the control block.

Test rings made from case carburized SAE 8720 steel were tested as the control material.

Test Block Preparation

The powder metal block specimens were prepared for test by the following procedure:

1. Grind to size on a rotary grinder.
2. Ultrasonically clean in 1,1,1-trichloroethane and allow to dry.
3. Ultrasonically etch in Vilella's Etch:

Composition of Vilella's Etch - 5 mL HCL
1 gm Picric Acid
100 mL Ethyl Alcohol

The etch time can vary from one material to another. The Vilella's Etch was used to remove the Bielby Layer (grind smear) and open the pores of the blocks. The blocks were etched in two minute cycles to establish the total etch time.

4. Ultrasonically rinse in distilled or deionized water.
5. Ultrasonically rinse in sodium carbonate (Na_2CO_3) and distilled or deionized water solution.
6. Ultrasonically rinse in clean distilled or deionized water.
7. Place in an oven heated to 422°K (300°F) until completely dry throughout.
8. Soak in the type of lubricant for test at 422°K (300°F).
9. Allow to cool to room temperature in the oil bath.

Two separate lubricants were impregnated into the powder metal blocks: 1) a Mil-L-23699 qualification oil, and 2) Borate 9150, a high temperature EP additive manufactured by Chevron Research Company.

BEARINGS TESTED

The bearings were tested in Task IV through Task VI. The types of bearings tested with the particular component material are shown in Table III. The bearing styles TSMA and TSMR are ribbed cone designs, while the TSRC are ribbed cup styles. The bearing styles are shown in Figure 5. The TSMA ("standard") bearing style is a ribbed cone with axial lubrication holes through the cone rib. The TSMR and TSMR-S are a ribbed cone style bearing designed for high speed operation. This bearing style has radial holes through the inner race for lubricating the roller end/rib contact. The TSRC and TSRC-S are a ribbed cup style bearing designed for high speed operation. The "-S" signifies the survivable designs using powder metal ribs and cage pilots.

The bearing races were made from VIMVAR CBS600, a high temperature case carburized material capable of operating at sustained temperatures up to 505°K (450°F). The cage pilot and the cup and cone ribs for the survivable designs were manufactured from two powder metal materials: M2 high speed steel to a 65% theoretical density level, and CBS1000M steel to a 65% and 75% theoretical density level. The cage pilot and ribs were of the same material for a given bearing. The cages in all tests were silver plated to Federal Specification QQ-S-365C. The cages were machined from AMS6414C (SAE 4340) steel, except for the cage on the TSMA style which was extruded from an SAE 1010 steel. The six variations of bearings were designed and manufactured to common internal dimensions as shown on Table III.

The TSRC-ML bearing was fabricated using a modified cage to inject a microporous polymer lubricant into specially drilled holes, as shown in Figure 6. These holes broke out of the cage to provide lubricant to the critical areas in the bearing. Cages EX1292AB with the microporous polymer lubricant are shown in Figure 7 along with a standard cage EX1292AC.

The microporous polymer lubricant (MPL) is a solid polymeric material containing interconnecting microscopic pores which are filled with liquid lubricants, in this case, Mil-L-23699. The oil was dispensed to the bearing surfaces under the influence of the centrifugal forces, the elevated temperatures at the higher speeds, and also by capillary action. A 50/50 ratio of microporous polymer lubricant and Mil-L-26399 oil was used in the cage cavity. This ratio was established by the injection parameters of the polymer, catalyst, and oil compatibility. The polymer and catalyst materials were obtained from United Lubricants Corporation, Denver, Colorado. The oil used in this program was a qualified Mil-L-23699 purchased from the Mobil Oil Company. Throughout the test program, the oil was supplied to the bearings at 335°K (180°F).

Powder Metal Components

The powder metal cone ribs, cup ribs, and cage pilots were manufactured from CBS1000M powder and M2 high speed steel powder. These components were compacted into rings, sintered and heat treated using the processes described in Task I - Preliminary Screening Study. The grinding of these powder metal components was done without a coolant to eliminate contamination into the porous material.

The powder metal ribs were prepared for testing using the same acid etch technique as the test blocks in the screening study of Task I. Near the end of the program, a second etching technique known as electro-etching, was used to remove the Bielby layer (grinding smear) from the ribs. The Bielby layer is the grind smear that is generated by the grinding of the component. The procedure for the electro-etching is as follows:

1. After grinding, the ribs are cleaned ultrasonically in ethanol.
2. Electro-etch in a Perchloric acid solution.

Composition of Perchloric acid solution:

70% Ethanol
6.2% Perchloric acid
10.0% Butyl cellulosive
13.8% H₂O

The etch time can vary depending on the current density of the electric field.

3. Ultrasonically rinse in ethanol alcohol.
4. Rinse in clean distilled or deionized water.
5. Place in an oven at 422°K (300°F) until completely dry.
6. Soak in the Mil-L-23699 in a vacuum to impregnate the oil into the ribs.

The electro-etching technique produced better uniform pores with a shorter etching time. It also allowed the rib rings to be oil impregnated prior to grinding and ground with a coolant since the oil in the rib ring does not have an adverse effect on electro-etching process.

TEST APPARATUS

Task I - Preliminary Screening Study

The screening tests for the candidate materials were performed on a modified and instrumented Timken Lubricant and Wear Test Machine (shown in Figure 8). This machine has a well established procedure and has been used by The Timken Company over the past decade for similar studies. In a tapered roller bearing, the relative motion between the rib and roller spherical end is a combination of rolling and sliding. The Timken Company machine is not capable of duplicating this condition; however, two important parameters can be simulated — sliding velocity and Hertzian stress. The machine principle is to impose a rotating ring on the specimen stationary block under a constant 520 Newton (117 lb.) normal contact load.

Task IV Through Task VI - Bearing Testing

A universal high speed tapered roller bearing radial and thrust load test machine was used in this test program. It was originally designed and fabricated specifically for development testing of high speed tapered roller bearings for advanced helicopter transmissions and drive systems.

The test shaft is driven by a 93 KW (125 HP) D.C. electric motor at 2,500 rpm coupled to a 15.225:1 ratio speed increaser. This results in a maximum test shaft speed of 38,000 rpm.

The test head cross section is shown in Figure 9. A hydraulic load cylinder is located centrally on top of the housing to apply a radial load to the two center slave bearings. This load is transmitted through the shaft assembly to the test bearing oil-off position and the third slave. These bearings are equally spaced from the center so that each carries half the applied load to the center slave bearings. Thrust load is applied hydraulically to the shaft. This assembly is shown mounted on the test housing in test head cross sectional drawing.

The lubrication system for the machine is schematically shown in Figure 10. One portion of the system supplies oil to the test bearing as well as to the three slave bearings for lubrication and temperature control. The second portion of the system, with separate pumps and reservoir, supplies oil to the speed increaser for lubrication of the gearbox bearings and gears.

The pump used on the test rig side of the system is capable of supplying 114 liters per minute (30 gallons per minute) to the housing. The temperature of the oil is controlled by a water cooled heat exchanger for cooling and an in-line heater for heating. Five delivery branches supply oil to the housing. Three branches supply oil to the test bearing and are equipped with electric solenoid valves for oil shut off. The remaining two branches supply oil to the slave bearings. All branches are equipped with flow control valves and turbine type flow meters. High temperature materials (such as stainless steel), closures, and components were used throughout the system to prevent chemical reaction and contamination of the lubricant.

A computer-based automatic data acquisition and control system is used to measure and control bearing operating conditions as well as imposed test conditions. Table IV outlines the transducers and signal conditioning used for each type of measurement and the accuracy specification for each. The outputs of this instrumentation are multiplexed and measured by a Hewlett Packard 3497A data acquisition/control unit. This unit is interfaced with a Hewlett Packard 226 desktop computer. Software on the 226, written in-house by The Timken Company in the basic language, is used to control the scanning process, to read and compare data to preset limits, and to record data on magnetic tape. The flow chart in Figure 11 outlines how this software is organized. In the event that a test parameter exceeds the preset limit, this system will automatically shutdown the drive motor. This system was able to record the primary test parameters of torque and bearing temperatures once every 1.3 seconds.

TEST PROCEDURE

Task I - Preliminary Screening Study

The Timken Lubricant and Wear Test Machine was modified to monitor spindle rpm and torque that was recorded on a strip chart recorder.

Oil-off survival tests were conducted using the following standardized procedure.

1. The test block specimen was mounted in the machine lever load arm and squarely contacted the test ring outside diameter.
2. The test block/test ring interface was flooded with Mil-L-23699 oil (Mobil Jet II) at 311°K (100°F) inlet temperature.

3. The machine spindle, strip chart recorder, and stopwatch were started simultaneously. The spindle speed was maintained to provide a ring outside diameter velocity of 186 m/min (611 ft/min).
4. A 4.45 Newton (1 lb) load was applied to the lever load arm in one minute intervals until a total lever load of 44.5 Newton (10 lb) was achieved. This resulted in an initial Hertzian stress of 239 MPa (34,700 psi) for porous powder metal blocks and steel rings.
5. The test block was "run-in" for 10 minutes under full load and flooded lubrication to establish a baseline torque.
6. At the end of 10 minutes, the lubricating oil flow was shut off, and residual oil was purged by means of an air line directed at the block/ring interface. Simultaneously, the residual oil was wiped from the ring outside diameter using an absorbent cloth. Initially a 620 kPa (90 psi) air purge was used; however, this was changed to 68.9 kPa (10 psi) to be more realistic for a bearing application.
7. The oil-off survival time is the duration from oil-off until an observed torque of 1.13 N·m (10.0 lbf·in) greater than the baseline torque value is reached. In the cases when the oil-off survival time reached 240 minutes, the test was suspended.

Task II - Bearing Design and Fabrication

The 29500 series bearing was the basic design for the tapered roller bearing used in this program. The bearing internal geometry was maintained with design changes only to the external geometries for the ribbed cone and ribbed cup designs. Prior to establishing the design of the separable ribs, the design of the machined cage was accomplished. The cage was designed using the analytical equations established by The Timken Company. The bearings tested in this program are tabulated in Table V showing the type of bearing and the serial number of the component cone, cup, and rib.

Task III - Test Rig Preparation

The initial phase of this task was to review current helicopter transmission system designs, predicting how they would react thermally and elastically at oil-off. The calculated spring rates of these helicopter housings is shown on Table VI, the company names and models of the helicopters are not shown for proprietary reasons. Secondly, these characteristics were designed into the test machine housing adapter at the oil-off position, as shown in Figure 9.

Task IV - Performance Test - Normal Lubrication

The TSMR-S and TSRC-S (survivable) bearings were evaluated in this task with normal lubrication. The shakedown of the rig was also a part of this task.

The loads at each speed level were determined by a survey of existing helicopter bearing applications. Tables VII and VIII show these contact stresses for the SI and English units respectively, from which the test loads were determined. The speeds, thrust and radial loads, and rib stress for the bearings tested in this program are tabulated in Table IX.

The procedures for testing remain the same throughout the bearing evaluation tests of Task IV through Task VI. The bearings were run-in prior to recording bearing performance data. The operating speeds and PV (pressure velocity) values for the ribbed cone and ribbed cup styles for both the powder metal and standard material are shown in Table IX. The data for normal operation and oil-off was collected at 4,000, 11,000, 17,000, 24,000, 30,000, and 37,000 rpm. Through the course of testing, data was also recorded at 8,000, 12,000, and 13,000 rpm. The 12,000 and 13,000 rpm speeds were tested using the TSRC-S design when it became obvious that beyond 11,000 rpm the oil-off survivable time dropped off rapidly.

This normal lubrication task evaluated the powder metal components for performance in typical operation. The assemblies which were not damaged were used in subsequent tests of Task VI.

The TSRC-S bearings (powder metal cup ribs) were mounted at the outer positions of the test shaft and the TSMR-S (powder metal cone ribs) bearings at the inner positions, See Figure 9, showing the test head cross section.

Task V - Minimum Lubrication/Oil-Off Tests - Conventional Designs

The TSMR and TSRC bearings were operated at the speeds and loads indicated on Table IX. The bearings were run-in to the particular test speed for that run then maintained for a period of stable operation. The minimum lubrication requirement was established by reducing the oil flow to the test bearing by 0.47 liters/min (1 pt/min) until the operating temperature increased rapidly and the torque became unstable. From that point, the oil flow was reduced by 0.24 liters/min (0.5 pt/min) until the cup temperature exceeded 505°K (450°F) or the torque became unstable.

The oil-off test runs were conducted by establishing stable operating conditions of the test bearing then shutting off the flow of oil by utilizing a remote controlled valve. The oil-off tests were run until the bearing roller end/rib conjunction became severely scored. The termination of an oil-off run was either from a high temperature of the cup of a TSMR bearing, a cup rib of a TSRC bearing, or a torque limit. These temperature and torque limits were programmed into the computer. The limits are as follows:

	<u>Limit</u>
Cup O.D. Temperature	589°K (600°F)
Cup Rib O.D. Temperature	589°K (600°F)
Torque (test head)	20 N·m (180 lbf-in)

Task VI - Minimum Lubrication/Oil-Off Tests - Survivable Design

The same test procedure was followed for the survivable design as the conventional design tested in Task V. When it became obvious that the 30 minute oil-off goal was not possible at speeds of 17,000 rpm (1.1 million DN) or higher, a concentrated effort was made at 12,000 rpm (0.78 million DN) and 13,000 rpm (0.84 million DN) to determine a maximum speed that would still meet the 30 minute goal. The TSRC-S style bearing was tested at these two speeds based on the prior runs as showing the longest oil-off times. Included in the test runs at 12,000 rpm was the electro-etched CBS1000M 65% density cup ribs.

RESULTS AND DISCUSSION

Task I - Preliminary Screening Study

Task I consisted of selecting, preparing, and testing powder metallurgy and ceramic specimens to operate in a Timken Lubricant and Wear Test Machine in a screening study for selection of a material for future testing.

Table X is a summary of the results of the powder metal test specimens. The 17 combinations of materials, densities, air purge pressures, lubricants, and processes are summarized with respect to the length of time each specimen survived after the oil was shut off. A statistical analysis was used to select the materials which were used for bearing components in the latter tasks of the contract.

An oil-off time of 240 minutes was arbitrarily chosen as the maximum run time, when testing would be suspended.

One material, CBS1000M of 65% density survived 240 minutes for each of the three specimens using the 68.9 kPa (10 psi) air purge. A CBS1000M - 65% density test block which survived the 240 minute cutoff is shown in Figure 12(a). Three other materials approached the 240 minute cutoff which were CBS1000M - 75% density, CBS1000M - 85% density, and M2 with 5% copper - 65% density.

The M2 high speed steel with 5% copper compacted to 75% density achieved a 132.36 minute mean oil-off run time with the Borate additive. This candidate was not considered since a Borate additive to the lubrication system of a helicopter transmission or turbine engine may not be acceptable.

The silicon nitride test blocks did not accumulate time in the oil-off condition as a stabilized baseline torque could not be established. The test block surface and ring outside diameter were heavily scored when operating with flooded lubrication (See Figure 12(b)).

The test specimens in the screening study tested at the 620 kPa (90 psi) were not all retested at 69 kPa (10 psi) for all the specimens due to the results of these specimens and the availability of test specimens.

The case carburized SAE 4319 test block and SAE 8720 test ring also could not be torque stabilized with the flooded lubrication to establish a baseline torque. As with the silicon nitride specimen, heavy scoring occurred at the test ring/block contact (See Figure 12(c)).

The test blocks having the lower densities achieved the longest oil-off run times under the same test conditions. This result would be expected since the lower density specimens could hold more lubricant to be released in the oil-off conditions.

Based on the preliminary screening study, CBS1000M, 65% of theoretical density; CBS1000M, 75% of theoretical density; and M2 H.S.S. with 5% copper additive, 65% of theoretical density were selected as the three materials for additional survivability tests in full scale bearing tests.

Task IV - Performance Normal Lubrication/Survivable Design

The results of the test runs with normal lubrication, using the powder metal cone rib and cup rib bearing, are shown on the following tables:

<u>Table</u>	<u>Style</u>
XI	TSMR-S M2 65%
XII	TSMR-S CBS1000M 65%
XIII	TSMR-S CBS1000M 75%
XIV	TSRC-S M2 65%
XV	TSRC-S CBS1000M 65%
XVI	TSRC-S CBS1000M 75%

The input oil is directed to the TSMR and TSMR-S bearings at the small end (SE) of the roller via oil jets and to the large end (LE) of the roller and cone rib via the shaft and inner race. The input oil is directed to the TSRC and TSRC-S bearings at the small end (SE) of the roller via oil jets. This provides lubrication to the raceways as well as the ribs.

The parameters tabulated are the oil flow, cup temperature, rib temperature, oil out temperature and the test head torque. The test head torque is the measured torque of the total four (4) bearings in the test housing. The changes in oil flow, shown in these tables, are to the test bearing located at the oil-off position. The three other bearings were supplied with a constant oil flow, thus any torque change was caused by the change in oil flow to the oil-off position bearing.

The normal lubrication tests of the powder metal ribs in the speed range of 24,000 rpm (1.6 million DN) and up showed distress occurred on the rib face of the ribbed cup bearings. The CBS1000M 65% dense cup ribs, serial no. 84-77 and 84-78 are shown on Figure 13. The surface of these ribs began to flake away at 24,000 rpm (1.6 million DN) and 31,000 rpm (2.0 million DN) respectively. The microhardness of these ribs were measured after test as 59 HRC for cup rib 84-77 and 59.5 HRC for cup rib 84-78.

This was found in comparing the rib traces for the VIMVAR CBS600, M2 65% density, and CBS1000M 65% and 75% density, shown on Figures 14 through 16, respectively. All of these ribs were operated up to 37,000 rpm (2.4 million DN). The VIMVAR CBS600 rib wear is considered typical and not unusual for the high speed operation. The M2 65% rib indicates excessive wear compared to the VIMVAR CBS600. The calculated wear rate of 1.125×10^{-7} is in the surface fracture wear range with a trend toward surface fatigue [Ref. 7]. The post test analysis of this rib also indicates a loss of hardness occurred either during the running of the rib or the machining. As explained in the material tested section, the powder metal ribs were ground without a lubricant coolant to eliminate contamination of the powder metal material. If grinding coolant was absorbed into the open pores of the rib, the Vilella's etch would become

ineffective. A portion of the grinding coolant could be driven out; however, the remaining coolant in the rib would cause non-uniformity of the surface porosity when etching. Investigation of rib rings ground then Vilella's etched showed uniformly distributed open pores but low particle hardness ranging from 45 - 55 HRC. Hardened rib rings were selected for subsequent tests and the rib rings which measured hardness less than 58 HRC were reground to remove the soft outer layer. The reground ribs were ground with coolant to eliminate localized heat damage, ultrasonically cleaned then re-etched.

Comparing the bearing performance of the powder metal component bearing with the standard full density component bearing, it was observed that the powder metal component bearing operates at a higher temperature. Referring to Tables XVII and XIII for the TSMR CBS600 and TSMR-S CBS1000M 75% ribs, the powder metal bearing operated approximately 10°K (18°F) hotter than the CBS600 bearing at 11,000 rpm (0.72 million DN). The TSRC and TSRC-S bearings followed similar characteristic when comparing cup and rib temperatures, as shown on Tables XVIII and XVI, at 11,000 rpm (0.72 million DN). This characteristic then changes at speeds over 24,000 rpm (1.6 million DN), with the standard VIMVAR CBS600 cup and rib slightly higher than the powder metal component bearing. The differences in temperature are less than 8% for the range of speeds tested.

Task V - Minimum Lubrication/Oil-Off Test - Conventional Design

The results of the test run using the VIMVAR CBS600 cone rib (TSMR), cup rib (TSRC), and TSMA bearings are shown on the following tables:

<u>Table</u>	<u>Style</u>
XVII	TSMR
XVIII	TSRC
XIX	TSMA

The minimum lubrication for the TSRC was established when the torque and temperature became unstable at the lower flow rates.

The TSMR style was operated up through 24,000 rpm (1.5 million DN) to measure the minimum oil flow. The test run was stopped prematurely, caused by a broken oil line to the center bearings.

The minimum oil flow for the TSRC ribbed cup design was tested through 37,000 rpm (2.4 million DN) as shown on Table XVIII. The minimum oil flow established

at 37,000 rpm (2.4 million DN) was 1.9 L/min (4.0 pt/min) directed to the small end of the bearing. The temperature versus flow rate is plotted on Figure 17 illustrating the bearing response at 24,000 rpm (1.6 million DN) for the TSRC design and the TSRC-S design.

The minimum oil flow to the TSMA bearing was established up through 17,000 rpm (1.1 million DN). The extruded cage on this bearing limits the speed attainable. The minimum oil flow established with the TSMA bearing at 17,000 rpm (1.1 million DN) was 0.19 L/min (0.4 pt/min) to the large end of the roller/rib conjunction. No oil was supplied to the small end at the minimum oil flow. The TSRC-ML microporous polymer cage fill bearing performance results through 30,000 rpm (2.0 million DN) are shown in Table XX.

It has been observed that the minimum flow rates for the powder metal and the conventional design yield similar bearing performance characteristics. Based on this observation, the minimum flow rate was not tested for all bearing combinations of the conventional design and the powder metal designs.

The oil-off times for the conventional design are shown on Table XXI and Table XXII for the ribbed cone (TSMR) and ribbed cup (TSRC) designs respectively. These tables also include the oil-off times for the powder metal components which will be discussed in a later section of the report. The TSMA bearing style was oil-off tested at 4,000 rpm (0.26 million DN) only, which survived for 10.4 minutes. The oil-off time of the TSMA bearing was short compared to the other bearing styles at 4,000 rpm (0.26 million DN). No other speeds were tested.

The tables indicate that all the bearing styles except for the JEX1292CB (TSMA) survived for at least 30 minutes at 4,000 rpm (0.26 million DN). The JEX1292CC TSMR oil-off bearing life decreased rapidly with every speed level increase, as shown on Table XXI. The JEX1292CE bearing, TSRC, achieved 30 minutes oil-off at 4,000 rpm (0.26 million DN) and 11,000 rpm (0.72 million DN); however, at speeds greater than 11,000 rpm (0.72 million DN) the life dropped dramatically to seconds, as shown on Table XXII.

Task VI - Minimum Lubrication/Oil-Off Survivable Design

The results of the minimum oil flow for the TSMR-S design with the CBS1000M 75% density cone ribs are shown on Table XIII, for speeds up through 37,000 rpm (2.4 million DN). The TSMR-S bearing powder metal cone rib fractured at 37,000 rpm (2.4 million DN) with an oil flow of 1.4 L/min (3.0 pt/min) to the small end and 4.7 L/min (10.0 pt/min) to the large end. The bearing components

are shown on Figure 18. As shown on the table, the ribbed cone bearing can be operated with lubrication only at the roller large end/rib conjunction up through speeds of 24,000 rpm (1.6 million DN). At speeds greater than this, oil was required at the small end of the roller as well as the large end/rib conjunction.

The minimum flow rate at 4,000 rpm (0.26 million DN) was not measured. The minimum flow rates for the TSRC-S, ribbed cup, CBS1000M 65% and 75% density are shown in Tables XV and XVI, respectively. The oil is directed to the bearing at only the small end of the roller in this bearing style. Table XV is the oil flow result of the JEX1292CF, TSRC-S, CBS1000M 65% cup rib for speeds up through 24,000 rpm (1.6 million DN). The test run for the CBS1000M 65% was stopped at 30,000 rpm (2.0 million DN) due to a high torque caused by the powder metal rib face surface degradation. The test run for the CBS1000M 75% density was stopped because of transmission output shaft gear damage. The minimum oil for 30,000 rpm (2.0 million DN) and 37,000 rpm (2.4 million DN) is shown on Table XVIII.

The microporous polymer lubricant cage bearing performance is shown on Table XX. The test runs using the specially manufactured cage to contain the microporous polymer lubricant did not extend the oil-off times of the VIMVAR CBS600 cup rib. The development of the microporous polymer lubricant technique showed an advantage in other types of applications [Ref. 9] when using the microporous polymer lubricant; however, the microporous polymer lubricant was in direct contact with the surface requiring the film of lubricant. Neither the cage nor the microporous polymer lubricant material in the cage was in direct contact with the rib face or the bearing race to provide lubrication. The bearing could not operate effectively with this type of rubbing contact on the races or on the rib as the torque and heat generation would be excessive and intolerable.

The test was conducted with a VIMVAR CBS600 cup rib. The normal performance data is comparable to the standard machine cage as shown in Table XVIII. The radial load system became inoperable after 17,000 rpm, therefore only an axial load was applied to the test bearings at 24,000 rpm (1.6 million DN) and 30,000 rpm (2.0 million DN).

Oil-Off

The oil-off results for the powder metal ribs are shown on Tables XXI and XXII for the ribbed cone and ribbed cup designs, respectively. These tables show all the results of the oil-off test including the VIMVAR CBS600, the microporous polymer lubricant cage, and the powder metal ribs.

Referring to Table XXII, the oil-off time for the JEX1292CF, CBS1000M 65%, at 17,000 rpm shows longer oil-off time compared to the other bearing styles. This long oil-off time was due to a bleed-in of oil from another section of the test housing to the oil-off bearing cavity. The bleed-in occurred only on this run.

The higher speeds of 24,000 rpm (1.6 million DN) through 37,000 rpm (2.4 million DN) were not tested for the TSRC-S bearing style using powder metal materials, based on the performance of the ribs at the intermediate speed of 17,000 rpm (1.1 million DN). The CBS1000M powder metal ribbed cup bearings were oil-off tested at speeds of 12,000 rpm (0.78 million DN) and 13,000 rpm (0.84 million DN).

The oil-off times for the ribbed cone bearings only exceed 30 minutes at the 4,000 rpm (0.26 million DN) speed level except for the JEX1292CB (TSMA). The oil-off times at the speeds of 11,000 rpm (0.72 million DN) through 37,000 rpm (2.4 million DN) did not achieve the 30 minute goal. These oil-off times decrease rapidly with each speed increase. The oil-off times left blank are for the bearing styles not tested due to the short times of preceding test runs. The longest oil-off times of the ribbed cone bearing styles (TSMR-S) for speeds at 11,000 rpm (0.72 million DN) and beyond, were achieved with the JEX1292CD, CBS1000M 65% density cone rib bearing. Figures 19 through 22 illustrate the conventional TSMR as well as the TSMR-S survivable design M2 H.S.S. 65% density, CBS1000M 65% density, and CBS1000M 75% density bearing oil-off tested at 11,000 rpm (0.72 million DN). Figure 23 shows the CBS1000M 65% density cone rib and bearing components that survived for 5.1 minutes oil-off at 17,000 rpm (1.1 million DN).

Table XXII shows the oil-off times for the ribbed cup style bearings. The JEX1292CF, TSRC-S, CBS1000M 65% is the only bearing that did not achieve the 30 minute oil-off goal at 11,000 rpm. The reduction in oil-off performance for the speeds from 17,000 rpm (1.1 million DN) through 37,000 rpm (2.4 million DN) resulted in changing the procedure to go back to speeds of 12,000 rpm (0.78 million DN) and 13,000 rpm (0.84 million DN) to collect more data points.

Figures 24 through 26 show the survivable ribbed cup style bearings tested at 12,000 rpm (0.78 million DN). Figure 24 illustrates the M2 H.S.S. 65% density cup rib which survived for 22.1 minutes oil-off. The electro-etched CBS1000M 65% density cup rib and bearing components are shown in Figure 27. This bearing operated 15.2 minutes oil-off at 12,000 rpm (0.78 million DN).

The powder metal ribs tested at the 12,000 rpm (0.78 million DN) and 13,000 rpm (0.84 million DN) speeds were all microhardness checked to insure proper hardness. The electro-etched ribs tested at 12,000 rpm (0.78 million DN) survived 18.1 and 6.5 minutes.

The temperature and torque response for the CBS1000M 65% density ribbed cup at 11,000 rpm (0.72 million DN) is shown on Figure 28. The loss of external oil causes the torque to decrease and the cup and rib temperature to increase. The torque and temperature spike indicate a transient occurred, followed by a decrease in torque and temperature. The oil impregnated into the cup rib would have expanded and flowed to the rib surface at this time to provide a film of oil to the roller end/rib conjunction. The bearing continued to operate until the test was suspended after 30 minutes total oil-off time.

Figure 29 is a torque and temperature graph for the 12,000 rpm (0.78 million DN) oil-off run of the electro-etched CBS1000M 65% density cup rib. The bearing did not survive the 30 minute goal in this case and the bearing torque and temperature caused a premature termination.

Cup rib rings 84-55 and 84-53, damaged at 24,000 rpm (1.6 million DN) and 30,000 rpm (2.0 million DN), respectively, while operating with normal lubrication, were analyzed. Also two damaged cup ribs, 84-58 and 84-64, that were operated at 17,000 rpm (1.1 million DN) were analyzed in an attempt to determine the cause of damage.

Metallographic examinations of the failed powder metal rib rings showed a significant amount of plastic deformation resulting in a layer of completely collapsed pores at the rib face (up to 0.508 mm (0.020 in.) deep) where roller contacts had been made during test (See Figure 30). Microhardness measurements (i.e., hardness of powder particles) revealed that hardness of the powder metal rib ring was only 45-50 HRC which is significantly lower than the specified hardness of 58-60 HRC (See Table XXIII). Undoubtedly, the collapsed pores at the rib face, caused by low hardness, prevented oil supply from internal pores of the powder metal rib ring during oil-off test, and premature failure of the powder metal rib ring occurred.

This investigation proceeded to determine how and when the powder metal rib ring became softened and pores at the rib surface became collapsed. As compacted, sintered and heat treated rib rings have the hardness of 58-60 HRC as shown in Table XXIII, and shows uniformly distributed open pores at the rib face.

The rib rings, after break-in runs at the higher speed levels with normal oil supply, showed not only low particle hardness but also collapsed pores at the rib face (up to 0.0508 mm (0.002 in.) deep) where roller contacts were made (See Table XXIII and Figure 31).

The rib rings probably were softened by exceeding the tempering temperature of 811°K (1000°F) during dry grinding, and pores at the rib face collapsed during break-in runs with oil due to its lower strength. Even after pores at the rib face became collapsed, the powder metal rib rings ran satisfactorily with normal lubrication.

However, as soon as oil supply was disconnected for the oil-off test, temperatures of the rib ring apparently increased above transformation temperature (A_1) and transformed tempered martensite into austenite and further collapsing of pores took place (See Figure 30). An increase in the amount of retained austenite at rib face of the oil-off tested rib ring was confirmed by x-ray diffraction technique (See Table XXIV). Also, the presence of an oxide layer on the rib face of the oil-off tested rib ring indicates that the rib face was exposed to a high temperature (See Figure 30).

It appears that grinding of powder metal rib rings without coolant increased the temperature of the rib face above its tempering temperature and softened rib rings. The reason for dry grinding was to eliminate possible entrapment of coolant in the pores. The powder metal rib ring was not oil impregnated prior to grinding in order to minimize the detrimental effect of the oil on acid etching to remove the Bielby layer.

The theory of softening at grinding can be applied to the early powder metal ribs which had short lives; however, the bearings which were tested after this problem became obvious were able to achieve only a small increase in life and could not achieve the 30 minute goal.

Another modification to the powder metal components was to eliminate the fines (mesh size -325) as shown on Table II. This elimination of the fine will allow the rib to have a more uniform porosity at the same density level and hold more residual oil. This modification did improve the oil-off times slightly; however, the bearings still did not meet the oil-off goal at the higher speeds.

The acid etch to remove the Bielby layer was a very sensitive procedure. The porosity of the rib surface was difficult to determine other than visually. Also, the technique of the acid etch places the rib ring into a very harsh environment, allowing the acid to wick into the porosity of the powder metal rib ring. Extreme care was taken to ultrasonically remove the acid by immersing the rib ring in a neutralizer. The acid, however, does attack the particle boundaries of the powder metal material and weaken the structure. Therefore, while the microhardness measurement of a single metal particle indicates acceptable hardness, however, the structure has been weakened.

The electro-etch technique would be a method to control the removal of the Bielby layer and rib is immersed in the electrolyte for a short period. The electrolyte used with the electro-etch process is not as caustic to the powder metal rib as the Vilella's, and the rib is only exposed to the electrolyte approximately one-third of the time compared to that of the Vilella's acid etch method.

SUMMARY OF RESULTS

The lives of the powder metal rib components above 11,000 rpm (0.72 million DN) were below the 30 minute goal established for this program. The removal of the Bielby layer is perhaps the one most important event to achieve a longer oil-off time for the powder metal rib. The rib has shown in the test runs to be the vulnerable component. The new technique of removing the Bielby layer with electro-etching appears to be a controllable and repeatable method. The electro-etch was used for only two test run; however, additional tests were not within the scope of this program. The Timken Company continued investigations to refine the electro-etch method with promising results to open up the surface porosity. For example, when using the Vilella's etch, the complete component must be immersed into the acid subjecting the complete component to be etched. This etching technique could not control uniform etching across the entire face of the rib because of the geometry, size, and non-uniformity of the powder metal particles, but the electro-etch technique only etches the surface required and also the time of etching is much shorter. The Bielby layer is generated in the finish grinding of the component which is necessary to achieve the required dimensional control of the rib ring. An alternative final grinding technique that would not generate the Bielby layer was discussed during the program; however, due to the time, funding, and scope of the program, this could not be pursued. The "standard" bearing oil-off performance was 10 minutes at 4,000 rpm (0.26 million ND).

The oil-off program could be considered successful in part as extending the oil-off survivable capability of a tapered bearing by the application of a powder metal rib ring for an outer race/rib design. The thirty minute oil-off goal was achieved in this program for speeds up through 11,000 rpm (0.72 million DN) for the ribbed cup design; however, to operate up through 37,000 rpm (2.4 million DN), an auxiliary oil supply was necessary. The ribbed cup style bearing achieved a longer survivable time than the ribbed cone style.

The preparation of the powder metal rib is critical for the performance during normal operation with oil as well as at oil-off. The Vilella's etch technique to remove the Bielby layer (grinding smear) was inconsistent, intolerable to oil in the powder metal component, and weakened the inter-particle strength of the powder metal component. The elimination of the fine particles in the powder allowed for a more uniform density in the finished powder metal component.

The dry grinding of the powder metal component can cause localized overheating at the surface and reduce the hardness. The alternative to the Vilella's etch method would be an electro-etch, which allows the powder metal rib rings to be ground with a coolant thus eliminating the localized heating. The powder metal ribs can be electro-etched with the rib previously impregnated with a lubricant.

Preliminary test results, with rib cups prepared by a combination of electro-etching processes and controlling powder particle size, show encouraging results.

The microporous polymer lubrication in the cage did not achieve longer oil-off times than the standard cage design.

REFERENCES

1. A. J. Lemanski, J. W. Lenski, Jr., and R. J. Drago of The Boeing Company, Vertol Division. "Design and Fabrication, Test and Evaluation of Spiral Bevel Support Bearings (Tapered Bearings) USAAMRDL-TR-73-16, June 1973.
2. J. W. Lenski, Jr. of Boeing Vertol Company. "Test Report and Design Technology Development Report - HLH/ATC High Speed Tapered Roller Bearing Development Program", USAAMRDL-TR-74-33, June 1974.
3. R. F. Cornish, P. S. Orvos, and G. J. Dressler of The Timken Company. "Design Development and Testing of High Speed Tapered Roller Bearings for Turbine Engines", AFAPL-TR-75-26, July 1975.
4. P. S. Orvos and G. J. Dressler of The Timken Company. "Tapered Roller Bearing Development for Aircraft Turbine Engines", AFAPL-TR-79-2007, March 1979.
5. J. W. Lenski, Jr. of Boeing Vertol Company. "Advanced Transmission Components Investigation Program — Bearing and Seal Development", USAAVRADCOM-TR-80-D-19, August, 1980.
6. C. F. Jatczak, P. W. Lee, and P. S. Orvos of The Timken Company. "Tapered Roller Bearing Capable of Sustained Operation Without Lubricant Replenishment", Patent Number 4,601,592, July 22, 1986.
7. G. E. Kreider, G. J. Dressler of The Timken Company. "Preliminary Screening Study of P/M Materials for Improved Oil-Off Survivability of Tapered Roller Bearings", NASA CR 174770, October 1984.
8. E. Rabinowicz of Massachusetts Institute of Technology, "Wear", Vol. 100, pp. 533 - 541.

TABLE II - PARTICLE SIZE DISTRIBUTION

Mesh Size	Microns	CBS 1000M %	M-2 (H.S.S.) %	T-15 (H.S.S.) %
+ 60	> 250	Trace	----	----
+ 80	> 177	0.1	----	----
+100	> 149	2.5	1.0	1.0
+150	> 95	---	13.0	13.0
+200	> 74	26.9	22.0	22.0
+270	> 57	20.1	---	---
+325	> 44	11.6	30.0	30.0
-325	< 44	38.8	35.0	35.0

TABLE III. BEARING MATERIAL AND SPECIFICATIONS

BEARING PART NUMBER	TYPE	RACE	RIB	MATERIAL and CAGE PILOT	CAGE	% DENSITY	TASK
JEX1292CB-29521	TSMA	CBS600		CBS600	SAE1310		V
JEX1292CC-JEX1292D9	TSMR	CBS600		CBS600	SAE4340		V
JEX1292CD-JEX1292DB	TSMR-S	CBS600		M2 CBS1000M CBS1000M	SAE4340 SAE4340 SAE4340	65 65 75	IV VI IV VI IV VI
JEX1292CE-JEX1292D9	TSRC	CBS600		CBS600	SAE4340		V
JEX1292CF-JEX1292DB	TSRC-S	CBS600		M2 CBS1000M CBS1000M	SAE4340 SAE4340 SAE4340	65 65 75	IV VI IV VI VI VI
JEX1292CG-JEX1292DB	TSRC-HL	CBS600		CBS600	SAE4340		V

BEARING SPECIFICATIONS

BEARING GEOMETRY

CUP INCLUDED ANGLE 34-00-00 (DEG-MIN-SEC)
 CONE INCLUDED ANGLE 27-52-00 (DEG-MIN-SEC)
 ROLLER DATA
 NO. OF ROLLERS 18
 SMALL END DIAMETER 8.321 (0.3276) mm(in)
 LARGE END DIAMETER 9.286 (0.3650)
 OVERALL LENGTH 18.108 (0.7129)
 EFFECTIVE LENGTH 17.112 (0.6195)
 CROWN RADIUS 127C0.0 (50J.00)

INSPECTION

COMPONENTS - CONE CUPS AND ROLLERS (TIMKEN SPEC.)

MAGNETIC PARTICLE INSPECTION (PS 607)
 ETCH INSPECTION (PS 503)
 VISUAL INSPECTION (PS 602)
 CASE DEPTH BY HS TECHNIQUE (PS 608)
 CAGE - GLASS BEAD PEENED (CODE 470)

MATERIAL SPECIFICATIONS

VIMVAR CBS600 - AMS 6255
 CEVM 4340 - AMS 6414
 SILVER PLATED CAGES - AMS 2412

Table IV - DATA ACQUISITION-INSTRUMENTATION

<u>Data</u>	<u>Transducer</u>	<u>Conditioning</u>	<u>Measurement</u>
Test Shaft Speed	Airpax Magnetic Pickup Model: 1-0024 Accuracy: Application Dependent	Electro Mini Tach Model: 5407 Range: 0-20 KHz Accuracy: $\pm 0.5\%$ of full scale	Hewlett
Torque	Elbow Torque Table Model: 2230-101 (2000 in-lb) Repeatability: $\pm 1\%$ Non-Linearity: $\pm 0.1\%$	Daytronic Strain Gage Conditioner Model: 601B Accuracy: 0.1% of range	Packard 3497A
Load (2)	Lockheed Load Cell Model: 3500-20 (20K) Repeatability: 0.1% of full scale Non-Linearity: $\pm 0.25\%$ full scale	Daytronic Strain Gage Conditioner Model: 601B + 601A Accuracy: 0.1% of range	Data Acquisition Control Unit Accuracy:
Oil Flow (5)	Halliburton Turbine Flow Meter Model: 1/2" and 3/4" Repeatability: $\pm 0.02\%$	Halliburton Frequency Converter Model: FC-601 Output: 4-20 MA	
Temperature (16)	Iron-Constantan Thermocouples (Type J) Accuracy: $\pm 2^{\circ}\text{F}$	None	$< .5^{\circ}\text{C}$ for temperature

TABLE V. BEARINGS TESTED AND SERIAL NUMBERS																
SERIAL NUMBERS OF TESTED BEARINGS																
JEX1292CB 24521 TSMA		JEX1292CC JEX1292DB TSMA			JEX1292CD JEX1292DB TSMA-S			JEX1292CE JEX1292DB TSRC			JEX1292CF JEX1292DB TSRC-S			JEX1292CG JEX1292DB TSRC-PL		
EDGE	CUP	CONE	CUP	RIB	CONE	CUP	RIB	EDGE	CUP	RIB	CONE	CUP	RIB	EDGE	CUP	RIB
84-01	84-03	84-01	84-75	84-01	84-01	84-92	84-03	84-01	84-01	84-04	84-01	84-26	84-26	84-01	84-90	84-20
		84-02	84-103	84-03	84-02	84-15	84-47	84-02	84-03	84-31	84-07	84-02	84-07	84-02	84-93	84-27
		84-03	84-104	84-04	84-03	84-22	84-23	84-03	84-05	84-03	84-02	84-03	84-125	84-03	84-92	84-25
		84-04	84-105	84-05	84-04	84-27	84-01	84-04	84-06	84-04	84-01	84-04	84-11	84-04	84-92	84-25
		84-05	84-107	84-06	84-05	84-40	84-02	84-05	84-07	84-02	84-05	84-05	84-06	84-05		
		84-06	84-108	84-07	84-06	84-44	84-05	84-06	84-07	84-03	84-07	84-07	84-33	84-07		
		84-07	84-109	84-08	84-07	84-66	84-46	84-08	84-08	84-08	84-08	84-08	84-05	84-08		
		84-08	84-112	84-09	84-08	84-55	84-01	84-09	84-09	84-09	84-09	84-10	84-08	84-09		
		84-09	84-113	84-10	84-09	84-59	84-14	84-10	84-10	84-10	84-10	84-11	84-10	84-10		
		84-10	84-114	84-11	84-10	84-67	84-02	84-11	84-11	84-11	84-11	84-12	84-10	84-11		
		84-11	84-115	84-12	84-11	84-37	84-19	84-12	84-12	84-12	84-12	84-13	84-11	84-12		
		84-12	84-116	84-13	84-12	84-58	84-20	84-13	84-13	84-13	84-13	84-14	84-11	84-13		
		84-13	84-117	84-14	84-13	84-68	84-20	84-14	84-14	84-14	84-14	84-15	84-11	84-14		
		84-14	84-118	84-15	84-14	84-38	84-49	84-15	84-15	84-15	84-15	84-16	84-11	84-15		
		84-15	84-119	84-16	84-15	84-65	84-20	84-16	84-16	84-16	84-16	84-17	84-11	84-16		
		84-16	84-120	84-17	84-16	84-65	84-20	84-17	84-17	84-17	84-17	84-18	84-11	84-17		
		84-17	84-121	84-18	84-17	84-67	84-28	84-18	84-18	84-18	84-18	84-19	84-11	84-18		
		84-18	84-122	84-19	84-18	84-70	84-29	84-19	84-19	84-19	84-19	84-20	84-11	84-19		
		84-19	84-123	84-20	84-19	84-73	84-30	84-20	84-20	84-20	84-20	84-21	84-11	84-20		
		84-20	84-124	84-21	84-20	84-74	84-31	84-21	84-21	84-21	84-21	84-22	84-11	84-21		
		84-21	84-125	84-22	84-21	84-77	84-09	84-22	84-22	84-22	84-22	84-23	84-11	84-22		
		84-22	84-126	84-23	84-22	84-78	84-14	84-23	84-23	84-23	84-23	84-24	84-11	84-23		
		84-23	84-127	84-24	84-23	84-81	84-14	84-24	84-24	84-24	84-24	84-25	84-11	84-24		
		84-24	84-128	84-25	84-24	84-82	84-07	84-25	84-25	84-25	84-25	84-26	84-11	84-25		
		84-25	84-129	84-26	84-25	84-83	84-08	84-26	84-26	84-26	84-26	84-27	84-11	84-26		
		84-26	84-130	84-27	84-26	84-85	84-08	84-27	84-27	84-27	84-27	84-28	84-11	84-27		
		84-27	84-131	84-28	84-27			84-28	84-28	84-28	84-28	84-29	84-11	84-28		
		84-28	84-132	84-29	84-28			84-29	84-29	84-29	84-29	84-30	84-11	84-29		
		84-29	84-133	84-30	84-29			84-30	84-30	84-30	84-30	84-31	84-11	84-30		
		84-30	84-134	84-31	84-30			84-31	84-31	84-31	84-31	84-32	84-11	84-31		
		84-31	84-135	84-32	84-31			84-32	84-32	84-32	84-32	84-33	84-11	84-32		
		84-32	84-136	84-33	84-32			84-33	84-33	84-33	84-33	84-34	84-11	84-33		
		84-33	84-137	84-34	84-33			84-34	84-34	84-34	84-34	84-35	84-11	84-34		
		84-34	84-138	84-35	84-34			84-35	84-35	84-35	84-35	84-36	84-11	84-35		
		84-35	84-139	84-36	84-35			84-36	84-36	84-36	84-36	84-37	84-11	84-36		
		84-36	84-140	84-37	84-36			84-37	84-37	84-37	84-37	84-38	84-11	84-37		
		84-37	84-141	84-38	84-37			84-38	84-38	84-38	84-38	84-39	84-11	84-38		
		84-38	84-142	84-39	84-38			84-39	84-39	84-39	84-39	84-40	84-11	84-39		
		84-39	84-143	84-40	84-39			84-40	84-40	84-40	84-40	84-41	84-11	84-40		
		84-40	84-144	84-41	84-40			84-41	84-41	84-41	84-41	84-42	84-11	84-41		
		84-41	84-145	84-42	84-41			84-42	84-42	84-42	84-42	84-43	84-11	84-42		
		84-42	84-146	84-43	84-42			84-43	84-43	84-43	84-43	84-44	84-11	84-43		
		84-43	84-147	84-44	84-43			84-44	84-44	84-44	84-44	84-45	84-11	84-44		
		84-44	84-148	84-45	84-44			84-45	84-45	84-45	84-45	84-46	84-11	84-45		
		84-45	84-149	84-46	84-45			84-46	84-46	84-46	84-46	84-47	84-11	84-46		
		84-46	84-150	84-47	84-46			84-47	84-47	84-47	84-47	84-48	84-11	84-47		
		84-47	84-151	84-48	84-47			84-48	84-48	84-48	84-48	84-49	84-11	84-48		
		84-48	84-152	84-49	84-48			84-49	84-49	84-49	84-49	84-50	84-11	84-49		
		84-49	84-153	84-50	84-49			84-50	84-50	84-50	84-50	84-51	84-11	84-50		
		84-50	84-154	84-51	84-50			84-51	84-51	84-51	84-51	84-52	84-11	84-51		
		84-51	84-155	84-52	84-51			84-52	84-52	84-52	84-52	84-53	84-11	84-52		
		84-52	84-156	84-53	84-52			84-53	84-53	84-53	84-53	84-54	84-11	84-53		
		84-53	84-157	84-54	84-53			84-54	84-54	84-54	84-54	84-55	84-11	84-54		
		84-54	84-158	84-55	84-54			84-55	84-55	84-55	84-55	84-56	84-11	84-55		
		84-55	84-159	84-56	84-55			84-56	84-56	84-56	84-56	84-57	84-11	84-56		
		84-56	84-160	84-57	84-56			84-57	84-57	84-57	84-57	84-58	84-11	84-57		
		84-57	84-161	84-58	84-57			84-58	84-58	84-58	84-58	84-59	84-11	84-58		
		84-58	84-162	84-59	84-58			84-59	84-59	84-59	84-59	84-60	84-11	84-59		
		84-59	84-163	84-60	84-59			84-60	84-60	84-60	84-60	84-61	84-11	84-60		
		84-60	84-164	84-61	84-60			84-61	84-61	84-61	84-61	84-62	84-11	84-61		
		84-61	84-165	84-62	84-61			84-62	84-62	84-62	84-62	84-63	84-11	84-62		
		84-62	84-166	84-63	84-62			84-63	84-63	84-63	84-63	84-64	84-11	84-63		
		84-63	84-167	84-64	84-63			84-64	84-64	84-64	84-64	84-65	84-11	84-64		
		84-64	84-168	84-65	84-64			84-65	84-65	84-65	84-65	84-66	84-11	84-65		
		84-65	84-169	84-66	84-65			84-66	84-66	84-66	84-66	84-67	84-11	84-66		
		84-66	84-170	84-67	84-66			84-67	84-67	84-67	84-67	84-68	84-11	84-67		
		84-67	84-171	84-68	84-67			84-68	84-68	84-68	84-68	84-69	84-11	84-68		
		84-68	84-172	84-69	84-68			84-69	84-69	84-69	84-69	84-70	84-11	84-69		
		84-69	84-173	84-70	84-69			84-70	84-70	84-70	84-70	84-71	84-11	84-70		
		84-70	84-174	84-71	84-70			84-71	84-71	84-71	84-71	84-72	84-11	84-71		
		84-71	84-175	84-72	84-71			84-72	84-72	84-72	84-72	84-73	84-11	84-72		
		84-72	84-176	84-73	84-72			84-73	84-73	84-73	84-73	84-74	84-11	84-73		
		84-73	84-177	84-74	84-73			84-74	84-74	84-74	84-74	84-75	84-11	84-74		

TABLE VII. BEARING STRESS SURVEY SI UNITS

BEARING	DN MILLION	STRESS (MPa)		
		CONE/ROLLER	CUP/ROLLER	RIB/ROLLER
HM617000	0.503	888.08	810.16	173.06
L217800	0.522	496.44	480.58	59.99
LL639200	0.242	595.73	567.46	62.060
L610500	0.267	806.72	750.86	103.46
29500	0.194	762.59	695.02	136.52
L507900	0.230	876.35	810.16	66.88
665	0.366	1500.35	1326.60	140.66
465	0.133	719.15	626.07	75.84
L116100	0.128	988.74	919.10	51.02
5700	0.328	930.82	834.98	106.18
64000	0.033	1110.10	1006.67	148.93
M716600	0.137	1208.69	1099.75	102.74
L244500	0.067	992.19	959.78	40.68
L814700	0.461	747.42	710.87	63.43
74000	0.446	956.34	879.80	128.25
87000	0.050	1253.51	1150.78	79.98
28500	0.108	845.33	749.49	111.01
L225800	0.170	786.72	743.97	37.23
37000	0.165	980.47	912.90	111.01
6500	1.930	1042.52	1030.11	253.05
6500	0.483	513.68	464.72	133.07
XC1933	3.500	344.75	806.02	151.00
JXC25427	1.330	540.57	627.44	203.40
JXC25427	1.330	1330.74	1259.03	259.94
XC11439	1.610	1040.46	1043.21	206.16
XC11440	1.610	697.08	766.03	144.11
SUM	16.343	22955.52	22031.59	3149.64
MEAN	0.629	882.30	347.37	121.14
STDEV	0.805	272.27	220.41	61.03

TABLE VIII. BEARING STRESS SURVEY ENGLISH UNITS

BEARING	DN MILLION	STRESS (KSI)		
		CONE/ROLLER	CUP/ROLLER	RIB/ROLLER
HM617000	0.503	128.8	117.5	25.1
L217800	0.522	72.0	69.7	8.7
LL639200	0.242	86.4	82.3	9.0
L610500	0.267	117.0	108.9	15.0
29500	0.194	110.6	100.8	19.8
L507900	0.230	127.1	117.5	9.7
665	0.366	217.6	192.4	20.4
465	0.133	104.3	90.8	11.0
L116100	0.128	143.4	133.3	7.4
5700	0.328	135.0	121.1	15.4
64000	0.033	161.0	146.0	21.6
M716600	0.137	175.3	159.5	14.9
L244500	0.067	143.9	139.2	5.9
L814700	0.461	108.4	103.1	9.2
74000	0.446	138.7	127.6	18.6
87000	0.050	181.8	166.9	11.6
28500	0.108	122.6	108.7	16.1
L225800	0.170	114.1	107.9	5.4
37000	0.165	142.2	132.4	16.1
6500	1.930	151.2	149.4	36.7
6500	0.483	74.5	67.4	19.3
XC1933	3.500	50.0	116.9	21.9
JXC25427	1.330	78.4	91.0	29.5
JXC25427	1.330	193.0	182.6	37.7
XC11439	1.610	150.9	151.3	29.9
XC11440	1.610	101.1	111.1	20.9
COL SUM	16.343	3329.3	3195.3	456.8
COL MEAN	0.629	128.0	122.9	17.6
COL STDEV	0.805	39.5	32.0	8.9

TABLE X - MATERIAL SCREENING TEST RESULTS

		OIL-OFF TIME (MINUTES)																					
Material Percent Density Air Purge, MPa(ps1)	Run No.	CBS 1000H 65		CBS 1000H 69 (10)		CBS 1000H 74		CBS 1000H 85		M-2 HSS 75		M-2 HSS 85		PSZ-HB 98		PSZ-HB 98		T-15 HSS 65		T-15 HSS 75		T-15 HSS 85	
		620 (90)	69 (10)	69 (10)	69 (10)	69 (10)	69 (10)	620 (90)	620 (90)	620 (90)	620 (90)	620 (90)	620 (90)	620 (90)	620 (90)	620 (90)	620 (90)	620 (90)	620 (90)	620 (90)	620 (90)	620 (90)	620 (90)
	1	10.4	240.0	236.2	225.6	9.8	11.4	3.3	9.3	7.0	2.1	4.2	3.0										
	2	10.4	240.0	155.3	168.7	10.8	12.6	6.8	4.7	4.5	12.6	12.4	2.1										
	3	22.7	240.0	153.9	156.5	22.7	12.3	9.1	3.5	1.3	9.3	4.1	3.7										
	4	8.7	-----	150.1	105.9	23.3	15.6	3.7	-----	-----	-----	-----	-----										
	5	17.3	-----	85.9	10.7	30.0	14.0	14.2	-----	-----	-----	-----	-----										
	6	16.2	-----	84.0	5.7	13.9	9.7	6.1	-----	-----	-----	-----	-----										
	7	37.9	-----	76.4	-----	54.9	59.2	5.0	-----	-----	-----	-----	-----										
	8	8.5	-----	-----	-----	139.0	10.7	3.2	-----	-----	-----	-----	-----										
	9	42.1	-----	-----	-----	30.0	13.8	-----	-----	-----	-----	-----	-----										
	Col Sum	174.1	720.0	941.6	673.1	336.3	159.3	51.3	17.5	12.8	24.0	20.6	8.7										
	Col Mean	19.3	240.0	134.5	112.2	37.4	17.7	6.4	5.8	4.3	8.0	6.9	2.9										
	Col Stdev	12.6	0.0	57.3	89.1	40.5	15.7	3.7	3.1	2.9	5.4	4.8	0.8										
	Col N	9.0	3.0	7.0	6.0	9.0	9.0	8.0	3.0	3.0	3.0	3.0	3.0										

OIL-OFF TIME (MINUTES)

Material Percent Density Air Purge, MPa(ps1)	Run No.	M-2/C 65		M-2/C (Borate)C 65		M-2/M 75		M-2/M (Borate)C 75		M-2 (Ion Nit.) ^d 75	
		69 (10)	69 (10)	69 (10)	69 (10)	69 (10)	69 (10)	69 (10)	69 (10)	69 (10)	69 (10)
	1	272.4	41.4	41.4	32.3	111.5	64.3				
	2	116.1	7.4	7.4	66.8	129.2	96.0				
	3	157.7	178.2	178.2	54.2	156.4	45.0				
	4	-----	-----	-----	-----	-----	54.3				
	Col Sum	496.2	227.1	227.1	153.3	397.1	259.6				
	Col Mean	165.4	75.7	75.7	51.1	132.4	64.9				
	Col Stdev	53.6	90.4	90.4	17.5	22.6	22.2				
	Col N	3.0	3.0	3.0	3.0	3.0	4.0				

a - PSZ-H (Maxim. Strength and Wear Resistant)
 b - PSZ-T (Maxim. Thermal Shock Resistant)
 c - Borate - EP Oil Additive Impregnated into Block
 d - Block Ion Nit. Ited

TABLE XI. PERFORMANCE DATA OF RIBBED CONE
TSMR-S M2 H.S.S. 65% DENSITY

SPEED RPM/Million DN	OIL FLOW L/min (pt/min)		TEMPERATURE K (F)		TEST HEAD TORQUE N.m (lbf-in)
	S.E.	L.E.	CUP	OIL OUT	
4000/0.26	1.2 (2.5)	4.0 (8.5)	358 (184)	357 (183)	4.5 (40)
8000/0.52	1.2 (2.5)	4.0 (8.5)	361 (190)	360 (188)	6.3 (56)
11000/0.72	1.4 (3.0)	4.3 (9.0)	364 (195)	364 (195)	7.5 (66)
17000/1.1	1.4 (3.0)	4.3 (9.0)	373 (212)	362 (210)	9.0 (80)
24000/1.6	1.9 (4.0)	4.7 (10.0)	381 (227)	381 (226)	10.9 (97)
30000/2.0	1.9 (4.0)	4.7 (10.0)	403 (265)	383 (229)	11.2 (100)
37000/2.4	2.1 (4.5)	4.7 (10.0)	411 (281)	411 (281)	13.1 (116)

TABLE XII PERFORMANCE DATA OF RIBBED CONE
TSMR-S CBS10COM 65% DENSITY

SPEED RPM/Million DN	OIL FLOW L/min (pt/min)		TEMPERATURE K (F)		TEST HEAD TORQUE N.m (lbf-in)
	S.E.	L.E.	CUP	OIL OUT	
4000/0.26	0.9 (2.0)	1.9 (4.0)	358 (185)	357 (183)	4.5 (40)
11000/0.72	0.9 (2.0)	2.8 (6.0)	375 (216)	370 (207)	7.2 (64)
	0.7 (2.0)	1.9 (4.0)	360 (205)	375 (216)	6.8 (60)
17000/1.1	1.9 (4.0)	3.8 (8.0)	390 (243)	379 (222)	9.7 (86)
	1.9 (4.0)	2.8 (6.0)	393 (247)	383 (229)	9.1 (81)
24000/1.6	1.9 (4.0)	4.7 (10.0)	401 (263)	388 (239)	10.6 (94)
30000/2.0	1.9 (4.0)	6.1 (13.0)	415 (298)	401 (262)	12.6 (112)

TABLE XIII. PERFORMANCE DATA OF RIBBED CONE
TSMR-S CBSICDOM 75% DENSITY

SPEED RPM/Million DN	OIL FLOW L/min (pt/min) S.E. L.E.		TEMPERATURE K (F)		TEST HEAD TORQUE N.m (lbf-in)
	Small End	Large End	CUP	OIL OUT	
4000/0.26	0.9 (2.0)	3.7 (8.0)	357 (183)	355 (182)	2.9 (26.0)
	0.9 (2.0)	1.9 (4.0)	359 (187)	355 (180)	4.4 (39.0)
11000/0.72	0.9 (2.0)	2.8 (6.0)	370 (208)	---	6.2 (54.5)
	0.9 (2.0)	1.9 (4.0)	375 (215)	---	6.3 (55.6)
	0.5 (1.0)	1.4 (3.0)	377 (219)	370 (207)	6.0 (53.0)
	0.2 (0.5)	0.7 (1.5)	379 (223)	371 (208)	6.0 (53.0)
	0.1 (0.2)	0.5 (1.0)	382 (228)	371 (209)	6.0 (53.0)
	0.0 (0.0)	0.2 (0.5)	389 (240)	371 (209)	6.0 (53.0)
	0.0 (0.0)	0.1 (0.2)	293 (247)	372 (210)	5.9 (52.0)
	0.0 (0.0)	0.0 (0.0)			
17000/1.1	1.9 (4.0)	3.7 (8.0)	385 (234)	381 (226)	9.0 (80.0)
	0.9 (2.0)	1.9 (4.0)	395 (252)	384 (231)	8.9 (79.0)
	0.5 (1.0)	0.9 (2.0)	407 (273)	385 (233)	8.6 (76.0)
	0.2 (0.5)	0.5 (1.0)	416 (290)	386 (235)	8.5 (75.0)
	0.0 (0.0)	0.2 (0.5)	438 (326)	385 (234)	8.2 (73.0)
24000/1.6	1.9 (4.0)	4.7 (10.0)	404 (269)	390 (243)	11.2 (99.0)
	0.9 (2.0)	3.3 (7.7)	420 (297)	394 (250)	10.8 (96.0)
	0.7 (1.5)	2.4 (5.0)	424 (304)	396 (254)	10.5 (93.0)
	0.5 (1.0)	1.9 (4.0)	426 (308)	395 (252)	10.5 (93.0)
	0.2 (0.5)	1.4 (3.0)	436 (325)	395 (252)	10.3 (91.0)
	0.0 (0.0)	1.2 (2.5)	440 (332)	396 (253)	10.3 (91.0)
	0.0 (0.0)	0.9 (2.0)	445 (341)	396 (254)	10.2 (90.0)
	0.0 (0.0)	0.0 (0.0)			
30000/2.2	1.9 (4.0)	5.2 (11.0)	415 (287)	404 (267)	12.4 (110.0)
	1.4 (3.0)	4.7 (10.0)	419 (295)	405 (270)	12.0 (106.0)
	0.9 (2.0)	4.3 (9.0)	423 (302)	405 (270)	11.9 (105.0)
	0.5 (1.0)	3.7 (8.0)	429 (312)	405 (270)	11.5 (103.0)
	0.2 (0.5)	3.3 (7.0)	429 (313)	405 (270)	11.5 (102.0)
	0.0 (0.0)	2.8 (6.0)	433 (320)	405 (271)	11.4 (101.0)
	0.0 (0.0)	2.4 (5.0)	436 (326)	405 (270)	11.4 (101.0)
	0.2 (0.5)	1.9 (4.0)	441 (334)	406 (271)	11.2 (99.0)
	0.2 (0.5)	1.7 (3.5)	448 (346)	405 (269)	11.0 (97.0)
	0.0 (0.0)	0.0 (0.0)			
37000/2.4	1.9 (4.0)	5.2 (11.0)	436 (325)	425 (305)	13.4 (119.0)
	1.4 (3.0)	4.7 (10.0)	443 (337)	425 (306)	13.2 (117.0)*

* Cone rib fractured

TABLE XIV. PERFORMANCE DATA OF RIBBED CUP
TSRC-S 42 H.30000 80% DENSITY

SPEED RPM/Million DN	OIL FLOW L/min (pt/min) S.E.	TEMPERATURE K (F)		OIL OUT	TEST HEAD TORQUE N.m (lbf-in)	COMMENTS
		CUP	Rib			
11000/0.72	2.8 (6.0)	375 (216)	378 (220)	---	6.8 (60)	
	3.1 (6.5)	375 (215)	379 (222)	369 (205)	7.6 (67)	
12000/0.78	2.8 (6.0)	383 (230)	388 (238)	374 (214)	7.5 (66)	
	2.8 (6.0)	386 (236)	391 (245)	---	7.2 (64)	
17000/1.1	3.8 (8.0)	391 (244)	396 (254)	381 (226)	8.9 (79)	
24000/1.6	6.6 (14.0)	425 (305)	439 (330)	410 (278)	6.8 (60)	5340N (1200lbf) Thrust
30000/2.0	7.6 (16.0)	441 (334)	456 (361)	419 (295)	7.1 (63)	7120N (1600lbf) Thrust
38000/2.3	7.6 (16.0)	469 (385)	489 (420)	419 (295)	7.3 (65)	7120N (1600lbf) Thrust

TABLE XV. PERFORMANCE DATA OF RIBBED CUP
TSRC-S CBS100GM 65% DENSITY

SPEED RPM/Million DN	OIL FLOW L/min (pt/min) S.E.	TEMPERATURE K (F)				TEST HEAD TORQUE N.m (lbf-in)
		CUP	RIB	OIL OUT		
4000/0.26	3.8 (8.0)	357 (183)	358 (184)	357 (183)	4.4 (39)	
	3.3 (7.0)	357 (183)	358 (184)	358 (184)	4.4 (39)	
	2.8 (6.0)	357 (183)	356 (185)	357 (183)	4.4 (39)	
	2.4 (5.0)	357 (183)	356 (185)	357 (183)	4.4 (39)	
	1.9 (4.0)	356 (181)	359 (186)	357 (183)	4.3 (38)	
	1.4 (3.0)	355 (180)	350 (189)	357 (183)	4.2 (37)	
	0.9 (2.0)	354 (177)	361 (191)	358 (184)	4.2 (37)	
	8000/0.52	3.8 (8.0)	365 (198)	365 (197)	362 (192)	6.6 (58)
2.8 (6.0)		365 (197)	356 (200)	363 (194)	6.3 (56)	
1.9 (4.0)		362 (192)	370 (206)	365 (197)	6.2 (55)	
1.4 (3.0)		361 (190)	371 (209)	366 (200)	6.2 (55)	
0.4 (2.0)		360 (189)	373 (211)	366 (202)	6.2 (55)	
0.5 (1.0)		359 (186)	373 (212)	366 (202)	6.1 (54)	
11000/0.72		4.7 (10.0)	376 (218)	370 (207)	366 (199)	7.7 (68)
		4.3 (9.0)	376 (218)	371 (209)	366 (200)	7.7 (68)
	3.8 (8.0)	376 (218)	372 (210)	366 (200)	7.7 (68)	
	3.3 (7.0)	376 (218)	374 (214)	368 (203)	7.7 (68)	
	2.9 (6.0)	374 (214)	377 (215)	369 (205)	7.7 (68)	
	2.4 (5.0)	373 (212)	379 (223)	371 (208)	7.7 (68)	
	1.9 (4.0)	371 (203)	393 (229)	372 (210)	6.8 (60)	
	1.4 (3.0)	369 (204)	384 (231)	373 (212)	6.8 (60)	
	0.9 (2.0)	367 (201)	385 (233)	373 (211)	6.8 (60)	
	0.5 (1.0)	354 (196)	389 (240)	375 (215)	6.8 (60)	
17000/1.1	4.7 (10.0)	385 (233)	399 (258)	392 (246)	10.5 (93)	
	3.8 (8.0)	372 (210)	407 (273)	403 (265)	10.4 (92)	
	2.8 (6.0)	362 (192)	419 (295)	419 (295)	9.9 (88)	
	2.4 (5.0)	365 (197)	413 (283)	386 (235)	9.8 (87)	
	1.9 (4.0)	358 (184)	420 (290)	386 (236)	9.8 (87)	
	1.4 (3.0)	350 (170)	428 (311)	389 (238)	9.7 (86)	
	0.9 (2.0)	341 (154)	436 (326)	388 (238)	9.7 (86)	
	0.5 (1.0)	331 (136)	448 (345)	385 (234)	9.4 (83)	
24000/1.6	4.7 (10.0)	386 (235)	421 (299)	394 (250)	12.0 (106)	
	3.8 (8.0)	379 (223)	429 (312)	396 (254)	12.2 (108)	
	2.8 (6.0)	371 (209)	438 (328)	398 (256)	12.0 (106)	
	2.4 (5.0)	366 (199)	443 (337)	397 (255)	11.6 (103)	
	1.9 (4.0)	356 (182)	396 (253)	398 (256)	11.6 (103)	
	1.4 (3.0)	346 (154)	457 (363)	396 (254)	11.4 (101)	
	0.9 (2.0)	336 (148)	463 (374)	391 (245)	11.2 (99)	
	30000/2.0	6.6 (14.0)	414 (285)	438 (329)	408 (275)	15.8 (140)*

* Stopped, high torque

TABLE XVI. PERFORMANCE DATA OF RIBBED CUP TSRC-S CBS1000M 75% DENSITY							
SPEED RPM/Million DN	OIL FLOW L/min (pt/min) S.E.		TEMPERATURE K (F)		OIL OUT	TEST HEAD TORQUE N.m (lbf-in)	
	Small End		CUP	Rib			
4000/0.26	3.8 (8.0)		358 (185)	359 (186)	358 (185)	4.5 (40)	
	1.9 (4.0)		366 (200)	369 (205)	372 (210)	5.4 (48)	
11000/0.72	2.8 (6.0)		378 (220)	382 (228)	371 (208)	7.3 (65)	
17000/1.1	4.7 (10.0)		386 (236)	391 (244)	380 (224)	10.4 (92)	
	3.8 (8.0)		400 (240)	411 (260)	383 (229)	10.4 (92)	
	4.3 (9.0)		395 (231)	403 (265)	383 (229)	10.1 (89)	
	3.9 (8.0)		390 (243)	397 (255)	379 (222)	9.7 (86)	
	3.8 (8.0)		398 (257)	405 (270)	385 (233)	9.6 (85)	
	3.8 (8.0)		465 (414)	515 (463)	388 (239)	9.1 (81)	
24000/1.6	5.7 (12.0)		398 (257)	406 (272)	386 (236)	14.1 (125)	
	4.7 (10.0)		404 (267)	413 (284)	388 (239)	13.9 (123)	
	3.8 (8.0)		410 (278)	420 (296)	390 (242)	13.6 (120)	
	2.8 (6.0)		419 (294)	430 (314)	390 (243)	13.0 (115)	
	2.8 (6.0)		420 (296)	432 (318)	405 (270)	11.0 (97)	
	2.4 (5.0)		425 (306)	435 (329)	409 (277)	11.1 (96)	
	1.9 (4.0)		434 (322)	449 (348)	411 (280)	11.2 (99)	
	1.4 (3.0)		444 (340)	461 (370)	413 (283)	11.2 (99)	
	.9 (2.0)		452 (354)	470 (386)	406 (272)	10.7 (95)	
	30000/2.0	5.7 (12.0)		421 (299)	433 (319)	409 (276)	15.2 (135)
		4.7 (10.0)		427 (309)	441 (334)	412 (282)	15.0 (133)
3.9 (8.0)			434 (322)	452 (354)	415 (292)	14.3 (127)	
3.3 (7.0)			436 (325)	454 (357)	416 (290)	14.1 (125)	
2.8 (6.0)			436 (326)	455 (359)	414 (286)	13.9 (123)*	

* Stopped, rig gear failure

TABLE XVII. PERFORMANCE DATA OF RIBBED CONE TSMR VIMVAR CBS600						
SPEED RPM/Million DN	OIL FLOW L/min (pt/min) S.E.		TEMPERATURE K (F)		TEST HEAD TORQUE N.m (lbf-in)	
	Small End	Large End	CUP	OIL OUT		
4000/0.26	0.9 (2.0)	3.8 (8.0)	357 (183)	357 (183)	4.2 (37)	
	0.9 (2.0)	2.8 (6.0)	356 (182)	356 (182)	3.8 (34)	
	0.9 (2.0)	1.9 (4.0)	357 (183)	356 (182)	3.7 (33)	
	0.5 (1.0)	1.4 (3.0)	357 (183)	356 (191)	3.7 (33)	
	0.5 (1.0)	1.2 (2.5)	358 (184)	357 (183)	3.7 (33)	
11000/0.72	0.9 (2.0)	3.8 (8.0)	363 (194)	365 (193)	6.6 (58)	
	0.9 (2.0)	2.8 (6.0)	365 (197)	365 (197)	6.4 (57)	
	0.9 (2.0)	1.9 (4.0)	365 (199)	365 (193)	6.2 (56)	
	0.5 (1.0)	1.4 (3.0)	367 (201)	362 (192)	6.2 (55)	
17000/1.1	1.9 (4.0)	4.7 (10.0)	372 (210)	375 (216)	8.5 (75)	
	1.9 (4.0)	3.9 (8.0)	375 (216)	374 (213)	8.2 (72)	
	1.9 (4.0)	2.8 (6.0)	376 (218)	374 (214)	7.8 (69)	
	0.9 (2.0)	2.4 (5.0)	380 (225)	374 (214)	7.6 (67)	
	0.9 (2.0)	2.4 (5.0)	383 (229)	373 (212)	7.3 (65)	
	0.5 (1.0)	2.4 (5.0)				
24000/1.6	1.9 (4.0)	5.7 (12.0)	376 (218)	388 (239)	11.1 (98)	
	1.9 (4.0)	4.7 (10.0)	375 (220)	390 (242)	10.7 (95)	
	1.9 (4.0)	3.8 (8.0)	378 (221)	383 (230)	10.2 (90)	

TABLE XVIII. PERFORMANCE DATA OF RIBBED CUP
TSRC VIMVAR CBS600

SPEED RPM/Million DN	OIL FLOW L/min (pt/min) S.E. SMALL END	TEMPERATURE K (F)			TEST HEAD TORQUE N.M (LBF-IN)
		CUP	RIB	OIL OUT	
4000/0.26	3.8 (8.0)	354 (178)	358 (185)	358 (184)	5.1 (45)
	2.8 (6.0)	354 (178)	359 (186)	358 (184)	5.0 (44)
	1.9 (4.0)	353 (176)	360 (189)	359 (187)	4.9 (43)
	0.9 (2.0)	350 (170)	364 (195)	359 (186)	4.5 (40)
11000/0.72	4.7 (10.0)	372 (210)	374 (213)	370 (206)	8.0 (71)
	3.8 (8.0)	370 (207)	376 (218)	373 (212)	7.7 (68)
	2.8 (6.0)	366 (200)	380 (224)	373 (211)	7.6 (67)
	1.9 (4.0)	361 (191)	386 (236)	381 (227)	7.3 (65)
17000/1.1	4.7 (10.0)	375 (215)	392 (246)	384 (231)	10.6 (94)
	3.8 (8.0)	370 (206)	298 (257)	388 (239)	10.3 (91)
	2.8 (6.0)	363 (195)	407 (273)	395 (251)	9.9 (88)
	2.4 (5.0)	359 (187)	413 (283)	400 (260)	9.6 (85)
	1.9 (4.0)	355 (179)	419 (294)	406 (272)	9.5 (84)
	1.7 (3.5)	349 (168)	425 (305)	411 (280)	9.3 (82)
24000/1.6	4.3 (9.0)	414 (285)	423 (302)	390 (242)	10.6 (94)
	2.8 (6.0)	427 (309)	438 (328)	392 (246)	10.2 (90)
	2.4 (5.0)	434 (321)	444 (340)	393 (247)	10.2 (90)
	1.9 (4.0)	441 (334)	431 (332)	393 (247)	9.9 (88)
	1.4 (3.0)	450 (330)	459 (366)	392 (246)	9.6 (85)
	1.2 (2.5)	450 (330)	456 (362)	391 (244)	9.5 (84)
	0.9 (2.0)	454 (337)	459 (366)	390 (243)	9.4 (83)
30000/2.0	4.7 (10.0)	435 (324)	449 (348)	405 (269)	12.9 (114)
	3.8 (8.0)	444 (339)	458 (364)	406 (272)	12.5 (111)
	2.8 (6.0)	455 (360)	470 (387)	407 (273)	12.3 (109)
	1.9 (4.0)	473 (392)	488 (418)	406 (272)	11.8 (105)
	1.4 (3.0)	479 (402)	488 (419)	404 (268)	11.6 (103)
	1.2 (2.5)	477 (399)	481 (406)	402 (264)	11.5 (102)
37000/2.4	3.3 (07.0)	480 (404)	498 (438)	435 (324)	15.5 (137)
	3.1 (06.5)	483 (410)	503 (446)	439 (330)	15.4 (136)
	2.8 (06.0)	487 (417)	507 (453)	439 (331)	15.6 (138)
	2.6 (05.5)	492 (426)	512 (462)	439 (330)	15.4 (136)
	2.4 (05.0)	496 (434)	516 (470)	438 (329)	15.5 (137)
	2.1 (04.5)	503 (443)	522 (480)	438 (329)	15.5 (135)
	1.9 (04.0)	511 (461)	530 (495)	438 (329)	15.5 (135)

TABLE XIX. PERFORMANCE DATA OF RIBBED CONE
TSMA VIMVAK C95600

SPEED RPM/Million DN	OIL FLOW L/min (pt/min)		TEMPERATURE K (F)		TEST HEAD TORQUE N.m (lbf-in)	
	S.E.	L.E.	CUP	OIL OUT		
4000/0.26	0.5 (1.0)	1.4 (3.0)	352 (193)	351 (173)	3.4 (30)	
	0.9 (2.0)	0 (0)	364 (196)	353 (175)	3.4 (30)	
	0.7 (1.5)	0 (0)	364 (196)	351 (173)	3.4 (30)	
	0.5 (1.0)	0 (0)	365 (197)	352 (174)	3.4 (30)	
	0.2 (0.5)	0 (0)	365 (197)	351 (173)	3.5 (31)	
	0.1 (0.2)	0 (0)	365 (198)	351 (173)	3.5 (31)	
11000/0.72	0.9 (2.0)	2.8 (6.0)	376 (218)	366 (200)	6.7 (59)	
	0.5 (1.0)	1.4 (3.0)	384 (231)	368 (202)	6.4 (57)	
	0.5 (1.0)	0.9 (2.0)	383 (230)	373 (212)	6.9 (61)	
	0.2 (0.5)	0.7 (1.5)	385 (234)	370 (206)	6.3 (56)	
	0.1 (0.2)	0.5 (1.0)	387 (237)	371 (209)	6.4 (57)	
	0 (0)	0.2 (0.4)	389 (240)	373 (211)	6.3 (56)	
17000/1.1	0 (0)	0.1 (0.2)	404 (268)	374 (214)	6.1 (54)	
	1.9 (4.0)	3.8 (8.0)	390 (242)	374 (213)	8.5 (76)	
	0.9 (2.0)	1.9 (4.0)	398 (256)	379 (222)	8.0 (71)	
	0.5 (1.0)	0.9 (2.0)	404 (267)	380 (224)	8.0 (71)	
	0.2 (0.5)	0.5 (1.0)	406 (275)	381 (226)	3.0 (71)	
	0 (0)	0.2 (0.5)	414 (235)	381 (227)	6.0 (71)	
	0 (0)	0.2 (0.4)	429 (313)	382 (228)	7.7 (63)	

TABLE XX. PERFORMANCE DATA OF RIBBED CUP
TSRC-ML VIMVAK C95600 (RPL IN CASE)

SPEED RPM/Million DN	OIL FLOW L/min (pt/min) S.E. SMALL END	TEMPERATURE K (F)			TEST HEAD TORQUE N.m (lbf-in)	COMMENTS
		CUP	RIB	OIL OUT		
4000/0.26	1.9 (4.0)	340 (188)	341 (190)	358 (183)	4.3 (40)	Pre oil off
	1.9 (4.0)	359 (187)	340 (188)	358 (184)	4.3 (40)	Post oil off
11000/0.72	2.8 (6.0)	379 (223)	384 (231)	370 (206)	7.1 (63)	Pre oil off
	2.8 (6.0)	373 (212)	377 (219)	370 (207)	7.0 (62)	Post oil off
17000/1.1	3.8 (8.0)	395 (231)	401 (263)	378 (221)	10.1 (89)	Pre oil off
	3.8 (8.0)	395 (232)	403 (266)	378 (221)	9.7 (86)	Post oil off
24000/1.6	3.8 (8.0)	412 (282)	429 (304)	400 (260)	11.9 (105)	Pre oil off 5340N (1200lbf) THRUST LOAD ONLY
30000/2.0	5.7 (12.0)	429 (304)	439 (331)	403 (263)	8.0 (71)	Pre oil off 7120N (1600lbf) Thrust THRUST LOAD ONLY

TABLE XXI. OIL-OFF TEST RESULTS - RIBBED CONE DESIGN -

TSMA, TSMR and TSMR-S						
OIL-OFF TIME (minutes)						
SPEED RPM	MILLION DN	TSMA	TSMR	TSMR-S		
		JEX1292CB CBS 600 STANDARD	JEX1292CC CBS600	JEX1292CD M2 65% PM	JEX1292CD CBS 1000M 65% FM	JEX1292CD CBS 1000M 75% PM
4000	0.26	10.4	137.0+	232.0+	193.0+	568.8+
11000	0.72	*	8.3	7.1	12.8	12.4
17000	1.10	*	3.1	3.8	5.1	3.5
24000	1.56	*	12 sec	36 sec	40 sec	36 sec
30000	1.95	*	9 sec	4 sec	97 sec	11 sec
37000	2.4	*	7 sec	2 sec	*	4 sec

+ THE RUN WAS STOPPED, NO BEARING FAILURE OCCURED.
* NOT TESTED.

TABLE XXII. OIL-OFF TEST RESULTS - RIBBED CUP DESIGN -

		TSRC, TSRC-ML and TSRC-S				
		OIL-OFF TIME (minutes)				
SPEED RPM	MILLION DN	TSRC	TSRC-ML	TSRC-S		
		JEX1292CE CBS 600	JEX1292CG CBS 600 MPL	JEX1292CF M2 65% PM	JEX1292CF CBS 1000M 65% PM	JEX1292CF CBS 1000M 75% PM
4000	0.26	30.0+	30.0+			31.6+
11000	0.72	33.5+	30.0+	33.0+	8.5	105.0+ 30.0+
12000	0.78			22.1 5.3	18.1# 15.2 13.5 10.8 6.5#	10.0 9.8 7.2
13000	0.84				10.0 4.0	
17000	1.10	45 sec	40 sec	20 sec	135.0++	1.5 45.0 sec 30.0 sec
24000	1.56	15 sec	10 sec	*	*	*
30000	1.95	7 sec	4 sec	*	*	*
37000	2.40	*	*	*	*	*

+ THE RUN WAS STOPPED. NO BEARING DAMAGE OCCURED.
 * NOT TESTED BECAUSE OF SHORT TIMES ON PRECEDING RUNS.
 # ELECTRO-ETCHED PM RIB FACE.
 ++ SUBSEQUENTLY DETERMINED THAT SOME OIL LEAKED INTO THE BEARING.

Table XXIII - Microhardness of Rib Ring

	<u>Hardness (HRC)*</u>
As Heat Treated	58-60 HRC
As Ground and Etched	45-50 HRC
After "Break-In" Run With Oil	Approx. 50 HRC
After "Oil-Off" Run Without Oil	Approx. 52 HRC

* Converted to Rockwell C scale from microhardness measurements by Leitz microhardness tester.

Table XXIV - Retained Austenite in Rib Rings Determined
by X-Ray Diffraction

<u>Sample No.</u>	<u>Condition</u>	<u>Amount of Retained Austenite</u>
84-63	As ground and acid etched <u>at surface</u>	Nil
84-58	As ground and acid etched <u>at surface</u>	Nil
84-89	As ground and acid etched <u>at surface</u>	Nil
84-55	Break-in run with oil at 30,000 rpm <u>at surface</u>	Nil
84-53	Break-in run with oil at 24,000 rpm <u>at surface</u>	Nil
84-57	Oil-off test at 17,000 rpm for 1.0 min. <u>at surface</u>	38%
84-57	Oil-off test at 17,000 rpm for 1.0 min. <u>away from surface</u>	Nil

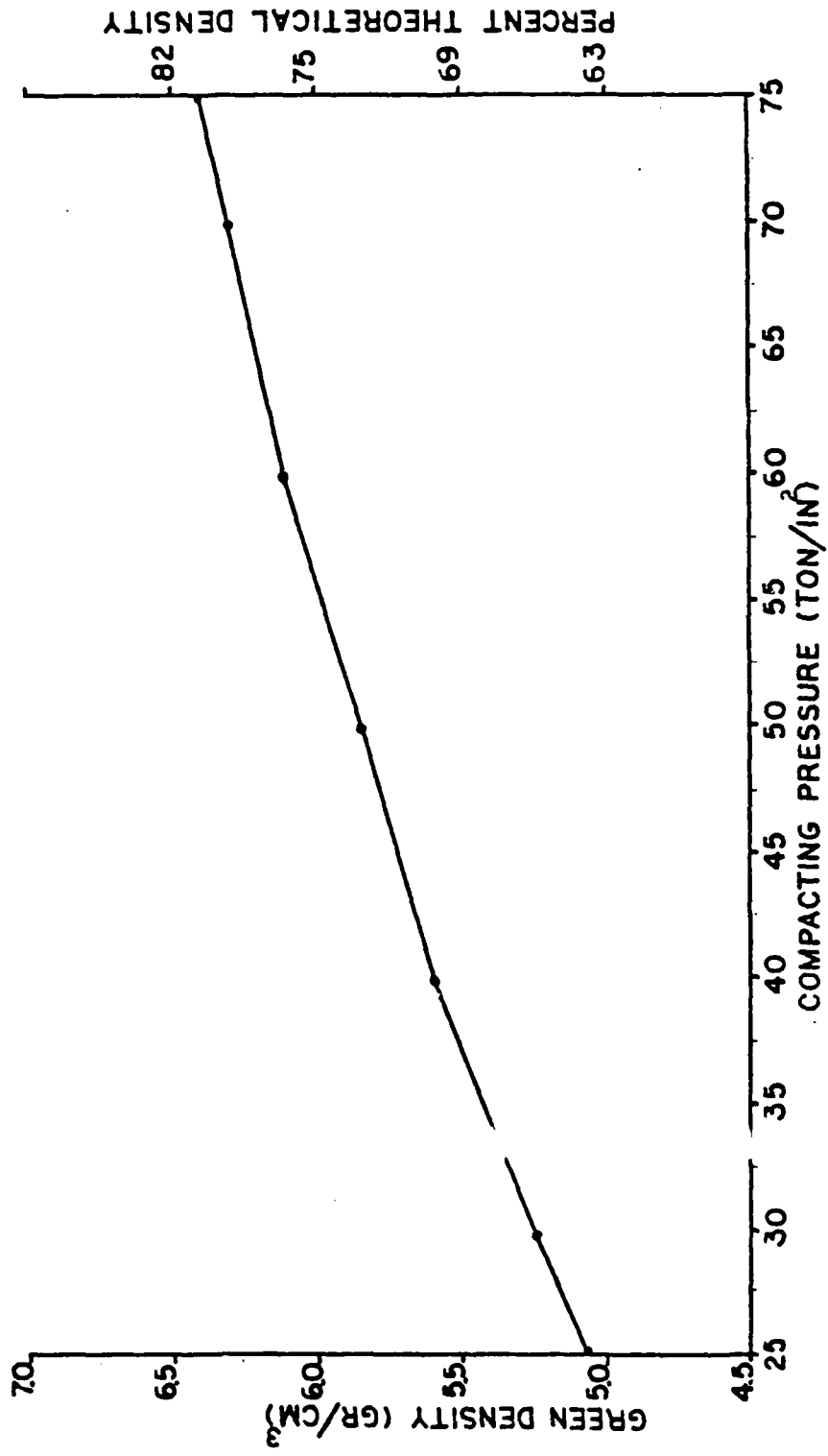

Figure 1 - Compacting Curve for Annealed CRS1000M Steel Powder

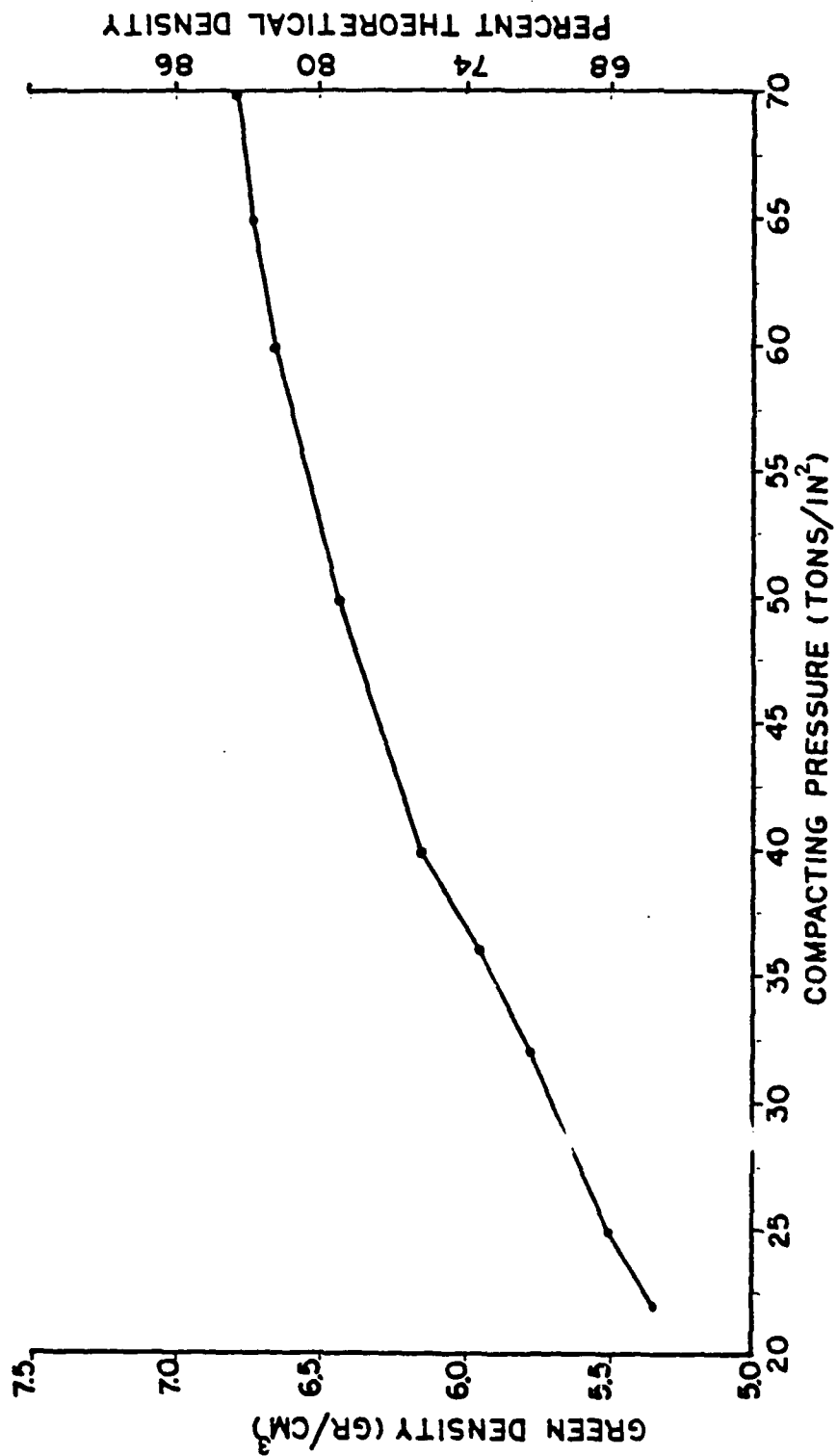

Figure 2 - Compacting Curve for Commercially Available Annealed
M2 High Speed Steel Powder

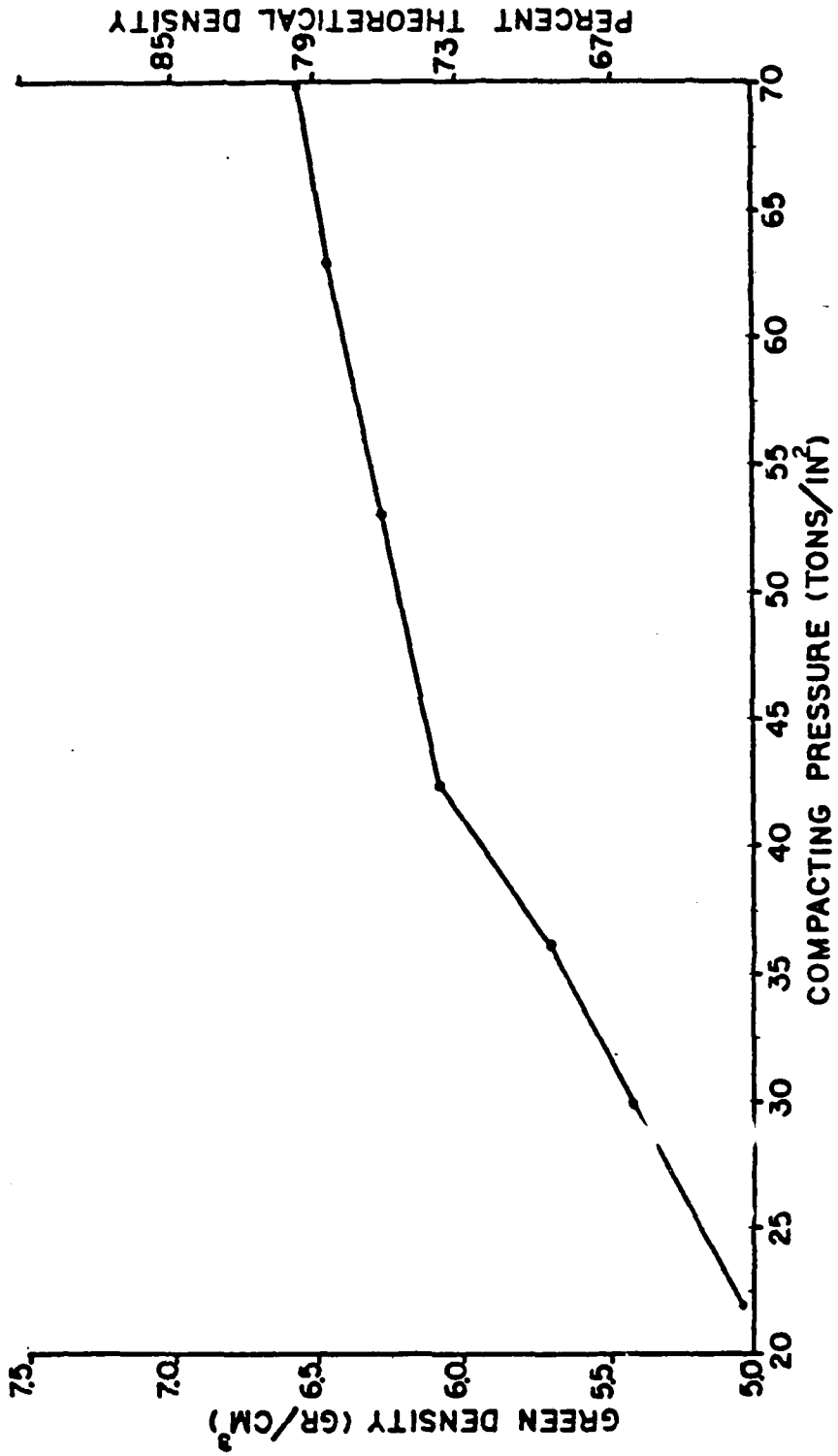
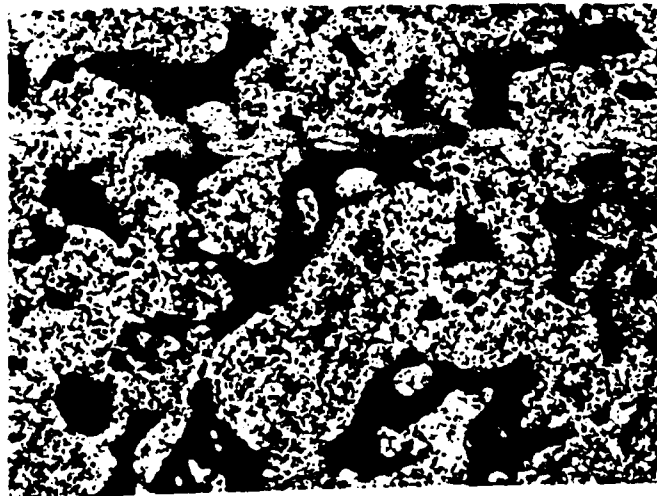
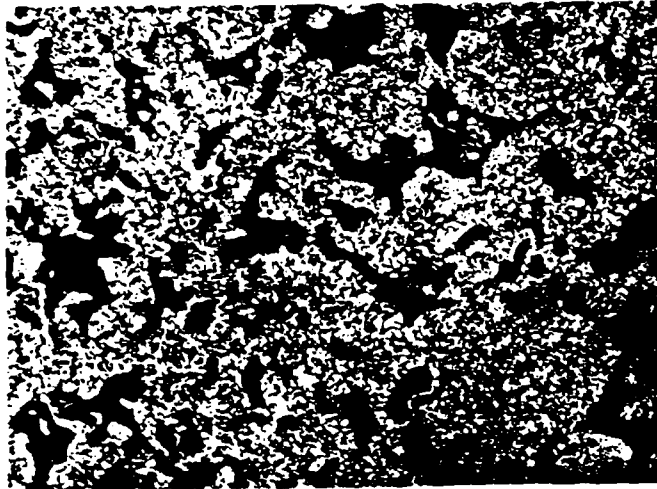

Figure 3 - Compacting Curve for Annealed T15 High Speed Steel Powder



MATERIAL: CBS-1000M
DENSITY: 70% OF THEORETICAL
MAG: 500X
PHOTO NO: 1716-83



MATERIAL: M-2 HIGH SPEED STEEL
DENSITY: 75% OF THEORETICAL
MAG: 500X
PHOTO NO: 1717-83

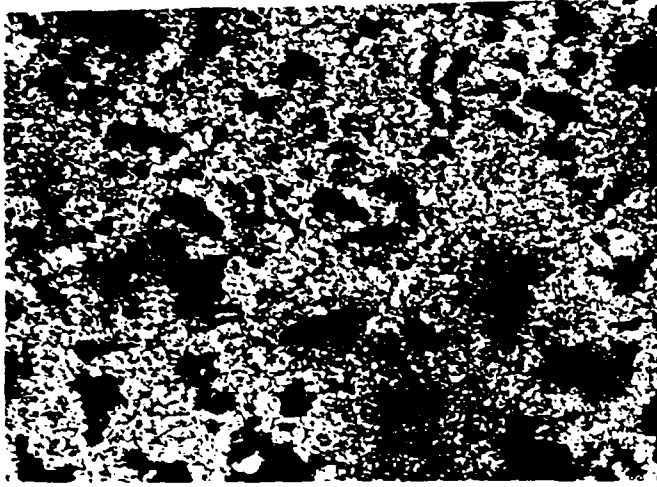

MATERIAL: T-15 HIGH SPEED STEEL
DENSITY: 75% OF THEORETICAL
MAG: 500X
PHOTO NO: 1715-83

FIGURE 4. TYPICAL PORE AND CARBIDE DISTRIBUTION OF THE PRESSED, SINTERED, HARDENED, AND TEMPERED WEAR TEST BLOCKS

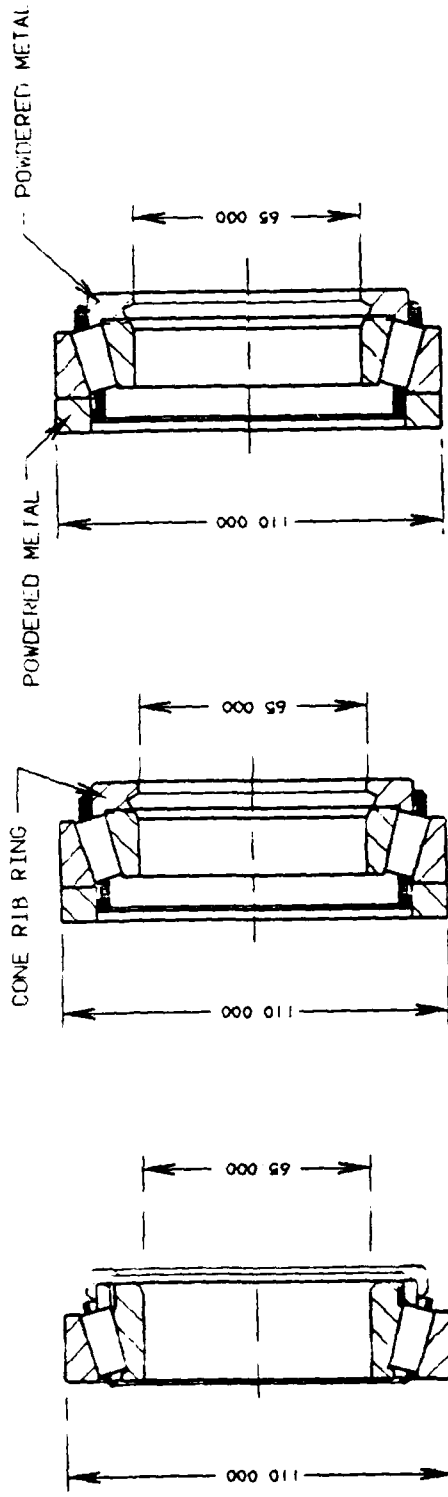

JEX1292CB TSM

JEX1292CC-JEX1292DB TSMR

JEX1292C1-JEX1292DB TSMR-S

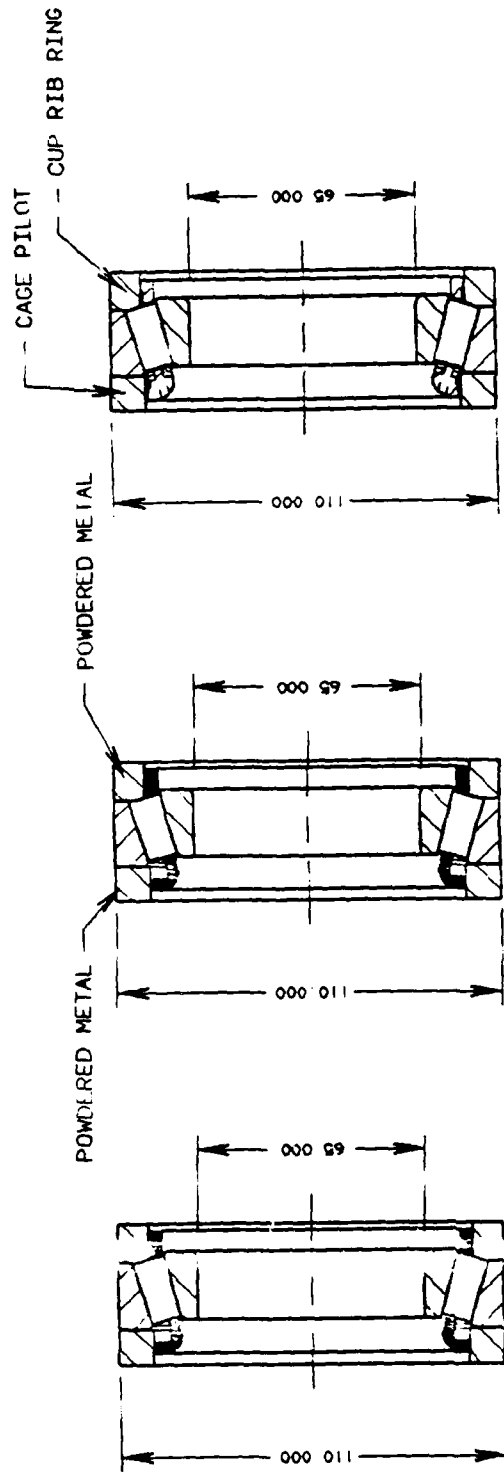

JEX1292CE-JEX1292DB TSM

JEX1292CF-JEX1292DB TSMR-S

JEX1292CG-JEX1292DB TSMR-ML

FIGURE 5 TEST BEARING STYLES

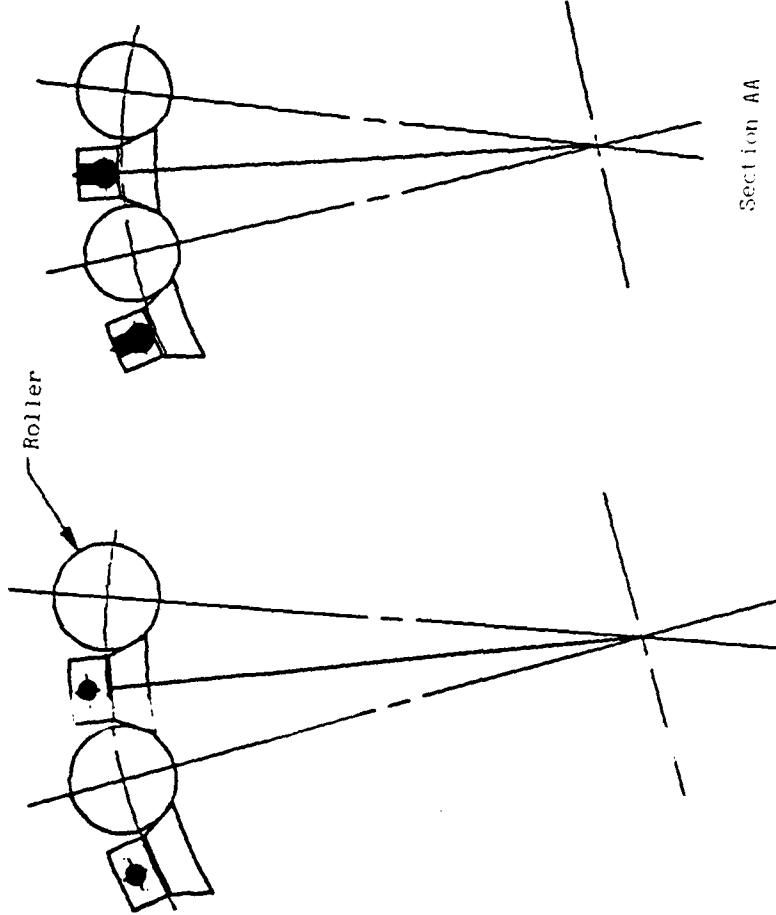
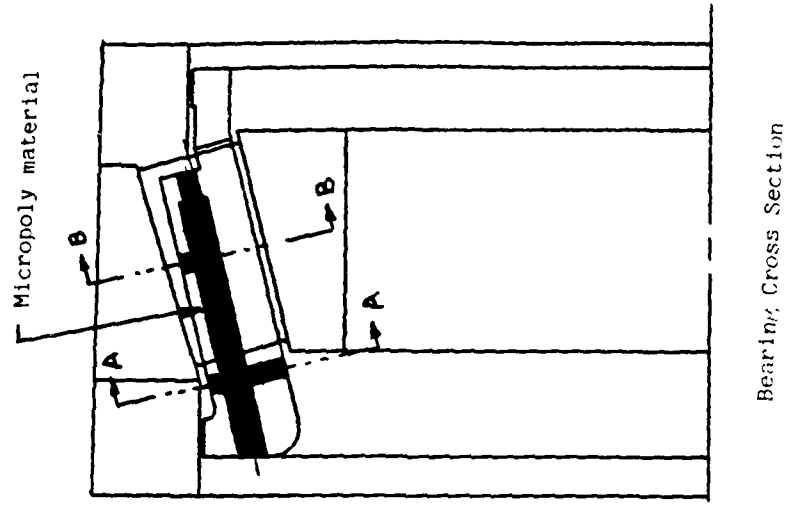
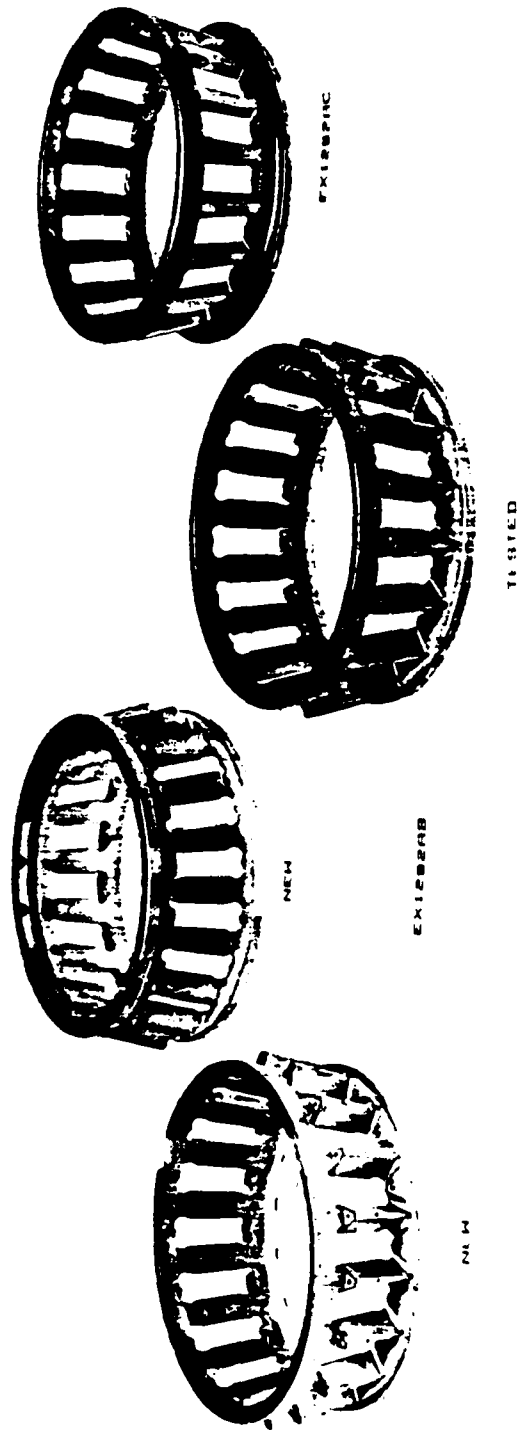
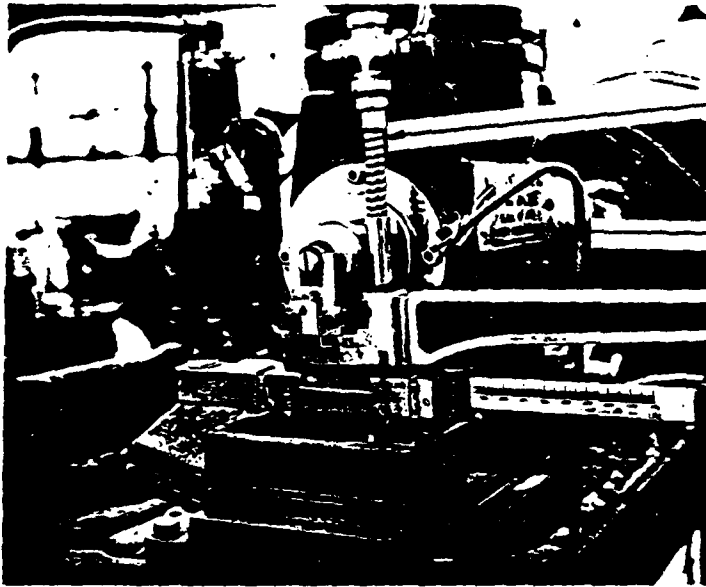

Figure 6 - EX1292AB TSRC-MI, Case

Figure 7
EX1292AB Cages with Microporous
Polymer Lubricant and EX1292AC
Standard Cage





Oil Supply

Air Purge

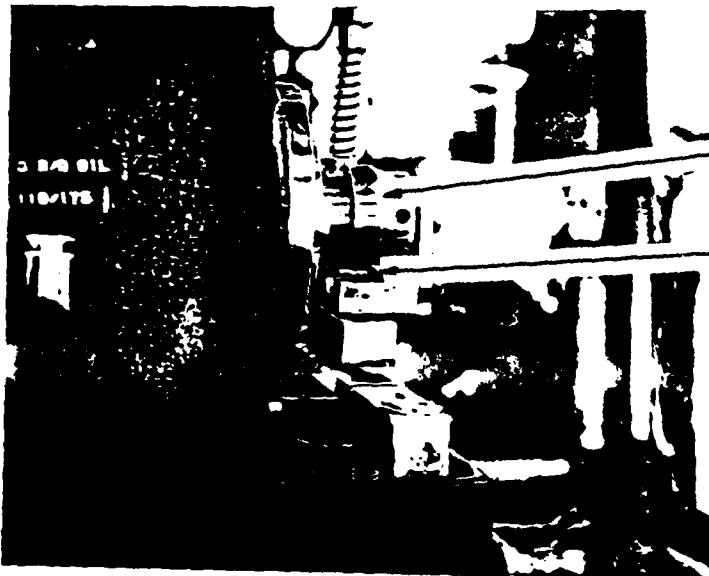

Test Cup

Test Block

Figure 8 - Timken Lubricant and Wear Test Machine

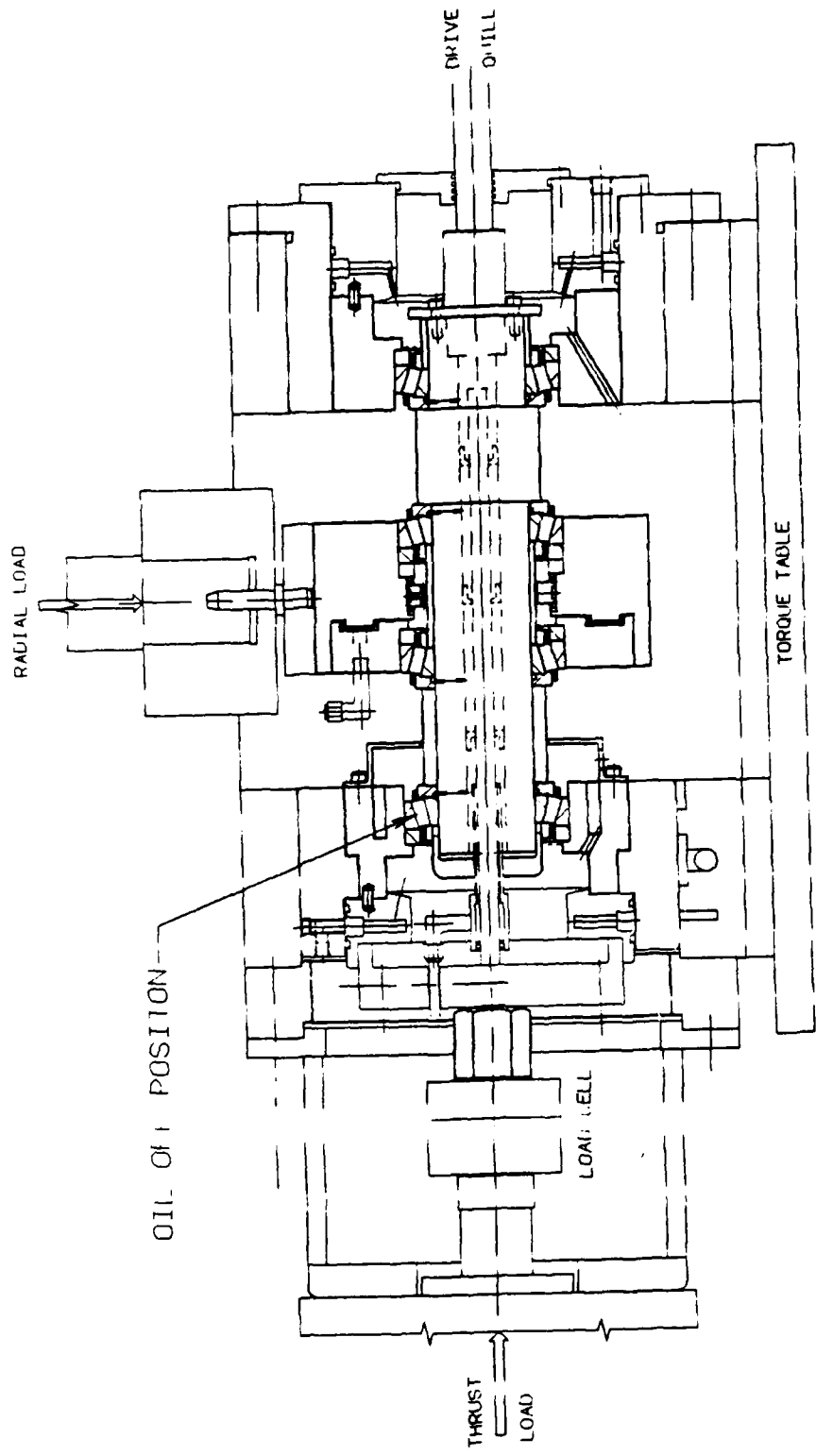
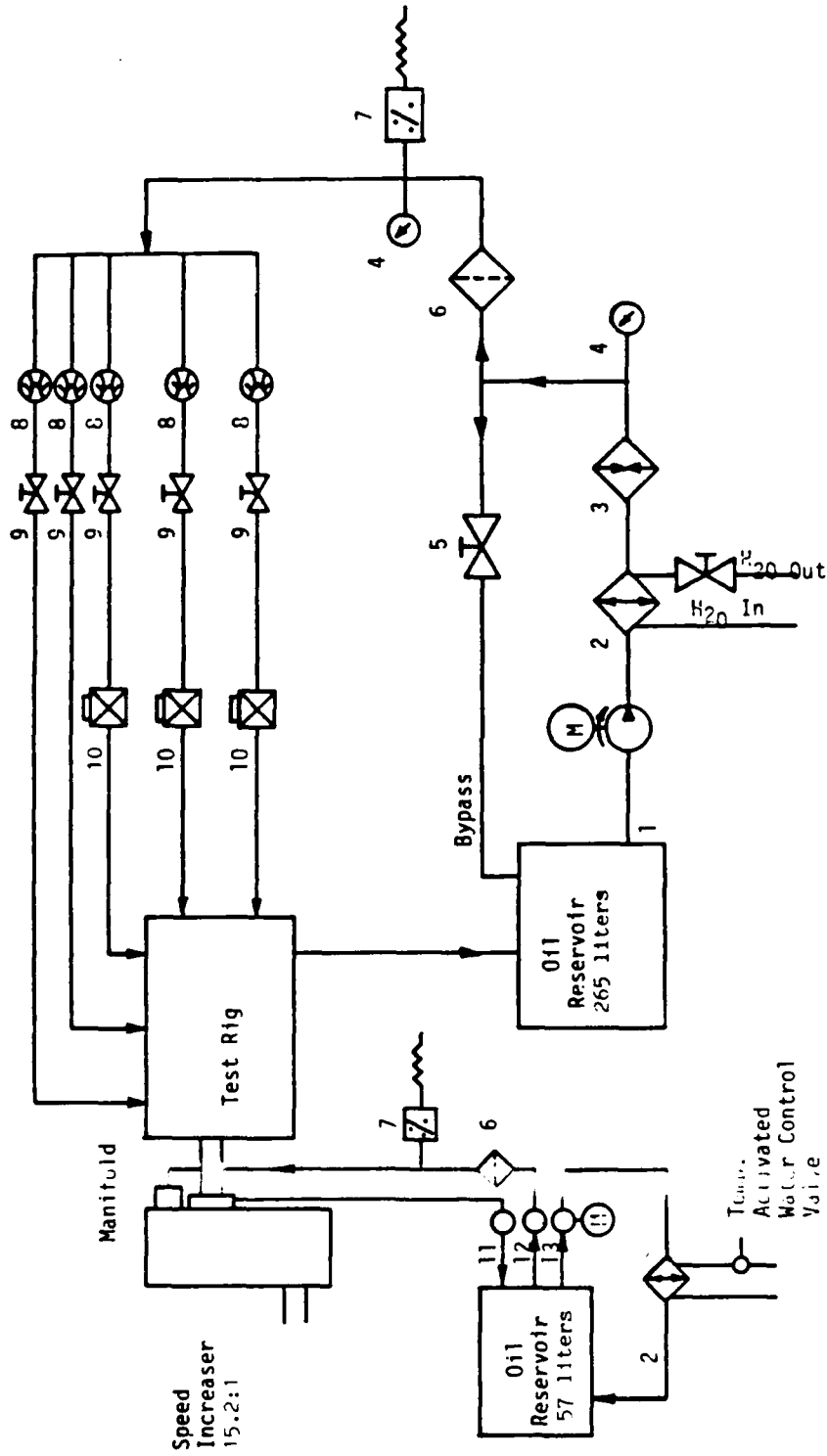

FIGURE 9 TEST RIG CROSS SECTION



- | | |
|---------------------|-----------------------------|
| 1. Pump | 7. Pressure Relief Valve |
| 2. Heat Exchanger | 8. Turbine Oil Flow Meter |
| 3. Immersion Heater | 9. Adj. Flow Control Valve |
| 4. Pressure Gage | 10. Solenoid Shut Off Valve |
| 5. Bonnet Valve | 11. Scavenger Pump |
| 6. Filter | 12. Pressure Pump |
| | 13. Circulation Pump |

Figure 10 - Lubrication System for Test Rig

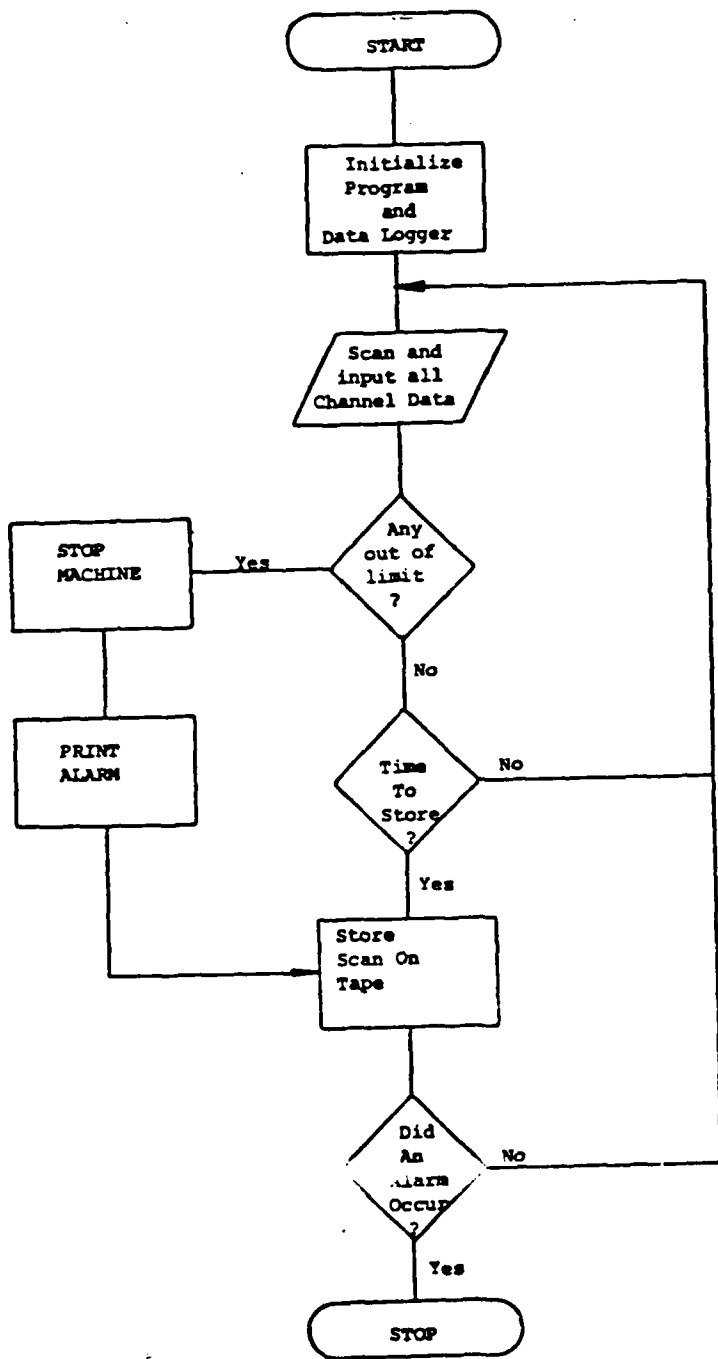
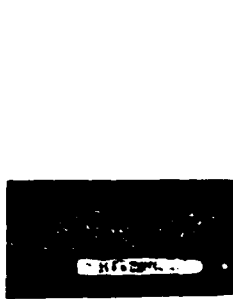
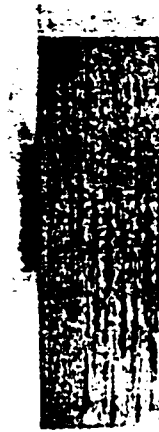
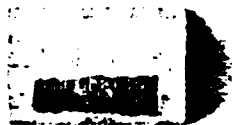

Figure 11 Data Acquisition Flow Chart



(a) CBS 1000M Test Block
and CBS 600 Ring

(b) Silicon Nitride Test
Block and CBS 600 Ring



(c) Standard Material - SAE 4319 Test
Block and SAE 8720 Test Ring

Figure 12 - Photograph Showing Post Test Condition of (a) CBS 1000M Block With CBS 600 Ring, (b) Silicon Nitride Test Block With CBS 600 Ring, and (c) Standard Case Carburized Bearing Material

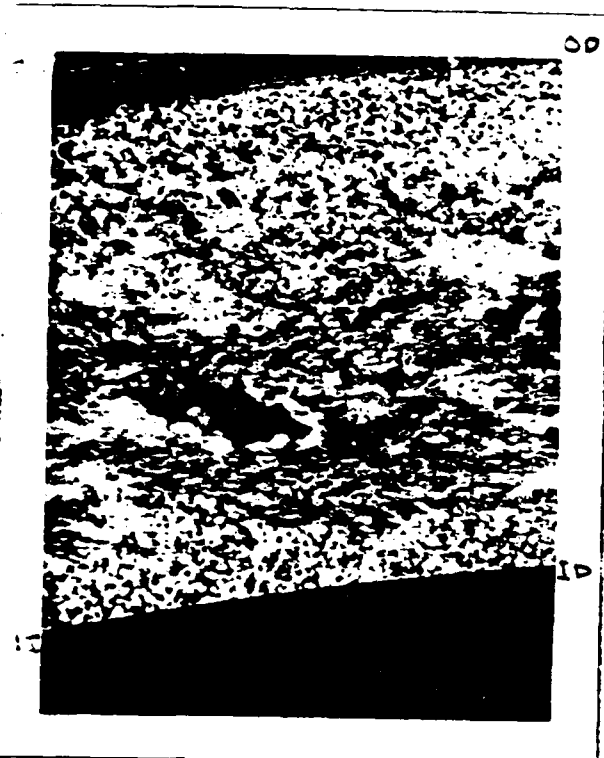

Rib No. 84-77
Damaged at 24000 rpm(1.6 million DN)
(25X Magnification)



Rib No. 84-78
Damaged at 30000 rpm(2.0 million DN)
(25X Magnification)

Figure 13 Damaged TSRC-S CBS1000M 65% Density Cup
Rib No. 84-77 and 84-78.

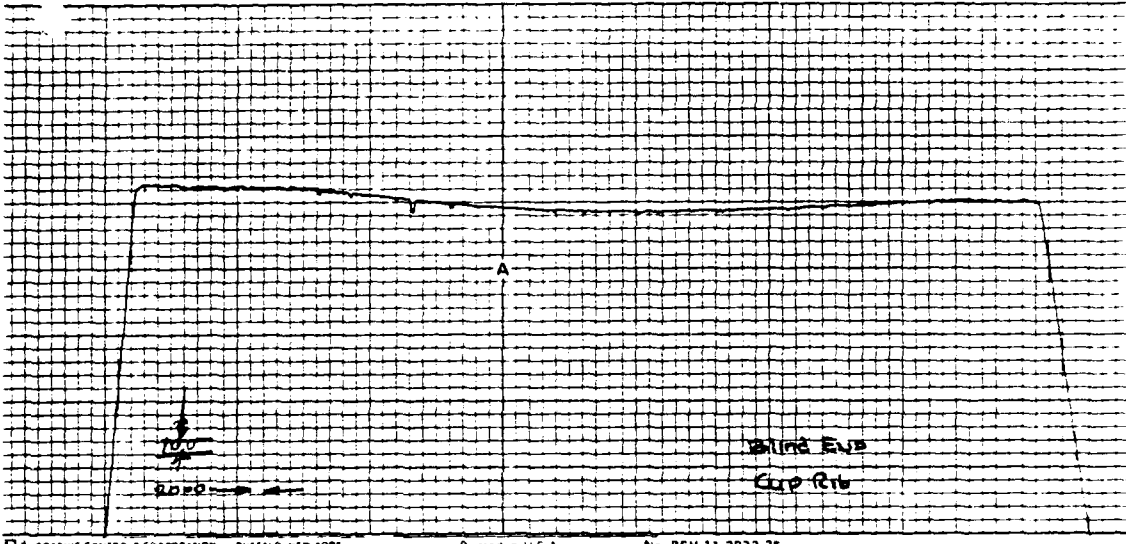

CBS 600

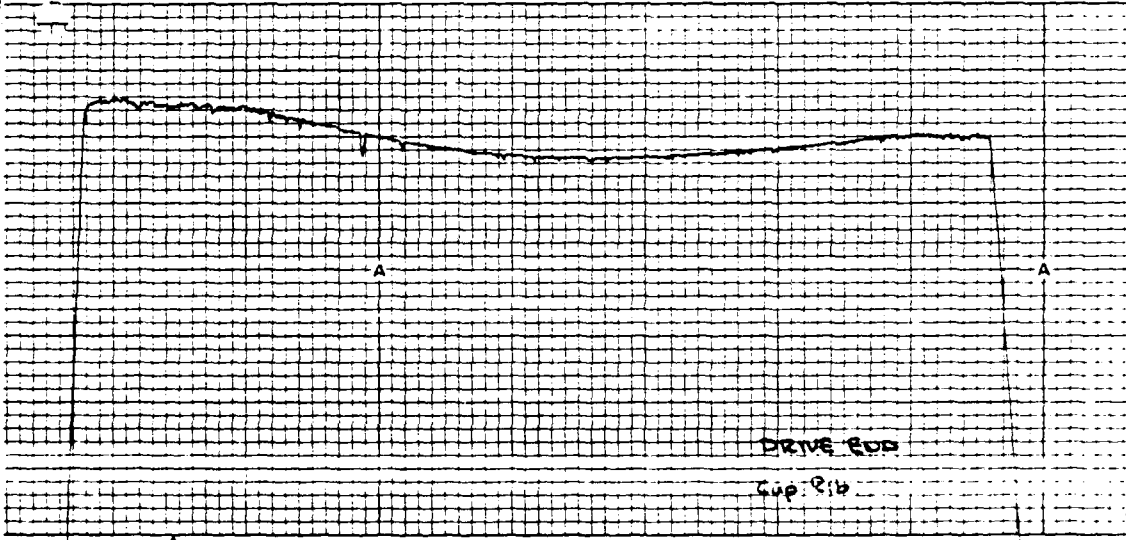

PROFILE	<input checked="" type="checkbox"/>	PROFILE	<input type="checkbox"/>	DATE	8-5-30	
FINISH	<input type="checkbox"/>	ROUGHNESS	<input type="checkbox"/>	PART	122 RE Rib Ring	
A. GAGE	<input type="checkbox"/>	AVERAGE	<input checked="" type="checkbox"/>			

Figure 14 - JEX1292CE, TSRC, CBS600 Cup Rib Wear

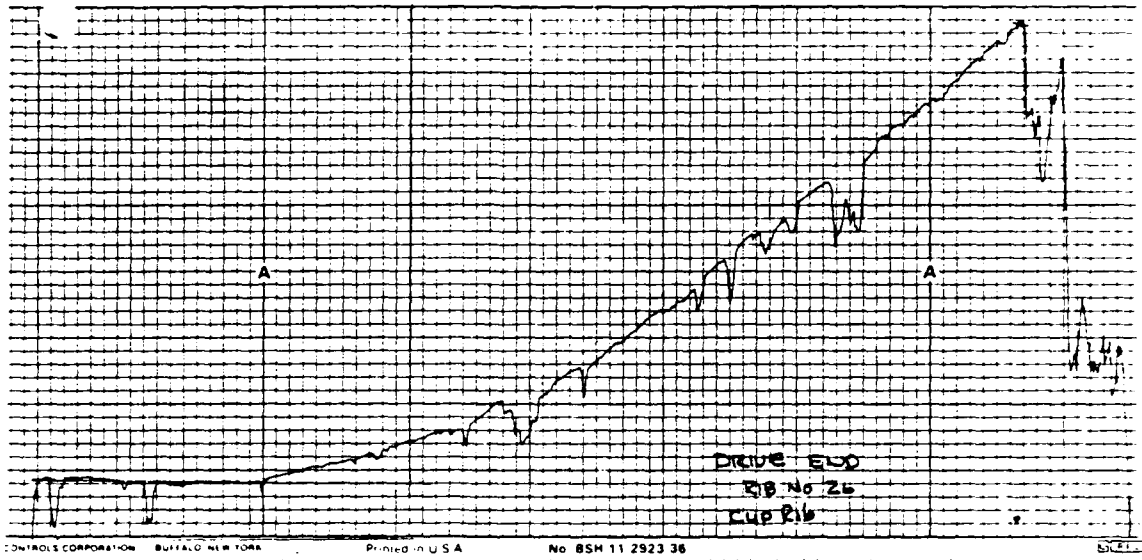

M2 RUN 1

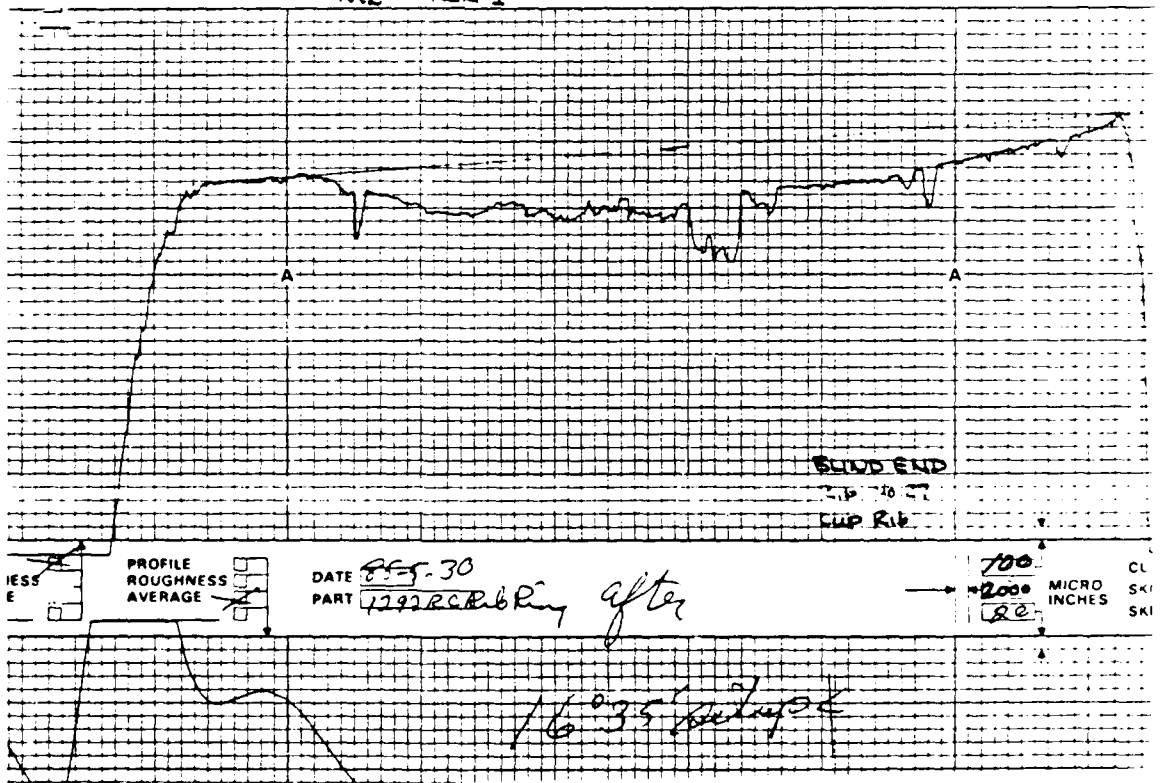
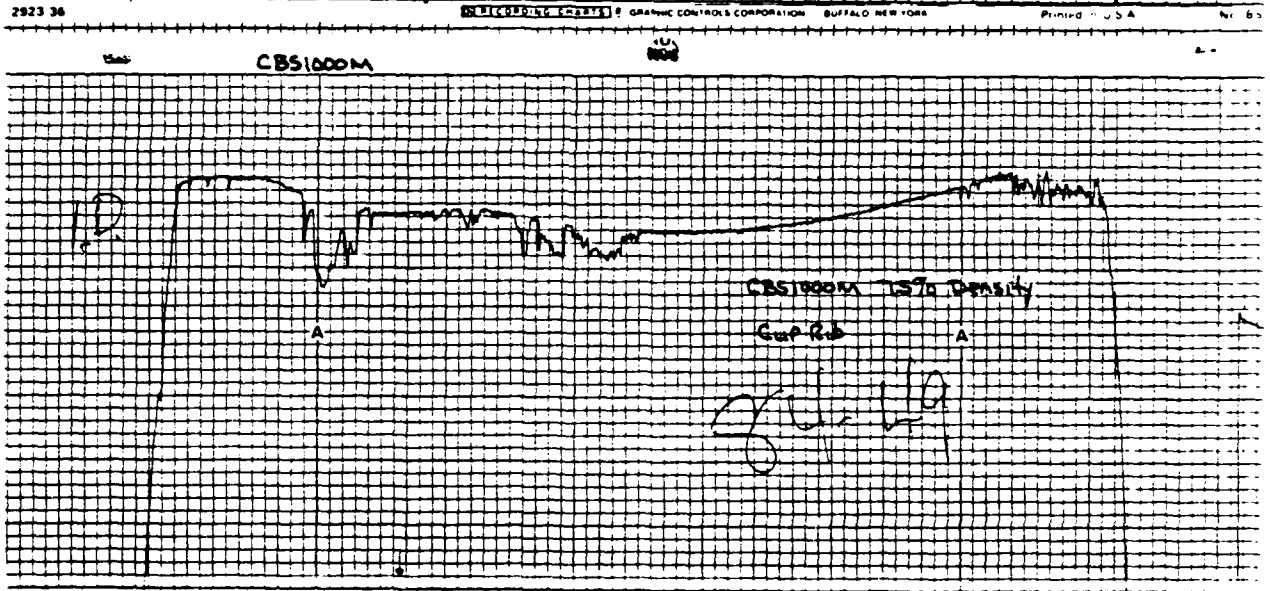
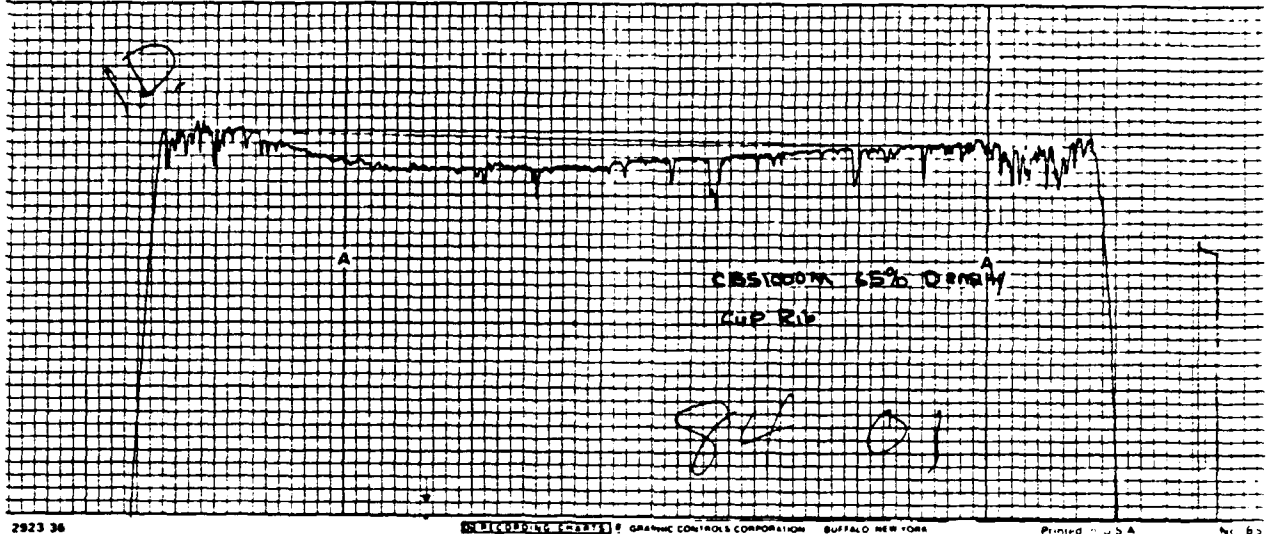

Figure 15 - JEX1292CF, TSRC-S, M2 H.S.S. 65% Density Cup Rib - ar



50 1000

CHOOSE ONE PROFILE

ROUGHNESS AVERAGE SKID SKIDLESS

STEP PROFILE ROUGHNESS AVERAGE

DATE 05-16-27 PART RIB RING AFTER USE

Figure 16 - JEX1292CF, TSRC-S, CBS1000M 65% and 75% Density Cup Rib Wear

Figure 17 - TEMPERATURE and TORQUE vs FLOW RATE at 24000 RPM
CBS1000M 75% and CBS 600 RIBBED CUP

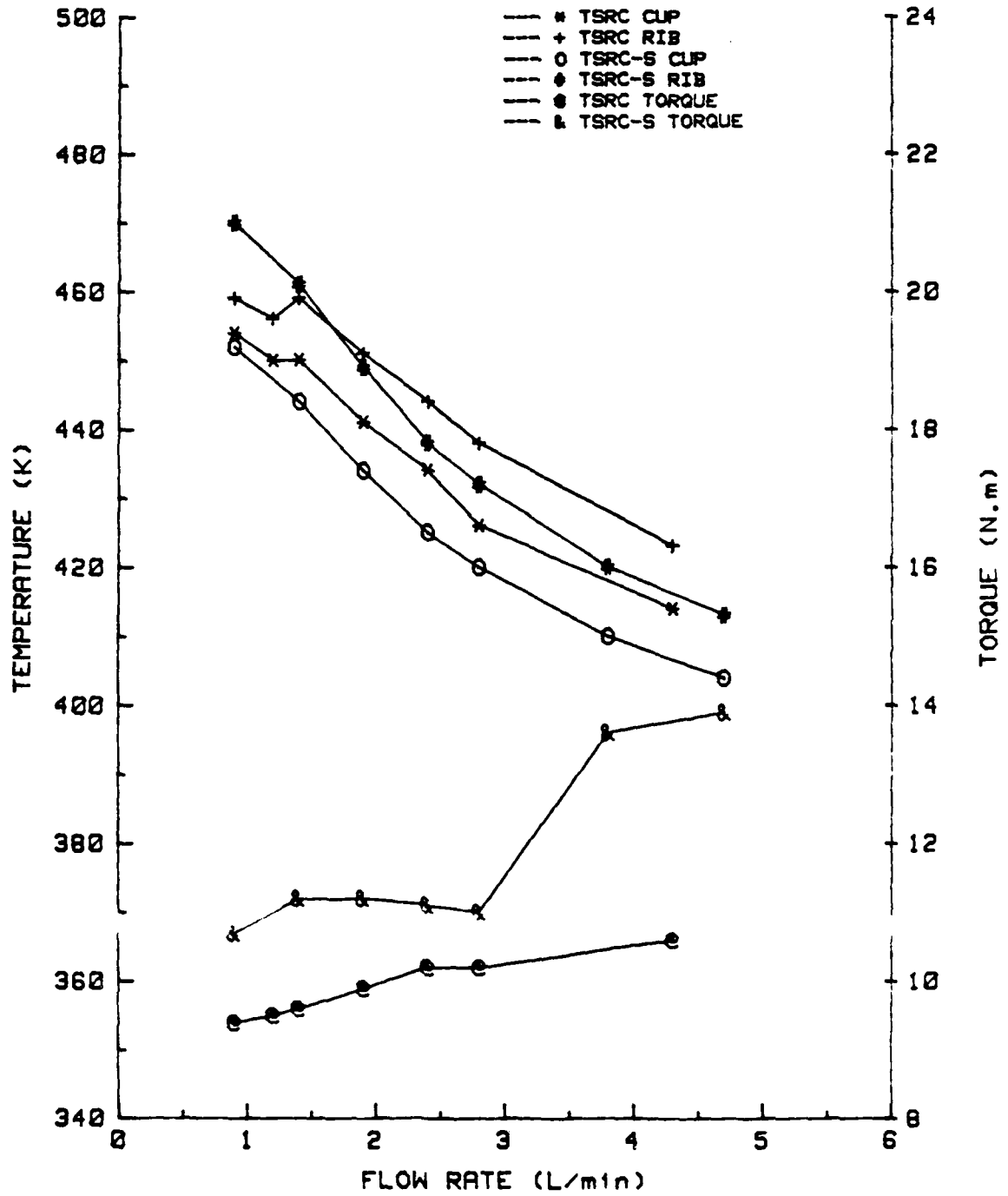

Figure 13
JEX1292CD, TSMR-S, CBS1000M
75% Density Damaged at 37,000
rpm (2.4 million DN)

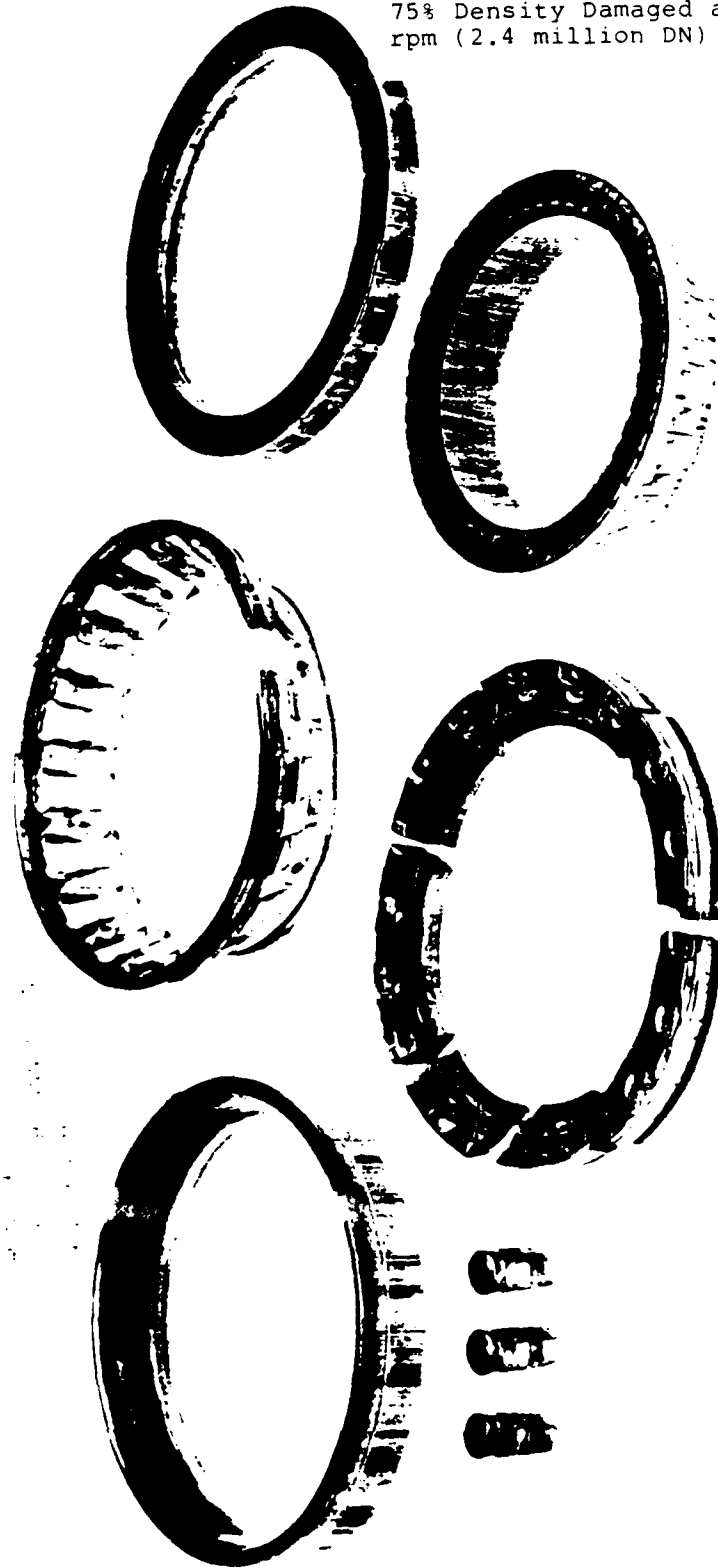

Figure 19
JEX1292CC, TSMR, CBS600, 8.3
Minutes Oil-Off at 11,000 rpm
(0.72 million DN)

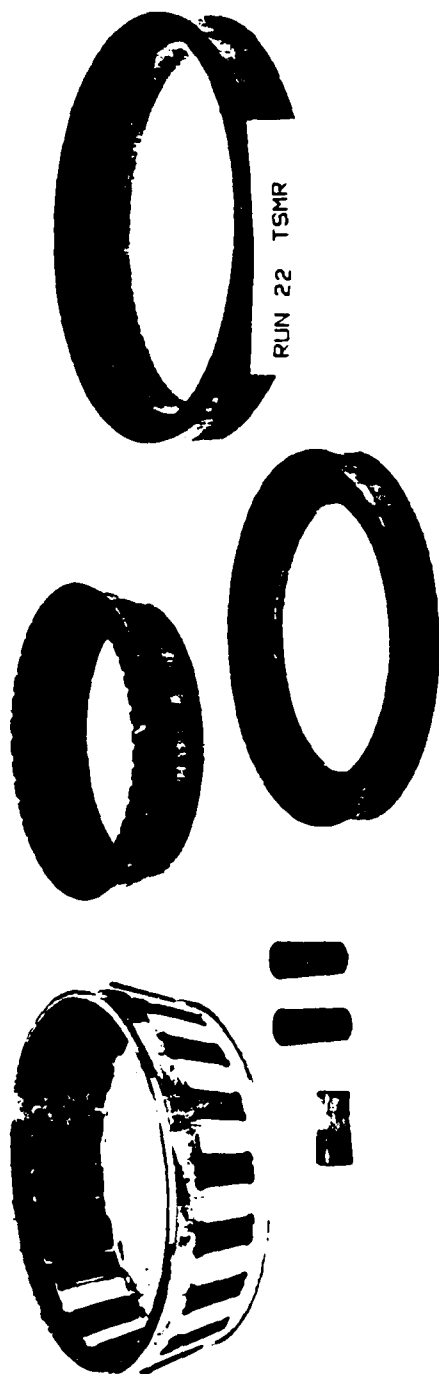

Figure 20
JEX1292CD, TSMR-S, M2 H.S.S.
65% Density, 7.1 Minutes Oil-Off
at 11,000 rpm (0.72 million
DN)

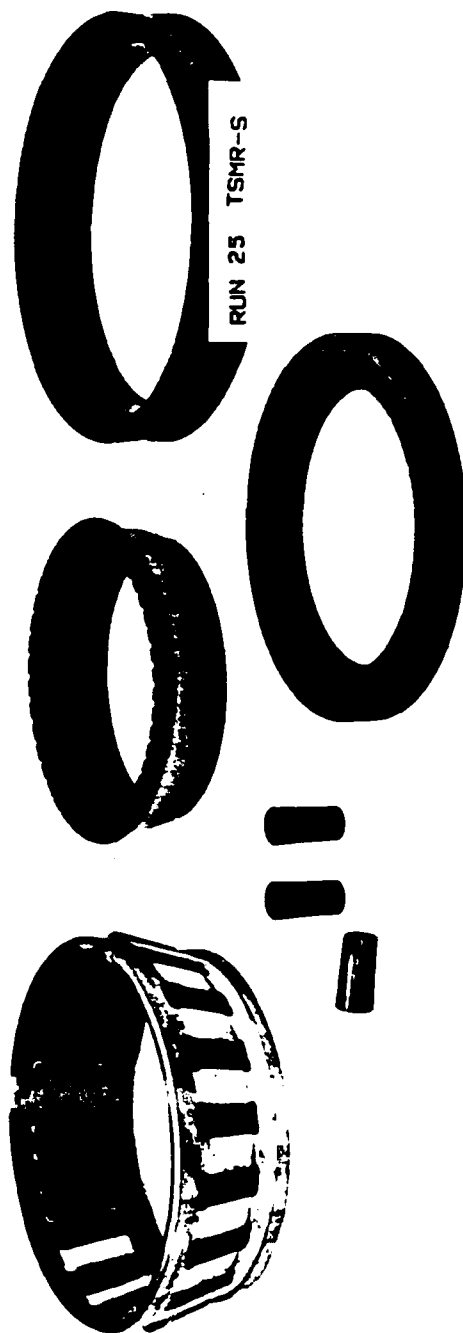

Figure 21
JEX1292CD, TSMR-S, CBS1000M
65% Density, 12.8 Minutes Oil-Off
at 11,000 rpm (0.72 million
DN)

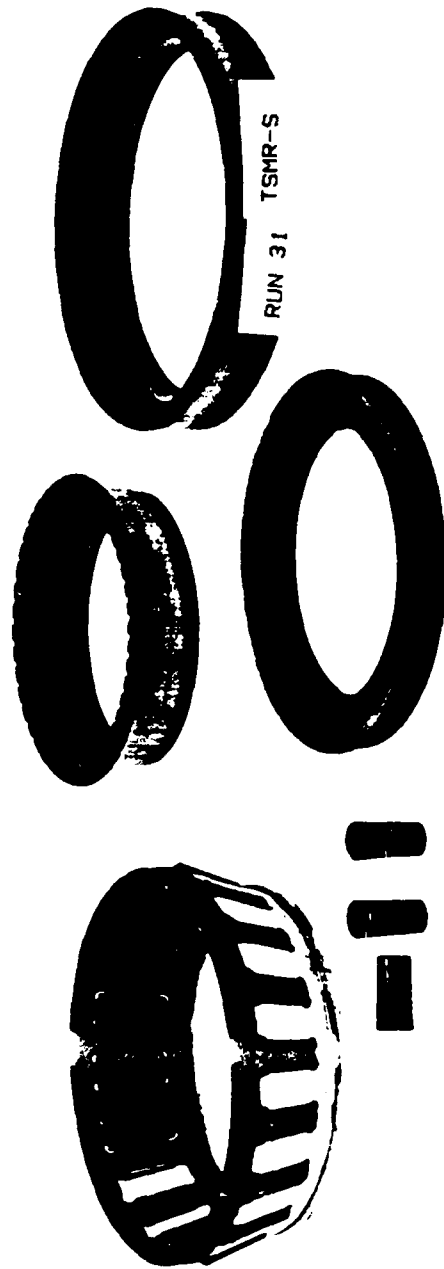

Figure 22

JEX1292CD, TSMR-S, CBS1000M
75% Density, 12.4 Minutes Oil-Off
at 11,000 rpm (0.72 million
DN)

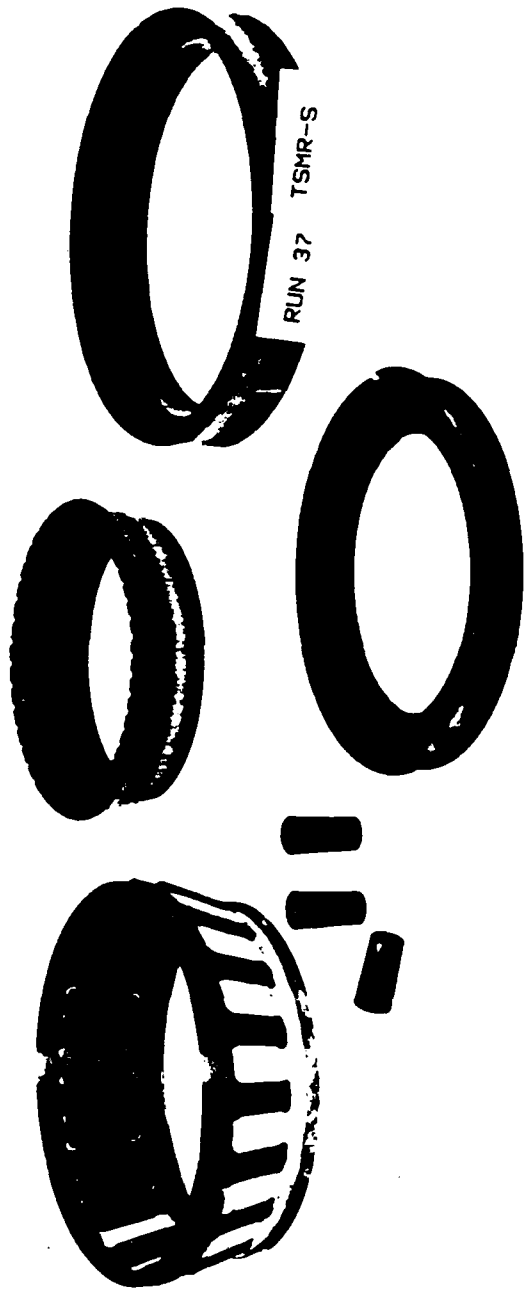

Figure 23
JEX1292CD, TSMR-S, CBS1000M
65% Density, 5.1 Minutes Oil-Off
at 17,000 rpm (1.1 million DN)

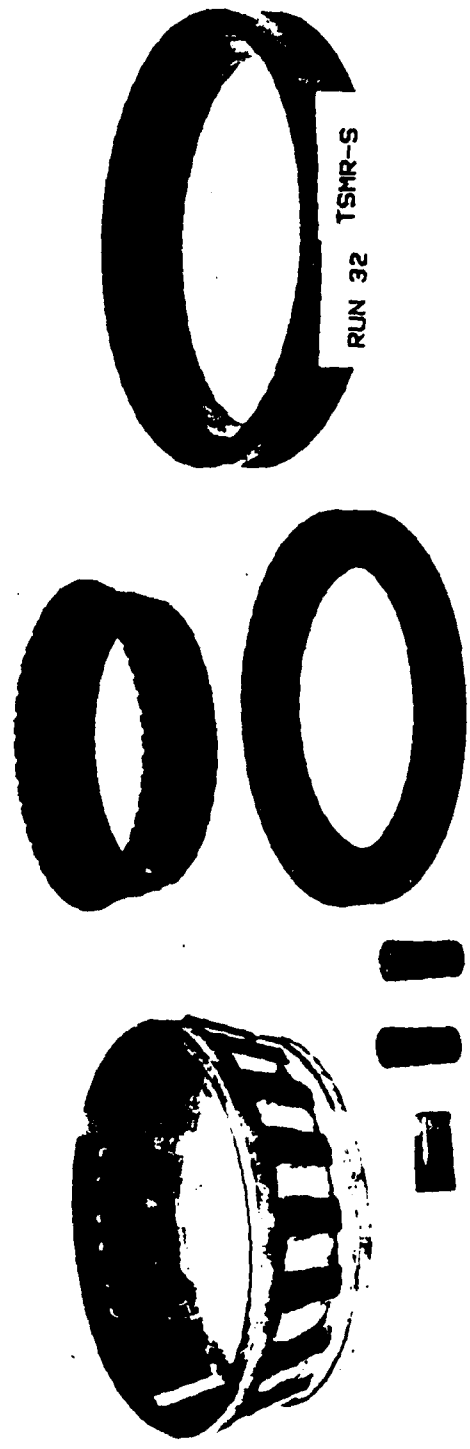

Figure 24
JEX1292CF, TSRC-S, M2 H.S.S.
65% Density, 22.1 Minutes Oil-Off
at 12,000 rpm (0.78 million
DN)

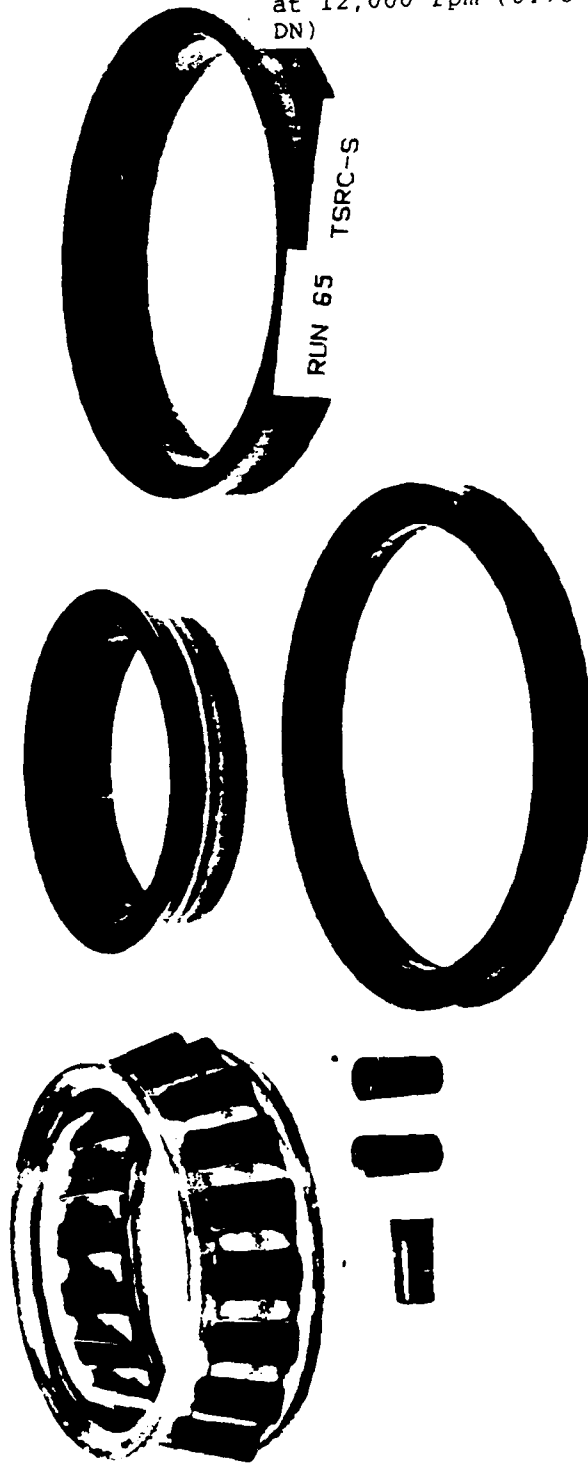

Figure 25
JEX1292CF TSRC-S, CBS1000M 65%
Density, 18.1 Minutes Oil-Off
at 12,000 rpm (0.78 million
DN)

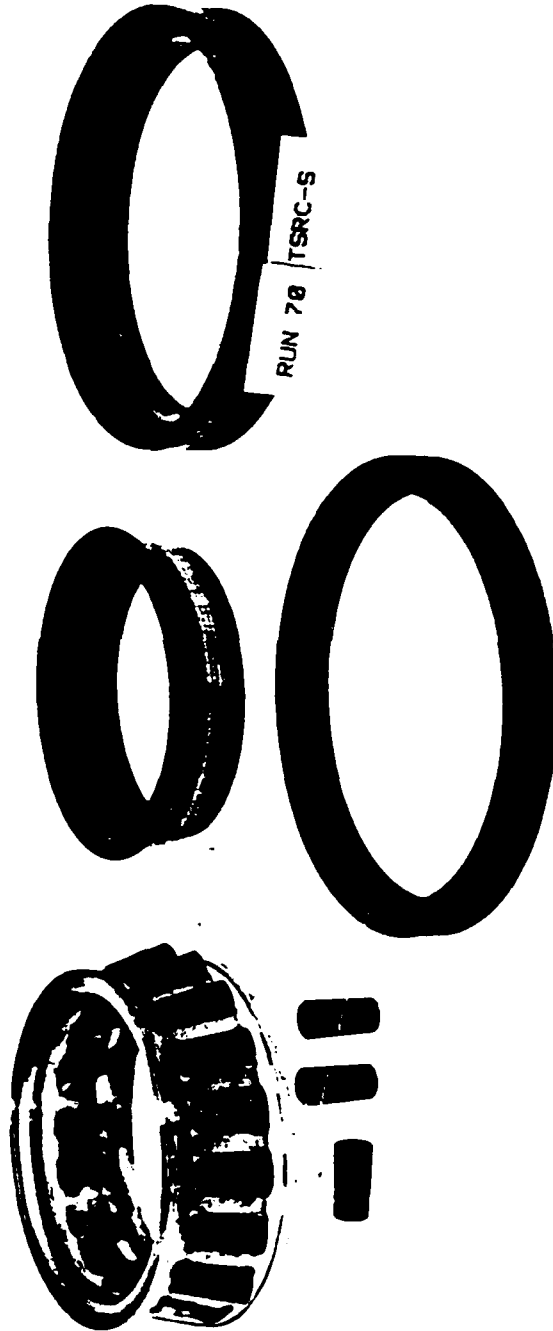

Figure 26
JEX1292CF, TSRC-S, CBS1000M
75% Density, 11.2 Minutes Oil-Off
at 12,000 rpm (0.73 million
DN)

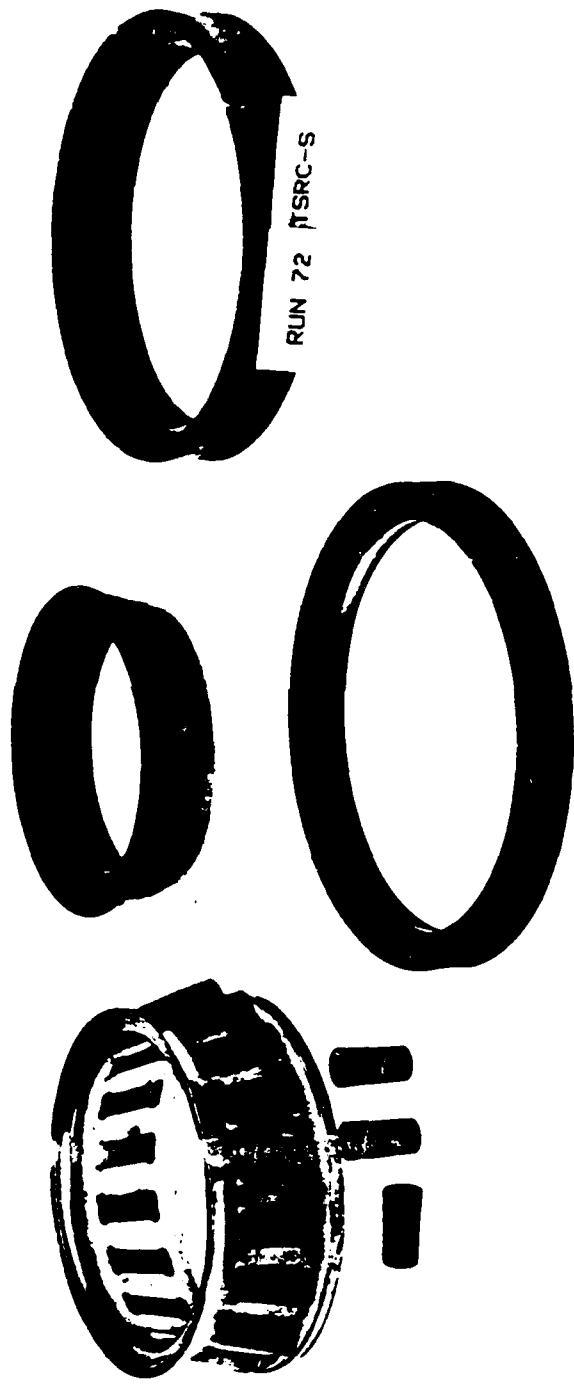

Figure 27
JEX1292CF, TSRC-S CBS1000M 65%
Density, Electro-Etched Rib
Face Oil-Off at 12,000 rpm (0.78
million DN)

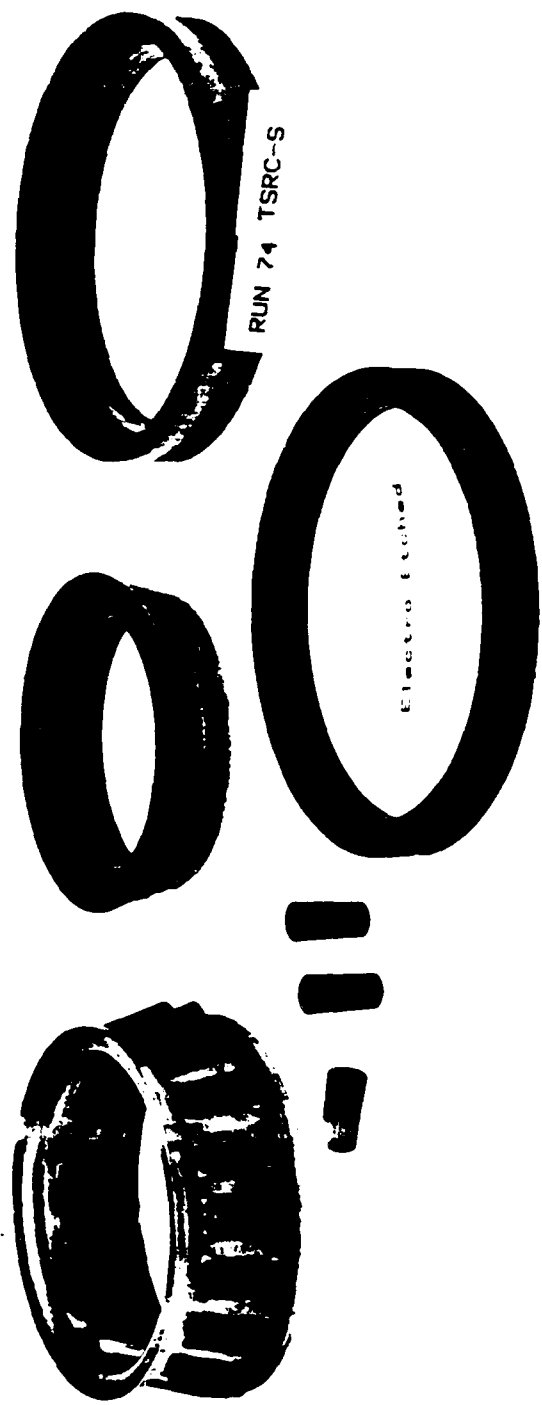

Figure 28. OIL-OFF TEMPERATURE and TORQUE vs TIME
 AT 11000 RPM. TSRC-S CBS1000M 65% DENSITY

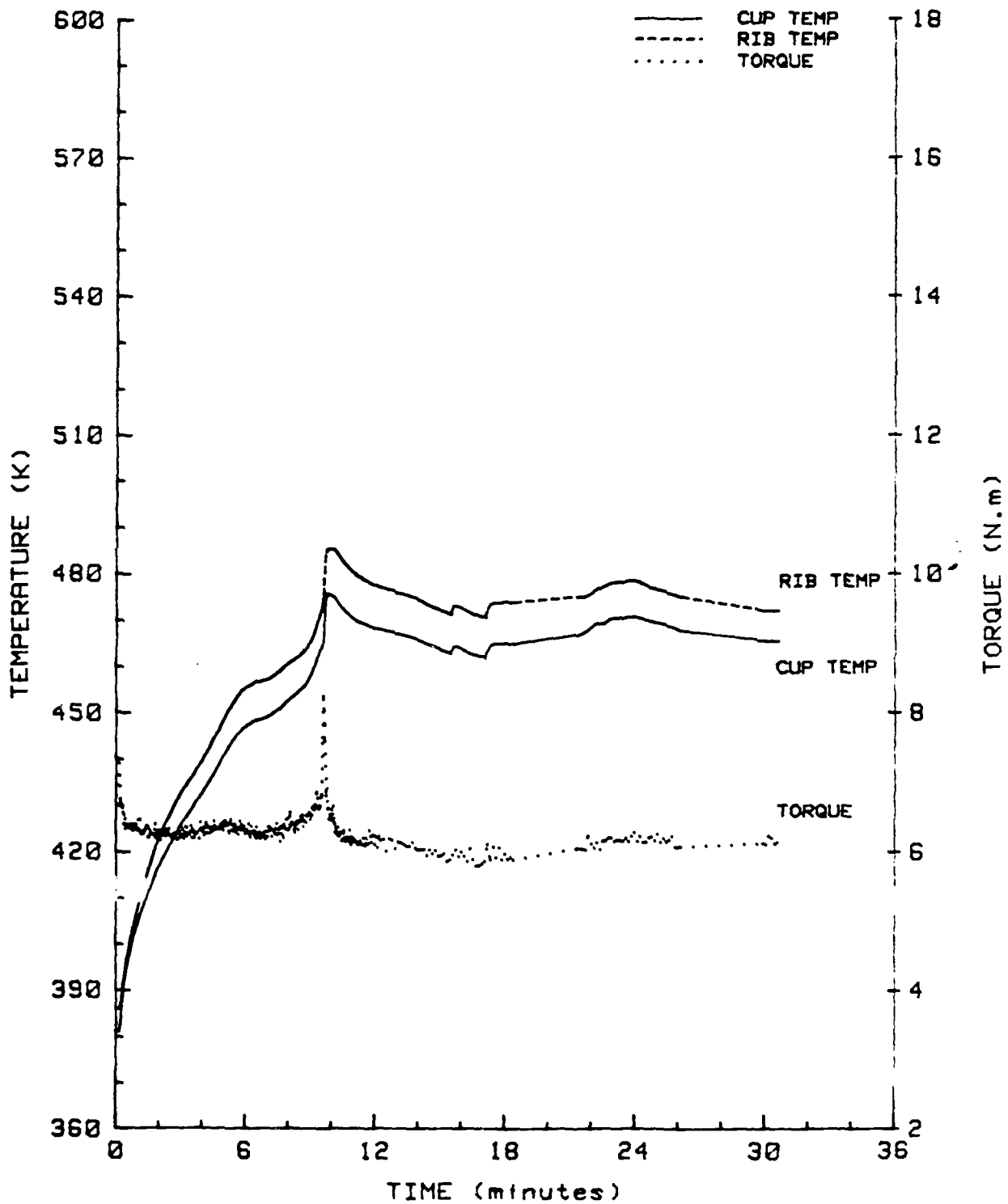
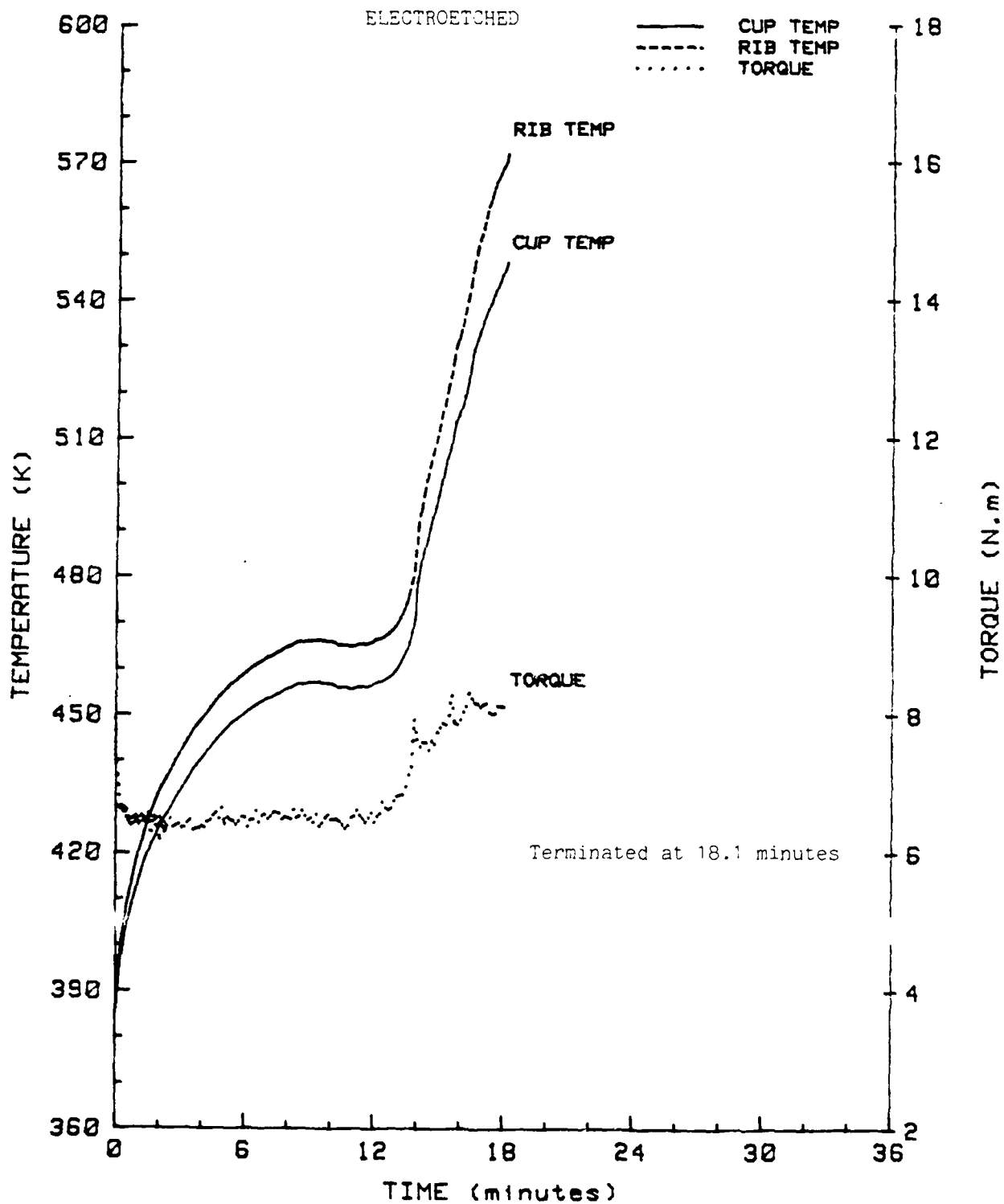
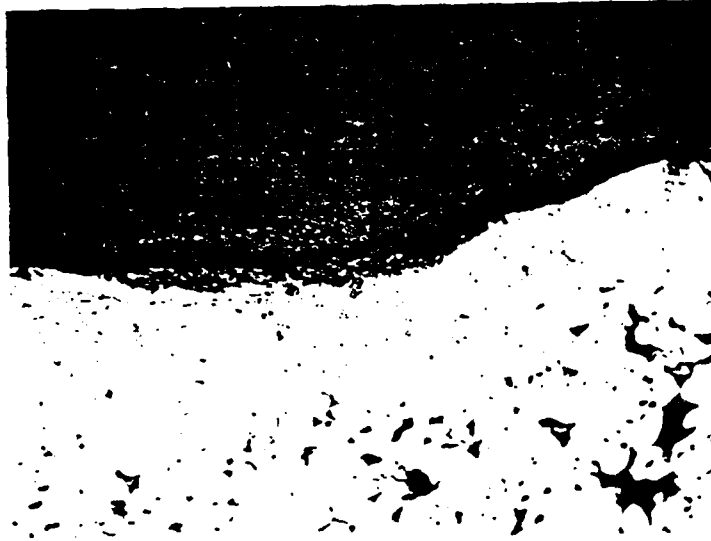

Figure 29. OIL-OFF TEMPERATURE and TORQUE vs TIME
 AT 12000 RPM. TSRC-S CBS1000M 65% DENSITY





MAG. = 200X

Photo No. 70419

(a)

Note a significant amount of densified layer (up to 0.020") and oxide layer along rib surface.

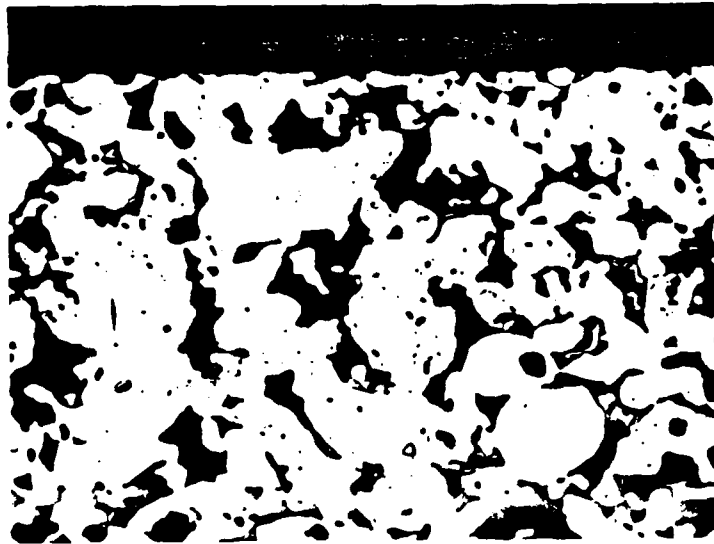

MAG. = 200X

Photo No. 70421

(b)

Figure 30 - CBS1000M P/M rib ring after oil-off test.

(a) On rib face.

(b) Away from rib face.

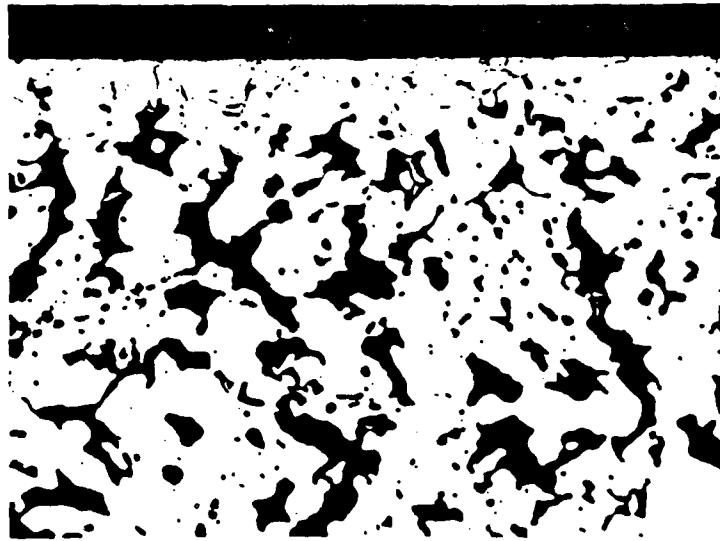

MAG. = 200X

Photo No. 70467

(a)

Note collapsed pores ($\sim 0.002''$) along the rib surface.

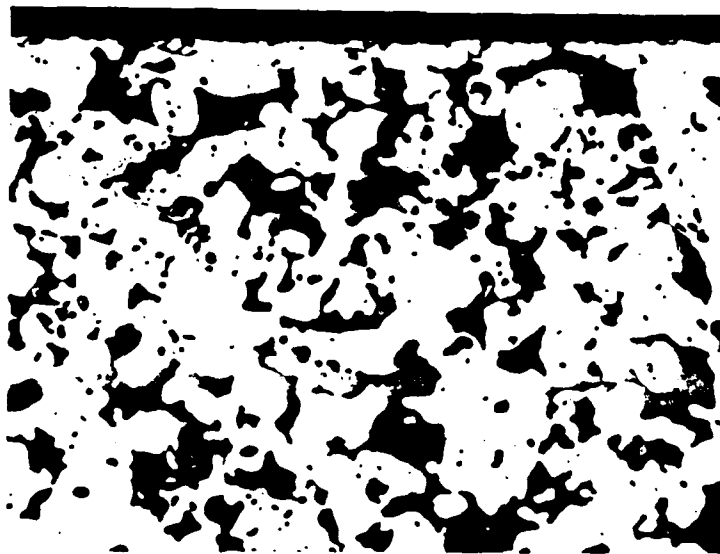

MAG. = 200X

Photo No. 70449

(b)

Figure 31 - CBS1000M P/M rib ring after "break-in" test.

(a) On rib face.

(b) Away from rib face.



Report Documentation Page

1. Report No. NASA CR-180804 AVSCOM TR- 87-C-29		2. Government Accession No.		3. Recipient's Catalog No.	
4. Title and Subtitle IMPROVED OIL-OFF SURVIVABILITY OF TAPERED ROLLER BEARINGS				5. Report Date September 1987	
				6. Performing Organization Code	
7. Author(s) Gary E. Kreider Peter W. Lee				8. Performing Organization Report No.	
				10. Work Unit No. ✓ 1L161102AH45 505-63-51	
9. Performing Organization Name and Address The Timken Company 1835 Dueber Avenue Canton, Ohio 44706				11. Contract or Grant No. NAS3-23689	
				13. Type of Report and Period Covered Final Report 1982-1987	
12. Sponsoring Agency Name and Address U.S. Army Aviation Research and Technology Activity - AVSCOM, Propulsion Directorate, Lewis Research Center, Cleveland, Ohio 44135 and NASA Lewis Research Center, Cleveland, Ohio 44135				14. Sponsoring Agency Code	
				15. Supplementary Notes PROJECT MANAGER: Harold H. Coe, NASA Lewis Research Center, 21000 Brookpark Road, Cleveland, Ohio 44135	
16. Abstract This development program was to improve the oil-off survivability of a tapered roller bearing when applied to a helicopter transmission, since the tapered bearing has shown a performance advantage in this application. However, the critical roller end-rib conjunction is vulnerable to damage in an oil-off condition. Through an initial screening, three powdered metal materials were selected to use as the rib material for oil-off evaluation. These were: M2 steel to a 65% density, CBS 1000M 65% density, and CBS 1000M 75% density. The bearing styles tested were both ribbed cone (inner race) and ribbed cup (outer race). Carburized solid CBS 600 was also used as a ribbed material for comparison of oil-off results. The tests were conducted at six speeds from 4000 rpm (0.26 million DN) through 37000 rpm (2.4 million DN). The ribbed cup style bearing achieved longer lives than the ribbed cone style. A standard bearing lasted only 10 minutes at 4000 rpm; however, the 30 minute oil-off goal was achieved through 11000 rpm using the survivable ribbed cup bearing. The oil-off lives at 37000 rpm were less than 10 seconds. The grinding of the powder metal materials and surface preparation to achieve an open porosity is extremely critical to the oil-off performance of the powder metal component.					
17. Key Words (Suggested by Author(s)) Tapered roller bearing, Ribbed cup, Ribbed cone, Powder metal, Oil-off			18. Distribution Statement UNCLASSIFIED - GENERAL RELEASE STAR Category: 37		
19. Security Classif. (of this report) unclassified		20. Security Classif. (of this page) unclassified		21. No. of pages	22. Price

DATE
FILMED
3 8