

AD-A189 373 THE RELATIONSHIP BETWEEN THE ELLIPSE COMBINATION METHOD 1/1
AND THE PERPENDICULAR METHOD FOR FIXING(U) JET
PROPULSION LAB PASADENA CA 17 DEC 85 JPL-D-4302
UNCLASSIFIED NAS7-918 F/G 17/11 NL

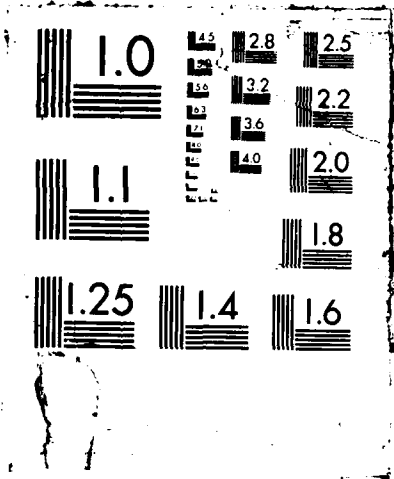



AD-A189 373

7057-78

U.S. ARMY INTELLIGENCE CENTER AND SCHOOL
SOFTWARE ANALYSIS AND MANAGEMENT SYSTEM

THE RELATIONSHIP BETWEEN THE ELLIPSE
COMBINATION METHOD AND THE
PERPENDICULAR METHOD FOR FIXING
TECHNICAL MEMORANDUM No. 14

MARC

Mathematical Analysis Research Corporation

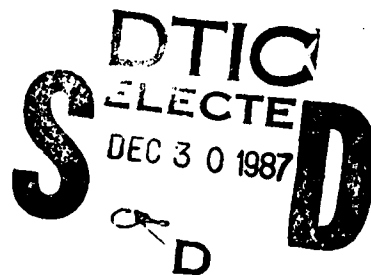
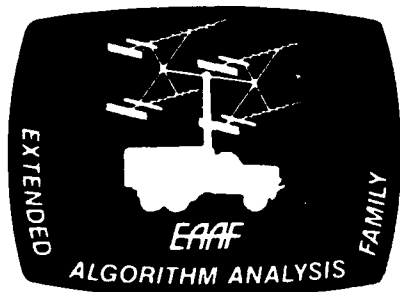

17 December 1985

National Aeronautics and
Space Administration

JPL

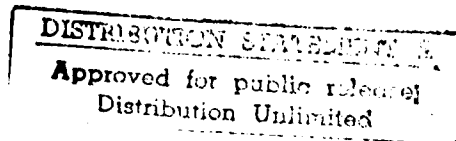

JET PROPULSION LABORATORY
California Institute of Technology
Pasadena, California

JPL D-4302
ALGO_PUB_0028

87 12 21 140

REPORT DOCUMENTATION PAGE		READ INSTRUCTIONS BEFORE COMPLETING FORM
1. REPORT NUMBER ALGO-PUB-0028	2. GOVT ACCESSION NO.	3. RECIPIENT'S CATALOG NUMBER
4. TITLE (and Subtitle) Technical Memo 14, "The Relationship Between the Ellipse Combination Method and the Perpendicular Method for Fixing"		5. TYPE OF REPORT & PERIOD COVERED FINAL
		6. PERFORMING ORG. REPORT NUMBER D-4302
7. AUTHOR(s) Mathematical Analysis Research Corp		8. CONTRACT OR GRANT NUMBER(s) NAS7-918
		10. PROGRAM ELEMENT, PROJECT, TASK AREA & WORK UNIT NUMBERS RE 182 AMEND #187
9. PERFORMING ORGANIZATION NAME AND ADDRESS Jet Propulsion Laboratory ATTN: 171-209 California Institute of Technology 4800 Oak Grove, Pasadena, CA 91109		12. REPORT DATE 17 Dec 85
		13. NUMBER OF PAGES 6
11. CONTROLLING OFFICE NAME AND ADDRESS Commander, USAICS ATTN: ATSI-CD-SF Ft. Huachuca, AZ 85613-7000		15. SECURITY CLASS. (of this report) UNCLASSIFIED
		15a. DECLASSIFICATION/DOWNGRADING SCHEDULE NONE
14. MONITORING AGENCY NAME & ADDRESS (if different from Controlling Office) Jet Propulsion Laboratory, ATTN: 171-209 California Institute of Technology 4800 Oak Grove, Pasadena, CA 91109		
16. DISTRIBUTION STATEMENT (of this Report) Approved for Public Dissemination		
17. DISTRIBUTION STATEMENT (of the abstract entered in Block 20, if different from Report) Prepared by Jet Propulsion Laboratory for the US Army Intelligence Center and School's Combat Developer's Support Facility.		
18. SUPPLEMENTARY NOTES		
19. KEY WORDS (Continue on reverse side if necessary and identify by block number) EEP, Ellipse Combination, Variance, Covariance, Perpendicular Fixing Algorithm, Weighing, Parallel Infinite Strip, Bias, F-Statistic		
20. ABSTRACT (Continue on reverse side if necessary and identify by block number) This memo describes a mathematical equivalence between EEP ellipse combination and LOB combination via the Perpendicular algorithm. This equivalence is then used to transfer the results in Tech Memo 2, "Testing and Combination of Confidence Ellipses: A Geometric Analysis", DTIC #AD-A166581, to results concerning combinations of LOBs for fixing purposes.		

U.S. ARMY INTELLIGENCE CENTER AND SCHOOL
Software Analysis and Management System

The Relationship Between the Ellipse Combination Method
and the Perpendicular Method for Fixing

Technical Memorandum No. 14

17 December 1985

Author:

Michael W. Rennie
MARC
Mathematical Analysis Research Corporation

Approval:

James W. Gillis
James W. Gillis, Subgroup Leader
Algorithm Analysis Subgroup

Edward J. Records
Edward J. Records, Supervisor
USAMS Task

Concur:

A. F. Ellman
A. F. Ellman, Manager
Ground Data Systems Section

Fred Vote
Fred Vote, Manager
Advanced Tactical Systems

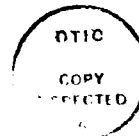

ACCESSION FOR	
NTIS CRASI	<input checked="" type="checkbox"/>
DTIC TAB	<input type="checkbox"/>
Unannounced	<input type="checkbox"/>
Justification	
BY	
DATE	
AUTHORITY	
DISTRIBUTION STATEMENT	
Dist	
A-1	

JET PROPULSION LABORATORY
California Institute of Technology
Pasadena, California

PREFACE

The work described in this publication was performed by the Mathematical Analysis Research Corporation (MARC) under contract to the Jet Propulsion Laboratory, an operating division of the California Institute of Technology. This activity is sponsored by the Jet Propulsion Laboratory under contract NAS7-918, RE182, A187 with the National Aeronautics and Space Administration, for the United States Army Intelligence Center and School.

The Relationship Between the Ellipse Combination Method and the Perpendicular Method for Fixing

INTRODUCTION

Given the proper interpretation the perpendicular method may be thought of as a version of ellipse combination. A number of observations about this relationship will be made in this memo. The sections of this memo correspond to different major points or point of views. To summarize these are:

- 1 I. Geometric interpretation of lines of bearings as ellipses.
- 2 II. Interpretation of EEPs (Error Ellipse Probable) as a geometric combination of lines of bearing in the ellipse format.
- 3 III. Algebraic version of the correspondance between the perpendicular method and ellipse combination.
- 4 IV. Weighted perpendicular versus perpendicular.
- 5 V. Ellipse combination sample size implications with relation to the F statistic.
- 6 VI. The statistical test for acceptance of ellipse combination applied to combination of lines of bearing.

I. GEOMETRIC INTERPRETATION OF LINES OF BEARINGS AS ELLIPSES

To make the connection one must first observe that an ellipse with an infinite radius in one direction would look like two parallel lines (or an infinite strip.) The construction below shows how to construct the strip corresponding to a particular line of bearing (LOB) geometrically.

The first step of ellipse construction consists of drawing the angular confidence region about the LOB (using the chi-square or F cutoff).

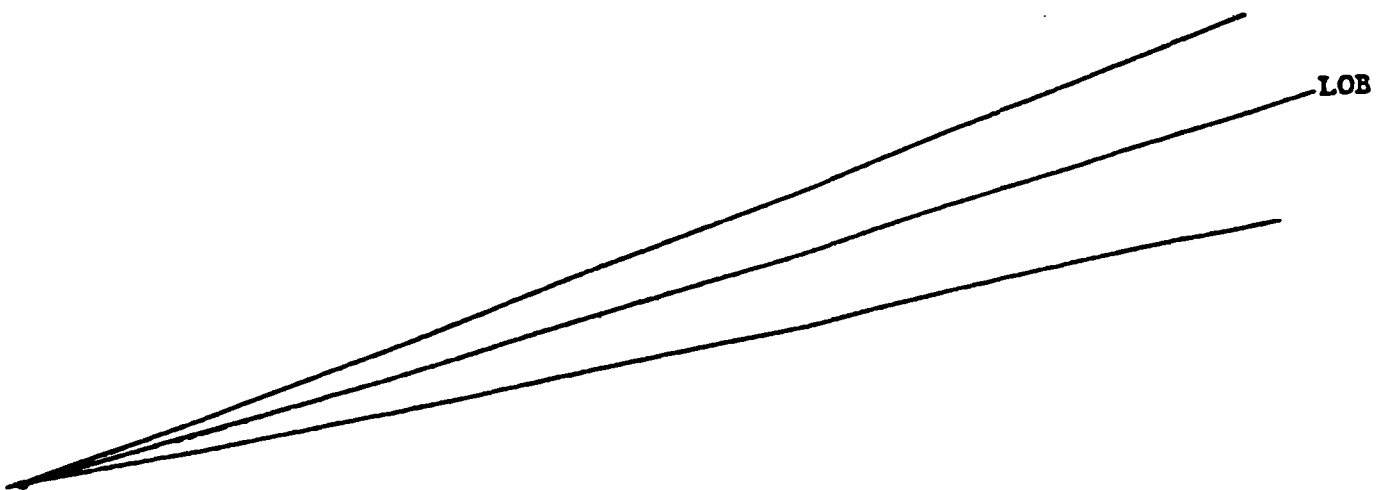

The second step is to go out along the LOB the estimated distance to the emitter and construct a perpendicular. The EEP consists of parallel lines through the points of intersection between this perpendicular and the rays bounding the "true" confidence region constructed in the first step.

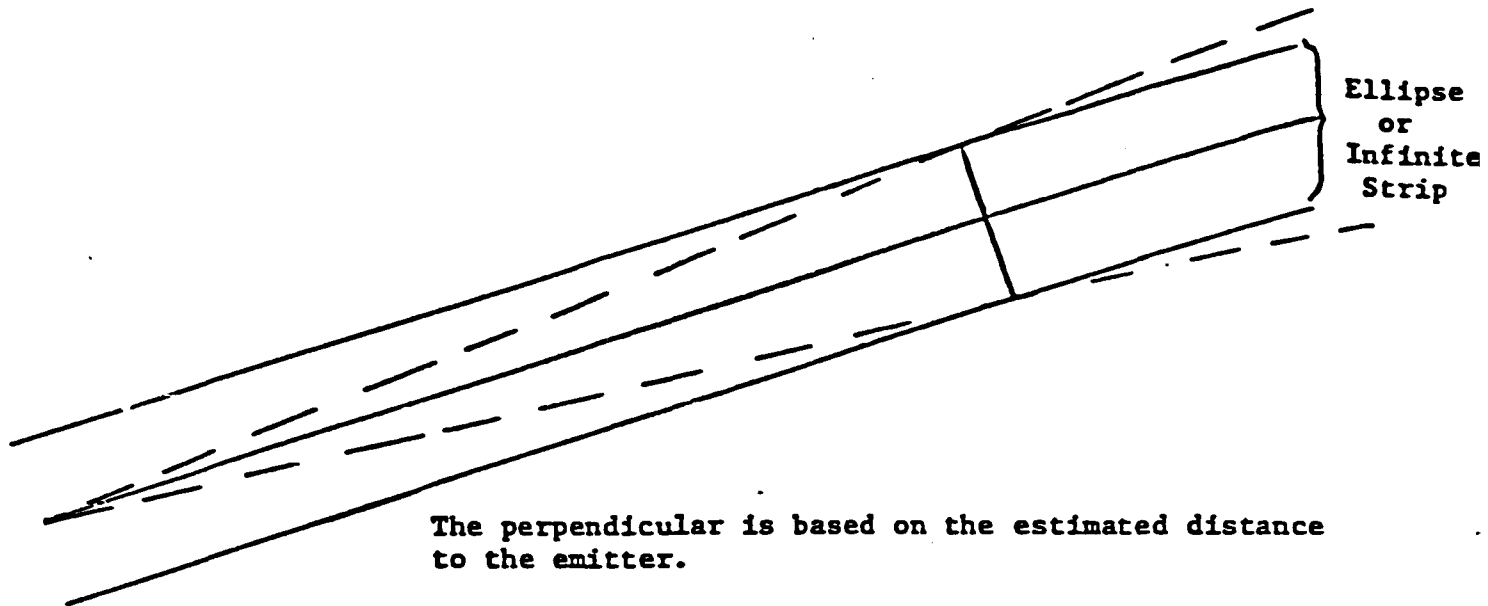

The perpendicular is based on the estimated distance to the emitter.

The estimate of distance to the target is updated periodically. The effect of this is to change the width of the associated infinite ellipse for each LOB. The picture below shows an example of this adjustment.

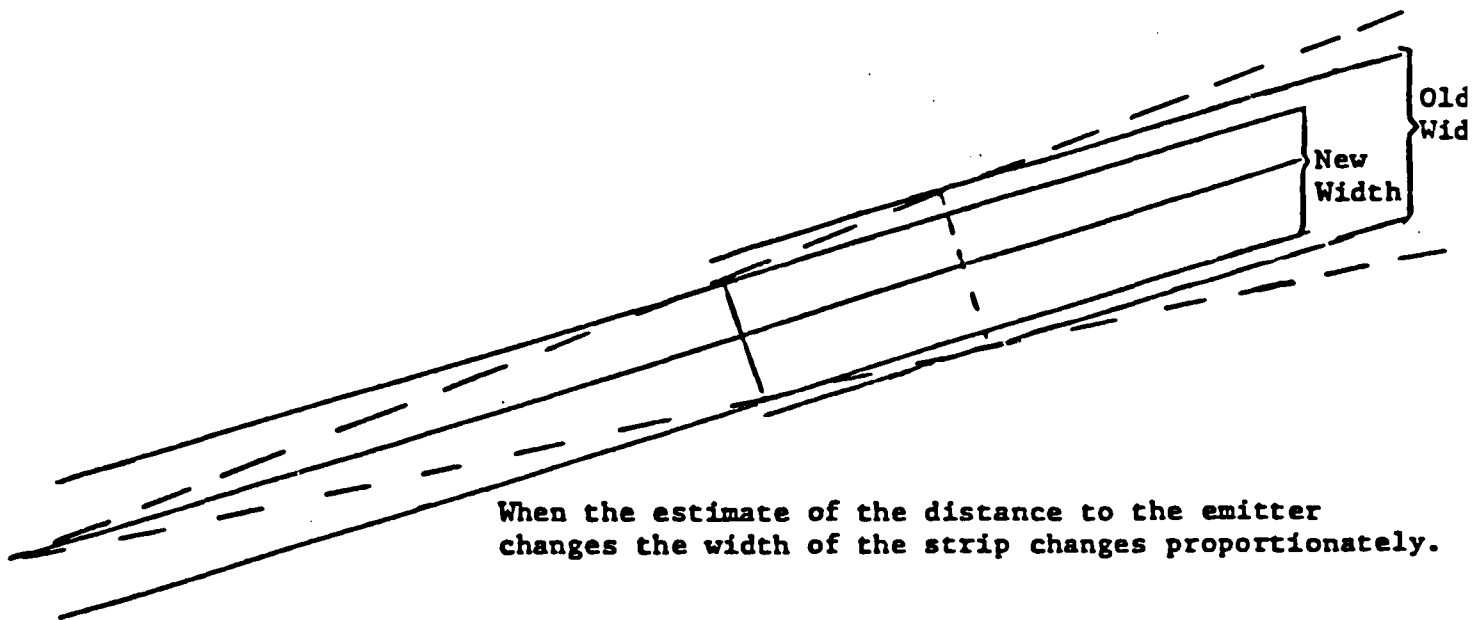

When the estimate of the distance to the emitter changes the width of the strip changes proportionately.

One of the differences between ellipse combination and LOB combination is that for ellipse combination it is no longer possible to update the infinite

ellipse width estimates (as shown in the preceding figure) when the location estimate is updated.

Note that this geometric approach also allows analysis of the accuracy of the weighted perpendicular model to changes in the angular error, cutoff levels, and relative closeness of the target. This analysis can be done by comparing the match of the infinite strip to the infinite "triangular" in the region of interest. (By infinite "triangle" we mean the region shown in the first graph.)

The parallel infinite strip is much different than the infinite triangular region. What really matters, however, is how closely they correspond in the region where the LOBs are intersecting. It is important to update the width of the strip based on the estimate of the distance to the emitter so that the infinite strip corresponds reasonably closely to the appropriate infinite "triangular" region in the neighborhood of the emitter.

Note: Although infinite ellipses have no natural center, for the purposes of ellipse combination it will be necessary to treat these ellipses as if their centers as if they were at the detector (sensor) corresponding to the LOB.

II. EEP'S AS A GEOMETRIC COMBINATION OF LOB'S IN THE ELLIPSE FORMAT

A. Geometric Characterization of the Combination Process

The location and shape determination follows the rules as ellipse combination. A geometric interpretation of these rules may be found in MARC's report TESTING AND COMBINATION OF CONFIDENCE ELLIPSES: A GEOMETRIC APPROACH. A selection of the results reported there are summarized below:

- 1) The size, shape, and orientation of a resultant ellipse is dependent only on the size, shape, and orientation of the original ellipses combined to yield the resultant ellipse. This result is more qualified in the case of LOB based ellipses than ones viewed by the combination algorithm. The size of original ellipses is affected by the location of the estimate in the case of the LOB algorithm.
- 2) When the original point estimates (detector location for single LOB's) are not equal then the resultant ellipse will be approximately positioned upon the intersection of the original ellipses.
- 3) The resultant ellipse after combination would be contained in the intersection of the original ellipses if they were centered at the same point.

B. Infinite Strips vs. Infinite "Triangles"

What gives credibility to the use of infinite strips to approximate the infinite "triangles" is that if the cutoff level is adjusted for the infinite strips the result is close to the same as if the cutoff level for the triangles had been changed instead and then the approximation made. (The actual difference is the difference between x and $\sin(x)$ for small angular spreads, x .) If this were not the case it would not make sense to combine the infinite strips as if they were normal variables. Similar comments apply to some variations on the perpendicular method such as one that passes a finite ellipse through the same points used in the infinite strip construction.

The weakness in these approximations is that the two figures only coincide well near the range where the target is thought to be. Furthermore, the errors are all in the same direction when the LOBs are all taken from one side of the emitter. The affect of compensating for the difference between infinite strips and infinite "triangles" would be shortening and thinning of

EEPs on the detector side of the expected target location and fattening and extension on the other side. In effect this amounts to adding skewness. In some simple cases it should be possible to estimate the amount of skewness added in this way using the ratio of the ellipse width in the "range direction" to the "average range." (Skewness is more likely to affect the acceptance test than the final ellipse shape. Bias is the issue of importance as ellipse size shrinks.)

III. ALGEBRAIC CORRESPONDENCE: ELLIPSE COMBINATION vs. PERPENDICULAR METHOD

A. BASIC DEFINITIONS:

- X denotes the coordinates of an arbitrary point
- X_i denotes the coordinates of a center for the i th ellipse
- $[X_i]$ denotes the set of all centers of the i th ellipse (infinite strips have a line of them, i.e. all points on the LOB)
- Note that $X_i = X$ iff $Q_i(X_i - X) = 0$ (0 vector)
- Z_i denotes the location of the sensor of the i th LOB
- L_i denotes the unit (length=1) vector corresponding to the i th LOB
- S_i denotes the covariance matrix of the i th ellipse
- r_i denotes the estimated distance from the sensor of the i th LOB to the estimated target location. The fact that this value is updated and hence not actually constant shall be critical in what follows.
- Q_i denotes the quadratic form associated with the i th ellipse, in the nondegenerate cases $Q_i = S_i^{-1}$.
- E_i denotes the set of points in the i th ellipse $= \{X | (X - X_i)^T Q_i (X - X_i) \leq k\}$ where k denotes the confidence cut-off value being used.

B. SPACES (This section may be skipped with no loss of continuity)

In what follows it is assumed that the cut-off value, k , is fixed and positive. The centers, X_0 , are allowed to be any point in Euclidean space.

- $\Omega^+ = \{E_i | Q, \text{ the quadratic form, is positive definite}\}$
- $\Omega^0 = \{E_i | Q, \text{ the quadratic form, is nonzero positive}\}$
- $\Omega = \{E_i | \text{any symmetric } Q\}$

Note that Ω is not a manifold. The mapping of

$$\{\text{symmetric } Q\} \times \{\text{centers } X_0\} \text{ -----} \rightarrow \Omega$$

is not 1-1 when Q is singular. Q is singular for LOBs. It turns out that LOB and ellipse combination operations may be defined in (Q, X) representation except when the result is singular, i.e. when parallel LOBs are combined. More precisely there does not exist any extension of the ellipse combination operator that assigns a unique center to the ellipse and which exchanges with limits. (There are extensions that preserve algebraic properties but there is no sense picking a simple topological space if the operator can not be made continuous with respect to it.) Since, however, the only problem is combination of parallel LOBs from different sensors in many cases it will be possible to make application of the (Q, X) representation. If not then the representation made above will have to be used. Note that the Ω representation is a simple modification of the (Q, X) representation made by addition of equivalence classes. In particular,

$$(Q_i, X_i) = (Q_j, X_j) \text{ iff } Q_i = Q_j \text{ and } Q_i(X_i - X_j) = 0$$

Another space of interest is the space of LOBs.

$$\Psi = \{(Z, L, \delta) \mid Z = \text{sensor location, } L = \text{unit vector} = \text{direction, } \delta = \text{angle}\}$$

C. DEFINITION OF THE COMBINATION OPERATOR

First define the operator Θ on the space Ω .

$$Q_i \Theta Q_j = Q_i + Q_j$$

$$[X_i] \Theta [X_j] = \{X \mid (Q_i \Theta Q_j)X = Q_i X_i + Q_j X_j\}$$

In all cases of interest the previous expression becomes

$$= (Q_i \Theta Q_j)^{-1} (Q_i X_i + Q_j X_j)$$

$$E_i \Theta E_j = \{X \mid (X - X_i \Theta X_j)^T Q_i \Theta Q_j (X - X_i \Theta X_j) \leq k\}$$

This definition is independent of the representative of the equivalence class used.

D. FIX ALGORITHMS

$i \phi_1^n(Z_i, L_i, \epsilon_i)$ will mean the output (in Ω) from a fix algorithm (which fix algorithm must be specified in each case)

- (1) The perpendicular method (no weighting)

Note that in most fix applications the weighted version is used.

First identify $Q_i = f(L_i) = L_i^T L_i$ and $X_i = Z_i$ yielding $E_i = g(Z_i, L_i)$

Then define $i \phi_1^n(Z_i, L_i, \epsilon_i) = i \Theta_1^n g(Z_i, L_i)$

- (2) The weighted perpendicular method

$Q_i = f(L_i, r_{ik}, \epsilon_i) = L_i^T L_i / (r_{ik}^2 \sin^2 \epsilon_i)$, $X_i = Z_i$ yielding $E_i = g(Z_i, L_i, r_{ik}, \epsilon_i)$

Then define $i \phi_1^n(Z_i, L_i, \epsilon_i) = \lim_{k \rightarrow \infty} i \Theta_1^n g(Z_i, L_i, r_{ik}, \epsilon_i)$

where r_{ik} = distance from ϵ_i to $i \Theta_1^n g(Z_i, L_i, r_{ik-1}, \epsilon_i)$

i.e. r_{ik} is computed recursively (the recursion is started with an estimate based on fewer LOBs or another source)

In practice it is not necessary to iterate very many times. If r is not updated then one is using ellipse combination.

- (3) Minimization of Angular Square Error

In the sources available to MARC at this time it appears that the shape used is very similar to that used in the weighted perpendicular method. Differences in our source are owing to

- a) differences in the estimate of r owing to any difference in the point estimates
- b) differences between the sin of n standard deviations and n standard deviations itself.

These differences should be relatively minor in comparison with differences in the location of the point estimate.

Comparison of likelihoods to be minimized suggests that both methods (minimization of angular square error and weighted perpendicular) are similar for very accurate observations and that in that case the difference between the two methods being higher order terms in the Taylor Series may reflect the

differences in the way OBSERVED skewness affects the result. Having seen problems already in the perpendicular method's way of handling theoretical skewness suggests that a correction term based on observed skewness might be possible. (Recall that theoretical skewness was characterized above.) Of course by correction we only mean make one method more like the other.

IV. WEIGHTED PERPENDICULAR VERSUS PERPENDICULAR

Through simulation it has been shown that in many cases perpendicular and weighted perpendicular methods produce similar point estimates. The most significant aspect of weighting is that it gives a basis for the shape and size of the EEP. In summary

- a) The perpendicular (without weighting) algorithm is more like ellipse combination than the weighted perpendicular method. This distinction disappears as estimates of the distance to the sensors stabilize. If one waits long enough there is little need to make further updates in these distances as it becomes a very small contributor to the error budget. The hard question for the weighted method is when is this point reached.
- b) The perpendicular (without weighting) algorithm does not use knowledge about the accuracy of the sensor whereas the perpendicular algorithm with weighting does. For this reason it MARC is not surprised that it knows of no systems using the perpendicular method without weights. Computational and storage considerations would suggest that there are probably some systems that compromise between the two, however. In a sense fusion or ellipse combination is such a compromise.
- c) In the geometric examples shown in the beginning of this report the use of the estimated distance from the sensor to the emitter was used but no discussion was made about updating it. Thus the example falls somewhere between the perpendicular method without weighting and the weighted perpendicular method.

VI. SAMPLE SIZE IMPLICATIONS OF THE CORRESPONDENCE

Combining ellipses using small sample sizes can now be seen to raise a number of issues, particularly if F statistics are used. They also suggest some practical methods of dealing with these problems.

- a) If sample sizes are small then it is unclear how stable the estimate of the distance to the point estimate is. EEP's for which ellipse size is a large percentage of the distance to where the observations were taken should be tracked longer individually before fusion (ellipse combination).
- b) If ellipse size is based on the F statistic, the weighted perpendicular method and a small sample size then one would appear to be using that data pessimistically in ellipse combination. Fusion (ellipse combination) appears to be a natural continuation of the perpendicular method. This comment does not apply to the acceptance test. Whether or not this comment applies in cases where the original ellipse was not based on the perpendicular method will have to be studied further.
- c) The bias associated with the perpendicular method is perpetuated by the ellipse combination. Bias being a function of sample size for a given baseline may have implications for ellipse combination.

VI. STATISTICAL TESTS

Since ellipse combination and the perpendicular method are similar it seems reasonable to propose comparison of these tests.

END
DATE

FILMED

MARCH

1988

DTIC