

6-2

DOC_NUM	SER	CN
UNC28883-PDC	A	1



**FORCE AND MOMENT TESTS TO DETERMINE THE INTERACTION  
EFFECTS OF THE REACTION CONTROL SYSTEM JET PLUMES  
ON THE SPACE SHUTTLE ORBITER AERODYNAMICS  
AT MACH NUMBER 6 (TEST OA352)**



**Robert W. Cayse**  
Calspan Corporation/AEDC Division

November 1987

Final Report for Period January 20 - February 6, 1987

Approved for public release; distribution is unlimited.

**ARNOLD ENGINEERING DEVELOPMENT CENTER  
ARNOLD AIR FORCE BASE, TENNESSEE  
AIR FORCE SYSTEMS COMMAND  
UNITED STATES AIR FORCE**

**TECHNICAL REPORTS  
FILE COPY**

PROPERTY OF U.S. AIR FORCE  
AEDC TECHNICAL LIBRARY

UNCLASSIFIED

## NOTICES

When U. S. Government drawings, specifications, or other data are used for any purpose other than a definitely related Government procurement operation, the Government thereby incurs no responsibility nor any obligation whatsoever, and the fact that the Government may have formulated, furnished, or in any way supplied the said drawings, specifications, or other data, is not to be regarded by implication or otherwise, or in any manner licensing the holder or any other person or corporation, or conveying any rights or permission to manufacture, use, or sell any patented invention that may in any way be related thereto.

References to named commercial products in this report are not to be considered in any sense as an endorsement of the product by the United States Air Force or the Government.

## DESTRUCTION NOTICE

For classified documents, follow the procedures in DoD 5200.22-M, Industrial Security Manual, Section II-19 or DoD 5200.1-R, Information Security Program Regulation, Chapter IX. For unclassified, limited documents, destroy by any method that will prevent disclosure or reconstruction of the document.

## APPROVAL STATEMENT

This report has been reviewed and approved.

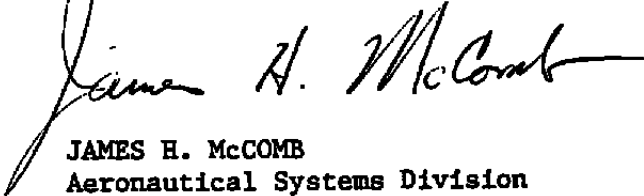

JAMES H. McCOMB  
Aeronautical Systems Division  
Directorate of Aerosp Flt Dyn Test  
Deputy for Operations

Approved for publication:

FOR THE COMMANDER



ELTON R. THOMPSON  
Dir, Aerospace Flt Dyn Test  
Deputy for Operations

UNCLASSIFIED

SECURITY CLASSIFICATION OF THIS PAGE

REPORT DOCUMENTATION PAGE				Form Approved OMB No. 0704-0188	
1a. REPORT SECURITY CLASSIFICATION <b>UNCLASSIFIED</b>		1b. RESTRICTIVE MARKINGS			
2a. SECURITY CLASSIFICATION AUTHORITY		3. DISTRIBUTION/AVAILABILITY OF REPORT			
2b. DECLASSIFICATION/DOWNGRADING SCHEDULE		Approved for public release; distribution unlimited.			
4. PERFORMING ORGANIZATION REPORT NUMBER(S) <b>AEDC-TSR-87-V5</b>		5. MONITORING ORGANIZATION REPORT NUMBER(S)			
6a. NAME OF PERFORMING ORGANIZATION <b>Arnold Engineering Development Center</b>		6b. OFFICE SYMBOL (if applicable) <b>DOF</b>		7a. NAME OF MONITORING ORGANIZATION	
6c. ADDRESS (City, State, and ZIP Code) <b>Air Force Systems Command Arnold Air Force Base, Tennessee 37389-5000</b>		7b. ADDRESS (City, State, and ZIP Code)			
8a. NAME OF FUNDING/SPONSORING ORGANIZATION <b>NASA/JSC</b>		8b. OFFICE SYMBOL (if applicable)		9. PROCUREMENT INSTRUMENT IDENTIFICATION NUMBER	
8c. ADDRESS (City, State, and ZIP Code) <b>ED 3 Houston, Texas 77058</b>		10. SOURCE OF FUNDING NUMBERS			
		PROGRAM ELEMENT NO. <b>921E01</b>	PROJECT NO.	TASK NO.	WORK UNIT ACCESSION NO.
11. TITLE (Include Security Classification) <b>Force and Moment Tests to Determine the Interaction Effects of the Reaction Control System Jet Plumes on the Space Shuttle Orbiter Aerodynamics at Mach Number 6 (Test OA352).</b>					
12. PERSONAL AUTHOR(S) <b>Cayse, Robert W., Calspan Corporation, AEDC Division</b>					
13a. TYPE OF REPORT <b>Final</b>		13b. TIME COVERED <b>FROM 1/20/87 TO 2/6/87</b>		14. DATE OF REPORT (Year, Month, Day) <b>November 1987</b>	
15. PAGE COUNT <b>51</b>					
16. SUPPLEMENTARY NOTATION <b>Available in Defense Technical Information Center (DTIC).</b>					
17. COSATI CODES			18. SUBJECT TERMS (Continue on reverse if necessary and identify by block number)		
FIELD	GROUP	SUB-GROUP	space shuttle orbiter wind tunnel testing		
<b>01</b>	<b>02</b>		reaction control system		
			aerodynamic interference		
19. ABSTRACT (Continue on reverse if necessary and identify by block number) <p>The purpose of this test was to expand the existing Space Shuttle aerodynamics and reaction control system (RCS) data base to support the Glide Return to Launch Site (GRTLs) abort trajectory and the new Digital Autopilot. An existing model of the orbiter was used to investigate the aerodynamic effects of several combinations of RCS thrusters and thruster momentum ratios at Mach number 6. Two separate model installations were used to achieve an angle-of-attack range of -11 to 46 deg. The test was conducted at a unit Reynolds number of <math>0.8 \times 10^6</math> per foot.</p>					
20. DISTRIBUTION/AVAILABILITY OF ABSTRACT <input checked="" type="checkbox"/> UNCLASSIFIED/UNLIMITED <input type="checkbox"/> SAME AS RPT. <input type="checkbox"/> DTIC USERS			21. ABSTRACT SECURITY CLASSIFICATION <b>UNCLASSIFIED</b>		
22a. NAME OF RESPONSIBLE INDIVIDUAL <b>C. L. Garner</b>			22b. TELEPHONE (Include Area Code) <b>(615) 454-7813</b>		22c. OFFICE SYMBOL <b>DOCS</b>

## CONTENTS

	<u>Page</u>
NOMENCLATURE. . . . .	2
1.0 INTRODUCTION. . . . .	6
2.0 APPARATUS	
2.1 Test Facility. . . . .	6
2.2 Test Article . . . . .	6
2.3 Test Instrumentation . . . . .	7
3.0 TEST DESCRIPTION	
3.1 Test Conditions. . . . .	8
3.2 Test Procedures. . . . .	8
3.3 Data Reduction . . . . .	9
3.4 Measurement Uncertainties. . . . .	13
4.0 DATA PACKAGE PRESENTATION . . . . .	13
REFERENCES. . . . .	14

## ILLUSTRATIONS

### Figure

1. Tunnel B. . . . .	15
2. Shuttle Orbiter 1.25% Scale Model . . . . .	16
3. Typical Model Installation. . . . .	17
4. Location of RCS Jets. . . . .	20

## TABLES

### Table

1. RCS Configurations. . . . .	22
2. Estimated Uncertainties . . . . .	26
3. Test Run Summary. . . . .	28

## SAMPLE DATA

### Sample

1. Tabulated Force and Moment Data . . . . .	33
2. Tabulated Interference Data . . . . .	37
3. Plotted Force and Moment Data . . . . .	38
4. Plotted Interference Data . . . . .	43

## NOMENCLATURE

A	Throat area of venturi flow meter, in. <sup>2</sup>
AE	Nominal RCS jet exit area, 0.014698 in. <sup>2</sup>
ALPHA	Angle of attack in body axes, deg
ALPI	Indicated sector pitch angle, deg
CD	Venturi flow meter discharge coefficient
CE1, 2	Hot film flow meter calibration factors
CLL	Rolling moment coefficient including thrust
CLLR	Rolling moment coefficient without thrust
CLM	Pitching moment coefficient including thrust
CLMR	Pitching moment coefficient without thrust
CLN	Yawing moment coefficient including thrust
CLNR	Yawing moment coefficient without thrust
CONFIG	RCS jet configuration
CN	Normal force coefficient including thrust
CNR	Normal force coefficient without thrust
CY	Side force coefficient including thrust
CYR	Side force coefficient without thrust
DCLLR	See Section 3.3.1
DCLMR	See Section 3.3.1
DCLNR	See Section 3.3.1
DCNR	See Section 3.3.1
DCYR	See Section 3.3.1
DNV	Venturi flow meter throat diameter, in.
DPV1	Venturi system differential pressure, (supply total pressure - throat static pressure), psid
EFILM	Voltage reading of hot film mass flow system, volts

ELEVON	Elevon angle, positive trailing edge down, deg
EZERO	Voltage reading of hot film mass flow system with zero flow, volts
K1, 2	Calibration constants for model chamber pressures PC1, 2
KM1, 2	Rockwell-supplied mass flow calibration factor for forward and aft RCS jets, respectively, lbm/(sec-OR0.5-psia)
KT1	RCS thrust tare calibration factor for normal force, lbf/psia
KT2	RCS thrust tare calibration factor for pitching moment, in.-lbf/psia
KT3	RCS thrust tare calibration factor for side force, lbf/psia
KT4	RCS thrust tare calibration factor for yawing moment, in.-lbf/psia
KT5	RCS thrust tare calibration factor for rolling moment, in.-lbf/psia
KTHALS	Rockwell-supplied RCS group thrust calibration factor for aft left side, lbf/psia
KTHARS	Rockwell-supplied RCS group thrust calibration factor for aft right side, lbf/psia
KTHFLS	Rockwell-supplied RCS group thrust calibration factor for forward left side, lbf/psia
KTHFRS	Rockwell-supplied RCS group thrust calibration factor for forward right side, lbf/psia
L1, 2, 3	Reference lengths for pitching, yawing, and rolling moments respectively, 5.935, 11.709, 11.709 in.
M	Free-stream Mach number
MDOT	Auxiliary air flow rate, lbm/sec
MDOTP	Intermediate mass flow calculation, lbm/sec
MU	Dynamic viscosity at venturi flow meter, lbf-sec/ft <sup>2</sup>
N	Total number of active RCS jets

NALS	Number of RCS jets for aft left group
NARS	Number of RCS jets for aft right group
NFLS	Number of RCS jets for forward left group
NFRS	Number of RCS jets for forward right group
P	Free-stream static pressure, psia
P2PA	Intermediate mass flow parameter
PC1,2	Calculated model chamber pressures, psia
PC1A, 2A	Measured model chamber pressures, psia
PFILM	Total pressure at hot film flow meter, psia
PHI	Model roll angle, deg
PHII	Indicated sector roll angle, deg
PHIM	Intermediate term for venturi mass flow calculation
PS1	Sting air supply line static pressure, psia
PS2	Pressure at flow meter, psia
PT	Free-stream total pressure, psia
PTS	Sting air supply line total pressure, psia
PTV1	Auxiliary air total pressure upstream of venturi flow meter, psia
Q	Free-stream dynamic pressure, psia
RE	Free-stream unit Reynolds number, ft <sup>-1</sup>
RED	Reynolds number at venturi flow meter based on throat diameter
S	Reference area, 60.525 in. <sup>2</sup>
T	Free-stream static temperature, °R
TC	Calculated temperature in model air supply chambers, °R
TFILM	Total temperature at hot film flow meter, °R
TFM	Auxiliary air total temperature at either venturi or hot film flow meter, °R

TTV1            Auxiliary air total temperature upstream of venturi  
                 flow meter, OR

V                Free-stream velocity, ft/sec

WG              Auxiliary air flow rate calculated using Rockwell-  
                 supplied discharge coefficients, lbm/sec

## 1.0 INTRODUCTION

The work reported herein was performed by the Arnold Engineering Development Center (AEDC), Air Force Systems Command (AFSC) under Program Element 921E01, Control Number 9E01, at the request of NASA Johnson Space Center, Houston, Texas. The NASA project manager was Mr. O. B. Kanipe, and the Rockwell International representative was Mr. J. G. R. Collette. The DOFA project manager was Captain K. Gibby. The results were obtained by Calspan Corporation/AEDC Division, operating contractor of the Aerospace Flight Dynamics testing effort at the AEDC, AFSC, Arnold Air Force Base, Tennessee. The test was performed in the von Karman Gas Dynamics Facility (VKF), Hypersonic Wind Tunnel B, during the period of January 20 through February 6, 1987, under AEDC Project Number CH07VB (Calspan Number V41B-27).

The purpose of this test was to expand the existing Space Shuttle aerodynamics and reaction control system (RCS) data base to support the Glide Return to Launch Site (GRTLS) abort trajectory and the new Digital Autopilot. An existing model of the orbiter was used to investigate the aerodynamic effects of several combinations of RCS thrusters and thruster momentum ratios at Mach number 6. Two separate model installations were used to achieve an angle-of-attack range of -11 to 46 deg. The test was conducted at a unit Reynolds number of  $0.8 \times 10^6$  per foot.

Inquiries to obtain copies of the test data should be directed to NASA/JSC, ED 3, Houston, TX 77058. A microfiche record has been retained at the AEDC.

## 2.0 APPARATUS

### 2.1 TEST FACILITY

The von Karman Gas Dynamics Facility Hypersonic Wind Tunnel B (Fig. 1) is a closed circuit hypersonic wind tunnel with a 50-in.-diam test section. Two axisymmetric contoured nozzles are available to provide Mach numbers of 6 and 8, and the tunnel may be operated continuously over a range of pressure levels from 20 to 300 psia at Mach number 6, and 50 to 900 psia at Mach number 8, with air supplied by the VKF main compressor plant. Stagnation temperatures sufficient to avoid air liquefaction in the test section (up to 1350 OR) are obtained through the use of a natural-gas-fired combustion heater. The entire tunnel (throat, nozzle, test section, and diffuser) is cooled by integral, external water jackets. The tunnel is equipped with a model injection system which allows removal of the model from the test section while the tunnel remains in operation. A description of the tunnel may be found in Ref. 1.

### 2.2 TEST ARTICLE

Model 70-02, a 1.25-percent scale model of the Space Shuttle Orbiter Vehicle 102, was supplied by Rockwell International and was

constructed of 17-4 PH stainless steel (Figs. 2 and 3). Elevation settings of 0, +20, and -20 deg were provided by interchangeable brackets.

Thirty-four RCS thrusters were simulated on the model, of which eight were inactive. Of the twenty-six active thrusters, eight were on the nose and nine were on each of the Orbital Maneuvering System (OMS) pods (Fig. 4). The model RCS system was composed of three removable nozzle blocks, one for each of the two OMS pods and one for the nose. Each thruster could be operated separately or in combination with any of the other thrusters by removing plugs from specific holes in the nozzle blocks. Table 1 shows the combinations of RCS thrusters tested.

All thrusters in a nozzle block were fed from a common chamber. The chamber for each block was connected to the Auxiliary Mass Flow System through the model support sting and load balance. Chamber pressures in both the aft and forward nozzle blocks could be measured, as well as the static and pitot pressure in the sting air supply line.

## 2.3 TEST INSTRUMENTATION

The instrumentation, recording devices, and calibration methods used for all measured parameters are listed in Table 2. In Tunnel B, stilling chamber pressure is measured with a 200- or 1000-psid transducer referenced to a near vacuum; the stilling chamber temperature is measured with Chromel-Alumel

thermocouples.

### 2.3.1 Pressure and Mass Flow Instrumentation

Pressures in the sting air supply line were measured with two 2000-psi Setra pressure transducers calibrated for the range of 200 to 1200 psia. During the jet-calibration phase of the test, pressures in the model air-supply chambers were measured with two additional 2000-psi Setra transducers calibrated for the same range. The Tunnel B Standard Pressure System (SPS) was used to measure the ambient pressure on the model during the jet calibrations. The SPS uses 15-psid transducers with ranges of 0.15, 1.5, and 15 psia and is referenced to near vacuum.

The auxiliary mass flow system was used to supply air to the model during jet calibrations and tests. The supply air was metered through a long-radius venturi package for flow rates above 0.05 lbm/sec or for air supply pressures greater than 900 psia. A hot film anemometer package was used for lower flow rates and pressures.

### 2.3.2 Model Force Instrumentation

Model forces and moments were measured with a five-component, flow-through, strain gage balance (designated SS05) which was supplied by NASA Langley Research Center and was calibrated by AEDC. Prior to the test, static loads in each plane and combined loads were applied to the balance to simulate the range of loads and center-of-pressure

locations anticipated for the test. This simulated loading was performed with an internal balance air pressure of 1100 psia.

### 2.3.3 Optical

Model flow-field shadowgraph photographs were obtained during the test on all configurations at selected model attitudes. The photographs were obtained with a single-pass optical flow-visualization system through two 17.25-in.-diam test section windows.

## 3.0 TEST DESCRIPTION

### 3.1 TEST CONDITIONS

The nominal test condition for the test is given below:

<u>M</u>	<u>PT, psia</u>	<u>TT, OR</u>	<u>Q, psia</u>	<u>P, psia</u>	<u>RE, 10<sup>6</sup>/ft</u>	<u>V, ft/sec</u>	<u>T, OR</u>
5.96	40.4	850	0.66	0.027	0.76	2992	105

A test summary showing all configurations tested is presented in Table 3.

### 3.2 TEST PROCEDURES

#### 3.2.1 General

In the continuous flow Wind Tunnel B, the model is mounted on a sting support mechanism in an installation tank directly underneath the tunnel test section. The tank is separated from the tunnel by a pair of fairing doors and a safety door. When closed, the fairing doors, except for a slot for the pitch sector, cover the opening to the tank, and the safety door seals the tunnel from the tank area. After the model is prepared for a data run, the personnel access door to the installation tank is closed, the tank is vented to the tunnel flow, the safety and fairing doors are opened, the model is injected into the airstream, and the fairing doors are closed. After the data are obtained, the sequence is reversed; the model is retracted into the tank, and the tank is vented to atmosphere to allow access to the model in preparation for the next run. The sequence is repeated for each configuration change.

#### 3.2.2 Data Acquisition

Model attitude positioning and data recording were accomplished with the point-pause and continuous sweep modes of operation, using the VKF Model Attitude Control System (MACS). Model pitch and roll requirements were entered into the controlling computer prior to the test. Model positioning and data recording operations were performed automatically during the test by selecting the list of desired model attitudes and initiating the system.

Point-pause data were obtained for selected values of ALPHA and BETA after a 1.0 sec delay for stabilization. Continuous sweep data were obtained with a pitch rate of 1.0 deg/sec. A data sample was recorded every 0.0208 sec and 16 samples were applied to a sliding Kaiser-Bessel digital filter to produce a point every 0.3 deg in pitch. The data were then interpolated to obtain data at the requested model attitudes.

Generally, after a model jet configuration was set, the model was injected into the tunnel flow, and a run at zero mass flow rate was made. This zero-flow-rate run served to demonstrate repeatable operation of the force balance and was later used for computing the difference between jet-on and jet-off (i.e. interference) force data. After the zero-flow-rate run was completed, the model remained in the tunnel test section, a mass flow rate was set, and data were obtained. This process was repeated for all desired flow rates for the specific configuration.

Prior to the force testing phase, a calibration was made to correlate PC1A and PC2A (the model air supply chamber pressures) with PTS (the pitot pressure in the sting air supply line) for several RCS jet configurations. These data were extrapolated to obtain correlations for the remaining jet configurations. The PC1A and PC2A pressure tubes were then disconnected from the model to eliminate interference with the force balance.

After the calibration of PC1A and PC2A, a thrust calibration was performed. This was accomplished by reducing the pressure in the model installation tank to approximately 0.5 psia and obtaining force data at several mass flow rates. The reduced tank pressure was required to ensure that the flow from each RCS jet was fully expanded. To eliminate jet impingement, a sting-mounted shield was placed at the aft end of the model, and the model wing and body flap were removed. This calibration resulted in a correlation of the thrust for each of the five balance components with PTS. A thrust calibration was performed for each of the RCS configurations.

### 3.3 DATA REDUCTION

#### 3.3.1 Forces and Moments

Static force data obtained utilizing the tunnel data acquisition system described in Section 3.2 were reduced to coefficient form using the digitally filtered data points and corrected for first- and second-order balance interaction effects and for the RCS air supply pressure in the balance. The aerodynamic coefficients were corrected for model tare weight and balance-sting deflections. Model attitude and tunnel stilling chamber pressure were also calculated from digitally filtered values.

Model aerodynamic force and moment coefficients are presented in the body axis system. The reference area was the model planform of 60.525 in.<sup>2</sup>. Moment coefficients are referenced to a point corresponding to the orbiter center of gravity at 65 percent of the body length (Fig. 2). The mean cord, 5.935 in., was used to normalize pitching moment, and the span, 11.709 in., was used in normalizing yawing and rolling moment.

The body axes coefficients were corrected for thrust effects using the following equations:

$$CNR = CN - KT1*PTS/(Q*S)$$

$$CLMR = CLM - KT2*PTS/(Q*S*L1)$$

$$CYR = CY - KT3*PTS/(Q*S)$$

$$CLNR = CLN - KT4*PTS/(Q*S*L2)$$

$$CLLR = CLL - KT5*PTS/(Q*S*L3)$$

where KT1-5 were determined during the thrust calibration described in Section 3.2.2 and are listed in Table 1d.

The interference effects coefficients were calculated using the equations:

$$DCNR = CNR_{jet-on run} - CNR_{jet-off run}$$

$$DCLMR = CLMR_{jet-on run} - CLMR_{jet-off run}$$

$$DCYR = CYR_{jet-on run} - CYR_{jet-off run}$$

$$DCLNR = CLNR_{jet-on run} - CLNR_{jet-off run}$$

$$DCLLR = CLLR_{jet-on run} - CLLR_{jet-off run}$$

### 3.3.2 Pressures

The sting pressures, PTS and PS1, were measured parameters. For the calibration, the model chamber pressures, PC1A and PC2A, were also measured. For the remainder of the test, the model chamber pressures were calculated using the calibration constants, i.e.:

$$PC1 = K1 * PTS$$

$$PC2 = K2 * PTS$$

where K1 and K2 are given for each configuration in Table 1c.

For the calculation of TC (described below in Section 3.3.3), a "flow meter pressure," PS2, was used. For runs using the hot film flow meter, PS2 was set equal to PFILM, and set equal to PTV1 for runs using the venturi flow meter. Standard data reduction methods were used to calculate PFILM, DPV1, and PTV1.

### 3.3.3 Temperature

TFILM and TTV1 were measured parameters. For the WG calculation of Section 3.3.4, a model chamber temperature was calculated. This was accomplished by applying the Joule-Thompson throttling correction to the flow meter temperature which gives the equation

$$TC = TFM - 0.0279*(PS2 - PTS)$$

where TFM was set equal to TFILM for runs using the hot film flow meter, and set equal to TTV1 for runs using the venturi flow meter.

### 3.3.4 Flow Rates

The data reduction equations used for the hot film are

$$MDOTP = CE1*(EFILM2 - EZERO2)CE2$$

$$MDOT = [(TFILM/530)^{1.5} * 728.6 / (TFILM + 198.6)] * MDOTP$$

where the term in brackets is a viscosity correction.

The equations used for the venturi flow rate data reduction are

$$P2PA = 1.0 - DPV1/PTV1$$

$$PHIM = ((P2PA^{1.4286}/0.28571) * (1.0 - P2PA^{0.28571}) / (1.0 - 0.000397 * P2PA^{1.4286}))^{0.5}$$

$$MDOTP = 1.09822 * PHIM * PTV1 * A / TTV^{10.5}$$

$$MU = 2.89 * 10^{-9} * TTV^{10.7778}$$

$$RED = 0.474883 * MDOTP / MU / DNV$$

$$CD = 1.0 - 2.03 / RED^{0.44}$$

$$MDOT = CD * MDOTP$$

A secondary flow rate calculation was made using discharge coefficients provided by Rockwell, which resulted in the equation

$$WG = (KM1*PC1 + KM2*PC2)/TC0.5$$

The values of KM1 and KM2 used for each RCS configuration are given in Table 1c.

### 3.3.5 Thrusts and Momentum Ratios

Four groups of jets were designated for the RCS system: FLS, forward left side; FRS, forward right side; ALS, aft left side; and ARS, aft right side. For each group, theoretical and "actual" thrusts and momentum ratios were calculated. The theoretical thrusts were calculated using the nominal RCS jet geometry which resulted in the equation

$$T_{xxxT} = N_{xxx}*(0.0019554*PC_x - 0.0147*P)$$

where xxx designates the jet group and PCx was PC1 for the forward groups and PC2 for the aft groups.

The "actual" thrusts were computed using discharge coefficients provided by Rockwell. The resulting equation was

$$T_{xxxA} = KTH_{xxx}*PC_x - xxx*P*AE$$

with the same conventions previously used for PCx and xxx. The KTHxxx values used for each configuration are given in Table 1c.

In the same manner as for the theoretical thrusts, the theoretical momentum ratios were determined using the nominal jet geometry. This resulted in the equation

$$MR_{xxxT} = 0.0022345*N_{xxx}*PC_x/Q$$

The "actual" momentum ratio for each group was then determined using the equation

$$MR_{xxxA} = T_{xxxA}*MR_{xxxT}/N_{xxx}/T_{xxxT}$$

An overall momentum ratio was calculated using only the thrust groups on the left side of the model, resulting in the equation

$$MR = (N_{FLS}*MR_{FLSA} + N_{ALS}*MR_{ALSA})/(N_{FLS} + N_{ALS})$$

### 3.4 MEASUREMENT UNCERTAINTIES

In general, instrumentation calibrations and data uncertainty measurements were made using methods recognized by the National Bureau of Standards (NBS), (Ref. 2). Measurement uncertainty (U) is a combination of bias and precision errors defined as:

$$U = \pm (B + t_{95}S)$$

where B is bias limit, S is the sample standard deviation, and  $t_{95}$  is the 95th percentile point for the two-tailed Student's "t" distribution, which equals approximately 2 for degrees of freedom greater than 30.

Estimates of the measured data uncertainties for this test are given in Tables 2a and b. In general, measurement uncertainties are determined from in-place calibrations through the data recording system and data reduction program.

The propagation of the estimated bias and precision errors of the measured data through the data reduction was determined for free-stream parameters in accordance with Ref. 2, and is summarized in Table 2b.

### 4.0 DATA PACKAGE PRESENTATION

Force and moment data, mass flow data, and test conditions were reduced to tabular and graphical form for presentation as a Data Package. Examples of the basic data tabulations and plots are shown in the Sample Data. All photographic data, including model installation and shadowgraph photographs, were sent to the sponsor and user under separate cover.

## REFERENCES

1. Test Facilities Handbook (Twelfth Edition), "von Karman Gas Dynamics Facility, Vol. 3," Arnold Engineering Development Center, March 1984.
2. Abernethy, R. B. et. al. and Thompson, J. W. "Handbook Uncertainty in Gas Turbine Measurements," AEDC-TR-73-5 (AD755356), February 1973.

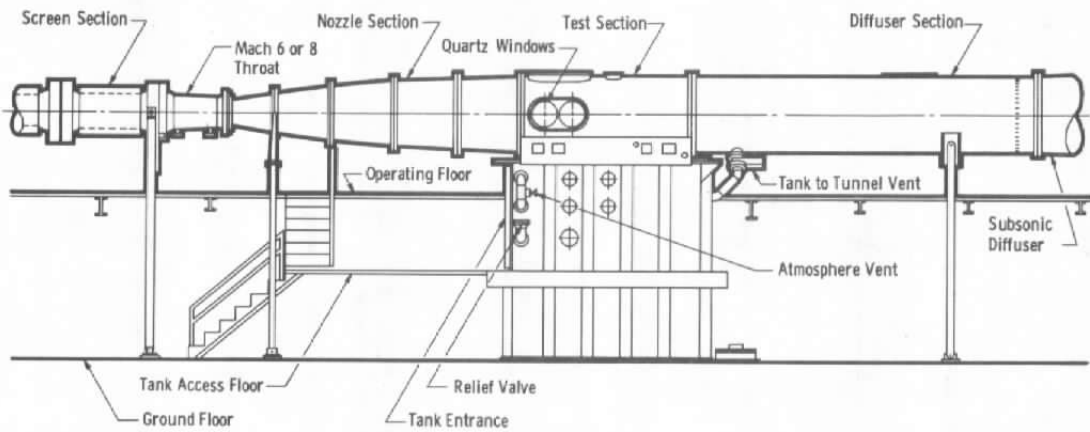

**a. Tunnel assembly**

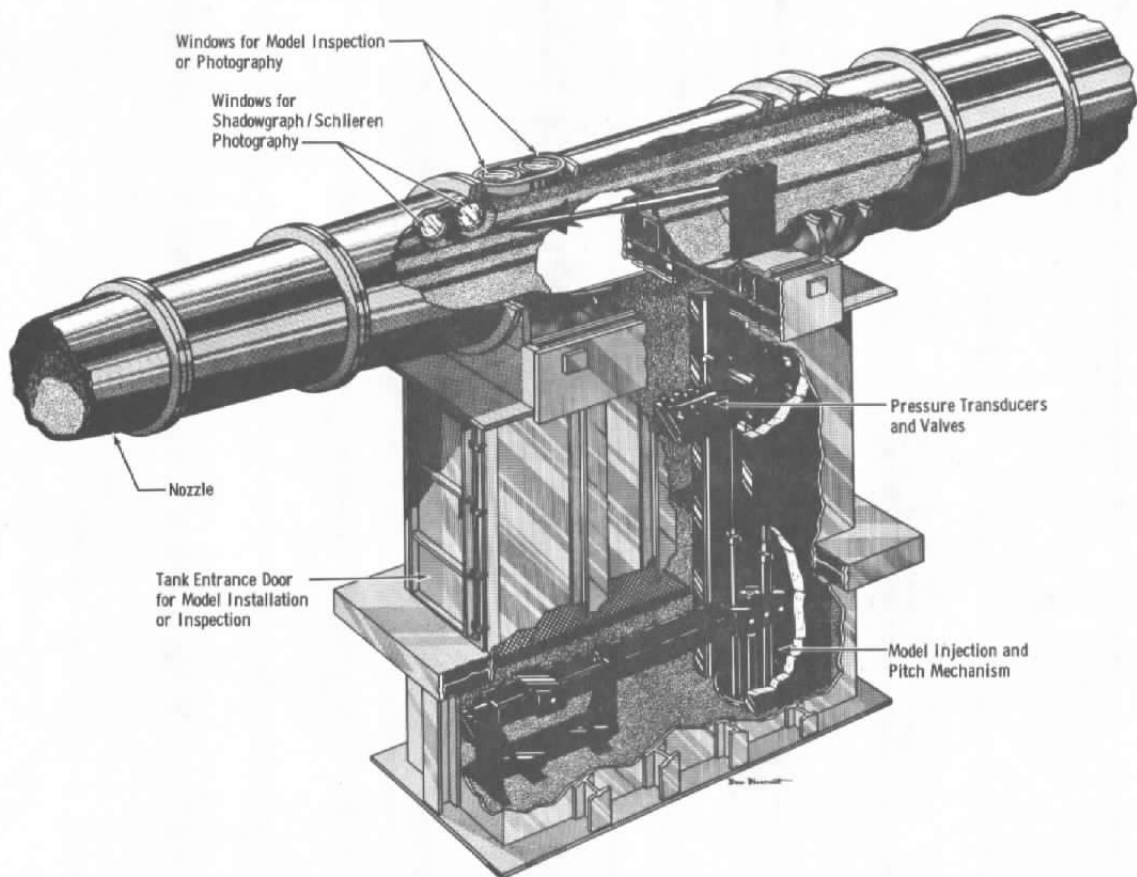

**b. Tunnel test section**  
**Fig. 1. Tunnel B**

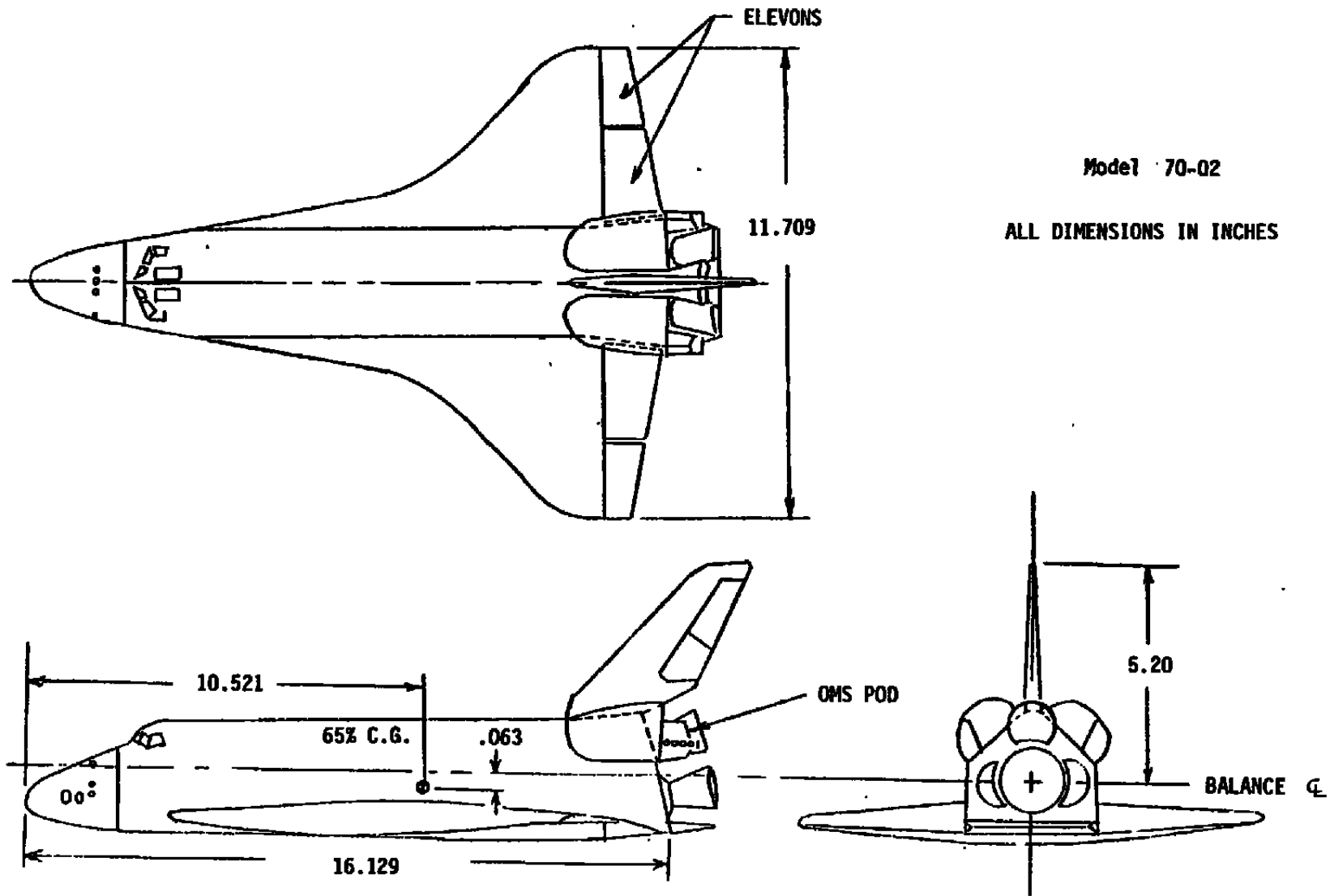
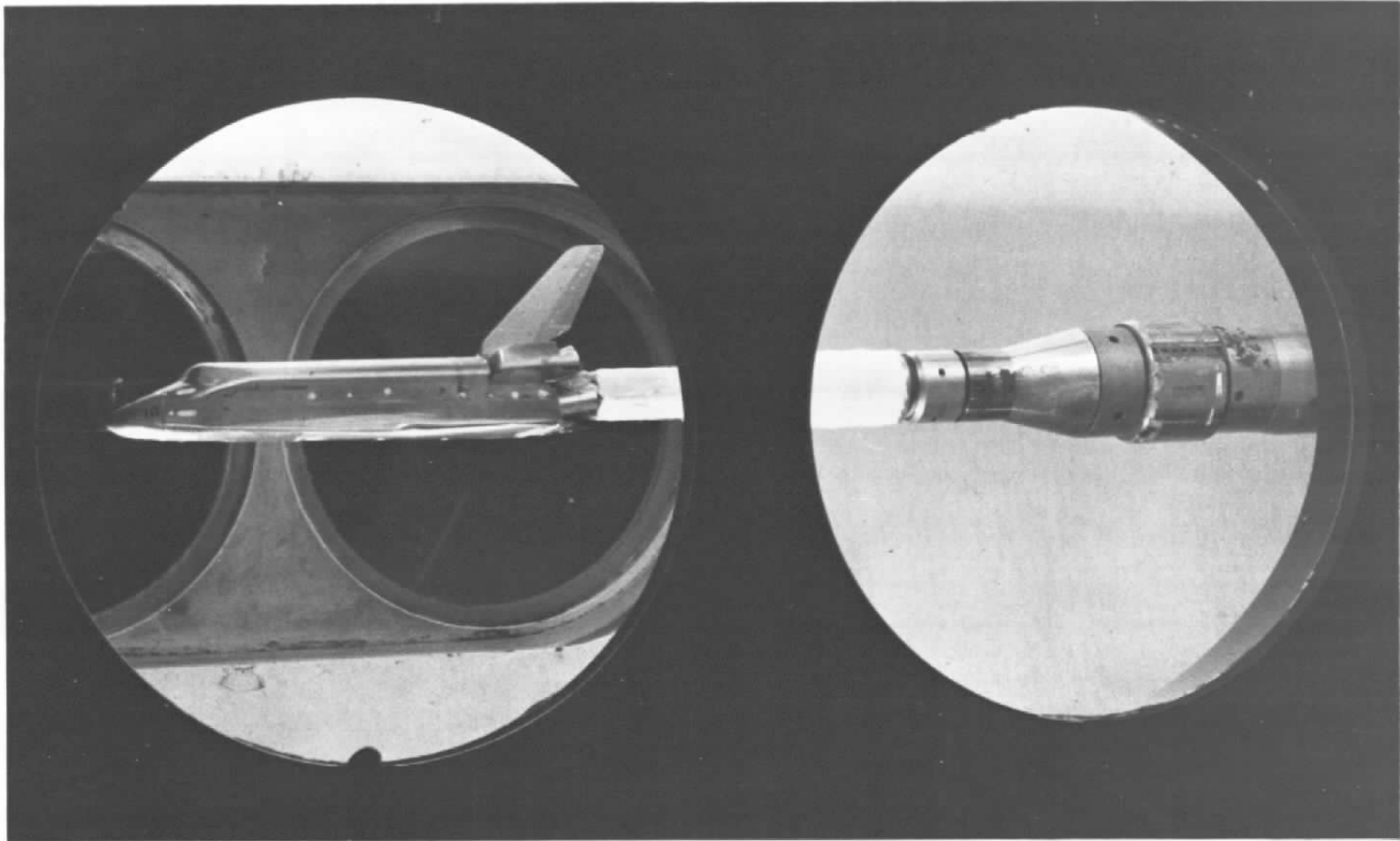
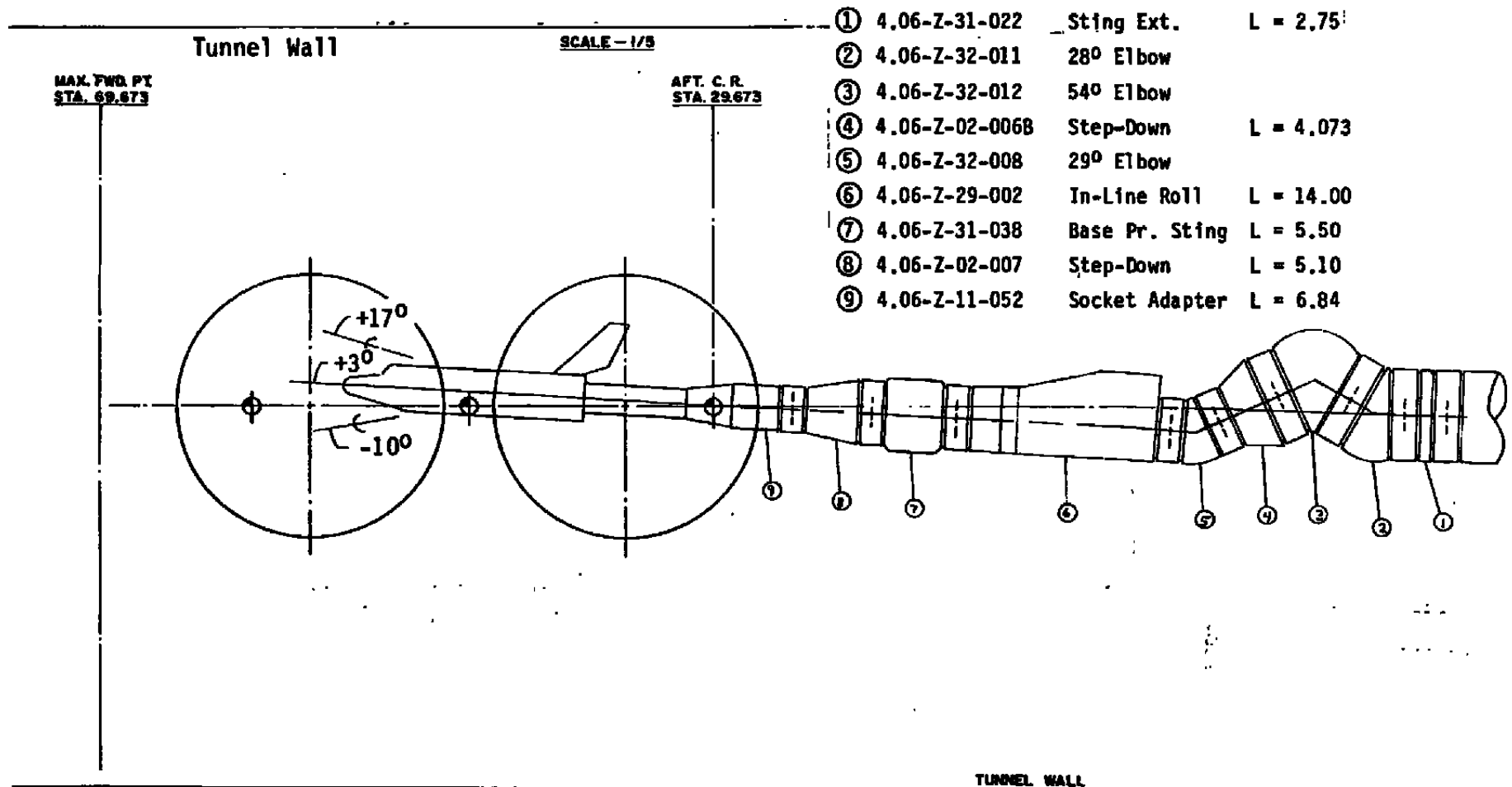

Figure 2. Shuttle Orbiter 1.25% Scale Model



a. Low-ALPHA

Figure 3. Typical Model Installation



b. Low-ALPHA  
Figure 3. Continued

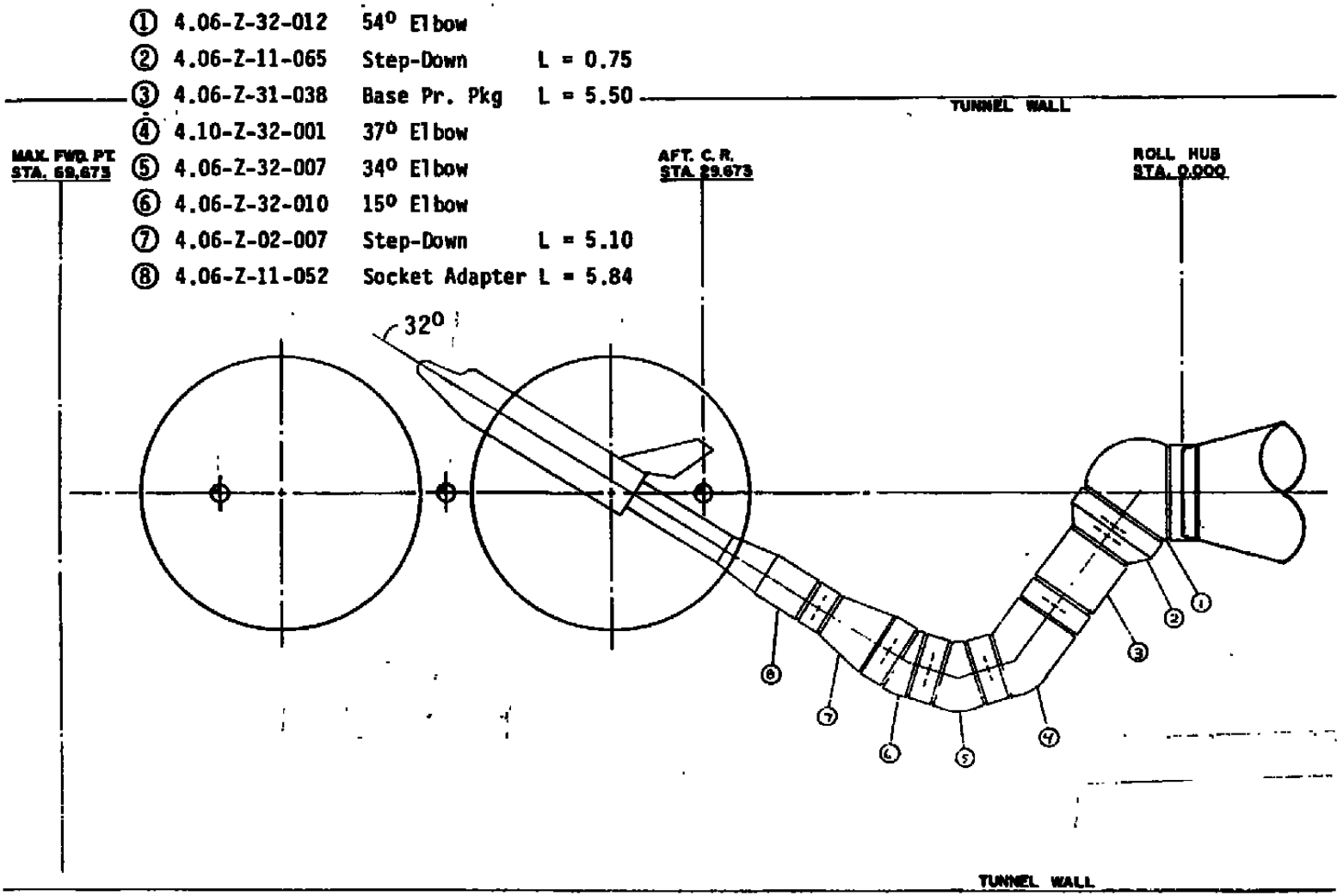

c. High ALPHA  
 Figure 3. Concluded

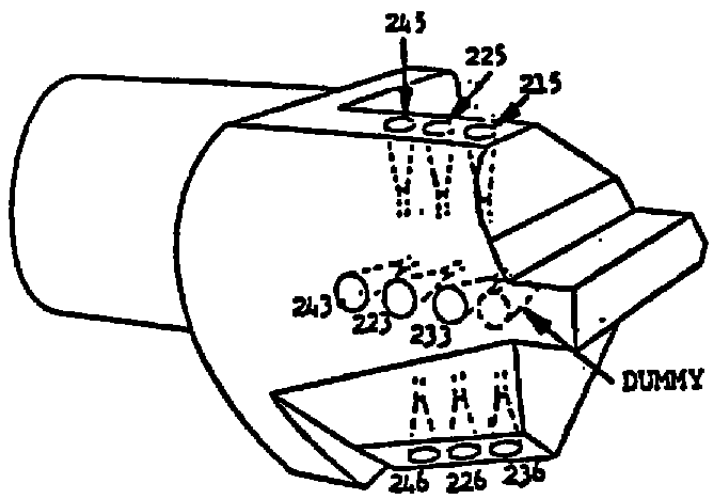

OMS POD

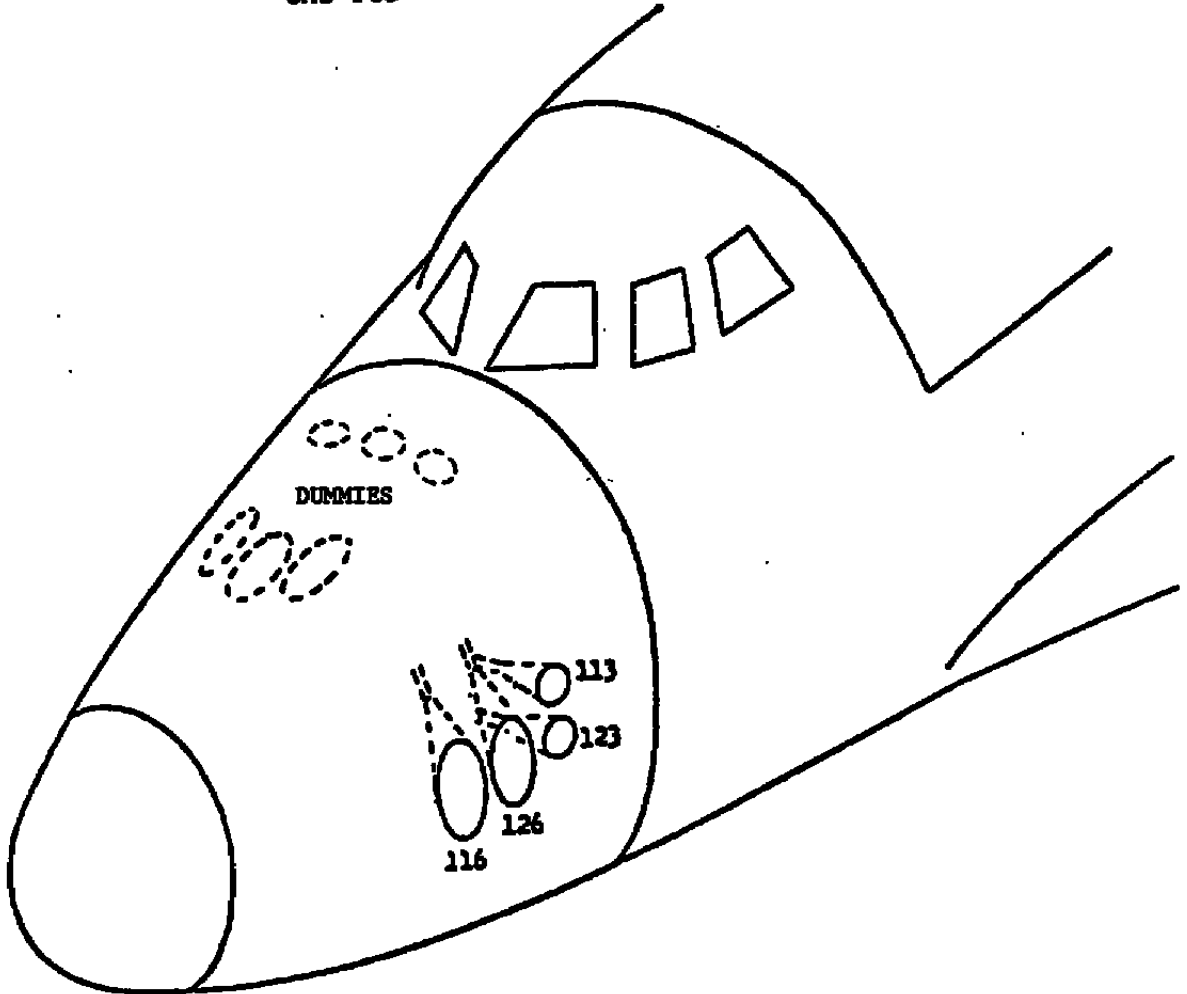

a. Left-side Jets

Figure 4. Location of RCS Jets

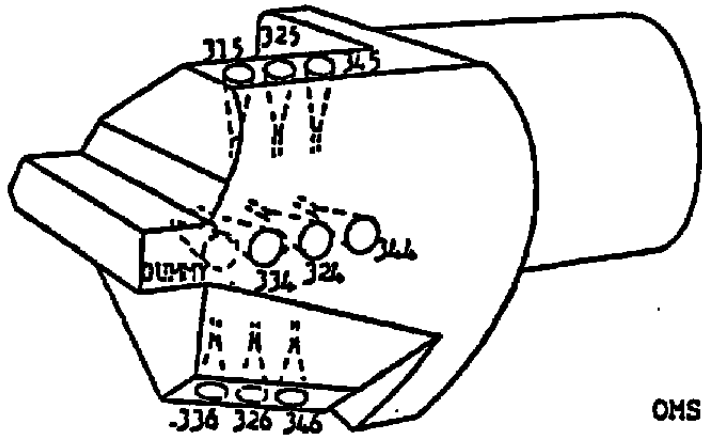

OMS POD

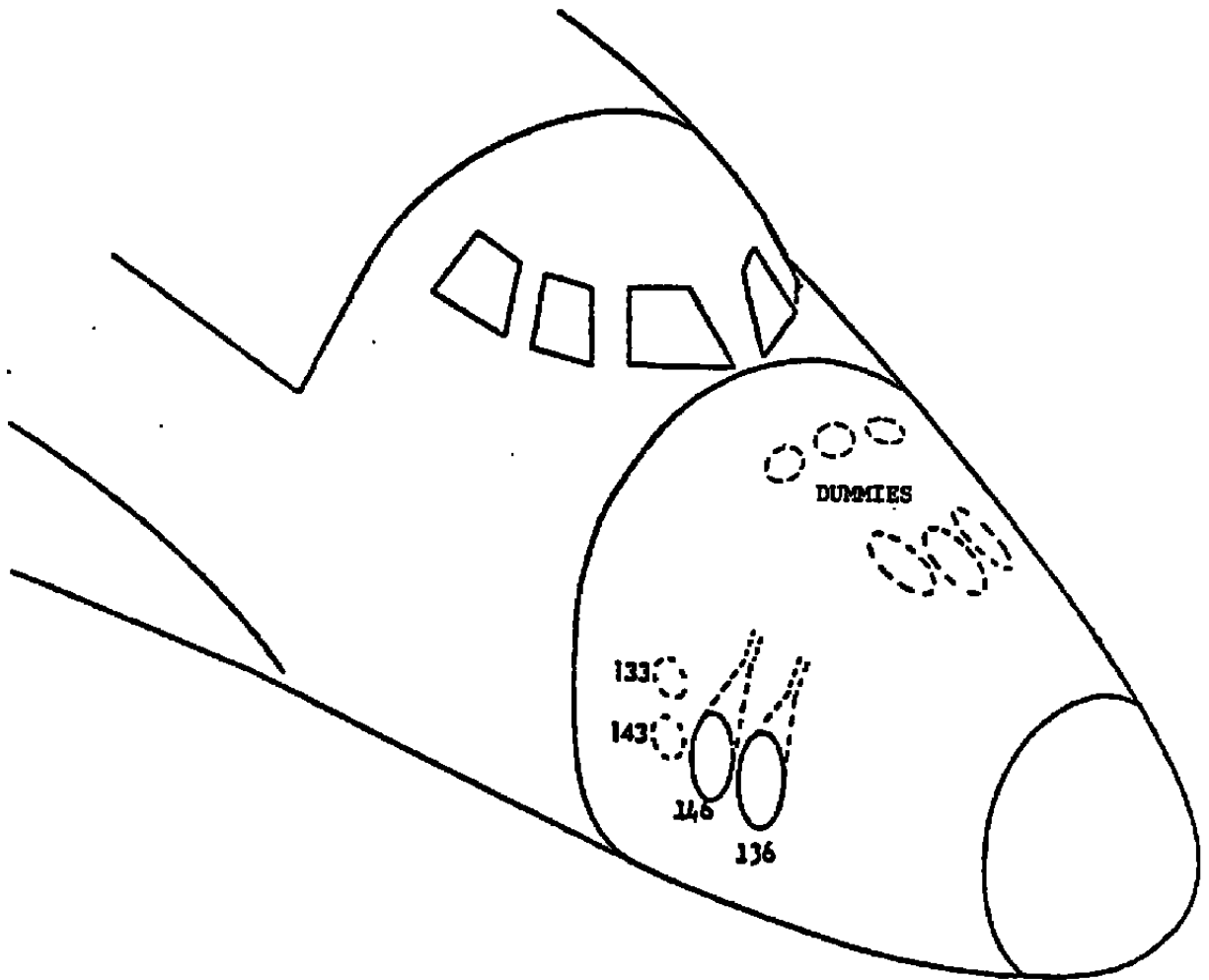

b. Right-side Jets

Figure 4. Concluded

**Table 1. RCS Configurations**

**a. Firing Jets**

CONFIG	FLS				FRS				ALS						ARS						
	S 113	D 116	S 123	D 126	S 133	D 136	S 143	D 146	S 223	U 225	D 226	S 233	D 236	S 243	U 245	D 246	U 325	D 326	D 336	U 345	D 346
1										X					X						
2															X						
3											X					X					
4																X					
5									X					X							
6									X			X		X							
7														X							
8	X		X		X		X														
9											X					X	X			X	
10		X		X		X		X			X		X			X		X	X		X
11		X		X		X		X													
12											X		X			X		X	X		X
13																					
14					X		X														
15	X		X																		

X - Jet Firing  
 S - Side Firing  
 D - Down Firing  
 U - Up Firing

**Table 1. (Continued)**

**b. RCS Parameters**

Config.	NFLS	NFRS	NALS	NARS	N
1	0	0	2	0	2
2	↓	↓	1	↓	1
3	↓	↓	2	↓	2
4	↓	↓	1	↓	1
5	↓	↓	2	↓	2
6	↓	↓	3	↓	3
7	↓	↓	1	↓	1
8	2	2	0	↓	4
9	0	0	2	2	↓
10	2	2	3	3	10
11	↓	↓	0	0	4
12	0	0	3	3	6
13	↓	↓	0	0	0
14	↓	2	↓	↓	2
15	2	0	↓	↓	↓

**Table 1. (Continued)**

**c. RCS Parameters (Continued)**

Config.	K1	K2	KM1 $\frac{10^{-3} \text{lbm/sec}}{\text{psia} \cdot R^{0.5}}$	KM2 $\frac{10^{-3} \text{lb/sec}}{\text{psia} \cdot R^{0.5}}$	KTHFLS ( $10^{-3} \text{lb/psia}$ )	KTHFRS ( $10^{-3} \text{lb/psia}$ )	KTHALS ( $10^{-3} \text{lb/psia}$ )	KTHARS ( $10^{-3} \text{lb/psia}$ )
1	0	0.9993	0	1.1732	0	0	3.4535	0
2	↓	1.0000	↓	0.5866	↓	↓	1.7298	↓
3	↓	0.9997	↓	1.1960	↓	↓	3.4957	↓
4	↓	1.0000	↓	0.5972	↓	↓	1.7418	↓
5	↓	0.9995	↓	1.1887	↓	↓	3.519	↓
6	↓	0.9977	↓	1.7861	↓	↓	5.2800	↓
7	↓	1.0000	↓	0.6052	↓	↓	1.7912	↓
8	0.9968	0	2.4645	0	3.5754	3.6932	0	↓
9	0	0.9973	0	2.3852	0	0	3.4957	3.5099
10	0.9983	↓	2.3779	3.5603	3.4994	3.5169	5.2480	5.2033
11	0.9970	0	↓	0	↓	↓	0	0
12	0	0.9991	0	3.5603	0	0	5.2480	5.2033
13	↓	0	↓	0	↓	↓	0	0
14	0.9973	↓	1.2584	↓	↓	3.6932	↓	↓
15	↓	↓	1.2061	↓	3.5754	0	↓	↓

**Table 1. (Concluded)**  
**d. RCS Parameters (Concluded)**

<b>Config.</b>	<b>KT1 (10<sup>-3</sup>lbf/psia)</b>	<b>KT2 (10<sup>-3</sup>in-lbf/psia)</b>	<b>KT3 (10<sup>-3</sup>lbf/psia)</b>	<b>KT4 (10<sup>-3</sup>in-lbf/psia)</b>	<b>KT5 (10<sup>-3</sup>in-lbf/psia)</b>
1	-2.669	18.63	0.0	0.0	-5.428
2	-1.428	9.571	↓	↓	-2.826
3	3.080	-17.28	0.8514	-4.323	5.028
4	1.400	-7.923	0.3777	-1.909	2.331
5	0.0	0.0	3.392	-19.48	3.888
6	↓	↓	5.313	-25.96	5.898
7	↓	↓	1.753	-9.724	1.959
8	0.1567	1.157	-1.310	-10.39	-0.1927
9	-0.1786	1.863	1.143	-4.317	10.83
10	14.44	-13.63	0.0	0.0	0.0
11	4.711	40.83	↓	↓	↓
12	9.907	-55.98	↓	↓	↓
13	0.0	0.0	↓	↓	↓
14*	—	—	—	—	—
15	0.6287	-1.099	3.717	25.24	-0.1699

\*Not Calibrated

TABLE 2. ESTIMATED UNCERTAINTIES

a. Measured Parameters

Parameter Designation	Steady-State Estimated Measurement*						Range	Type of Measuring Device	Type of Recording Device	Method of System Calibration	
	Precision Index (S)			Bias (B)		Uncertainty $\pm (B + 1.95S)$					
	Percent of Reading	Unit of Measurement	Degree of Freedom	Percent of Reading	Unit of Measurement	Percent of Reading					Unit of Measurement
PT, psia		0.1	>30		0.1		0.3	<900	Piezoelectric Digital Pressure Transducer	Digital data acquisition system analog-to-digital converter	In-place application of multiple pressure levels measured with a pressure measuring device calibrated in the Standards Lab
PTS, PS1, PC1A, PC2A, PFILM, PTV1, psia		0.22	>30		1.5		1.9	<2000	Servo variable capacitance pressure transducer	"	"
DPV1, psid		0.006	>30		0.20		0.22	<50	"	"	"
TT, TTV1, °R		1	>30		2		4	492 to 990	Chromel-Alumel thermocouple	Digital thermometer microprocessor	Thermocouple verification of NBS conformity/voltage substitution calibration
MDO7, lbm/sec (Hotfilm)		0.0005 lbm/sec or 2.5% of reading, which ever is less	>30		0+		0.001 lbm/sec or 5% of reading, which ever is less	0.00004 to 0.05	TSI thermal flow meter	TSI constant temperature anemometer	Factory calibration traceable to NBS
ALPI, deg		0.025	>30		0+		0.05	± 15	Potentiometer	Digital data acquisition system analog-to-digital converter	Hidenhain rotary encoder ROD700 Resolution: 0.0006 deg Overall accuracy: 0.001 deg
PHI1, deg		0.15	>30		0+		0.30	± 180	"	"	"
Normal Force, lbf		0.8			0.4		2	± 400	NASA 5505 strain gage balance	"	Hanging precision weights
Pitching Moment, in-lbf		0.7			0.6		2	± 400	"	"	"
Side Force, lbf		0.1			0.1		0.3	± 60	"	"	"
Yawing Moment, in-lbf		0.1			0.1		0.3	± 40	"	"	"
Rolling Moment, in-lbf		0.15			0.1		0.4	± 40	"	"	"

\*Reference: Abernethy, R. B. et al and Thompson, J. W. "Handbook Uncertainty in Gas Turbine Measurements" AEDC-TR-73-5, February 1973.

TABLE 2. CONCLUDED

b. Calculated Parameters

Parameter Designation	Steady-State Estimated Measurement*						Nominal Value
	Precision Index (S)		Bias (B)		Uncertainty $\pm (B + t_{95}S)$		
	Percent of Reading	Unit of Measurement	Percent of Reading	Unit of Measurement	Percent of Reading	Unit of Measurement	
CN		0.021		0.011		0.053	1.8
CLM		0.0032		0.0026		0.0090	-0.23
CY		0.0025		0.0025		0.0075	0.19
CLN		0.00031		0.00025		0.00087	-0.05
CLL		0.00046		0.00022		0.00114	0.02
ALPHA, deg		0.025		0.05		0.1	46
BETA, deg		0.03		0.06		0.12	6
MDOT, lbm/sec (venturi)	0.2		1.2		1.6		0.2
M	0.08		0+		0.16		5.96
RE, ft-1	0.37		0.43		1.2		0.766 x 10 <sup>6</sup>
Q, psia	0.42		0.24		1.1		0.661
P, psia	0.56		0.26		1.4		0.0266
T, °R	0.19		0.24		0.62		103.8
V, ft/sec	0.06		0.12		0.24		2976

\*Reference: Abernethy, R.B. et al and Thompson, J. W. "Handbook Uncertainty in Gas Turbine Measurements."

AEDC-TR-73-5, February 1973.

**Table 3. Test Run Summary**

**a. Calibration Runs**

<b>CONFIGURATION</b>	<b>CHAMBER PRESSURE CALIBRATIONS</b>	<b>THRUST CALIBRATIONS</b>
1	8006, 8007	8043, 8044
2	8008, 8009	8045, 8046
3	8010, 8011	8047, 8048
4	-	8049, 8050
5	-	8051, 8052
6	8012	8053
7	-	8054
8	8013	8055
9	8014	8056
10	8015, 8016	8057, 8058
11	-	8065, 8066
12	8018, 8019	8132, 8133
13	-	-
14	8017	-
15	-	8071

Table 3. (Continued)

b. ALPHA = -11 to 17 deg, BETA = 0 deg

CONFIG	NOMINAL MR											
	0	0.001	0.002	0.003	0.004	0.01	0.015	0.02	0.03	0.04	0.05	0.06
1	1,2					3		4	5	6		
2	8							9				
3	10, 116*, 118+					11		12, 117*, 119+	13	14		
4								15				
5	16,34,81, 114*,120+	19,84	22,87	90	25,93, 115*,121*	28,96	99	31,102	105	37,108	111	
6	40				41	42		43		44		
7	45				46	47		48				
8	51				52	57		58		60		
9	49							50				
10	68							69		70	71	
11	72							73	74,75	76		
12	77								78		79	80
13	7											
14												
15	61				62	65		66		67		

29

\* ELEVON = -20 deg  
 + ELEVON = +20 deg

Table 3. (Continued)

c. ALPHA = -11 to 17 deg, BETA = ±6 deg

CONFIG	BETA = -6 DEG NOMINAL MR											
	0	0.001	0.002	0.003	0.004	0.01	0.015	0.02	0.03	0.04	0.05	0.06
5	17, 35, 82	20, 85	23, 88	91	26, 94	29, 97	100	32, 103	106	38, 109	112	
8	59,**				53, 55							
15					63							

36

CONFIG	BETA = +6 DEG NOMINAL MR											
	0	0.001	0.002	0.003	0.004	0.01	0.015	0.02	0.03	0.04	0.05	0.06
5	18, 36, 83	21, 86	24, 89	92	27, 95	30, 98	101	33, 104	107	39, 110	113	
8					54, 56							
15					64							

\*\*BETA Sweep, +6 to -6 deg

Table 3. (Continued)

d. ALPHA = 18 to 46 deg. BETA = 0 deg

CONFIG	NOMINAL MR											
	0	0.001	0.002	0.003	0.004	0.01	0.015	0.02	0.03	0.04	0.05	0.06
1	142					143		144	145	146, 147		
2								164				
3	205, 210*, 216+					206		207, 211*, 217+	208	209		
4								165				
5	172, 212*, 214+	175	178	181	184, 213*, 215+	187	190	193	196	199	202	
6	123, 148				124, 149	125, 150		126, 151		127, 152		
7	166				167	168		169				
8												
9	170							171				
15	153, 154				155	158, 159		160, 161		162, 163		

\* ELEVON = -20 deg

+ ELEVON = +20 deg

**Table 3. (Concluded)**

**e. ALPHA = 18 to 46 deg. BETA = ±6 deg**

CONFIG	BETA = -6 deg NOMINAL MR											
	0	0.001	0.002	0.003	0.004	0.01	0.015	0.02	0.03	0.04	0.05	0.06
5	173	176	179	182	185	188	191	194	197	200	203	
8												
15					156							

32

CONFIG	BETA = +6 deg NOMINAL MR											
	0	0.001	0.002	0.003	0.004	0.01	0.015	0.02	0.03	0.04	0.05	0.06
5	174	177	180	183	186	189	192	195	198	201	204	
8												
15					157							

CALSPAN CORPORATION  
 AFDC DIVISION  
 VON KARMAN GAS DYNAMICS FACILITY  
 ARNOLD AIR FORCE STATION, TENNESSEE  
 NASA 04352  
 PAGE 7

DATE COMPUTED 6-FEB-87  
 TIME COMPUTED 051433Z  
 DATE RECORDED 6-FEB-87  
 TIME RECORDED 514216  
 PROJECT NUMBER Y 9-27

RUN M PT TT Q P T RC A REF LENGTHS(CLN,CLN,CLL)  
 199 5.96 40.33 349.7 0.662 0.027 104.9 0.755E+06 60.525 5.935 11.709 11.709  
 ELEVON 0 CONFIG 5

---BGDV AXIS COEFFICIENTS---

---THRUST INCLUDED---

---THRUST REMOVED---

PN	ALPHA	BETA	CM	CLM	CV	CLM	CLL	CMR	CLNR	CVR	CLNR	CLLR
1	18.02	0.01	0.3809	-0.0122	0.0931	-0.0410	0.0046	0.3809	-0.0122	0.0089	0.0003	-0.0036
2	20.00	0.01	0.4583	-0.0128	0.0935	-0.0410	0.0043	0.4583	-0.0128	0.0093	0.0003	-0.0039
3	22.00	0.01	0.5297	-0.0127	0.0941	-0.0414	0.0045	0.5297	-0.0127	0.0099	-0.0001	-0.0037
4	24.00	0.02	0.6075	-0.0142	0.0948	-0.0419	0.0047	0.6075	-0.0142	0.0104	-0.0005	-0.0036
5	26.00	0.02	0.6981	-0.0166	0.0951	-0.0421	0.0045	0.6681	-0.0166	0.0107	-0.0007	-0.0037
6	28.00	0.02	0.7715	-0.0192	0.0948	-0.0419	0.0044	0.7715	-0.0192	0.0104	-0.0005	-0.0038
7	30.03	0.03	0.8578	-0.0231	0.0936	-0.0416	0.0042	0.8578	-0.0231	0.0092	-0.0002	-0.0041
8	32.00	0.03	0.9455	-0.0273	0.0933	-0.0415	0.0041	0.9455	-0.0273	0.0089	-0.0001	-0.0042
9	34.00	0.03	1.0340	-0.0320	0.0929	-0.0415	0.0039	1.0340	-0.0320	0.0087	-0.0002	-0.0044
10	36.00	0.03	1.1239	-0.0381	0.0918	-0.0412	0.0036	1.1239	-0.0381	0.0082	-0.0002	-0.0046
11	38.00	0.04	1.2166	-0.0444	0.0924	-0.0414	0.0038	1.2166	-0.0444	0.0088	-0.0004	-0.0044
12	40.00	0.04	1.3076	-0.0517	0.0926	-0.0416	0.0041	1.3076	-0.0517	0.0090	-0.0006	-0.0041
13	42.00	0.04	1.4048	-0.0593	0.0934	-0.0420	0.0043	1.4048	-0.0593	0.0096	-0.0009	-0.0039
14	44.00	0.04	1.4999	-0.0671	0.0933	-0.0420	0.0043	1.4999	-0.0671	0.0098	-0.0009	-0.0038
15	46.00	0.05	1.5906	-0.0759	0.0939	-0.0421	0.0046	1.5904	-0.0759	0.0101	-0.0010	-0.0036
16	46.08	0.05	1.5874	-0.0753	0.0933	-0.0421	0.0046	1.5874	-0.0753	0.0096	-0.0010	-0.0036

Sample 1. Tabulated Force and Moment Data

CALSPAN CORPORATION  
 AEGE DIVISION  
 VON KARMAN GAS DYNAMICS FACILITY  
 ARNOLD AIR FORCE STATION, TENNESSEE  
 NASA DASS?  
 PAGE 5

DATE COMPUTED 6-FEB-67  
 TIME COMPUTED 0543:36  
 DATE RECORDED 6-FEB-67  
 TIME RECORDED 542:16  
 PROJECT NUMBER V 8-27

RUN 199 M 5.96 PT 40.33 TT 849.7 Q 0.662 P 0.027 T 104.9 RE 0.755E+06 A 60.525 REF LENGTHS(CLM,CLN,CLL) 5.935 11.709 11.709  
 ELEVON 0 CONFIG 5

---MOMENTUM RATIOS---

PN	ALPI	PHII	MRFLST	MRFRST	MRALST	MRARST	MRFLSA	MRFRSA	MRALSA	MRARSA	MR	PCI	PC2
1	-13.95	0.00	0.0000	0.0000	0.0466	0.0000	0.0000	0.0000	0.0419	0.0000	0.0419	0.0000	994.5851
2	-11.98	0.00	0.0000	0.0000	0.0466	0.0000	0.0000	0.0000	0.0419	0.0000	0.0419	0.0000	994.5060
3	-9.98	0.00	0.0000	0.0000	0.0466	0.0000	0.0000	0.0000	0.0419	0.0000	0.0419	0.0000	994.4968
4	-7.98	0.00	0.0000	0.0000	0.0467	0.0000	0.0000	0.0000	0.0420	0.0000	0.0420	0.0000	994.4420
5	-5.99	0.00	0.0000	0.0000	0.0467	0.0000	0.0000	0.0000	0.0420	0.0000	0.0420	0.0000	994.4632
6	-3.99	0.00	0.0000	0.0000	0.0467	0.0000	0.0000	0.0000	0.0420	0.0000	0.0420	0.0000	994.4161
7	-1.99	0.00	0.0000	0.0000	0.0467	0.0000	0.0000	0.0000	0.0420	0.0000	0.0420	0.0000	994.4065
8	0.00	0.00	0.0000	0.0000	0.0467	0.0000	0.0000	0.0000	0.0420	0.0000	0.0420	0.0000	994.3801
9	2.00	0.00	0.0000	0.0000	0.0466	0.0000	0.0000	0.0000	0.0419	0.0000	0.0419	0.0000	994.3106
10	3.99	0.00	0.0000	0.0000	0.0463	0.0000	0.0000	0.0000	0.0416	0.0000	0.0416	0.0000	994.3037
11	5.99	0.00	0.0000	0.0000	0.0462	0.0000	0.0000	0.0000	0.0416	0.0000	0.0416	0.0000	994.2072
12	7.99	0.00	0.0000	0.0000	0.0462	0.0000	0.0000	0.0000	0.0416	0.0000	0.0416	0.0000	994.2793
13	9.99	0.00	0.0000	0.0000	0.0464	0.0000	0.0000	0.0000	0.0417	0.0000	0.0417	0.0000	994.1793
14	11.98	0.00	0.0000	0.0000	0.0463	0.0000	0.0000	0.0000	0.0417	0.0000	0.0417	0.0000	994.2358
15	13.98	0.00	0.0000	0.0000	0.0464	0.0000	0.0000	0.0000	0.0417	0.0000	0.0417	0.0000	994.2517
16	14.05	-0.01	0.0000	0.0000	0.0464	0.0000	0.0000	0.0000	0.0417	0.0000	0.0417	0.0000	994.1792

Sample 1. Continued

CALSPAN CORPORATION  
 AECC DIVISION  
 VON KARMAN GAS DYNAMICS FACILITY  
 ARNOLD AIR FORCE STATION, TENNESSEE  
 NASA O4352  
 PAGE 3

DATE COMPUTED 6-FEB-67  
 TIME COMPUTED 05:43:35  
 DATE RECORDED 6-FEB-67  
 TIME RECORDED 5:42:16  
 PROJECT NUMBER V B-27

RUN M PT TT Q P T RE A REF LENGTHS(CLM,CLN,CLL)  
 139 5.94 40.33 849.7 0.662 0.027 104.9 0.755E+06 60.525 5.935 11.709 11.709

ELEVON CONFIG  
 0 5

---CONDITIONS---

---MASS FLOW---

PN	ALPI	PHI	PT	TT	Q	P	MDOT	WC	TC
1	-13.95	0.00	40.33	849.7	0.662	0.027	0.053	0.052	521.626
2	-11.98	0.00	40.33	849.7	0.662	0.027	0.052	0.052	521.625
3	-9.99	0.00	40.33	849.7	0.662	0.027	0.052	0.052	521.628
4	-7.98	0.00	40.23	849.7	0.661	0.027	0.052	0.052	521.625
5	-5.99	0.00	40.23	849.7	0.661	0.027	0.052	0.052	521.627
6	-3.99	0.00	40.23	849.7	0.661	0.027	0.051	0.052	521.641
7	-1.99	0.00	40.23	849.7	0.661	0.027	0.051	0.052	522.031
8	0.00	0.00	40.24	849.7	0.661	0.027	0.051	0.052	522.631
9	2.00	0.00	40.33	849.7	0.662	0.027	0.052	0.052	522.631
10	3.99	0.00	40.64	849.7	0.667	0.027	0.051	0.052	522.630
11	5.99	0.00	40.64	849.7	0.667	0.027	0.051	0.052	522.629
12	7.99	0.00	40.64	849.7	0.667	0.027	0.051	0.052	522.633
13	9.99	0.00	40.54	849.7	0.666	0.027	0.052	0.052	522.630
14	11.98	0.00	40.55	849.7	0.666	0.027	0.051	0.052	522.633
15	13.98	0.00	40.54	849.7	0.666	0.027	0.051	0.052	522.630
16	14.05	-0.01	40.54	849.7	0.666	0.027	0.052	0.052	523.634

MODEL FLOWFIELD PHOTOGRAPHS TAKEN AT ALPHA = 10.02, 22.01, 26.07, 29.94, 34.14, 38.18, 42.25, 46.11.

Sample 1. Continued

CALSPAN CORPORATION  
 AEDC DIVISION  
 VOY KIRKIN GAS DYNAMICS FACILITY  
 ARNOLD AIR FORCE STATION, TENNESSEE  
 NASA D4352  
 PAGE 4

DATE COMPUTED 6-FEB-87  
 TIME COMPUTED 05:43:36  
 DATE RECORDED 6-FEB-87  
 TIME RECORDED 5:42:16  
 PROJECT NUMBER V 8-27

RUN M FT TT Q P T RE A REF LENGTHS(CLM,CLM,CLL)  
 199 5.96 40.33 849.7 0.662 0.027 104.9 0.755E+06 60.525 5.935 11.709 11.709

ELEVON CONFIG  
 0 5

---THEORETICAL THRUST---

---ACTUAL THRUST---

---STING---

PN	ALPI	PHII	TPLST	TFRST	TALST	TARST	TFLSA	TFRSA	TALSA	TARSA	PTS	PSI
1	-13.95	0.00	0.0000	0.0000	3.8222	0.0000	0.0000	0.0000	3.4992	0.0000	995.0827	996.1296
2	-11.98	0.00	0.0000	0.0000	3.8235	0.0000	0.0000	0.0000	3.4983	0.0000	995.0835	996.0239
3	-9.98	0.00	0.0000	0.0000	3.8235	0.0000	0.0000	0.0000	3.4989	0.0000	994.9943	995.9781
4	-7.98	0.00	0.0000	0.0000	3.8223	0.0000	0.0000	0.0000	3.4987	0.0000	994.9394	995.7964
5	-5.99	0.00	0.0000	0.0000	3.8234	0.0000	0.0000	0.0000	3.4987	0.0000	994.9607	995.7992
5	-3.95	0.00	0.0000	0.0000	3.8222	0.0000	0.0000	0.0000	3.4984	0.0000	994.9136	995.7864
7	-1.93	0.00	0.0000	0.0000	3.8221	0.0000	0.0000	0.0000	3.4985	0.0000	994.9039	995.7096
8	0.00	0.00	0.0000	0.0000	3.8222	0.0000	0.0000	0.0000	3.4984	0.0000	994.8775	995.7259
9	2.00	0.00	0.0000	0.0000	3.8272	0.0000	0.0000	0.0000	3.4982	0.0000	994.8080	995.6364
10	3.99	0.00	0.0000	0.0000	3.8277	0.0000	0.0000	0.0000	3.4982	0.0000	994.8011	995.6215
11	5.99	0.00	0.0000	0.0000	3.8274	0.0000	0.0000	0.0000	3.4978	0.0000	994.7044	995.5511
12	7.99	0.00	0.0000	0.0000	3.8276	0.0000	0.0000	0.0000	3.4981	0.0000	994.7767	995.6651
13	9.98	0.00	0.0000	0.0000	3.8272	0.0000	0.0000	0.0000	3.4977	0.0000	994.6766	995.6684
14	11.98	0.00	0.0000	0.0000	3.8275	0.0000	0.0000	0.0000	3.4979	0.0000	994.7332	995.5097
15	13.98	0.00	0.0000	0.0000	3.8275	0.0000	0.0000	0.0000	3.4980	0.0000	994.7491	995.5929
16	14.05	-0.01	0.0000	0.0000	3.8272	0.0000	0.0000	0.0000	3.4977	0.0000	994.6765	995.4818

Sample 1. Concluded

NASA 0232  
 INCREMENTAL DIFFERENCES BETWEEN RUN NUMBER 3 AND BASE RUN NUMBER 1

ALPHA	DCNR	DCLMR	DCYK	DCLNR	DCLLR
-10.9083	-0.0028	0.0007	0.0021	-0.0008	0.0001
-10.0000	-0.0035	0.0011	0.0016	-0.0007	0.0000
-8.0000	-0.0047	0.0011	0.0015	-0.0006	0.0000
-6.0000	-0.0042	0.0007	0.0014	-0.0006	0.0000
-4.0000	-0.0042	-0.0004	0.0012	-0.0006	0.0000
-2.0000	-0.0021	-0.0001	0.0016	-0.0007	0.0000
0.0000	-0.0029	-0.0003	0.0014	-0.0004	-0.0000
2.0000	-0.0045	-0.0011	0.0011	-0.0004	0.0001
4.0000	-0.0045	-0.0012	0.0035	-0.0016	0.0006
6.0000	-0.0034	-0.0000	0.0040	-0.0019	0.0007
8.0000	-0.0048	-0.0010	0.0063	-0.0035	0.0018
10.0000	-0.0054	-0.0017	0.0103	-0.0054	0.0033
12.0000	-0.0065	-0.0015	0.0120	-0.0062	0.0041
14.0000	-0.0066	-0.0022	0.0106	-0.0056	0.0035
16.0000	-0.0066	-0.0028	0.0098	-0.0051	0.0032
17.1205	-0.0037	-0.0029	0.0035	-0.0045	0.0028

37

Sample 2. Tabulated Interference Data

SHUTTLE OR352

HEADING  
FIL RUN  
A 142

RUN  
142.0

M  
5.959

CONFIG  
1

MR  
0.8841E-04

SYMB FIL RUN  
A 142  
B 1

MR  
(X10<sup>-5</sup>)  
0.841  
-2.826

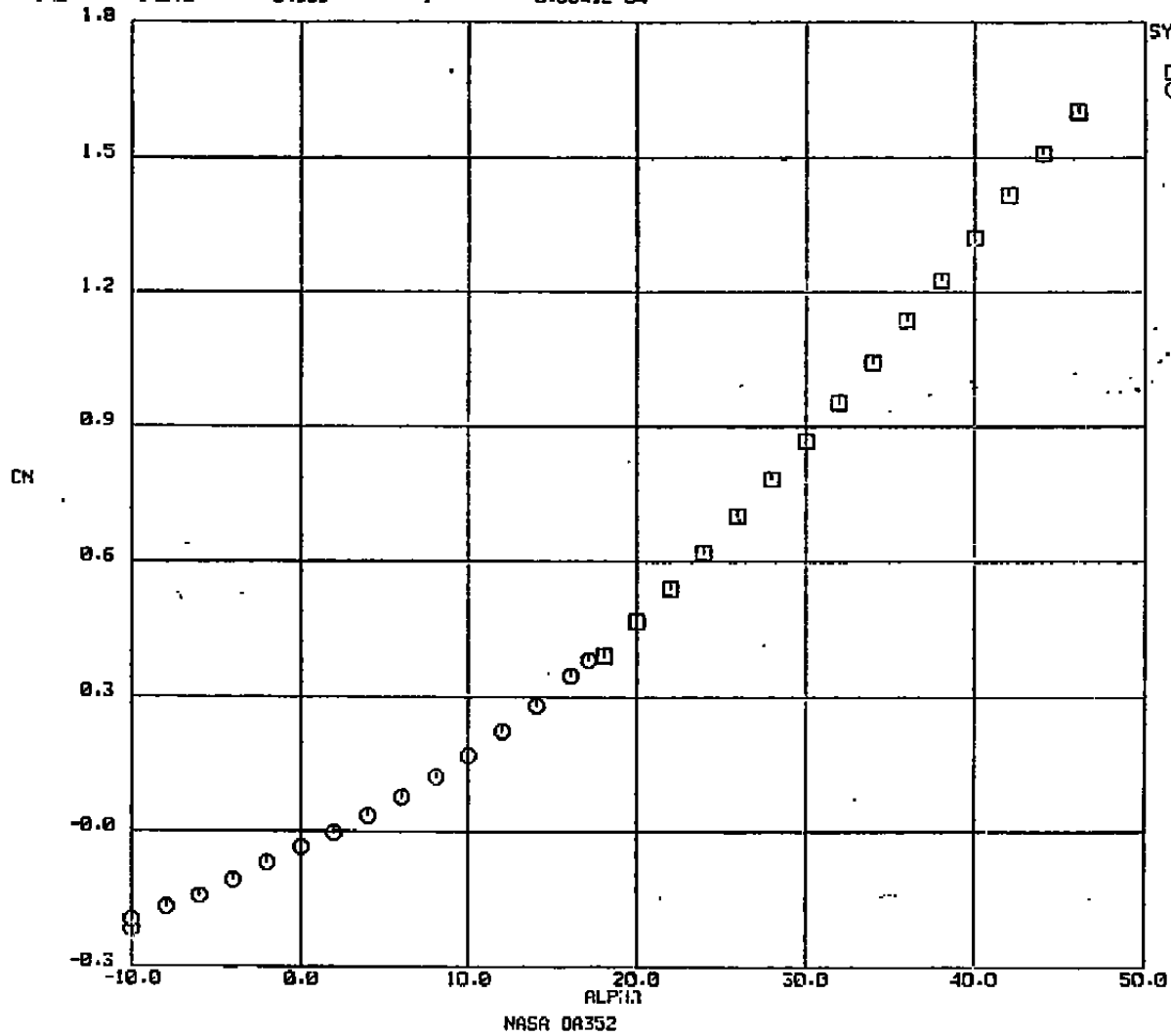

Sample 3. Plotted Force and Moment Data

SHUTTLE DA352

HEADING  
FIL RUN  
A 142

RUN  
142.0

M  
5.959

CONFIG  
1

MR  
0.8841E-04

SYMB FIL RUN  
A 142  
B 1

MR  
(X10<sup>-5</sup>)  
8.841  
-2.626

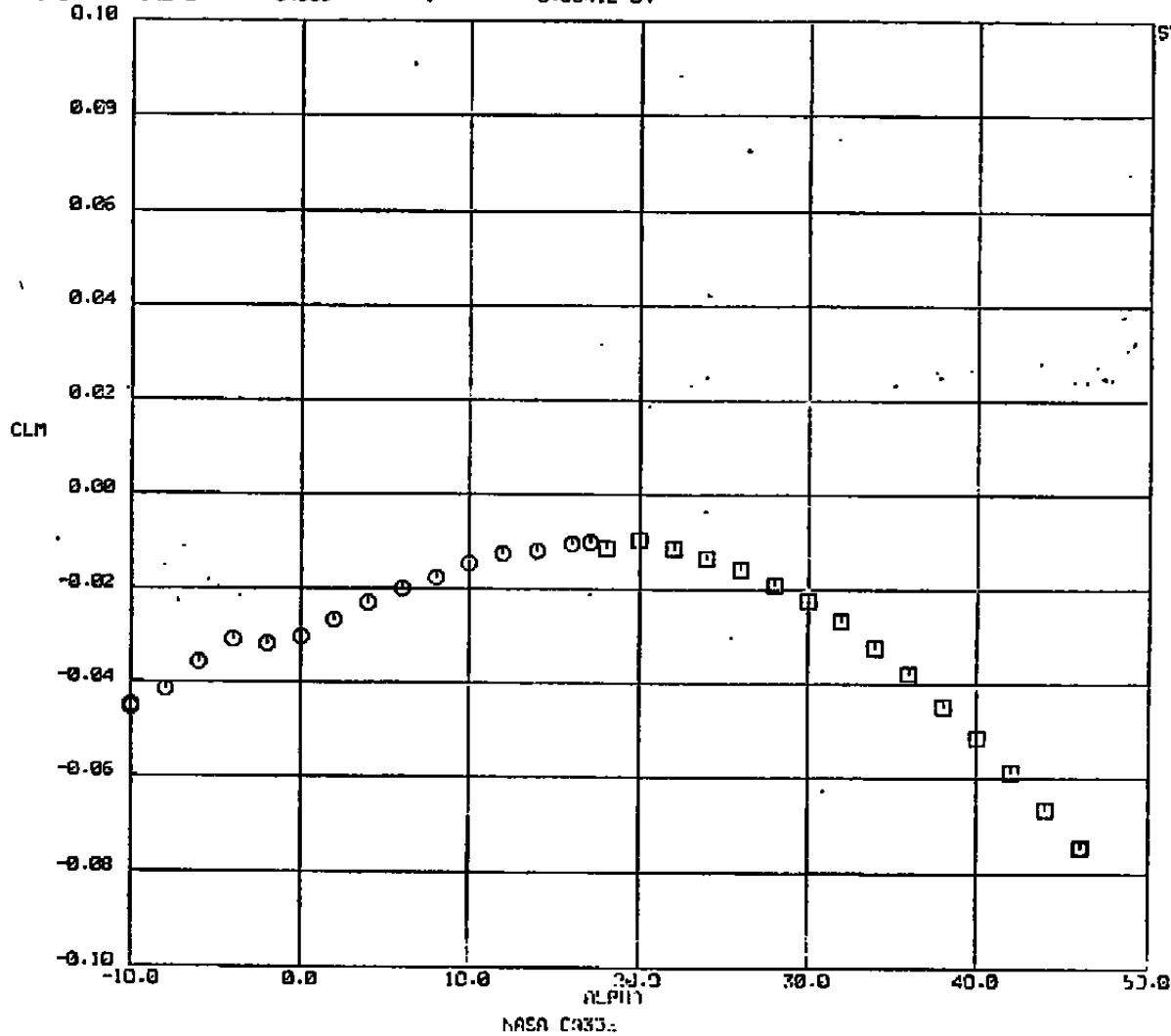

FIL RAM FILE  
A FORCE.TRA  
B FORCE1.TRA  
C TORY.TRA  
PAGE 7  
02:21  
05-FEB-07  
0:1SHUTL2.617

39

Sample 3. Continued

SHUTTLE OR352

HEADING  
FIL RUN  
n 142

RUN  
142.0

M  
5.959

CONFIG  
1

MR  
0.8841E-04

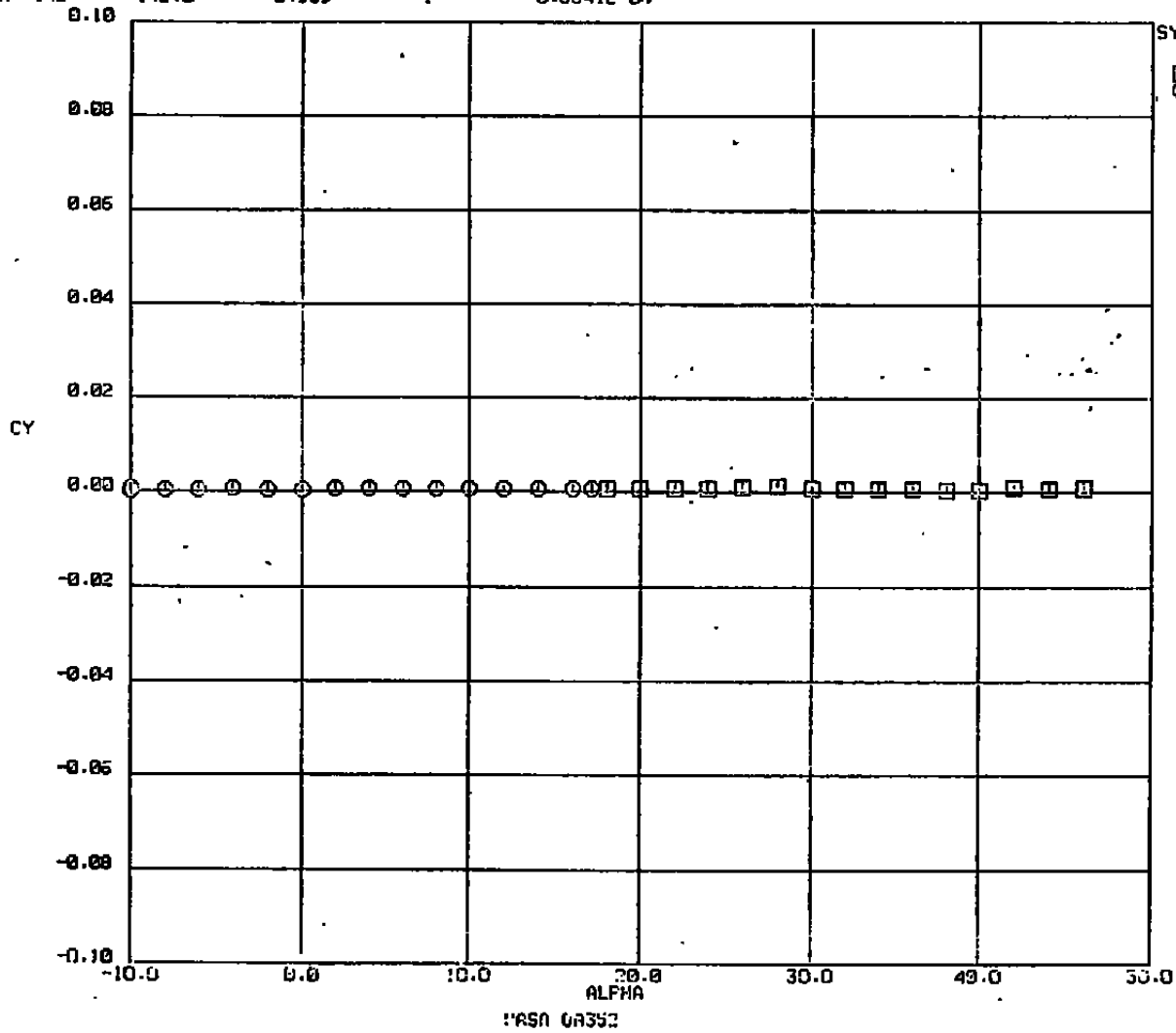

40

FIL RAM FILE  
A FORCE.TRA  
B FORCE1.TRA  
C H:DRY.TRA  
PAGE 0  
02:21  
05-FEB-87  
011SHUTL2.617

Sample 3. Continued

SHUTTLE 0A352

FEADING  
FIL RUN  
N 142

RUN  
142.0

M  
5.959

CONFIG  
1

MR  
0.8941E-04

SYMB FIL RUN  
A 142  
B 1

MR  
(X10<sup>-5</sup>)  
8.841  
-2.026

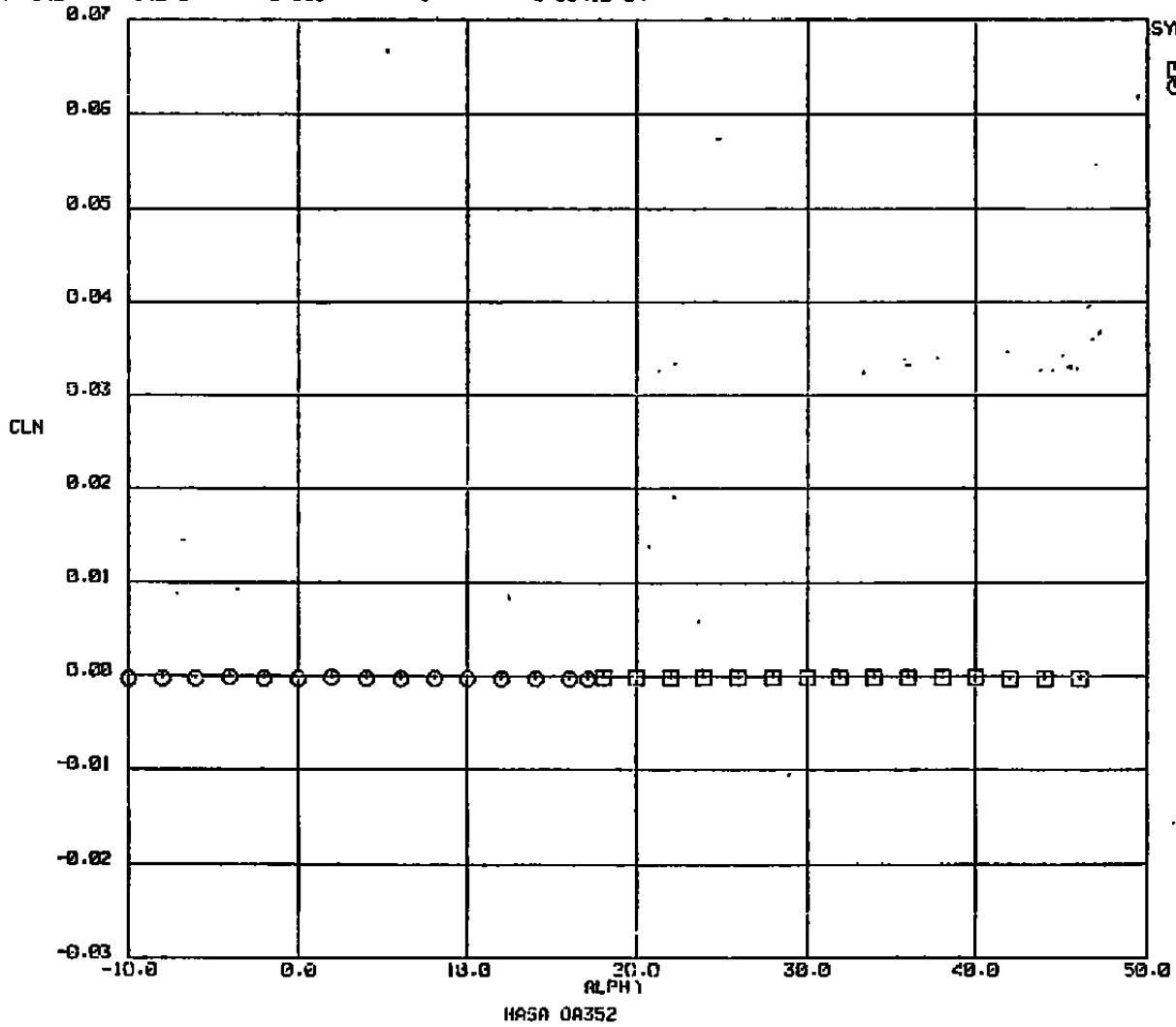

FIL RAM FILE  
A FORCE.TRA  
B FORCE1.TRA  
C THEORY.TRA  
PAGE 10  
02:21  
05-FEB-87  
011SHUTL2-617

SHUTTLE CA352

HEADING  
FIL RUN  
A 142

RUII  
142.0

M  
5.959

CONFIG  
1

MR  
0.8841E-04

SYMB FIL RUN  
C B 142  
B 1

MR  
1.10E-5  
3.341  
-2.026

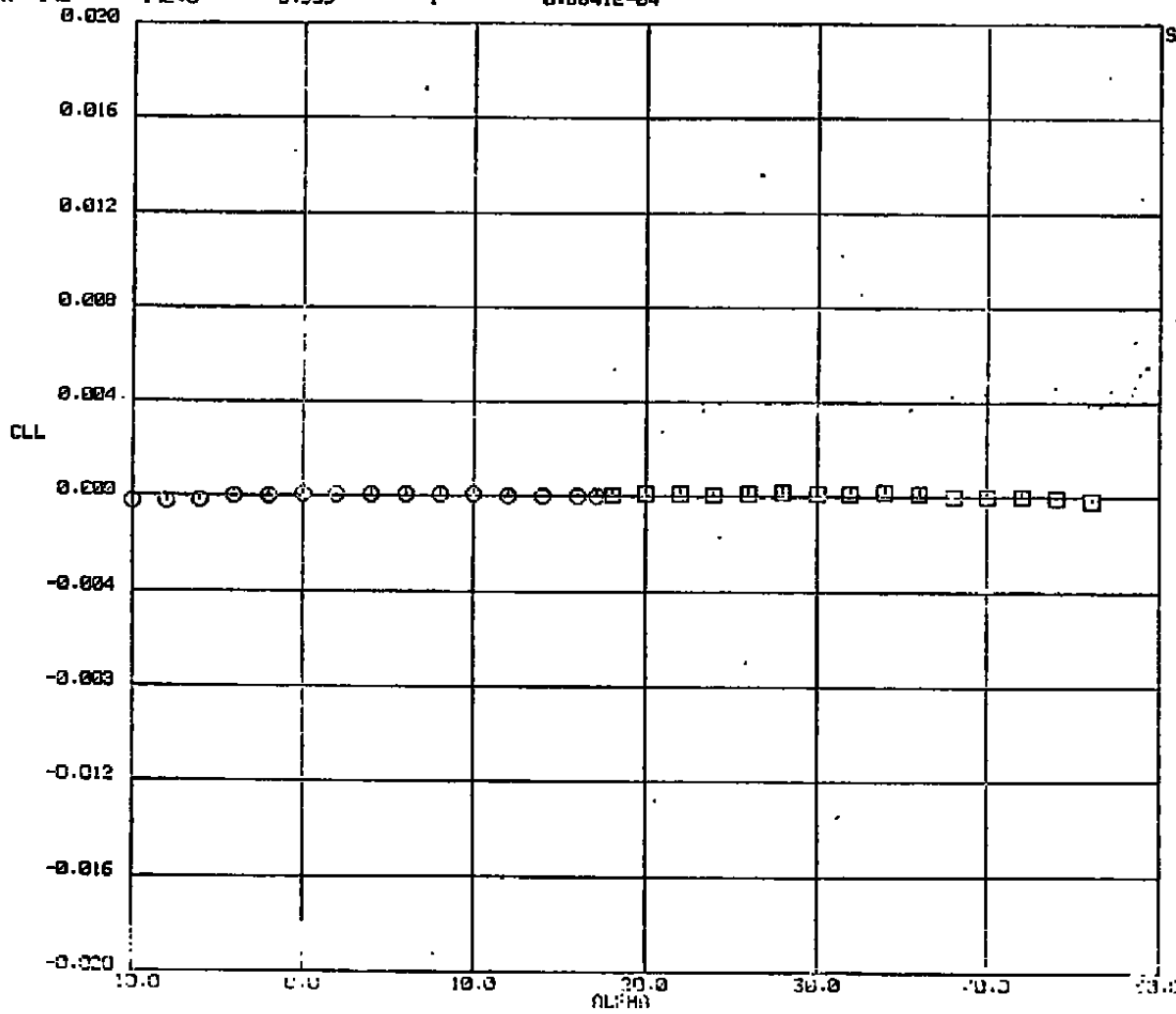

42

FIL  
A  
B  
C  
RAM FILE  
FORCE-TRA  
FORCE-TRA  
FORCE-TRA  
PAGE 0  
02:21  
PALLER-AT

Sample 3. Concluded

SHUTTLE OA352

HEADING  
FIL RUN  
A 171

RUN  
171.0

M  
0.0220

CONFIG  
P 9

MR  
0.2060E-01

SYMB FIL RUN

□ A 171  
○ A 50

MR  
(X10<sup>-2</sup>)  
2.060  
2.108

DCNR

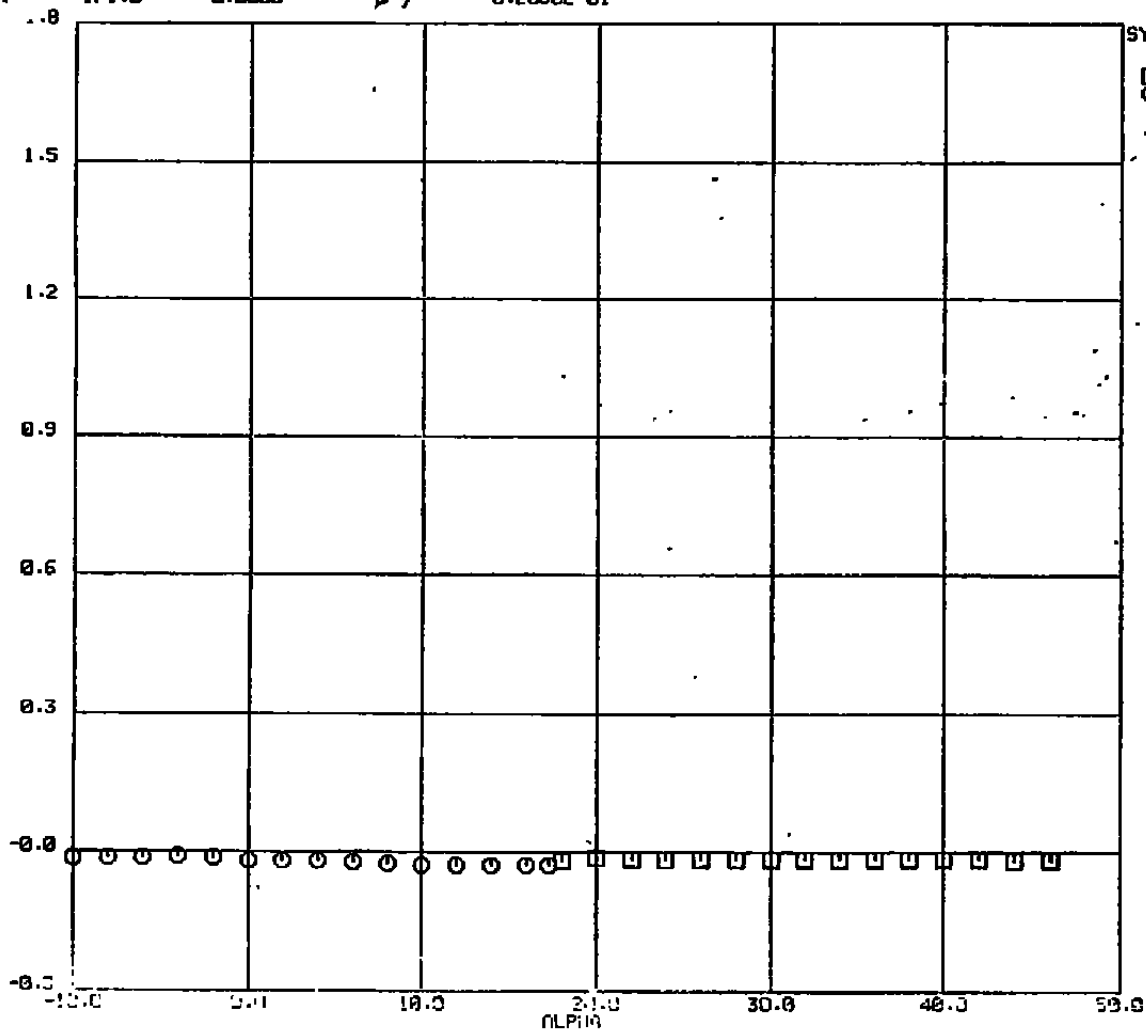

FIL RAM FILE  
A HMRAT-TRA

PAGE 1  
03:58  
04/29/87

Sample 4. Plotted Interference Data

43

SHUTTLE OR352

HEADING  
FIL RUN  
A 171

RUN  
171.0

M  
0.0000

CONFIG  
9

MR  
0.2060E-01

SYMB FIL RUN  
C A 171  
A 50

MR  
(X10<sup>-2</sup>)  
2.060  
2.100

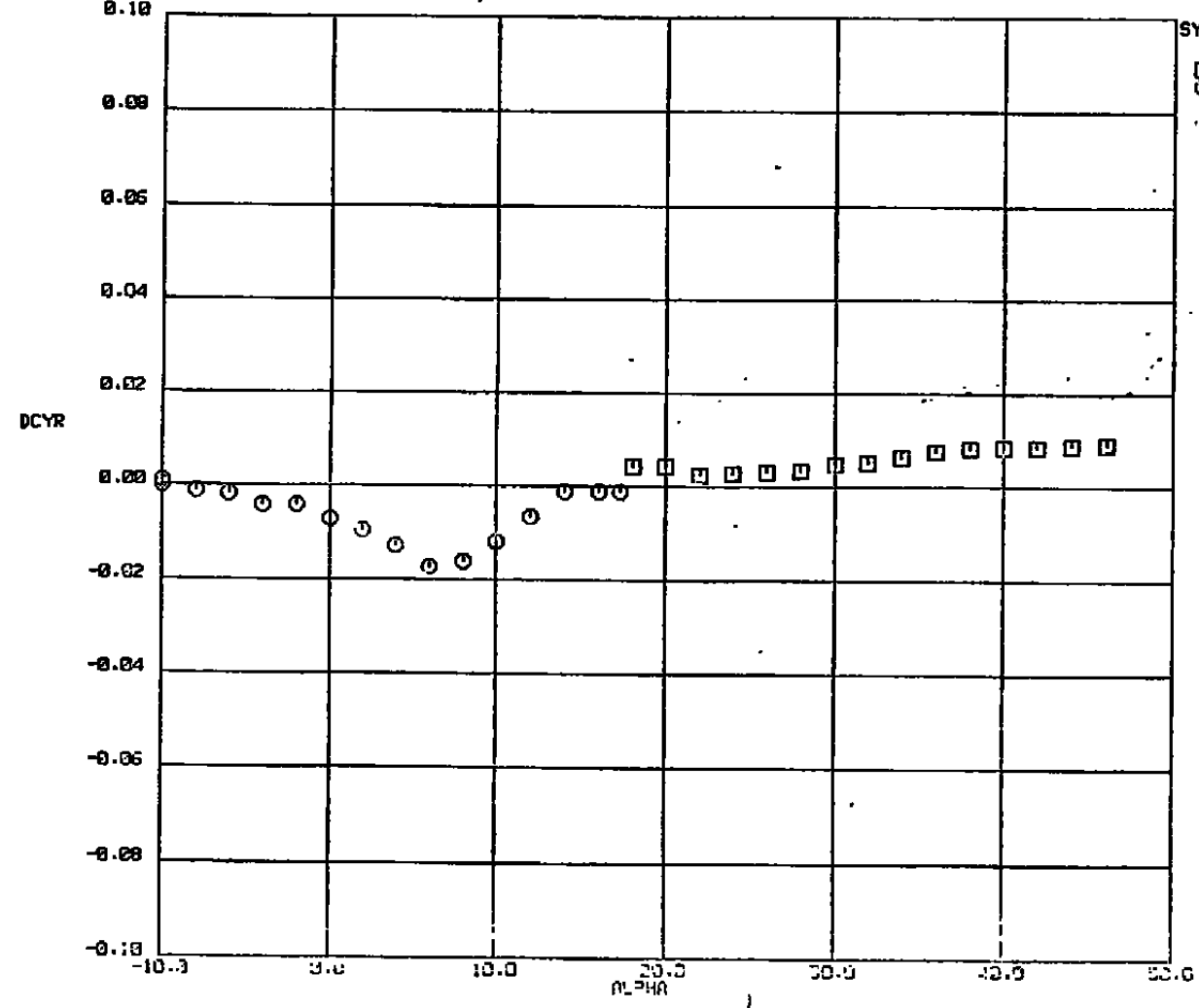

FIL RAM FILE  
A MMRAT.TRA

PAGE 7  
2000

44

Sample 4. Continued

SHUTTLE 0A352

HEADING  
FIL RUN  
A 171

RUN  
171.0

M  
0.0000

CONFIG  
9

MR  
0.2050E-01

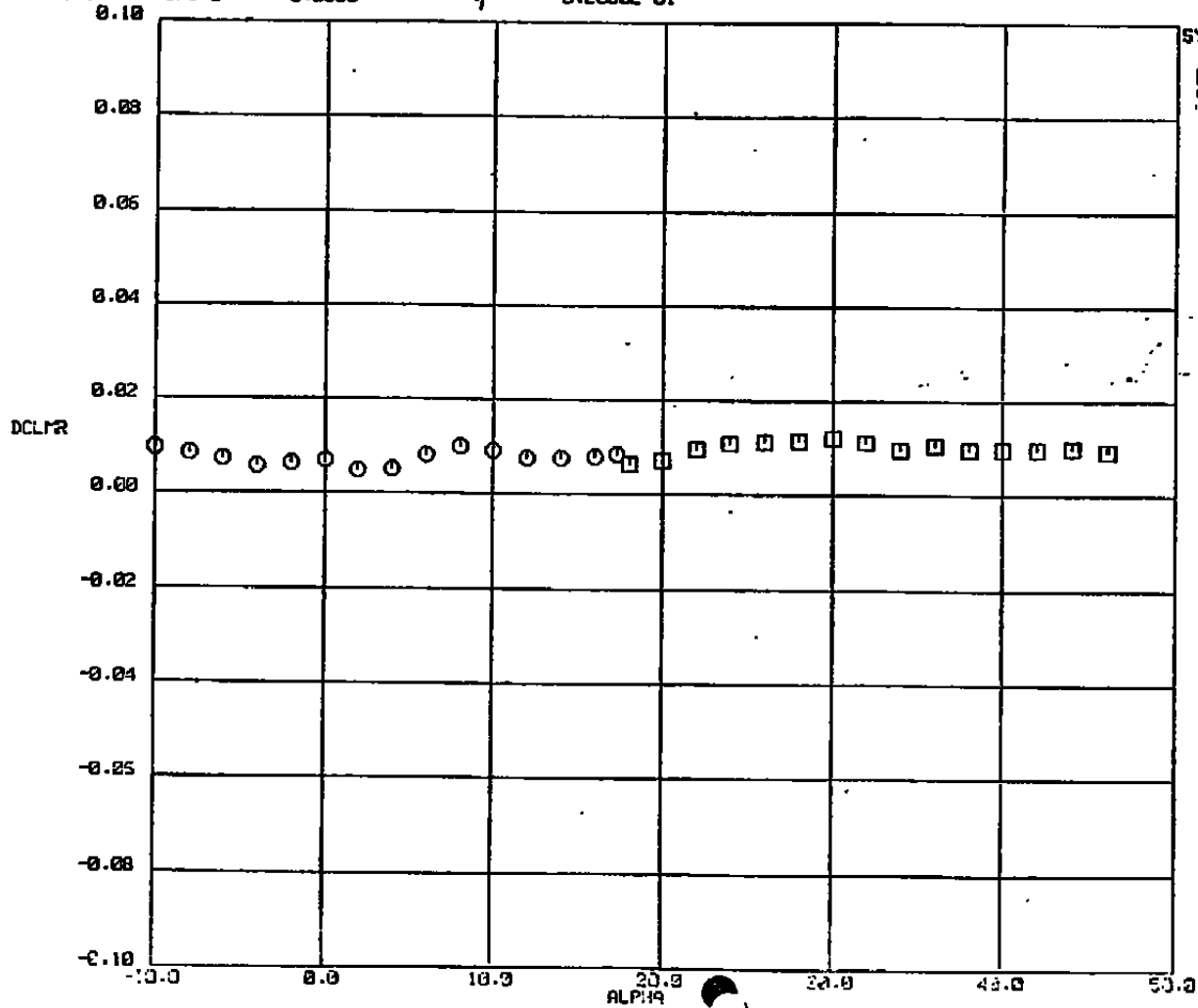

SYMB FIL RUN MR  
(X10<sup>-2</sup>)  
A 171 2.050  
A 50 2.100

FIL RAM FILE  
A MMRAT.TRA

PAGE 2  
03:58

45

Sample 4. Continued

SHUTTLE 0A352

HEADING  
FIL RUN  
A 171

RUN  
171.0

M  
0.0000

CONFIG  
9

MR  
0.2060E-01

SYMB FIL RUN  
CE A 171  
A 50

MR  
( $\times 10^{-2}$ )  
2.060  
2.108

DCLNR

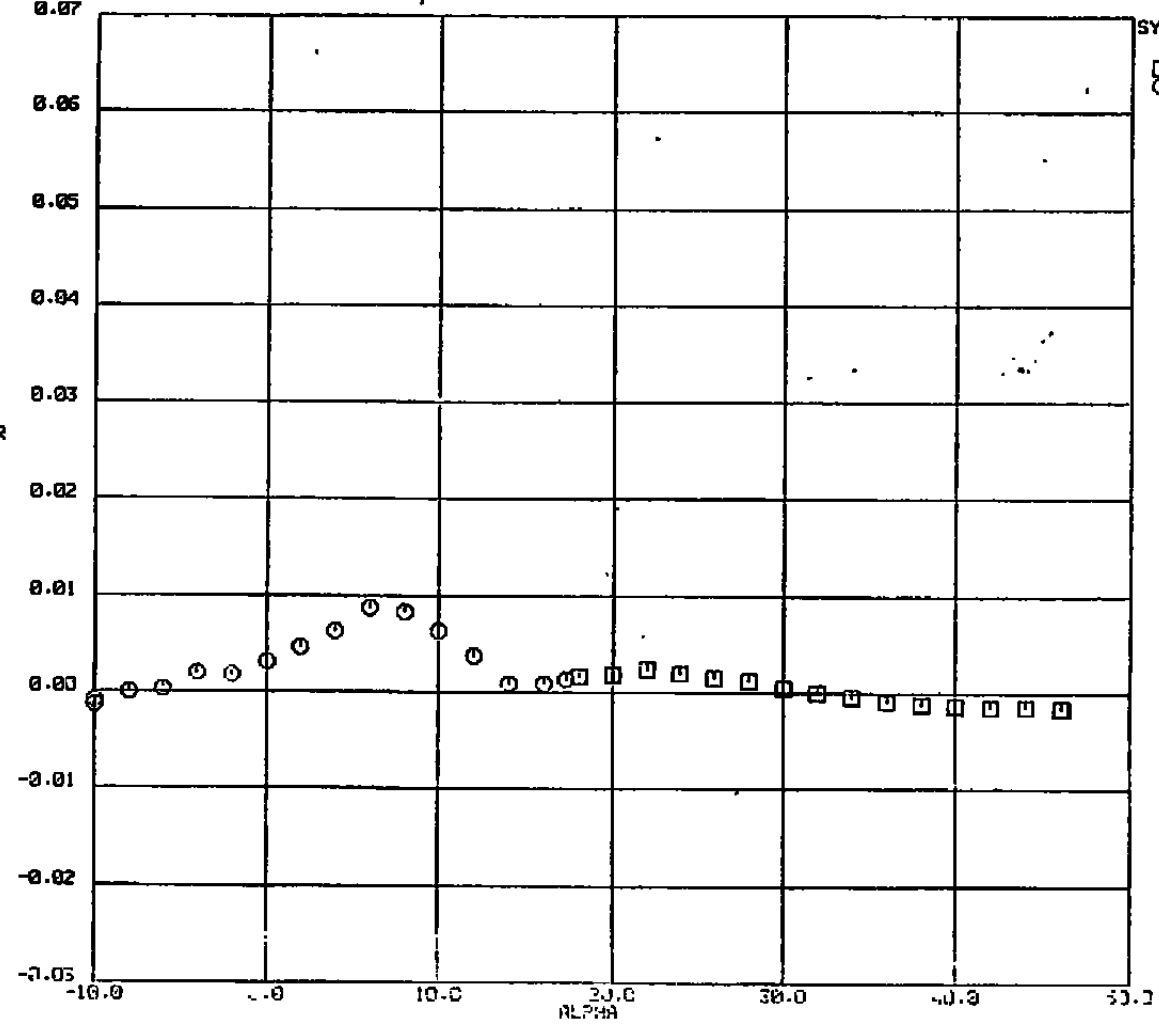

FIL RAM FILE  
A MOMRAT-TRA

PAGE 4  
07:53

46

Sample 4. Continued

SHUTTLE 0A352

HEADING  
FIL RUN  
A 171

RUN  
171.0

H  
0.000

CONFIG  
f

MR  
0.2060E-01

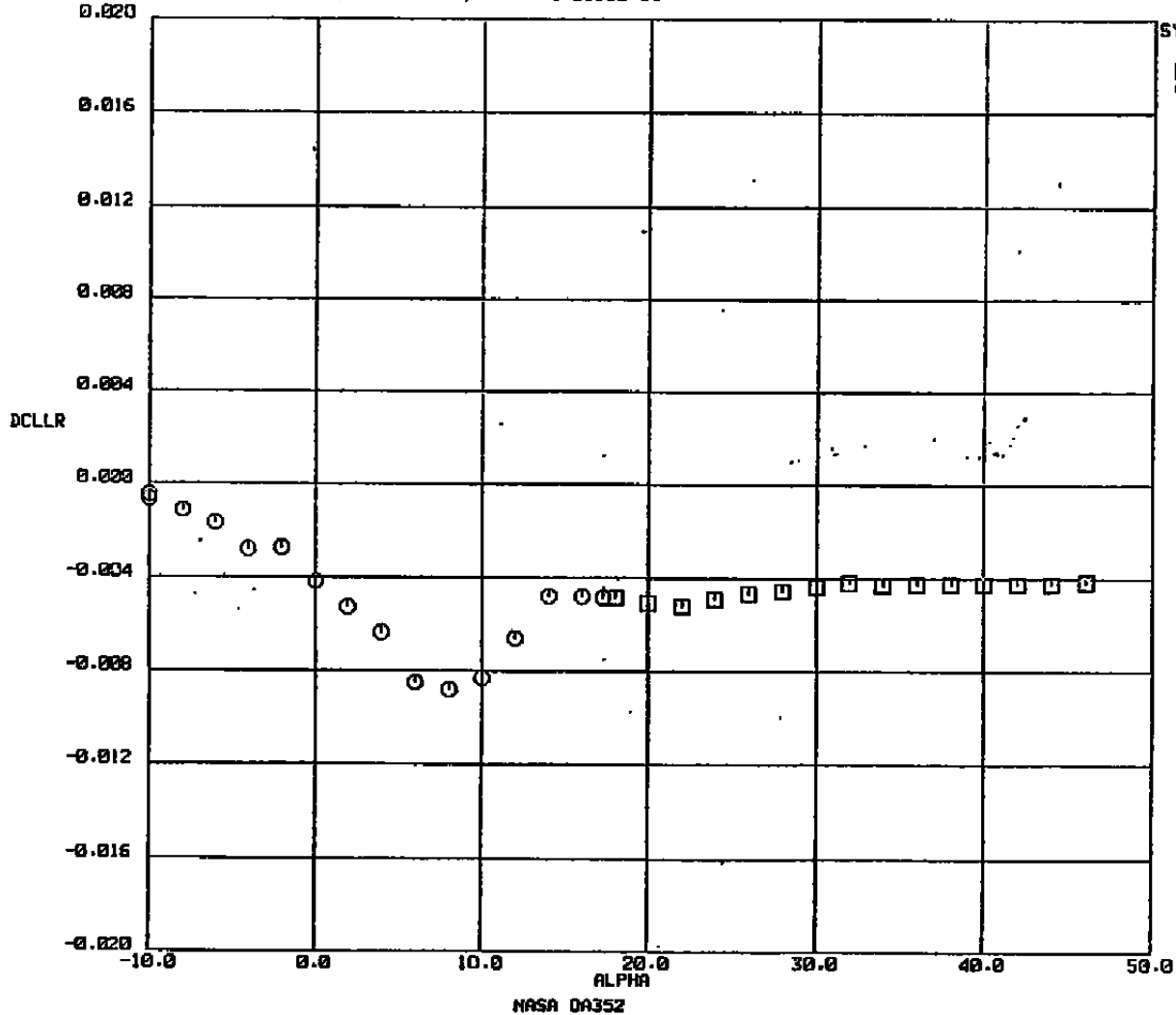

SYMB FIL RUN  
MR  
(X10<sup>-2</sup>)  
2.060  
2.108

FIL RAM FILE  
A NOMRAT.TRA

PAGE 5  
03:58  
06-FEB-87  
011INCMIT-617

47

Sample 4. Concluded